

## Operating Instructions DVD Home Theater Sound System

Model No. **SC-PT350W**



**Before connecting, operating or adjusting this product, please read the instructions completely. Please keep this manual for future reference.**

Your unit may not look exactly the same as illustrated.

**Note**

“EB” on the packaging indicates the United Kingdom.

The player plays DVD-Video marked with labels containing the region number “2” or “ALL”.

Example:



**Wireless system**

Wireless surround speaker connection.

page 9

**USB connection for MP3 players**

page 35



EB

RQTX0059-B



## Dear customer

Thank you for purchasing this product.  
For optimum performance and safety, please read these instructions carefully.

Operations in these instructions are described mainly with the remote control, but you can perform the operations on the main unit if the controls are the same.

System	SC-PT350W
Main unit	SA-PT350
Front speakers	SB-HF350
Center speaker	SB-HC350
Surround speakers	SB-HF350
Subwoofer	SB-HW350
Wireless system	SE-FX65
Digital transmitter	SH-FX65T

### CAUTION!

**THIS PRODUCT UTILIZES A LASER.**  
USE OF CONTROLS OR ADJUSTMENTS OR PERFORMANCE OF PROCEDURES OTHER THAN THOSE SPECIFIED HEREIN MAY RESULT IN HAZARDOUS RADIATION EXPOSURE.  
DO NOT OPEN COVERS AND DO NOT REPAIR YOURSELF. REFER SERVICING TO QUALIFIED PERSONNEL.

### WARNING:

**TO REDUCE THE RISK OF FIRE, ELECTRIC SHOCK OR PRODUCT DAMAGE,**

- DO NOT EXPOSE THIS APPARATUS TO RAIN, MOISTURE, DRIPPING OR SPLASHING AND THAT NO OBJECTS FILLED WITH LIQUIDS, SUCH AS VASES, SHALL BE PLACED ON THE APPARATUS.
- USE ONLY THE RECOMMENDED ACCESSORIES.
- DO NOT REMOVE THE COVER (OR BACK); THERE ARE NO USER SERVICEABLE PARTS INSIDE. REFER SERVICING TO QUALIFIED SERVICE PERSONNEL.

### CAUTION!

- DO NOT INSTALL OR PLACE THIS UNIT IN A BOOKCASE, BUILT-IN CABINET OR IN ANOTHER CONFINED SPACE. ENSURE THE UNIT IS WELL VENTILATED. TO PREVENT RISK OF ELECTRIC SHOCK OR FIRE HAZARD DUE TO OVERHEATING, ENSURE THAT CURTAINS AND ANY OTHER MATERIALS DO NOT OBSTRUCT THE VENTILATION VENTS.
- DO NOT OBSTRUCT THE UNIT'S VENTILATION OPENINGS WITH NEWSPAPERS, TABLECLOTHS, CURTAINS, AND SIMILAR ITEMS.
- DO NOT PLACE SOURCES OF NAKED FLAMES, SUCH AS LIGHTED CANDLES, ON THE UNIT.
- DISPOSE OF BATTERIES IN AN ENVIRONMENTALLY FRIENDLY MANNER.

The socket outlet shall be installed near the equipment and easily accessible.  
The mains plug of the power supply cord shall remain readily operable. To completely disconnect this apparatus from the AC Mains, disconnect the power supply cord plug from AC receptacle.

This product may receive radio interference caused by mobile telephones during use. If such interference is apparent, please increase separation between the product and the mobile telephone.

THIS UNIT IS INTENDED FOR USE IN MODERATE CLIMATES.

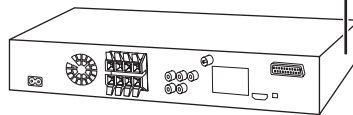

(Side of product)

<b>CAUTION</b>	- LASER RADIATION WHEN OPEN. DO NOT STARE INTO BEAM.	FDA 21 CFR / Class II
<b>CAUTION</b>	- CLASS 1M VISIBLE AND INVISIBLE LASER RADIATION WHEN OPEN. DO NOT VIEW DIRECTLY WITH OPTICAL INSTRUMENTS. (E3000251-1+A2) Class 1M	
<b>WARNING</b>	- CLASS 1M SYNSIG OG OSYNLIG LASERSTRÅLING NÅR DENNEN DEL ER ÖPPNAD. BETRÄTTA EJ STRÅLNINGEN GENOM OPTISKE INSTRUMENTER.	
<b>FORSIGTIG</b>	- SYNSIG OG USYNLIG LASERSTRÅLING KLASSE 1M. NÅR LÅGET ER ÅBENT, UNDGA AT SE UDGE PÅ MED OPTISKE INSTRUMENTER.	
<b>VARO!</b>	- AVATTAESSA OLET ALTIMA LUKKAN MÄRKÄVÄÄ JA NÄKYMÄTÖNTÄ LASERSÄTELYÄ, ÄLÄ KATSO OPTISELLÄ LAITTEELLA SUORAAN SÄTEESEEN.	
<b>VORSICHT</b>	- SICHTBARE UND UNSICHTBARE LASERSTRÄHLUNG KLASSE 1M. WENN ABDECKUNG GEÖFFNET, NICHT DIREKT MIT OPTISCHEN INSTRUMENTEN BETRACHTEN.	
<b>ATTENTION</b>	- RAYONNEMENT LASER VISIBLE ET INVISIBLE. CLASSE 1M. EN CAS D'OUVERTURE, NE PAS REGARDER DIRECTEMENT À LAIDE D'INSTRUMENTS D'OPTIQUE.	
注意	- ここを開くと可視及び不可視レーザー光が出ます。 ビームを見たり、覗いたりしないでください。	
注意	- 打开時可见及不可见激光辐射。避免肉眼照射。	GB7243.1-1993(GB 209) 类 RQLXS0075

Inside of product

## Caution for AC Mains Lead

For your safety, please read the following text carefully.

This appliance is supplied with a moulded three pin mains plug for your safety and convenience.

A 5-ampere fuse is fitted in this plug.

Should the fuse need to be replaced please ensure that the replacement fuse has a rating of 5-ampere and that it is approved by ASTA or BSI to BS1362.

Check for the ASTA mark  or the BSI mark  on the body of the fuse.

If the plug contains a removable fuse cover you must ensure that it is refitted when the fuse is replaced.

If you lose the fuse cover the plug must not be used until a replacement cover is obtained.

A replacement fuse cover can be purchased from your local dealer.

### CAUTION!

IF THE FITTED MOULDED PLUG IS UNSUITABLE FOR THE SOCKET OUTLET IN YOUR HOME THEN THE FUSE SHOULD BE REMOVED AND THE PLUG CUT OFF AND DISPOSED OF SAFELY. THERE IS A DANGER OF SEVERE ELECTRICAL SHOCK IF THE CUT OFF PLUG IS INSERTED INTO ANY 13-AMPERE SOCKET.

If a new plug is to be fitted please observe the wiring code as stated below.

If in any doubt please consult a qualified electrician.

### IMPORTANT

The wires in this mains lead are coloured in accordance with the following code:

Blue: Neutral, Brown: Live.

As these colours may not correspond with the coloured markings identifying the terminals in your plug, proceed as follows:

The wire which is coloured Blue must be connected to the terminal which is marked with the letter N or coloured Black or Blue.

The wire which is coloured Brown must be connected to the terminal which is marked with the letter L or coloured Brown or Red.

**WARNING: DO NOT CONNECT EITHER WIRE TO THE EARTH TERMINAL WHICH IS MARKED WITH THE LETTER E, BY THE EARTH SYMBOL  OR COLOURED GREEN OR GREEN/YELLOW.**

**THIS PLUG IS NOT WATERPROOF—KEEP DRY.**

### Before use

Remove the connector cover.

### How to replace the fuse

The location of the fuse differ according to the type of AC mains plug (figures A and B). Confirm the AC mains plug fitted and follow the instructions below. Illustrations may differ from actual AC mains plug.

1. Open the fuse cover with a screwdriver.

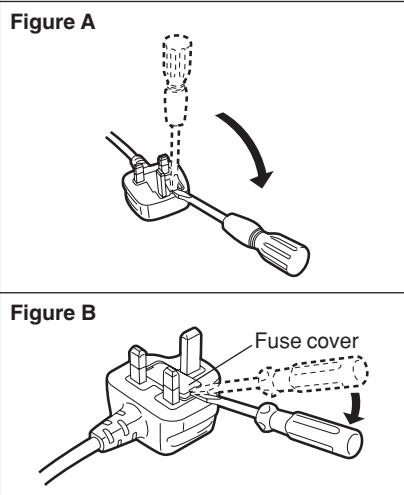

2. Replace the fuse and close or attach the fuse cover.

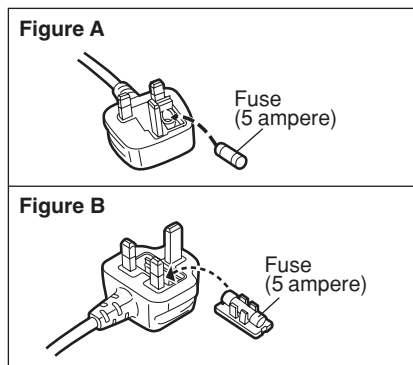



## -If you see this symbol-

### Information on Disposal for Users of Waste Electrical & Electronic Equipment (private households)



This symbol on the products and/or accompanying documents means that used electrical and electronic products should not be mixed with general household waste.

For proper treatment, recovery and recycling, please take these products to designated collection points, where they will be accepted on a free of charge basis. Alternatively, in some countries you may be able to return your products to your local retailer upon the purchase of an equivalent new product.

Disposing of this product correctly will help to save valuable resources and prevent any potential negative effects on human health and the environment which could otherwise arise from inappropriate waste handling. Please contact your local authority for further details of your nearest designated collection point. Penalties may be applicable for incorrect disposal of this waste, in accordance with national legislation.

### For business users in the European Union

If you wish to discard electrical and electronic equipment, please contact your dealer or supplier for further information.

### Information on Disposal in other Countries outside the European Union

This symbol is only valid in the European Union. If you wish to discard this product, please contact your local authorities or dealer and ask for the correct method of disposal.

### For Wireless system

Product Identification Marking is located on the bottom of unit.

**DIGITAL TRANSMITTER SH-FX65T**  
**WIRELESS SYSTEM SE-FX65**  
**CE0506@**

OPERATING AT 2400MHz TO 2483.5MHz

### Declaration of Conformity (DoC)

Hereby, Panasonic AVC Networks Singapore Pte. Ltd. (PAVCSG) declares that this product is in compliance with the essential requirements and other relevant provisions of Directive 1999/5/EC. Customers can download a copy of the original DoC to our R&TTE products from our DoC server: <http://www.doc.panasonic.de>

Contact in the EU: Panasonic Services Europe, a Division of Panasonic Marketing Europe GmbH, Panasonic Testing Centre, Winsbergring 15, 22525 Hamburg, F. R. Germany

This product is intended to be used in the following countries:  
 GB (United Kingdom), IS (Iceland), IE (Ireland).

## Safety precautions

### Placement



Set the unit up on an even surface away from direct sunlight, high temperatures, high humidity, and excessive vibration. These conditions can damage the cabinet and other components, thereby shortening the unit's service life.

Do not place heavy items on the unit.

### Voltage



Do not use high voltage power sources. This can overload the unit and cause a fire.

Do not use a DC power source. Check the source carefully when setting the unit up on a ship or other places where DC is used.

### AC mains lead protection

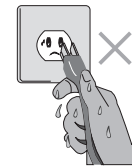

Ensure the AC mains lead is connected correctly and not damaged. Poor connection and lead damage can cause fire or electric shock. Do not pull, bend, or place heavy items on the lead.

Grasp the plug firmly when unplugging the lead. Pulling the AC mains lead can cause electric shock.

Do not handle the plug with wet hands. This can cause electric shock.

### Foreign matter

Do not let metal objects fall inside the unit. This can cause electric shock or malfunction.

Do not let liquids get into the unit. This can cause electric shock or malfunction. If this occurs,



immediately disconnect the unit from the power supply and contact your dealer.

Do not spray insecticides onto or into the unit. They contain flammable gases which can ignite if sprayed into the unit.

### Service

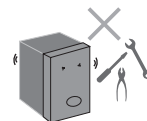

Do not attempt to repair this unit by yourself. If sound is interrupted, indicators fail to light, smoke appears, or any other problem that is not covered in these instructions occurs, disconnect the AC mains lead and contact your dealer or an authorized service center. Electric shock or damage to the unit can occur if the unit is repaired, disassembled or reconstructed by unqualified persons.

Extend operating life by disconnecting the unit from the power source if it is not to be used for a long time.

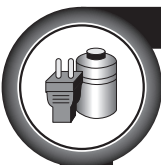

**GETTING STARTED**

**Caution for AC Mains Lead** ..... 3

**Safety precautions** ..... 4

**Accessories** ..... 6

**Preparing the remote control** ..... 6

**Placement of speakers** ..... 7

    Other speaker setup options ..... 8

**Wireless system connection** ..... 9

    Connect the surround speaker cables to the wireless system ..... 9

    Connecting the wireless system to the power supply / Connecting the digital transmitter ..... 9

**Simple setup** ..... 10

    Making the connections ..... 10

**Performing QUICK SETUP** ..... 12

**Disc information** ..... 13

    Discs that can be played ..... 13

**Overview of controls** ..... 14

    Main unit ..... 14

    Remote control ..... 15



**DISC OPERATIONS**

**Disc — Basic play** ..... 16

    Using the main unit / Using the remote control ..... 16

**Advanced play** ..... 18

    Displaying current playback condition / Program and Random play ..... 18

**Playing data discs using navigation menus** ..... 19

    Playing data discs ..... 19

    Playing HighMAT™ discs / Playing RAM and DVD-R/-RW (DVD-VR) discs ..... 20

    Playing the selected track in the CD Text disc ..... 20

**Using on-screen menus** ..... 21

    Functions Menu ..... 21

    Other Settings ..... 22

    Confirming HDMI information ..... 24

**Changing the player settings** ..... 25

    Player settings ..... 25

    Changing the delay time of the speakers ..... 28

    Tips for making data discs ..... 29



**OTHER OPERATIONS**

**Using the radio** ..... 30

    Manual tuning / Selecting the preset channels / Automatic presetting / RDS broadcasting... 30

**Using sound effects** ..... 31

    Enhancing the sound from the center speaker: Center Focus ..... 31

    Adjusting the amount of bass: Subwoofer level ..... 31

    Enhancing the surround sound effect: Surround Enhancer ..... 31

    Changing the sound quality: Equalizer Mode (EQ) ..... 31

    Enhancing the stereo sound: Super Surround ..... 31

    Enhancing the stereo sound: Dolby Pro Logic II ..... 32

    Adjusting the volume of each speaker: Speaker level adjustments ..... 32

**Operating other equipment** ..... 33

    Optional antenna connection / Optional connection for set top box ..... 33

    Connecting with your HDMI-compatible television and set top box ..... 34

    Optional audio connection for video cassette recorder or television ..... 34

    Optional Music Port connection and operation / Optional USB connection and operation .... 35

    Using the VIERA Link “HDMI Control™” ..... 36

    Operating the television ..... 38

    Operating the cable TV box, digital broadcasting or satellite receiver ..... 38

    Changing the main unit and remote control ..... 39

**Language code list** ..... 39



**REFERENCE**

**Troubleshooting guide** ..... 40

**Maintenance** ..... 44

**Glossary** ..... 45

**Specifications** ..... 46



## Accessories

Please check and identify the supplied accessories.

**1 Remote control**  
(N2QAYB000093)



**1 FM indoor antenna**  
(RSA0007-L)

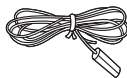

**2 AC mains leads**  
(K2CT3CA00004)



**2 Remote control batteries**



**1 Antenna plug adaptor**  
(K1YZ02000013)

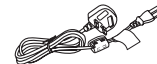

**1 Sheet of speaker cable stickers**



ENGLISH

GETTING STARTED



## Preparing the remote control

**1** Insert so the poles (+ and -) match those in the remote control.

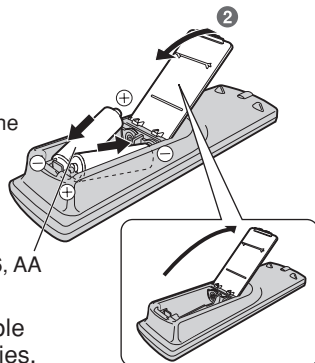

R6/LR6, AA

- Do not use rechargeable type batteries.

### Do not:

- mix old and new batteries.
- use different types of batteries at the same time.
- heat or expose batteries to flame.
- take apart or short circuit the batteries.
- attempt to recharge alkaline or manganese batteries.
- use batteries if the covering has been peeled off.

Mishandling of batteries can cause electrolyte leakage which can severely damage the remote control.

Remove the batteries if the remote control is not going to be used for a long period of time. Store in a cool, dark place.

### Use

Aim at the remote control signal sensor (→ page 14), avoiding obstacles, at a maximum range of 7 m directly in front of the unit.

## Placement of speakers

### Setup example

Place the front, center, and surround speakers at approximately the same distance from the seating position. The angles in the diagram are approximate.

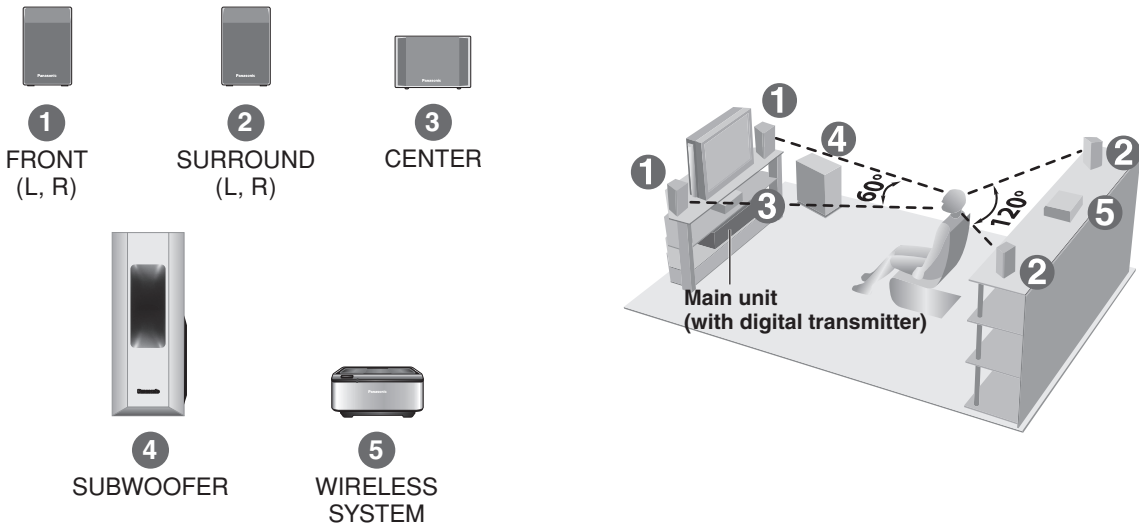

### ■ Avoiding interference

To avoid interference, maintain the following distances between the wireless system and other electronic devices that use the same radio frequency (2.4 GHz band).

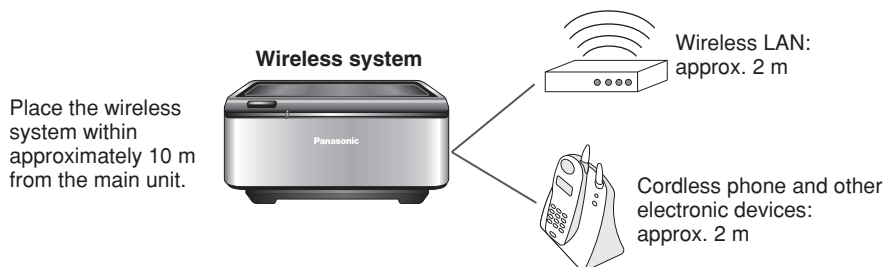

The wireless system will automatically seek a clear channel if any of these other devices interfere with its communication.

When this happens, the wireless link indicator ("W1") flashes on the main unit, and there is a brief interruption in audio coming from the surround speakers.

This is the normal operation of the product working to assure the best possible performance of your home theater system.

If the interference persists, try moving the other devices to another location outside the range of the wireless system or move the wireless system nearer to the main unit.





## Placement of speakers (continued)

ENGLISH

GETTING STARTED



### • Use only supplied speakers

- Using other speakers can damage the unit, and sound quality will be negatively affected.
- Place speakers on flat secure bases. Take proper precautions to prevent the speakers from falling if you cannot set them up on an even surface.
- Placing speakers too close to floors, walls, and corners can result in excessive bass. Cover walls and windows with thick curtains.

### Main unit

- Keep your speakers at least 10 mm away from the system for proper ventilation.
- To allow for proper ventilation and to maintain good airflow around the main unit, position it with at least 5 cm of space on all sides.
- Do not block the ventilation holes of the main unit.

### CAUTION!

- Refrain from holding the speaker's net.



### Center speaker

- Vibration caused by the center speaker can disrupt the picture if it is placed directly on the television. Put the center speaker on a rack or shelf.
- To prevent the speakers from falling, do not place directly on top of the television.

### Subwoofer

- Place to the right or left of the television, on the floor or a sturdy shelf so that it will not cause vibration. Leave a space of 30 cm from the television.

### Note

- You can damage your speakers and shorten their useful life if you play sound at high levels over extended periods.
- Reduce the volume in the following cases to avoid damage:
  - When playing distorted sound.
  - When the speakers are reverberating due to a record player, noise from FM broadcasts, or continuous signals from an oscillator, test disc, or electronic instrument.
  - When adjusting the sound quality.
  - When turning the unit on or off.

### If irregular coloring occurs on your television

The front and center speakers are designed to be used close to a television, but the picture may be affected with some televisions and setup combinations.

### If this occurs, turn the television off for about 30 minutes.

The television's demagnetizing function should correct the problem. If it persists, move the speakers further away from the television.

### Caution

- The main unit and supplied speakers are to be used only as indicated in this setup. Failure to do so may lead to damage to the amplifier and/or the speakers, and may result in the risk of fire. Consult a qualified service person if damage has occurred or if you experience a sudden change in performance.
- Do not attempt to attach these speakers to walls using methods other than those described in this manual.

## Other speaker setup options

### ■ Attaching to a wall

You can attach the front, surround and center speakers to the wall.

- The wall or pillar on which the speakers are to be attached should be capable of supporting 10 kg per screw. Consult a qualified building contractor when attaching the speakers to a wall. Improper attachment may result in damage to the wall and speakers.

#### 1 Drive a screw (not included) into a wall.

#### 2 Fit the speaker securely onto the screw(s) with the hole(s).

Front and surround speakers

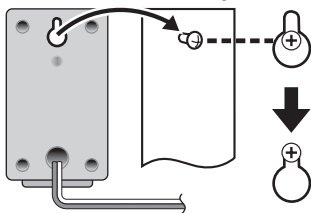

Center speaker

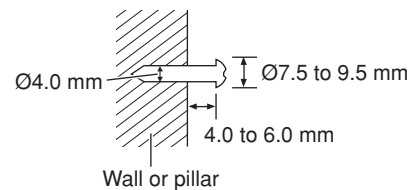
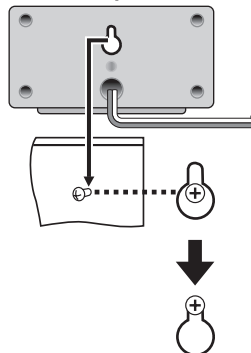

RQTX0059

8



## Wireless system connection

### Connect the surround speaker cables to the wireless system

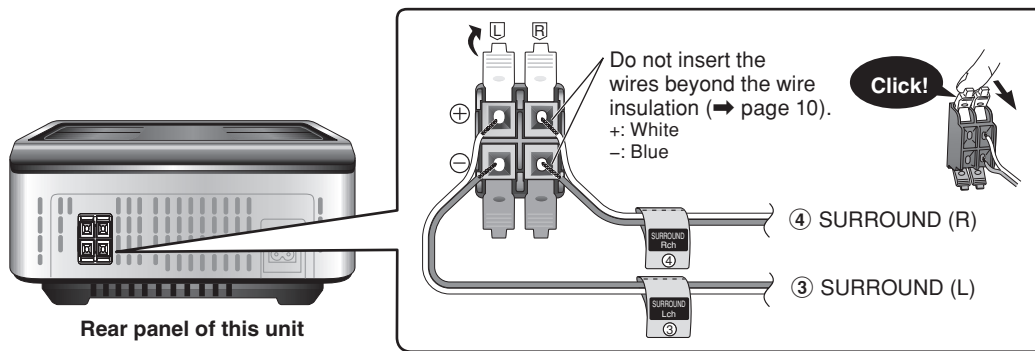

### Connecting the wireless system to the power supply

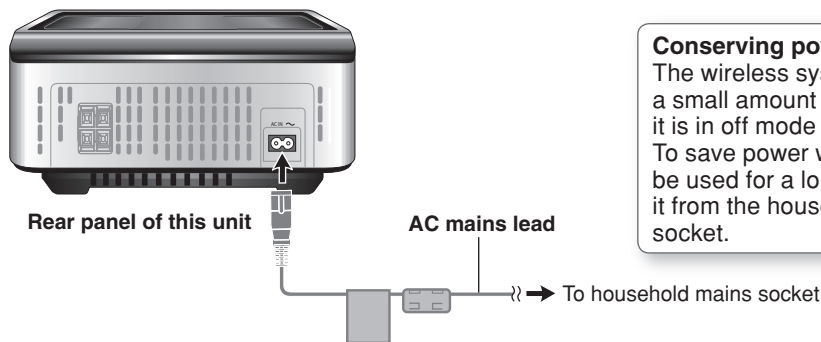

#### Conserving power

The wireless system consume a small amount of power when it is in off mode (approx. 0.3 W). To save power when it is not to be used for a long time, unplug it from the household mains socket.

### Connecting the digital transmitter

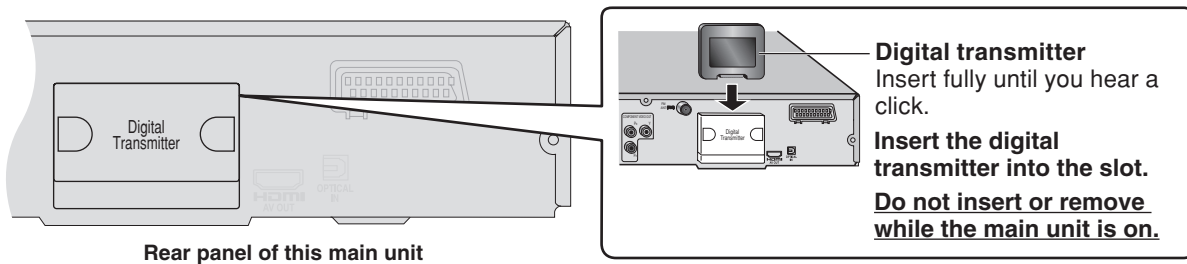

The illustration shows the wireless system for SH-FX65.

#### AUTO OPERATION ON/OFF indicator

This indicator lights red when the unit is turned on and lights green when the wireless link is activated. When the wireless link is inactive for a long time, it turns red.



#### Unit on/off button

[ ] [ ] [ ]

Use this button to turn the unit on and off.

■ I: The unit is on.

■ ⏻: The unit is off.



# Simple setup

## Making the connections

Connect the AC mains lead only after all other connections have been made.  
 • Ensure that you have the complete accessories before making the connections.

### Conserving power

The main unit consumes a small amount of power, even when it is standby mode (approx. 0.8 W). To save power when the unit is not to be used for a long time, unplug it from the household mains socket. You will need to reset some memory items after plugging in the unit.

### Connect to the power supply.

**BE SURE TO READ THE NOTE ON AC MAINS LEAD ON PAGE 3 BEFORE CONNECTION.**

#### Note

The included AC mains lead is for use with this unit only. Do not use it with other equipment.

### Connect to the antenna.

#### FM indoor antenna

Tape the antenna where reception is the best.

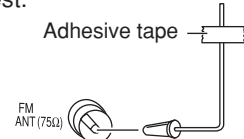

ENGLISH

GETTING STARTED

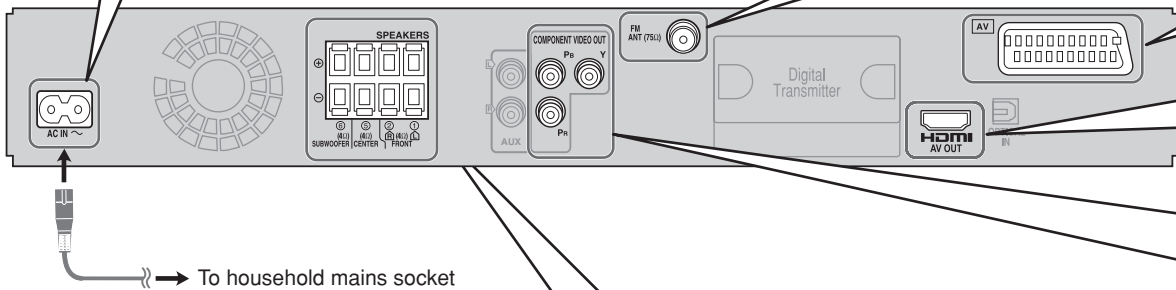

### Connect to the speakers.

Attach the speaker-cable stickers to make connection easier.

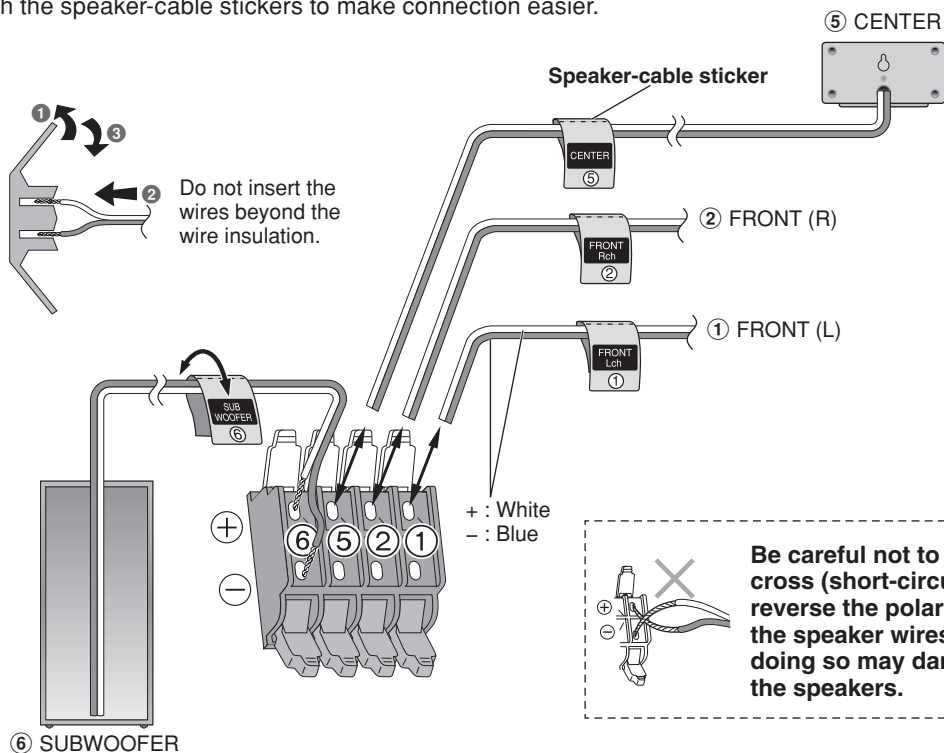

RQTX0059



## Connect to the various television terminals.

- Do not connect the unit through a video cassette recorder.
- Due to copy guard protection, the picture may not be displayed correctly.
- Turn the television off before connecting, and refer to the television's operating instructions.

### ■ Television with SCART terminal

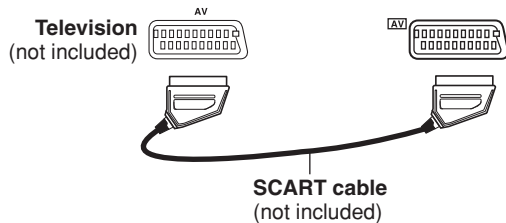

#### Using the SCART (AV) terminal

You can change the video signal output from the SCART (AV) terminal from "RGB" to either "S-Video" or "Video" to suit the type of television you are using. Select "S-Video/YPbPr" or "Video/YPbPr" from QUICK SETUP (⇒ page 12). Set "Video Mode" to "Off" (⇒ page 27, "HDMI" tab). This connection will also enable you to play audio from your television through your home theater system. Refer to "Operating other equipment" (⇒ page 33 and 34).

### ■ Television with an HDMI terminal

HDMI-compatible television (not included)

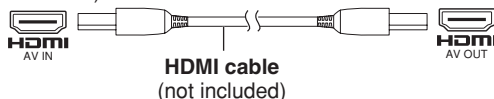

Use the HDMI connection to enjoy higher quality audio and video with a single cable.

- Set "Video Mode" to "On" and "Audio Output" to "On" (⇒ page 27, "HDMI" tab).
- Set "Video Output Mode" (⇒ page 23, Picture Menu).

#### VIERA Link ("HDAVI Control")

If your Panasonic television is a VIERA Link compatible television, you can operate your television synchronising with home theater operations or vice versa (⇒ page 36).

#### Note

- Make the extra audio connection (⇒ page 34) when you use "HDAVI Control" function.
- It is recommended that you use Panasonic's HDMI cable. [Recommended part number: RP-CDHG15 (1.5 m), RP-CDHG30 (3.0 m), RP-CDHG50 (5.0 m), etc.]
- Non-HDMI-compliant cables cannot be utilised.

### ■ Television with COMPONENT VIDEO IN terminals

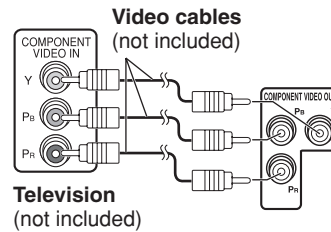

#### Using the COMPONENT VIDEO OUT terminals

These terminals can be used for either interlaced or progressive output. Connection using these terminals outputs the color difference signals (P<sub>B</sub>/P<sub>R</sub>) and luminance signal (Y) separately in order to achieve high fidelity in reproducing colors.

- The description of the component video input terminals depends on the television or monitor (example: Y/P<sub>B</sub>/P<sub>R</sub>, Y/B-Y/R-Y, Y/C<sub>B</sub>/C<sub>R</sub>).
- Connect to terminals of the same color.

#### To enjoy progressive video

- Connect to a progressive output compatible television.
  - ① Set "Video Mode" to "Off" (⇒ page 27, "HDMI" tab).
  - ② Set "Video Output Mode" to "480p" or "576p", and then follow the instructions on the menu screen (⇒ page 23, Picture Menu).

- Panasonic televisions with 625 (576)/50i-50p, 525 (480)/60i-60p input terminals are progressive compatible. Consult the manufacturer if you have another brand of television.

# Performing QUICK SETUP

The QUICK SETUP screen assists you to make necessary settings.

To display the picture from this main unit, switch on the television and change the television's input mode which is connected to this main unit (example: VIDEO 1, AV 1, etc.).

To change your television's input mode, refer to its operating instructions.

- This remote control is able to perform some basic television operations (➔ page 38).

ENGLISH

GETTING STARTED



**2** Select "DVD/CD".



**1** Switch on the main unit.

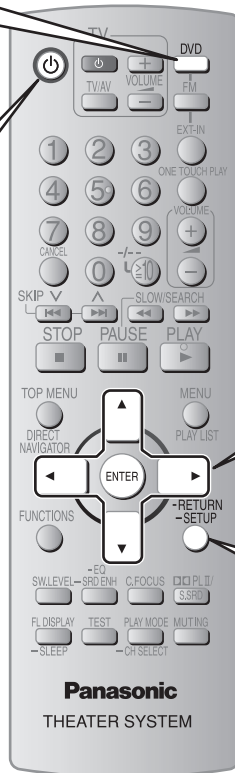

**3** Shows the QUICK SETUP screen



(Press and hold)

**4** Follow the messages and make the setting.

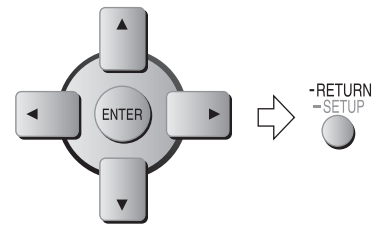

**5** Finish the QUICK SETUP.



**6** Press to exit.



To change these settings later

Select "QUICK SETUP" in "Others" tab (➔ page 27).

## ■ Details of settings

<b>Menu language</b> Choose the language for the on-screen messages.	<ul style="list-style-type: none"> <li>English</li> <li>Español</li> <li>Français</li> <li>Polski</li> <li>Deutsch</li> <li>Svenska</li> <li>Italiano</li> <li>Nederlands</li> </ul>
<b>TV Type</b> Select to suit the type of television.	<ul style="list-style-type: none"> <li>Standard (Direct View TV)</li> <li>CRT Projector</li> <li>Projection TV</li> <li>LCD TV/Projector</li> <li>Plasma TV</li> </ul>
<b>TV Aspect</b> Choose the setting to suit your television and preference.	<ul style="list-style-type: none"> <li>4:3: Regular aspect television</li> <li>16:9: Widescreen television</li> </ul>
<b>Video Out (AV/Component)</b> Choose the video signal format to be output from the SCART (AV) and Component terminal.	<ul style="list-style-type: none"> <li>Video/YPbPr</li> <li>S-Video/YPbPr</li> <li>RGB/No Output</li> </ul>



- Boxed items in the above table are the factory preset.

RQTX0059



## Disc information

### Discs that can be played

#### Commercial discs

Disc	Logo	Indicated in these instructions by	Remarks
DVD-Video		<b>DVD-V</b>	High quality movie and music discs.
Video CD		<b>VCD</b>	Music discs with video. Including SVCD (Conforming to IEC62107).
CD		<b>CD</b>	Music discs

#### Recorded discs (O: Playable, X: Not playable)

Disc	Logo	Recorded on a DVD video recorder, etc.		Recorded on a personal computer, etc.			Finalizing <sup>※6</sup>
		<b>DVD-VR</b> <sup>※2</sup>	<b>DVD-V</b> <sup>※4</sup>	<b>WMA</b>	<b>MP3</b>	<b>JPEG</b>	
DVD-RAM		O	—	X	O	O	Not necessary
DVD-R/RW		O	O	X	O	O	Necessary
DVD-R DL		O <sup>※3</sup>	O	X	X	X	Necessary
+R/+RW	—	X	(O) <sup>※5</sup>	X	X	X	Necessary
+R DL	—	X	(O) <sup>※5</sup>	X	X	X	Necessary
CD-R/RW <sup>※1</sup>	—	—	—	O	O	O	Necessary <sup>※7</sup>

• It may not be possible to play all the above-mentioned discs in some cases due to the type of disc, the condition of the recording, the recording method, or how the files were created (→ page 29, Tips for making data discs).

※1 This unit can play CD-R/RW recorded with CD-DA or Video CD format.

**WMA** **MP3** **JPEG** This unit also plays HighMAT discs.

※2 Discs recorded on DVD video recorders or DVD video cameras, etc. using Version 1.1 of the Video Recording Format (a unified video recording standard).

※3 Discs recorded on DVD video recorders or DVD video cameras using Version 1.2 of the Video Recording Format (a unified video recording standard).

※4 Discs recorded on DVD video recorders or DVD video cameras using DVD-Video Format.

※5 Recorded using a format different from DVD-Video Format, therefore, some functions cannot be used.

※6 A process that allows play on compatible equipment. To play a disc that is displayed as "Necessary" on this unit, the disc must first be finalized on the device it was recorded on.

※7 Closing the session will also work.



## Disc information (continued)



### Note about using a DualDisc

The digital audio content side of a DualDisc does not meet the technical specifications of the Compact Disc Digital Audio (CD-DA) format so playback may not be possible.

### Discs that cannot be played

DVD-RW version 1.0, DVD-Audio, DVD-ROM, CD-ROM, CDV, CD-G, SACD, Photo CD, DVD-RAM that cannot be removed from their cartridge, 2.6-GB and 5.2-GB DVD-RAM, and "Chaoji VCD" available on the market including CVD, DVCD and SVCD that do not conform to IEC62107.

### Video systems

- This unit can play PAL and NTSC, but your television must match the system used on the disc.
- PAL discs cannot be correctly viewed on an NTSC television.
- This unit can convert NTSC signals to PAL 60 for viewing on a PAL television (→ page 26, "NTSC Disc Output" in "Video" tab).

### Disc handling precautions

- Do not attach labels or stickers to discs. This may cause disc warping, rendering it unusable.
- Do not write on the label side with a ball-point pen or other writing instrument.
- Do not use record cleaning sprays, benzene, thinner, static electricity prevention liquids or any other solvent.
- Do not use scratch-proof protectors or covers.
- Do not use the following discs:
  - Discs with exposed adhesive from removed stickers or labels (rented discs, etc).
  - Discs that are badly warped or cracked.
  - Irregularly shaped discs, such as heart shapes.

### To clean discs

- Wipe with a damp cloth and then wipe dry.

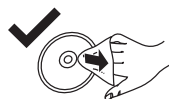

## Overview of controls

### Main unit

#### Standby/on switch [⏻/⏻] (16)

Press to switch the unit from on to standby mode or vice versa. In standby mode, the unit is still consuming a small amount of power.

#### MUSIC PORT jack

Connect an external device (35)

#### ▲ OPEN/CLOSE

Open or close the disc tray (16)

#### USB port

Connect a USB device (35)

#### AC supply indicator [AC IN]

This indicator lights when the unit is connected to the AC mains supply.

Remote control signal sensor

#### SELECTOR (16, 30)

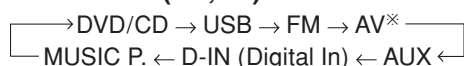

#### ▶/MEMORY

Disc playback (16),

Memorise the receiving radio stations (30)

#### ■ /- TUNE MODE /- FM MODE

Stop playback, Select the tuning mode (30),  
Adjust the FM reception condition (30)

#### VOLUME -, +

Turn the volume up or down (16)



∇ TUNE ▲

Skipping or slow-search play, Select the radio stations (30)

Headphones (not included)

#### Headphone plug type:

- Ø3.5 mm stereo mini plug
- Reduce the volume before connecting.
- Audio is automatically switched to 2-channel stereo.
- To prevent hearing damage, avoid listening for prolonged periods of time.



Remote control



Television operations (38)

Switch the main unit on or off (16)

Change the television's video input mode (38)

Select disc's title numbers and etc., Enter numbers (17)

Select preset radio stations (30)

Show a disc top menu (17) or program list (17)

Show on-screen menu (21)

Show the display on the main unit (17).  
Set the sleep timer  
This function enables you to turn off the unit automatically after the set time  
SLEEP 30 → SLEEP 60 → SLEEP 90  
↑ OFF ← SLEEP 120 ←  
**To cancel the timer**  
Press and hold [-SLEEP] to select "OFF".  
**To confirm the remaining time**  
Press and hold [-SLEEP] again.

Adjust the television volume (38)

Select the source  
**DVD:** DVD/CD (12)  
**FM** (30)  
**EXT-IN:** USB (35), AV\* (38), AUX (34), D-IN (38), MUSIC P. (35)

Start up and play a disc automatically, Control both the home theater system and the television (36)

Adjust the volume of the main unit (32)

Basic operations for play (17)

Show a disc menu or play list (17)

Select or confirm menu items on the television screen (12), Frame-by-frame (17)

Return to previous screen (17), Show the setup menu (12)

To mute the sound  
**To cancel**  
• Press [MUTING] again or adjust the volume.  
• Muting is cancelled when you switch the unit to standby.

\* "AV" only works when the scart cable is connected (⇒ page 11).

# Disc — Basic play

## Using the main unit

**1 Power on.**



**2 Select "DVD/CD".**



**3 Load a disc in the tray.**



- Load double-sided discs so the label for the side you want to play is facing up.
- For DVD-RAM, remove the disc from its cartridge before use.



**4 Adjust the volume and start playback.**

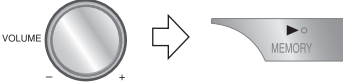

ENGLISH

DISC OPERATIONS



## Using the remote control

**TV** (Power, TV/AV, VOLUME +/-)  
**DVD** (DVD, FM, EXT IN, TOUCH PLAY)  
**Numeric buttons** (1-9, 0, +/-, 10)  
**CANCEL** (7, 8, 9)  
**SKIP** (SKIP, V, ^, >>>)  
**SLOW/SEARCH** (SLOW/SEARCH, <<<, >>>)  
**STOP** (STOP, ■)  
**PAUSE** (PAUSE, ||)  
**PLAY** (PLAY, ►)  
**TOP MENU, DIRECT NAVIGATOR** (TOP MENU, DIRECT NAVIGATOR)  
**MENU, PLAY LIST** (MENU, PLAY LIST)  
**ENTER** (ENTER, ▲, ▼, ◀, ▶)  
**RETURN** (RETURN, -RETURN)  
**FL DISPLAY** (FL DISPLAY, TEST, PLAY MODE, MUTING, -SLEEP, -CH SELECT)  
**Panasonic THEATER SYSTEM**

RQTX0059



### Stop

**STOP** The position is memorised while "RESUME" is on the display.

- Press [▶, PLAY] to resume.
- Press [■, STOP] again to clear the position.

### Pause

**PAUSE** • Press [▶, PLAY] to resume playback.

### Search (during play)

**SLOW/SEARCH**

- Play speed increases up to 5 steps.
- Press [▶, PLAY] to resume normal playback.

### Slow-motion play (during pause)

**SLOW/SEARCH**

- Play speed increases up to 5 steps.
- [VCD] Slow motion play is for forward direction only.
- Press [▶, PLAY] to resume normal playback.

### Main unit display

**FL DISPLAY** **DVD-V** **DVD-VR** **WMA** **MP3**  
 Time display ↔ Information display

**JPEG**

When Slideshow (⇒ page 22) is on:  
 SLIDE ↔ Information display

When Slideshow (⇒ page 22) is off:  
 PLAY ↔ Information display

### Skip

**SKIP**

**WMA** **MP3** **JPEG**

**[▲, ▼]: Group skip**  
**[◀, ▶]: Content skip**

- This feature does not work during program and random play (⇒ page 18).

### On-screen item select

### Enter numbers

**1** **2** **3** **DVD-V** (while stopped)  
**DVD-VR** **VCD** **CD**

Example: To select 12,  
**1**, **2**

**VCD** with Playback control (PBC)  
 Press [■, STOP] and then press the numeric buttons to cancel the PBC functions.

**Note**

- The numeric buttons that can function depend on the number of tracks on the VCD.

**WMA** **MP3** **JPEG**  
 Example: To select 123,  
**1**, **2**, **3**

### Cancel the numbers

**ENTER**

### Disc menus

**TOP MENU** **DVD-V**  
 Shows a disc top menu.

**DIRECT NAVIGATOR** **DVD-VR**  
 Shows the program (⇒ page 20).

**MENU** **DVD-V**  
 Shows a disc menu.

**PLAY LIST** **DVD-VR**  
 Shows the playlist (⇒ page 20).

**-RETURN -SETUP** **VCD** with Playback control (PBC)  
 Shows a disc menu.

### Frame-by-frame (during pause)

**DVD-V** **DVD-VR** **VCD**

- **VCD** Forward direction only.

### Return to previous screen

**-RETURN -SETUP**

**Note**

- **DISC CONTINUES TO ROTATE WHILE MENUS ARE DISPLAYED.**  
 Press [■, STOP] when you finish to preserve the unit's motor and your television screen.
- Total title number may not be displayed properly on +R/+RW.

## Displaying current playback condition

FUNCTIONS → Functions Menu → Basics → Details (→ page 21)  
 Off (No on-screen display) ←

### Basics

Example: **DVD-V**

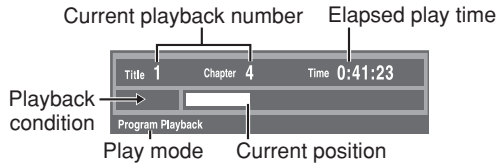

### Details

Example: **DVD-V**

Details-DVD-Video	
Audio information	Audio 1 --- DTS 3/2.1ch
Subtitle information	Subtitle - ---
Angle information	Angle 1/1
Aspect of current title	Source Aspect 4:3
Total play time of current title	Title Total Time 0:54:28

## Program and Random play

**DVD-V** | **VCD** | **CD** | **WMA** | **MP3** | **JPEG**

PLAY MODE (during stop)  
 -CH SELECT

Program → Random → Off (Normal play)

**To exit program or random play mode while stopped.**

PLAY MODE (several times)  
 -CH SELECT

- Selecting "Play as Data Disc" in Other Menu (→ page 24) will be effective if the following functions are not available to play WMA, MP3, or JPEG contents.
- **DVD-V** Some items cannot be played even if you have programmed them.

## Program play (up to 32 items)

**1 Press the numeric buttons to select the item.**  
 ([WMA] [MP3] [JPEG] Press [ENTER] to register the selection.)

- Repeat this step to program other items.

Example: **DVD-V**

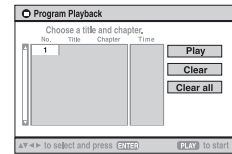

- Repeat this step to program other items.
- To select a 2-digit number

Example: To select 12,



**2 PLAY**



**To select an item using the cursor buttons**

Press [ENTER] and [▲, ▼] to select an item, then press [ENTER] again to confirm.

**To select all the items**

While the "Chapter", "Track" or "Content" field is highlighted, press [▲, ▼] to select "ALL". Then press [ENTER] again to confirm.

Example: **DVD-V**

Chapter	Time
: ALL	

**To change the selected program**

1. Press [▲, ▼] to select the program number.
2. Press the numeric buttons to change each item.  
 ([WMA] [MP3] [JPEG] Press [ENTER] to confirm the selection.)

**To clear the selected program**

1. Press [▲, ▼] to select the program number.
2. Press [CANCEL] (or press [▲, ▼, ◀, ▶] to select "Clear" and press [ENTER]).

**To clear the whole program**

Select "Clear all" with [▲, ▼, ◀, ▶] and press [ENTER].

The whole program is also cleared when the unit is turned off, the disc tray is opened or another source is selected.

## Random play

**1** **DVD-V** | **WMA** | **MP3** | **JPEG**

**Press the numeric buttons to select a group or title.** ([WMA] [MP3] [JPEG] Press [ENTER] to register the selection.)

Example: **DVD-V**

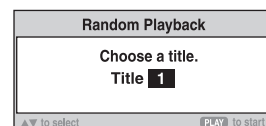

**2 PLAY**



## Playing data discs

WMA MP3 JPEG

Selecting "Play as Data Disc" in Other Menu (→ page 24) will be effective if the following functions are not available to play WMA, MP3, or JPEG contents.

- Playing HighMAT™ discs (→ page 20).

### Playing items in order (Playback Menu)

#### 1 TOP MENU

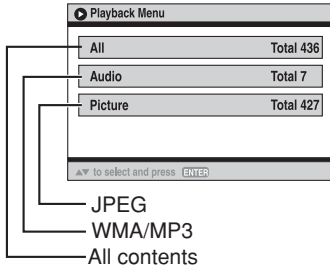

#### 2 To select "All", "Audio" or "Picture".



**To exit the screen**  
Press [TOP MENU].

### Playing from the selected item (Navigation Menu)

#### 1 MENU

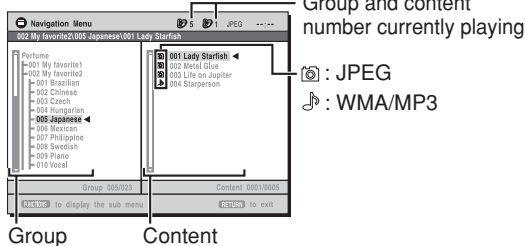

#### 2 To select the group.



#### 3 To play content in the group in order.



**To start play from the selected content.**



**To enjoy listening to WMA/MP3 contents while showing a JPEG image on the screen**

Select a JPEG file first, and then select audio contents.

(The opposite order is not effective.)

**To exit the screen**

Press [MENU].

## Using the submenu

### 1 While the Navigation Menu is displayed

FUNCTIONS



### 2 To select an item.



Items shown differ depending on the type of disc.

Multi	Groups and contents are displayed
List	Contents only
Tree	Groups only
Thumbnail	Thumbnail images [JPEG]
Next group	To go to next group [WMA] [MP3]
Previous group	To go to previous group [WMA] [MP3]
All	WMA/MP3 and JPEG
Audio	WMA/MP3 only
Picture	JPEG only
Help display	To switch between guide messages and the elapsed play time indicator
Find	To search by content or group title (→ see below)

## Searching by a content or a group title

Highlight a group title to search the group, or a content title to search its content.

### 1 While the submenu is displayed (→ see above)

**To select "Find".**



### 2 To select a character.



- Repeat to enter another character.
- Lower case is also searched.
- Press [◀, ▶] to skip between A, E, I, O and U.
- Press [◀] to erase a character.
- Leave the asterisk (\*) when you search for the titles including the character you enter.
- Erase the asterisk (\*) to search for the titles starting with the character you enter. To add the asterisk (\*) again, display the submenu again and select "Find".

### 3 To select "Find".



The search result screen appears.

### 4 To select the content or group.



Playing HighMAT™ discs

WMA MP3 JPEG

1 TOP MENU



2 To select the item.



- Repeat this step if necessary.  
Example:

Menu: Takes you to the next menu which shows play lists or another menu

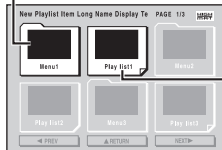

Playlist: Play starts

To change the menu background

Press [FUNCTIONS].

The background changes to the one recorded on the disc.

To exit the screen

Press [■, STOP].

Selecting from the list

1 During play

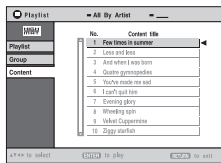

2 To switch among "Playlist", "Group" and "Content" lists.



3 To select an item



To exit the screen

Press [MENU].

Playing RAM and DVD-R/-RW (DVD-VR) discs

DVD-VR

- Titles appear only if the titles are recorded on the disc.
- You cannot edit programs, playlists and disc titles.

Playing the programs

1 TOP MENU



2 To select the program.



- Press [▶] to show the contents of the program and the disc.

3 ENTER

To exit the screen

Press [DIRECT NAVIGATOR].

Playing a playlist

Applicable only when the disc contains a playlist.

1 MENU



2 To select the playlist.



3 ENTER

To exit the screen

Press [PLAY LIST].

Playing the selected track in the CD Text disc

CD

Titles appear with CD Text disc playback.

1 TOP MENU



OR MENU



2 To select the track.



- Press [FUNCTIONS] to show the playback condition and current position.

To exit the screen

Press [TOP MENU] or [MENU].





# Using on-screen menus

### 2 Select the menu.

Example: **DVD-V**

Functions	
Title	1/2
Chapter	3/10
Time	0:24:31
Audio	1 English
Subtitle	3

### 3 Make the settings.

Example: **DVD-V**

Functions	
Title	1/2
Chapter	3/10
Time	0:24:31
Audio	1 English
Subtitle	3

### 1 Display the "Functions" screen.

### 4 Press to exit.

Items shown differ depending on the type of disc as well as the recording format.

## Functions Menu

<p><b>Program Group</b></p> <p><b>Title</b></p> <p><b>Chapter</b></p> <p><b>Track</b></p> <p><b>Playlist</b></p> <p><b>Content</b></p>	<p><b>To start from a specific item</b></p> <p>Example: <b>DVD-VR</b></p> <p>To select program 12</p> <p>Press the numeric buttons:</p> <p>1, 2, [ENTER]</p> <table border="1"> <tr><td>Functions</td><td></td></tr> <tr><td>Program</td><td>2/16</td></tr> <tr><td>Time</td><td>0:34:15</td></tr> <tr><td>Audio</td><td></td></tr> </table>	Functions		Program	2/16	Time	0:34:15	Audio		<p><b>Audio</b></p> <p><b>DVD-V</b> (with multiple soundtracks)</p> <p><b>To select audio soundtrack</b></p> <p><b>DVD-VR</b> <b>VCD</b></p> <p><b>To select "LR", "L", "R" or "L+R"</b></p> <p><b>DVD-V</b> (Karaoke disc)</p> <p><b>To select "On" or "Off" for vocals</b></p> <p><b>To select "Off", "V2", "V1" or "V1+V2" for different vocal selections</b></p> <ul style="list-style-type: none"> <li>Read the disc's instructions for details.</li> </ul> <p><b>Signal type/data</b></p> <p>LPCM/PPCM/Digital/DTS/MP3/MPEG: Signal type kHz (Sampling frequency)/bit/ch (Number of channels)</p> <p>Example: 3 / 2 .1ch</p> <ul style="list-style-type: none"> <li>.1: Low frequency effect (not displayed if there is no signal)</li> <li>0: No surround</li> <li>1: Mono surround</li> <li>2: Stereo surround (left/right)</li> <li>1: Center</li> <li>2: Front left + Front right</li> <li>3: Front left + Front right + Center</li> </ul> <p><b>WMA</b> <b>MP3</b></p> <p><b>To display the current bitrate or sampling frequency</b></p>
Functions										
Program	2/16									
Time	0:34:15									
Audio										
<p><b>Time</b></p>	<p>(Time Slip does not work with +R/+RW discs.)</p> <p><b>To skip incrementally or decrementally (Time slip) during play</b></p> <ol style="list-style-type: none"> <li>Press [ENTER] twice to show the Time Slip indicator.</li> <li>Press [▲, ▼] to select the time and press [ENTER].                     <ul style="list-style-type: none"> <li>To change the steps quickly, press and hold [▲, ▼].</li> </ul> </li> </ol> <p><b>To change the elapsed or remaining time display</b></p>									

ENGLISH

DISC OPERATIONS



RQTX0059

Functions Menu (continued)

<b>Number Select</b>	<b>[VCD]</b> with playback control <b>To select number</b> While the disc menu is displayed Press [ <b>▲</b> , <b>▼</b> ] ⇨ Press [ENTER] • To change the numbers more quickly, press and hold [ <b>▲</b> , <b>▼</b> ].	<b>Marker (VR)</b>	<b>[DVD-VR]</b> <b>To recall a marker recorded on DVD-Video recorders</b> Press [ <b>▲</b> , <b>▼</b> ] ⇨ Press [ENTER]
<b>Thumbnail</b>	<b>[JPEG]</b> <b>To show thumbnail images</b>	<b>Angle</b>	(with multiple angles) <b>To select a video angle</b>
<b>Subtitle</b>	<b>[DVD-V]</b> (with multiple subtitles) <b>[VCD]</b> (SVCD only) <b>To select subtitle language</b> • On +R/+RW, a subtitle number may be shown for subtitles that are not displayed. • <b>[DVD-VR]</b> "On" or "Off" appears only with discs that contain subtitle on/off information (Subtitle on/off information cannot be recorded using Panasonic DVD Recorders).	<b>Rotate Picture</b>	<b>To rotate pictures</b>
		<b>Slideshow</b>	<b>To turn the slideshow on/off</b> <b>On</b> ⇔ <b>Off</b> <b>To change the slideshow timing</b> <b>1 (Fast) to 5 (Slow)</b>
		<b>Other Settings</b>	(⇒ see below)



Other Settings

<b>Play Speed</b>	<b>[DVD-V]</b> <b>[DVD-VR]</b> <b>To change play speed</b> – from "x0.6" to "x1.4" • Press [ <b>▶</b> , PLAY] to resume normal playback. • After you change the speed –Dolby Pro Logic II has no effect. –Audio output switches to 2-channel stereo. –Sampling frequency of 96 kHz is converted to 48 kHz. • This function may not work depending on the disc's recording.	<b>Advanced Disc Review</b>	<b>[DVD-V]</b> (Except +R/+RW) <b>[DVD-VR]</b> (Except still picture part) Allows you to browse the disc contents and start playing from the selected position. You can select either "Intro Mode" or "Interval Mode" in "Advanced Disc Review" in the "Disc" tab (⇒ page 25). Example: <b>[DVD-VR]</b>
			 Press [ <b>▶</b> , PLAY] when you find a title or program of your choice. • This may not work depending on the disc and the play position. • <b>[DVD-VR]</b> This does not work when playing a playlist (⇒ page 20).
<b>■ Play Menu</b>		<b>■ Picture Menu</b>	
<b>Repeat</b>	(Only when the elapsed play time can be displayed.) <b>[DVD-V]</b> : Off → Chapter → Title* <b>[DVD-VR]</b> : Off → Program → All During playlist play: Off → Scene → Playlist <b>[VCD]</b> <b>[CD]</b> : Off → Track → All <b>[WMA]</b> <b>[MP3]</b> : Off → Content → Group* <b>[JPEG]</b> : Off → Group* * "All" is displayed during program or random play.	<b>Picture Mode</b>	<b>Normal</b> <b>Cinema1</b> : Mellows images and enhances detail in dark scenes. <b>Cinema2</b> : Sharpens images and enhances detail in dark scenes. <b>Animation</b> : Suitable for animation. <b>Dynamic</b> : Enhances the contrast for powerful images. <b>User</b> : Press [ENTER] to select "Picture Adjustment" (⇒ page 23).
<b>A-B Repeat</b>	Except <b>[DVD-VR]</b> (Still picture part) <b>[JPEG]</b> <b>To repeat a specified section</b> Press [ENTER] at the starting and ending points. Press [ENTER] again to cancel.		



Other Settings (continued)

■ Audio Menu

<b>Dolby Pro Logic II</b>	(⇒ page 32 , Dolby Pro Logic II)
<b>Dialogue Enhancer</b>	To make the dialogue in movies easier to hear <input type="checkbox"/> <b>DVD-V</b> (Dolby Digital, DTS, MPEG, 3-channel or higher, with the dialogue recorded in the center channel) On ↔ Off

■ Display Menu

<b>Information</b>	<input type="checkbox"/> <b>JPEG</b> : On ↔ Off
<b>Subtitle Position</b>	0 to -60
<b>Subtitle Brightness</b>	Auto, 0 to -7
<b>4:3 Aspect</b>	To select how to show images made for 4:3 aspect screens on a 16:9 aspect television <b>Normal</b> : Laterally stretches images. <b>Auto</b> : Expands 4:3 letterbox images to fill more of the screen. Other images appear in full in the center of the screen. <b>Shrink</b> : Images appear in the center of the screen. <b>Zoom</b> : Expands to 4:3 aspect ratio. If your television has a similar feature, use it instead for a better effect.

**Just Fit Zoom**

**DVD-V**  **DVD-VR**  **VCD**

To select the appropriate screen size to fit your television screen

- |                       |                       |
|-----------------------|-----------------------|
| <b>Auto</b>           | <b>American Vista</b> |
| <b>4:3 Standard</b>   | <b>Cinemascope 1</b>  |
| <b>European Vista</b> | <b>Cinemascope 2</b>  |
| <b>16:9 Standard</b>  |                       |

Example:

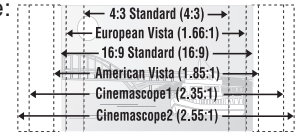

**Manual Zoom**

To zoom in and out manually

- in 0.01-unit steps from "x1.00" to "x1.60"
- in 0.02-unit steps from "x1.60" to "x2.00"
- To change the steps quickly, press and hold [▲, ▼].

**Bit Rate Display**

**DVD-V**  **DVD-VR**  **VCD**

On ↔ Off

**GUI See-through**

To make the on-screen menu transparent  
 Off, On, Auto

**GUI Brightness**

To adjust the on-screen menu brightness  
 -3 to +3

**HDMI Status**

Indicates various information when connected with HDMI AV OUT terminal. (⇒ see below, Confirming HDMI information)

■ Other Menu

<b>Setup</b>	(⇒ page 25)
<b>Play as DVD-VR, Play as HighMAT or Play as Data Disc</b>	To use functions for data discs (⇒ page 19) (To play MP3 or JPEG contents on DVD-RAM, or to play a HighMAT disc without using HighMAT function) Select "Play as Data Disc".

Confirming HDMI information

Example:

<p>■ <b>HDMI Status — HDMI is connected.</b></p> <p>HDMI Information</p> <table border="1"> <tr> <td>Audio Stream</td> <td><u>PCM</u></td> </tr> <tr> <td>Max Channel</td> <td>2ch</td> </tr> <tr> <td>Colour Space</td> <td><u>YCbCr (4:4:4)/YCbCr (4:2:2)/RGB</u></td> </tr> <tr> <td>Video Format</td> <td><u>480i/576i/480p/576p</u> 720p/1080i/1080p</td> </tr> </table>		Audio Stream	<u>PCM</u>	Max Channel	2ch	Colour Space	<u>YCbCr (4:4:4)/YCbCr (4:2:2)/RGB</u>	Video Format	<u>480i/576i/480p/576p</u> 720p/1080i/1080p	<p>Connection status</p> <p>Shows the output signal type.</p> <p>Shows the number of audio channels.</p> <p>(⇒ page 23, HDMI Colour Space)</p> <p>(⇒ page 23, Video Output Mode)</p>
Audio Stream	<u>PCM</u>									
Max Channel	2ch									
Colour Space	<u>YCbCr (4:4:4)/YCbCr (4:2:2)/RGB</u>									
Video Format	<u>480i/576i/480p/576p</u> 720p/1080i/1080p									

**Note**

All possible types of output are displayed.

- The current output for "Audio Stream", "Video Format" and "Colour Space" will be underlined. (If you select a video output without an "\*" mark in the "Video Output Mode" in Picture Menu, the selected video format will not be underlined.)
- When "Off" is selected in "Audio Output" (⇒ page 27, "HDMI" tab), "—" will be displayed in "Audio Stream" and "Max Channel".



# Changing the player settings

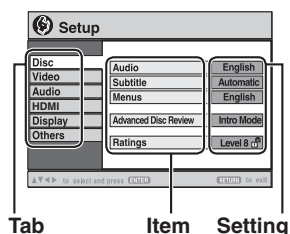

Tab                      Item                      Setting

- If you have not performed QUICK SETUP (→ page 12), the QUICK SETUP screen appears.

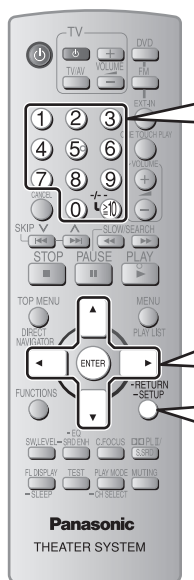

**1 Display the Setup menu.**



**2 Select the tab.**

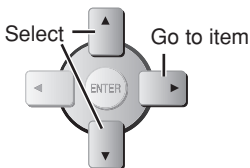

**3 Select the item.**

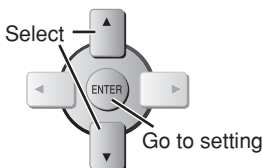

**4 Make the settings.**

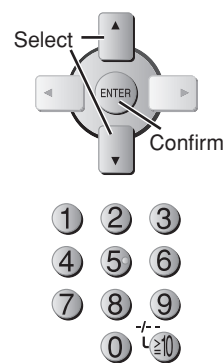

**5 Press to exit.**



- The settings remain intact even if you switch the unit to standby.
- Boxed items are the factory settings in the following table.

**QUICK SETUP enables successive settings of the items in the shaded area.**

## Player settings

### ■ “Disc” tab

<b>Audio</b> Choose the audio language.	• <b>English</b> • (Language options) <sup>×1</sup> • <b>Original</b> <sup>×2</sup> • Other * * * * <sup>×3</sup>
<b>Subtitle</b> Choose the subtitle language.	• <b>Automatic</b> <sup>×4</sup> • English • (Language options) <sup>×1</sup> • Other * * * * <sup>×3</sup>
<b>Menus</b> Choose the language for disc menus. Changing the menu language in QUICK SETUP also changes this setting.	• <b>English</b> • (Language options) <sup>×1</sup> • Other * * * * <sup>×3</sup>
<b>Advanced Disc Review</b> (→ page 22)	• <b>Intro Mode</b> : Reviews each title or program. • <b>Interval Mode</b> : Reviews not only each title or program but also each 10-minute interval within a title or program.
<b>Ratings</b> Set a ratings level to limit DVD-Video play.	Setting ratings (When level 8 is selected) • <b>8 No Limit</b> • 1 to 7 • <b>0 Lock All</b> : To prevent play of discs without rating levels. Changing ratings (When level 0 to 7 is selected) • <b>Unlock Player</b> • <b>Change Password</b> • <b>Change Level</b> • <b>Temporary Unlock</b> When you select your ratings level, a password screen is shown. Follow the on-screen instructions. <b>Do not forget your password.</b> A message screen will be shown if a DVD-Video disc exceeding the ratings level is inserted in the unit. Enter your password and then follow the on-screen instructions.

<sup>×1</sup> Language options : French, German, Italian, Spanish, Polish, Swedish, Dutch

<sup>×2</sup> The original language designated on the disc is selected.

<sup>×3</sup> Input a code number referring to the table (→ page 39).



<sup>×4</sup> If the language selected for “Audio” is not available, subtitle appears in that language (if available on the disc).



**QUICK SETUP** enables successive settings of the items in the shaded area.

**Player settings (continued)**

■ **“Video” tab**

<b>TV Aspect</b> Choose the setting to suit your television and preference.	• <input type="checkbox"/> <b>4:3 Pan&amp;Scan</b> : Regular aspect television (4:3) The sides of the widescreen picture are cut off so it fills the screen (unless prohibited by the disc). 
	• <input type="checkbox"/> <b>4:3 Letterbox</b> : Regular aspect television (4:3) Widescreen picture is shown in the letterbox style. 
	• <input type="checkbox"/> <b>16:9</b> : Widescreen television (16:9)
<b>TV Type</b> Select to suit the type of television.	• <input type="checkbox"/> <b>Standard (Direct View TV)</b> • CRT Projector    • LCD TV/Projector • Projection TV                            • Plasma TV
<b>Time Delay</b> When connected with a Plasma display, adjust if you notice the audio is out of sync with the video.	• <input type="checkbox"/> <b>0ms</b> • 20ms    • 40ms    • 60ms    • 80ms    • 100ms
<b>Video Out (AV/Component)</b> Choose the video signal format to be output from the SCART (AV) and Component terminal.	• Video/YPbPr    • S-Video/YPbPr    • <input type="checkbox"/> <b>RGB/No Output</b>
<b>Still Mode</b> Specify the type of picture shown when paused.	• <input type="checkbox"/> <b>Automatic</b> *5 • <b>Field</b> : The picture is not blurred, but picture quality is lower. *5 • <b>Frame</b> : Overall quality is high, but the picture may appear blurred.
<b>NTSC Disc Output</b> Choose PAL 60 or NTSC output when playing NTSC discs (→ page 14, Video systems).	• <input type="checkbox"/> <b>PAL60</b> : When connected to a PAL television. • <input type="checkbox"/> <b>NTSC</b> : When connected to an NTSC television.

■ **“Audio” tab**

<b>Dolby Digital</b> *6	• <input type="checkbox"/> <b>Bitstream</b> • PCM	Select to suit the type of equipment you connected to the HDMI AV OUT terminal (→ page 11). Select “Bitstream” when the equipment can decode the bitstream (digital form of multi-channel data). Otherwise, select “PCM”. (If the bitstream is output to the equipment without a decoder, high levels of noise can be output and may damage your speakers and hearing.)
<b>DTS Digital Surround</b> *6	• <input type="checkbox"/> <b>Bitstream</b> • PCM	
<b>MPEG</b> *6	• <input type="checkbox"/> <b>PCM</b> • Bitstream	
<b>Dynamic Range Compression</b>	• <input type="checkbox"/> <b>Off</b> • <b>On</b> : Adjust for clarity even when the volume is low by compressing the range of the lowest sound level and the highest sound level. Convenient for late night viewing. (Only works with Dolby Digital)	
<b>Speaker Settings</b> (→ page 28) Set the delay time for your center and surround speakers	• Center: <input type="text" value="0.0"/> /1.0/2.0/3.0/4.0/5.0 ms • Surround (L/R): <input type="text" value="0.0"/> /5.0/10.0/15.0 ms	

\*5 Refer to “Frame still and field still” (→ page 45, Glossary).

\*6 When audio is output from HDMI AV OUT terminal, and the connected equipment does not support the item selected, the actual output will depend on the performance of this connected equipment.





**QUICK SETUP** enables successive settings of the items in the shaded area.

**Player settings (continued)**

■ **“HDMI” tab**

<b>RGB Range</b> Set “HDMI Colour Space” to “RGB” (➔ page 23, Picture Menu).	<ul style="list-style-type: none"> <li>• <input type="checkbox"/> <b>Standard</b></li> <li>• <b>Enhanced</b>: When the black and white images are not distinct.</li> </ul>
<b>Video Mode</b>	<ul style="list-style-type: none"> <li>• <input type="checkbox"/> <b>On</b>: When connect through the HDMI AV OUT terminal. Video is output in 480p/576p/720p/1080p (Progressive) or 480i/576i/1080i (Interlace) according to the setting of the “Video Output Mode” (➔ page 23, Picture Menu).</li> <li>• <input type="checkbox"/> <b>Off</b>: Video is also output from HDMI AV OUT terminal in 480p/576p (Progressive) or 480i/576i (Interlace) according to the setting of the “Video Output Mode” (➔ page 23, Picture Menu).</li> </ul>
<b>Audio Output</b>	<ul style="list-style-type: none"> <li>• <input type="checkbox"/> <b>On</b>: When audio output is from the HDMI AV OUT terminal. (Depending on the capabilities of the connected equipment, audio output may differ from the audio settings of the main unit.)</li> <li>• <input type="checkbox"/> <b>Off</b>: When audio output is not from the HDMI AV OUT terminal. (The audio is output using the settings of the main unit.)</li> </ul>
<b>VIERA Link</b> (“HDAVI Control”)	<ul style="list-style-type: none"> <li>• <input type="checkbox"/> <b>On</b>: The VIERA Link “HDAVI Control” function is available (➔ page 36).</li> <li>• <input type="checkbox"/> <b>Off</b></li> </ul>

■ **“Display” tab**

<b>Menu Language</b>	<ul style="list-style-type: none"> <li>• <input type="checkbox"/> <b>English</b> • Français • Deutsch • Italiano • Español • Polski</li> <li>• Svenska • Nederlands</li> </ul>
<b>On-Screen Messages</b>	<ul style="list-style-type: none"> <li>• <input type="checkbox"/> <b>On</b> • Off</li> </ul>

■ **“Others” tab**

<b>FL Dimmer</b> Change the brightness of the unit’s display.	<ul style="list-style-type: none"> <li>• <input type="checkbox"/> <b>Bright</b> • Dim</li> <li>• <b>Auto</b>: The display is dimmed, but brightens when you perform some operations.</li> </ul>
<b>QUICK SETUP</b>	<ul style="list-style-type: none"> <li>• <input type="checkbox"/> <b>Yes</b> • No</li> </ul>
<b>Re-initialise Setting</b> This returns all values in the Setup menus to the default settings.	<ul style="list-style-type: none"> <li>• <input type="checkbox"/> <b>Yes</b>: The password screen is shown if “Ratings” (➔ page 25) is set. Please enter the same password. After “INIT” on the display disappears, turn the unit off and on again.</li> <li>• <input type="checkbox"/> <b>No</b></li> </ul>



Changing the delay time of the speakers

**Effective when playing multi-channel audio**

(Center and surround speakers only)

For optimum listening with 5.1-channel sound, all the speakers, except for the subwoofer, should be the same distance from the seating position. If you have to place the center or surround speakers closer to the seating position, adjust the delay time to make up for the difference.

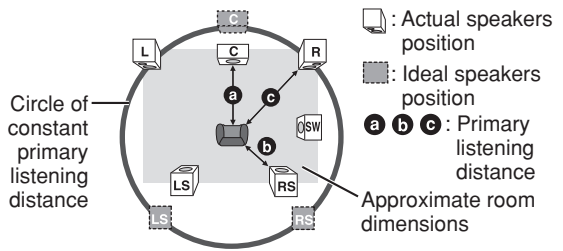

If either distance **a** or **b** is less than **c**, find the difference in the table and change to the recommended setting.

a Center speaker	
Difference (Approx.)	Setting
30 cm	1.0 ms
60 cm	2.0 ms
90 cm	3.0 ms
120 cm	4.0 ms
150 cm	5.0 ms

b Surround speaker	
Difference (Approx.)	Setting
150 cm	5.0 ms
300 cm	10.0 ms
450 cm	15.0 ms

■ To enter the speaker setting

- 1 Press [▲, ▼] to select the delay time box and press [ENTER].
- 2 Press [▲, ▼] to adjust the delay time and press [ENTER].

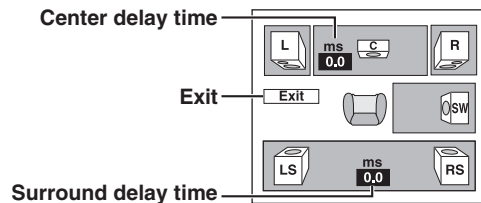

■ To finish the speaker setting

Press [◀] to select "Exit" and press [ENTER].

**Note**

When you change the surround speaker setting for Dolby Digital, the setting also changes for Dolby Pro Logic II.

Example: the settings for MUSIC are the same as those for Dolby Digital.

Dolby Digital	Dolby Pro Logic II	
	MUSIC	MOVIE
0 ms	0 ms	10 ms
5 ms	5 ms	15 ms
10 ms	10 ms	20 ms
15 ms	15 ms	25 ms



## Tips for making data discs

- When there are more than eight groups, the eighth group onwards will be displayed on one vertical line in the menu screen.
- There may be differences in the display order on the menu screen and computer screen.
- This unit cannot play files recorded using packet write.

### DVD-RAM

- Discs must conform to UDF 2.0.

### DVD-R/RW

- Discs must conform to UDF bridge (UDF 1.02/ISO9660).
- This unit does not support multi-session. Only the default session is played.

### CD-R/RW

- Discs must conform to ISO9660 level 1 or 2 (except for extended formats).
- This unit supports multi-session but if there are many sessions it takes more time for play to start. Keep the number of sessions to a minimum to avoid this.

## Naming folders and files

### Files are treated as contents and folders are treated as groups on this unit.

At the time of recording, prefix folder and file names. This should be with numbers that have an equal number of digits, and should be done in the order you want to play them (this may not work at times). Files must have the extension (➔ see below).

#### **WMA** (Extension: “.WMA” or “.wma”)

- Compatible compression rate: between 48 kbps and 320 kbps.
- You cannot play WMA files that are copy-protected.
- This unit does not support Multiple Bit Rate (MBR).

#### **MP3** (Extension: “.MP3” or “.mp3”)

- Compatible compression rate: between 32 kbps and 320 kbps.
- This unit does not support ID3 tags.
- Compatible sampling rates:
  - DVD-RAM, DVD-R/RW: 11.02, 12, 22.05, 24, 44.1 and 48 kHz
  - CD-R/RW: 8, 11.02, 12, 16, 22.05, 24, 32, 44.1 and 48 kHz

#### **JPEG** (Extension: “.JPG”, “.jpg”, “.JPEG” or “.jpeg”)

- JPEG files taken on a digital camera that conform to DCF Standard (Design rule for Camera File system) Version 1.0 are displayed. Files that have been altered, edited or saved with computer picture editing software may not be displayed.
- This unit cannot display moving pictures, MOTION JPEG and other such formats, and still pictures other than JPEG (Example: TIFF), or play pictures with attached audio.

Example: **MP3**

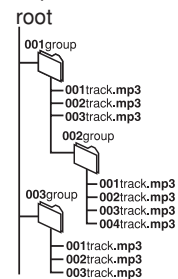

# Using the radio

## Manual tuning

### 1 To select "FM".

SELECTOR (main unit) OR FM (remote control)

### 2 To select "MANUAL".

TUNE MODE-FM MODE (main unit)

### 3 To select the frequency.

∨ TUNE ∧ (main unit) OR SLOW/SEARCH (remote control)

Press and hold [∨ TUNE ∧] until the frequency starts scrolling to start automatic tuning. Tuning stops when a station is found.

### Presetting the channel

#### Remote control only

Up to 30 stations can be set for FM.

- While listening to the radio broadcast Press [ENTER].
- While the frequency and "PGM" are flashing on the display Press the numeric buttons to select a channel.

- To select a 2-digit number Example: To select 12,

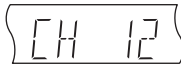

- Alternatively, press [∨, ∧], then press [ENTER].

The station occupying a channel is erased if another station is preset to that channel.

## Selecting the preset channels

### 1 To select "FM".

FM

### 2 To select the channel.

1 TO  $\pm 10$

- Alternatively, press [∨, ∧].
- To perform the step on the main unit, first press [-TUNE MODE] to select "PRESET", and then press [∨ TUNE ∧] to select the channel.

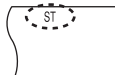

When a stereo FM broadcast is being received, "ST" lights in the display.

### If noise is excessive in FM

#### Main unit only

Press and hold [-FM MODE] to display "MONO".

Press and hold [-FM MODE] again to cancel the mode. The mode is also canceled when you change the frequency.

## Automatic presetting

### 1 To select "FM".

SELECTOR (main unit) OR FM (remote control)

### 2 Press and hold.

MEMORY (main unit) OR ENTER (remote control) Release the button when "FM AUTO" is displayed.

The tuner tunes to the lowest frequency and starts to preset all the stations it can receive into the channels in ascending order.

- "SET OK" is displayed when the stations are set, and the radio tunes to the last preset station.
- "ERROR" is displayed when automatic presetting is unsuccessful. Preset the channels manually (→ see left).

## RDS broadcasting

The unit can display the text data transmitted by the radio data system (RDS) available in some areas.

If the station you are listening to is transmitting RDS signals, "RDS" will light up on the display.

### When "FM" is selected

FUNCTIONS PS (factory preset) → PTY → FREQ

PS : Program service

PTY : Program type

FREQ : Frequency display

### PTY displays

NEWS	VARIED	FINANCE	COUNTRY
AFFAIRS	POP M	CHILDREN	NATIONAL
INFO	ROCK M	SOCIAL A	OLDIES
SPORT	M-O-R- M*	RELIGION	FOLK M
EDUCATE	LIGHT M	PHONE IN	DOCUMENT
DRAMA	CLASSICS	TRAVEL	TEST
CULTURE	OTHER M	LEISURE	ALARM
SCIENCE	WEATHER	JAZZ	

\* "M-O-R- M" = Middle-of-the-Road music

### Note

RDS displays may not be available if reception is poor.



## Using sound effects

### Note

- The following sound effects may not be available or have no effect depending on the type of source, disc as well as recording format or, when headphones are used.
- You may experience a reduction in sound quality when these sound effects are used with some sources. If this occurs, turn the sound effects off.
- It is not possible to turn on Surround Enhancer, EQ and Super Surround at the same time.

### Enhancing the sound from the center speaker: Center Focus

**This applies to discs where the dialogue is recorded in the center channel.**

You can make the sound of the center speaker seem like it is coming from within the television.



C FOCUS ON ↔ C FOCUS OFF

- This also works when Dolby Pro Logic II is turned on.

### Adjusting the amount of bass: Subwoofer level

You can adjust the amount of bass. The unit automatically selects the most suitable setting according to the type of playback source.



- **When AV, AUX or Digital In source is selected**

SUB W 1 (factory preset) → SUB W 2  
 ↳ SUB W 4 ← SUB W 3 ←

- **When another source is selected**

SUB W 2 (factory preset) → SUB W 3  
 ↳ SUB W 1 ← SUB W 4 ←

- To check the current setting, press [SW.LEVEL].
- The setting you make is retained, and recalled every time you play the same type of source.

### Enhancing the surround sound effect: Surround Enhancer

Automatically adjusts each speaker to enhance the surround sound effect of multi-channel audio. When playing two-channel audio, the audio of the L/R front speakers is also output through the rest of the speakers creating a surround sound effect.



(Press and hold)



SRD ENH ON ↔ SRD ENH OFF

### Changing the sound quality: Equalizer Mode (EQ)



**HEAVY** : Adds punch to rock.

**CLEAR** : Clarifies higher sounds.

**SOFT**\* : For background music.

**FLAT** : Cancel (no effect is added) (factory preset).

- To check the current setting, press [-EQ].
  - You can adjust the volume of the surround speakers to get the best surround effect (➔ page 32, Adjusting the volume of each speaker: Speaker level adjustments).
  - It is not possible to turn on EQ and Sound Enhancer at the same time.
- \* Factory preset when AV, AUX or Digital In source is selected.

### Enhancing the stereo sound: Super Surround



**Movie** : Use this mode when playing movie software.

**Music** : Adds surround effects to stereo sources.

**Off** : Cancel

- This works only in FM, AV, Music P. and AUX mode.
- Super Surround and EQ can be turned on simultaneously.



### Enhancing the stereo sound: Dolby Pro Logic II

Dolby Pro Logic II is an advanced decoder that derives 5-channel surround (Left and Right Front, Center, Left and Right Surround) from stereo sound sources, whether or not it has been specifically Dolby Surround encoded.



**Movie** : Movie software, recorded in Dolby Surround.

**Music** : Stereo sources

**Off** : Cancel

- This works only in DVD/CD, USB and Digital In mode.
- “DOL PLII” lights when there is an effect.
- This does not work when audio is output from HDMI AV OUT terminal.

### Adjusting the volume of each speaker: Speaker level adjustments

This is one of the ways to get appropriate surround effects.

#### Preparation



- 1 While stopped and no on-screen display is shown  
To output a test signal.



L: Front left                      C: Center  
R: Front right                    RS: Right surround  
LS: Left surround

- There is no output from SW (subwoofer) channel.

- 2 To set the volume level normally used for listening.



- 3 To adjust the speaker level for each speaker.



- Adjust the speaker levels to the same level as the front speakers.  
C, RS, LS: -6 dB to +6 dB

#### To stop the test signal

Press [TEST] again.

### To adjust speaker level during play

[Effective when playing multi-channel audio or when Dolby Pro Logic II is on.]

1. Press and hold [-CH SELECT] to select the speaker.

L → C → R → RS → LS → SW



SW: Subwoofer

- You can adjust SW only if the disc includes a subwoofer channel.
  - “SW” does not appear on the display and is not adjustable when “DOL PLII” is lit.
  - “S” appears on the display when “MOVIE”, “MUSIC” is selected with Super Surround (➡ page 31).  
In this case, you can adjust both surround speaker levels at the same time using [▲, ▼].  
S: -6 dB to +6 dB
2. Press [▲] (increase) or [▼] (decrease) to adjust the speaker level for each speaker.  
C, RS, LS, SW: -6 dB to +6 dB  
(L, R: Only the balance is adjustable.)
  - To adjust the balance of the front speakers, while “L” or “R” is selected, press [◀, ▶].



## Operating other equipment

### Optional antenna connection

Use the outdoor antenna if radio reception is poor.

#### FM outdoor antenna (Using a television antenna)

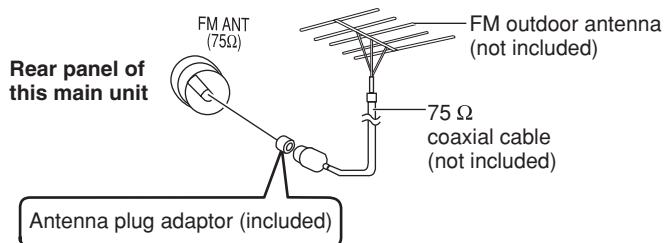

- Disconnect the FM indoor antenna.
- The outdoor antenna should be installed by a competent technician.

#### Note

- Disconnect the outdoor antenna when the unit is not in use.
- Do not use the outdoor antenna during a lightning storm.

### Optional connection for set top box

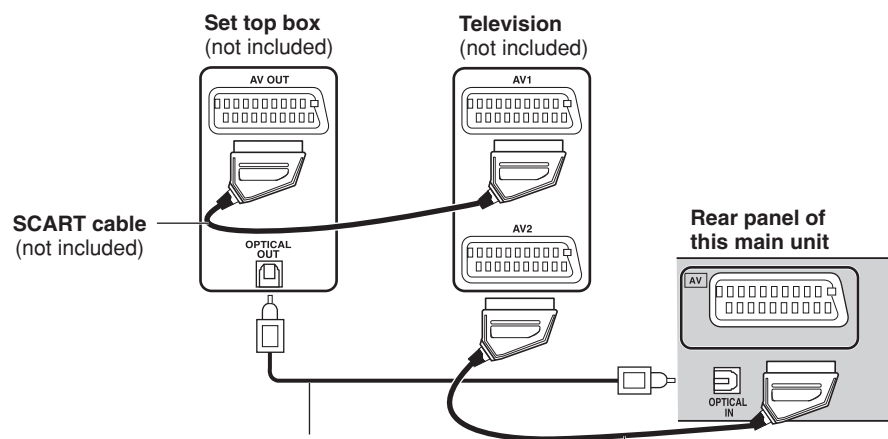

**Optical digital audio cable** (not included)  
• Do not bend sharply when connecting.

**SCART cable** (not included)  
• To listen to the sound from the television, select the appropriate audio out (example: Monitor) on the television.

**Sound from the television**  
• Press [EXT-IN] (⇒ page 38) to select the “AV” audio input on the remote control.

#### Optical-In for 5.1 ch surround

This unit can decode the surround signal from the set top box. Press [EXT-IN] to select “D-IN” audio input on the remote control.

- Optical input settings (⇒ page 38)

You can change the video signal output from the SCART (AV) terminal from “RGB” to either “S-Video” or “Video” to suit the type of television you are using.

- Select “S-Video/YPbPr” or “Video/YPbPr” from QUICK SETUP (⇒ page 12).
- Set “Video Mode” to “Off” (⇒ page 27, “HDMI” tab).
- This connection will also enable you to play audio from your television through your home theater system. Refer to “Operating other equipment” (⇒ page 34).
- Do not use the HDMI cable when you use the scart cable for the connection.





## Connecting with your HDMI-compatible television and set top box

- Do not use the SCART cable when the HDMI cable is being used for connection.
- When the HDMI cable is connected, there will be no video output from the SCART and COMPONENT VIDEO OUT terminals of the main unit.
- Do not connect any kind of audio/video distribution devices between this unit and the television (such as an amplifier, etc.).
- Set “Video Mode” to “On” and “Audio Output” to “On” (⇒ page 27, “HDMI” tab).
- Set “Video Output Mode” (⇒ page 23, Picture Menu).

### Optical-In for 5.1 ch surround

This unit can decode the surround signal from the set top box. Press [EXT-IN] to select “D-IN” audio input on the remote control.

- Optical input settings (⇒ page 38)

Rear panel of this main unit

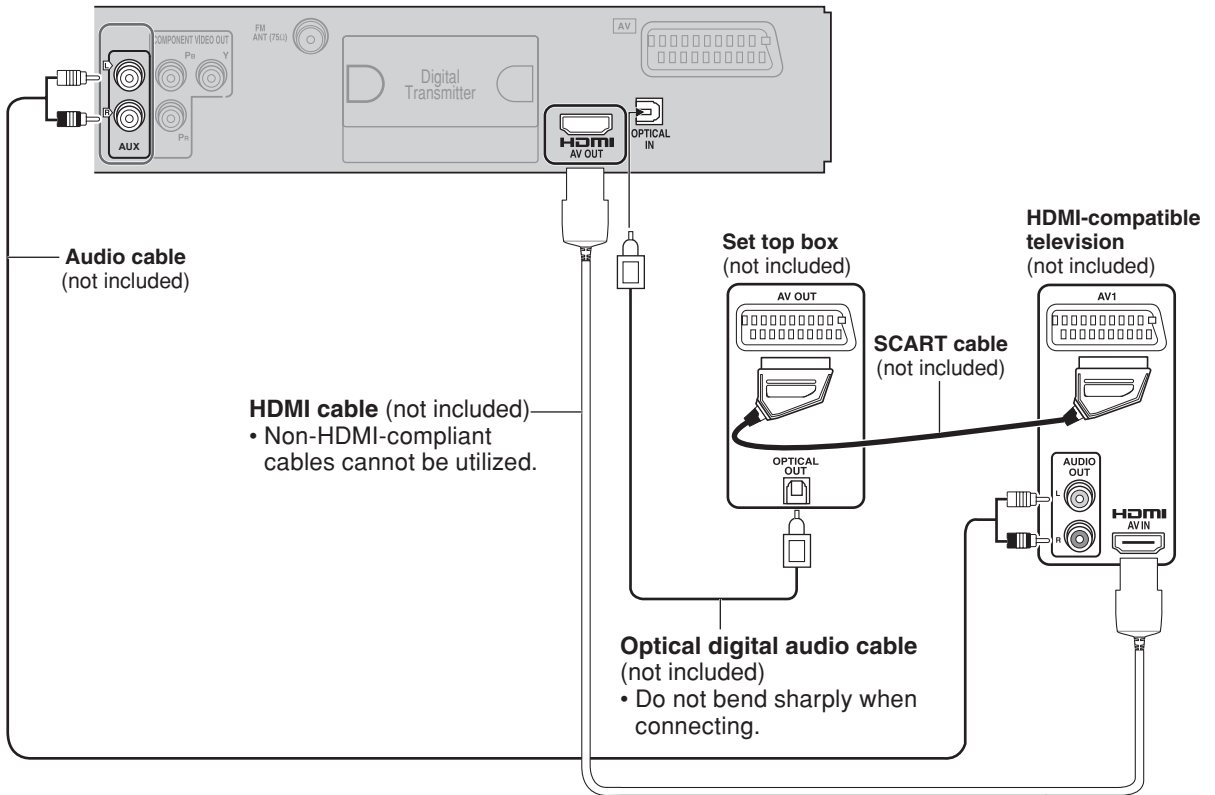

## Optional audio connection for video cassette recorder or television

Press [EXT-IN] (⇒ page 15) to select “AUX” as the source to operate the audio input.

**This audio connection will enable you to play audio from your video cassette recorder or television through your home theater system.**

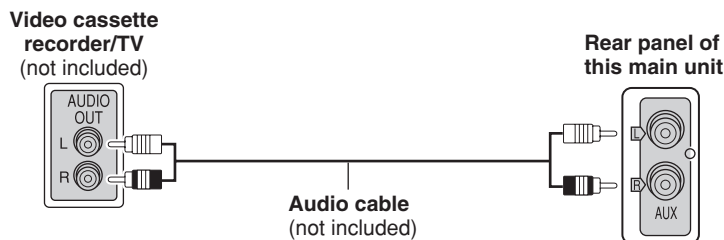

## Optional Music Port connection and operation

The Music Port allows you to connect and enjoy music from an external device (example: MP3 player) through your home theater system.

### Preparation

To avoid distorted sound, make sure that any equalizer function of your external device is turned off.

#### 1 Reduce the volume and connect the external device (not included).

Plug type: Ø3.5 mm stereo mini plug

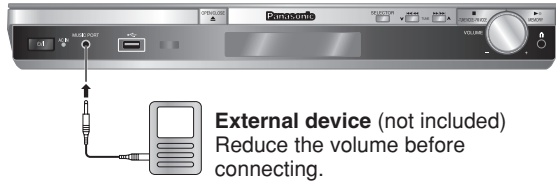

#### 2 To select "MUSIC P.".



USB → AV → AUX → D-IN (Digital In)  
↑ MUSIC P. ←

#### 3 Adjust the external device volume to a normal listening level, and then adjust the volume of the main unit.



- You can enjoy surround sound when you turn on Super Surround (MOVIE, MUSIC) (→ page 31).

## Optional USB connection and operation

WMA MP3 JPEG

The USB connectivity enables you to connect and play tracks or files from USB mass storage class devices. Typically, USB memory devices. (Bulk only transfer)

### Preparation

Before connecting any USB mass storage device to the unit, ensure that the data stored therein has been backed up.

It is not recommended to use a USB extension cable. The USB device is not recognised by this unit.

#### 1 Connect the USB mass storage device (not included).

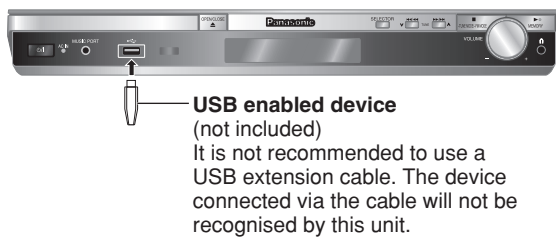

Example:

Playback Menu		USB
All	Total 86	
Audio	Total 58	
Picture	Total 28	

▲▼ to select and press [ENTER]

#### 3 Adjust the volume of the main unit.



#### 4 Begin playback by selecting the track from the USB mass storage device.

**To return to the previous screen**

Press [-RETURN]

For other operating functions, they are similar as those described in "DISC OPERATIONS" (→ page 16 to 29).

#### 2 To select "USB" as the source, press several times.

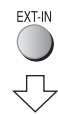

USB → AV → AUX → D-IN (Digital In)  
↑ MUSIC P. ←



**Optional USB connection and operation (continued)**

**Compatible Devices**

- **Devices which are defined as USB mass storage class:**
  - USB devices that support bulk only transfer.
  - USB devices that support USB 2.0 full speed.

**Supported Formats**

	File name	File extension
Still pictures	JPG	.jpg .jpeg
Music	MP3 WMA	.mp3 .wma

**Note**

- CBI (Control/Bulk/Interrupt) is not supported.
- Digital Cameras that use PTP protocol or which require additional program installation when connected to a PC are not supported.
- A device using NTFS file system is not supported. [Only FAT 12/16/32 (File Allocation Table 12/16/32) file system is supported].
- Depending on the sector size, some files may not work.
- It will not operate with Janus enabled MTP (Media Transfer Protocol) devices.
- Maximum folder: 400 folders
- Maximum file: 4000 files
- Maximum file name: 44 characters
- Maximum folder name: 44 characters
- Only one memory card will be selected when connecting a multi-port USB card reader. Typically the first memory card inserted.

**Using the VIERA Link “HDAVI Control™”**

**What is VIERA Link “HDAVI Control”?**

VIERA Link “HDAVI Control” is a convenient function that offers linked operation of this unit, and a Panasonic television (VIERA) under “HDAVI Control”. You can use this function by connecting the equipment with the HDMI cable. See the operating instructions for connected equipment for operational details.

This unit supports “HDAVI Control 2” function. The TV with “HDAVI Control 2” function enables the following operation:

VIERA Link Control only with TV’s remote control (for “HDAVI Control 2”) (→ page 37)

**Preparation**

- Confirm that the HDMI connection (→ page 11) has been made.
- Set “VIERA Link” to “On” (→ page 27, “HDMI” tab).
- To complete and activate the connection correctly, turn on all VIERA Link HDAVI Control compatible equipment and set the television to the corresponding HDMI input mode for the home theater system.
- Whenever the connection or settings are changed, reconfirm the points above.

**One Touch Play**

You can turn on the home theater system and television, and start playing the disc in the play position with a single press of a button.

ONE TOUCH PLAY



Theater speakers will be automatically activated (→ page 37).

- This function also works if you press [▶, PLAY] on the home theater remote control during home theater standby mode.

**Note**

Playback may not be immediately displayed on the television. If you miss the beginning portion of playback, press [◀◀] or [◀] to go back to where playback started.

**Auto input switching**

- When you switch the television input to:
    - TV tuner mode, the home theater system will automatically switch to “AUX”<sup>※</sup> or “D-IN”<sup>※</sup>.
    - HDMI input mode for the home theater system, the home theater system will automatically switch to “DVD/CD” if it is in “AUX”<sup>※</sup> or “D-IN”<sup>※</sup> mode.
  - When you start disc play, the television will automatically switch to the HDMI input mode for the home theater system.
- <sup>※</sup>To toggle the mode that this function works with, press [–SETUP] while the main unit is in “AUX” or “D-IN” mode.
- The default setting is “AUX”.



## Using the VIERA Link "HDAVI Control™" (continued)

### Speaker control

You can select whether audio is output from the home theater system or the television speakers by using the television menu settings. For details, refer to the operating instructions of your television.

### Home Cinema

Theater speakers are active.

- When the home theater system is in standby mode, changing the television speakers to theater speakers in the television menu will automatically turn the home theater system on and select "AUX"\* or "D-IN"\* as the source.
- The television speakers are automatically muted.
- You can control the volume setting using the volume or mute button on the TV's remote control. (The volume level is displayed on the main unit's FL display.)
- To cancel muting, you can also use the home theater remote control (➔ page 15).
- If you turn off the home theater system, television speakers will be automatically activated.

### TV

Television speakers are active.

- The volume of the home theater system is set to "0".
  - This function works only when "DVD/CD", "USB", "AUX"\* or "D-IN"\* is selected as the source on the home theater system.
- Audio output is 2-channel audio.

- When switching between the theater and television speakers, the TV screen may be blank for several seconds.

\*To toggle which input source the main unit will automatically switch to, press [-SETUP] while the main unit is in "AUX" or "D-IN" mode.  
– The default setting is "AUX".

### Power off link

When the television is turned off, the home theater system goes into standby mode automatically.

- This function works only when "DVD/CD", "USB", "AUX"\* or "D-IN"\* is selected as the source on the home theater system.
- When the television is turned on, the home theater system does not turn on automatically. (Power on link is not available.)

\*For "AUX" or "D-IN" mode, power off link can be set to work with one or the other. To toggle the mode that this function works with, press [-SETUP] while the main unit is in "AUX" or "D-IN" mode.  
– The default setting is "AUX".

### Note

Only the home theater system turns off when you press [⏻] for shutting it down. Other connected equipment compatible with VIERA Link "HDAVI Control" stay on.

### VIERA Link Control only with TV's remote control (for "HDAVI Control 2")

You can control the disc menus of the home theater system with the TV's remote control when using the "DVD/CD" or "USB" source. When operating the TV's remote control, refer to the below illustration for operation buttons.

1. Select the theater operation menu by using the television menu settings.

(For details, refer to the operating instructions of your television.)

- The home theater system will automatically switch to "DVD/CD" if it is in "AUX"\* or "D-IN"\* mode.

\*To toggle the mode that this function works with, press [-SETUP] while the main unit is in "AUX" or "D-IN" mode.

– The default setting is "AUX".

2. Select the desired item.

- "TOP MENU" : Shows a disc top menu (➔ page 17, 19) or program list (➔ page 20).



- "MENU" : Shows a disc menu (➔ page 17, 20) or play list (➔ page 20).

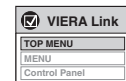

- "Control Panel": The basic operations for discs are available.

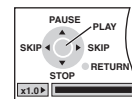

### Note

- Depending on the menu, some button operations cannot be performed from the TV's remote control.
- "Control Panel" can be selected directly by using a button on the TV's remote control (e.g. [OPTION]).



## Operating the television

You can use the remote control to operate a Panasonic television.  
Aim the remote control at the television.

### To switch the television on or off



### To switch the television's video input mode



### Adjust the volume



### To play audio from your television through your home theater system

#### Preparation

Connect your equipment referring to "Connect to the various television terminals" (⇒ page 11).

Press [EXT-IN] to select "AV" as the source. Then reduce the volume on the television to its minimum, and control the volume on this main unit.

#### Note

- The remote control may not work properly with some models.
- You can enjoy 5.1-channel surround sound when you turn on Super Surround (MOVIE, MUSIC) (⇒ page 31).

## Operating the cable TV box, digital broadcasting or satellite receiver

This unit can decode the surround signals received through cable TV box, digital broadcasting or satellite broadcasts. Refer to your equipment's operating instructions for details. Only Dolby Digital and PCM can be played with this connection.

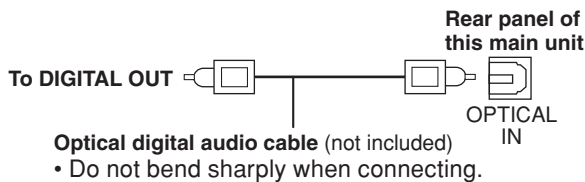

**To select "D-IN" (Digital In) as the source, press several times.**

EXT-IN



USB → AV → AUX → **D-IN** (Digital In)  
                                  ↑                                  ↓  
                                  MUSIC P. ←                                  →

**When you select "D-IN" as the source, you can select the following sound effects.** (These functions only work with Dolby Digital or PCM, excluding Audio Mode, which only works with Dolby Digital Dual Mono.)

#### PCM FIX Mode

Press and hold [▶].  
(remote control)

**PFIFF ON:** Select when receiving only PCM signals.

**PFIFF OFF** (factory preset): Select when receiving Dolby Digital and PCM signals.

#### Dynamic Range Compression

Press and hold [◀].

**DRC ON:** Adjusts for clarity even when the volume is low by compressing the range of the lowest sound level and the highest sound level. Convenient for late night viewing. (Only works with Dolby Digital)

**DRC OFF** (factory preset)

#### Audio Mode

Press and hold [▲]

**AUDIO ST, AUDIO L, AUDIO R** ("AUDIO L" and "AUDIO R" only appear when the signal is Dolby Digital Dual Mono.)

#### Dolby Pro Logic II (⇒ page 32)

Press [DOLPLII].

#### Note

Audio that is input through the OPTICAL IN terminal cannot be output through the HDMI terminal.



## Changing the main unit and remote control

The remote control and main unit are factory-set to "REMOTE 1" mode.

If your remote control affects other equipment during operation, you can switch to operate in "REMOTE 2" mode.

### To switch to "REMOTE 2" mode

**1** While pressing and holding [▶▶/▶▶] on the main unit

**2**

"REMOTE 2" appears on the main unit display.

**2** To operate in "REMOTE 2" mode

 + **2**

(Press and hold for 2 seconds)

### To return to "REMOTE 1" mode

Perform steps 1 and 2 but use [1] instead of [2] for both steps. ("REMOTE 1" appears on the main unit during step 1.)

**The remote control cannot work with the main unit if their modes are different.**

"REMOTE 1" or "REMOTE 2" appears on the main unit display when you operate the remote control.

• If "REMOTE 1" appears (The main unit is in "REMOTE 1" mode.)

Press and hold [ENTER] and [1] on the remote control for at least 2 seconds.

If "REMOTE 2" appears (The main unit is in "REMOTE 2" mode.)

Press and hold [ENTER] and [2] on the remote control for at least 2 seconds.

### Note

You can still operate a television using the remote control (→ page 38) even after switching the mode.

## Language code list

Abkhazian: 6566	Danish: 6865	Italian: 7384	Norwegian: 7879	Swedish: 8386
Afar: 6565	Dutch: 7876	Japanese: 7465	Oriya: 7982	Tagalog: 8476
Afrikaans: 6570	English: 6978	Javanese: 7487	Pashto, Pushto: 8083	Tajik: 8471
Albanian: 8381	Esperanto: 6979	Kannada: 7578	Persian: 7065	Tamil: 8465
Ameharic: 6577	Estonian: 6984	Kashmiri: 7583	Polish: 8076	Tatar: 8484
Arabic: 6582	Faroese: 7079	Kazakh: 7575	Portuguese: 8084	Telugu: 8469
Armenian: 7289	Fiji: 7074	Kirghiz: 7589	Punjabi: 8065	Thai: 8472
Assamese: 6583	Finnish: 7073	Korean: 7579	Quechua: 8185	Tibetan: 6679
Aymara: 6589	French: 7082	Kurdish: 7585	Rhaeto-Romance: 8277	Tigrinya: 8473
Azerbaijani: 6590	Frisian: 7089	Laotian: 7679	Romanian: 8279	Tonga: 8479
Bashkir: 6665	Galician: 7176	Latin: 7665	Russian: 8285	Turkish: 8482
Basque: 6985	Georgian: 7565	Latvian, Lettish: 7686	Samoan: 8377	Turkmen: 8475
Bengali; Bangla: 6678	German: 6869	Lingala: 7678	Sanskrit: 8365	Twi: 8487
Bhutani: 6890	Greek: 6976	Lithuanian: 7684	Scots Gaelic: 7168	Ukrainian: 8575
Bihari: 6672	Greenlandic: 7576	Macedonian: 7775	Serbian: 8382	Urdu: 8582
Breton: 6682	Guarani: 7178	Malagasy: 7771	Serbo-Croatian: 8372	Uzbek: 8590
Bulgarian: 6671	Gujarati: 7185	Malay: 7783	Shona: 8378	Vietnamese: 8673
Burmese: 7789	Hausa: 7265	Malayalam: 7776	Sindhi: 8368	Volapük: 8679
Byelorussian: 6669	Hebrew: 7387	Maltese: 7784	Singhalese: 8373	Welsh: 6789
Cambodian: 7577	Hindi: 7273	Maori: 7773	Slovak: 8375	Wolof: 8779
Catalan: 6765	Hungarian: 7285	Marathi: 7782	Slovenian: 8376	Xhosa: 8872
Chinese: 9072	Icelandic: 7383	Moldavian: 7779	Somali: 8379	Yiddish: 7473
Corsican: 6779	Indonesian: 7378	Mongolian: 7778	Spanish: 6983	Yoruba: 8979
Croatian: 7282	Interlingua: 7365	Nauru: 7865	Sundanese: 8385	Zulu: 9085
Czech: 6783	Irish: 7165	Nepali: 7869	Swahili: 8387	





## Troubleshooting guide

Before requesting service, make the following checks. If you are in doubt about some of the check points, or if the solutions indicated in the chart do not solve the problem, consult your dealer for instructions.

■ Power		Page
<b>No power.</b>	• Insert the AC mains lead securely.	10
<b>The unit is automatically switched to the standby mode.</b>	• The Sleep timer was working and had reached the set time limit.	15

### ■ Unresponsive or inoperable function

<b>No response when any buttons are pressed.</b>	<ul style="list-style-type: none"> <li>• This unit cannot play discs other than the ones listed in these operating instructions.</li> <li>• The unit may not be operating properly due to lightning, static electricity or some other external factor. Turn the unit off and then back to on. Alternatively, turn the unit off, disconnect the AC mains lead, and then reconnect it.</li> <li>• Condensation has formed: Wait 1 to 2 hours for it to evaporate.</li> </ul>	13 — —
<b>No response when remote control buttons are pressed.</b>	<ul style="list-style-type: none"> <li>• Check that the batteries are installed correctly.</li> <li>• The batteries are depleted. Replace them with new ones.</li> <li>• Aim the remote control at the remote control signal sensor and operate.</li> </ul>	6 6 14
<b>Other products respond to the remote control.</b>	• Change the remote control operating mode.	39
<b>No picture or sound.</b>	<ul style="list-style-type: none"> <li>• Check the video or speaker connection.</li> <li>• Check the power or input setting of the connected equipment and the main unit.</li> <li>• Check that the disc has something recorded on it.</li> <li>• While the HDMI cable is being used, there will be no video output from the SCART and COMPONENT VIDEO OUT terminals. If the SCART and COMPONENT VIDEO OUT terminals are to be used, remove the HDMI cable and power on/off the main unit again.</li> </ul>	10, 11 — — —
<b>You have forgotten your ratings password.</b> Reset all the settings to Factory Preset.	• While stopped and "DVD/CD" is the source, press and hold [■] on the main unit and [≥10] on the remote control until "Initialised" disappears from the television. Turn the unit off and on again. All settings will return to the default values.	—
<b>The VIERA Link function does not respond.</b>	• Depending on the condition of the home theater system or the connected equipment, it may be necessary to repeat the same operation so that the function can work correctly.	36

ENGLISH

REFERENCE



### ■ Subtitle

<b>Subtitle position is wrong.</b>	• Adjust the position. ("Subtitle Position" in Display Menu)	24
<b>No subtitles.</b>	• Display the subtitles. ("Subtitle" in Functions Menu)	22
<b>Subtitles overlap the closed captions.</b>	• Clear the subtitles.	22

RQTX0059



■ Specific operation undesirable or unexpected		Page
<b>It takes time before play starts.</b>	<ul style="list-style-type: none"> <li>• Play may take time to begin when an MP3 track has still picture data. Even after the track starts, the correct play time will not be displayed. This is normal. <b>[MP3]</b></li> </ul>	—
<b>Folders on a data CD are not displayed correctly.</b> <b>[WMA]</b> <b>[MP3]</b> <b>[JPEG]</b>	<ul style="list-style-type: none"> <li>• Folders deeper than the eighth layer are displayed as the eighth layer.</li> </ul>	—
<b>A menu screen appears during skip or search.</b> <b>[VCD]</b>	<ul style="list-style-type: none"> <li>• This is normal for Video CDs.</li> </ul>	—
<b>Playback control menu does not appear.</b> <b>[VCD]</b> with playback control	<ul style="list-style-type: none"> <li>• Press <b>[■, STOP]</b> twice and then press <b>[▶, PLAY]</b>.</li> </ul>	—
<b>The program and random play functions do not work.</b> <b>[DVD-V]</b>	<ul style="list-style-type: none"> <li>• These functions do not work with some DVD-Videos.</li> </ul>	—
<b>Play does not start.</b>	<ul style="list-style-type: none"> <li>• This unit may not play WMA that contains still picture data.</li> <li>• If a disc contains CD-DA and other formats, proper playback may not be possible.</li> </ul>	— —

#### ■ Sound abnormal or improper

<b>Sound is distorted.</b>	<ul style="list-style-type: none"> <li>• Noise may occur when playing WMA.</li> <li>• When using the HDMI output, audio may not be output from other terminals.</li> </ul>	— —
<b>Effects do not work.</b>	<ul style="list-style-type: none"> <li>• Some audio effects do not work or have less effect with some discs.</li> <li>• Dolby Pro Logic II does not work if you have changed the play speed.</li> </ul>	— —
<b>Humming is heard during play.</b>	<ul style="list-style-type: none"> <li>• An AC mains lead or fluorescent light is near the main unit. Keep other appliances and cables away from the main unit.</li> </ul>	—
<b>No sound.</b>	<ul style="list-style-type: none"> <li>• There may be a slight pause in sound when you change the play speed.</li> <li>• Ensure that the wireless system is connected to the mains socket, and <b>[W1]</b> is displayed on the main unit's display.</li> <li>• Audio may not be heard when more than 4 devices are connected with HDMI cables. Reduce the number of connected devices.</li> <li>• When using the HDMI connection, ensure that "Audio Output" in the "HDMI" tab is set to "On".</li> </ul>	— — — 27

#### ■ A-B repeat

<b>Point B is automatically set.</b>	<ul style="list-style-type: none"> <li>• The end of an item becomes point B when it is reached.</li> </ul>	—
--------------------------------------	--	---





■ Menus		Page
<b>The Setup menu cannot be accessed.</b>	<ul style="list-style-type: none"> <li>• Select “DVD/CD” as the source.</li> <li>• Cancel program and random play.</li> </ul>	— 18

■ Picture abnormal or unviewable

<b>The picture on the television is not displayed correctly or disappears.</b>	• The unit and television are using different video systems. Use a multi-system or PAL television.	—
	• The system used on the disc does not match your television. –PAL discs cannot be correctly viewed on an NTSC television. –This unit can convert NTSC signals to PAL 60 for viewing on a PAL television (“NTSC Disc Output” in “Video” tab).	— 26
	• Ensure that the unit is connected directly to the television, and is not connected through a video cassette recorder.	33
	• Mobile telephone chargers can cause some disturbance.	—
	• If you are using an indoor television antenna, change to an outdoor antenna.	—
	• The television antenna wire is too close to the unit. Move it away from the unit.	—
	• Picture may not be seen when more than 4 devices are connected with HDMI cables. Reduce the number of connected devices.	—
	• When using HDMI output, the video signal is progressive. Use other video connections if your television is not compatible with progressive video.	11
	• If the picture is distorted or not displayed when using HDMI output, press and hold [CANCEL] until the picture is displayed correctly. (The output will return to “480p” or “576p”.)	—
	• When using the COMPONENT VIDEO OUT terminal, ensure that progressive output is not selected when the connected television is not progressive compatible. Press and hold [CANCEL] until the picture is displayed correctly. (The output will return to “480i” or “576i”.)	23
	• When using SCART (AV) terminal, set “Video mode” in the “HDMI” tab to “Off”.	27
	• When using component terminal, set “Video out (AV/Component)” in “Video” tab to “Video/YPbPr” or “S-Video/YPbPr”.	27
	<b>Picture size does not fit the screen.</b>	• Change “TV Aspect” in the “Video” tab.
• Use the television to change the aspect. If your television does not have that function, change “4:3 Aspect” in Display Menu.		24
• Change the zoom setting. (“Just Fit Zoom” or “Manual Zoom” in Display Menu)		24
<b>Menu is not displayed correctly.</b>	• Restore the zoom ratio to “x 1.00”. (“Manual Zoom” in Display Menu)	24
	• Set “Subtitle Position” in Display Menu to “0”.	24
	• Set “4:3 Aspect” in Display Menu to “Normal”.	24
<b>Auto zoom function does not work well.</b>	• Turn off television zoom function.	—
	• Use the other preset aspect ratios or manual adjustment.	24
	• Zoom function may not work well, especially in dark scenes and may not work depending on the type of disc.	—
<b>When playing PAL disc, picture is distorted.</b>	• Set “Transfer Mode” in Picture Menu to “Auto”.	23



■ Progressive video		Page
There is ghosting when progressive or HDMI output is on.	• This problem is caused by the editing method or material used on DVD-Video, but should be corrected if you use interlaced output. Set "Video Output Mode" in Picture Menu to "480i" or "576i". (Alternatively, press and hold [CANCEL] to switch to "480i" or "576i".)	23
	• Disable the HDMI AV OUT connection and use other video connections. Make the settings in the following order: 1 Set "Video Mode" in the "HDMI" tab to "Off". 2 Set "Video Output Mode" in Picture Menu to "480i" or "576i". (Alternatively, press and hold [CANCEL] to switch to "480i" or "576i".)	27 23
Pictures not in progressive output.	• Select "480p" or "576p" in "Video Output Mode" in Picture Menu. • The unit's SCART (AV) terminal outputs an interlaced signal even if "PRG" is displayed.	23
Closed captions not displayed.	• When HDMI or progressive output is on, closed captions will not be displayed.	—

### ■ Unit displays

The display is dark.	• Select "Bright" in "FL Dimmer" in the "Others" tab.	27
"NO PLAY"	• You inserted a disc the unit cannot play; insert one it can.	13
	• You inserted a blank disc.	—
	• You inserted a disc that has not been finalized.	—
"NO DISC"	• You have not inserted a disc; insert one.	—
	• You have not inserted the disc correctly; insert it correctly.	16
"OVER CURRENT ERROR"	• The USB device is drawing too much power. Switch to DVD/CD mode, remove the USB and turn the unit off.	—
"F61"	• Check and correct the speaker cable connections. If this does not fix the problem, consult the dealer.	10
"F76"	• There is a power supply problem. Consult the dealer.	—
"DVD U11"	• Disc may be dirty. Wipe it clean.	14
"ERROR"	• Incorrect operation performed. Read the instructions and try again.	—
"DVD H □ □" "DVD F □ □ □" □ stands for a number.	• Trouble may have occurred. The numbers following "H" and "F" depend on the status of the unit. Turn the unit off and then back on. Alternatively, turn the unit off, disconnect the AC mains lead, and then reconnect it.	—
	• If the service numbers fail to clear, note the service number and contact a qualified service person.	—
"[W1]" is flashing.	• There is no link between the main unit and the wireless accessory. Check that the wireless accessory is plugged into the mains socket.	9
	• Ensure that the digital transmitter is fully inserted into the slot of the main unit.	9
"U70 □" □ stands for a number. The actual number following "U70" will depend on the state of the main unit.	• The HDMI connection acts unusually.	39
	–The connected equipment is not HDMI-compatible.	—
	–The HDMI cable is too long. –The HDMI cable is damaged.	— —
"REMOTE 1" or "REMOTE 2"	• Match the modes on the main unit and remote control. Depending on the number being displayed ("1" or "2"), press and hold [ENTER] and the corresponding numbered button ([1] or [2]) for at least 2 seconds.	39





## Troubleshooting (continued)

■ Television displays		Page
“⊘”	• The operation is prohibited by the unit or disc.	—
“Cannot play group xx, content xx” “Cannot display group xx, content xx”	• You are trying to display an incompatible group or content.	—
“Group xx, content xx is protected”	• You are trying to play a protected group or content. You cannot play it.	—
“Check the disc”	• This disc may be dirty.	—
“This disc may not be played in your region”	• Only DVD-Video discs that include or have the same region number as the one on the rear panel of this unit can be played.	Cover page
No on-screen display.	• Select “On” in “On-Screen Messages” in the “Display” tab.	27
Main unit’s screen saver remains.	• When using the HDMI connection, audio/video information is continually transferred between the main unit and the television regardless of which source has been selected on the main unit. This is normal.	—

### ■ USB

The USB drive or its contents cannot be read.	• The USB drive format or its contents is/are not compatible with the system.	—
	• The USB host function of this product may not work with some USB devices.	—
	• USB devices with storage capacity of more than 32 GB may not work in some instances.	—
Slow operation of the USB device.	• Large file size or high memory USB flash drive takes longer time to read and display on the TV.	—

### ■ Listening to the radio

Distorted sound or noise is heard. “ST” flickers or does not light.	• Adjust the position of the FM antenna.	— 33
	• Use an outdoor antenna.	
A beat sound is heard.	• Turn the television off or move it away from the unit.	—



## Maintenance

### Clean this unit with a soft, dry cloth.

- Never use alcohol, paint thinner or benzine to clean this unit.
- Before using chemically treated cloth, carefully read the instructions that came with the cloth.
- Do not use commercially available lens cleaners as they may cause malfunction. (Cleaning the lens is generally not necessary although this depends on the operating environment.)

### Before moving the unit, ensure the disc tray is empty.

Failure to do so will risk severely damaging the disc and the unit.

**Decoder**

A decoder restores the coded audio signals on DVDs to normal. This is called decoding.

**Dolby Digital**

This is a method of coding digital signals developed by Dolby Laboratories. Apart from stereo (2-channel) audio, these signals can also be multi-channel audio. A large amount of audio information can be recorded on one disc using this method.

**DTS (Digital Theater Systems)**

This surround system is used in many movie theaters around the world. There is good separation between the channels, so realistic sound effects are possible.

**Dynamic range**

Dynamic range is the difference between the lowest level of sound that can be heard above the noise of the equipment and the highest level of sound before distortion occurs.

**Film and video**

DVD-Videos are recorded using either film or video. This unit can determine which type has been used, then uses the most suitable method of progressive output.

**Film:** Recorded at 25 frames per second (PAL discs) or 24 frames per second (NTSC discs). (NTSC discs recorded at 30 frames per second as well). Generally appropriate for motion picture films.

**Video:** Recorded at 25 frames/50 fields per second (PAL discs) or 30 frames/60 fields per second (NTSC discs). Generally appropriate for TV drama programs or animation.

**Frame still and field still**

Frames are the still pictures that go together to make a moving picture.

There are about 30 frames shown each second. One frame is made up of two fields. A regular television shows these fields one after the other to create frames.

A still is shown when you pause a moving picture. A frame still is made up of two alternating fields, so the picture may appear blurred, but overall quality is high.

A field still is not blurred, but it has only half the information of a frame still so picture quality is lower.

**HDMI (High-Definition Multimedia Interface)**

HDMI is a next-generation digital interface for consumer electronic products. Unlike conventional connections, it transmits uncompressed digital video and audio signals on a single cable. This unit supports high-definition video output (720p, 1080p) from the HDMI AV OUT terminal. To enjoy high-definition video, a high-definition compatible television is required.

**I/P/B**

MPEG 2, the video compression standard adopted for use with DVD-Video, codes frames using these 3 picture types.

**I:** Intra coded picture

This picture has the best quality and is the best to use when adjusting the picture.

**P:** Predictive coded picture

This picture is calculated based on past I or P-pictures.

**B:** Bidirectionally-predictive coded picture

This picture is calculated by comparing past and future I and P-pictures so it has the lowest volume of information.

**JPEG (Joint Photographic Experts Group)**

This is a system used for compressing/decoding color still pictures. If you select JPEG as the storage system on digital cameras, etc., the data will be compressed to 1/10–1/100 of its original size. The benefit of JPEG is less deterioration in picture quality considering the degree of compression.

**Linear PCM (Pulse Code Modulation)**

These are uncompressed digital signals, similar to those found on CDs.

**MP3 (MPEG Audio Layer 3)**

An audio compression method that compresses audio to approximately one tenth of its size without any considerable loss of audio quality.

**Playback control (PBC)**

If a Video CD has playback control, you can select scenes and information with menus.

**Progressive/Interlaced**

The PAL video signal standard has 576 interlaced (i) scan lines, whereas progressive scanning, called 576p, uses twice the number of scan lines. For the NTSC standard, these are called 480i and 480p respectively.

Using progressive output, you can enjoy the high-resolution video recorded on media such as DVD-Video. Your television must be compatible to enjoy progressive video.

**Sampling frequency**

Sampling is the process of converting the heights of sound wave (analog signal) samples taken at set periods into digits (digital encoding).

Sampling frequency is the number of samples taken per second, so larger numbers mean more faithful reproduction of the original sound.

**WMA (Windows Media™ Audio)**

WMA is a compression format developed by Microsoft Corporation. It achieves the same sound quality as MP3 with a file size that is smaller than that of MP3.



## AMPLIFIER SECTION

### RMS Output Power: Dolby Digital Mode

Front Ch	85 W per channel (4 Ω), 1 kHz, 10 % THD
Surround Ch*	80 W per channel (4 Ω), 1 kHz, 10 % THD
Center Ch	85 W per channel (4 Ω), 1 kHz, 10 % THD
Subwoofer Ch	85 W per channel (4 Ω), 100 Hz, 10 % THD
Total RMS Dolby Digital mode power	500 W

### DIN Output Power: Dolby Digital Mode

Front Ch	50 W per channel (4 Ω), 1 kHz, 1 % THD
Surround Ch*	40 W per channel (4 Ω), 1 kHz, 1 % THD
Center Ch	50 W per channel (4 Ω), 1 kHz, 1 % THD
Subwoofer Ch	50 W per channel (4 Ω), 100 Hz, 1 % THD
Total DIN Dolby Digital mode power	280 W

\* Power output of the wireless receiver amplifier SE-FX65

## FM TUNER, TERMINALS SECTION

**Preset Memory** FM 30 stations

### Frequency Modulation (FM)

Frequency range	87.50 to 108.00 MHz (50-kHz step)
Sensitivity	1.8 μV (IHF)
S/N 26 dB	1.4 μV
Antenna terminals	75 Ω (unbalanced)

### Digital audio input

Optical digital input	Optical terminal
Sampling frequency	32 kHz, 44.1 kHz, 48 kHz

### Phone jack

Terminal	Stereo, 3.5 mm jack
----------	---------------------

### Music Port (Front)

Sensitivity	100 mV, 1.4 kΩ
Terminal	Stereo, 3.5 mm jack

## VIDEO SECTION

**Video system** PAL625/50, PAL525/60, NTSC

### Composite video output

Output level	1 Vp-p (75 Ω)
Terminal	Scart jack (1 system)

### S-video output

Y output level	1 Vp-p (75 Ω)
C output level	PAL; 0.3 Vp-p (75 Ω) NTSC; 0.286 Vp-p (75 Ω)
Terminal	Scart jack (1 system)

### Component video output

(NTSC: 480p/480i, PAL: 576p/576i)

Y output level	1 Vp-p (75 Ω)
P <sub>B</sub> output level	0.7 Vp-p (75 Ω)
P <sub>R</sub> output level	0.7 Vp-p (75 Ω)
Terminal	Pin jack (Y: green, P <sub>B</sub> : blue, P <sub>R</sub> : red) (1 system)

## RGB video output

R output level	0.7 Vp-p (75 Ω)
G output level	0.7 Vp-p (75 Ω)
B output level	0.7 Vp-p (75 Ω)
Terminal	Scart jack (1 system)

## HDMI AV output

Terminal Type A connector (19 pin)

This unit supports "HDAVI Control 2" function.

## DISC SECTION

### Discs played (8 cm or 12 cm)

- (1) DVD (DVD-Video)
- (2) DVD-RAM (DVD-VR, JPEG\*<sup>4</sup>, \*<sup>5</sup>, MP3\*<sup>2</sup>, \*<sup>5</sup>)
- (3) DVD-R (DVD-Video, DVD-VR, JPEG\*<sup>4</sup>, \*<sup>5</sup>, MP3\*<sup>2</sup>, \*<sup>5</sup>)
- (4) DVD-R DL (DVD-Video, DVD-VR)
- (5) DVD-RW (DVD-Video, DVD-VR, JPEG\*<sup>4</sup>, \*<sup>5</sup>, MP3\*<sup>2</sup>, \*<sup>5</sup>)
- (6) +R/+RW (Video)
- (7) +R DL (Video)
- (8) CD, CD-R/RW [CD-DA, Video CD, SVCD\*<sup>1</sup>, MP3\*<sup>2</sup>, \*<sup>5</sup>, WMA\*<sup>3</sup>, \*<sup>5</sup>, JPEG\*<sup>4</sup>, \*<sup>5</sup>, HighMAT Level 2 (Audio and Image)]

\*<sup>1</sup> Conforming to IEC62107

\*<sup>2</sup> MPEG-1 Layer 3, MPEG-2 Layer 3

\*<sup>3</sup> Windows Media Audio Ver.9.0 L3

Not compatible with Multiple Bit Rate (MBR)

\*<sup>4</sup> Exif Ver 2.1 JPEG Baseline files

Picture resolution: between 160x120 and 6144 x 4096 pixels (Sub sampling is 4:0:0, 4:2:0, 4:2:2 or 4:4:4). Extremely long and narrow pictures may not be displayed.

\*<sup>5</sup> The total combined maximum number of recognizable audio and picture contents and groups: 4000 audio and picture contents and 400 groups.

### Pick up

Wavelength (DVD/CD)	662/785 nm
Laser power (DVD/CD)	CLASS 1/CLASS 1M

### Audio output (Disc)

Number of channels 5.1ch (FL, FR, C, SL, SR, SW)

## USB SECTION

### USB Port

**USB Standard** USB 2.0 full speed

### Supported media file format

MP3 (\*.mp3)  
WMA (\*.wma)  
JPEG (\*.Jpg, \*.JPEG)

### USB device file system

FAT12  
FAT16  
FAT32

### USB port power

500 mA (Max)





## SPEAKER SECTION

### Front speakers SB-HF350

<b>Type</b>	1 way, 1 speaker system (Bass reflex)
<b>Speaker unit(s)</b>	Impedance 4 Ω
Full range	6.5 cm Cone type
<b>Input power (IEC)</b>	85 W* (Max)
<b>Output sound pressure</b>	80 dB/W (1.0 m)
<b>Frequency range</b>	95 Hz to 25 kHz (-16 dB) 120 Hz to 22 kHz (-10 dB)
<b>Dimensions (W x H x D)</b>	92 mm x 142 mm x 95 mm
<b>Mass</b>	0.5 kg

### Surround speakers SB-HF350

<b>Type</b>	1 way, 1 speaker system (Bass reflex)
<b>Speaker unit(s)</b>	Impedance 4 Ω
Full range	6.5 cm Cone type
<b>Input power (IEC)</b>	85 W* (Max)
<b>Output sound pressure</b>	80 dB/W (1.0 m)
<b>Frequency range</b>	95 Hz to 25 kHz (-16 dB) 120 Hz to 22 kHz (-10 dB)
<b>Dimensions (W x H x D)</b>	92 mm x 142 mm x 95 mm
<b>Mass</b>	0.5 kg

### Center speakers SB-HC350

<b>Type</b>	1 way, 1 speaker system (Bass reflex)
<b>Speaker unit(s)</b>	Impedance 4 Ω
Full range	6.5 cm Cone type
<b>Input power (IEC)</b>	85 W* (Max)
<b>Output sound pressure</b>	80 dB/W (1.0 m)
<b>Frequency range</b>	95 Hz to 25 kHz (-16 dB) 120 Hz to 22 kHz (-10 dB)
<b>Dimensions (W x H x D)</b>	140 mm x 94 mm x 95 mm
<b>Mass</b>	0.5 kg

### Subwoofer SB-HW350

<b>Type</b>	1 way, 1 speaker system (Bass reflex)
<b>Speaker unit(s)</b>	Impedance 4 Ω
Woofer	16 cm Cone type
<b>Input power (IEC)</b>	85 W (Max)
<b>Output sound pressure</b>	82 dB/W (1.0 m)
<b>Frequency range</b>	32 Hz to 220 Hz (-16 dB) 39 Hz to 180 Hz (-10 dB)
<b>Dimensions (W x H x D)</b>	153 mm x 415 mm x 257 mm
<b>Mass</b>	3.6 kg

\*Rating with low-cut filter equipped amplifier

## WIRELESS TRANSMITTER AND RECEIVER

<b>Power supply</b>	AC 230 to 240 V, 50 Hz
<b>Power consumption</b>	
Tx (SH-FX65T)	1.5 W
Rx (SE-FX65)	43 W
<b>Dimensions (W x H x D)</b>	
Tx (SH-FX65T)	65 mm x 52 mm x 8.6 mm
Rx (SE-FX65)	165 mm x 90 mm x 164 mm
<b>Mass</b>	
Tx (SH-FX65T)	0.02 kg
Rx (SE-FX65)	0.655 kg
<b>Wireless module</b>	
Frequency range	2.400 to 2.4835 GHz
No. of channels	3
<b>RMS output power</b>	
Surround Ch	80 W per channel (4 Ω), 1 kHz, 10% THD
<b>DIN output power</b>	
Surround Ch	40 W per channel (4 Ω), 1 kHz, 1% THD
<b>Total RMS power</b>	160 W
<b>Speaker Jack impedance indication</b>	3 Ω to 6 Ω
<b>Operating temperature range</b>	+5 °C to +35 °C
<b>Operating humidity range</b>	5 % to 90 % RH (no condensation)

<b>Power consumption in off mode</b>	approx. 0.3 W
--------------------------------------	---------------

## GENERAL

<b>Power supply</b>	AC 230 to 240 V, 50 Hz
<b>Power consumption</b>	
Main unit	90 W
<b>Dimensions (W x H x D)</b>	430 mm x 64.7 mm x 364.4 mm
<b>Mass</b>	Main unit 3.5 kg
<b>Operating temperature range</b>	+5 °C to +35 °C
<b>Operating humidity range</b>	5 % to 90 % RH (no condensation)

<b>Power consumption in standby mode</b>	approx. 0.8 W
--	---------------

### Note

- Specifications are subject to change without notice.  
Weight and dimensions are approximate.
- Total harmonic distortion is measured by the digital spectrum analyzer.





Manufactured under license from Dolby Laboratories.  
Dolby, Pro Logic and the double-D symbol are trademarks of Dolby Laboratories.

“DTS” and “DTS Digital Surround” are registered trademarks of DTS, Inc.

This product incorporates copyright protection technology that is protected by method claims of certain U.S. patents and other intellectual property rights owned by Macrovision Corporation and other rights owners. Use of this copyright protection technology must be authorized by Macrovision Corporation, and is intended for home and other limited viewing uses only unless otherwise authorized by Macrovision Corporation. Reverse engineering or disassembly is prohibited.

Windows Media, and the Windows logo are trademarks, or registered trademarks of Microsoft Corporation in the United States and/or other countries.

This product is protected by certain intellectual property rights of Microsoft Corporation and third parties. Use or distribution of such technology outside of this product is prohibited without a license from Microsoft or an authorized Microsoft Subsidiary and third parties.

WMA is a compression format developed by Microsoft Corporation. It achieves the same sound quality as MP3 with a file size that is smaller than that of MP3.



HighMAT™ and the HighMAT logo are either trademarks or registered trademarks of Microsoft Corporation in the United States and/or other countries.

HDMI, the HDMI logo and High-Definition Multimedia Interface are trademarks or registered trademarks of HDMI Licensing LLC.

HDAVI Control™ is a trademark of Matsushita Electric Industrial Co., Ltd.

## ■ Sales and Support Information (For the United Kingdom and Republic of Ireland)

### Customer Care Centre

- For customers within the UK: 08705 357357
- For customers within the Republic of Ireland: 01 289 8333
- Visit our website for product information
- E-mail: [customer.care@panasonic.co.uk](mailto:customer.care@panasonic.co.uk)

### Direct Sales at Panasonic UK

- Order accessory and consumable items for your product with ease and confidence by phoning our Customer Care Centre Monday-Thursday 9:00am-5:30pm, Friday 9:30am-5:30pm (Excluding public holidays).
- Or go on line through our Internet Accessory ordering application at [www.panasonic.co.uk](http://www.panasonic.co.uk).
- Most major credit and debit cards accepted.
- All enquiries transactions and distribution facilities are provided directly by Panasonic UK Ltd.
- It couldn't be simpler!
- Also available through our Internet is direct shopping for a wide range of finished products, take a browse on our website for further details.

*Interested in purchasing an extended guarantee?  
Please call 0870 240 6284 or visit our website  
[www.panasonic.co.uk/guarantee](http://www.panasonic.co.uk/guarantee).*

**Matsushita Electric Industrial Co., Ltd.**  
**Web Site:** <http://panasonic.net>



**RQTX0059-B**  
L0307NC0