



Power Systems

Hardware Management Console

models 7042-CR4, 7042-CR5, 7042-C06,
and 7042-C07 service





Power Systems

Hardware Management Console
models 7042-CR4, 7042-CR5, 7042-C06,
and 7042-C07 service

Note

Before using this information and the product it supports, read the information in “Notices,” on page 57, “Safety notices” on page v, the *IBM Systems Safety Notices* manual, G229-9054, and the *IBM Environmental Notices and User Guide*, Z125-5823.

This edition applies to IBM Power Systems™ servers that contain the POWER6™ processor and to all associated models.

© Copyright International Business Machines Corporation 2007, 2009.

US Government Users Restricted Rights – Use, duplication or disclosure restricted by GSA ADP Schedule Contract with IBM Corp.

Contents

Safety notices	v
Chapter 1. Hardware Management Console reference information	1
Identifying your HMC	1
Managed system operation	2
HMC system diagnostics	3
Power on the HMC	3
Power off the HMC	3
Power-on self-test	3
Specifications and system unit locations	3
Cable the HMC	3
External ac power cable for the HMC	3
Chapter 2. HMC diagnostics	5
Chapter 3. Removal and replacement procedures	9
Chapter 4. Hardware Management Console parts	11
Chapter 5. Cabling the HMC	23
Chapter 6. Troubleshooting the HMC	27
Correcting a <i>No connection</i> state for a managed system	27
Correcting an <i>Incomplete</i> state for a managed system	28
Correcting a <i>Recovery</i> state for a managed system	28
Recovering partition data on a managed system	29
Restoring profile data	29
Correcting an <i>Error</i> state for a managed system	30
Correcting a <i>Failed Authentication</i> state for a managed system	30
Correcting a connection problem between the HMC and a managed system	31
Resetting the managed system connection from the HMC	32
Resetting the service processor	32
HMC and system power on and power off procedures	32
Reinstalling the HMC machine code	34
Back up partition profiles	35
Restoring critical HMC data	35
Setting up the network interface as a startup device	36
Upgrading the machine code on an HMC from Version 6 to Version 7	37
Step 1. Obtain the upgrade	37
Step 2. Back up critical console information	37
Step 3. Record the current HMC configuration information	38
Step 4. Record remote command status	38
Step 5. Save upgrade data	38
Step 6. Upgrade the HMC software from Version 6 to Version 7	39
Step 7. Verify that the HMC machine code upgrade installed successfully	39
HMC problem analysis	40
Entry point for HMC problem determination	41
Beginning HMC problem determination	42
Step 1. HMC problem determination	42
Step 2. HMC problem determination	42
Step 3. HMC problem determination	42
Step 4. HMC problem determination	43
Testing the HMC	43
Testing for a power problem	43

Performing diagnostic procedures	43
Performing system unit testing using PC-Doctor	44
Testing the modem connection to the managed system	44
Testing the HMC modem connection	44
Testing the HMC Ethernet adapter.	46
Testing the HMC disk drive	47
Testing the HMC DVD-RAM drive	48
Testing the HMC diskette drive.	49
Testing the HMC display	50
Replacing an HMC	51
Verifying that your HMC DHCP private network is configured correctly	52
Backing up critical HMC data	53
Determining your HMC machine code version and release	54
Preparing for HMC configuration	54
Shutting down, logging off, and disconnecting the HMC	55
Logging off the HMC	55
Disconnecting from the HMC interface	55
Appendix. Notices	57
Trademarks	58
Electronic emission notices	58
Class A Notices	58
Terms and conditions	62

Safety notices

Safety notices may be printed throughout this guide:

- **DANGER** notices call attention to a situation that is potentially lethal or extremely hazardous to people.
- **CAUTION** notices call attention to a situation that is potentially hazardous to people because of some existing condition.
- **Attention** notices call attention to the possibility of damage to a program, device, system, or data.

World Trade safety information

Several countries require the safety information contained in product publications to be presented in their national languages. If this requirement applies to your country, a safety information booklet is included in the publications package shipped with the product. The booklet contains the safety information in your national language with references to the U.S. English source. Before using a U.S. English publication to install, operate, or service this product, you must first become familiar with the related safety information in the booklet. You should also refer to the booklet any time you do not clearly understand any safety information in the U.S. English publications.

German safety information

Das Produkt ist nicht für den Einsatz an Bildschirmarbeitsplätzen im Sinne § 2 der Bildschirmarbeitsverordnung geeignet.

Laser safety information

IBM® servers can use I/O cards or features that are fiber-optic based and that utilize lasers or LEDs.

Laser compliance

All lasers are certified in the U.S. to conform to the requirements of DHHS 21 CFR Subchapter J for class 1 laser products. Outside the U.S., they are certified to be in compliance with IEC 60825 as a class 1 laser product. Consult the label on each part for laser certification numbers and approval information.

CAUTION:

This product might contain one or more of the following devices: CD-ROM drive, DVD-ROM drive, DVD-RAM drive, or laser module, which are Class 1 laser products. Note the following information:

- **Do not remove the covers. Removing the covers of the laser product could result in exposure to hazardous laser radiation. There are no serviceable parts inside the device.**
- **Use of the controls or adjustments or performance of procedures other than those specified herein might result in hazardous radiation exposure.**

(C026)

CAUTION:

Data processing environments can contain equipment transmitting on system links with laser modules that operate at greater than Class 1 power levels. For this reason, never look into the end of an optical fiber cable or open receptacle. (C027)

CAUTION:

This product contains a Class 1M laser. Do not view directly with optical instruments. (C028)

CAUTION:

Some laser products contain an embedded Class 3A or Class 3B laser diode. Note the following information: laser radiation when open. Do not stare into the beam, do not view directly with optical instruments, and avoid direct exposure to the beam. (C030)

Power and cabling information for NEBS (Network Equipment-Building System) GR-1089-CORE

The following comments apply to the IBM servers that have been designated as conforming to NEBS (Network Equipment-Building System) GR-1089-CORE:

The equipment is suitable for installation in the following:

- Network telecommunications facilities
- Locations where the NEC (National Electrical Code) applies

The intrabuilding ports of this equipment are suitable for connection to intrabuilding or unexposed wiring or cabling only. The intrabuilding ports of this equipment *must not* be metallically connected to the interfaces that connect to the OSP (outside plant) or its wiring. These interfaces are designed for use as intrabuilding interfaces only (Type 2 or Type 4 ports as described in GR-1089-CORE) and require isolation from the exposed OSP cabling. The addition of primary protectors is not sufficient protection to connect these interfaces metallically to OSP wiring.

Note: All Ethernet cables must be shielded and grounded at both ends.

The ac-powered system does not require the use of an external surge protection device (SPD).

The dc-powered system employs an isolated DC return (DC-I) design. The DC battery return terminal *shall not* be connected to the chassis or frame ground.

Chapter 1. Hardware Management Console reference information

Learn about maintaining and servicing the Hardware Management Console (HMC).

The HMC connects to one or more managed systems to perform various functions. The HMC's primary functions include the following:

- Providing a console for system administrators and service providers to manage server hardware.
- Creating and maintaining a multiple partitioned environment on a managed system.
- Detecting, reporting, and storing changes in hardware conditions.
- Acting as a service focal point for service providers to determine an appropriate service strategy.
- Displaying operating system session terminals for each partition.

The HMC is delivered with its machine code preinstalled on the disk drive. After the system is installed and connected to a managed system, you can perform system management tasks.

The HMC machine code does not have provisions for loading or running additional applications that are not related to hardware management or service. All the tasks you need to maintain the managed system, the underlying operating system, and the HMC machine code are available by using the HMC management interface.

Identifying your HMC

This information supports HMC machine types 7042-CR4, 7042-CR5, 7042-C06, and 7042-C07.

The following illustrations identify each of the machine type 7042 models and show the cable connections located on the back of each HMC model.

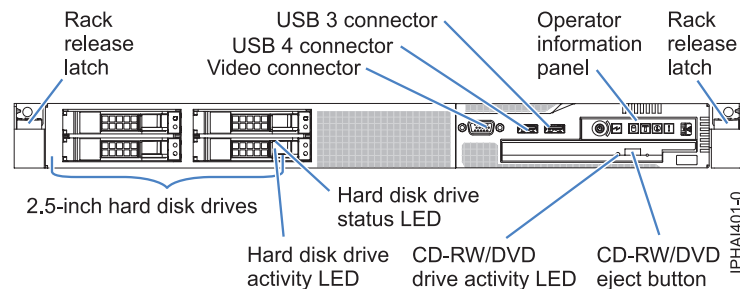

Figure 1. Model 7042-CR4 and 7042-CR5 (Front view)

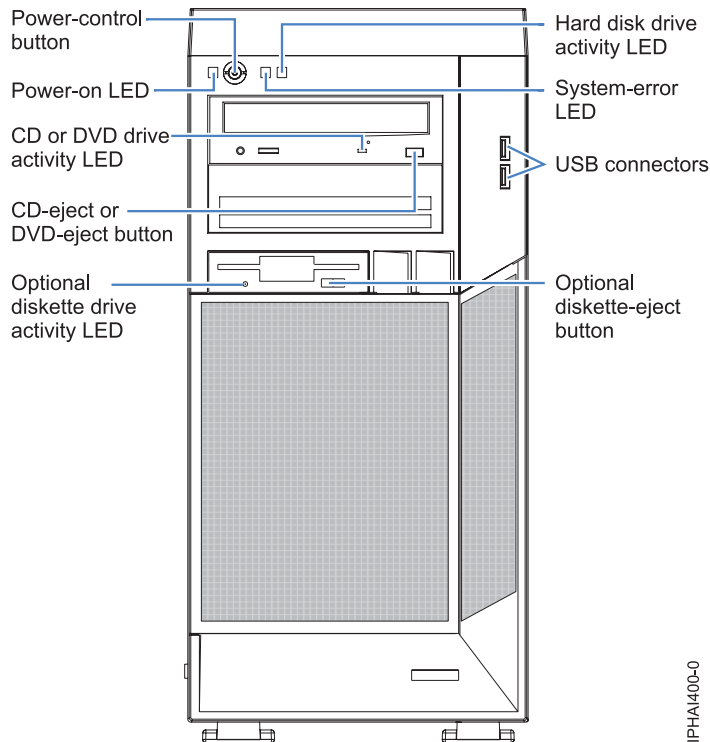

Figure 2. Model 7042-C06 and Model 7042-C07(Front view)

Managed system operation

The HMC graphical interface provides the functions needed to create and maintain a partitioned environment on a managed system. Using the interface allows for direct manipulation of HMC-defined objects and increased information regarding detected changes in hardware conditions.

The managed system can be run as a partitioned system, sometimes referred to as *logically partitioned*. This means that the managed system can run multiple operating systems simultaneously. The system can also run as a large single partition, which is known as the *manufacturing default configuration* when the system is delivered. If the system has been partitioned, then the single partition that uses all the system resources is referred to as a *full system partition*.

Partitioning provides users with the ability to divide a single managed system into several systems. Each of these systems, running in a partition, can run applications in multiple, independent environments simultaneously. Logical partitioning makes it possible for a user to run a single application using different sets of data on separate partitions, as if that application were running independently on separate physical systems. By creating partitions, for example, a company can test its programs in one partition while developing the same program in another, at the same time, all using the same system. This "same system" partitioning method is more cost-effective, potentially eliminating the need for a separate test system.

The full system partition is no different from the traditional way of using a system. The single server uses all of its resources as one system.

HMC system diagnostics

Your HMC system also provides a set of diagnostic procedures to be used when troubleshooting HMC problems. For details on accessing the HMC diagnostics, see Chapter 2, “HMC diagnostics,” on page 5.

Power on the HMC

For HMC power-on procedures, see “Power on the HMC” on page 32.

Power off the HMC

For HMC power-off procedures, see “Power off the HMC” on page 33.

Power-on self-test

To perform Power-on self-test procedures, see “Power-on self-test” on page 33.

Specifications and system unit locations

Your HMC system is based on a model of personal computer. For information about system specifications and system unit locations, use the appropriate personal computer hardware maintenance manuals. See “Equivalent maintenance information for the HMC personal computer hardware” on page 5.

Cable the HMC

For HMC power off procedures, see Chapter 5, “Cabling the HMC,” on page 23.

External ac power cable for the HMC

To avoid electrical shock, a power cable with a grounded attachment plug is provided. Use only properly grounded outlets.

Power cables used in the United States and Canada are listed by Underwriter’s Laboratories (UL) and certified by the Canadian Standards Association (CSA). These power cords consist of the following:

- Electrical cables, type ST
- Attachment plugs complying with National Electrical Manufacturers Association (NEMA) L6-30P
- Appliance couplers complying with International Electrotechnical Commission (IEC) Standard 320, Sheet C13 and C14

Power cables used in other countries consist of the following:

- Electrical cables, type HD21 or HD22
- Attachment plugs approved by the appropriate testing organization for the specific countries where they are used
- Appliance couplers complying with the International Electrotechnical Commission (IEC) Standard 320, Sheet C13 and C14

For a listing of power cables used by the HMC, see “Power cords” on page 21

For a more complete listing of HMC external cables and power cords, refer to the Site and Hardware Planning topic collection.

Chapter 2. HMC diagnostics

Learn to use the HMC diagnostics when determining the state of or capability of a component found in the HMC to perform its function(s)

If a problem is determined to be in your HMC, read, understand then perform the procedures found in the diagnostics topic.

The HMC problem analysis procedure will guide you to the appropriate repair action. Occasionally, you will be directed to the maintenance documentation for the HMC base personal computer. When this occurs, the maintenance documentation for the personal computer is used to complete the repair action.

HMC system reference code

System reference codes (SRCs) are the foundation of the hardware management consoles diagnostics.

All service request numbers (SRCs), also know as error codes, that pertain to the function of the HMC can be found in System reference codes (Cxxx-Hxxx).

System reference codes (SRCs) are the foundation of the hardware management consoles diagnostics. When All service request numbers (SRCs), also know as error codes, that pertain to the function of the HMC can be found in System reference codes (Cxxx-Hxxx).

HMC connection error codes are 6 digits in length and begin with a 0, all other HMC error codes are 8 digits in length and begin with the alphabetic characters HSC. The HMC error codes are organized in the following categories:

- 0xxxxx connection error codes
- HSCExxxx console events error codes
- HSCFxxxx Licensed Internal Code error codes
- HSCIxxxx Inventory Scout Services error codes
- HSCLxxxx error codes
- HSCPxxxx platform management error codes
- HSCSxxxx Service Focal Point™ error codes

Equivalent maintenance information for the HMC personal computer hardware

Use the information provided to help cross-reference your HMC equivalent machine type and model number for the base personal computer. You can use the entries in this table to link directly to the base PC maintenance documentation.

Table 1. Equivalent maintenance information for the HMC's personal computer hardware

HMC machine type and model number (available on the serial number plate of your HMC)	Equivalent PC server machine type and model number	Order numbers for supporting Hardware Maintenance Manuals (HMM)
7310-CR4, 7042-CR4, and 7042-CR5	7978 Model 42U or 7978 Model PBT®	41w1484
7310-C06 and 7042-C06	4362 Model 52U or 4362 Model PAT	43w6957
7042-C07	4367 Model 32U	43w7064t

For the latest information regarding maintenance of your HMC PC, system board specifications, and parts, refer to the PC hardware maintenance manuals. To obtain the latest versions of these publications through the IBM site, follow this procedure:

1. Go to the IBM  site at <http://www.ibm.com>.
2. Select **Support & downloads**.
3. Go to **Select product or service type for support** and expand the "Choose support type" box.
4. Select **System x** from the menu listing, and then select the **Go** icon.
5. On the right side of the menu, locate the "Quick path" box and type in the PC model that corresponds to your HMC, then select **Go**.
6. Select the **Troubleshooting** tab, located on the support menu.
7. In the Available topics box select **Service/Support guide**. Then click the **Go** icon.
8. Click on the link that appears below "Service/Support guide".
9. Click on the file link number listed below "File link". The file for the hardware maintenance manual will open.

Diagnostics, test, and recovery

Describes some of the diagnostic tools available for use on your HMC hardware related problems.

Choose from one of the following procedures to help in diagnosing a hardware related problem.

- Power-on self-test (POST)
 - POST beep codes
 - Error code format
- Sector disk drive scanning procedure
 - To do a scan of your HMC disk drive, do the following:
 1. Power off the HMC.
 2. Power on the HMC.
 3. As the HMC is rebooting, watch the HMC display. After the second BroadCom Ethernet driver screen is displayed, simultaneously press the "CTRL" key and the letter "A" key.
 4. From the list of options, select **Disk Utilities**.
 5. Select **Verify Disk Media...** The HMC will perform a scan of your disk drive.
- PC-Doctor

Note: For additional information about items in the previous list, see the appropriate personal computer hardware maintenance manual. To access the personal computer hardware maintenance documentation, refer to the "Equivalent maintenance information for the HMC personal computer hardware" on page 5.

PC-Doctor

PC-Doctor is a set of diagnostic and system information tools included with the HMC. In rack-mounted HMC models, PC-Doctor is preinstalled on the system. PC-Doctor is included on the HMC Recovery CDs for Version 3.0 Release 3 (or later) for HMC models that are not rack-mounted.

Note:

- ISO image support is available on CD-ROM for the PC models 8485, 4362 and the HMC models 7xxx-C05 and 7xxx-C06 or at the following site: <http://www.ibm.com>.
- ISO image support is available on diskettes or CD-ROM for the PC models 8305, 8187, 8141 and the HMC models 7xxx-C03 and 7xxx-C04 HMCs or at the following site: <http://www.lenovo.com>

Running PC-Doctor on an HMC that is not rack-mounted

Before accessing the PC-Doctor application on the HMC, create a bootable diskette (referred to as the PC-Doctor diskette in this topic).

To create the diskette:

1. Insert volume 2 of HMC Recovery CD into the CD drive.
2. Select **Start > My Computer**.
3. Open the CD and go to the pc_diag directory.
4. Open the readme file and follow the instructions for creating the PC-Doctor diskette using the pc_diag.exe tool.

To run PC-Doctor:

1. Power off the HMC.
2. Insert the PC-Doctor diskette that you created.
3. Power on the HMC.

If the HMC does not read the PC-Doctor diskette upon startup, the problem might be due to the startup sequence. To make the PC-Doctor diskette the primary startup media, do the following:

1. Power off the HMC.
2. Power on the HMC and when the Setup Utility prompts during startup, press F1.
3. Select the **Startup** tab.
4. Highlight **Startup Sequence** and press Enter.
5. Under **Primary Startup Sequence**, make sure the first startup device is set to **Removable**. Then follow the remainder of the instructions on the screen to complete the procedure.

Running PC-Doctor on a rack-mounted HMC

Teaches you how to run PC-Doctor from your rack-mounted HMC.

Note:

- A rack-mounted HMC has PC-Doctor preinstalled in read only memory (ROM). The diagnostics are run from ROM, there is no boot media required.
- If you are directed by a your service provider, you can obtain and install updated versions of PC-Doctor.
 - The updates for PC model 7978 and HMC 7xxx-CR4 can be obtained from diskette, CD-ROM, or going to site <http://www.ibm.com>.
 - The updates for PC models 8837, 8676 and HMC models 7xxx-CR3, and 7xxx-CR2 can be obtained from diskettes, or going to site <http://www.ibm.com>.

To run PC-Doctor on a rack-mounted HMC:

1. Turn off the power to the HMC.
2. Turn on the power to the HMC and press F2 when the message F2 for Diagnostics is displayed, press F2.
3. If prompted, type the appropriate password, then press Enter.
4. Select either **Extended** or **Basic** from the top of the screen.
5. From the diagnostic screen, select the test you want to run from the list and then follow all instructions.

Note: For additional information about HMC diagnostics, go to the diagnostics section in the appropriate personal computer hardware maintenance manual. To access the personal computer hardware maintenance documentation, refer to “Equivalent maintenance information for the HMC personal computer hardware” on page 5.

Connector and hard disk drive restrictions for the HMC

Identifies the connector and disk drive restriction found on your HMC.

Models 7310-C05 and 7042-C05 have the following two hard disk drive restrictions:

- Use of the parallel port

Note: The HMC is a closed system and as such, the hardware is used in a limited manner. No device drivers or code support any peripheral devices that use a parallel port.

- Use of more than one hard disk drive

To view the location of each HMC connector, refer to Chapter 5, “Cabling the HMC,” on page 23

Chapter 3. Removal and replacement procedures

Select and then perform the part removal and replacement procedures for the personal computer on which your HMC is based.

Depending on the system configuration, when you are directed to exchange parts, run tests, or change configuration data, the interface to the managed systems will be unavailable. If possible, before starting any of these tasks, ensure that all system management tasks are completed and all critical data is backed up.

Attention:

- Removing power from an HMC might cause loss of data on the disk drives. If power must be removed, select Power Off from the HMC user interface. This action shuts down the operating system and turns off the power to the HMC. See “HMC and system power on and power off procedures” on page 32 before proceeding with any of the removal procedures.
- The system board, adapters, memory modules, and processor modules can be damaged by electrostatic discharge. If you are directed to exchange FRUs in a HMC, refer to the “Handling Electro-Static Discharge (ESD) Sensitive Devices ” in the appropriate PC maintenance information manuals.

When you are referred to the hardware maintenance manual for the personal computer, use the hardware maintenance manual for the appropriate personal computer machine type. To find documentation about the base HMC personal computer and its components, see “Equivalent maintenance information for the HMC’s personal computer hardware”

Equivalent maintenance information for the HMC’s personal computer hardware

The following table provides information to help cross-reference your HMC equivalent machine type and model number for the base personal computer. You can use the entries in this table to link directly to the base PC maintenance documentation.

Table 2. Equivalent maintenance information for the HMC’s personal computer hardware

HMC machine type and model number (available on the serial number plate of your HMC)	Equivalent PC server machine type and model number	Order numbers for supporting Hardware Maintenance Manuals (HMM)
7310-CR4 and 7042-CR4	7978 Model 42U or 7978 Model PBT	41w1484
7310-C06 and 7042-C06	4362 Model 52U or 4362 Model PAT	43w6957
7042-C07	4367 Model 32U	43w7064t

For the latest information regarding maintenance of your HMC PC, system board specifications, and parts, refer to the PC hardware maintenance manuals. To obtain the latest versions of these publications through the IBM site, follow this procedure:

1. Go to the IBM  site at <http://www.ibm.com>.
2. Select **Support & downloads**.
3. Go to **Select product or service type for support** and expand the “Choose support type” box.
4. Select **System x** from the menu listing, and then select the **Go** icon.
5. On the right side of the menu, locate the “Quick path” box and type in the PC model that corresponds to your HMC, then select **Go**.
6. Select the **Troubleshooting** tab, located on the support menu.
7. In the Available topics box select **Service/Support guide**. Then click the **Go** icon.
8. Click on the link that appears below “Service/Support guide”.

9. Click on the file link number listed below "File link". The file for the hardware maintenance manual will open.

Recovering the HMC

If the HMC has had a problem and you need to recover the HMC, see "Reinstalling the HMC machine code" on page 34.

Attention: This procedure will restore the HMC image onto the disk drive in the HMC personal computer. Before performing this procedure, contact HMC support and also ensure that there are backups for all critical console data.

Backing up partition profiles

Ensure that critical data that is stored on the HMC is also regularly maintained on backup media.

To back up partition profiles, see "Back up partition profiles" on page 35.

HMC machine code updates

For information about updates or upgrades for the HMC machine code, refer to "Upgrading the machine code on an HMC from Version 6 to Version 7" on page 37.

Recovering an HMC after replacing a disk drive

If you have to replace a disk drive, you must recover the HMC image and restore your stored profile data. Go to "Reinstalling the HMC machine code" on page 34 for more information.

Performing the firmware (BIOS/VPD) update procedure (after replacing the system board)

When you replace the system board, perform the firmware update procedure for your HMC personal computer.

Attention: Refer to the information label located inside the system unit cover for any model-specific information.

To perform the firmware (BIOS/VPD) update procedure, perform the following steps:

1. To find documentation about the base HMC personal computer and its components, see "Equivalent maintenance information for the HMC's personal computer hardware" on page 9.
2. Review the section in your HMC personal computer information for "Updating the firmware."
3. Perform the procedures to update the new system board with the latest BIOS firmware.
4. Perform the procedures to update the vital product data (VPD) information with the machine type, model, and serial number for the HMC.
5. Return the HMC to normal operations.

Chapter 4. Hardware Management Console parts

Contains illustrations, part descriptions and part numbers that are used when ordering replacement parts for your Hardware Management Console (HMC).

Personal computer parts

Contains part number information for parts used in assembling your HMC.

Note: FRU parts and part numbers are subject to update due to our parts system substitution-update policy. With our parts system substitution-update policy we make every effort to supply you with the latest components available for your model HMC.

The following table contains a cross-reference equivalent of the HMC machine type and model number to the personal computer machine type and model number. For personal computer parts information not listed in the following tables, refer to the hardware maintenance manual for your personal computer.

Table 3. Equivalent maintenance information for the HMC's personal computer hardware

HMC machine type and model number (available on the serial number plate of your HMC)	Equivalent PC server machine type and model number	Order numbers for supporting Hardware Maintenance Manuals (HMM)
7310-CR4, 7042-CR4 and 7042-CR5	7978 Model 42U or 7978 Model PBT	41w1484
7310-C06 and 7042-C06	4362 Model 52U or 4362 Model PAT	43w6957
7042-C07	4367 Model 32U	43w7064t

For the latest information regarding maintenance of your HMC PC, system board specifications, and parts, refer to the PC hardware maintenance manuals. To obtain the latest versions of these publications through the IBM site, follow this procedure:

1. Go to the IBM  site at <http://www.ibm.com>.
2. Select **Support & downloads**.
3. Go to **Select product or service type for support** and expand the "Choose support type" box.
4. Select **System x** from the menu listing, and then select the **Go** icon.
5. On the right side of the menu, locate the "Quick path" box and type in the PC model that corresponds to your HMC, then select **Go**.
6. Select the **Troubleshooting** tab, located on the support menu.
7. In the Available topics box select **Service/Support guide**. Then click the **Go** icon.
8. Click on the link that appears below "Service/Support guide".
9. Click on the file link number listed below "File link". The file for the hardware maintenance manual will open.

7310-CR4, 7042-CR4, and 7042-CR5 parts

Models 7310-CR4, 7042-CR4, and 7042-CR5 use a personal computer machine type of 7978 Model 42U for its base configuration. To access the personal computer hardware maintenance manuals, see "Personal computer parts."

Note: Each PC hardware maintenance manual may reference more than one machine type in its title. If necessary, to cross-reference to the original PC hardware maintenance manual, make sure that you find the hardware maintenance manual for the PC machine type and model for the HMC that you are servicing.

The following illustration and table identifies the major components that make up the Models 7310-CR4, 7042-CR4, and 7042-CR5.

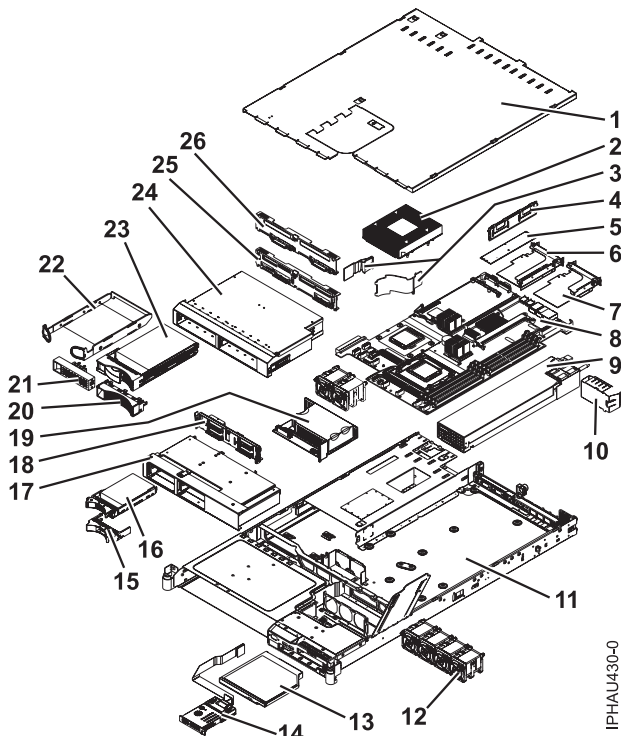

Figure 3. Models 7310-CR4, 7042-CR4, and 7042-CR5 parts illustration

Notes:

1. Field replaceable units (FRUs) must be serviced only by an authorized service provider.
2. Customer replaceable units (CRUs) can be replaced by the customer. The CRUs are defined as either Tier 1 or Tier 2 as follows:

Tier 1 CRU

Procedure that a customer can perform without input from a service provider. The procedure used to service this type of component is usually required to be done by the customer.

Tier 2 CRU

Procedure that a customer can perform, but may require support from a service provider. The procedure used to service this component is usually not required to be done by the customer.

3. If the part you are replacing is not identified as being either Tier 1 or Tier 2, call your service provider to service the FRU.

Table 4. 7310-CR4, 7042-CR4, and 7042-CR5 Parts listing

Index	Description	Tier 1 CRUs	Tier 2 CRUs	Part number
1	Top cover assembly	*		43W0609
2	Heat sink assembly			39Y9423
3	Air baffles	*		39Y9420
4	Memory, 512 MB ECC DRR	*		39M5781
5	Not applicable to this model			
6	PCI-X riser card		*	39Y6975

Table 4. 7310-CR4, 7042-CR4, and 7042-CR5 Parts listing (continued)

Index	Description	Tier 1 CRUs	Tier 2 CRUs	Part number
7	Not applicable to this model			
8	Planar, SATA			42D3639
9	Power supply, 670 W	*		39Y7189
10	Power supply filler panel	*		XXXXXXX
11	Chassis assembly			39Y9522
12	Fan assembly unit (dual fans)	*		26K8083
13	DVD-RAM Drive	*		42C0955
14	Operator information panel card assembly			39K6973
15	Not applicable to this model			
16	Not applicable to this model			
17	Not applicable to this model			
18	Not applicable to this model			
19	Power backplane		*	39Y6972

Table 5. 7310-CR4, 7042-CR4, and 7042-CR5 Parts listing (continued)

Index	Description	Units		Part number
20	Not applicable to this model			
21	Simple-swap filler panel, 3.5 inch	*		23K4990
22	Disk drive, 80 GB SATA	*		39M4503
23	Not applicable to this model			
24	Simple-swap SATA disk drive cage		*	32R2823
25	Not applicable for this model			
26	Power cable, SATA, with backplate	*		26K8060
	Microprocessor, 2.0 GHz with heat sink (Used on 43W5900 Planar)			42C4229
	Microprocessor, 2.5 GHz 4 core (Used on 46M7149 Planar)			44R5646
	Media bezel assembly	*		39Y9419
	Rack latch assembly, EIA		*	26K8080
	Service label, 3.5 inch, SATA	*		32R2820
	Service label, right fan door	*		39Y9418
	USB connector cable, front panel (field replaceable unit)		*	26K8058
	CD-RW/DVD drive interposer card		*	42C3983
	Slides and hardware		*	52P8517
	Battery, system board, 3.0 V	*		33F8354
	Mouse, (Black)	*		03N6669
	Modem cable (see "HMC modem cable part numbers" on page 19)			

7310-C06 and 7042-C06 parts

Machine type 7310-C06 and 7042-C06 use a personal computer machine type of 4362-52U for its base configuration. To access the personal computer hardware maintenance manuals, see “Personal computer parts” on page 11.

Note: Each PC hardware maintenance manual may reference more than one machine type in its title. If necessary, to cross-reference to the original PC hardware maintenance manual, make sure that you find the hardware maintenance manual for the PC machine type and model for the HMC that you are servicing.

The following illustration and table identifies the major components that make up the Models 7310-C06 and 7042-C06.

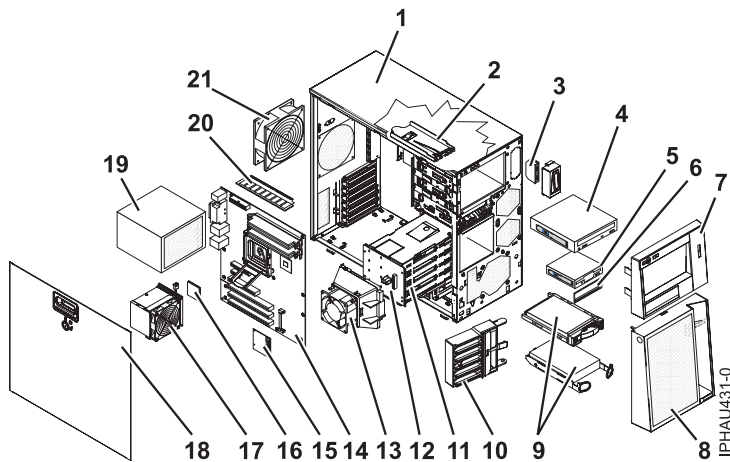

Figure 4. Models 7310-C06 and 7042-C06 parts illustration

Notes:

1. Field replaceable units (FRUs) must be serviced only by an authorized service provider.
2. Customer replaceable units (CRUs) can be replaced by the customer. A definition of Tier 1 and Tier 2 CRUs for this model HMC is:

Tier 1 CRU

Uses a procedure that a customer can perform without input from a service provider. The procedure used to service this type of component is usually required to be done by the customer.

Tier 2 CRU

Uses a procedure that a customer can perform, but may require support from a service provider. The procedure used to service this component is usually not required to be done by the customer.

3. If the part you are replacing is not identified as being either Tier 1 or Tier 2, call your service provider to service the FRU.

Table 6. 7310-C06 and 7042-C06 parts listing

Index	Description	Tier 1 CRU	Tier 2 CRU	Part number
1	Chassis assembly, non-redundant power supply			42C8916
2	Front-panel assembly		*	25R8865
3	Front USB connector assembly (cable)		*	26K7340

Table 6. 7310-C06 and 7042-C06 parts listing (continued)

Index	Description	Tier 1 CRU	Tier 2 CRU	Part number
4	DVD-RAM drive	*		39M3565
5	Diskette drive	*		33P3343
6	Diskette drive bezel	*		25R8857
7	Bezel, upper	*		42C8912
8	Bezel, lower	*		42C8913
9	Hard disk drive, SATA, 80 GB simple swap	*		39M3701
	Disk drive tray	*		25R8864
	Half -Height disk drive, slim bare Rambo-5	*		42C0957
10	Retention bracket, PCI		*	13N2993
11	Hard disk drive cage, 3.5-inch	*		42C8910
12	Disk drive backplane (for 3.5 inch simple-swap SATA disk drives)		*	25R8842
13	3.5 inch disk drive air-duct assembly		*	39Y9860
14	System board assembly			43W4982
15	SAS/SATA controller		*	42C1279
16	Microprocessor, 2.13 GHz			41Y3849
17	Fan-sync			43W0401
18	Side cover with lock	*		25R8859
19	Power supply, 400 watt			39Y7297
20	Memory, 512MB	*		41Y2725
21	System fan, rear		*	25R8829
	PSU adapter bracket (not shown)		*	42C7509

7310-C06 parts listed in the following table are not illustrated.

Table 7. 7310-C06 and 7042-C06 parts listing (continued)

Description	Tier 1 CRU	Tier 2 CRU	Part number
3.0 V battery		*	33F8354
Bezel kit	*		13N2450
Cable, 24-inch SATA signal		*	25R5635
Cable, 400 watt DAS		*	25R8849
Shield kit	*		13N2997
Service label			43W0417
Cable, panel mount		*	13N2413
Cable, diskette drive		*	39R8112
Cable, IDE signal		*	13N2466
Cable, serial port 2	*		42C1053
EMC I/O shield	*		43W4986
EMC shield kit	*		13N2997
Mouse, 2-button	*		03N6669

Table 7. 7310-C06 and 7042-C06 parts listing (continued) (continued)

Description	Tier 1 CRU	Tier 2 CRU	Part number
Kit, shield	*		13N2997
Kit, bezel	*		13N2450
Retainer kit (for optical and diskette drives)	*		39R9369
Retention module, fan sync			25R8873
Stabilizing feet	*		13N2985
C2 switch		*	39Y9783
Miscellaneous Kit (clip, insulator, retainer)	*		39Y9773
Modem cable (see "HMC modem cable part numbers" on page 19)			

7042-C07 parts

Machine type 7042-C07 use a personal computer machine type of 4367-32U for its base configuration. To access the personal computer hardware maintenance manuals, see "Personal computer parts" on page 11.

Note: Each PC hardware maintenance manual may reference more than one machine type in its title. If necessary, to cross-reference to the original PC hardware maintenance manual, make sure that you find the hardware maintenance manual for the PC machine type and model for the HMC that you are servicing.

The following illustration and table identifies the major components that make up the Model 7042-C07.

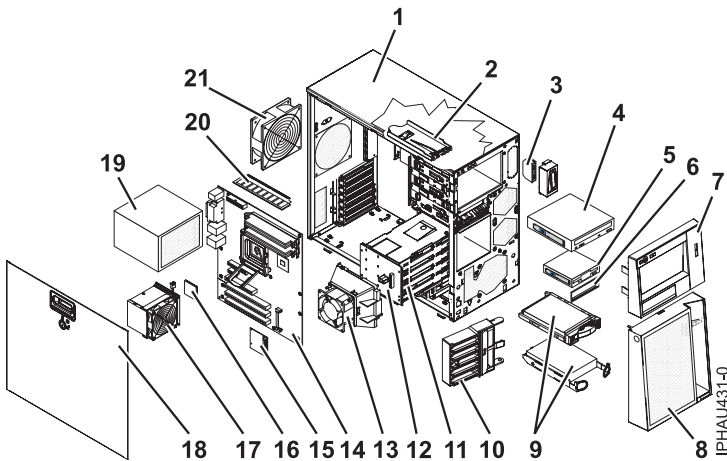

Figure 5. Model 7042-C07 parts illustration

Notes:

1. Field replaceable units (FRUs) must be serviced only by an authorized service provider.
2. Customer replaceable units (CRUs) can be replaced by the customer. A definition of Tier 1 and Tier 2 CRUs for this model HMC is:

Tier 1 CRU

Uses a procedure that a customer can perform without input from a service provider. The procedure used to service this type of component is usually required to be done by the customer.

Tier 2 CRU

Uses a procedure that a customer can perform, but may require support from a service provider. The procedure used to service this component is usually not required to be done by the customer.

- If the part you are replacing is not identified as being either Tier 1 or Tier 2, call your service provider to service the FRU.

Table 8. 7042-C07 parts listing

Index	Description	Tier 1 CRU	Tier 2 CRU	Part number
1	Chassis assembly, non-redundant power supply, (without diskette drive)			44X0386
2	Control panel assembly		*	44E7571
3	Dual USB connector assembly (cable)		*	26K7340
4	Half Height DVD-RAM drive	*		43W8467
5	Diskette drive (Shown in drawing but not available on the 7042-C07)	*		N/A
6	Diskette drive bezel (Shown in drawing but not available on the 7042-C07)	*		N/A
7	Bezel assembly, upper front	*		42C7290
8	Bezel assembly, lower front	*		42C7293
9	Hard disk drive, 250 GB SATA, simple swap with tray	*		39M4511
	Simple Swap disk drive tray	*		25R8864
10	Retention bracket, PCI, (front)		*	13N2993
	EMI shield bracket assembly			44E7337
11	Hard disk drive cage, 3.5-inch	*		42C8910
	Hard disk drive shield for HDD cage			44X0388
12	Disk drive backplane (for 3.5 inch simple-swap SATA disk drives)		*	25R8842
	EULER 2.5 Hard disk drive backplane (SATA simple swap)			25R8842
	Hard disk drive carrier assembly	*		42C7495
13	3.5 inch disk drive air-duct assembly		*	39Y9860
14	System board assembly			43W7312
15	SAS/SATA controller		*	43V7415
16	Microprocessor, 3.0 GHz dual core, 1333 MHz			44E7588
17	Fan-sink (heatsink)			43W0401
18	Side cover	*		25R8836
	Side cover with lock	*		25R8859
19	Power supply, 401 watt			39Y7330
20	Memory, 512MB	*		41Y2725
21	System fan, rear		*	25R8829
	PSU adapter bracket (not shown)		*	42C7509

7042-C07 parts listed in the following table are not illustrated.

Table 9. 7042-C07 parts listing (continued)

Description	Tier 1 CRU	Tier 2 CRU	Part number
3.0 V battery		*	33F8354
Bezel kit	*		13N2450
Cable, 18-inch SATA signal		*	39Y9810
Cable, 401 watt DAS		*	25R8849
EMC shield kit	*		13N2997
EMC I/O shield	*		25R8843
System service label	*		44E7281
Keylock, keyed-random		*	26K7364
Cable, panel mount assembly, SATA		*	13N2413
Cable, IDE signal		*	13N2466
Cable, serial port 2	*		42C1053
EMC shield kit	*		13N2997
PCI-X SCSI Enablement Card	*		44E4851
Mouse, 2-button	*		03N6669
Kit, bezel	*		13N2450
Support and hold down brackets	*		41Y9086
Retainer kit (for optical and diskette drives)	*		39R9369
Retention module, fan sync			25R8873
Stabilizing feet	*		13N2985
C2 switch		*	39Y9783
Miscellaneous tray kit (clip, insulator, retainer)	*		39Y9773
Modem cable (see "HMC modem cable part numbers" on page 19)			

For a more complete listing of external cabling and power cords for the HMC, refer to the Site and Hardware Planning topic collection.

HMC keyboard CRUs

The keyboards identified in the following table can be attached to any HMC.

Notes:

1. All keyboards are considered a Tier 1 CRU.
2. You must have the specific character set designed for each language installed on your HMC.

Keyboard country code	FRU/CRU part number
U.S. English	10N6956
Arabic	10N6984
Belgian/French	89P8302
Belgian/U.K.	10N6969
Bulgarian	10N6972

Keyboard country code	FRU/CRU part number
Brazilian Portuguese	10N6963
Chinese/U.S.	10N6966
Czech	10N6981
Danish	10N6971
Dutch	10N6975
English/EMEA	10N6988
French	10N6957
French Canadian 445	10N6967
French Canadian 58	10N6968
German	10N6959
Greek	10N6977
Hebrew	10N6978
Hungarian	10N6964
Icelandic	89P8317
Italian 141	89P8318
Italian 142	10N6958
Japanese 194	10N6962
Korean	10N6965
LA Spanish	10N6983
Norwegian	10N6974
Polish	10N6979
Portuguese	10N6976
Romanian	89P8326
Russian	10N6986
Russian/Cyrillic	89P8328
Serbian/Cyrillic	89P8329
Slovak	10N6980
Spanish	10N6961
Swedish/Finnish	10N6870
Swiss/French/German	10N6973
Thailand	89P8334
Turkish 440	10N6982
Turkish 179	89P8336
U.K. English	10N6960
U.S.	89P8338
Yugoslav/Latin	89P8339

HMC modem cable part numbers

The following tables contain part number information for HMC modem cables, along with the name of the country or region where used, and a listing of countries along with the telephone cable name and part number where used.

If you are using a cable other than one of the cables listed in the following table, read the following caution statement.

Note: For a more complete listing of external cabling and power cords for the HMC, refer to the Site and Hardware Planning topic collection.

CAUTION:

To reduce the risk of fire, use only No. 26 AWG or larger (for example, 24 AWG) UL-listed or CSA certified telecommunication line cord. (C035)

Primary country or region	Cable name	Cable part number
Austria	AUS	21H4902
Australia	AUZ	75G3807
Belgium	BEL	21H4903
Denmark	DN	75G3812
Finland	FN	75G3809
France	FR	75G3803
Germany	GE	75G3804
Hong Kong (S.A.R.)	HK	75G3808
Israel	ISR	21H4905
Italy	IT	75G3802
Netherlands	NL	75G3810
South Africa	SAF	21H4904
Sweden	SW	75G3806
Switzerland	SZ	75G3811
United Kingdom	UK	75G3805
United States	US	87G6236

External modems

Contains a list of external modem part number along with the primary country or region where used.

Primary country or region	Modem part number
United States	03N7035
Australia	03N7036
Europe	03N7037
United Kingdom	03N7038
China	03N7039
Taiwan	03N7040
All geographies	03N7041
	10N8499

Internal modem

When ordering a replacement internal modem for your HMC, use part number 10N8499.

Power cords

The manufacturer provides a power cord with a grounded attachment plug to use with this product. To avoid electrical shock, always use the power cord and plug with a properly grounded outlet.

Power cords used in the United States and Canada are listed by Underwriter’s Laboratories (UL) and certified by the Canadian Standards Association (CSA).

- For units intended to be operated at 115 volts: Use a UL-listed and CSA-certified cord set consisting of a minimum 18 AWG, Type SVT or SJT, three-conductor cord, a maximum of 15 feet in length and a parallel blade, grounding-type attachment plug rated 15 amperes, 125 volts.
- For units intended to be operated at 230 volts (within the U.S.): Use a UL-listed and CSA-certified cord set consisting of a minimum 18 AWG, Type SVT or SJT, three-conductor cord, a maximum of 15 feet in length and a tandem blade, grounding-type attachment plug rated 15 amperes, 250 volts.
- For units intended to be operated at 230 volts (outside the U.S.): Use a cord set with a grounding-type attachment plug. The cord set should have the appropriate safety approvals for the country in which the equipment will be installed.
- The power cords listed in the following table are specifically designed for a country or region and are usually available only in that country or region.

Note: All power cords are considered a Tier 1 CRU.

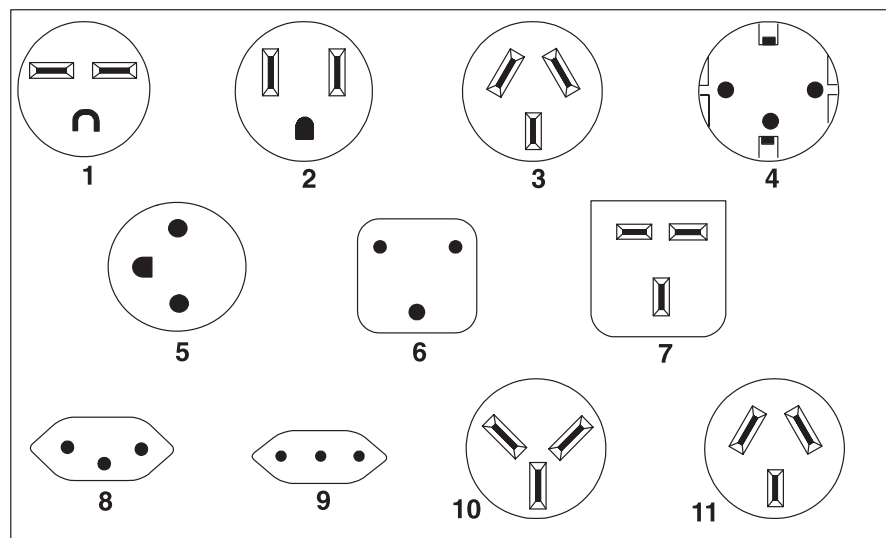

Index	Power cord part number	Used in these countries and regions
1	1838574	Thailand, Bahamas, Barbados, Bolivia, Brazil, Canada, Costa Rica, Dominican Republic, Ecuador, El Salvador, Guatemala, Guyana, Haiti, Honduras, Jamaica, Japan, Netherlands Antilles, Panama, Peru, Philippines, Taiwan, Trinidad (West Indies), Tobago, United States of America, Venezuela
2	6952301	Bahamas, Barbados, Bermuda, Bolivia, Brazil, Canada, Cayman Islands, Colombia, Costa Rica, Dominican Republic, Ecuador, El Salvador, Guatemala, Guyana, Haiti, Honduras, Jamaica, Japan, Korea (South), Liberia, Mexico, Netherlands Antilles, Nicaragua, Panama, Peru, Philippines, Saudi Arabia, Suriname, Taiwan, Trinidad (West Indies), United States of America, Venezuela

Index	Power cord part number	Used in these countries and regions
3	13F9940	Argentina, Australia, China (PRC), New Zealand, Papua New Guinea, Paraguay, Uruguay, Western Samoa
4	13F9979	Afghanistan, Algeria, Andorra, Angola, Austria, Belgium, Benin, Bulgaria, Burkina Faso, Burundi, Cameroon, Central African Rep., Chad, China (Macau S.A.R.), Czech Republic, Egypt, Finland, France, French Guiana, Germany, Greece, Guinea, Hungary, Iceland, Indonesia, Iran, Ivory Coast, Jordan, Lebanon, Luxembourg, Malagasy, Mali, Martinique, Mauritania, Mauritius, Monaco, Morocco, Mozambique, Netherlands, New Caledonia, Niger, Norway, Poland, Portugal, Romania, Senegal, Slovakia, Spain, Sudan, Sweden, Syria, Togo, Tunisia, Turkey, former USSR, Vietnam, former Yugoslavia, Zaire, Zimbabwe
5	13F9997	Denmark
6	14F0015	Bangladesh, Burma, Pakistan, South Africa, Sri Lanka
7	14F0033	Antigua, Bahrain, Brunei, Channel Islands, China (Hong Kong S.A.R.), Cyprus, Dubai, Fiji, Ghana, India, Iraq, Ireland, Kenya, Kuwait, Malawi, Malaysia, Malta, Nepal, Nigeria, Polynesia, Qatar, Sierra Leone, Singapore, Tanzania, Uganda, United Kingdom, Yemen, Zambia
8	14F0051	Liechtenstein, Switzerland
9	14F0069	Chile, Ethiopia, Italy, Libya, Somalia
10	14F0087	Israel

Chapter 5. Cabling the HMC

Connect the Hardware Management Console (HMC) cables, connect the Ethernet cable, and connect the HMC to a power source.

If the physical HMC is not located within 8 meters (25 feet) away from the managed system, you must supply a separate system that can access the Internet using a browser. This system must be within 8 meters (25 feet) of the managed system. This setup allows service personnel remote access to the HMC. The HMC must also be configured to allow for this remote access.

DANGER

Electrical voltage and current from power, telephone, and communication cables are hazardous.

To avoid a shock hazard:

- Do not connect or disconnect any cables or perform installation, maintenance, or reconfiguration of this product during an electrical storm.
- Connect all power cords to a properly wired and grounded electrical outlet. Ensure outlet supplies proper voltage and phase rotation according to the system rating plate.
- Connect any equipment that will be attached to this product to properly wired outlets.
- When possible, use one hand only to connect or disconnect signal cables.
- Never turn on any equipment when there is evidence of fire, water, or structural damage.
- Disconnect the attached power cords, telecommunications systems, networks, and modems before you open the device covers, unless instructed otherwise in the installation and configuration procedures.
- Connect and disconnect cables as described below when installing, moving, or opening covers on this product or attached devices.

To Disconnect:

1. Turn everything OFF (unless instructed otherwise).
2. Remove power cords from the outlet.
3. Remove signal cables from connectors.
4. Remove all cables from devices.

To Connect:

1. Turn everything OFF (unless instructed otherwise)
2. Attach all cables to devices.
3. Attach signal cables to connectors.
4. Attach power cords to outlet.
5. Turn device ON.

(D005)

Use the following instructions to help you cable your rack-mounted or stand-alone HMC.

Attention: *Do not* plug the power cords into the electrical outlet until you are instructed to do so.

1. Ensure that you position the HMC in the correct location.
2. Choose from the following options:
 - If you are installing a rack-mounted HMC, continue with step 3 on page 24.

- If you are installing a stand-alone HMC, continue with step 4.
3. Perform the following steps to install the cables on a rack-mounted HMC:
 - a. Use the following illustration to identify the location of the connectors described in these instructions:

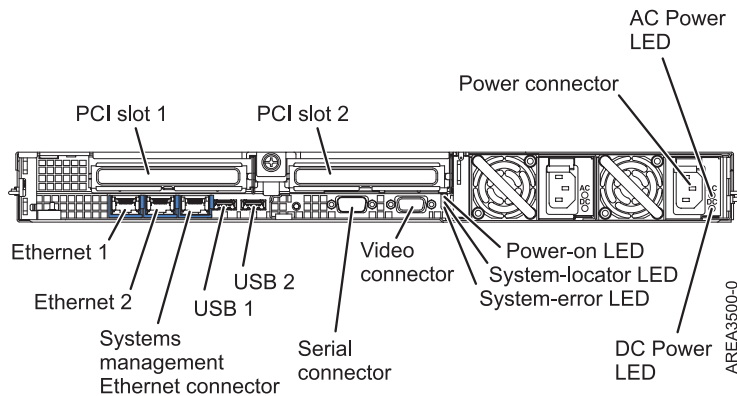

Figure 6. Back view of a typical rack-mounted HMC

- b. If you are installing your HMC into a rack, see the Installing and configuring the Hardware Management Console topic collection. When you are finished installing the HMC into a rack, continue with the next step.
 - c. Connect the keyboard, display, and mouse using the USB conversion option cable.
 - d. Continue with step 5 on page 25.
4. If you are installing a stand-alone HMC, perform the following steps:
 - a. Use the following illustration to identify the location of the connectors described in these instructions:

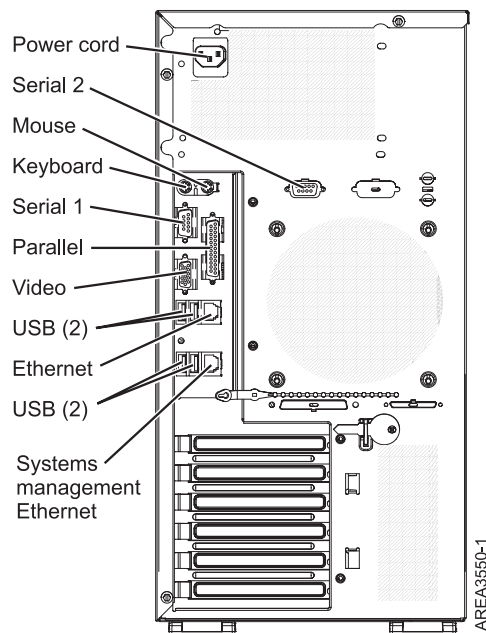

Figure 7. Back view of a typical stand-alone (tower) HMC

Table 10. Supported HMC ports

Port	Description
Video	The Video port is used as monitor connection.
PS/2 Keyboard/Mouse	A PS/2 keyboard or mouse is not included with the HMC, but you can attach either.
Serial 1	Serial 1 is supported for an external modem.
USB	These ports are supported for a USB keyboard, mouse, flash memory, or USB diskette drive.
Ethernet	The Ethernet port is used as the HMC's primary network connection.

The HMC does not support the use of parallel, Serial 2, or systems management Ethernet ports.

- b. Attach the monitor cable to the monitor connector, and tighten the screws.
 - c. Attach the power cord to the monitor.
 - d. Ensure that the voltage selection switch on the HMC is set to the voltage used in your world region. The voltage selection switch is red and is located near the power connector. Move the switch so that the voltage used in your world region is displayed.
 - e. Plug the power cord into the HMC.
 - f. Connect the keyboard and mouse to the Universal Serial Bus (USB) ports on the HMC. You can connect the keyboard and mouse to the USB ports on the front or back panels.
5. Connect the modem:

Note: During the installation and configuration of the HMC, the modem might automatically dial out as the HMC follows routine call-out procedures. This is usual behavior.

If you are connecting an external modem, do the following:

- a. Optional: Install the external modem into a rack.
- b. If you have not already done so, connect the modem data cable to the external HMC modem.
- c. Connect the modem data cable to the system port on the HMC labeled with the following symbol:

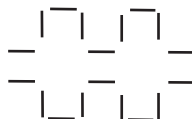

IPHA1522-0

- d. Use the telephone cable to connect the line port of the external modem to the analog telephone jack on your wall.

If you are connecting to an integrated modem, use the data cable to connect the integrated HMC modem to the appropriate data source. For example, use the telephone cable to connect the HMC modem line port to the analog jack on your wall.

6. Connect the Ethernet (or crossover) cable from the HMC to the managed server.

Note:

- In general, connect your HMC to the managed server in a private service DHCP network. If you have not installed any additional Ethernet adapters in the PCI slots on your HMC, use the primary integrated Ethernet port. Use the previous illustrations to identify the location of the HMC ports.
- You can verify that the Ethernet cable connection is active by observing the green status lights at both the HMC and managed system Ethernet ports while your installation progresses.

- Connect the Ethernet port on the HMC to the Ethernet port that is labeled **HMC1** on the managed server.

If you are connecting a second HMC to your managed server, connect to the Ethernet port that is labeled **HMC2** on the managed server.

7. If you use an external modem, plug the modem power supply cord into the HMC modem.
8. Plug the power cords for the monitor, HMC, and HMC external modem into electrical outlets.

Note: Do not connect the managed system to a power source at this time.

9. If you are setting up the HMC to manage an existing server, continue with “Preparing for HMC configuration” on page 54.

Note: For a complete list of HMC supported external cables, refer to the Serial attached SCSI cable planning topic.

Chapter 6. Troubleshooting the HMC

Learn how to correct a *No connection*, *Incomplete*, *Recovery*, or *Error* state on a system managed by an HMC.

Correcting a *No connection* state for a managed system

The *No connection* state can occur when the HMC is not connected, or the connection with the managed system failed.

Use this procedure for a system that was previously connected to the same HMC and is now in *No connection* state. If you have a new system, a new HMC, or have moved your system to a different HMC, refer to “Correcting a connection problem between the HMC and a managed system” on page 31.

1. Obtain the IP address for the managed system’s service processor by performing the following steps.
 - a. On the HMC, right-click the desktop and select **terminal** → **rshterm**. The restricted shell command line interface opens.
 - b. At the terminal, issue the command: `lssysconn -r all`
Information similar to the following is displayed:

```
resource_type=sys,type_model_serial_num=9117-570*100729E,sp=unavailable,ipaddr=10.0.0.247,alt_ipaddr=unavailable,state=No Connection,connection_error_code=Connecting_0000-0000-00000000
```
 - c. At the terminal, issue the ping command to the address of the failing system. In the previous example, you would type: `ping 10.0.0.247`.
2. Choose from the following options:
 - If the ping *is* successful, go to step 3.
 - If the ping *is not* successful, go to step 4.
3. If the ping test *is* successful, perform the following steps:
 - a. If your system is equipped with a control panel, ensure that there are no steady (nonscrolling) reference codes displayed on the panel.

Note: A steady reference code might indicate a hardware problem. Contact your next level of support or your hardware service provider.

- b. Restart the HMC.
 - c. If restarting the HMC does not resolve the problem, contact your next level of support or your hardware service provider.
4. If the ping test *is not* successful, perform the following steps:
 - a. If your system is equipped with a control panel, ensure that there are no steady (nonscrolling) reference codes displayed on the panel.

Note: A steady reference code might indicate a hardware problem. Contact your next level of support or your hardware service provider.

- b. If your system has a control panel, check to see if the power light is on.
- c. Choose from the following options:
 - If there is power to the managed system, go to step 5 on page 28.
 - If there is no power to the managed system, refer to “HMC and system power on and power off procedures” on page 32. After the power is restored, wait 5 minutes for the service processor to restart and the HMC to re-establish contact. If the system is equipped with redundant service processors, allow up to 20 minutes for this step.

5. Verify physical network connectivity by performing the following steps:
 - a. Verify that the HMC and the service processor are correctly connected to your Ethernet network.
 - b. Verify that Ethernet link status is good on all network segments which exist between the HMC and the managed system.
 - c. If you think the network might be the problem, connect a cable from the HMC to the service processor and try pinging the failing system. Then choose from the following options:
 - If the ping is successful, replace the cables the way they were and correct the network problem. After the network problem is resolved, repeat this entire procedure.
 - If the ping is not successful, replace the cables the way they were and continue with step 5d.
 - d. Reset the service processor. See “Resetting the service processor” on page 32.
6. If the problem is not resolved by any of the above steps, contact your next level of support or your hardware service provider.

Correcting an *Incomplete* state for a managed system

The *Incomplete* state can occur when the HMC failed to get all of the necessary information from the managed system.

To correct an *Incomplete* state, perform the following steps:

1. From the navigation area, select Servers.
2. From the contents area, select the managed system.
3. **Select Tasks > Operations > Rebuild Managed System.**
4. Choose from the following options:
 - If the state remains as *Incomplete*, rebuild the managed system several more times.
 - If the state goes to *Recovery*, see “Correcting a Recovery state for a managed system.”
 - If the state does *not* remain as *Incomplete* or go to *Recovery*, continue with the next step.
5. Reset the connection from the HMC. See “Resetting the managed system connection from the HMC” on page 32. If the connection still fails, continue with the next step.
6. Restart the HMC. Then choose from the following options (This next step might take several minutes to complete):
 - If the state goes to *Recovery*, see “Correcting a Recovery state for a managed system.”
 - If the state remains *Incomplete*, perform the following steps:
 - a. Verify that there is a redundant HMC.
 - b. Verify that no one is entering commands from the alternate HMC.
 - c. Repeat step 1 through 6. If the connection still fails, continue with the next step.
7. If the problem persists, contact your next level of support or your hardware service provider.

Correcting a Recovery state for a managed system

The Recovery state can occur when the save area in the service processor assembly is not synchronized with the HMC database.

To recover from the Recovery state, perform the following steps:

1. Recover partition data. For details, see “Recovering partition data on a managed system” on page 29. If this resolves the problem, this ends the procedure.
2. If the problem is not resolved after recovering profile data, choose one of the following:
 - If the state remains in *Recovery*, retry recovering partition data. If it fails a second time, follow the problem determination procedure for any reference codes you receive.

- If the state changed to *Incomplete*, refer to “Correcting an *Incomplete* state for a managed system” on page 28.
- If the state changed to *No Connection*, refer to “Correcting a *No connection* state for a managed system” on page 27.
- If the problem persists, contact your next level of support or your hardware service provider.

Recovering partition data on a managed system

Learn how to recover the partition data on your managed system if the partition becomes corrupted.

Through the HMC interface, you can recover partition data on your managed system if the data becomes damaged. This partition data includes information about logical partitions, partition profiles, and system profiles. If the partition data on your managed system becomes damaged, the managed system is in *Recovery* state. You can either restore the partition data from a backup file that is saved automatically on your HMC, or clear all partition configuration.

This procedure recovers the partition data in the service processor of your server. To recover the partition data on your managed system, see “Restoring profile data.”

Note: The HMC might not show *operating* state for the managed system after completing this recovery procedure. After a partition is activated, the managed system changes to an *operating* state and clears the A700 4091 or C700 4091 system reference code (SRC).

To recover the partition data on your managed system, you must be a member of one of the following roles:

- Super administrator
- Operator

To recover the partition data on your managed system, do the following:

1. In the Navigation Area, open **Server and Partition**.
2. Select **Server Management**.
3. In the contents area, right-click the managed system whose partition data you want to recover and select **Recover Partition Data**.
4. Select one of the following:
 - **Restore profile data from HMC backup data:** This option restores the partition data using the backup file that is saved automatically on the HMC.
 - **Initialize the managed system:** This option clears all partition configuration data, and can only be used if all partitions are in the *Not Activated* state.
5. Click **OK**.

Restoring profile data

Learn how to read the profile data from the previously backed-up file on the HMC, and load this data to the managed system.

Selecting this menu item restores profile data to the HMC from a backup file stored on the HMC hard drive.

Note: This is not a concurrent procedure. When the data is restored, the managed system powers on to Partition Standby.

To restore stored profile data on the HMC hard drive, you must be a member of one of the following roles:

- Super administrator
- Service representative

To restore profile data, do the following:

1. In the Contents area, select the managed system.
2. From the menu, select **Selected > Profile Data > Restore**.
3. From the list of backup files, select the profile information that you want to restore .
4. Select a restore option.
5. Click **OK**.

Correcting an *Error* state for a managed system

The *Error* state automatically generates a call to the service support center if the automatic call support function is enabled.

If the automatic call support function is not enabled, contact your next level of support or your hardware service provider.

Correcting a *Failed Authentication* state for a managed system

The *Failed Authentication* state can occur when the HMC access password for the managed system is not valid.

Perform the following procedure to correct a failed authentication state on your HMC.

1. Do you have an HMC password?
 - **Yes:** Enter the HMC password and choose from the following options:
 - If the managed system goes to *Operating*, *Power Off*, or *Standby*, the authentication was successful. **This ends the procedure.**
 - If the managed system goes to *No connection*, *Incomplete*, *Recovery*, or *Error* state, refer to Chapter 6, “Troubleshooting the HMC,” on page 27.
 - **No:** Do you have an ASMI admin password?
 - **Yes:** Continue with step 2.
 - **No:** Contact your next level of support to request CE login. Then continue with step 2, using CE login instead of admin password for step 2a.
2. Perform the following steps:
 - a. Log in to the ASMI with admin authority.
 - b. Select **Login Profile**.
 - c. Select **Change Password**.
 - d. In the User ID to change field, select **HMC**.
 - e. Enter the ASMI’s admin password in the **Current Password** for user ID admin field.

Note: Do not enter the HMC user password. Enter the ASMI’s *admin* password.
 - f. Enter a new HMC access password twice and click **Continue**.
 - g. From the HMC Server Management window, select **Update the managed system password**.
 - h. Enter the new password that was set in step 2f. **This ends the procedure.**
3. If the problem is not resolved, contact your next level of support or your hardware service provider.

Correcting a connection problem between the HMC and a managed system

Learn how to correct a connection problem between the HMC and a managed system.

Use this procedure in the following situations:

- You have a new HMC
- You have a new system
- You are using a different HMC to manage your system.

If your system was previously connected to the same HMC and is now in *No connection* state, refer to “Correcting a *No connection* state for a managed system” on page 27.

1. Choose from the following options:

- If the system uses DHCP addressing, go to step 2.
- If the system uses static addressing, go to step 6.

Note: To find out if your system uses DHCP or static addressing, perform one of the following:

- Use the ASMI by selecting **Network Services** → **Network Configuration** and viewing whether the IP address field shows *Static* or *Dynamic*.
 - If you have a control panel, use function 30.
2. If your system uses DHCP addressing, add a system automatically by issuing the following command: `mksysconn -o auto`.
- Is the system displayed?
- **Yes: This ends the procedure.**
 - **No:** Continue with step 3.
3. Check for network problems, cables, switches, link lights on the service processor, and so on.
- Was there a problem?
- **Yes:** Correct the problem and return to step 2.
 - **No:** Continue with step 4.
4. Reset the service processor to force it to request a new IP address. Refer to “Resetting the service processor” on page 32.
5. Did resetting the service processor resolve the problem?
- **Yes: This ends the procedure.**
 - **No:** Contact your next level of support.
6. If your system uses static IP addressing, add a system manually by performing the following steps:
- a. From the HMC, select **Server Management**.
 - b. Select **Add Managed System**.
 - c. Click **Add a managed system**.
 - d. Enter the IP address/Hostname and password.
- Is the system displayed under system management?
- **Yes: This ends the procedure.**
 - **No:** Contact your next level of support.

Resetting the managed system connection from the HMC

Use this procedure to reset the managed system connection from the HMC.

Perform these steps to reset the managed system connection:

1. In the navigation area, open **Systems Management**.
2. Select **Servers**.
3. In the contents area, select the server on which you want to reset the connection.
4. In the **Tasks** area, open **Connections**.
5. Select **Reset or Remove Connection**.
6. Select **Reset Connection**.
7. Click **OK**.

Resetting the service processor

Use this procedure to reset the service processor.

Use this procedure *only* under the direction of your next level of support or your hardware service provider. During this procedure, you will be powering off the system and removing and reapplying ac power.

1. Inform anyone using the server that it will be shut down.
2. Stop all applications that are running on the server.
3. Stop the operating system and server by choosing from the following options:
 - If you have an HMC, shut down all logical partitions and the server. For instructions, see “HMC and system power on and power off procedures.” Then continue with step 6.
 - If you do *not* have an HMC, continue with the next step.
4. Log in to the system as a user with the authority to run the appropriate shutdown command.
5. At the command line, enter one of the following commands:
 - If your system is running the AIX[®] operating system, type `shutdown`
 - If your system is running the IBM i operating system, type `PWRDWN SYS *IMMED`
 - If your system is running the Linux[®] operating system, type `shutdown -h now`

These commands stop the operating system. The system power turns off, the power-on light begins to slowly blink, and the system goes into a standby state.

6. Unplug the ac power cord and then plug it back in.
7. Start the server. The service processor is reset. **This ends the procedure.**

HMC and system power on and power off procedures

Use one or more of the following procedures to power on or power off your HMC or system.

Power on the HMC

During the process of powering on, the HMC checks to see which managed systems are available and communicating with the console. To ensure that each managed system is available before you power on the HMC, managed systems must be in standby mode or actively operating. Standby mode is indicated by the OK shown in the operator panel after the managed system has the power connected and the initial tests are complete.

Note: If the managed system is in an emergency power off (EPOW) condition, the managed system must be brought to standby mode before the HMC can be used to power on the system.

To power on the HMC, do the following:

1. Press the Power button once to turn on the power.
2. When the system has finished the power-on self-test (POST), log in to the HMC.

Power off the HMC

Attention: If possible, shut down all applications and partitions before powering off the system. Using either the power-on button on the control panel or entering commands at the HMC to stop the system can cause unpredictable results in the data files. Also, the next time you start the system, it might take longer if all applications are not ended before stopping the system.

To power off the HMC, log in to the HMC and select Power off. The HMC shuts down any applications that are running, and then turns off the HMC.

Power-on self-test

After power is turned on and before the operating system is loaded, the system does a power-on self-test (POST). This test performs checks to ensure that the hardware is functioning correctly before the operating system is loaded. During the POST, codes indicating the progress of the POST might be displayed. After the POST is complete, the HMC operating machine code loads and a login prompt is displayed.

Power on a system using an HMC

To power on a managed system, complete the following steps:

1. In the Navigation area, expand the **Systems Management** icon.
2. Expand the **Servers** icon.
3. Select the check box next to the name of the desired server. The tasks available for that server will be enabled.
4. From the **Tasks** menu, choose **Operations** -> **Power on**. Follow any additional on-screen instructions.

Power off a system using an HMC

Attention: If possible, shut down the running logical partitions on the managed system before powering off the managed system. Powering off the managed system without shutting down the logical partitions first causes the logical partitions to shut down abnormally and can cause data loss.

1. In the Navigation area, expand the **Systems Management** icon.
2. Expand the **Servers** icon.
3. Select the check box next to the name of the desired server. A selection of tasks available for that server will be displayed.
4. From the **Tasks** menu, select **Operations** > **Power off**. Follow any additional on-screen instructions.
5. Continue with “Remove the power cords” on page 34.

Install the power cords

Before powering on a system, ensure that the power cords have been plugged in to all of the power supplies on all of the processor enclosures.

Install the cords in the following order:

1. Secondary 2
2. Secondary 3
3. Primary

4. Secondary 1

Remove the power cords

The system might be equipped with a second power supply. Before continuing with this procedure, ensure that all power sources to the system have been completely disconnected.

1. Unplug any power cables that are attached to the unit from electrical outlets.
2. Remove all power cords from all of the processor enclosures starting with the primary processor enclosure (topmost) and then each secondary enclosure working from top to bottom.

Reinstalling the HMC machine code

Explains how to reinstall the interface and HMC machine code prior to restoring critical backup data.

If the HMC is not responding, you can use the recovery CD to reinstall the HMC onto the HMC PC. After you reinstall the HMC machine code, you can restore the backup data that you created to recover your critical console information. For information about how to restore the HMC backup data, see “Restoring critical HMC data” on page 35.

To reinstall the HMC machine code, you must be a member of one of the following roles:

- super administrator
- operator
- service representative

Note: If the F12 function key is not enabled, see “Setting up the network interface as a startup device” on page 36 to enable it.

To reinstall the HMC machine code, do the following:

1. Shut down and power off the HMC. If necessary, see “Shutting down, logging off, and disconnecting the HMC” on page 55.
2. If you are installing the HMC interface or machine code from the network, go to step 3. If you are installing the HMC interface or machine code from recovery media, do the following:
 - a. Install the recovery media.
 - b. Power on the HMC. The HMC powers on from the media and displays the Backup/Upgrade/Restore/Install window.
 - c. Select the Install option, and click **Next**.
 - d. Select **Install from media**. Click **Next**.
 - e. When prompted to install the additional media. Select **1 - Install additional software from media**.
 - f. Select **1 - Restore Critical Console Data** from the menu to restore data from a DVD. **This completes this procedure.**
3. Prior to reinstalling the HMC interface or machine code from a network ensure the following is in place:
 - a. The network boot server must be configured.
 - b. The network interface is one of the devices in your startup sequence. To view the list of startup devices, press F12 when the HMC powers on, and select the network interface from which you want to boot
4. To install the HMC interface or machine code from a network, do the following:
 - a. Select the Install option, and click **Next**.
 - b. Select **Install from network**. Click **Next**.
 - c. To finish the restore from a remote server, select **2 - Finish the Installation**.

Back up partition profiles

Refer to this procedure when needing to back up a partition profile.

To back up partition profile data, you must be a member of one of the following roles:

- super administrator
- service representative

To back up partition profile data, do the following:

1. In the Contents area, select the managed system.
2. From the menu, click **Selected > Profile Data > Backup**.
3. Type the name you want to use for this backup file.
4. Click **OK**.

Restoring critical HMC data

Restore critical HMC data.

Restore HMC backup data *only* in conjunction with a reinstallation of the HMC. For information about how to reinstall the HMC, see “Reinstalling the HMC machine code” on page 34.

Note: For this operation, you must have one of the following:

- The backup DVD media
- Access to the remote server where the archive was created by using the procedure in “Backing up critical HMC data” on page 53

To restore the HMC data, you must be a member of one of the following roles:

- super administrator
- operator
- service representative

Select the data-restoration procedure based on the data archiving method used:

If the critical console data has been archived on a DVD, do the following:

1. Select **1 - Restore Critical Console Data** from the menu displayed at the end of the HMC reinstallation.
2. Insert the DVD containing the archived console data. On the first boot of the newly installed HMC, the data is automatically restored.

If the critical console data from a remote server, do the following:

1. Manually reconfigure network settings to enable access to the remote server after the HMC is newly installed. For information about configuring network settings, see *Configuring the HMC*.
2. In the Navigation area, click the **Licensed Internal Code Maintenance** icon.
3. In the Contents area, click the **HMC Code Update** icon.
4. Select **Restore Remote Console Data**.
5. Select the type of remote restoration.
6. Follow the directions on the window to restore the critical console data. The data automatically restores from the remote server when the system is rebooted.

Setting up the network interface as a startup device

This section describes how to enable the F12 function key to set up the network interface as a startup device.

On some HMC models, the F12 function key is not enabled for use when the HMC is powered on. These steps enable the F12 function key so that you can specify the network interface as a startup device.

To set up the network interface as a startup device, you must be a member of one of the following roles:

- super administrator
- operator
- service representative

To set up the network interface as a startup device, do the following:

1. Shut down and power off the HMC. For more information, see “Shutting down, logging off, and disconnecting the HMC” on page 55.
2. Power on the HMC console.
3. Press F1 to start the BIOS Setup utility.
4. Find and select **Startup** or **Start Options**.
5. Select **Startup Sequence** to view the list of startup devices.
6. Depending on the type of HMC (stand-alone or rack-mounted), use the +/- key or arrow key to make the network interface an entry in the startup list, after the hard disk.
7. If the HMC is a stand-alone model, find and enable the Start up Device Menu prompt. This enables the F12 function key when the HMC powers on, so that you can select the network device in your startup list.

For CR2 and CR3 machine types, the Planar Ethernet PXE/DHCP entry should have Planar Ethernet 1 and Planar Ethernet 2.

On desktop HMC machines, do the following:

- a. Press Esc.
 - b. Select **Devices -> Network Setup**.
 - c. Ensure that **PXE Boot Agent** and **PXE Base code** are set to **Enabled**. If these settings are not enabled, networking will not occur.
8. Save the settings and exit the BIOS setup utility to restart the boot process.

You can now press F12 to select the network device as the startup device. If a DHCP server can accept PXE requests from the HMC, and has the required files, the HMC will boot from it. The Backup/Upgrade/Restore/Install window opens.

The **chhmc** command can be used on some HMC machine types to set the network interface as a startup device. To enable network boot on the HMC, use the following command:

```
chhmc -c netboot -s enable
```

When the command completes, run the following command to verify that network boot has been enabled:

```
lshmc -r
```

The command then displays the following:

```
ssh=enable,xntp=disable,websm=enable,http=enable,netboot=enable
```

To disable network boot, use the **chhmc** command:

```
chhmc -c netboot -s disable
```

Upgrading the machine code on an HMC from Version 6 to Version 7

Learn how to upgrade the machine code on an HMC from Version 6 to Version 7 while maintaining your HMC configuration data.

Perform Steps 1 through 9 to upgrade machine code on an HMC from Version 6 to Version 7.

Important: You must be at a minimum of HMC machine code Version 6 Release 1.2 to upgrade to Version 7 Release 3.1.0.

Step 1. Obtain the upgrade

You can order the HMC machine code upgrade through the Fix Central Web site, by contacting service and support, or by downloading it to an FTP server.

Note: If you do not have access to the Internet, contact service and support to order the upgrade on DVD.

1. From a computer or server with an Internet connection, go to the Fix Central Web site at <http://www.ibm.com/support/fixcentral/> .
2. Select the appropriate family in the Product family list.
3. Select **Hardware Management Console** in the Product or fix type list.
4. Click **Continue**. The Hardware Management Console site is displayed.
5. Navigate to the HMC version that you want.
6. Locate the Recovery CD download and ordering section.
7. Follow the on-screen prompts to submit your order.
8. After you receive the upgrade, continue with “Step 2. Back up critical console information.”

Step 2. Back up critical console information

Back up critical console information before installing a new version of HMC software so that previous levels can be restored in the event of a problem while upgrading the software. Do not use this critical console data after a successful upgrade to a new version of the HMC software.

Note: If you choose to back up the console data to removable media (that is, diskette or DVD), you will need to have a diskette or DVD available.

1. Choose from the following options:
 - If you do *not* plan to back up to diskette or DVD-RAM, continue with the next step.
 - If you plan to back up to diskette or DVD-RAM, perform the following steps:
 - a. Insert the media into the drive.
 - b. Select **Format Removable Media**.
 - c. Select **Format DVD-RAM** or **Format diskette**.
 - d. Click **OK**.
 - e. Continue with the next step.
2. Select **Back up Critical Console Data**.

3. Select an archive option. You can back up to a DVD in the HMC, a remote system mounted to the HMC file system (for example, NFS), or send the backup to a remote site using File Transfer Protocol (FTP).
 - To back up to DVD, choose **Back up to DVD on local system** and follow the instructions.
 - To back up to a mounted remote system, choose **Backup to mounted remote system** and follow the instructions.
 - To back up to a remote FTP site, choose **Send backup critical data to remote site** and follow the instructions.
4. Continue with “Step 3. Record the current HMC configuration information.”

Step 3. Record the current HMC configuration information

Before you upgrade to a new version of HMC software, as a precautionary measure, record HMC configuration information.

To record HMC configuration information, follow these steps:

1. In the navigation area, open **HMC Management**.
2. Select **HMC Configuration**.
3. In the tasks list, select **Schedule Operations**. The Scheduled Operations window opens with a list of all managed systems.
4. Select the HMC you plan to upgrade and click **OK**. All scheduled operations for the HMC are displayed.
5. Select **Sort** → **By Object**.
6. Select each object and record the following details:
 - Object Name
 - Schedule date
 - Operation Time (displayed in 24-hour format)
 - Repetitive (if Yes, perform the following steps):
 - a. Select **View** → **Schedule Details**.
 - b. Record the interval information.
 - c. Close the scheduled operations window.
 - d. Repeat for each scheduled operation.
7. Close the Customize Scheduled Operations window.
8. Continue with “Step 4. Record remote command status.”

Step 4. Record remote command status

1. In the navigation area, select **HMC Management**.
2. Select **HMC Configuration**.
3. In the tasks list, click **Enable/Disable Remote Command Execution**.
4. Record whether the **Enable remote command execution using the ssh facility** check box is selected.
5. Click **Cancel**.
6. Continue with “Step 5. Save upgrade data.”

Step 5. Save upgrade data

You can save the current HMC configuration in a designated disk partition on the HMC. Only save upgrade data immediately prior to upgrading your HMC software to a new release. This action allows you to restore HMC configuration settings after upgrading.

Note: Only one level of backup data is allowed. Each time you save upgrade data, the previous level of data is overwritten.

1. In the navigation area, open the **Licensed Internal Code** folder.
2. Select **HMC Code Update**.
3. Select **Save Upgrade Data**.
4. Select **Hard Drive** and click **Continue**.
5. Click **Continue** to start the task.
6. Wait for the task to complete. If the Save Upgrade Data task fails, contact your next level of support before proceeding.

Note: If the save upgrade data task fails, do not continue the upgrade process.

7. Click **OK**.
8. Click **Close**.
9. Continue with “Step 6. Upgrade the HMC software from Version 6 to Version 7.”

Step 6. Upgrade the HMC software from Version 6 to Version 7

To upgrade the HMC software, do the following:

1. Insert the HMC Product Installation DVD-RAM into the DVD-RAM drive.
2. Select **Upgrade** and click **Next**.
3. When the message is displayed, choose from the following options:
 - If you have saved upgrade data during the previous task, continue with the next step.
 - If you did not save upgrade data previously in this procedure, you must save the upgrade data now before you continue.
4. Select **Upgrade from media** and click **Next**.
5. Confirm the settings and click **Finish**.
6. Follow the on-screen prompts.

Note:

- If the screen goes blank, press the space bar to view the information.
 - The first DVD can take approximately 20 minutes to install.
7. When prompted, remove the first media and then insert the second media into the DVD-RAM drive.
 8. Select **1. Install additional software from media** and press Enter. Press any key to confirm the installation. The HMC will display status messages while it installs the packages.
 9. When the second media installation is complete, remove the media from the drive and close the drawer.
 10. Select **Option 2 Finish the installation** and press Enter. The HMC will complete the booting process.
 11. Accept the License Agreement for Machine Code twice.
 12. At the login prompt, log in using your user ID and password. The HMC code installation is complete.
 13. Continue with “Step 7. Verify that the HMC machine code upgrade installed successfully.”

Step 7. Verify that the HMC machine code upgrade installed successfully

1. Verify that the version and release match the update that you installed.
2. If the level of code displayed is not the level that you installed, perform the following steps:
 - a. Retry the update using a different DVD.

- b. If the problem persists, contact your next level of support.

HMC problem analysis

Use this information to diagnose and repair problems that are related to the Hardware Management Console (HMC).

DANGER

When working on or around the system, observe the following precautions:

Electrical voltage and current from power, telephone, and communication cables are hazardous. To avoid a shock hazard:

- Connect power to this unit only with the IBM provided power cord. Do not use the IBM provided power cord for any other product.
- Do not open or service any power supply assembly.
- Do not connect or disconnect any cables or perform installation, maintenance, or reconfiguration of this product during an electrical storm.
- The product might be equipped with multiple power cords. To remove all hazardous voltages, disconnect all power cords.
- Connect all power cords to a properly wired and grounded electrical outlet. Ensure that the outlet supplies proper voltage and phase rotation according to the system rating plate.
- Connect any equipment that will be attached to this product to properly wired outlets.
- When possible, use one hand only to connect or disconnect signal cables.
- Never turn on any equipment when there is evidence of fire, water, or structural damage.
- Disconnect the attached power cords, telecommunications systems, networks, and modems before you open the device covers, unless instructed otherwise in the installation and configuration procedures.
- Connect and disconnect cables as described in the following procedures when installing, moving, or opening covers on this product or attached devices.

To Disconnect:

1. Turn off everything (unless instructed otherwise).
2. Remove the power cords from the outlets.
3. Remove the signal cables from the connectors.
4. Remove all cables from the devices

To Connect:

1. Turn off everything (unless instructed otherwise).
2. Attach all cables to the devices.
3. Attach the signal cables to the connectors.
4. Attach the power cords to the outlets.
5. Turn on the devices.

(D005)

If you were directed here from the Beginning problem analysis procedure because your HMC is not functioning correctly, continue with the "Entry point for HMC problem determination" on page 41.

To perform other maintenance tasks on your HMC, refer to the following procedures:

- For general maintenance information on the base personal computer that is used to build the HMC, see Chapter 2, "HMC diagnostics," on page 5.
- For instructions to replace an HMC, see Replacing an HMC.
- For HMC parts information, refer to the following:
 - Hardware Management Console (HMC) parts. Because the personal computer that is used for your HMC can be serviced by the customer, you are the service provider for your HMC.

- To find links to the appropriate personal computer hardware maintenance information, see “Equivalent maintenance information for the HMC personal computer hardware” on page 5.
- For removing and replacing HMC parts, see Chapter 3, “Removal and replacement procedures,” on page 9.
- For backing up critical disk drive information on the HMC, refer to the Backing up critical HMC data topic.
- For restoring disk drive information on the HMC, refer to Reinstalling the HMC machine code .
- For checking modem settings, refer to the Cabling the HMC topic.

Entry point for HMC problem determination

Find the symptom you are having in the Symptom column of the following table. Then perform the action described in the Action column.

Symptom	Action
Operator reported that the HMC did not start, but no other problems were reported.	Go to “Beginning HMC problem determination” on page 42.
Operator reported “Communication not active” on the HMC.	Go to “Testing the HMC Ethernet adapter” on page 46.
Operator reported communication problems with a remotely connected HMC or a managed system.	Go to “Testing the modem connection to the managed system” on page 44.
Power problems	Go to “Testing for a power problem” on page 43.
HMC boot problems	Go to “Beginning HMC problem determination” on page 42.
Display problem	Go to “Testing the HMC display” on page 50.
DVD-RAM drive problem	Go to “Testing the HMC DVD-RAM drive” on page 48.
Diskette drive problem	Go to “Testing the HMC diskette drive” on page 49.
Ethernet LAN problem	Go to “Testing the HMC Ethernet adapter” on page 46.
A problem with any of the following: <ul style="list-style-type: none"> • display • diskette drive • DVD-RAM Drive • disk drive • Ethernet LAN 	Go to “Performing system unit testing using PC-Doctor” on page 44.
Eight character error code beginning with <i>HMC</i> was received when using the HMC graphical user interface.	Go to the “HMC system reference code” on page 5.
HMC does not communicate through the modem.	Go to “Testing the HMC modem connection” on page 44.
PC-Doctor diagnostic tests detected an error.	For PC hardware maintenance manuals to help isolate the problem to a failing part, refer to “Equivalent maintenance information for the HMC personal computer hardware” on page 5.
Problems understanding the usage of the HMC.	Go to Managing the Hardware Management Console.
All other problems (for example: HMC GUI is unresponsive, parity errors, power, POST codes, blank display, mouse, or keyboard).	Go to “Beginning HMC problem determination” on page 42.

Symptom	Action
Symptoms not in this list.	Go to "Beginning HMC problem determination."

Beginning HMC problem determination

Use this procedure to determine if there is a problem with the HMC hardware. This procedure might direct you to procedures in various sections of this information or to personal computer maintenance information.

Step 1. HMC problem determination

1. If the HMC is running, shut down the console by exiting the graphical user interface. The PC power turns off automatically. If the PC cannot turn off the power, then turn the power switch off.
2. Turn on the HMC power.
3. Watch the console and allow enough time for the system to complete the POST and load the HMC machine code.
4. Watch and listen for the following failing symptoms during power-on:
 - POST error condition.
 - A series of beeps that indicate an error condition.
 - The HMC login screen and user interface fails to start.
 - A reference code or any other error information is displayed.
5. Do you have any of the failing symptoms during power on?
 - **No:** Continue with step 6.
 - **Yes:** Go to the "Equivalent maintenance information for the HMC personal computer hardware" on page 5.
6. Perform system unit testing using PC-Doctor. For details, see "Performing system unit testing using PC-Doctor" on page 44.
7. Does the PC-Doctor diagnostics diskette start and allow tests to be run on the PC system unit?
 - **No:** Go to "Testing for a power problem" on page 43.
 - **Yes:** Go to "Step 2. HMC problem determination."

Step 2. HMC problem determination

1. Perform system unit testing using PC-Doctor. For details, see "Performing system unit testing using PC-Doctor" on page 44. Select **System Unit** → **Run All Selected**.
2. Did the system unit tests detect errors?
 - **No:** Go to "Step 3. HMC problem determination."
 - **Yes:** Continue with step 3.
3. Use the PC-Doctor diagnostics and the maintenance procedures for the type of PC that you are working on to isolate the failure and exchange customer replaceable units (CRUs). Refer to the publications listed in the "Equivalent maintenance information for the HMC personal computer hardware" on page 5.
4. When the problem is repaired, or if the problem cannot be isolated, continue with "Step 4. HMC problem determination" on page 43.

Step 3. HMC problem determination

Attention: This step requires HMC support assistance. Contact HMC support before continuing.

1. If you are directed to reload the HMC from the recovery DVD and then reload the backup profile and configuration data, see Recovering the HMC.
2. After reloading the machine code from the recovery DVD, does the HMC start correctly?

- **No:** Contact your next level of support.
- **Yes: This ends the procedure.**

Step 4. HMC problem determination

Note: If you reach this step and you have not been able to isolate a failure, contact your next level of support for assistance.

1. Reinstall all CRUs that did not fix the problem.
2. You must have performed a repair action to continue. If you have not already done so, verify the repair. For instructions, see “Performing system unit testing using PC-Doctor” on page 44.
3. Did the system unit tests run without errors?
 - **No:** To troubleshoot the error, return to “Performing system unit testing using PC-Doctor” on page 44. Then return here and continue with step 4.
 - **Yes:** Continue with step 4.
4. Does the HMC communicate with all connected managed systems?
 - **No:** Go to “Testing the modem connection to the managed system” on page 44.
 - **Yes:** Did you exchange the system board or the system board battery?
 - **No: This ends the procedure.**
 - **Yes:** Recover the HMC. For details, see Recovering the HMC. **This ends the procedure.**

Testing the HMC

Use these procedures when you are directed to them from the HMC problem analysis procedure to test the HMC. If a failure is detected, you will be instructed to fix the failing part and then verify the repair.

Testing for a power problem

To troubleshoot a power problem on the PC, refer to the service documentation for the PC on which your HMC is based. For PC hardware maintenance manuals to help isolate the problem to a failing part, refer to the publications listed in “Equivalent maintenance information for the HMC personal computer hardware” on page 5.

Performing diagnostic procedures

You should have been directed here to test a specific part of the HMC. For problems in the following areas, see “Performing system unit testing using PC-Doctor” on page 44:

- Display
- Keyboard
- Mouse
- Floppy Drive
- DVD-RAM
- DASD (disk drive)
- Memory
- Power
- Run All Selected
- SCSI
- System Port/Modem
- 16/4 Port Serial
- Ethernet

To access the HMC diagnostic information, follow the procedures in Chapter 2, "HMC diagnostics," on page 5.

Performing system unit testing using PC-Doctor

This section provides information to help you use the PC-Doctor diagnostics. For information on running PC-Doctor, go to Chapter 2, "HMC diagnostics," on page 5.

Note: Performing procedures other than those specified in the following steps might cause errors.

1. Start the PC-Doctor diagnostics.
2. From the diagnostic selection display, select either **Diagnostics** or **Interactive Tests** for a list of devices to test:
 - Devices that require manual intervention (keyboard, video, mouse, diskette, optical drive) might be selected from the interactive tests task bar.
 - Devices that do not require manual intervention (processor, system board, I/O ports, fixed disks, memory) and predefined test sequences (Run Normal/Quick Test) can be selected from the diagnostic task bar.
3. Select the task containing the device or test and follow the instructions. If you were instructed to **Run All Selected**, continue with that selection.
4. If the diagnostics report a failure on the PC hardware, refer to the service documentation for the PC on which your HMC is based. For PC hardware maintenance manuals to help isolate the problem to a failing part, refer to the publications listed in "Equivalent maintenance information for the HMC personal computer hardware" on page 5.
5. If the diagnostics do not report a failure, the HMC PC hardware is functioning correctly. If you still have a problem, go to "Beginning HMC problem determination" on page 42.

Testing the modem connection to the managed system

Use this procedure to test the modem connection to the PC for the HMC.

1. Can the HMC be used to communicate through the modem?
 - **No:** Go to step 2.
 - **Yes: This ends the procedure.**
2. Is a device other than a modem attached to system port 2 on the HMC?

Note: If the HMC is a rack-mounted model, answer no to this question.

- **No:** Go to "Testing the HMC modem connection."
 - **Yes:** Go to step 3.
3. System port 2 of the HMC is reserved for external modem use only. Move the serial cable from serial port 2 of the HMC to another HMC system port. Connect the modem to system port 2 and go to step 1.

Note: If the HMC is a rack-mounted model, an internal modem is installed to handle the connection of the HMC to the telephone line. If a redundant telephone connection is required, connect an external modem to the system port on the rear of the HMC. If needed, go to the MultiTech MultiModem^{II} installation guide for modem installation instructions. If you do not have access to a hardcopy version

of the MultiTech MultiModem^{II} documentation, go to the MultiTech  Web site at <http://www.multitech.com/documents/families/multimodemII/manuals.asp>.

Testing the HMC modem connection

Use this procedure to test the modem connection to the PC for the HMC.

1. Verify that the modem and the telephone line are functioning correctly by performing the following steps:
 - a. On the HMC console, open the Service Agent application.
 - b. Select **Test Tools**.
 - c. Initiate a Test PMR.
 - d. Monitor the call log to verify that the call is completed successfully. If the call is completed successfully, the modem is functioning correctly.
2. Is the installed modem currently functioning on the HMC?
 - **No:** Go to step 3.
 - **Yes:** The problem is not in the modem. **This ends the procedure.**
3. Are the HMC configurations, relating to the modem operation, correct?
 - **No:** Correct the HMC configuration arguments. Return to step 1.
 - **Yes:** Continue with step 4.
4. Is the modem powered on? (Are any indicators lit?)
 - **No:** Ensure the modem is powered on. For details, see 1. After power on verification is completed, continue with step 5.
 - **Yes:** Go to step 5.
5. Is the serial cable between the serial (COM) port connector of the HMC and the modem attached?
 - **No:** Attach the serial cable between the serial (COM) port connector of the HMC and the modem.
 - **Yes:** Load the PC-Doctor diagnostics.
 - If you are working on a desktop model HMC, load the PC-Doctor from diskette or CD.
 - If you are working on a rack-mounted model HMC, load the PC-Doctor from diskette using an external USB diskette drive, CD or selecting F12 during a system shut down and restart.

Note: If you are using a CD or diskette to load PC-Doctor, shut down and restart the HMC and wait until the PC-Doctor main menu is displayed.
6. Click **Diagnostics** → **Other Devices** → **Modem** to perform the modem diagnostic test.
7. Did the diagnostic pass?
 - **No:** Go to step 8.
 - **Yes:** Go to 9.
8. Is the modem connected correctly to a working telephone line (or equivalent)?

Note: This can be checked by connecting a known good telephone to the line in place of the modem and making a telephone call.

 - **No:** Correctly connect the telephone line (or equivalent) to the modem. Go to step 1. After completing the telephone line and modem verification test, continue with step 9.
 - **Yes:** Go to step 9.
9. Verify the COM port by performing the following steps:
 - a. Disconnect the modem cable from the COM port of the HMC.
 - b. Select **Diagnostics** from the top menu.
 - c. Select **System Ports** from the pull-down menu. The *SERIAL PORT TEST CATEGORY* screen displays.
 - d. Ensure the following:
 - On desktop HMC models - IRQ numbers 4 and 3 are assigned to COM 1 and COM 2, and the planar to COM 2 connector cable is present and correctly installed.
 - On rack-mounted models - IRQ number 4 is assigned from COM 1.

Note: If the preceding information is not correct, the COM port might be disabled, or might be incorrectly configured. This can be resolved by accessing the setup utility (by pressing the F1 key) during power on.

- e. Ensure all diagnostics except **External Loopback** are selected.
- f. Select **Run Screen** from the bottom menu.
- g. Ensure all selected diagnostics show Passed.

Note: If any diagnostics fail, replace the planar.

10. Verify the external modem by performing the following steps:
 - a. Reconnect the modem cable to the correct COM port.
 - b. Ensure that the modem is powered on, connected to a working telephone line, and is securely cabled to the communications cable.
 - c. Press Esc to return to the PC-Doctor main menu or shut down and restart the HMC.
 - d. Select **Hardware Info** from the top menu.
 - e. Select **COM and LPT Ports** from the menu. The hardware query displays COM and LPT port information.
 - f. Verify the following:
 - A modem was detected on the correct COM port
 - The modem test returned Passed
 - Dial tone: Detected
 - ATII: Displays the modem's model information

Note:

- a. If you were not able to get the desired results in step 10f, refer to the MultiTech MultiModem^{II} user's guide, installation guide, or reference guide for your modem. To access the MultiTech MultiModem^{II} documentation, go to the MultiTech  Web site at <http://www.multitech.com/documents/families/multimodemII/manuals.asp>.
 - b. If necessary, after you have completed the MultiTech MultiModem^{II} documentation, return here to complete the final step of this procedure.
11. Choose from the following options:
 - If the modem was not detected, replace and verify the following customer replaceable parts in the order listed:
 - a. Communications cable
 - b. Modem
 - If the modem test did not return with Passed, replace the modem.
 - If the dial tone did not return with Detected, verify the telephone line operation then retest. If the failure reoccurs, replace the modem.

Testing the HMC Ethernet adapter

Use this procedure to test the Ethernet adapter in the HMC.

1. Is the Ethernet port currently functioning though normal operation of the HMC?
 - **No:** Go to step 2.
 - **Yes: This ends the procedure.**
2. Are the Ethernet configuration values set correctly? (IP address, subnet mask, and so on.)
 - **No:** Set the Ethernet configuration values to their correct settings. Then go back to step 1.
 - **Yes:** Go to step 3 on page 47.

3. Can the IP address of the HMC be 'pinged' by another system that should be able to 'see' the HMC on the network?
 - **No:** Go to step 4.
 - **Yes:** Go to step 9.
4. Is the Ethernet cable attached correctly to the HMC and the network?
 - **No:** Attach the HMC to the network using an Ethernet cable with the correct pinout. Then go to step 1 on page 46.
 - **Yes:** Go to step 5.
5. Is the Ethernet cable the correct pinout? (There are two types of Ethernet cables in use, which are distinguished by different pinouts. The network will determine which version of cable to use.)
 - **No:** Replace the Ethernet cable with the correct version. Then go to step 1 on page 46.
 - **Yes:** Go to step 6.
6. Perform the following steps:
 - a. Install the PC-Doctor diskette into drive A of the HMC: (floppy drive).
 - b. Shut down and restart the HMC and wait until the PC-Doctor main menu is displayed.
 - c. To run the Ethernet diagnostics, select **Diagnostics** → **Other Devices** → **Intel Ethernet**.
Did the diagnostic pass?
 - **No:** Go to step 7.
 - **Yes:** Go to step 9.
7. Refer to the Ethernet hardware's hardware maintenance manual to determine if there are any internal settings or jumpers that might disable the Ethernet port.
Are there any internal settings or jumpers?
 - **No:** Go to step 8.
 - **Yes:** Go to step 9.
8. Replace the Ethernet hardware in the HMC. (This might be a PCI card or system board replacement, depending on the HMC hardware.) Go to step 1 on page 46.
9. Set the internal settings/jumpers to enable the Ethernet port on the HMC. Go to step 1 on page 46.
The failure does not seem to be in the HMC.

Testing the HMC disk drive

Learn how to test and run diagnostics on a failing HMC disk drive

To test for HMC disk drive problems, complete the following steps:

1. Did the disk drive test fail?
 - **No:** Go to step 5 on page 48.
 - **Yes:** Continue with the next step.
2. Perform the following steps:
 - a. Exchange the CRUs called by the diagnostics one at a time. For CRU removal and replacement instructions, refer to the PC hardware maintenance manual for the system on which you are working. See "Equivalent maintenance information for the HMC personal computer hardware" on page 5 to access the hardware maintenance manual for your HMC personal computer model.
 - b. After each CRU is exchanged, test the repair using the information in "Performing system unit testing using PC-Doctor" on page 44. Select **Hard Disk Drive** problem area.
Did the disk drive test fail?
 - **No:** Continue with the next step.
 - **Yes:** Contact your next level of support.
3. Ensure the following and then continue with the next step:

- If you exchanged the disk drive and there are jumpers or tab settings on the new disk drive, ensure that the settings are the same as the old drive.
 - If there is a SCSI cable-terminating resistor device, ensure it is secured to the cable and (if necessary) reattached to its original location on the PC.
Go to "Hard Disk Jumper Settings" in the PC hardware maintenance manual. See "Equivalent maintenance information for the HMC personal computer hardware" on page 5 to access the hardware maintenance manual for your HMC personal computer model.
4. If you exchanged the disk drive, restore the HMC image to the new disk drive.
 5. Use the information in "Performing system unit testing using PC-Doctor" on page 44 to test the PC. Select **Run All Selected** problem area.
 - If the tests fail, isolate the problem using the "Beginning HMC problem determination" on page 42 procedure.
 - If the tests run without errors, turn off the PC power and then turn on the power. Ensure that the system boots and the HMC screen is displayed. **This ends the procedure.**

Testing the HMC DVD-RAM drive

Learn how to test and run diagnostics on a failing DVD-RAM

To test for HMC DVD-RAM drive problems, complete the following steps:

1. Determine the media in the DVD-RAM drive:
 - Compact Disk Recordable (CD-R) similar to a CD
 - DVD-RAM media cartridge

Is the media a CD-R?

 - **No:** Go to step 4.
 - **Yes:** Continue with the next step.
2. Perform the following steps:
 - a. Clean the compact disk as follows:
 - Hold the disk by its edges. Do not touch the surface.
 - Remove dust and fingerprints from the surface by wiping from the center to the outside using a dry, soft cloth.
 - b. Reinstall the CD, with the label-side facing up.
 - c. Continue with the next step.
3. Retry the failing task using the original media.
Does the failure occur again?
 - **No:** Continue with the next step.
 - **Yes:** Go to step 4.

This ends the procedure.
4. Ensure the write protect tab is in the "disabled" (down) position.
Was the write protect tab in the "disabled" (down) position?
 - **No:** Go to step 3.
 - **Yes:** Continue with the next step.
5. Perform the following steps:
 - a. With the original media in the drive, note the following:
 - If you are attempting a restore procedure, turn off the PC power.
 - For any other operation, shut down the HMC, and then turn off the PC power.

Note: For shutdown procedures, see HMC and system power on and power off procedures.

- b. Turn on the PC power and test the DVD-RAM drive using the information in “Performing system unit testing using PC-Doctor” on page 44.
 - c. Select **DVD-RAM Drive** problem area.
 - d. When the test is complete, return here and continue with the next step.
6. Did the DVD-RAM test fail while testing with the original media?
 - **No:** Go to step 1.
 - **Yes:** Continue with the next step.
 7. Exchange the original media with a new one.

Note: If you are replacing DVD-RAM media, the new cartridge must be formatted. If possible, use another HMC to format the new cartridge.

8. Turn off the PC power.
9. Turn on the PC power, and test the DVD-RAM drive with the new media. Use the information in “Performing system unit testing using PC-Doctor” on page 44 to test the PC. Select **DVD-RAM Drive** problem area.
10. Did the DVD-RAM test fail while testing with the new media?
 - **No:** The original media was defective. **This ends the procedure.**
 - **Yes:** Continue with the next step.
11. Verify the following:
 - All DVD-RAM drive data and power cables are secure.
 - The DVD-RAM drive is jumpered as “master” and is cabled to the secondary IDE bus.
12. If the diagnostics continue to fail, exchange the DVD-RAM drive. When complete, run the DVD-RAM test again.

Note: If there are any jumpers or tab settings on the new drive, ensure that the settings match the old drive.
13. Did the DVD-RAM Drive test continue to fail?
 - **No:** The original DVD-RAM drive was defective. **This ends the procedure.**
 - **Yes:** Continue with the next step.
14. Continue exchanging CRU from the CRU list and running the DVD-RAM drive tests.
 - If the CRUs fix the problem, this ends the procedure.
 - If you cannot isolate the problem, call your next level of support for assistance.
15. The PC resources (for example: interrupt, I/O address) might be configured incorrectly. Verify the PC resources are correctly configured.
 - a. Select **System Unit** for the configuration area, and verify configuration for the system unit and all adapters.
 - b. When you complete the verification, retry the failing procedure and continue with the next step.
16. Does the failing procedure continue to fail?
 - **No:** The resource settings were incorrect. **This ends the procedure.**
 - **Yes:** If you cannot isolate the problem, contact your next level of support for assistance. **This ends the procedure.**

Testing the HMC diskette drive

Using PC-Doctor learn to run a diagnostic test to determine diskette drive problems.

To test for HMC diskette drive problems, complete the following steps:

1. Perform the following steps:
 - a. Turn on the PC power and test the diskette drive using the information in “Performing system unit testing using PC-Doctor” on page 44.

b. Select **System Unit** problem area and the test of **Diskette Drive**.

Note: Do not test with the diskette on which the errors occurred. Use a new diskette.

c. When the test is complete, continue with the next step.

2. Did the diskette test fail while testing with a new diskette?
 - **No:** Go to step 6.
 - **Yes:** Continue with the next step.
3. Exchange the diskette drive and run the diskette test again.
4. Did the diskette test fail again?
 - **No:** The original diskette drive was failing. **This ends the procedure.**
 - **Yes:** Continue with the next step.
5. Continue exchanging CRUs from the CRU list and running tests. If one of the replaced CRUs fixes the problem, **this ends the procedure**. If you cannot resolve the problem, contact your next level of support for assistance.
6. Did the original failure occur while writing to a diskette?
 - **No:** Go to step 8.
 - **Yes:** Continue with the next step.
7. Retry the original task using a new diskette.
 - If the failure occurs again, go to step 10.
 - If no failures occur, the original diskette was failing. **This ends the procedure.**
8. Re-create the information on the diskette, or obtain a new diskette with the information.
9. Retry the original task.
 - If the failure occurs again, continue with the next step.
 - If no failures occur, the original diskette was failing. **This ends the procedure.**
10. Test the diskette drive, using the information in “Performing system unit testing using PC-Doctor” on page 44. Select **System Unit** problem area and the test of **Diskette Drive**.
 - If the tests fail, isolate the problem using the procedures found in the PC hardware maintenance manual. For additional PC maintenance information, see “Equivalent maintenance information for the HMC personal computer hardware” on page 5 to access the hardware maintenance manual for your HMC personal computer model.
 - If the tests do not isolate the problem, contact your next level of support for assistance.

Testing the HMC display

Learn to test and diagnose HMC display problems.

To test for HMC display problems, complete the following steps:

1. Is the display type a 95xx (17P, 17X, 21P)?
 - **No:** Continue with the next step.
 - **Yes:** 95xx-xxx repairs might require replacing internal display CRUs. Repair and test the display using the procedures in *Monitor Hardware Maintenance Manual Vol 2, S41G-3317*.
2. Is the display type a 65xx (P70, P200)?
 - **No:** Continue with the next step.
 - **Yes:** 65xx-xxx repairs might require replacing the entire display. There are no internal display CRUs. Repair and test the display using the procedures in *Monitor Hardware Maintenance Manual Vol 3, P and G series, S52H-3679*.
When the test and repair are complete, continue with step 5 on page 51.
3. Is the display type a 65xx (P72, P202)?

- **No:** Continue with the next step.
- **Yes:** 65xx-xxx repairs might require replacing the entire display. There are no internal display CRUs. Repair and test the display using the procedures in *Color Monitor Operating Instructions*.

When the test and repair are complete, continue with step 5.

4. Repair and test the display using the documentation included with the display. When the test and repair are complete, continue with step 6.
5. Verify the repair using the information in “Performing system unit testing using PC-Doctor” on page 44. Select **System Unit** for the problem area and the **Test for Display**.
When the test and repair are complete, continue to step 6.
6. Return the system to normal operations. **This ends the procedure.**

Replacing an HMC

Identifies the prerequisites needed and the tasks that must be performed when you replace a Hardware Management Console (HMC).

If you are replacing an HMC that is set up as a DHCP server, you must first reinstall the HMC code base by using one of the following:

- The recovery media that was provided with your HMC
- The recovery media that you last used to upgrade your HMC

You must also reinstall your customized HMC configuration data by using backup media.

Procedures for replacing an HMC differ, depending on which HMC version you have installed. To determine your HMC version, see *Determining your HMC machine code version and release* and then return here.

These instructions assume that you have created a backup of your HMC configuration data from the HMC being replaced. For more information about backing up important HMC data, see *Backing up critical HMC data*.

For HMC V4.5 or earlier

1. Insert the HMC recovery media, then power on or reboot the HMC. The HMC powers on and loads from the media.
2. Press F8 to select **Install/Recovery**.
3. Press F1 to continue. After the installation is complete, the HMC prompts you to insert the backup media.
4. Insert the backup media. When you are finished, the HMC is restored to the state that it was in at the time that the backup was created.
5. After the HMC interface has been restored, verify that your HMC DHCP private network is configured correctly. For more information, see *Verifying that your HMC DHCP private network is configured correctly*.

For HMC V5.0 or later

1. Insert the HMC recovery media, then power on or reboot the HMC. The HMC powers on from the media and displays the **Backup/Upgrade/Restore/Install** panel.
2. Select **Install** and click **Next**. Wait for the installation to complete.
3. Select **1 - Install additional software from media** from the menu displayed to install the second HMC recovery media.
4. Remove the recovery media and insert the second media.
5. Press Enter to start the installation of the second recovery media.

6. After the installation is complete, remove the second recovery media, insert the backup media, and select **1 - Restore Critical Console Data** from the menu to restore data from the backup media. When you are finished, the HMC is restored to the state that it was in at the time that the backup was created.
7. After the HMC interface has been restored, verify that your HMC DHCP private network is configured correctly. For more information, see [Verifying that your HMC DHCP private network is configured correctly](#).

Verifying that your HMC DHCP private network is configured correctly

Learn how to verify that all of your HMC DHCP private networks are configured correctly.

If your HMC is configured as a DHCP server on a private network and is not communicating correctly with the managed system, or you have recently modified your network configuration (moved a managed system, replaced an HMC, or added a second HMC), use the following instructions to determine if your DHCP-managed private network is configured correctly.

Note: If your HMC is set up as a DHCP server on a private network, do not use the static IP commands `mksysconn` and `rmsysconn` to change HMC connection settings. These commands are intended for use on a public network only, where the HMC is not set up as DHCP server and managed servers use static IP addresses.

If a system administrator previously assigned an IP address to the system through a manually executed static IP command, Support must remove the manual connection and establish a DHCP connection between the HMC and the server. This section describes how to identify any manually assigned IP addresses so that an authorized service provider can remove them.

To identify a manually assigned IP address so that your HMC can communicate correctly with your managed systems, you must perform the following high-level tasks. The following are detailed step-by-step task descriptions.

- Identify the configured HMC IP connection addresses and compare them to the list of IP addresses assigned by the DHCP server.
- Identify the HMC IP connection addresses that have been correctly assigned through the DHCP server, for which no further action is required.
- Identify any manually configured HMC IP connection addresses that DHCP did not assign and that need to be corrected by support.

To identify manually assigned IP addresses when the HMC is configured as a DHCP server, do the following

1. Create a list of all of the configured HMC IP connections. On the HMC command line, type the following command:

```
lssysconn -r all
```

This command displays the following information for service processors and Bulk Power Cards (BPCs) on the network for which the HMC has configured IP connection:

```
element type, MTMS, IP address(es), connection state
```

2. Make a note of all IP addresses that are displayed. You will need these addresses later.
3. Display a list of the DHCP IP addresses that have been assigned. To do this, type the following HMC command:

```
lshmc -n -F clients
```

The output of this command lists all IP addresses that have been assigned by the HMC's DHCP server.

4. Make a note of all IP addresses that are listed in the output.
5. Compare the lssysconn and lshmc lists. If an IP address is displayed in the output for both the lshmc -n -F clients and lssysconn -r all commands, the IP address was assigned by the HMC DHCP server and the connection is being managed by the HMC DHCP server.
6. Remove from the list any address that is displayed in the output of the lshmc -n -F clients command but not displayed in the output of the lssysconn -r all command, and is not in the list of servers that use static IP addresses.

Note: If an IP address is displayed in the lshmc -n output and not in the lssysconn -r all output, that IP address was assigned by the HMC DHCP server. However, it is not a current connection on the HMC. The DHCP server keeps a history of all IP address assignments in the event that the connection is re-established. The DHCP server might also have assigned an IP address if an unknown device on the private network requested a DHCP IP address from the HMC.

7. If the HMC is managing servers on both a private and a public network, any connections to the service processor on the public network (not in the private network address range) must also be identified and removed from this list. If there are no IP addresses remaining in the list that contains the lssysconn -r all output, the HMC DHCP server has assigned all of the system IP addresses, and the network configuration is working correctly.
8. If there are any IP addresses not removed from the list taken from the lssysconn -r all command, this address was not assigned by the HMC's DHCP server. These IP address assignments must be corrected, so that they can be automatically reassigned by the HMC DHCP server. Contact an authorized service provider and request that someone correct the manually assigned IP addresses that you have identified.

If you have followed this procedure and not all of your connections appear to be active, call an authorized service provider for additional support.

Backing up critical HMC data

You can back up important console information to DVD, to a remote system mounted to the HMC file system, such as Network File System (NFS), or to a remote site through File Transfer Protocol (FTP).

Using the HMC, you can back up all important data, such as the following:

- User-preference files
- User information
- HMC platform-configuration files
- HMC log files
- HMC updates through Install Corrective Service

The Backup function saves the HMC data stored on the HMC hard disk to DVD, a remote system mounted to the HMC file system (such as NFS), or a remote site through FTP. Back up the HMC after you have made changes to the HMC or to the information associated with logical partitions.

Note: Before data can be saved to the DVD, the DVD must be formatted in the DVD-RAM format.

To back up the HMC, you must be a member of one of the following roles:

- super administrator
- operator
- service representative

To back up the HMC critical data, do the following:

1. In the Navigation area, click **HMC Management**.

2. Select **Back up HMC Data**.
3. Select an archive option. You can back up to DVD on the local system, back up to a mounted remote system, or send backup data to a remote site.
4. Follow the instructions on the window to back up the data.

Determining your HMC machine code version and release

The level of machine code on the HMC determines the available features to upgrading to a new release, including concurrent server firmware maintenance and enhancements.

To determine how to view the HMC machine code version and release, complete the following steps:

1. In the Navigation area, click **Updates**.
2. In the Work area, view and record the information that is displayed under the HMC Code Level heading, including: the HMC version, release, maintenance level, build level, and base versions.
3. To update your HMC machine code version and release, see Obtaining HMC machine code updates and upgrades. **This ends the procedure.**

Preparing for HMC configuration

To configure the Hardware management Console (HMC), you must understand the related concepts to gather the required configuration settings that you need to know before you begin the configuration steps.

To prepare for HMC configuration, do the following steps:

1. Determine if this is a new HMC supporting one or more new systems, or if this is a second new HMC supporting existing systems. This will determine which installation path to follow.
2. Determine the physical location of the HMC in relation to the servers it will manage. If the HMC is more than 25 feet from its managed system, you must provide Web browser access to the HMC from the managed system's location so that service personnel can access the HMC.
3. Identify the servers that the HMC will manage.
4. Determine whether you will use a private or an open network to manage servers. The HMC manages the servers through the Flexible Service Processor (FSP) over a network connection. A *private* network is a non-routable network from the HMC to one or more FSPs. An *open* network is any routable network linking the HMC to FSPs, logical partitions, administrative workstations or other network devices, such as routers and firewalls. A private network is recommended for HMC management of all systems. Servers that have bulk power controllers require a private network with an HMC acting as a Dynamic Host Control Protocol server (DHCP). Review the available non-routable network subnet ranges that are available and determine which one you will use for each DHCP server. Each FSP may be connected to two HMCs acting as DHCP servers as long as they are using two different IP address ranges.
5. If you will use an open network to manage an FSP, you must set the FSP's address manually through the Advanced System Management Interface (ASMI) menus. A private, non-routable network is recommended.
6. Determine the open network settings that you will need to connect the HMC to workstations used by system administrators, logical partitions on the managed systems, and other network devices. Also, determine how the HMC will "call home." Call home options can include an outbound-only Secure Sockets Layer (SSL) Internet connection, a modem, or a Virtual Private Network (VPN) connection.
7. Determine the HMC users that you will create and their passwords, as well as which roles they will be given.
8. Document the following company contact information that will be needed when configuring call home:

- Company name
 - Administrator contact
 - e-mail address
 - Telephone numbers
 - Fax numbers
 - The street address of the HMC physical location
9. If you plan to use e-mail to notify operators or systems administrators when information is sent to IBM Service through call-home, identify the Simple Mail Transfer Protocol (SMTP) server and the e-mail addresses you will use.
 10. If this is a new HMC connecting to a new managed system, create a password that will be used to authenticate the HMC to the system's service processor. At the same time, create a password for the Advanced System Management Interface (ASMI) admin and general users. All three passwords can be set when connecting the first time from the HMC to a new server. If the new HMC is to be used as a redundant HMC, obtain the HMC user password from the already attached and configured HMC. Be prepared to enter the password when you first connect to the managed server's service processor.

Shutting down, logging off, and disconnecting the HMC

Learn how to shut down, log off, and disconnect the HMC interface.

Shut down, log off, and disconnect the HMC interface.

Attention: Only use the white button on the HMC to perform a manual shutdown if the server does not respond to any tasks performed from the console, such as shutting down the HMC.

If an operating system is running in a logical partition and you decide to shut down, reboot, or log off the HMC interface, the operating system continues to run without interruption.

Logging off the HMC

Perform the following steps:

1. In the main menu, click **Logoff**. The Choose to Logoff or Disconnect window opens.
2. Click **Log off**, then click **OK**.

Disconnecting from the HMC interface

To disconnect from the HMC interface, do the following:

1. In the main menu, click **Logoff**. The Choose to Logoff or Disconnect window opens.
2. Click **Disconnect**, then click **OK**.

Appendix. Notices

This information was developed for products and services offered in the U.S.A.

The manufacturer may not offer the products, services, or features discussed in this document in other countries. Consult the manufacturer's representative for information on the products and services currently available in your area. Any reference to the manufacturer's product, program, or service is not intended to state or imply that only that product, program, or service may be used. Any functionally equivalent product, program, or service that does not infringe any intellectual property right of the manufacturer may be used instead. However, it is the user's responsibility to evaluate and verify the operation of any product, program, or service.

The manufacturer may have patents or pending patent applications covering subject matter described in this document. The furnishing of this document does not grant you any license to these patents. You can send license inquiries, in writing, to the manufacturer.

The following paragraph does not apply to the United Kingdom or any other country where such provisions are inconsistent with local law: THIS INFORMATION IS PROVIDED "AS IS" WITHOUT WARRANTY OF ANY KIND, EITHER EXPRESS OR IMPLIED, INCLUDING, BUT NOT LIMITED TO, THE IMPLIED WARRANTIES OF NON-INFRINGEMENT, MERCHANTABILITY OR FITNESS FOR A PARTICULAR PURPOSE. Some states do not allow disclaimer of express or implied warranties in certain transactions, therefore, this statement may not apply to you.

This information could include technical inaccuracies or typographical errors. Changes are periodically made to the information herein; these changes will be incorporated in new editions of the publication. The manufacturer may make improvements and/or changes in the product(s) and/or the program(s) described in this publication at any time without notice.

Any references in this information to Web sites not owned by the manufacturer are provided for convenience only and do not in any manner serve as an endorsement of those Web sites. The materials at those Web sites are not part of the materials for this product and use of those Web sites is at your own risk.

The manufacturer may use or distribute any of the information you supply in any way it believes appropriate without incurring any obligation to you.

Any performance data contained herein was determined in a controlled environment. Therefore, the results obtained in other operating environments may vary significantly. Some measurements may have been made on development-level systems and there is no guarantee that these measurements will be the same on generally available systems. Furthermore, some measurements may have been estimated through extrapolation. Actual results may vary. Users of this document should verify the applicable data for their specific environment.

Information concerning products not produced by this manufacturer was obtained from the suppliers of those products, their published announcements or other publicly available sources. This manufacturer has not tested those products and cannot confirm the accuracy of performance, compatibility or any other claims related to products not produced by this manufacturer. Questions on the capabilities of products not produced by this manufacturer should be addressed to the suppliers of those products.

All statements regarding the manufacturer's future direction or intent are subject to change or withdrawal without notice, and represent goals and objectives only.

The manufacturer's prices shown are the manufacturer's suggested retail prices, are current and are subject to change without notice. Dealer prices may vary.

This information is for planning purposes only. The information herein is subject to change before the products described become available.

This information contains examples of data and reports used in daily business operations. To illustrate them as completely as possible, the examples include the names of individuals, companies, brands, and products. All of these names are fictitious and any similarity to the names and addresses used by an actual business enterprise is entirely coincidental.

If you are viewing this information in softcopy, the photographs and color illustrations may not appear.

The drawings and specifications contained herein shall not be reproduced in whole or in part without the written permission of the manufacturer.

The manufacturer has prepared this information for use with the specific machines indicated. The manufacturer makes no representations that it is suitable for any other purpose.

The manufacturer's computer systems contain mechanisms designed to reduce the possibility of undetected data corruption or loss. This risk, however, cannot be eliminated. Users who experience unplanned outages, system failures, power fluctuations or outages, or component failures must verify the accuracy of operations performed and data saved or transmitted by the system at or near the time of the outage or failure. In addition, users must establish procedures to ensure that there is independent data verification before relying on such data in sensitive or critical operations. Users should periodically check the manufacturer's support websites for updated information and fixes applicable to the system and related software.

Trademarks

IBM, the IBM logo, and ibm.com are trademarks or registered trademarks of International Business Machines Corp., registered in many jurisdictions worldwide. Other product and service names might be trademarks of IBM or other companies. A current list of IBM trademarks is available on the Web at Copyright and trademark information at www.ibm.com/legal/copytrade.shtml.

Intel, Intel logo, Intel Inside, Intel Inside logo, Intel Centrino, Intel Centrino logo, Celeron, Intel Xeon, Intel SpeedStep, Itanium, and Pentium are trademarks or registered trademarks of Intel Corporation or its subsidiaries in the United States and other countries.

Linux is a registered trademark of Linus Torvalds in the United States, other countries, or both.

Other company, product, or service names may be trademarks or service marks of others.

Electronic emission notices

Class A Notices

The following Class A statements apply to the IBM servers that contain the POWER6 processor.

Federal Communications Commission (FCC) statement

Note: This equipment has been tested and found to comply with the limits for a Class A digital device, pursuant to Part 15 of the FCC Rules. These limits are designed to provide reasonable protection against harmful interference when the equipment is operated in a commercial environment. This equipment generates, uses, and can radiate radio frequency energy and, if not installed and used in accordance with the instruction manual, may cause harmful interference to radio communications. Operation of this

equipment in a residential area is likely to cause harmful interference, in which case the user will be required to correct the interference at his own expense.

Properly shielded and grounded cables and connectors must be used in order to meet FCC emission limits. IBM is not responsible for any radio or television interference caused by using other than recommended cables and connectors or by unauthorized changes or modifications to this equipment. Unauthorized changes or modifications could void the user's authority to operate the equipment.

This device complies with Part 15 of the FCC rules. Operation is subject to the following two conditions: (1) this device may not cause harmful interference, and (2) this device must accept any interference received, including interference that may cause undesired operation.

Industry Canada Compliance Statement

This Class A digital apparatus complies with Canadian ICES-003.

Avis de conformité à la réglementation d'Industrie Canada

Cet appareil numérique de la classe A respecte est conforme à la norme NMB-003 du Canada.

European Community Compliance Statement

This product is in conformity with the protection requirements of EU Council Directive 2004/108/EC on the approximation of the laws of the Member States relating to electromagnetic compatibility. IBM cannot accept responsibility for any failure to satisfy the protection requirements resulting from a non-recommended modification of the product, including the fitting of non-IBM option cards.

This product has been tested and found to comply with the limits for Class A Information Technology Equipment according to European Standard EN 55022. The limits for Class A equipment were derived for commercial and industrial environments to provide reasonable protection against interference with licensed communication equipment.

European Community contact:
IBM Technical Regulations
Pascalstr. 100, Stuttgart, Germany 70569
Tele: 0049 (0)711 785 1176
Fax: 0049 (0)711 785 1283
E-mail: tjahn@de.ibm.com

Warning: This is a Class A product. In a domestic environment, this product may cause radio interference, in which case the user may be required to take adequate measures.

VCCI Statement - Japan

この装置は、クラスA情報技術装置です。この装置を家庭環境で使用すると電波妨害を引き起こすことがあります。この場合には使用者が適切な対策を講ずるよう要求されることがあります。

VCCI-A

The following is a summary of the VCCI Japanese statement in the box above:

This is a Class A product based on the standard of the VCCI Council. If this equipment is used in a domestic environment, radio interference may occur, in which case, the user may be required to take corrective actions.

**Japanese Electronics and Information Technology Industries Association (JEITA)
Confirmed Harmonics Guideline (products less than or equal to 20 A per phase)**

高調波ガイドライン適合品

**Japanese Electronics and Information Technology Industries Association (JEITA)
Confirmed Harmonics Guideline with Modifications (products greater than 20 A per phase)**

高調波ガイドライン準用品

Electromagnetic Interference (EMI) Statement - People's Republic of China

声 明

此为 A 级产品,在生活环境
中,该产品可能会造成无线电干
扰。在这种情况下,可能需要用
户对其干扰采取切实可行的措
施。

Declaration: This is a Class A product. In a domestic environment this product may cause radio interference in which case the user may need to perform practical action.

Electromagnetic Interference (EMI) Statement - Taiwan

警告使用者：

這是甲類的資訊產品，在居住的環境中使用時，可能會造成射頻干擾，在這種情況下，使用者會被要求採取某些適當的對策。

The following is a summary of the EMI Taiwan statement above.

Warning: This is a Class A product. In a domestic environment this product may cause radio interference in which case the user will be required to take adequate measures.

IBM Taiwan Contact Information:

台灣IBM 產品服務聯絡方式：
台灣國際商業機器股份有限公司
台北市松仁路7號3樓
電話：0800-016-888

Electromagnetic Interference (EMI) Statement - Korea

이 기기는 업무용으로 전자파적합등록을 한 기기이오니 판매자 또는 사용자는 이점을 주의하시기 바라며, 만약 잘못 판매 또는 구입하였을 때에는 가정용으로 교환하시기 바랍니다.

Please note that this equipment has obtained EMC registration for commercial use. In the event that it has been mistakenly sold or purchased, please exchange it for equipment certified for home use.

Germany Compliance Statement

Deutschsprachiger EU Hinweis: Hinweis für Geräte der Klasse A EU-Richtlinie zur Elektromagnetischen Verträglichkeit

Dieses Produkt entspricht den Schutzanforderungen der EU-Richtlinie 2004/108/EG zur Angleichung der Rechtsvorschriften über die elektromagnetische Verträglichkeit in den EU-Mitgliedsstaaten und hält die Grenzwerte der EN 55022 Klasse A ein.

Um dieses sicherzustellen, sind die Geräte wie in den Handbüchern beschrieben zu installieren und zu betreiben. Des Weiteren dürfen auch nur von der IBM empfohlene Kabel angeschlossen werden. IBM übernimmt keine Verantwortung für die Einhaltung der Schutzanforderungen, wenn das Produkt ohne Zustimmung der IBM verändert bzw. wenn Erweiterungskomponenten von Fremdherstellern ohne Empfehlung der IBM gesteckt/eingebaut werden.

EN 55022 Klasse A Geräte müssen mit folgendem Warnhinweis versehen werden:

"Warnung: Dieses ist eine Einrichtung der Klasse A. Diese Einrichtung kann im Wohnbereich Funk-Störungen verursachen; in diesem Fall kann vom Betreiber verlangt werden, angemessene Maßnahmen zu ergreifen und dafür aufzukommen."

Deutschland: Einhaltung des Gesetzes über die elektromagnetische Verträglichkeit von Geräten

Dieses Produkt entspricht dem "Gesetz über die elektromagnetische Verträglichkeit von Geräten (EMVG)". Dies ist die Umsetzung der EU-Richtlinie 2004/108/EG in der Bundesrepublik Deutschland.

Zulassungsbescheinigung laut dem Deutschen Gesetz über die elektromagnetische Verträglichkeit von Geräten (EMVG) (bzw. der EMC EG Richtlinie 2004/108/EG) für Geräte der Klasse A.

Dieses Gerät ist berechtigt, in Übereinstimmung mit dem Deutschen EMVG das EG-Konformitätszeichen - CE - zu führen.

Verantwortlich für die Konformitätserklärung nach des EMVG ist die IBM Deutschland GmbH, 70548 Stuttgart.

Generelle Informationen:

Das Gerät erfüllt die Schutzanforderungen nach EN 55024 und EN 55022 Klasse A.

Electromagnetic Interference (EMI) Statement - Russia

ВНИМАНИЕ! Настоящее изделие относится к классу А.
В жилых помещениях оно может создавать радиопомехи, для снижения которых необходимы дополнительные меры

Terms and conditions

Permissions for the use of these publications is granted subject to the following terms and conditions.

Personal Use: You may reproduce these publications for your personal, noncommercial use provided that all proprietary notices are preserved. You may not distribute, display or make derivative works of these publications, or any portion thereof, without the express consent of the manufacturer.

Commercial Use: You may reproduce, distribute and display these publications solely within your enterprise provided that all proprietary notices are preserved. You may not make derivative works of these publications, or reproduce, distribute or display these publications or any portion thereof outside your enterprise, without the express consent of the manufacturer.

Except as expressly granted in this permission, no other permissions, licenses or rights are granted, either express or implied, to the publications or any data, software or other intellectual property contained therein.

The manufacturer reserves the right to withdraw the permissions granted herein whenever, in its discretion, the use of the publications is detrimental to its interest or, as determined by the manufacturer, the above instructions are not being properly followed.

You may not download, export or re-export this information except in full compliance with all applicable laws and regulations, including all United States export laws and regulations.

THE MANUFACTURER MAKES NO GUARANTEE ABOUT THE CONTENT OF THESE PUBLICATIONS. THESE PUBLICATIONS ARE PROVIDED "AS-IS" AND WITHOUT WARRANTY OF ANY KIND, EITHER EXPRESSED OR IMPLIED, INCLUDING BUT NOT LIMITED TO IMPLIED WARRANTIES OF MERCHANTABILITY, NON-INFRINGEMENT, AND FITNESS FOR A PARTICULAR PURPOSE.



Printed in USA