

客户签字确认:

单位: MM

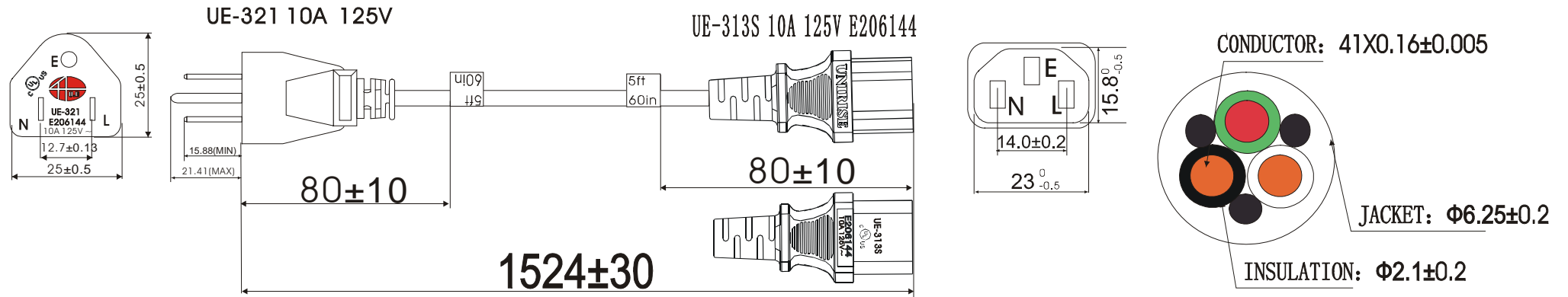

CORD MARKING: E176096 (UL) SVT VW-1 105°C 300V 3x0.824mm² (18AWG) Or
C(UL) SVT FT1 105°C 300V 3x0.824mm² (18AWG) UNIRISE

Technical requirements:

1. Plug: a:5-15P UE-321, Current (A) :10, Voltage (V) :125 Approved: UL
b:C13 UE-313S, Current (A) :10, Voltage (V) :125 Approved: UL
2. Cord: SVT #18/3C 105°C unirise press word RD-20 Approved: UL
3. High Voltage Tested: 1500V/S No Attacked, No Flicker
4. No nick, Spot, Mottle Nn Appearance and Wording is Clearly
5. The All Material Compliance with RoHS and REACH

Standard UE-321+UE-313S / SVT #18/3C 105°C UE/ RD-20

Items	Part Number	Description	quantity
1	315321901	Blade of UE-321 White	1PCS
2	306380220	PVC of plug 38P UE-321 RD-20	/
3	306560220	PVC of plug 60P UE-313S RD-20	/
4	316313903	Connector blade White	1PCS
5	CR91118322-208	SVT 3X18AWG 105°C RD-20	1PCS
6	39005025	47x13mm PET Special sticker	2PCS

Unirise Electric Wire & Cable Co., Ltd.

CHECKED BY		Part number	
Customer	CSA UNIRISE	DRAWING NO	PWCD-515PC13-10A-05F-RED
Applicable product		Sample Part NO	W009-003A-2018
APPROVED BY	liuyingqi	CHECKED BY	songyu
		Drawn by	chengxiewei
			2018-08-23