

# ViewPoint and TouchPoint Accessories



Humanscale® | Better Design,  
HEALTHCARE | Better Care

# Accessory Solutions for ViewPoint and TouchPoint Products

The global leader in healthcare ergonomics, Humanscale Healthcare has identified solutions to optimize the caregiver workflow. The ViewPoint wall stations and TouchPoint mobile technology carts were created to improve the efficiency and effectiveness of caregivers in the non-stop healthcare setting.











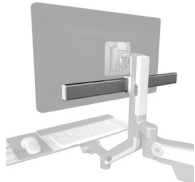
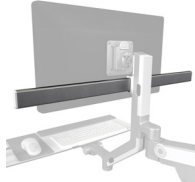
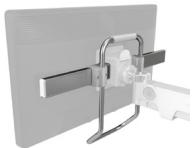
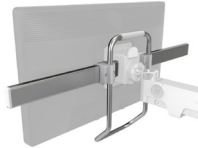

The ViewPoint and TouchPoint accessory lines are designed to further streamline the everyday workflow. Each accessory ensures caregivers are able to balance the demands of interacting with both technology and patients, while also making regularly used items instantly accessible—helping caregivers to prioritize their time more effectively and efficiently.

# ViewPoint V6 Accessories



Humanscale's ViewPoint accessories line optimizes our range of technology wall stations to streamline workflow requirements and enhance caregiver performance. Three mounting options and two rail lengths are available, making the accessories well-suited for nearly any application.



		
<b>V6SHP</b> V6 Standard Healthcare Keyboard Platform	<b>V6VDK</b> V6 V/Desk Keyboard Platform	<b>VPV-19H</b> VESA Accessory Rail Mount with 19" Rail
		
<b>VPV-27vH</b> VESA Accessory Rail Mount with 27" Rail	<b>VPV-19</b> V6 - Accessory Rail Mount with 19" Rail	<b>VPV-27</b> V6 - Accessory Rail Mount with 27" Rail
		
<b>VPA-SC-BKT</b> Rail Mounted Scanner Bracket	<b>VPA-S-CNT</b> Rail Mounted Sharps Container Holder	<b>VPA-GB-HLD</b> Rail Mounted Glove Box Holder
		
<b>VVPA-HD-SNT</b> Rail Mounted Hand Sanitizer Holder	<b>VPA-CH-HLD</b> Rail Mounted Chart Holder	<b>V6TCC</b> V6 Track/Wall Mount CPU Cradle
		
<b>V6WC</b> V6 Wall Mounted Enclosed CPU Holder	<b>V6TC</b> V6 Track Mounted Enclosed CPU Holder	

# ViewPoint Vflex Accessories

		
<p><b>VPS-S27</b> Solo Accessory Rail Mount with 19" Rail</p>	<p><b>VPS-S27</b> Solo Accessory Rail Mount with 27" Rail</p>	<p><b>VPV-19H</b> VESA Accessory Rail Mount with 19" Rail</p>
		
<p><b>VPV-27H</b> VESA Accessory Rail Mount with 27" Rail</p>	<p><b>VPA-SC-BKT</b> Rail Mounted Scanner Bracket</p>	<p><b>VPA-HD-SNT</b> Rail Mounted Hand Sanitizer Holder</p>
		
<p><b>VPA-S-CNT</b> Rail Mounted Sharps Container Holder</p>	<p><b>VPA-GB-HLD</b> Rail Mounted Glove Box Holder</p>	<p><b>V6WC</b> V6 Wall Mounted CPU Holder</p>
		
<p><b>V6TC</b> V6 Track Mounted Enclosed CPU Holder</p>	<p><b>V6TCC</b> V6 Track/Wall Mount CPU Cradle</p>	<p><b>VDK - V6</b> V/Desk for V6</p>
		
<p><b>VDK- VFS</b> Vdesk For Vflex With Short Cable</p>	<p><b>VDK-VFL</b> Vdesk For Vflex With Long Cable</p>	<p><b>VPA-SS</b> ViewPoint Static Accessory Shelf</p>

# ViewPoint VFlex Accessories Continued

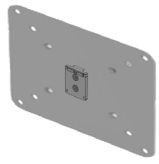
		
<b>VPA-FS</b> ViewPoint Flip-up Accessory Shelf	<b>HCVESA1X2</b> 100 mm x 200 mm VESA Plate	<b>HCVESA2X2</b> 200 mm x 200 mm

	
<b>HCVESA2X4</b> 200 mm x 400 mm	<b>HCVESADD</b> Drop Down VESA Plate

# TouchPoint T7 Accessories

The TouchPoint accessories line was designed with the caregiver workflow in mind. Each accessory is designed to make regularly used items quickly and easily accessible to caregivers.

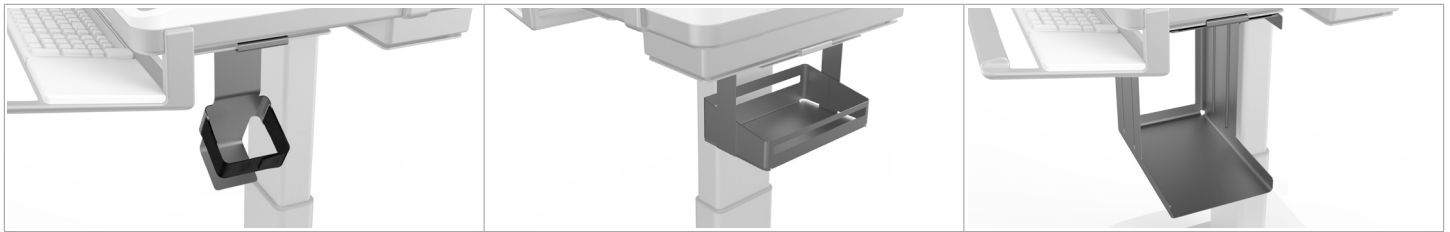

<b>T7-SP-CNTR</b> Sharps Container	<b>T7-U-BSKT</b> Utility Basket	<b>T7-P-SHLF</b> Printer Shelf
---------------------------------------	------------------------------------	-----------------------------------

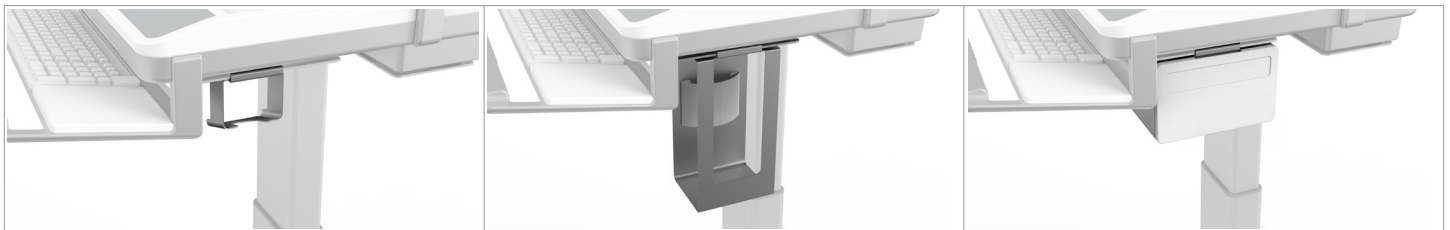

<b>T7-SC-BKT</b> Universal Scanner Bracket	<b>T7-G-B-HLD</b> Glove Box Holder	<b>T7-S-UT-DR</b> Standard Utility Drawer
---	---------------------------------------	--



<b>T7-L-UT-DR</b> Locking Utility Drawer	<b>T7-CPU-HLD</b> T7 CPU Holder	<b>T7-RAR</b> Rear Accessory Rail
---	------------------------------------	--------------------------------------



<b>T7-CB</b> T7 Cross Bar for 2 monitors	<b>TPV-19</b> <b>TPV-27</b> VESA Accessory Rail Mount	<b>T7-AR-SC-MNT</b> T7 Accessory Rail Scanner Mount
---	---	--

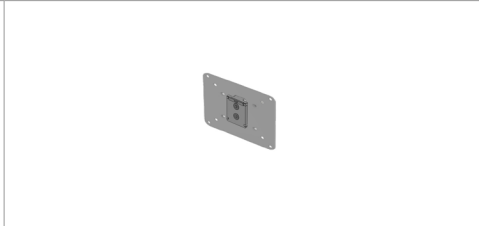
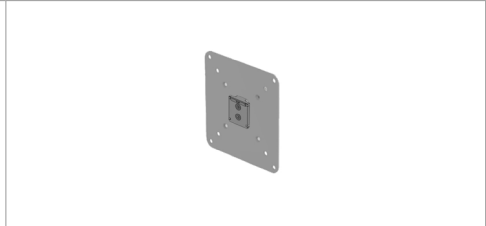

# TouchPoint T7 Accessories Continued

		
<b>T7-C-SC-BK</b> T7 Code Scanner Bracket	<b>HCVESA1X2</b> 3.9" x 7.9" (100 mm x 200 mm) VESA Plate	<b>HCVESA2X2</b> 200 mm x 200 mm

		
<b>HCVESA2X4</b> 7.9" x 15.8" (200 mm x 400 mm)	<b>HCVESADD</b> Drop Down VESA Plate	<b>T7-CAM-MNT</b> T7 Camera Mount

# TouchPoint T7 Storage Drawer Configurations

Expand the T7's storage capacity to make everyday workflows more efficient. The cart saves time and effort for caregivers by storing frequently accessed items within easy reach. The T7 cart can be equipped with up to 5 drawers for easy use and storage. These drawers offer a range of functionality—from single drawers with lock and key security, to 5 individual drawers, each equipped with a digital lock.

		
<p><b>T7-ST-DRW-3</b> Front mounted single drawer with no lock <b>Dimensions (D x W x H):</b> 264 mm X 302 mm X 98 mm 10.30" X 11.80" X 3.80"</p>	<p><b>T7-ST-DRW-2</b> Front mounted three drawers with no lock <b>Dimensions (D x W x H):</b> 264 mm X 302 mm X 98 mm 10.30" X 11.80" X 3.80"</p>	<p><b>T7-ST-DRW-11</b> Front mounted single drawer with key lock <b>Dimensions (D x W x H):</b> 264 mm X 302 mm X 98 mm 10.30" X 11.80" X 3.80"</p>
		
<p><b>T7-ST-DRW-4</b> Front mounted single drawer with electronic keypad lock <b>Dimensions (D x W x H):</b> 242 mm X 302 mm X 98 mm 9.50" X 11.80" X 3.80"</p>	<p><b>T7-ST-DRW-9</b> Front mounted single drawer with electronic keypad lock <b>Dimensions (D x W x H):</b> 280 mm X 200 mm X 75 mm 11.00" X 7.80" X 2.90"</p>	<p><b>T7-ST-DRW-1</b> Front mounted single drawer with electronic keypad lock <b>Dimensions (D x W x H):</b> 264 mm X 302 mm X 218 mm 10.30" X 11.80" X 8.50"</p>
		
<p><b>T7-ST-DRW-5</b> Front mounted two drawers with electronic keypad lock <b>Dimensions (D x W x H):</b> 242 mm X 302 mm X 98 mm 9.50" X 11.80" X 3.80"</p>	<p><b>T7-ST-DRW-8</b> Front mounted two drawers with electronic keypad lock <b>Dimensions (D x W x H):</b> 280 mm X 200 mm X 75 mm 11.00" X 7.80" X 2.90"</p>	<p><b>T7-ST-DRW-6</b> Front mounted two drawers with electronic keypad lock <b>Dimensions (D x W x H):</b> 339 mm X 297 mm X 148 mm 13.30" X 11.60" X 5.80"</p>
		
<p><b>T7-ST-DRW-10</b> Front mounted five drawers with electronic keypad lock <b>Dimensions (D x W x H):</b> (4X) 258 mm X 125 mm X 48 mm 10.10" X 4.90" X 1.80" (1X) 258 mm X 300 mm X 98 mm 10.10" X 11.80" X 3.80"</p>	<p><b>T7-ST-DRW-7</b> Front mounted five drawers with electronic keypad lock <b>Dimensions (D x W x H):</b> (4X) 264 mm X 300 mm X 48 mm 10.30" X 11.80" X 1.80" (1X) 264 mm X 300 mm X 98 mm 10.30" X 11.80" X 3.80"</p>	<p><b>T7-ST-DRW-12</b> Rear mounted single drawer with electronic keypad lock <b>Dimensions (D x W x H):</b> 300 mm X 85 mm X 225 mm 11.81" X 3.35" X 8.86"</p>