

PROLABS – 3CSFP92-C

1.25GBd SFP (Small Form Pluggable) Long Wavelength (1310nm) Transceiver

3CSFP92-C Overview

ProLabs's 3CSFP92-C SFP optical transceivers are based on Gigabit Ethernet IEEE 802.3 standard and Fiber Channel FC-PI Rev.5.0 and provide a quick and reliable interface for the GE/FC application. In addition, they comply with the Small Form Factor Pluggable Multi Sourcing Agreement (MSA).

Product Features

- Up to 1.25 GBd bi-directional data links
- Compliant with IEEE 802.3z Gigabit Ethernet and 1000BASE-LX
- Compliant with SFP MSA
- Hot-pluggable SFP footprint
- 1310nm Fabry-Perot laser transmitter
- Duplex LC connector
- Up to 10-20km on 9/125um SMF
- Single power supply 3.3V
- RoHS Compliance
- Class 1 laser product complies with EN 60825-1
- Operating temperature range: 0°C to 70°C.

Applications

- 1.25 GBd Gigabit Ethernet
- 1.063 GBd Fiber Channel
- Compatible with 3CSFP92

Ordering Information

| Part Number | Description |
|--------------------|---|
| 3CSFP92-C | GE/FC SFP 1310nm LC Connectors 10km on SMF. |

General Specifications

| Parameter | Symbol | Min | Typ | Max | Unit | Remarks |
|-----------------------|------------------------|------------|------------|------------|-------------|--------------------------------|
| Data Rate | <i>DR</i> | | 1.25 | | GBd | IEEE 802.3 |
| | | | 1.062 | | | FC-PI-2 Rev 5 |
| Bit Error Rate | <i>BER</i> | | | 10^{-12} | | |
| Operating Temperature | <i>T_{OP}</i> | 0 | | 70 | °C | Case temperature |
| Storage Temperature | <i>T_{STO}</i> | - 40 | | 85 | °C | Ambient temperature |
| Supply Current | <i>I_S</i> | | 175 | 300 | mA | For electrical power interface |
| Input Voltage | <i>V_{CC}</i> | 3 | 3.3 | 3.6 | V | |
| Maximum Voltage | <i>V_{MAX}</i> | - 0.5 | | 4 | V | For electrical power interface |

Optical Characteristics – Transmitter

$V_{CC}=3V$ to $3.6V$, $T_C=0^{\circ}C$ to $70^{\circ}C$

| Parameter | Symbol | Min | Typ | Max | Unit | Remarks |
|------------------------------------|------------------|-------|-----|-------|-------|--|
| Output Optical Power | P_{TX} | - 9.5 | | - 3 | dBm | Class 1 Product |
| Optical Center Wavelength | λ_C | 1270 | | 1360 | nm | |
| Optical Modulation Amplitude | OMA | 174 | | | uW | Equivalent extinction ratio specification for FC |
| Extinction Ratio | ER | 9 | | | dB | |
| Spectral Width (RMS) | $\Delta\lambda$ | | | 3 | nm | |
| Optical Rise/Fall Time (20% - 80%) | T_{RF_IN} | | 150 | 260 | ps | |
| Relative Intensity Noise | RIN | | | - 120 | dB/Hz | |
| Deterministic Jitter Contribution | $TX_ \Delta DJ$ | | 20 | 56.5 | ps | |
| Total Jitter Contribution | $TX_ \Delta TJ$ | | 50 | 119 | ps | |

Optical Characteristics – Receiver

$V_{CC}=3V$ to $3.6V$, $T_C=0^{\circ}C$ to $70^{\circ}C$

| Parameter | Symbol | Min | Typ | Max | Unit | Remarks |
|--|---------------|------|-----|--------|------|---------------|
| Optical Receiver Power | P_{RX} | | | 0 | dBm | Average |
| Optical Center Wavelength | λ_C | 1265 | | 1600 | nm | |
| Receiver Sensitivity @ 1.063GBd | R_{X_SEN1} | | | - 21 | dBm | FC-PI-2 Rev.5 |
| Receiver Sensitivity @ 1.25GBd | R_{X_SEN2} | | | - 19 | dBm | IEEE 802.3 |
| Stressed Rx Sens @ 1.25GBd | | | | - 14.5 | dBm | IEEE 802.3 |
| Optical Return Loss | ORL | 12 | | | dB | |
| Receiver Electrical 3dB Upper cutoff frequency | | | | 1500 | MHz | |
| Loss of Signal-Asserted | P_{LOS_A} | - 30 | | | dBm | |
| Loss of Signal-Deasserted | P_{LOS_D} | | | - 19 | dBm | |
| Loss of Signal-Hysteresis | | 0.5 | | | dB | |

Electrical Characteristics – Transmitter

$V_{CC}=3V$ to $3.6V$, $T_C=0^{\circ}C$ to $70^{\circ}C$

| Parameter | Symbol | Min | Typ | Max | Unit | Remarks |
|-------------------------------|--------------|--------------|-----|--------------|----------|----------------|
| Input differential impedance | R_{IN} | | 100 | | Ω | Non condensing |
| Single ended data input swing | V_{IN_PP} | 250 | | 1200 | mV | |
| Transmit disable voltage | V_D | $V_{CC}-1.3$ | | V_{CC} | V | |
| Transmit enable voltage | V_{EN} | V_{EE} | | $V_{EE}+0.8$ | V | |
| Transmit disable assert time | | | | 10 | us | |

Electrical Characteristics – Receiver

$V_{CC}=3V$ to $3.6V$, $T_C=0^{\circ}C$ to $70^{\circ}C$

| Parameter | Symbol | Min | Typ | Max | Unit | Remarks |
|--------------------------------------|-------------------|--------------|-----|------------------|------------------|---------|
| Single ended data output swing | V_{OUT_PP} | 300 | 400 | 800 | mV | |
| Data output rise/fall time (20%-80%) | T_R | | | 300 | ps | |
| LOS Fault | V_{LOS_Fault} | $V_{CC}-0.5$ | | $V_{CC_HO_ST}$ | V | |
| LOS Normal | V_{LOS_normal} | V_{EE} | | $V_{EE}+0.5$ | V | |
| Power Supply Rejection | PSR | 100 | | | mV _{PP} | |
| Deterministic Jitter Contribution | $RX_ \Delta DJ$ | | | 80 | ps | |
| Total Jitter Contribution | $RX_ \Delta TJ$ | | | 122.4 | ps | |

Block Diagram of Transceiver

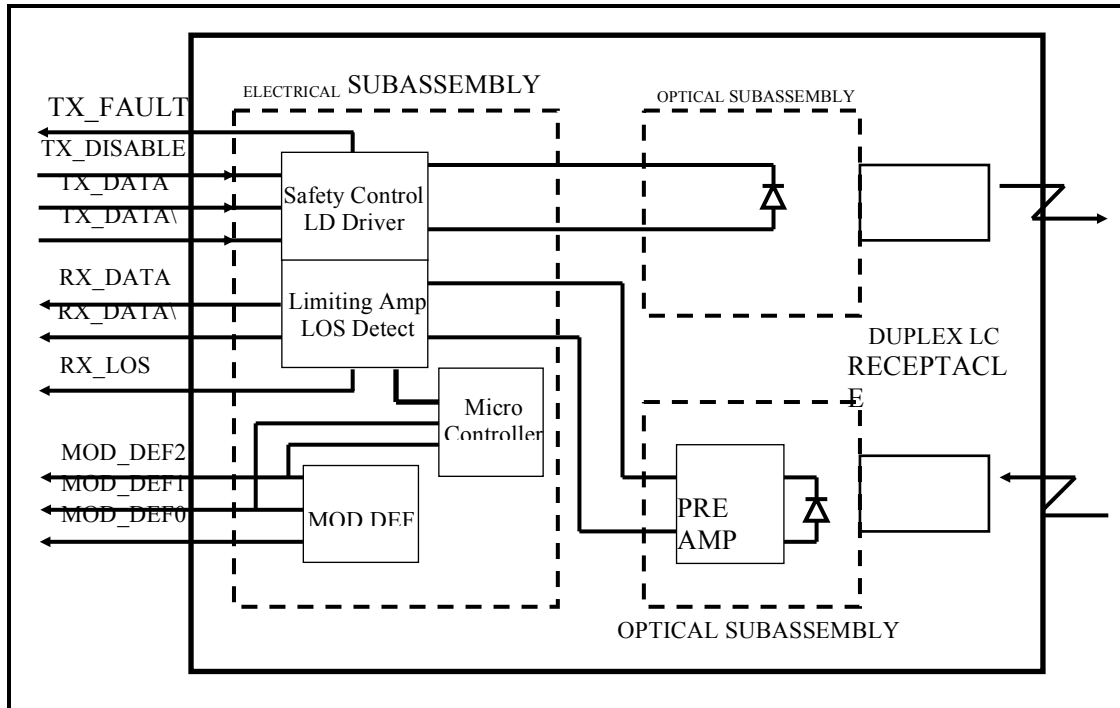

Transmitter Section

The FP driver accept differential input data and provide bias and modulation currents for driving a laser. An automatic power-control (APC) feedback loop is incorporated to maintain a constant average optical power. 1310 nm FP in an eye safe optical subassembly (OSA) mates to the fiber cable.

TX_DISABLE

The TX_DISABLE signal is high (TTL logic "1") to turn off the laser output. The laser will turn on within 1ms when TX_DISABLE is low (TTL logic "0").

TX_FAULT

When the TX_FAULT signal is high, output indicates a laser fault of some kind. Low indicates normal operation.

Receiver Section

The receiver utilizes a PIN detector integrated with a trans-impedance preamplifier in an OSA. This OSA is connected to a Limiting Amplifier which providing post-amplification quantization, and optical signal detection. The limiting Amplifier is AC-coupled to the transimpedance amplifier, with internal 100Ω differential termination.

Receive Loss (RX_LOS)

The RX_LOS is high (logic "1") when there is no incoming light from the companion transceiver. This signal is normally used by the system for the diagnostic purpose. The signal is operated in TTL level.

Controller Section

The micro controller unit monitors the operation information of LD driver and Limiting Amplifier. And report these status to the customer.

Dimensions

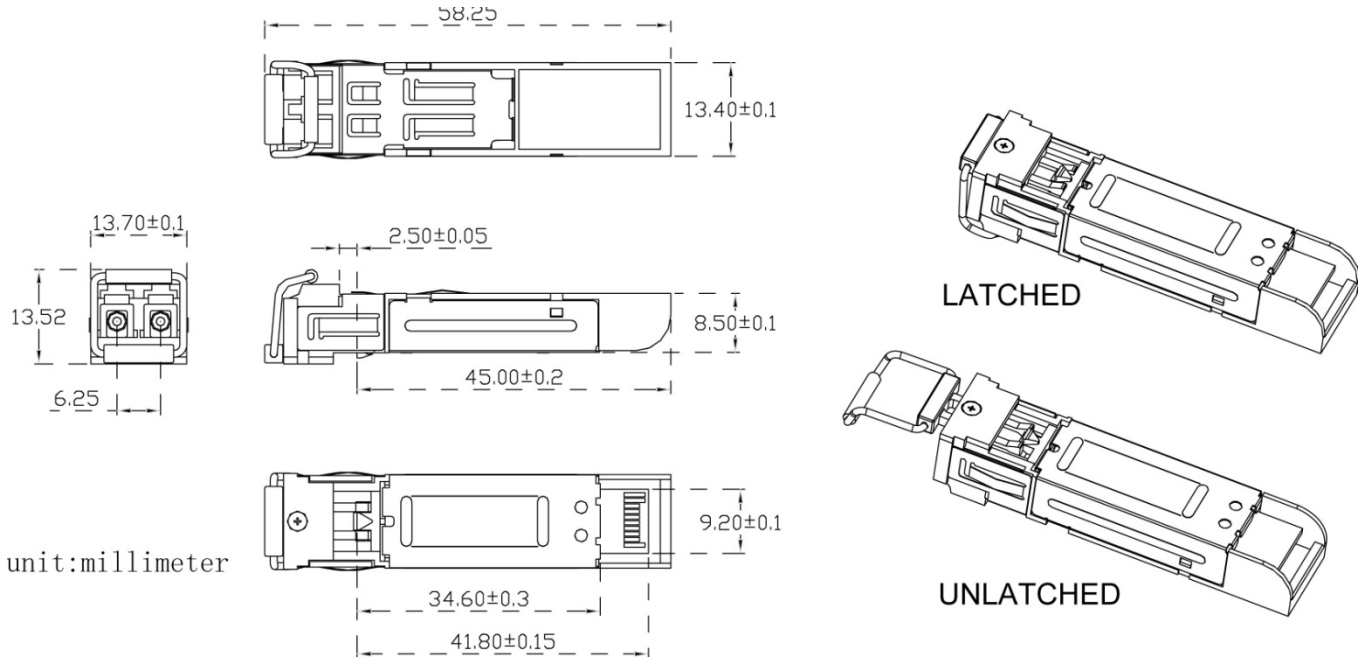

**ALL DIMENSIONS ARE ±0.2mm UNLESS OTHERWISE SPECIFIED
UNIT: mm**

PCB Layout Recommendation

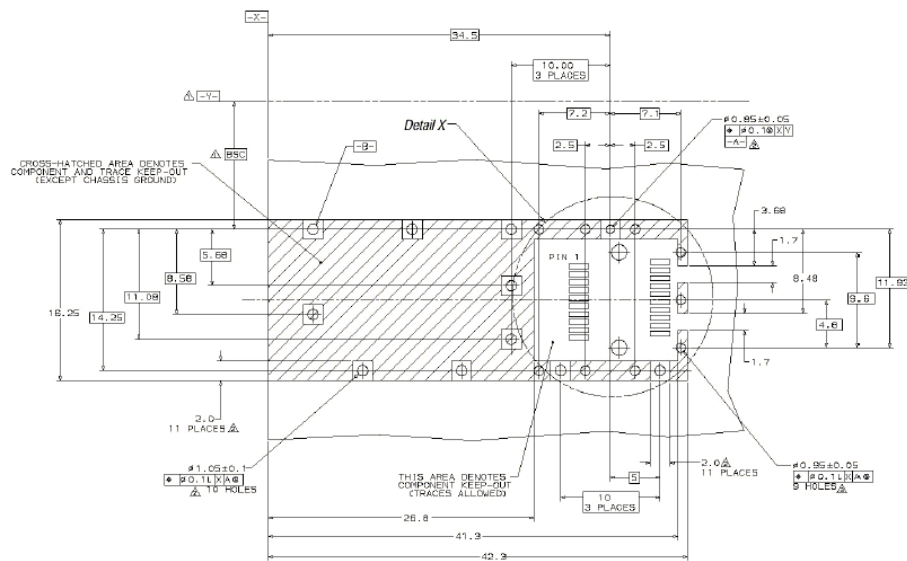

Δ Datum and Basic Dimension Established by Customer

Δ Pads and Vias are Chassis Ground, 11 Places

Δ Through Holes are Unplated

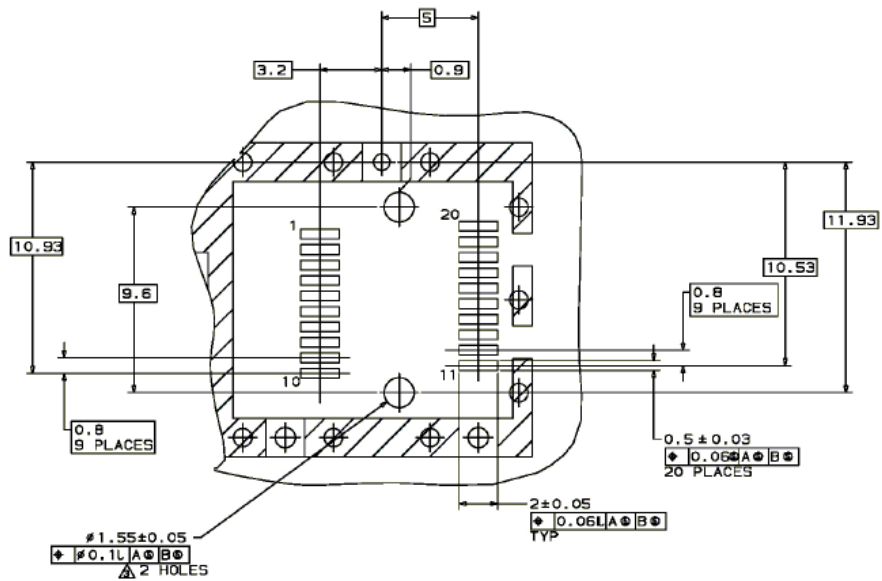

Pin Assignment

| PIN # | Symbol | Description | Remarks |
|--------------|--------------------|---|--|
| 1 | V _{EET} | Transmitter ground (common with receiver ground) | Circuit ground is isolated from chassis ground |
| 2 | T _{FAULT} | Transmitter Fault. Not supported | |
| 3 | T _{DIS} | Transmitter Disable. Laser output disable on high or open | Disabled: T _{DIS} >2V or open Enabled: T _{DIS} <0.8V |
| 4 | MOD_DEF (2) | Module Definition 2. Data line for serial ID | Should Be pulled up with 4.7k – 10k ohm on host board to a voltage between 2V and 3.6V |
| 5 | MOD_DEF (1) | Module Definition 1. Clock line for serial ID | |
| 6 | MOD_DEF (0) | Module Definition 0. Grounded within the module | |
| 7 | Rate Select | No connection required | |
| 8 | LOS | Loss of Signal indication. Logic 0 indicates normal operation | LOS is open collector output |
| 9 | V _{EER} | Receiver ground (common with transmitter ground) | Circuit ground is isolated from chassis ground |
| 10 | V _{EER} | Receiver ground (common with transmitter ground) | |
| 11 | V _{EER} | Receiver ground (common with transmitter ground) | |
| 12 | RD- | Receiver Inverted DATA out. AC coupled | |
| 13 | RD+ | Receiver Non-inverted DATA out. AC coupled | |
| 14 | V _{EER} | Receiver ground (common with transmitter ground) | Circuit ground is isolated from chassis ground |
| 15 | V _{CCR} | Receiver power supply | |
| 16 | V _{CCT} | Transmitter power supply | |
| 17 | V _{EET} | Transmitter ground (common with receiver ground) | Circuit ground is connected to chassis ground |
| 18 | TD+ | Transmitter Non-Inverted DATA in. AC coupled | |
| 19 | TD- | Transmitter Inverted DATA in. AC coupled | |
| 20 | V _{EET} | Transmitter ground (common with receiver ground) | Circuit ground is connected to chassis ground |

References

1. IEEE standard 802.3. IEEE Standard Department, 2002.
2. Small Form Factor Pluggable (SFP) Transceiver Multi-Source Agreement (MSA), September 2000.
3. Fiber Channel Draft Physical Interface Specification (FC-PI-2 Rev.5).
4. Fiber Channel Physical and Signaling Interface (FC-PH/PH2/PH3).