

**HM 31 AA E**  
**KM 31 AA E**  
**HM 31 AA E C 03**

**GB**

English

# **Operating Instructions**

## **REFRIGERATOR/FREEZER COMBINATION**

### **Contents**

Operating Instructions, 1  
Assistance, 2  
Description of the appliance, 3  
Energy Saving, 3  
Description of the appliance, 4  
Installation, 5  
Start-up and use, 6  
Maintenance and care, 7  
Precautions and tips, 8  
Troubleshooting, 9

**Register your  
appliance now on  
08448 24 24 24**

## Assistance

### Guarantee

#### 12 months Parts and Labour Guarantee

Your appliance has the benefit of our manufacturer's guarantee, which covers the cost of breakdown repairs for twelve months from the date of purchase.

This gives you the reassurance that if, within that time, your appliance is proven to be defective because of either workmanship or materials, we will, at our discretion, either repair or replace the appliance at no cost to you.

This guarantee is subject to the following conditions:

- The appliance has been installed and operated correctly and in accordance with our operating and maintenance instructions.
- The appliance is used only on the electricity or gas supply printed on the rating plate.
- The appliance has been used for normal domestic purposes only.
- The appliance has not been altered, serviced, maintained, dismantled, or otherwise interfered with by any person not authorised by us.
- Any repair work must be undertaken by us or our appointed agent.
- Any parts removed during repair work or any appliance that is replaced become our property.
- The appliance is used in the United Kingdom or Republic of Ireland.

The guarantee does not cover:

- Damage resulting from transportation, improper use, neglect or interference or as a result of improper installation.
- Replacement of any consumable item or accessory. These included but not limited to: plugs, cables, batteries, light bulbs, fluorescent tubes and starters, covers and filters.
- Replacement of any removable parts made of glass or plastic.

THIS GUARANTEE WILL NOT APPLY IF THE APPLIANCE HAS BEEN USED IN COMMERCIAL OR NON-DOMESTIC PREMISES.

#### 5 Year Parts Guarantee

Hotpoint also offers you a free 5 year parts guarantee. This additional guarantee is conditional on you registering your appliance with us and the parts being fitted by one of our authorised engineers. There will be a charge for our engineer's time. To activate the extra parts warranty on your appliance, simply call our registration line on **08448 242424 (Republic of Ireland 01 230 0233)**.

#### Extended Guarantees

We offer a selection of protection plans that enable you to fully cover yourself against the expense of repair bills for the life of your policy. To find the ideal plan for you please call our advice line on **08448 226 226 (Republic of Ireland 01 230 0233)**.

#### Helpdesk Service

We have a dedicated team who can provide free advice and assistance with your appliance if you experience any technical difficulties within the first 90 days of ownership. Simply call our Hotpoint Service Hotline on **08448 224 224 (Republic of Ireland 0818 313 413)** for telephone assistance, or, where necessary, to arrange for an engineer to call.

## After Sales Service

We pride ourselves on ensuring that you and your Hotpoint appliance receive the very highest level of service. No one understands Hotpoint appliances like we do, so for service from the people that know your appliance best, simply call 08448 224 224. Our operators are on hand to answer your call every day including weekends and bank holidays.

Our team of 1000 technicians are the largest white goods service organisation in the UK and Ireland available to provide fast, reliable and local service. They have all undergone extensive training at our Training Centre of Excellence and are equipped with the latest diagnostic tools to deliver expert servicing of your Hotpoint appliance.

**UK: 08448 224 224**  
**Republic of Ireland: 0818 313 413**

or visit  
**www.hotpointservice.co.uk**

Model number: \_\_\_\_\_

Serial number: \_\_\_\_\_

### Parts and Accessories

We supply a full range of genuine replacement parts as well as accessory products that protect and hygienically clean your appliance to keep it looking good and functioning efficiently throughout its life.

**UK: 08448 225 225**  
**Republic of Ireland: 0818 313 413**

or visit  
**www.hotpointservice.co.uk**

### Appliance Registration

We want to give you additional benefits of Hotpoint ownership. To activate your free 5 year parts guarantee you must register your appliance.

By registering your appliance with us not only do you do you activate the guarantee all your information will be logged onto our repair system. In the unfortunate event that you need assistance we will have your appliance details to hand when you call us.

**UK: 08448 24 24 24**  
**Republic of Ireland: 01 230 0800**

or visit  
**www.hotpointservice.co.uk**

**Indesit Company UK Ltd. Morley Way, Peterborough, PE2 9JB**  
Indesit Ireland Ltd. The Crescent Building, Northwood Park, Santry, Dublin 9.

### Recycling and Disposal Information

As part of Hotpoint's continued commitment to helping the environment, Hotpoint reserves the right to use quality, recycled components to keep down customer costs and minimise material wastage.

Please dispose of packaging and old appliances carefully. To minimise the risk of injury to children, remove the door, plug, and cut the mains cable off flush with the appliance. Dispose of these parts separately to ensure that the appliance can no longer be plugged into mains socket, and the door cannot be locked shut.

**GB** - model

**GB** - serial number

Mod. <b>RG 2330</b>		TI		Cod. <b>93139180000</b>		S/N <b>704211801</b>	
240 V~	Hz	150 W	W	Fuse	A	Max 15	
Total	340	75			Freez.	Capac	Class
Gross Bruto		Gross Bruto	Net Util	Gross Bruto	Poder de Cong	kg/24 h	4,0
Bruto		Bruto	Utilite	Bruto	Classe		<b>N</b>
Compr. Syst.	R 134 a	Test	Pressure				Classe
Kompr.	kg 0,090	P.S-I	HIGH-235				
Made in Italy			13918				

**GB**

## Description of the appliance

### Control panel

#### 1. ON/OFF

The entire product (both the refrigerator and freezer compartments) may be switched on by pressing this button. The indicator light  indicates that the product is off, even if it is still receiving power. Once the product has been switched on, this indicator light will no longer be visible.

#### 2. REFRIGERATOR - and + temperature adjustment

Used to modify the temperature setting of the refrigerator; confirmation corresponding to the selected temperature appears on the display.

#### 3. Refrigerator display

Shows the set temperature for the refrigerator compartment.

#### 4. FREEZER TEMPERATURE ALARM

The temperature of the freezer has exceeded the safety threshold for optimal food storage (see Troubleshooting section)

#### 5. DOOR OPEN ALARM

The refrigerator door has been open for more than two minutes (see Troubleshooting section)

#### 6. FREEZER - and + temperature adjustment

Used to modify the temperature setting of the freezer; confirmation corresponding to the selected temperature appears on the display.

#### 7. FREEZER display

Shows the set temperature for the freezer compartment.

#### 8. SPEED COOL

Activates or deactivates the SPEED COOL function (rapid cooling).  will appear on the display .

#### 9. SUPER FREEZE

Activates or deactivates the SUPER FREEZE function (rapid freezing).  will appear on the display .

#### 10. HOLIDAY

Activates or deactivates the HOLIDAY function (the HOLIDAY LED on the keypad lights up), while the temperature values +12°C and -18°C appear on the refrigerator and freezer displays respectively. Ten minutes after the most recent user interaction, the display enters its energy saving mode

**GB**

## Energy Saving function

The Energy Saving function can be activated to optimise energy consumption while maintaining the cooling performance of the product. This function maximises the amount of energy saved. Under these conditions, the display remains off even when the door is opened. The function is activated by pressing and holding the super freezer and FRZ (+) buttons simultaneously for at least 6 seconds. Once the function has been activated, all LEDs will light up for 2 seconds to confirm activation, and the temperature setting of +5, -18 will appear on the display. The display switches off after 5 seconds. To change the temperature, simply press the + and - buttons until you have reached the desired temperature.

However, the Energy Saving function can also be disabled by switching the product off using the ON/OFF button. When it is switched back on, the Energy Saving will be disabled.

In humid environments, when the Energy Saving function is enabled, slight condensation may form on the appliance door; normal operating conditions are restored when the function is disabled.

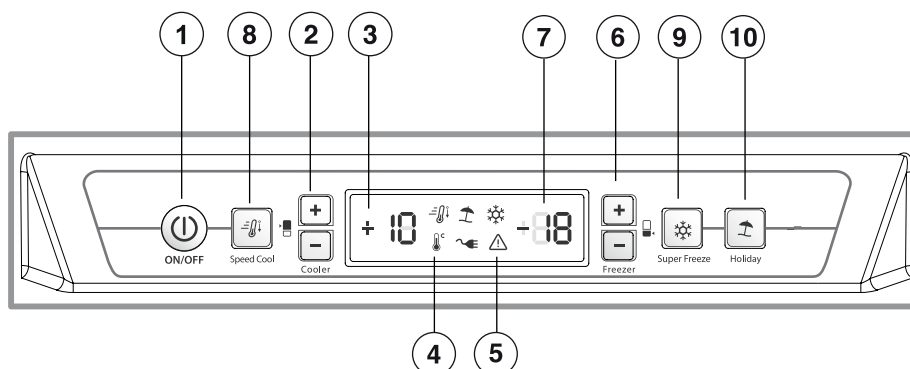

# Description of the appliance

## Overall view

The instructions contained in this manual are applicable to different model refrigerators. The diagrams may not directly represent the appliance purchased. For more complex features, consult the following pages.

- 1 **STORAGE** compartment \*
- 2 **FREEZER** and **STORAGE** compartment
- 3 **FRUIT** and **VEGETABLE** bin \*
- 4 **Food Care Zone / Food Care Zone 0°C / Safe Defrost\***
- 5 **WINE RACK** \*
- 6 **SHELVES** \*
- 7 **LAMP** (see Maintenance). \*
- 8 Removable multipurpose **SHELVES** \*
- 9 **BOTTLE** shelf
- 10 **FRESH BOX** \*
- 11 **ACTIVE OXYGEN** \*
- 12 **AIR** \*

\* Varies by number and/or position, available only on certain models.

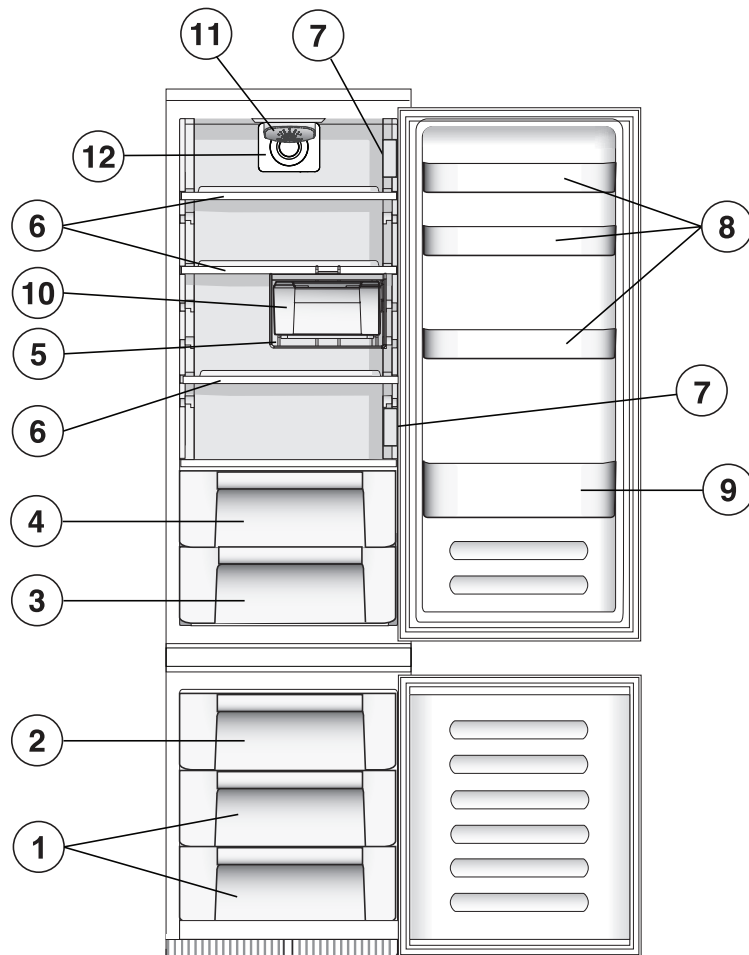

## Installation

! Before placing your new appliance into operation please read these operating instructions carefully. They contain important information for safe use, for installation and for care of the appliance.

! Please keep these operating instructions for future reference. Pass them on to possible new owners of the appliance.

### Positioning and connection

#### Positioning

1. Place the appliance in a well-ventilated humidity-free room.
2. Do not obstruct the rear fan grills. The compressor and condenser give off heat and require good ventilation to operate correctly and save energy.
3. Ensure the appliance is away from any sources of heat (direct sunlight, electric stove, etc.).

#### Electrical connections

After the appliance has been transported, carefully place it vertically and wait at least 3 hours before connecting it to the electricity mains. Before inserting the plug into the electrical socket ensure the following:

- The appliance is earthed and the plug is compliant with the law.
- The socket can withstand the maximum power of the appliance, which is indicated on the data plate located on the bottom left side of the fridge (e.g. 150 W).
- The voltage must be in the range between the values indicated on the data plate located on the bottom left side (e.g. 220-240V).
- The socket is compatible with the plug of the appliance. If the socket is incompatible with the plug, ask an authorised technician to replace it (see Assistance). Do not use extension cords or multiple sockets.

! Once the appliance has been installed, the power supply cable and the electrical socket must be easily accessible.

! The cable must not be bent or compressed.

! The cable must be checked regularly and replaced by authorised technicians only (see Assistance).

! The manufacturer declines any liability should these safety measures not be observed.

#### WARNING:

**THIS APPLIANCE MUST BE EARTHED.**

#### Replacing fuse covers:

When replacing a faulty fuse, a 13amp ASTA approved fuse to BS 1362 should always be used and the fuse cover re-fitted.

If the fuse cover is lost, the plug must not be used until a replacement is obtained.

#### Replacement fuse covers:

If a replacement fuse cover is fitted, it must be of the correct colour as indicated by the coloured marking or the colour that is embossed in words on the base of the plug.

### Changing the plug:

#### Removing the plug

If your appliance has a non-rewireable moulded plug and you should wish to remove it to add a longer cable or to re-route the mains cable through partitions, units etc. please ensure that either:

- The plug is replaced by a fused 13amp re-wireable plug bearing the BSI mark of approval.

or

- The mains cable is wired directly into a 13amp cable outlet, controlled by a switch (in compliance with BS 5733) which is accessible without moving the appliance.

#### Disposing of the plug

Cut off and dispose of the supplied plug if it does not fit your socket. The cable should be cut as close as possible to the moulded plug.

#### Remove the fuse.

#### WARNING:

**To avoid a shock hazard do not insert the discarded plug into a socket anywhere else.**

#### Fitting a new plug

#### IMPORTANT:

WIRES IN THE MAINS LEAD ARE COLOURED IN ACCORDANCE WITH THE FOLLOWING CODE...

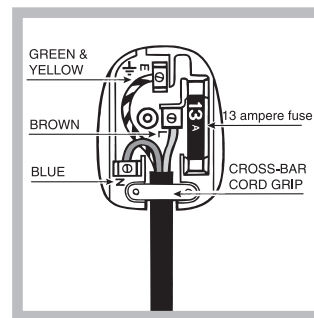

- Green and Yellow - Earth
- Blue - Neutral
- Brown - Live

As the colours of the wires in the mains lead may not correspond with the coloured markings identifying the terminals in your plug, proceed as follows:

- Connect **Green and Yellow** wire to terminal marked 'E' or or coloured Green and Yellow.
- Connect **Brown** wire to terminal marked 'L' or coloured red or brown.
- Connect **Blue** wire to terminal marked 'N' or coloured Black or Blue.

If a 13amp plug (BS 1363) is used it must be fitted with a 13amp fuse.

**If you are in any doubt about the electrical supply to your machine, consult a qualified electrician before use.**

**CE Marking certifies that this appliance conforms to the following EEC directives:**

**Low Voltage Equipment - 73/23/EEC & 93/68 EEC**

**Electromagnetic Compatibility 89/336/EEC, 92/31/EEC & 93/68/EEC**

## Start-up and use

### Starting the appliance

! Before starting the appliance, follow the installation instructions (see Installation).

! Before connecting the appliance, clean the compartments and accessories well with lukewarm water and bicarbonate.

! The appliance comes with a motor protection control system which makes the compressor start approximately 8 minutes after being switched on. The compressor also starts each time the power supply is cut off whether voluntarily or involuntarily (blackout).

### Freezer Compartment

When the product is switched on the freezer compartment is set to its default value of  $-18^{\circ}\text{C}$ . We recommend that the SUPER FREEZE function is set (the freezer status bar continues to display the set value) in order to accelerate the cooling process of the compartment; when the inside of the compartment has reached its optimal temperature the function will be deactivated and the food may be placed inside.

### Refrigerator Compartment

When the appliance is switched on the refrigerator compartment is set to its default value of  $+5^{\circ}\text{C}$ . We recommend that the SPEED COOL function is set (the refrigerator status bar continues to display the set value) in order to accelerate the cooling process of the compartment. After a few hours it will be cool enough for food to be placed inside.

## Navigating the display

### Setting the temperatures:

If the product is switched on, the refrigerator and freezer compartment displays will indicate the temperature values set at that moment. To change them, simply press the **-** and **+** buttons corresponding to the compartment for which you wish to change the set temperature. More specifically, each time the buttons are pressed, the temperature increases or decreases and the level of cold generated inside the compartment is adjusted accordingly. The temperature values that may be selected for the refrigerator compartment are  $+8^{\circ}\text{C}$ ,  $+7^{\circ}\text{C}$ ,  $+6^{\circ}\text{C}$ ,  $+5^{\circ}\text{C}$ ,  $+4^{\circ}\text{C}$ ,  $+3^{\circ}\text{C}$  and  $+2^{\circ}\text{C}$ , while the values that may be set for the freezer are  $-18^{\circ}\text{C}$ ,  $-19^{\circ}\text{C}$ ,  $-20^{\circ}\text{C}$ ,  $-21^{\circ}\text{C}$ ,  $-22^{\circ}\text{C}$ ,  $-24^{\circ}\text{C}$  and  $-26^{\circ}\text{C}$ .

When the **HOLIDAY** function is active the temperature may not be adjusted, however the appliance adjusts itself automatically so that the optimal settings for the situation are used:  **$+12^{\circ}\text{C}$**  for the refrigerator compartment and  **$-18^{\circ}\text{C}$**  for the freezer compartment. The activation of this function is indicated by the **HOLIDAY** LED lighting up.

To activate and deactivate the functions, simply press the relevant button; the function status will be signalled by the corresponding LED on the keypad switching on or off.

Several of the functions (**SPEED COOL**, **SUPER FREEZE**) are incompatible with others (**HOLIDAY**,...); remember that there is a pre-established order of priority which will help you to operate the product in the best possible way.

### AIR \*

It is recognizable due to the presence of the mechanism on the top part of the refrigerator compartment (see diagram).

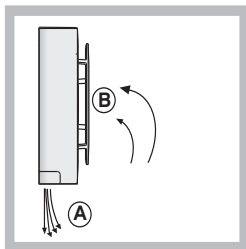

**AIR** maximises air circulation, improving the efficiency of the evaporator and helping to achieve the optimal temperature inside the refrigerator as quickly as possible each time it has been opened. The blown air (A) is cooled when it comes into contact with the cold wall, whereas the hotter air (B) is sucked up (see diagram).

### ACTIVE OXYGEN \*

This device releases ozone molecules inside the refrigerator; ozone is a natural substance which combats bacteria and

\* Varies by number and/or position, available only on certain models.

microorganisms, reducing their proliferation while limiting unpleasant odours.

Automatically defines the amount of ozone required for prolonging the freshness of foodstuffs, eliminating odours and preventing bacteria build-up.

There may be a slight distinctive odour inside the refrigerator. The very same smell can sometimes be detected during a storm, due to the ozone produced as the charge in the lightning bolts is released; this is completely normal. The amount produced by the device is very small and abates quickly as the antibacterial action takes place.

Device is activated pressing the dedicated switch located in right side of the Oxygen device.



With the Active Oxygen switched on, the device will operate a repeated cycle until the key is pressed again. There will be an Ozone emission noticed by the switching on of the green led located on the Active Oxygen device located in the fridge compartment and a stand-by cycle (without ozone emission) noticed by blue light.

## Using the refrigerator to its full potential

- Adjust the temperature using the display.
- Activate the SPEED COOL function to lower the temperature quickly, for example, when you place a large number of new food items inside a fridge and the internal temperature rises slightly. This function quickly cools the groceries by temporarily reducing the temperature until it reaches the ideal level.
- Place only cold or lukewarm foods in the compartment, never hot foods (see Precautions and tips).
- Remember that cooked foods do not last longer than raw foods.
- Do not store liquids in open containers: they will increase the level of humidity in the refrigerator and cause condensation to form.

### SHELVES: with or without grill.

Due to the special guides the shelves are removable and the height is adjustable (see diagram), allowing easy storage of large containers and food. Height can be adjusted without complete removal of the shelf.

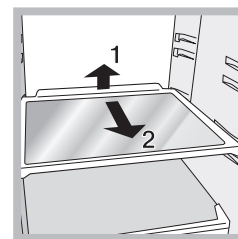

### Food Care Zone \*

Area dedicated to the storage of fresh food, such as meat and fish. Thanks to the low temperature inside the compartment, the Food Care Zone extends the period of time for which the food can be stored, keeping it fresh for up to a week.

**Food Care Zone  $0^{\circ}\text{C}$  / Safe Defrost\*** : A compartment designed to keep delicate food such as meat and fish fresh. The low temperature in the compartment makes it possible to store the food



for up to one week - tests performed on meat products - without changing its nutrients, appearance and flavour.

The compartment is also very suitable for healthy food defrosting, as low-temperature defrosting prevents any proliferation of microorganisms, while protecting its taste and organoleptic properties.

It is not suitable for fruit, vegetables and green salad. But it can be used for fresh or very fresh dairy products and milk, stuffed fresh pasta and even cooked food or leftovers..

#### FRESH BOX \*

This is the new container, designed to keep various foods (such as cheese and cold meats) fresher for longer. If it is not needed, it can easily be removed from the refrigerator compartment. If there is a Bottle Shelf, more internal space can be created by placing the Fresh Box directly inside it.

**TEMPERATURE Indicator light\***: to identify the coldest area in the refrigerator.

1. Check that OK appears clearly on the indicator light (see diagram).



2. If the word "OK" does not appear it means that the temperature is too high: adjust the REFRIGERATOR OPERATION knob to a higher position (colder) and wait approximately 10 hours until the temperature has been stabilised.
3. Check the indicator light again: if necessary, readjust it following the initial process. If large quantities of food have been added or if the refrigerator door has been opened frequently, it is normal for the indicator not to show OK. Wait at least 10 hours before adjusting the REFRIGERATOR OPERATION knob to a higher setting.

#### LED \*

Thanks to the powerful light it emits, the new LED lighting system offers a clear view of all foods, with no shadowy areas. If the LED needs to be replaced, please contact the Technical Assistance Service.

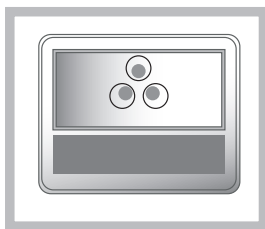

### Using the freezer to its full potential

- Adjust the temperature using the display.
- Fresh food that needs to be frozen must not come into contact with food that has already been defrosted. Fresh food must be stored in the top FREEZER and STORAGE compartment where the temperature drops below -18°C and guarantees rapid freezing.
- To freeze fresh food in the best and safest way possible, activate the SUPER FREEZE function 24 hours before placing the food in the freezer. After placing the food inside, activate the SUPER FREEZE function again; it will be deactivated automatically after 24 hours.
- Do not re-freeze food that is defrosting or that has already

\* Varies by number and/or position, available only on certain models.

been defrosted. These foods must be cooked and eaten (within 24 hours).

- Do not place glass bottles which contain liquids, and which are corked or hermetically sealed in the freezer because they could break.
- The maximum quantity of food that may be frozen daily is indicated on the plate containing the technical properties located on the bottom left side of the refrigerator compartment (for example: Kg/24h: 4).

! Do not open the door during freezing.

! If there is a power cut or malfunction, do not open the freezer door. This will help maintain the temperature inside the freezer, ensuring that foods are conserved for at least 9 -14 hours.

! In order to obtain a greater amount of space in the freezer compartment, you may remove the bins (with the exception of the bottom drawer) and place the food directly onto the evaporator plates.

## Maintenance and care

### Switching the appliance off

During cleaning and maintenance it is necessary to disconnect the appliance from the electricity supply:

1. Press the ON/OFF button to switch off the appliance.
2. Pull the plug out of the socket.

! If this procedure is not followed, the alarm may sound. This alarm does not indicate a malfunction. To restore normal operation, hold the ON/OFF button down for more than two seconds. To disconnect the appliance, follow points 1 and 2 above.

### Cleaning the appliance

- The external and internal parts, as well as the rubber seals may be cleaned using a sponge that has been soaked in lukewarm water and bicarbonate of soda or neutral soap. Do not use solvents, abrasive products, bleach or ammonia.
- The removable accessories may be soaked in warm water and soap or dishwashing liquid. Rinse and dry them carefully.
- The back of the appliance may collect dust which can be removed by delicately using the hose of a vacuum cleaner set on medium power. The appliance must be switched off and the plug must be pulled out before cleaning the appliance.

### Avoiding mould and unpleasant odours

- The appliance is manufactured with hygienic materials which are odour free. In order to maintain an odour free refrigerator and to prevent the formation of stains, food must always be covered or sealed properly.
- If you want to switch the appliance off for an extended period of time, clean the inside and leave the doors open.

### Defrosting the appliance

! Follow the instructions below.

Do not speed up the defrosting process by using any devices or tools other than the scraper provided, you may damage the refrigeration circuit.

### Defrosting the refrigerator compartment

The refrigerator has an automatic defrosting function: water is ducted to the back of the appliance by a special discharge outlet (see diagram) where the heat produced by the compressor causes it to evaporate. It is necessary to clean the discharge hole regularly so that the water can flow out easily.

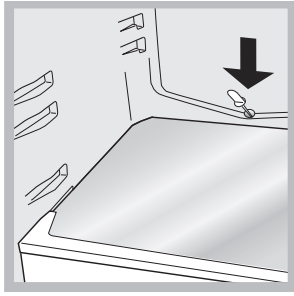

### Defrosting the freezer compartment

If the frost layer is greater than 5 mm, it is necessary to defrost manually:

1. The day before defrosting, press the SUPER FREEZE button to further cool the food. The function is automatically disabled after 24 hours, or it may be disabled at any moment by pressing the SUPER FREEZE button again. Press the ON/OFF button to switch off the appliance.
2. Wrap frozen foods in newspaper and place them in another freezer or in a cool place.
3. Leave the door open until the frost has melted completely. This can be made easier by placing containers with lukewarm water in the freezer compartment.
4. Clean and dry the freezer compartment carefully before switching the appliance on again.

### Replacing the light bulb \*

To replace the light bulb in the refrigerator compartment, pull out the plug from the electrical socket. Follow the instructions below. Access the light bulb by removing the cover as indicated in the diagram. Replace it with a similar light bulb within the power range indicated on the cover.

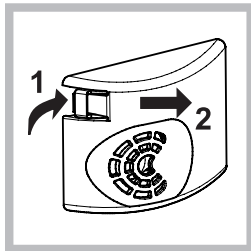

## Precautions and tips

! The appliance was designed and manufactured in compliance with international safety standards. The following warnings are provided for safety reasons and must be read carefully.



This appliance complies with the following Community Directives:  
 - 73/23/EEC of 19/02/73 (Low Voltage) and subsequent amendments;  
 - 89/336/EEC of 03.05.89 (Electromagnetic Compatibility) and subsequent amendments;  
 - 2002/96/CE.

### General safety

- The appliance was designed for domestic use inside the home and is not intended for commercial or industrial use.
- The appliance must be used to store and freeze food products by adults only and according to the instructions in this manual.
- The appliance must not be installed outdoors, even in covered

areas. It is extremely dangerous to leave the appliance exposed to rain and storms.

- Do not touch the appliance with bare feet or with wet or moist hands and feet.
- Do not touch the internal cooling elements: this could cause skin abrasions or frost/freezer burns.
- When unplugging the appliance always pull the plug from the mains socket, do not pull on the cable.
- Before cleaning and maintenance, always switch off the appliance and disconnect it from the electrical supply. It is not sufficient to set the temperature adjustment knobs on ON/OFF (appliance off) to eliminate all electrical contact.
- In the case of a malfunction, under no circumstances should you attempt to repair the appliance yourself. Repairs carried out by inexperienced persons may cause injury or further malfunctioning of the appliance.
- Do not use any sharp or pointed utensils or electrical equipment - other than the type recommended by the manufacturer - inside the frozen food storage compartments.
- Do not put ice cubes taken directly from the freezer into your mouth.
- This appliance is not intended for use by persons (including children) with reduced physical, sensory or lack of experience and knowledge unless they have been given supervision or instruction concerning use of the appliance by a person responsible for their safety. Children should be supervised to ensure that they do not play with the appliance.
- Keep packaging material out of the reach of children! It can become a choking or suffocation hazard.

### Disposal

- Observe local environmental standards when disposing packaging material for recycling purposes.
- The European Directive 2002/96/EC on Waste Electrical and Electronic Equipment (WEEE), requires that old household electrical appliances must not be disposed of in the normal unsorted municipal waste stream. Old appliances must be collected separately in order to optimise the recovery and recycling of the materials they contain and reduce the impact on human health and the environment. The crossed out "wheeled bin" symbol on the product reminds you of your obligation, that when you dispose of the appliance it must be separately collected. Consumers should contact their local authority or retailer for information concerning the correct disposal of their old appliance.

### Respecting and conserving the environment

- Install the appliance in a fresh and well-ventilated room. Ensure that it is protected from direct sunlight and do not place it near heat sources.
- Try to avoid keeping the door open for long periods or opening the door too frequently in order to conserve energy.
- Do not fill the appliance with too much food: cold air must circulate freely for food to be preserved properly. If circulation is impeded, the compressor will work continuously.
- Do not place hot food directly into the refrigerator. The internal temperature will increase and force the compressor to work harder and will consume more energy.
- Defrost the appliance if ice forms (see **Maintenance**). A thick layer of ice makes cold transference to food products more difficult and results in increased energy consumption.

## Troubleshooting

If the appliance does not work, before calling for Assistance (see Assistance), check for a solution from the following list.



**The display is completely switched off.**

- The plug has not been inserted into the electrical socket, or not far enough to make contact, or there is no power in the house.

**The motor does not start.**

- The appliance comes with a motor protection control (see Start-up and use).

**The display is on but it is dim.**

- Pull out and reverse the plug before putting it back in the socket

**The alarm sounds and DOOR OPEN ALARM flashes on the display (“d” is displayed instead of the REFRIGERATOR temperature).**

- The refrigerator door has been open for more than two minutes. The sound alert stops when the door is closed or when the appliance is switched off and on again.

**The alarm sounds and TEMPERATURE ALARM flashes on the display (“A1” is displayed instead of the FREEZER temperature).**

- The temperature inside the freezer is too high. The freezer will maintain a temperature of around 0°C so that the food will not refreeze, allowing you to eat it within 24 hours or to refreeze it after it has been cooked. To switch off the buzzer, open and close the appliance door or press the + and – freezer temperature adjustment buttons once. Press these buttons a second time to display the set value on the freezer display, switch off the TEMPERATURE ALARM LED and restore normal operation.

**The alarm sounds and temperature alarm flashes on the display (“A2” is displayed instead of the FREEZER temperature).**

- The temperature of the freezer is dangerously high: the food inside must not be eaten. The freezer will maintain a temperature of approximately -18°C. To switch off the buzzer, open and close the appliance door or press the + and – freezer temperature adjustment buttons once. Press these buttons a second time to display the set value on the freezer display, switch off the TEMPERATURE ALARM LED and restore normal operation.

**The refrigerator and the freezer do not cool well.**

- The doors do not close properly or the seals are damaged.
- The doors are opened too frequently.
- The temperature that has been set is too high (see Start-up and use).
- The refrigerator or the freezer have been over-filled.
- The atmospheric temperature of the area surrounding the appliance is lower than 14°C.

**The food inside the refrigerator is beginning to freeze.**

- The temperature that has been set is too low (see Start-up and use).

**The motor runs continuously.**

- The SUPER FREEZE button has been pressed (rapid freezing): the yellow SUPER FREEZE light is on or flashing (see Description).
- The door is not closed properly or is continuously opened.
- The outside ambient temperature is very high.

**The appliance makes a lot of noise.**

- The appliance has been installed between cabinets that vibrate and make noise.
- The internal refrigerant makes a slight noise even when the compressor is off. This is not a defect, it is normal.

**There is water at the bottom of the refrigerator.**

- The water discharge hole is blocked (see Maintenance).





