

Assembly Instructions

Important

Before you begin, please make sure all parts and proper quantities are included. Any parts damaged during shipment must be reported within 15 days of receipt. To report information regarding damage, to purchase parts or accessories, or if you have any questions, please contact us at:

www.spectrumfurniture.com
715-723-6750, 800-235-1262

Thank you for purchasing Spectrum products!

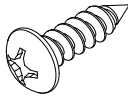

(20) 0101382
#14 x 7/8" PHSM screws

1. Attach leg mechanisms

1. Place worksurface face-down onto a non-abrasive surface.
2. Orient the leg mechanisms and release handle as shown and align with the worksurface mounting holes. **Figure 1A.**
3. Attach the leg mechanisms and release handle to the worksurface using (20) #14 x 7/8" PHSM screws and tighten securely.
4. Secure the cables to the worksurface with the included clips, (4) #8 x 3/4" PHSM screws, and pre-drilled holes. **Figure 1B.**

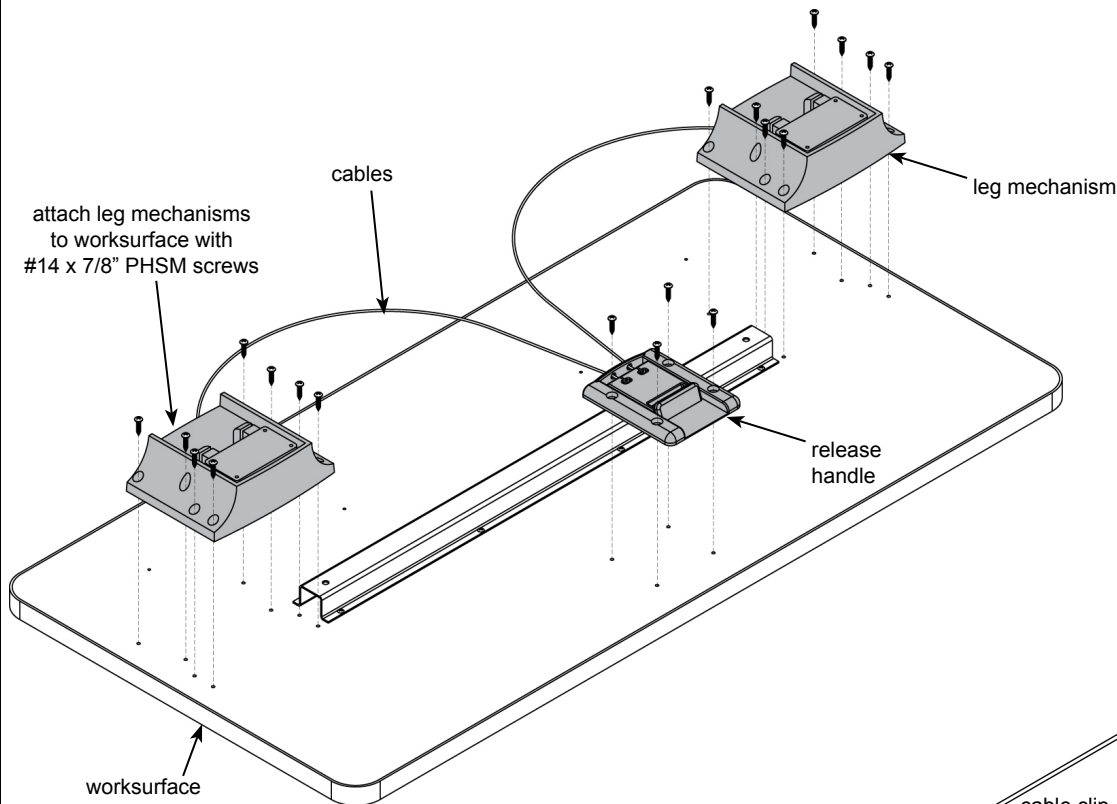
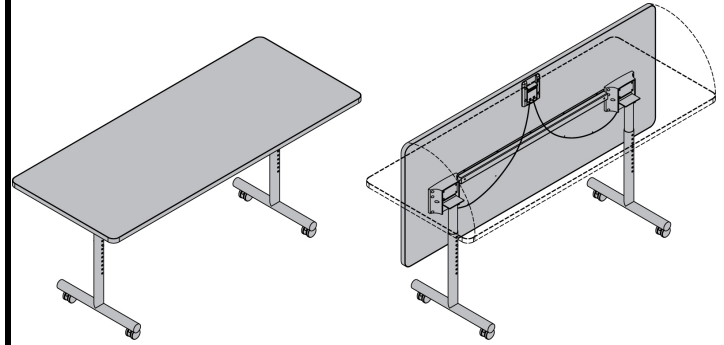
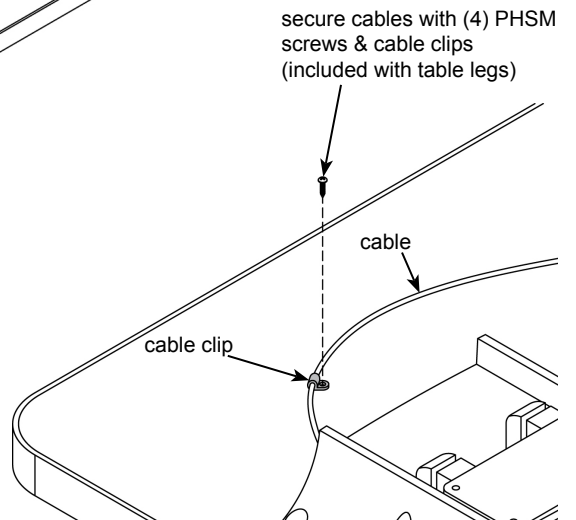

Figure 1A

Figure 1B



Flex Flip Tables

24"D

37310 - 48"W
37312 - 60"W
37314 - 72"W

30"D

37311 - 48"W
37313 - 60"W
37315 - 72"W

Tools Required



Phillips
Screwdriver



Hex wrench
(included
with legs)



1/2" wrench

2. Attach legs

1. Set a leg on each leg mechanism. **Figure 2.**
2. Attach each leg with the included hex screws (4 per leg) and hex wrench.
3. Tighten screws securely.
4. Be sure swivel wheels are tightened securely. (Tighten with 1/2" wrench if necessary.)
5. Carefully tip the table upright- this will require two people.

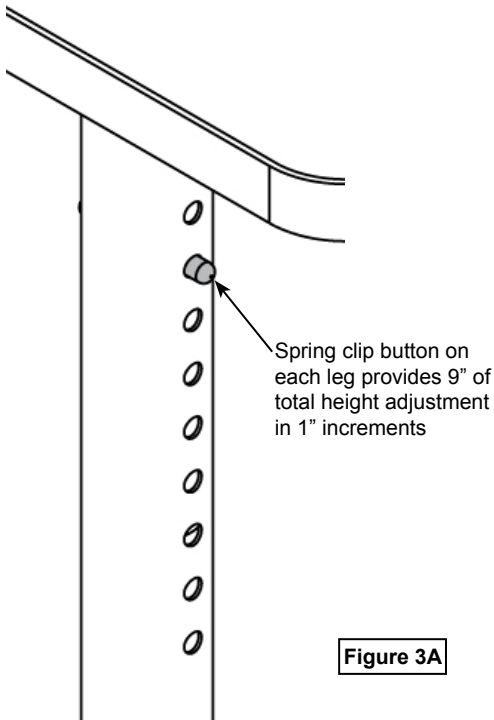

Figure 3A

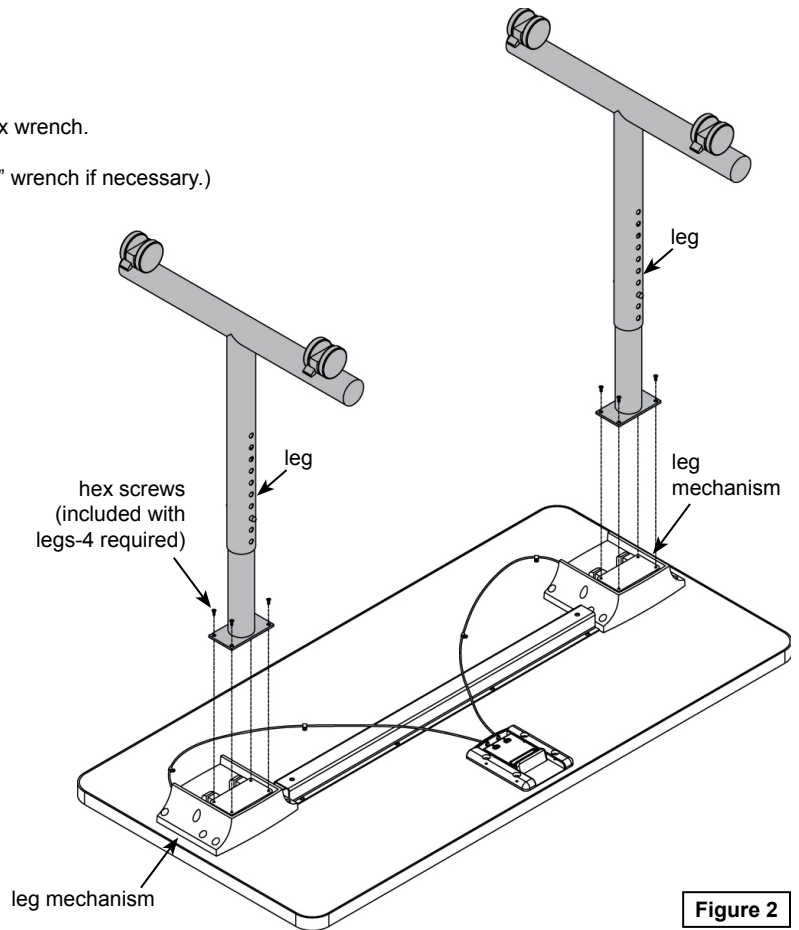

Figure 2

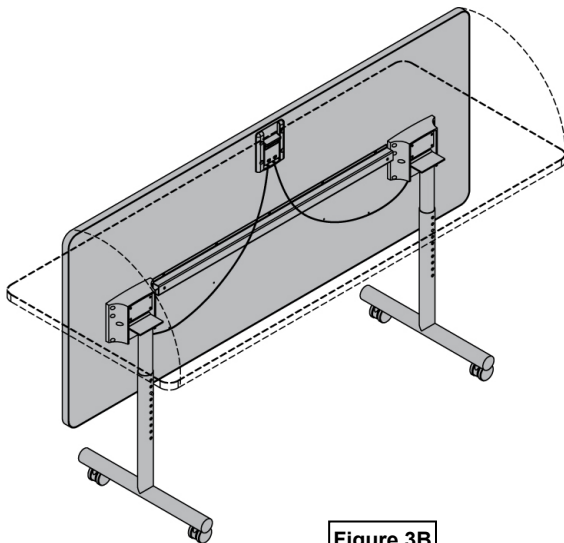

Figure 3B

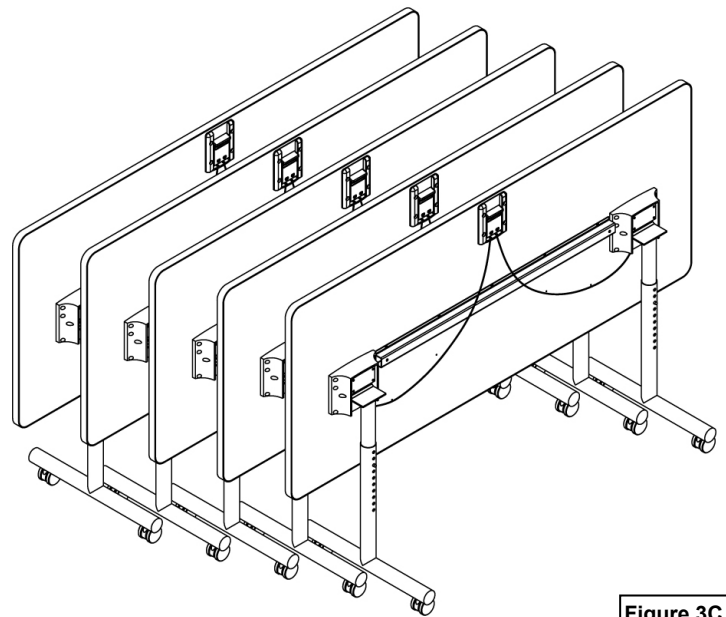

Figure 3C

3. Table operation

- To adjust the worksurface height, press the spring clip button on one leg and raise or lower the worksurface and upper leg assembly (slightly twisting then sliding the leg after the button has been pressed will help keep it retracted until its aligned with the new hole.) **Figure 3A.** Align the spring clip button with one of the adjustment holes to lock the leg into the new position. Repeat this procedure on the other leg while making sure to use the same hole position on both legs.
- To flip-up the worksurface, pull the release lever while lifting up the edge of the worksurface until it locks into place. **Figure 3B.** To lower, pull the release lever while lowering the worksurface-be sure it locks into place. Multiple tables can be "nested" together next to a wall to save space. **Figure 3C.**

Warranty

WE WILL MAKE IT RIGHT FOR YOU!

Spectrum is committed to provide complete customer satisfaction. Each of our products is manufactured from the best materials available and each product is stringently monitored throughout the production process through our P.A.C.E. program (Product Assurance to meet Customer Expectations).

We expressly warrant that Spectrum products will be of good quality and workmanship and free from defect for the period set out in the warranty table below from the date of delivery. This warranty shall not apply to defects or damage resulting from misuse, abuse, neglect, improper care, modification or repair not authorized by Spectrum, or any other cause outside the control of Spectrum. Spectrum will, at its sole option, either repair or replace the defective product.

This warranty is exclusive; no other warranty, written or oral, is expressed or implied. This warranty is given by Spectrum to Buyer and to no other person or legal entity. No Spectrum dealer, distributor, agent or employee is authorized to make any modification or addition to this warranty.

NOTWITHSTANDING ANYTHING TO THE CONTRARY, SPECTRUM WILL NOT UNDER ANY CIRCUMSTANCES BE LIABLE FOR INDIRECT OR LIQUIDATED DAMAGES, INCLUDING CONSEQUENTIAL, INCIDENTAL AND SPECIAL DAMAGES. IN NO EVENT SHALL SPECTRUM'S LIABILITY, WHETHER UNDER CONTRACT OR WARRANTY, IN TORT OR OTHERWISE, EXCEED THE PURCHASE PRICE RECEIVED BY SPECTRUM FOR THE PRODUCT AT ISSUE AND "RECALL ACTION" EXPENSES. SPECTRUM SHALL NOT BE SUBJECT TO ANY OTHER OBLIGATIONS OR LIABILITIES, WHETHER ARISING OUT OF BREACH OF CONTRACT, WARRANTY, TORT (INCLUDING NEGLIGENCE AND STRICT LIABILITY) OR OTHER THEORIES OF LAW, WITH RESPECT TO PRODUCTS SOLD OR SERVICES RENDERED BY SPECTRUM, OR ANY UNDERTAKINGS, ACTS OR OMISSIONS RELATING THERETO.

Our Customer Service Department is ready to provide immediate attention to any questions, comments or concerns. They are available to answer your calls Monday through Friday from 7 am to 5 pm CST. In addition your product comments or concerns are welcome via e-mail at: spectrum@spectrumfurniture.com.

Warranty Table

Item	Warranty Period
<ul style="list-style-type: none"> Adjustable Crank/Electric Desk Legs Flat Panel Desk Gas Cylinders 	<ul style="list-style-type: none"> 1 Year
<ul style="list-style-type: none"> Adjustable Height Chair Parts – including frames, gas cylinders, wood and plastic parts, and control handles Adjustable Height Chair Parts Casters Adjustable Height Chair Upholstery In-Stock Upholstery Graded-In Fabrics and Customer Owned Material 	<ul style="list-style-type: none"> 7 Years 2 Years 2 Years No Warranty
<ul style="list-style-type: none"> Height Adjustable Columns and Lifts General Use Casters Electrical Keyboard/Mouse Trays 	<ul style="list-style-type: none"> 1 Year
<ul style="list-style-type: none"> Flat Panel Monitor Arm – General Parts Flat Panel Monitor Arm – Gas Cylinders 	<ul style="list-style-type: none"> 5 Years 2 Years
<ul style="list-style-type: none"> Computer Desk Chassis Cart Chassis Lectern Chassis 	<ul style="list-style-type: none"> 10 Years

