

RIG

User Guide

Contents

Welcome	3
What's in the box	4
System overview	5
Be safe	6
Headset basics	7
Installing a microphone	7
Using the inline microphone	8
PC setup	9
Xbox 360 setup	10
Xbox 360 optical cable setup	10
Xbox 360 component setup	11
Xbox 360 HDMI setup*	12
Sony Playstation setup	13
PS3 optical cable setup	13
PS3 component setup	14
PS4 setup	15
PS Vita setup	16
The mixer	17
Powering up	17
Connecting a mobile device	17
Master volume control	17
Mic rocker switch	18
Game/chat sound balancer	18
Game/mobile sound balancer	19
Mixing and controlling music from a mobile device	19
Take calls. Keep playing.	20
Master mute	20
Equalizer	20
Combo chat	21
FAQ	22
Support	23

Welcome

Congratulations on the purchase of your new RIG Headset + Mixer! Plantronics Gaming would like to welcome you into the RIG family of high-end audio products.

RIG was designed from the ground up for deeply immersive game audio but without losing your connection to the world. When connected to a mobile device, RIG blends game and chat with mobile audio, apps, and alerts—and best of all—enables you to take calls without pausing the game.

This guide will help you get set up and start exploring all RIG has to offer.

GLHF!

What's in the box

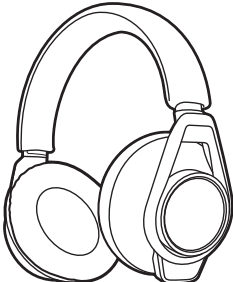

Headset

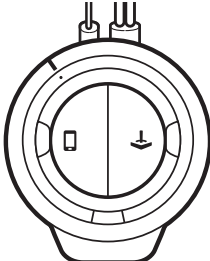

Mixer

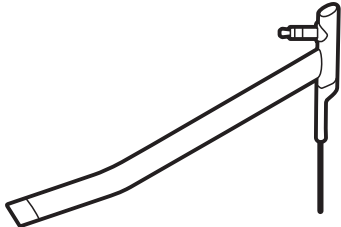

Boom microphone/cable

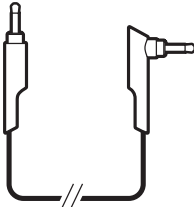

Xbox LIVE® chat cable

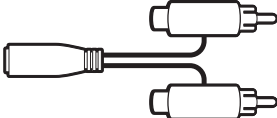

RCA piggyback cable

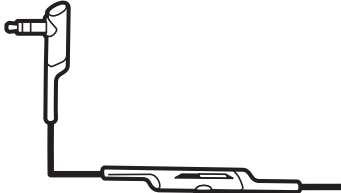

Optional in-line microphone/
cable

System overview

Headset

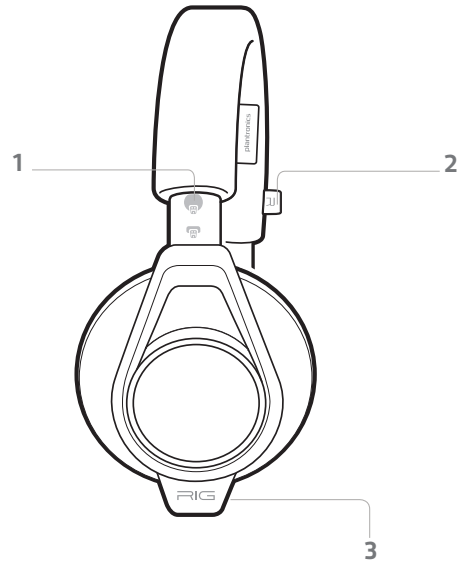

- 1 Headband adjustment
- 2 Right ear indicator

- 3 Microphone port

Mixer

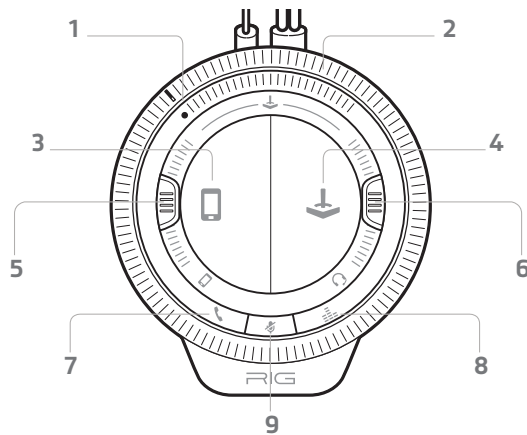

- 1 Power on/off
- 2 Master volume dial
- 3 Mobile microphone
- 4 Game microphone
- 5 Game/mobile sound balancer

- 6 Game/chat sound balancer
- 7 Call button
- 8 Equalizer button
- 9 Master mute button

Boom microphone/cable

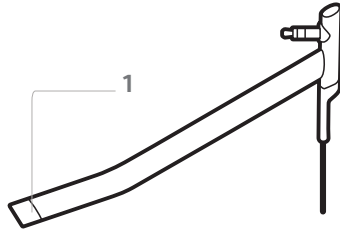

1 Boom

Optional inline microphone/cable

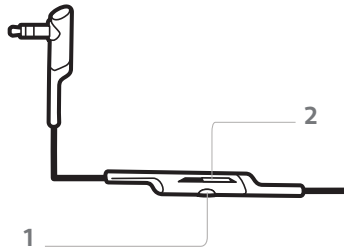

1 Call button

2 Mute switch

Be safe

Please read the safety guide for important safety, charging, battery and regulatory information before using your new headset.

Headset basics

Designed to connect and mix audio from your mobile device with a game console or PC, the mixer shines when integrated with a mobile device. This next section enables you to get the most out of everything RIG can do for your game.

Installing a microphone

Installing a microphone and switching cables is fast and easy. Two microphones are included: a boom microphone/cable for the best gaming audio experience and a low profile in-line microphone/cable to use with mobile devices.

- 1 Insert the connector of the desired microphone cable into the port located on the bottom left ear cup of the headset.

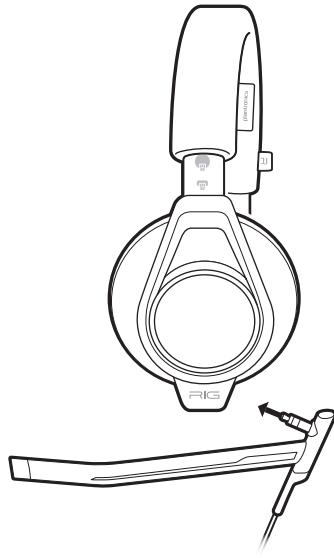

PRO TIP For proper performance, make sure that the microphone is fully seated in the left ear cup. Press the microphone boom firmly into the port until you feel it lock into place.

- 2 If you are using the boom/microphone cable, adjust it so the boom microphone is near your mouth for the best fidelity.

PRO TIP The Master mute button will also glow red when the headset jack is disconnected or improperly connected to the mixer. Be certain that the headset jack is fully inserted into the mixer. As the headset connects properly to the mixer, the red light on the master mute button will automatically shut off.

Using the inline microphone

Use the stealth inline microphone for the occasions when connecting directly to a mobile device. The controls are easy to use and perfect for mobile calls, gaming and music on-the-go. Use the boom microphone for gaming sessions.

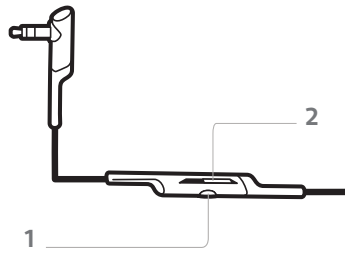

1. Call button

2. Mute button

- 1 **Make a call** To make a call, dial the number on your mobile device.
- 2 **Answer a call** To answer a call, press the call control button.
- 3 **End a call** To end a call, press the call button again.
- 4 **Adjust volume** To adjust volume, adjust it on your mobile device.
- 5 **Mute** To mute the call, switch the mute button up towards the headset. To unmute, move it back down.

PRO TIP *If the inline cable is plugged into the mixer, the Call button on the inline microphone will be disabled and will not perform any call control functions.*

PC setup

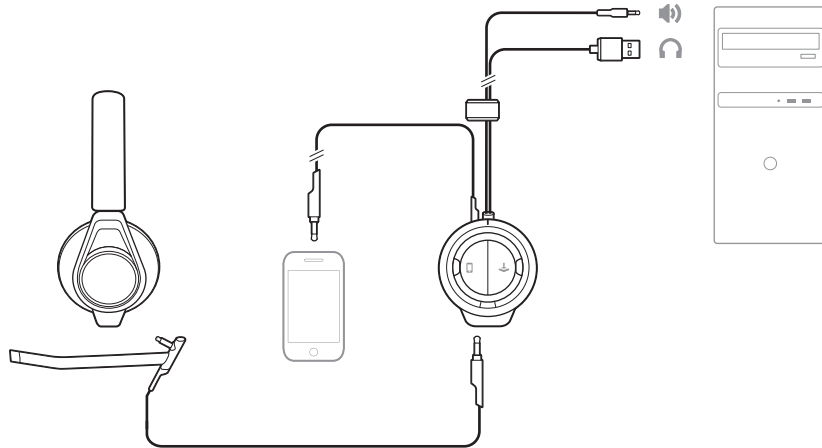

- 1 Make sure the boom microphone is attached properly to the headset. Insert the headset 3.5mm plug into the headset jack on the front of the mixer located under the RIG logo tab, on the left side.
- 2 Attached to the mixer is a set of cables that includes a long cord with a 3.5mm audio and USB connectors. Plug the USB into an available port on your PC and the 3.5mm into the headset/headphone speaker jack.
For proper function, make sure that the USB connector is plugged into the PC itself and not an external USB power source
- 3 For best performance, assign "Plantronics RIG" as the PC microphone via USB. Game audio is received via the 3.5mm input. Having these two connections provides discrete audio streams to the mixer, enabling balance of voice-to-game sound on-the-fly with the game/chat sound balancer without having to adjust software settings during a game.
PRO TIP *Dedicated VoIP software, such as Skype, Ventrilo, and Team Speak all enable discrete assignment of microphone transmit/receive to the mixer USB device. However, some games that provide in-game VoIP may not enable discreet assignment of voice/game audio. Adjustment will need to be done using the in-game software.*
- 4 Find a good balance of game and voice audio by adjusting the Game/chat sound balancer on the right side of the mixer (over the orange LEDs). Remember that the 3 o'clock position will enable equal volume of both game and voice audio signal. Sliding the control upward makes game sound louder and voice (game chat) quieter. Sliding the control downward increases voice (game chat) while making game audio quieter.

Xbox 360 setup

How you connect your Xbox 360's audio/video to your TV will generally be the most important factor in how audio is connected to the mixer.

Xbox 360 optical cable setup

Use this setup if your TV or primary audio device has an optical port, and you have an optical cable (not included in package, sold separately by other manufacturers). An optical cable is an optional connection method that offers the highest performance audio possible with the mixer.

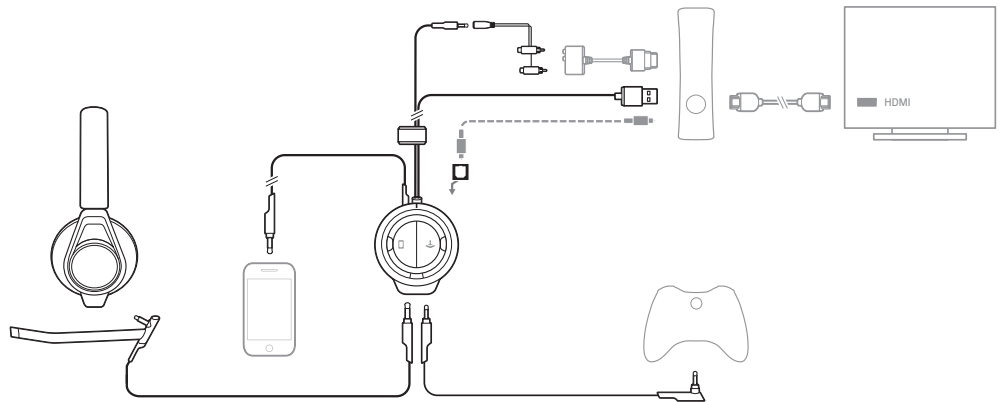

- 1 Attach a Toslink digital optical cable to the appropriate port on your Xbox 360 (Xbox 360 Slim models or to the Microsoft AV Adapter with included optical audio port), HDTV, A/V Receiver, or other audio device.
- 2 Plug the opposite end of the optical cable into the optical port on the rear of the mixer. On your Xbox, go to Settings > System > Console Settings > Audio. Then select Digital Output > Digital Stereo.
- 3 Make sure the boom microphone is attached properly to the headset. Insert the 3.5mm plug into the headset jack on the front of the mixer located under the RIG logo tab, on the left side.
- 4 Insert the included Xbox Live chat cable into the 2.5mm jack (smaller of the two) located to the right of the headset jack on front of the mixer. Insert the other end into your Xbox game controller. For best performance, use the connector with the 90 degree angled plug attached to the Xbox 360 controller and the straight plug connected to the mixer.
- 5 Find a good balance of game and voice audio by adjusting the Game/chat sound balancer on the right side of the mixer (over the orange LEDs). Remember that the 3 o'clock position will enable equal volume of both game and voice audio signal. Sliding the control **upward** makes game sound louder and voice (game chat) quieter. Sliding the control **downward** increases voice (game chat) while making game audio quieter.

Xbox 360 component setup

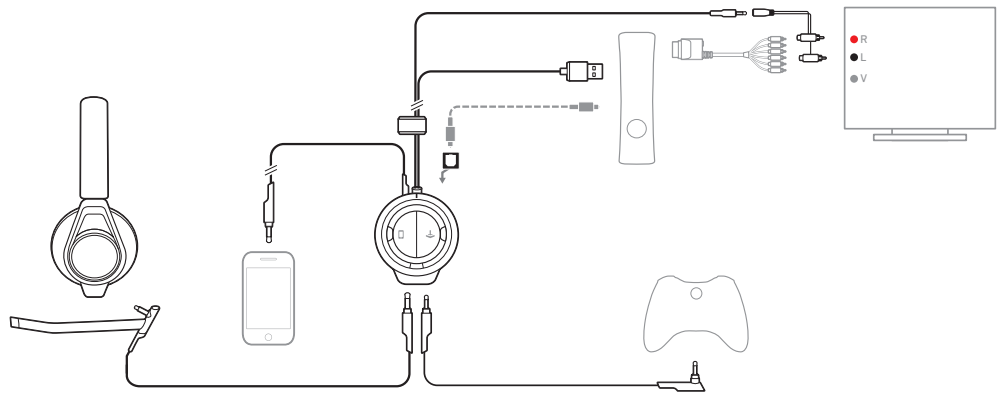

- 1 Make sure the boom microphone is attached properly to the headset. Insert the 3.5mm plug into the headset jack on the front of the mixer located under the RIG logo tab, on the left side.
- 2 Connect the USB cable from the mixer into a USB port on the Xbox 360. For proper function: make sure that the USB connector is plugged into the Xbox 360 itself and not an external USB power source.
- 3 Attach the included 3.5mm-to-RCA Piggy back adapter to the end of the long 3.5 mm plug cable.
- 4 Attach the RCA Piggyback **in-between** the Xbox AV cable (included with most Xbox 360 models) and the primary audio source (TV, receiver, etc).
- 5 Insert the included Xbox Live chat cable into the 2.5mm jack (smaller of the two) located to the right of the headset jack on front of the mixer. Insert the other end to the Xbox game controller. For best performance, use the connector with the 90 degree angled plug attached to the Xbox 360 controller and the straight plug connected to the mixer.
- 6 Find a good balance of game and voice audio by adjusting the Game/chat sound balancer on the right side of the mixer (over the orange LEDs). Remember that the 3 o'clock position will enable equal volume of both game and voice audio signal. Sliding the control **upward** makes game sound louder and voice (game chat) quieter. Sliding the control **downward** increases voice (game chat) while making game audio quieter.

Xbox 360 HDMI setup*

*Some components sold separately.

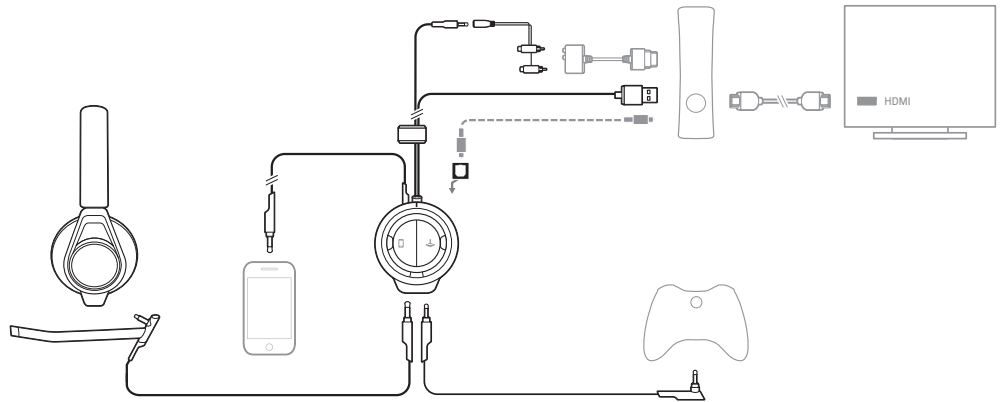

- 1 Make sure the boom microphone is attached properly to the headset. Insert the 3.5mm plug into the headset jack on the front of the mixer located under the RIG logo tab, on the left side.
- 2 Connect the USB cable from the mixer into a USB port on the Xbox 360 (For proper function: make sure that the USB connector is plugged into the Xbox 360 itself and not an external USB power source. .
- 3 Attach the included 3.5mm-to-RCA Piggy back adapter to the end of the long 3.5 mm plug cable.
 - **Option 1:** Attach the RCA Piggyback to the AV HDMI adapter. This adapter is not included and is sold separately by Microsoft and other manufacturers. Plantronics does not supply this component. Attach the AV HDMI adapter into the Xbox 360.
 - **Option 2:** Alternatively, if your TV or AV Receiver has an available RCA audio out or a 3.5mm headphone feature, connect the audio cable directly to your TV. You may need to change the audio settings of your TV to pass audio through to an external device and turn off the TV speaker. Note that the USB cable must still be connected to the Xbox 360 for power.
- 4 Insert the included Xbox Live chat cable into the 2.5mm jack (smaller of the two) located to the right of the headset jack on front of the mixer. Insert the other end to your Xbox game controller. For best performance, use the connector with the 90 degree angled plug attached to the Xbox 360 controller and the straight plug connected to the mixer.
- 5 Find a good balance of game and voice audio by adjusting the Game/chat sound balancer on the right side of the mixer (over the orange LEDs). Remember that the 3 o'clock position will enable equal volume of both game and voice audio signal. Sliding the control **upward** makes game sound louder and voice (game chat) quieter. Sliding the control **downward** increases voice (game chat) while making game audio quieter.

Sony Playstation setup

How you connect your Sony PS3 and PS4's audio/video to your TV will generally be the most important factor in how audio is connected to the mixer.

PS3 optical cable setup

Use this setup if your TV or primary audio device has an optical port and if you have an optical cable (not included in package, sold separately by other manufacturers). An optical cable is an optional connection method that offers the highest performance audio possible with the mixer.

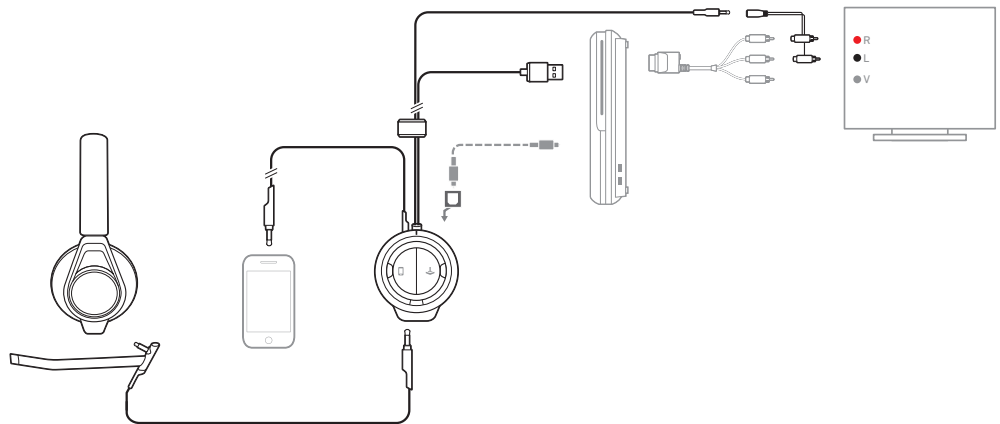

- 1 Make sure the boom microphone is attached properly to the RIG headset. Insert the 3.5mm plug into the headset jack on the front of the mixer located under the RIG logo tab, on the left side.
- 2 Attach a Toslink digital optical cable to the appropriate port on your Playstation 3, HDTV, A/V Receiver, or other audio device.
- 3 Plug the opposite end of the optical cable into the optical port on the rear of the mixer.
- 4 Set the audio settings to enable chat with the microphone on the PS3. Go to: Settings > Accessory Settings > Audio Device Settings > Input Device (select "Plantronics RIG") > OK
- 5 Set the audio settings on the PS3 to output both TV (HDMI) and the mixer. Go to: Settings > Sound Settings > Audio Output Settings > Audio Multioutput > On
- 6 Find a good balance of game and voice audio by adjusting the Game/chat sound balancer on the right side of the mixer (over the orange LEDs). Remember that the 3 o'clock position will enable equal volume of both game and voice audio signal. Sliding the control **upward** makes game sound louder and voice (game chat) quieter. Sliding the control **downward** increases voice (game chat) while making game audio quieter.

PS3 component setup

- 1 Make sure the boom microphone is attached properly to the headset. Insert the 3.5mm plug into the headset jack on the front of the mixer located under the RIG logo tab, on the left side.

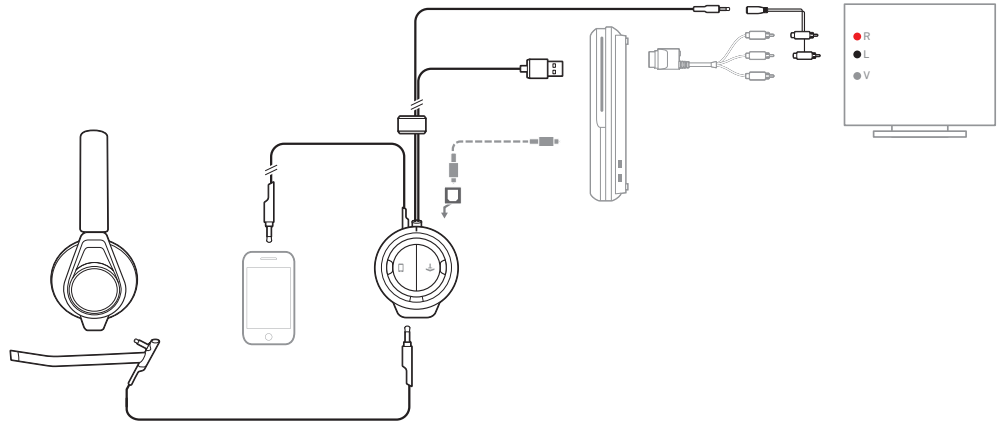

- 2 Connect the USB cable from the mixer into an available USB port on the PS3.
- 3 Attach the included 3.5 adapter/RCA piggyback to the end of the long 3.5 mm plug cable.
- 4 Attach the RCA piggyback in between the PS3 AV cable (included with all PS3 models) and the primary audio source (TV, receiver, etc).
NOTE Alternatively, if your TV has RCA audio out or a 3.5mm headphone feature, connect the audio cable to your TV. You may need to change the audio settings of your TV to pass audio through to an external device and turn off the TV speaker.
- 5 Connect the USB cable from the mixer into a USB port on the PS3. For proper function, make sure that the USB connector is plugged into the PS3 itself and not an external USB power source.
- 6 Set the audio settings on the PS3. Go to: Settings > Accessory Settings > Audio Device Settings > Input Device (select "Plantronics RIG") > OK
- 7 Find a good balance of game and voice audio by adjusting the Game/chat sound balancer on the right side of the mixer (over the orange LEDs). Remember that the 3 o'clock position will enable equal volume of both game and voice audio signal. Sliding the control **upward** makes game sound louder and voice (game chat) quieter. Sliding the control **downward** increases voice (game chat) while making game audio quieter.

PS4 setup

Install the latest PS4 operating system

Installing System Update V1.50 is required to use the voice communication features. You must also sign into your account on the PlayStation Network.

PRO TIP Ensure you have the latest PS4 operating system

- 1 On the PlayStation Dynamic Menu, select Settings > System Software Update.
- 2 If necessary, follow the on-screen instructions to download and install the latest operating system on your PS4.

Connect the headset and mixer

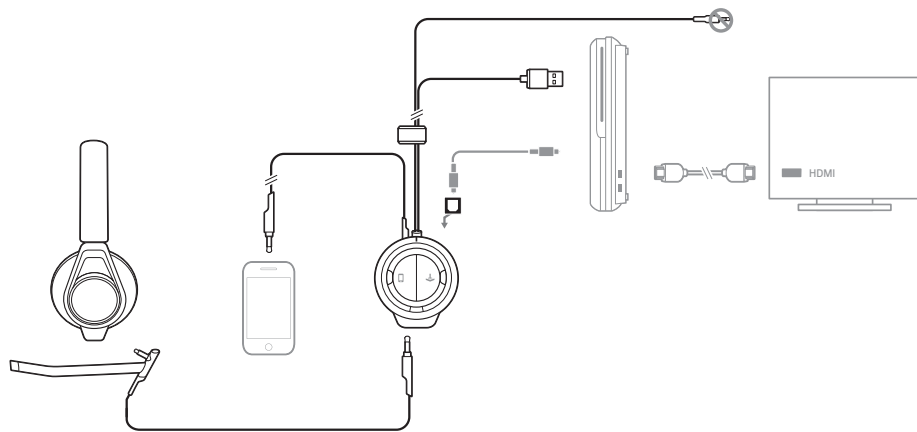

- 1 Make sure the boom microphone is attached properly to the headset. Insert the 3.5mm plug into the headset jack on the front of the mixer located under the RIG logo tab, on the left side.
- 2 Connect an TOSlink optical cable (sold separately) from the optical input on the rear of the mixer to the optical output on the back of the PS4.
- 3 Connect the USB cable from the mixer into an available USB port on the PS4.

Configure PS4 settings

- 1 On the PlayStation Dynamic Menu, select Settings > Sound and Screen > Audio Output Settings > Primary Output Port > Digital Out (Optical).
- 2 Again select Audio Output Settings > Output to Headphones > Chat Audio (default) (ensure Chat Audio is selected and not All Audio).
- 3 For the third time, select Audio Output Settings > Audio Format (Priority) > Linear PCM (default).

PRO TIP If RIG isn't detected by the PS4 then Output to Headphones will be grayed out under the Audio Output Settings. To correct this, unplug the USB cable and plug the cable into the PS4 again. The PS4 will prompt you to assign the "Headset" to a user. At this point, assign it to your user account and the Output to Headphones option should be available to you.

PRO TIP If your voice chat suddenly stops working mid-game, press and hold the PlayStation button for around three seconds to pull up the quick settings. Select Adjust Device and ensure that Volume Control (Headphones) isn't grayed out and that Output to Headphones is set to Chat Audio and not All Audio.

- 4 Find a good balance of game and voice audio by adjusting the game/chat sound balancer on the right side of the mixer (over the orange LEDs). Remember that the 3 o'clock position will enable equal volume of both game and voice audio signal. Sliding the control **upward** makes game sound louder and voice (game chat) quieter. Sliding the control **downward** increases voice (game chat) while making game audio quieter.

- PS Vita setup
- 1 Insert the 3-pole connector of the inline microphone cable into the port located on the bottom of the left ear cup of the headset.
 - 2 Insert the 4-pole connector into the 3.5mm jack on the PS Vita.

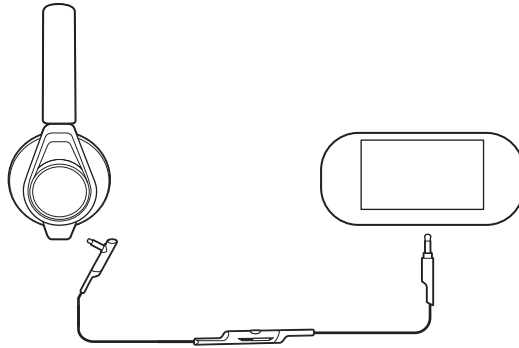

The mixer

Powering up

PRO TIP The mixer must be connected via USB to the platform that you are using it with for proper operation. External USB power adapters will NOT function correctly. Do not shake or taunt the mixer.

Rotate the outer Master volume dial to the right (clockwise) to turn on the mixer. By default, both orange and blue lights will illuminate indicating proper enumeration, then settling on the Game mode (orange) or Mobile mode (blue) that the Mic rocker switch is deployed to. Rotate the Master volume dial left (counter-clockwise) until the white line meets the white dot on the mixer to turn off the mixer. A slight detent indicates the off position and the mixer lights and audio will power down.

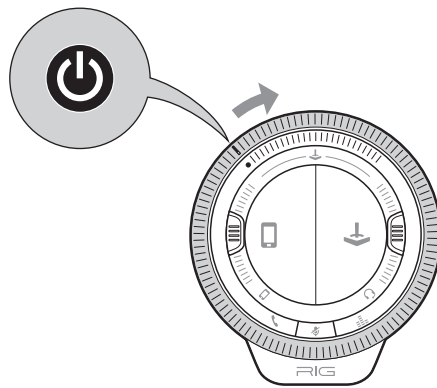

Connecting a mobile device

Remove the short mobile cable connector from the rubber caddy along the main cable and connect it firmly into your mobile device.

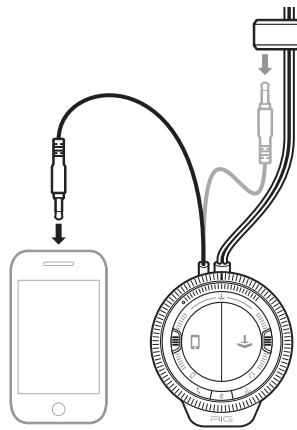

PRO TIP Make sure the mobile device is powered on and volume is set to an appropriate level (a good rule of thumb is to set devices to at least 50% volume).

Master volume control

The Master volume dial controls the sum volume level of all audio devices connected to the mixer.

Turn the Master volume dial to the right to increase volume and to the left to decrease volume.

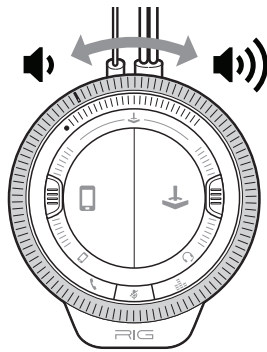

CAUTION Do not use headsets at high volumes for an extended period of time. Doing so can cause hearing loss. Always listen at moderate levels. See for more information on headsets and hearing.

Mic rocker switch

In the center of the mixer, the large, glossy paddle controls many elements of the audio experience. Not only does the Mic rocker switch control which device your microphone transmits (Tx) to—like the connected console or mobile device—it also shapes what you hear.

For example, when the Mic rocker switch is deployed to the Game Mode (glows orange), the Game/chat sound balancer on the right side becomes active, and controls the balance between game sound and game chat. Additionally, the microphone is only active to the game chat (ex. Xbox LIVE, Skype, etc.), and muted to connected mobile devices. However, mobile audio (Rx) can be heard, and the level controlled by the Game/mobile sound balancer.

When the Mic rocker switch is deployed to Mobile mode (glows blue), the Game/mobile sound balancer on the left side is active, and controls the balance between mobile sound and game sound. The microphone is now only active to connected mobile devices, and transmission is MUTED to game chat (Xbox LIVE, Skype, etc.). In the default configuration, the mixer also mutes incoming (Rx) game chat.

In summary, the Mic rocker switch performs a **macro function**, or in other words, does several things at once.

For example, switching the Mic rocker switch from Game mode (orange) to Mobile mode (blue) causes the following to occur:

- Microphone transmission (Tx) to mobile connected device is **unmuted**
- Microphone transmission (Tx) to Game chat (Xbox LIVE, Skype, etc) is **muted**
- Incoming Game chat (Rx) is **muted** (default mode)
- [GAME/CHAT SOUND] balancer now actively controls the Game Sound volume. This enables a lower setting of game sound, if desired, when taking a phone call.

PRO TIP Switching the Mic rocker switch from Mobile mode (blue) to Game mode (orange) reverses all four of the above to their previous states.

Game/chat sound balancer

When the Mic rocker switch is deployed to the Game mode (orange), the Game/chat sound balancer is active and controls the balance of game audio to game chat.

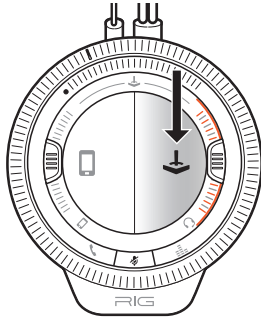

Find a good balance of game and voice audio by adjusting the Game/chat sound balancer on the right side of the mixer (over the orange LEDs). Remember that the 3 o'clock position will enable equal volume of both game and voice audio signal. Sliding the control **upward** makes game sound louder and voice (game chat) quieter. Sliding the control **downward** increases voice (game chat) while making game audio quieter.

Game/mobile sound balancer

When the Mic rocker switch is deployed to the Mobile mode (blue), the Game/mobile sound balancer is active and controls the balance of game audio to mobile audio (Rx). Remember that the 9 o'clock position enables each game and mobile audio source to be heard at full volume. Sliding the control **upward** makes game sound louder and mobile audio quieter. Sliding the control **downward** increases mobile volume while making game audio quieter.

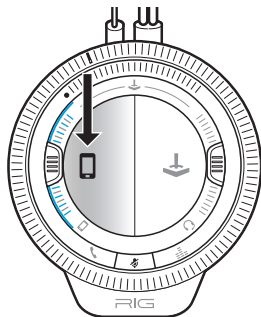

PRO TIP: Most people will prefer game sound to be present while taking a mobile call, but not as loud as when they are playing normally. The best setting for the Game/mobile sound balancer is some where between 9 o'clock and the bottom of the slider travel. This way, game sound is always lowered automatically when deploying the Mic rocker switch to the Mobile mode and accepting a call. If you listen to music while gaming, attenuate the volume by using the control on your mobile device.

Mixing and controlling music from a mobile device

To mix music with game audio, play music from a connected mobile device's music player or any other choice of media app. The Call button on the mixer acts as a play/pause and track forward/back control with most mobile devices.

NOTE *The phone volume must be set loud enough to hear through standard headphones/earbuds in order for the mixer to amplify the sound. A good rule of thumb is to start out from at least 50% or greater volume on the connected mobile device.*

PRO TIP *Music isn't the only thing that can be mixed in and smartphones aren't the only devices that are compatible. Consider the possibilities: watching a Twitch.tv stream via a connected laptop, Skype video chat via connected tablet, and listening and playing along with walkthroughs on YouTube instead of pausing gameplay to watch the video. RIG enables a dedicated mobile channel for audio and chat - take advantage! Play more. Pause less.*

- Take calls. Keep playing. 1 To answer a call from your mobile device while in a game, flip the Mic rocker switch to the Mobile mode (blue) and tap the Call button .

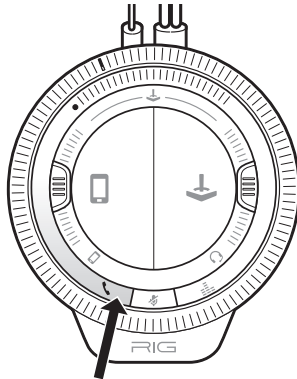

The mixer enables toggling back-and-forth between game chat and mobile calls without disconnecting either conversation. The Mic rocker switch determines which party receives transmission (Tx) from the microphone. In default mode, game chat (Rx) is also **muted** when toggled to the Mobile mode. Mobile audio (Rx) can be heard in both modes.

PRO TIP Answering a phone call by using the connected mobile device is another way to pick up the call, but be sure to flip the Mic rocker switch to the Mobile mode (blue). Remember that the microphone is **muted** to the mobile side unless it is in Mobile mode (blue).

- 2 To end the call, tap the Call button  again. The Mic rocker switch can be in either position when answering or ending a call.
- 3 To make a call from a connected mobile device, flip the Mic rocker switch to the Mobile mode (blue) and dial using the connected device.

Master mute

The Master mute button on the bottom center of the mixer mutes the microphone transmission (Tx) to all connected devices globally. When activated, the button glows red.

PRO TIP The Master mute button will also glow red when the headset jack is disconnected or improperly connected to the mixer. Be certain that the headset jack is fully inserted into the mixer. As the headset connects properly to the mixer, the red light on the Master mute button will automatically shut off.

Equalizer

The equalizer button toggles through three EQ modes.

Press the equalizer button to toggle through the different modes.

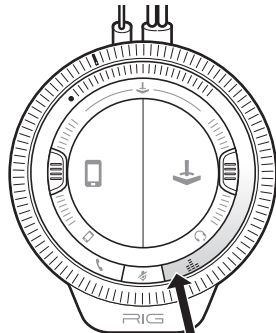

If you press the EQ button	you'll hear	and this will happen
once	1 tone	PURE The Pure mode has only minor audio corrections that enable audio played through the headset as flat and accurate as possible. Use this mode if high-fidelity to the source material is important or preferred.
twice	2 tones	SEISMIC The Seismic Bass Transducers inside of each ear cup of the headset couple with the high energy Seismic EQ mode to elevate low octave audio accurately and powerfully, without coloring important mid-range information-critical for environmental awareness in multiplayer games.
three times	3 tones	INTENSIFY The Intensify mid-range audio boost mode makes mid-range audio sounds much easier to hear. Mid-range audio cues include footsteps, gunshots, and other sounds that give directional information - critical for winning multiplayer matches where audio cues give an extra advantage.

Combo chat

While muting incoming game chat when in Mobile mode seems like desired functionality for most gamers, the mixer can be 'unlocked' to provide game chat to be heard *globally*-or in other words, game chat can still be heard when the Mic rocker switch is set to the Mobile mode (blue).

This feature, called Combo chat, enables all three audio streams (game sound, game chat, and mobile audio) to be managed and heard at all times. The Mic rocker switch merely activates which device the microphone is actively transmitting to. Conversely, if the Mic rocker switch is deployed to the Game mode (orange), for example, microphone transmission is still muted to a connected mobile device, as it is in the default mode.

PRO TIP *While hearing game chat while on a phone call may not seem like an advantageous way to game for some, this feature may uncover additional use cases. Imagine playing a multiplayer game with a large amount of players on the same team, while the critical or desired communication happens within a smaller subset of players (like a squad, or group of friends). With the mixer, the in-game communication (game chat) can be used for 'whole team' chat, and a secondary channel (mobile chat) can be set up on a smartphone or tablet to take advantage of having a private 'side chat' channel for a smaller group of players.*

Activating combo chat mode

With the mixer **powered off**, but still connected to USB power on a compatible device, hold the equalizer button down for 4-5 seconds. **Both** blue and orange LEDs illuminate, indicating that Combo chat mode is now active.

Deactivating combo chat

With the mixer **powered off**, but still connected to USB power on a compatible device, hold the equalizer button down for 4-5 seconds.

Only the orange LED will illuminate, indicating that Combo chat mode is inactive and back to the default mode.

PRO TIP *Combo chat is off as the default mode from the factory, and when the mixer is left unplugged for an extended period of time also reverts it back to the default off mode. Remember, default mode means game chat is muted when the Mic rocker switch is deployed to Mobile mode (blue).*

FAQ

The Mute LED won't turn off.	Make sure 3.5 mm cable is firmly plugged into the mixer.
Callers can't hear me when I answer a phone call.	Make sure the Mic rocker switch is deployed to Mobile mode (blue).
I can't hear the person on the other end of the phone call.	Make sure that the game/mobile sound balancer (the left slider) is set to the midpoint (9 o'clock) or below. Setting this control to the top of the travel balances your audio mix toward game sound, and at the very top, connected mobile devices are effectively muted.
Inline call button doesn't work	The inline cable only works when plugged directly into a smartphone. When plugged into the mixer, use the controls on the mixer. The mixer supersedes the inline controls by design.
I get screeching audio (when using mixer or headset with a phone)	Make certain that all audio jacks are fully and firmly inserted. If the jacks cannot make a proper connection, the headset and mixer will not function correctly. Remember that some bulky smartphone and tablet cases don't allow for some jacks to connect properly.
My phone does not ring through the headset, only through the handset itself.	Some phones, like the Apple iPhone, are designed to ring through the handset to alert the user that a call is incoming when the phone is connected to headphones/earbuds and not in use. If ringing through the headset is the desired behavior, change the handset to silent mode.

Support

EN Tel: 0800 410014	FI Tel: 0800 117095	NO Tel: 80011336
AR Tel: +44 (0)1793 842443*	FR Tel: 0800 945770	PL Tel: +44 (0)1793 842443*
CS Tel: +44 (0)1793 842443*	GA Tel: 1800 551 896	PT Tel: 0800 84 45 17
DA Tel: 80 88 46 10	HE Tel: +44 (0)1793 842443*	RO Tel: +44 (0)1793 842443*
DE Deutschland 0800 9323 400 Österreich 0800 242 500 Schweiz 0800 932 340	HU Tel: +44 (0)1793 842443*	RU Tel: 8-800-200-79-92 Tel: +44 (0)1793 842443*
EL Tel: +44 (0)1793 842443*	IT Tel: 800 950934	SV Tel: 0200 21 46 81
ES Tel: 900 803 666	NL NL 0800 7526876 BE 0800 39202 LUX 800 24870	TR Tel: +44 (0)1793 842443*

**Support in English*

Safety information: see the separate "For Your Safety" booklet

2-year limited warranty details: plantronics.com/warranty

NEED MORE HELP?

plantronics.com/support

plantronics®
Simply Smarter Communications™

Plantronics BV

South Point Building C
Scorpius 140
2132 LR Hoofddorp, Netherlands

© 2014 Plantronics, Inc. All Rights Reserved. Bluetooth is a registered trademark of Bluetooth SIG, Inc. and any use by Plantronics is under license. All other trademarks are the property of their respective owners.

US Patents Pending

201253-06 (03/14)