

acer



Holo360

User's Manual

© 2017 All Rights Reserved
Acer Holo360 User's Manual
Models: C01 / CW01
(C01 - LTE / CW01 - WiFi)
This revision: September 2017

Sign up for an Acer ID and enjoy great benefits

There are three great reasons for you to get an Acer ID:

- Create your own connected world.
- Get the latest offers and product information.
- Register your device for quick, personalized customer support.

For more information, please visit the Acer website: account.acer.com



Important

This manual contains proprietary information that is protected by copyright laws. The information contained in this manual is subject to change without notice. Images provided herein are for reference only and may contain information or features that do not apply to your computer. Acer Group shall not be liable for technical or editorial errors or omissions contained in this manual.

Speaker

This device is equipped with a built-in speaker. Use Bluetooth® technology or insert headphones (not included) for additional privacy.

Acer Holo360 camera

Model number: _____

Serial number: _____

Date of purchase: _____

Place of purchase: _____

TABLE OF CONTENTS

Setting up	4	Direct dial widget	31
Unpacking your camera	4	The voice call screen	31
Getting to know your camera	5	Answering or declining a call	31
Views	5	Conference calls	32
Charging the battery	6	Getting more apps	33
Setting up for the first time	7	Play Store	33
Inserting a microSD card (and optional SIM card)	7	Advanced settings	35
Using your smart camera	8	Wireless & networks	35
Turning on for the first time	8	Network settings	37
Sign in to or create a Google account	8	Display	38
Choose your Mode	9	Adjusting the volume	38
Activating a new SIM card	9	Setting the date and time	38
Using the touchscreen	9	Setting alarms	39
The Lock screen	10	Changing language and text options	39
Waking your camera	10	Connecting to a PC	39
Security Options	10	Synchronization	40
Camera mode	11	Apps (applications)	40
Default mode - Android OS	12	Uninstalling an app	40
Switching to Camera mode	12	Restoring to factory settings	40
Shutting down your camera	12	Accessories and tips	42
Using the Camera	13	Using the headset	42
Icons and indicators	14	Using a Bluetooth headset	42
Camcorder mode	15	Putting your camera in Airplane mode	42
Additional controls	15	Restarting your camera	43
Mode Selector	16	Appendix	44
Picture options menu	16	FAQ and troubleshooting	44
More and Settings menu	17	Audio	44
Taking a photo	18	Multimedia files	44
Shooting a video	18	Google Play Store	45
Viewing photos and videos	18	System information and performance	45
Organizing albums	18	Power	45
Using the Android OS	20	RAM / ROM	45
The Home screen	20	Internal storage	46
Navigation	21	Security	46
Favorites tray	21	Temperature	46
The Apps list	22	Other sources of help	46
Extended Home screens	22	Warnings and precautions	47
Camera access	22	Medical devices	48
Access requests	23	Vehicles	49
Search	23	Potentially explosive environments	49
Status and notification area	25	Emergency calls	50
The virtual keyboard	27	Taking care of your camera	50
Personalizing the Home screen	27	Specifications	52
Making calls	29	Performance	52
Before making a call	29	Display	52
Making a call	29	Dimensions	53
Dialing a number from Call History	29	Connectivity	53
Viewing missed calls	30	Expansion	53
Making a call to one of your contacts	30	Cameras	54
Dialing an international number	30	Power	54
		End User License Agreement	55

SETTING UP

Unpacking your camera

Your new camera comes packed in a protective box. Carefully unpack the box and remove the contents. If any of the following items is missing or damaged, contact your dealer immediately:

- Your new Acer smart camera
- USB cable
- AC adapter
- Card tray ejection tool
- Leather protector case
- Wrist lanyard



Note

In-box content varies depending on country and region.

Getting to know your camera

Views

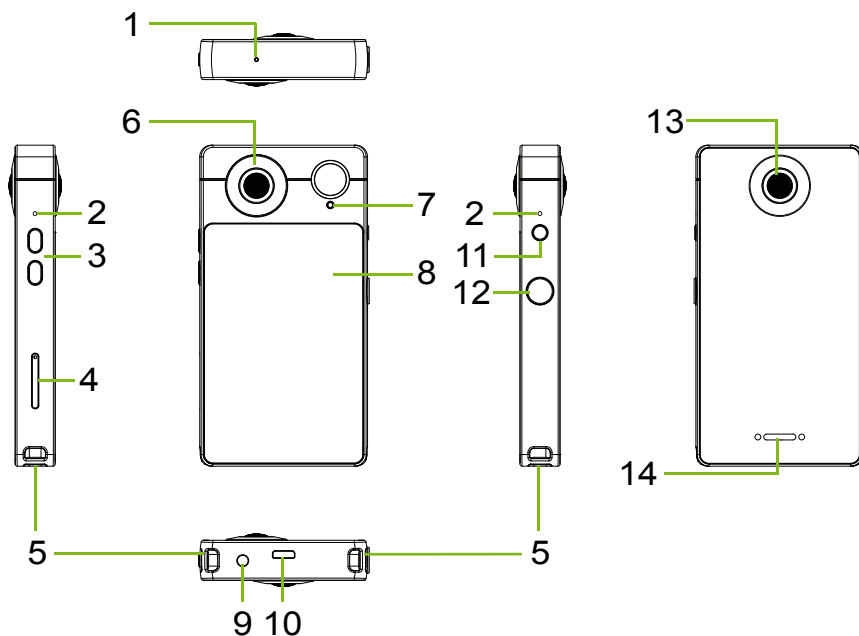

1. Pressure opening

Equalizes pressure inside and outside the camera.

2. Microphone

For capturing audio.

3. Volume up/down buttons

Increase or decrease the audio volume.

Camera app: Adjusts EV.

4. Card tray

Accepts a microSD card and, on certain configurations, a nano SIM card.

5. Strap loop

Attach a wrist or neck strap here.

6. Camera

187° cameras for taking high-resolution images.

7. Power LED

Indicated the power or charging status.

8. Touchscreen

For viewing content from your camera or entering data.

9. 3.5 mm headphone jack

Connects to stereo headphones.

10. Micro USB port

For connecting to a PC or a charger.

11. Power button

Suspends or wakes the camera (long press to turn the camera on or off).

12. Camera button

Opens the Camera app (long press to open the Camera app from suspend).

Camera app: Takes a photo or starts video recording.

13. Camera

187° cameras for taking high-resolution images.

14. Speaker

Emits audio from your camera.

Charging the battery

For initial use, you need to charge your camera for eight hours. After that you can recharge the battery as needed.

Connect the AC adapter cord to the USB connector on your camera.

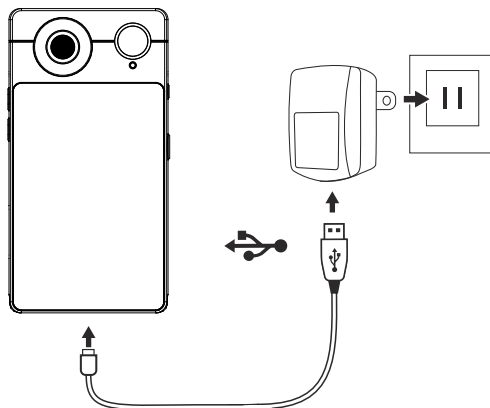

Setting up for the first time

Inserting a microSD card (and optional SIM card)

1. Turn off the camera by pressing and holding the power button.
2. Using the supplied tool, remove the card tray by pressing the tip of the tool into the release hole on the tray.

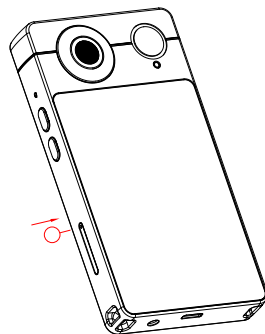

3. Insert a microSD card (and optional SIM card).
4. Replace the tray and press it firmly into place, taking care to ensure that the cards remain properly seated in the tray.

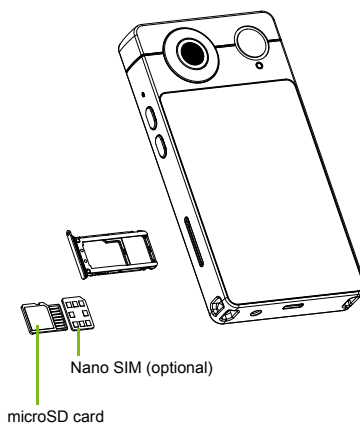

USING YOUR SMART CAMERA

If you are familiar with the Android set up process, then you can jump straight to [Using the Camera on page 13](#).

Turning on for the first time

To turn on your camera, press and hold the power button until you see the Acer logo. Wait a moment for your camera to start. You will then be asked some questions before you can use your camera.

To start, tap to select your language then tap **Let's go**. Follow the rest of the instructions as they are displayed.

If the camera screen turns off, it has entered sleep mode. Briefly press the power button to wake it up. For more information see [Waking your camera on page 10](#).

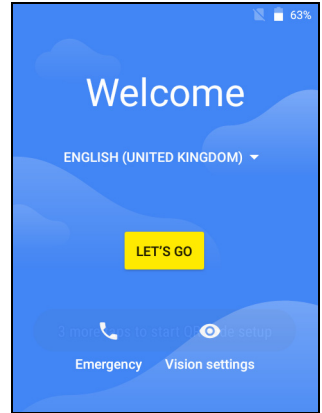

Note

The Emergency call option is only available on LTE models.

Sign in to or create a Google account

If you have Internet access, your camera allows you to synchronize information with a Google account.

During the start-up process, you may create or sign in to an account, which will be used to synchronize your contact list, email, calendar and other information. If you do not yet have Internet access, or do not want to use this feature, then tap **Skip**.



Important

You must sign in to a Google Account to use Gmail, Google Calendar, and some other Google apps; to download apps from Google Play; to back up your settings to Google servers; and to take advantage of other Google services on your camera.

If you have multiple Google accounts, such as separate accounts for personal and business contacts, you can access and synchronize them from the *Accounts* settings section. [See Synchronization on page 40.](#)

Choose your Mode

As you finish the set up process, you may choose to use either **Camera** or **Default** mode.

Camera mode allows you to use the device primarily as a camera, with easy access to camera modes and settings. [See Camera mode on page 11.](#)

Default mode allows your device to act like an Android device, with a camera app that allows you to take photos. [See Using the Android OS on page 20.](#)

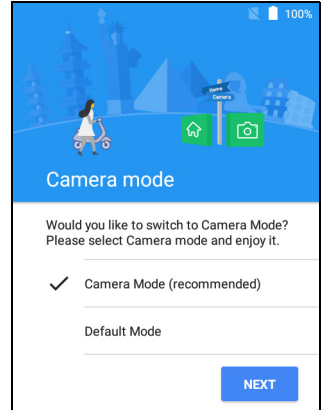

Activating a new SIM card

If you are using your SIM card for the first time (LTE models only), it may require activation. Contact your network operator for details on how to do this.

Using the touchscreen

Your camera uses a touchscreen for selecting items and entering information. Use your finger to tap the screen.

Tap: Touch the screen once to open items and select options.

Swipe: Quickly swipe your finger across the screen to switch screens or open lists of options or information.

Drag: Hold your finger on the screen and drag across the screen to select text and images.

Tap and hold: Tap and hold an item to see a list of actions available for that item. On the pop-up menu that appears, tap the action you want to perform.

Scroll: To scroll up or down the screen, simply drag your finger up or down the screen in the direction that you want to scroll.

The Lock screen

If you will not use your camera for a while, briefly press the power button to lock access. This saves power and ensures your camera does not unintentionally use any services. Your camera will lock automatically if it is not used for one minute.

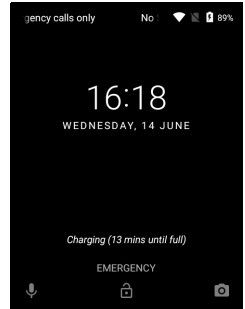

Waking your camera

If the screen is off and the camera does not react to any taps on the screen, then it has been locked and is in sleep mode.

Press the power button to wake your camera. Unlock your camera by sliding your finger upwards across the screen.

There are three icons at the bottom of the lock screen (from left to right): Voice search, lock, and camera. Place your finger on an icon and swipe upwards to unlock the screen or start the associated app.

If there are notifications displayed on the lock screen, you can swipe downwards to view the notifications. Swipe a notification to the left or right to remove it.

Security Options

For additional security, you may set a code or number that must be entered to access the camera, such as an unlock pattern (a set of dots that must be swiped in the correct order) or a PIN. Open the *Apps list* and tap **Settings** > **Security** > **Screen lock**. If you forget your unlock settings, please refer to [Security on page 46](#).

Camera mode

Camera mode provides quick access to camera features. Each screen shows four options; swipe the screen left to see the next screen.



Tap an icon to open use your camera. For more information about the camera app see [Using the Camera on page 13](#).

First screen:

- Take a 360° image.
- Take a 360° video.
- Take a Panoramic photo.
- Take a Panoramic video.

Second screen:

- Open the *HoloGallery* to view images.
- Take a time-lapse video.
- Add your location and a weather report to a photo.
- Use settings for improved night-time shots.

Third screen:

- Open the *App List*
- Custom app shortcuts.
 - Open the *App List* then tap and hold an app to replace a '+' icon with an app shortcut.

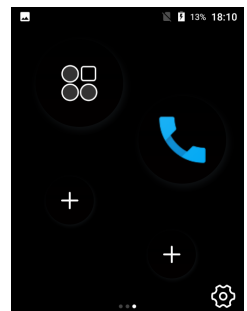

Note

If you add more than three shortcuts then a fourth screen will be added with additional spaces for app shortcuts.

Settings

Tap the *Settings* icon to change the wallpaper, or to switch the *Startup screen*. Select *HoloLauncher* for Camera mode or *Launcher3* for Default mode.

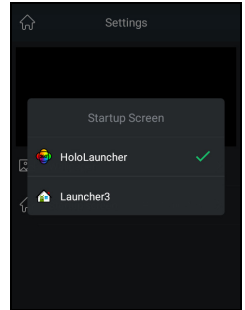

Status and notifications

Swipe down from the top of the screen to display Quick Settings shortcuts, and notification details. **See Status and notification area on page 25.**

Default mode - Android OS

If you need any help using the Android features of your Smart camera, please **see Using the Android OS on page 20.**

Switching to Camera mode

From the Home screen, open the *Apps List* and select **HL Settings**. Tap **Startup screen**, then **HoloLauncher**.

Shutting down your camera

If you won't use your camera for an extended period of time, turn it off to save battery power. To turn off your camera (even when locked), press and hold the power button until a menu displays (about one second). Tap **Power off** and confirm the shut down. To force a shutdown, press and hold the power button until the camera shuts down (about four seconds).

USING THE CAMERA

Your smart camera features two 187° cameras mounted on the front and on the rear, which can combine to create a 360° image of your surroundings.

To activate the camera:

- if you are in *Camera mode* (see **Camera mode on page 11**), tap an icon from the Home screen.
- swipe the camera icon up from the Lock screen,
- open **HoloCamera** from the *Apps list* or the *Favorites tray*, or
- swipe right from the Home screen.



HoloCamera

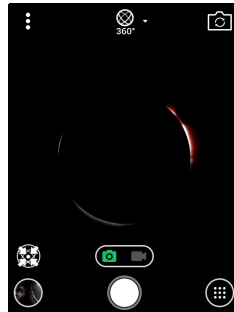

You can view photos or videos (and other images on your camera) in the *HoloGallery* app. Open the *HoloGallery* app from the Home screen or tap the thumbnail of the last image in the corner of the *HoloCamera* screen. See **Viewing photos and videos on page 18**.



HoloGallery

Icons and indicators

The camera window provides multiple controls on the image screen.

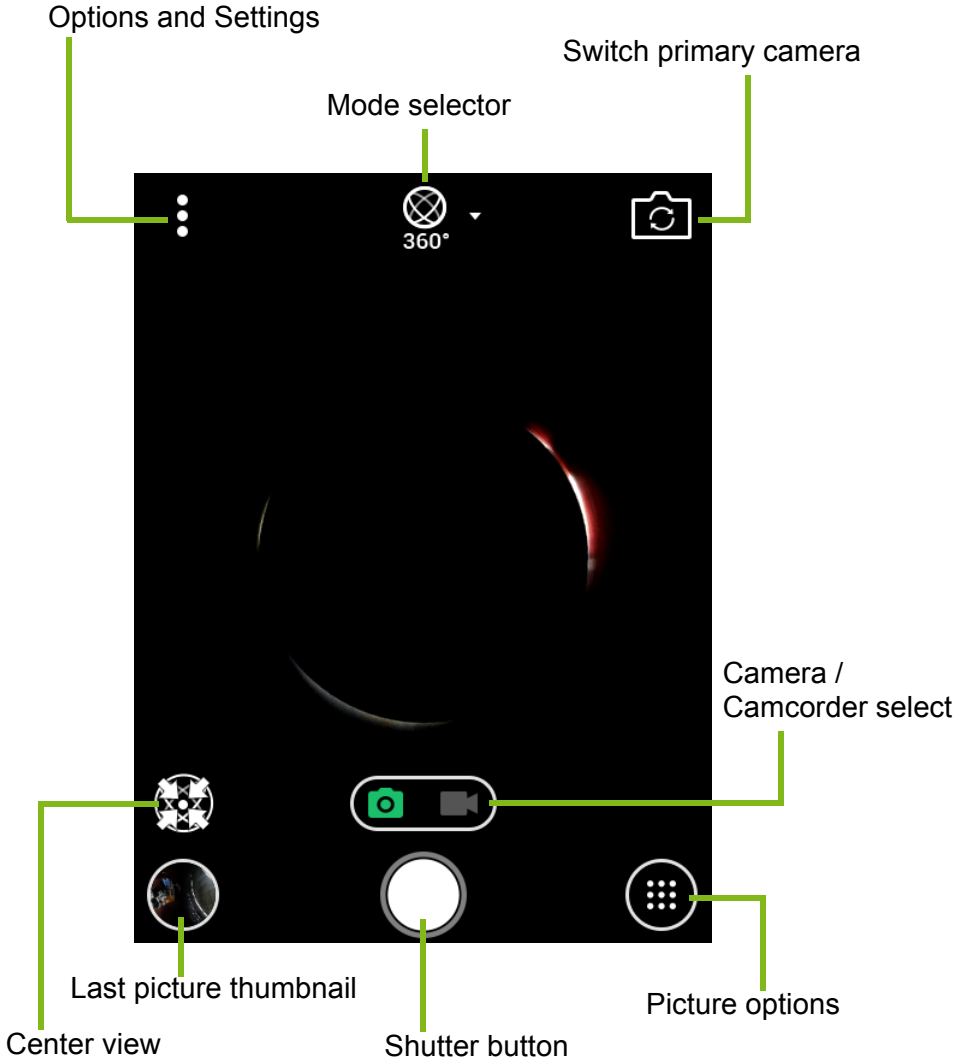

Tap the **Shutter** button or press the **Camera** button to take a picture. Tap the thumbnail image to open the gallery.

In 360° mode, drag the photo image to move the central focus of the image. Tap *Center view* to return to the default view.

Camcorder mode

Tap the *Camera / Camcorder* switch to enter camcorder mode. Tap the shutter to begin filming. While filming, you are unable to access most settings.

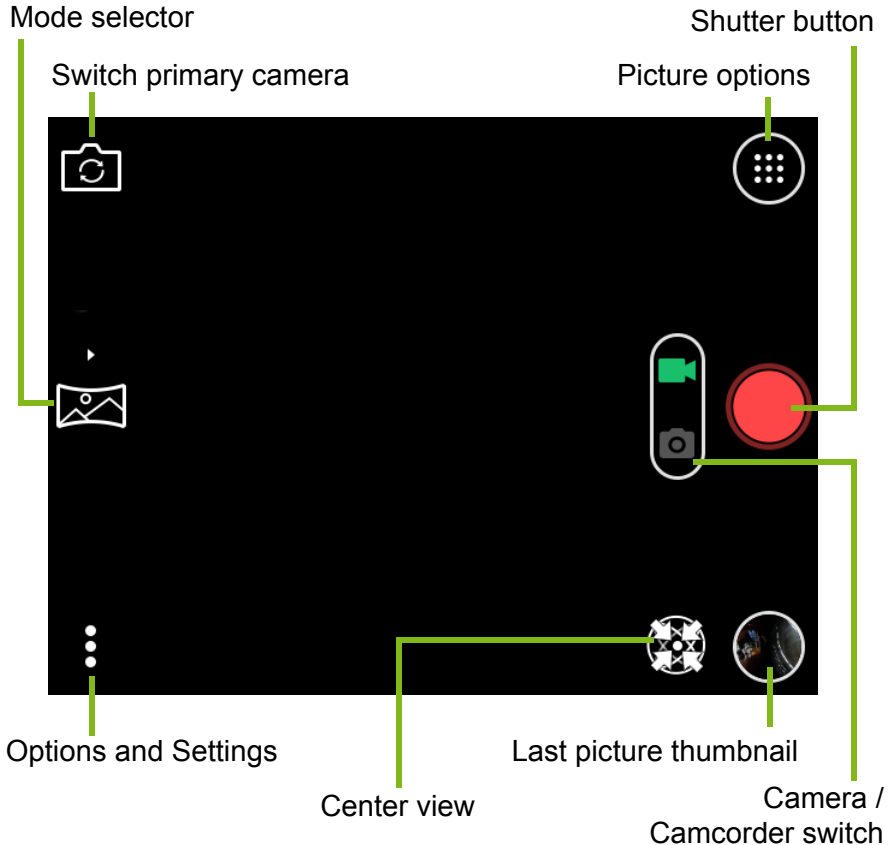

While filming, tap the camera icon next to the *Shutter* button to capture a photo of the scene.

Tap the *Shutter* button again to stop filming.

Additional controls

The volume buttons on the side of the camera adjust EV levels (brightness).

Press and hold the camera button to switch between camera and camcorder modes.

Mode Selector

Tap the *Mode selector* icon to open a list of modes. Tap an icon to select a mode.

Modes

360° - Take a 360° image, using both camera lenses.

Panorama - Take a wide panorama image.

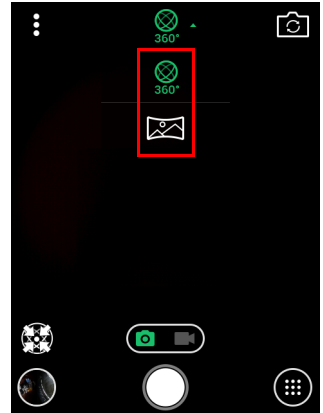

Picture options menu



Note

Some options are not available in all camera or video modes.

Tap the *Picture options* icon to see options.

Auto - Use automatic settings for best results.

Night - Use settings for improved night-time shots.

I'm here - Add text with your location and a weather report to a photo (camera only).

Slow motion - capture video at a higher speed so playback will be in slow motion (video only).

Time lapse - capture video at a slower speed so playback will be accelerated (video only). Tap the icon to change the delay between captures frames (2 - 10 seconds).



More and Settings menu



Note

Some options or settings are not available in all camera or video modes.

Tap the *More* icon to view some image options and *Settings*. Tap an icon to turn that feature on or off (described below), or tap the *Settings* icon for more settings.

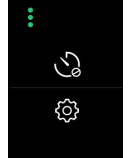

Timer

Set a delay of 3, 5, or 10 seconds before the image is taken.

Settings

General settings

Power saving mode - adjust screen and power settings to increase battery life when the battery is low.

Location - store the location in the image data.

Storage - store images and video on the internal memory or an SD card (if installed).

Capture settings

Stabilizer - turn stabilization on or off.

Continuous shot - tap and hold the shutter button to take a series of rapid-fire images.

Grid - display a grid on the camera screen.

Video settings

Video stabilizer - turn stabilization on or off.

Audio mode - turn audio on or off (normal or mute).

Reset

Restore all settings to their original values.

Taking a photo

1. If necessary, adjust the settings described above.
2. Frame your subject and steady your camera.
3. Tap the **Shutter** button to take a picture.

Shooting a video

1. Tap the **Camcorder** button to switch camcorder mode.
2. Frame your subject and steady your camera and zoom in or out as needed.
3. Tap the **Shutter** button to start taking a video. Tap the **Shutter** button to stop recording video.

Viewing photos and videos

After you have taken your photo or video, it is automatically saved; you can view it in *HoloGallery* by tapping the thumbnail in the corner of the screen or by opening the *HoloGallery* app.



HoloGallery

HoloGallery allows you to view 360° images. Tap on an image to open it. You can swipe to move your point of view and zoom into any point in the image.

Organizing albums

Tap the text at the top of the screen to organize your images into **Times** or **Locations**.



Note

To organize by Location, turn on the Location setting before taking photos or videos. See Settings on page 17.

After selecting an album, you may choose to view the **360 Raw** images (images and videos taken in 360° mode), or **Collections** of standard images and videos.

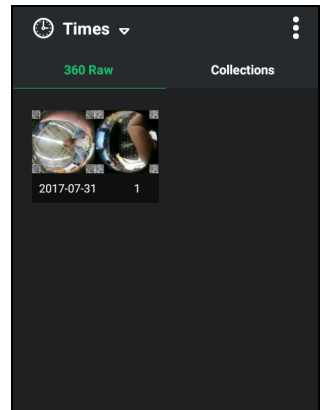

Tap the **Thumbnail** or **Filmstrip** view to change how the images are displayed.



Tap an image to open it, or tap and hold to select it; once an image is selected, tap other images to add them to the selection. After selecting images, you may choose to share them with another app, or delete them.

You may also edit photos you have taken by tapping the pencil icon  on the screen (not available for 360° images).

When viewing a 360° image, you may change the display mode. Tap the icon at the top of the screen to switch cameras (360° image only) or convert the image to a panoramic view.

Create Time-lapse

With certain image you may select several images and combine them into a single time-lapse movie. Tap the **Options** button and select **Create Time-lapse**. The select images for the time-lapse, an order and then save the file to your camera.



Back up & sync

You may use the *HoloGallery* app to upload images to online cloud services. Tap the **Options** button and select **Back up & sync**. Choose an account (or accounts) from the list, and sign in if necessary.



Additional settings allow you to choose if videos are also backed up, and the type of network used to send files.

USING THE ANDROID OS

If you are not familiar with the Android OS, then you can find some information about using the Home screen and apps.

The Home screen

When you start your camera, or wake it from power saving, it will display the *Home screen*. This screen gives you quick access to apps ("applications"), widgets, and folders.

The *Home screen* provides controls and information

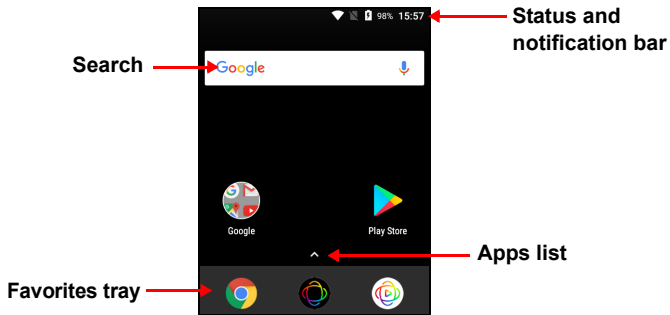

At the bottom of the screen is the *Favorites tray* which displays useful apps. Tap an icon to open the app. Tap the arrow above the *Favorites tray* to view more apps. To change which apps are in the favorites tray, [see Changing Favorites tray icons on page 21](#).



Note

You may tap and hold certain apps to open a list of shortcuts to common tasks; for example, tap and hold the **Play Store** icon to open the **My Apps** section of the app.

Drag the icon normally to move or remove it.

Navigation

To navigate through menus and options, there are three touch-sensitive buttons beneath the screen.



Back

Tap this button to go to the previous page, or to go up one level in a menu.

Home

Tap this button to go directly to the *Home screen*. Tap and hold this icon to open *Google search*.

Overview / Recent

Tap this button to see recently opened apps in your camera's *Overview* screen. Tap an app to open it. Tap anywhere on the screen to return to the *Home screen*.

Previous app

Double tap the *Overview* button to switch to your previously used app.

Favorites tray

The *Favorites tray* is visible on any *Home screen* and holds apps you frequently use.

Changing Favorites tray icons

You can set icons for installed apps in the *Favorites tray*. Find the app you want to add and tap and hold the icon, then drag it to any open position in the *Favorites tray*. Dragging the new app to an existing *Favorites tray* icon will create a folder for both icons.

To remove an icon from the *Favorites tray*, tap and hold the icon to select it. Either drag the icon to a different location outside the *Favorites tray* or to **Remove** at the top of the screen.

The Apps list

To access the *Apps list*, on the *Home screen* tap the arrow above the center of the *Favorites tray*.

Apps are displayed in alphabetical order, with the four most-recently used apps at the top of the menu. Swipe up or down to see the complete list of apps.

You can copy an icon and move it to a Home screen for quick access. Tap and hold an app then drag it up to a Home Screen. Release your finger to place the app. **See [Moving an app or folder on page 27](#)**.

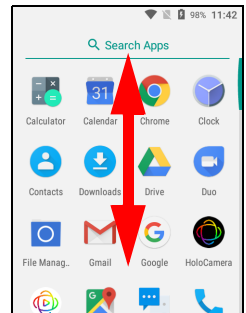

Extended Home screens

The *Home screen* can be extended to the right of the main Home screen, giving you more room to add icons or widgets. To add a screen, drag an icon or widget to the right edge of the screen. To view the extended screen, swipe to the left.

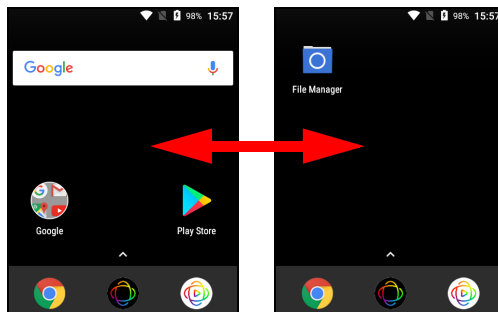

Note

Extended screens to the right are only available if you have added content to the right of the Home screen.

Camera access

To activate the camera (**see [Using the Camera on page 13](#)**):

- swipe the camera icon up from the Lock screen,

- open **HoloCamera** from the *Apps list* or the *Favorites tray*, or
- swipe right from the Home screen.

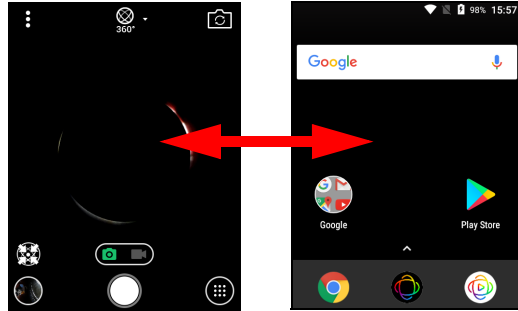

Access requests

When you first open some apps, or use certain functions, your camera will ask for permission to access some features or information.

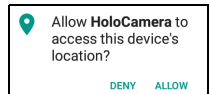

To allow the app to fully function tap **Allow** or **OK**, but if you do not want to share some information you can choose to **Cancel** or **Deny** access; however this may cause some apps to function incorrectly. To change permissions later, open the app information in **Settings** > **Apps**, then tap **Permissions** to turn permissions on or off.

Search

Search enables you to use a single, quick search to locate a variety of information on the internet and on your camera. To use *Search*, simply tap **Google** in the search bar and type your query.







Note

In order to search or browse the internet, you must be connected to a wireless network. See Getting more apps on page 33.

Searching on the internet

As you type, a list displays search suggestions. Based on the words you enter, these suggestions try to help you quickly access what you are looking for and may include the following:

-  A previous search you performed on any device while you were logged into your Google account and performed a Google search;
-  A new internet search suggesting what you might be looking for;
-  A specific website address.

If what you're looking for appears in the suggestions list, simply tap it. Otherwise, tap  on the keyboard.

Tap a category at the top of the results screen to filter the search results to show just *Images*, *News*, or other type of result.

Searching on your camera

Camera search results are shown below the internet search suggestions. These suggestions are taken from sources such as the names of apps installed on your camera, settings, media files from Google Play apps, contacts, bookmarks, and browsing history.



Note

*You can choose what information is included in camera searches. Open the **Google** app and tap the Menu icon  in the top-left corner of the screen. Then tap **Settings** > **In apps**.*

Voice search and "OK Google"

With voice actions, you can send text messages, place calls, send emails, find directions, search the internet and even send a note to yourself using your voice. Say "OK Google" or open the *Apps list* and tap **Voice Search**.



Note

Voice Search is available only in selected regions.

Status and notification area

Status and notification icons are shown at the top of the screen. The top-right corner displays status information such as the time, battery status, and connectivity. The top-left corner displays event notifications, such as new message alerts.

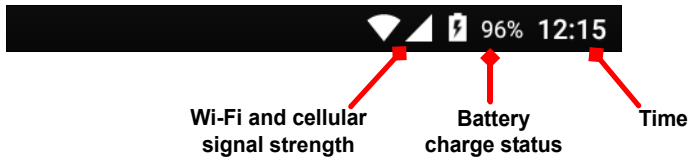

Swipe down from the top of the screen to display Quick Settings shortcuts, and notification details such as current downloads and media controls when music is playing.

Tap a shortcut to see more information, or toggle the feature if more information is not available. Tap and hold a shortcut to open appropriate *Settings*.









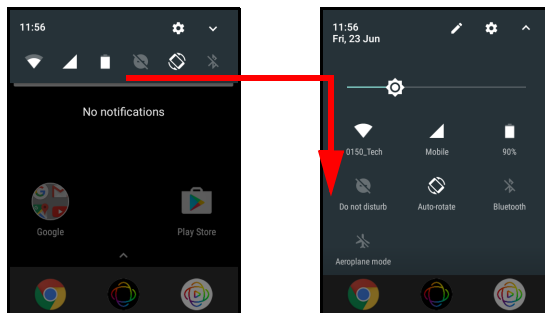

Note

Cellular signal strength is only available on LTE models.

Swipe down again to display the full list of *Quick Settings* tiles. To see the *Quick Settings* tiles with one swipe, swipe down with two fingers.



Quick Settings tiles

Icon	Name	Description
	Brightness	Slide to adjust the screen's brightness.
	Wi-Fi	Tap to toggle Wi-Fi and display Wi-Fi settings. Small "up" and "down" arrows mean information is being transmitted.
	SIM (LTE models only)	Tap to toggle phone and data connections and display SIM settings.
	Battery usage	Tap to see battery charge levels and access <i>Battery Saver</i> settings.
	Do not disturb	Tap to silence some or all notifications or alarms.
	Auto rotate	Tap to toggle automatic screen rotation on and off.
	Bluetooth	Tap to toggle Bluetooth on and open Bluetooth settings.
	Airplane mode	Tap to toggle Airplane mode on and off. When on, wireless connectivity is turned off unless you choose to turn a network on again.



Note

Tap and hold a tile to open related settings.

Edit

Tap  to see more *Quick Settings* tiles. Tap and hold a tile and drag to add, remove or move it. The first five tiles are visible in the Quick Settings shortcuts.

Notifications

Tap a notification to open the appropriate app; tap and hold a notification to see additional controls.

The virtual keyboard

When you tap a text box to enter text, a virtual keyboard will appear. Simply tap on keys to enter text.

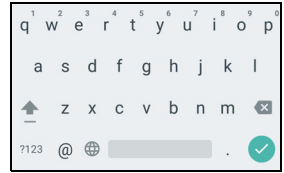

Note

The keyboard layout varies slightly, depending on the application and information that is required.

Tap the **?123** button to see numbers and special characters, and then tap the **=\<** key to see more options. Tap and hold a key to select alternative characters (if available for that key), such as letters with accents or related symbols.

Personalizing the *Home screen*

You can personalize your *Home screen* by moving apps, adding or removing widgets, creating folders and by changing the wallpaper.

Moving an app or folder

Tap and hold an app or folder you want to move. For certain apps, to view information about the app, drag it to **App info** at the top of the screen. Otherwise, drag the icon and release your finger to place the app.

To place the app on an different *Home screen*, do the following:

1. Slide your finger to the right or left side of the screen.



Note

*You may not place icons to the left of the main *Home screen*.*

2. Hold the app there until you are on the desired *Home screen*.

3. Release your finger to place the app.

Removing apps from a Home screen

To remove a downloaded app from the *Home* screen, tap and hold the item until the **Uninstall** option appears at the top of the screen. Simply drag the item to the **Uninstall** option and tap **OK**.



Note

You may only uninstall downloaded apps. Apps that were preinstalled on your camera may not be removed.

Adding folders to a Home screen

You can also add folders to your *Home* screen. To create a new folder drag and drop an app icon onto another app icon. This will create an "Unnamed Folder". Tap the folder icon and then tap the name of the folder to rename it.

To remove an app shortcut from a folder, tap on the folder icon to display the apps inside and then tap and hold the app icon that you want to remove. Drag and drop the icon to a new position. If you remove all but one shortcut, the folder will be removed.

Adding widgets to a Home screen

Tap and hold any open space on a *Home* screen, then tap **Widgets**. To move a widget to the *Home* screen, tap and hold an item until it is selected. The *Home* screen will open. Drag the item to any free area on the screen.

Removing widgets from a Home screen

To remove an item from the *Home* screen, tap and hold the item until the **Remove** option appears at the top of the screen. Simply drag the item to the **Remove** option.  Remove

MAKING CALLS

Certain models of the smart camera may make phone calls. Other models may use messaging services that provide calls over the internet; see the messaging app's help for more information.



Note

Cellular calls are only available on LTE models with an installed SIM card.

Before making a call

Check that the phone function is on before you make a call. You can confirm the phone status from the notification area.

Icon	Description
	Connected to the network: You may make a call.
	Airplane mode: Wireless connectivity disconnected (Wi-Fi, Bluetooth, and cellular). Please disable airplane mode before trying to make a call.

Making a call

1. From the *Home screen* tap **Phone** then to open the onscreen number pad.
2. Enter the number you wish to dial.
3. Tap to make the call.
4. To end the call, tap .

If the contact you need is displayed, simply tap the contact name to make a call.

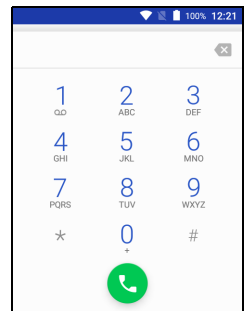

Dialing a number from Call History

Your call history can be viewed by tapping the *Call History* icon. It displays recent received, dialed, and missed calls.

Tap the phone icon to redial. To view call details and other options, tap the number or contact's name.

Viewing missed calls

Missed call notifications are displayed in the following three areas:

1. The Notification area with the missed call  icon. Open the **Notification** area and tap the missed call notification to display the missed call details.
2. By the Phone icon (the number in the box is the number of missed calls). Tap **Phone** from either the *Home screen* or the *Apps list* to directly display the missed call details.
3. On your camera's lock screen. Double-tap the notification to display the missed call details.



Making a call to one of your contacts

Calling a contact from the Contacts tab

1. Tap the **All contacts** to view your contacts.
2. Tap on a contact to call them.

Calling a contact from the Contacts app

1. Tap the **People** icon the *Apps list* to view your contacts.
2. Tap on a contact to open their profile.
3. Tap on the contact's phone number to call them.

Dialing an international number

When dialing international numbers, there is no need to enter the international direct dialing prefix ('00' etc.) before the country code. Tap and hold 0+ on the number pad until + appears onscreen.



Important

International call rates can vary greatly depending on the country you are calling and your network provider. We suggest you check all call rates with your network provider, to avoid excessive phone bills. If you use phone or data features abroad, roaming charges will apply. Consult your network provider for roaming rates specific to the country you are visiting before you leave.

Direct dial widget

You may add a direct dial widget for a contact on your *Home screen*. Open the *Apps list*, then tap the **Widgets** tab. Find *Contacts*, then tap and hold **Direct dial** and you will be able to place the widget on your *Home screen*. Once placed, you will be able to select which of your contacts to place on your *Home screen*.

The voice call screen





Answering or declining a call

When you have an incoming call, the number will be shown on the screen. To accept or decline the call, tap and hold the phone icon in the middle of the screen, then slide your finger across the screen towards one of the three icons that appear.

Ending a call

To end a call, tap  from the voice call screen.

Voice call options



Icon	Description
	Place the call on hold.
	Mute a call.
	Speakerphone.
	Access the keypad while a call is in progress.
	One option: <ul style="list-style-type: none"> • Add a second call

Saving a dialed number to contacts

You can save a number you have dialed to your contacts for future use. From the *Call History* , tap the number and then tap **Create new contact** and enter the information. Alternatively you can tap **Add to a contact** to update an existing contact's information.

Conference calls

If you have one call on hold and another on line, you can combine both calls to create a conference call.

After the first call is established, tap  to add a second call. Tap  to start the conference call.

GETTING MORE APPS

Play Store



Important

For connection issues with Play Store, see [FAQ and troubleshooting on page 44](#).

Tap **Play Store** to open the *Google Play* app. Here you can obtain a variety of apps to enhance your camera.

The contents and design of *Google Play* varies by region. For example, in some regions, you can also browse for and purchase movies, books, magazines, or music. Updates may add new categories or change how to navigate *Google Play* at any time.

You can browse the store by category or tap the search icon to search for a specific app.

Once you have selected an app, tap **Install** to download and install the app. You will be told which services the app requires access in order to function correctly (e.g. contact information, wireless access, GPS). If none of these services seem unusual, tap **Accept & download** to proceed with the installation.

You may keep track of the download progress from both the app's page and the notification area.

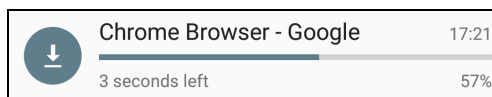
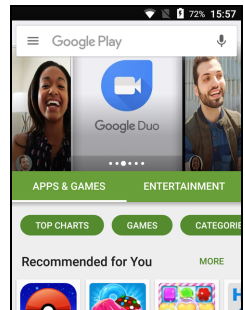

Important

Some apps may require payment before you can download them. You will need to have a [Google Wallet account](#) in order to pay for these apps, or a credit card number associated with your Google account.

Using downloaded apps

Once you've downloaded and installed an app, you may find it in the *Apps list* or *Widgets list*.

Certain apps provide both an App and widget, or only provide a widget (with no app icon). **See Personalizing the Home screen on page 27.**

Uninstalling downloaded apps

Once you've downloaded and installed an app, you may uninstall the app by opening the *Apps list* and tapping **Settings** > **Apps**. Scroll through the list of apps and select the app you wish to uninstall. Tap **UNINSTALL**.

ADVANCED SETTINGS

To access **Settings**, open the *Apps list* and tap **Settings**.

To quickly navigate with a list of main categories, swipe in from the left of the screen.

Wireless & networks

Open the *Apps list* and tap **Settings** to manage your connection settings.

Item	Description
Wi-Fi	Turn the Wi-Fi function on or off.
Bluetooth	Turn the Bluetooth function on or off.
Data usage	View an estimate of the mobile data used for your SIM.
More...	<p>Access additional connection settings:</p> <p>Airplane mode: Disable all wireless connections so you can safely use this device onboard an aircraft.</p> <p>Tethering & portable hotspot: Share your camera's mobile data connection via USB or as a portable Wi-Fi hotspot.</p> <p>VPN: Set up and manage Virtual Private Networks.</p> <p>Cellular/Mobile networks: Set your options for connecting to cellular networks.</p> <p>Network settings reset: Reset all Wi-Fi, Cellular and Bluetooth settings.</p>

If your camera is in Airplane mode, the option to turn Bluetooth on will be disabled. Please refer to [Putting your camera in Airplane mode on page 42](#) for instructions on turning Airplane mode on or off.

Adjusting Bluetooth settings

You can use Bluetooth to exchange information between your camera and other mobile devices.

Bluetooth connections

For all Bluetooth settings, open the *Apps list* and tap **Settings > Bluetooth**. Tap the toggle switch next to turn Bluetooth on or off. When you turn Bluetooth on, your camera will automatically search for any nearby devices that are discoverable. Your camera will be discoverable as long as you have the Bluetooth settings open.

To connect to a device, tap the device in the list of available devices. You may be asked to enter a PIN on both devices to establish the connection.

To quickly turn on or off Bluetooth, open the **Notification** area and tap the **Bluetooth** icon.

Internet sharing

Tethering via USB

If you wish to share your mobile internet connection with a computer, you can connect your camera to a PC using the supplied USB cable.

1. Plug the USB sync cable into the USB connector on your camera.
2. Plug the USB client connector into an available USB port on your computer.
3. Open **Settings > More... > Tethering & portable hotspot > USB tethering** to turn USB internet sharing on or off.

Wi-Fi hotspot

You can turn your camera into a portable Wi-Fi hotspot to share your mobile internet connection with up to eight clients.

1. Open **Settings > More... > Tethering & portable hotspot > Portable Wi-Fi hotspot**.
2. Tap **Set up Wi-Fi hotspot**, and change the *Network name*, security, and password as necessary. Tap **SAVE** to finish.



Note

When your camera is serving as a Wi-Fi hotspot, you can only access the internet via your camera's data connection, and you may incur data charges.

Network settings

In the *Apps list* tap **Settings** > **More...** > **Cellular networks** to adjust your network settings. You can turn data connection on or off when roaming, choose a preferred network type, specify a network operator and define access point names.

Selecting a network

Your camera will automatically detect your carrier/network settings when you insert a new SIM card. However, you may prefer to manually select a network when roaming.



Note

When you are traveling, manually selecting a network may help to reduce your roaming charges. Check with your home service provider for the network offering the most competitive rates at your destination.

1. Open the *Apps list* and tap **Settings** > **More...** > **Cellular networks** > **Network operators** > **Search networks**.
2. Your camera will search for available networks.
3. Select your preferred network from the list generated. Your camera will attempt to register on the selected network.
4. Tap **Select automatically** to connect to the available network with the strongest signal. This may lead to your camera jumping between networks when you move around.



Note

Contact your service provider should you have any problems obtaining voice mail and the text message service center numbers.

Data Usage (background data)

The *Data Usage* section shows how much data has been transmitted to your tablet, either in total or for each app. This information is useful if you are using a metered service.

If an app is using too much data, or you need to control how your data service is used, open the **Data Usage** menu, and turn *Data Saver* on. Tap to see a list of apps installed on your device, you may disable background data for individual apps. An app controlled by the *Data*

Saver will only be able to access to a data connection when you're actively using the app.



Note

Blocking background data may cause some apps to stop working correctly. For example, background data is required to make regular checks for updates, useful for email or messenger apps.

Phone settings

Many phone settings are automatically configured by your camera when you insert a SIM card. The device will communicate with your provider and automatically obtain all necessary settings, such as network name, voice mail and text message center numbers.

Display

To adjust your camera's display settings, in the *Apps list* tap **Settings** > **Display**.

You can also adjust the screen brightness, turn casting or screen rotation on or off from *Quick Settings*.

Adjusting the volume

Adjust the volume of your camera using the volume button on the side of the camera. Alternatively, you can set the Ringtone, Notifications, and Alarms volume by opening **Settings** > **Sound** and then adjusting the sliders under *Sound*.

Setting the date and time

To set the date and time, open **Settings** > **Date & time**.

If you travel frequently or live in an area that uses daylight saving time, tap **Automatic date & time** and **Automatic time zone** to turn them both on. This will enable your camera to set the date and time based on information it receives from the network.

Setting alarms

There are two predefined alarms on your camera by default. Open **Clock** from the *Apps list*, and then tap  to view the alarms. Tap and hold an alarm to change its settings. You may:

- Turn the alarm on or off.
- Set the alarm time.
- Set which days to repeat the alarm.
- Set a ringtone.
- Enable or disable vibrate.
- Give it a label.

Changing language and text options

Set your location and language input preferences by opening **Settings > Language & input**.

Connecting to a PC

If you wish to transfer information between your device and your computer (either the microSD card in your device or the device's internal memory), you can connect your device to a PC using the supplied USB cable.

1. Plug the USB sync cable into the USB connector on your camera.
2. Plug the USB client connector into an available USB port on your computer.
3. Open the notification area and tap **USB charging this device** then choose **Transfer files**.

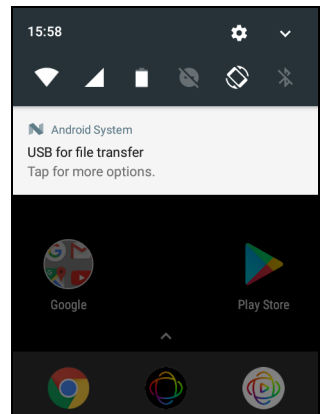

Your device will now be available as a drive in your computer's file explorer.

Synchronization

You can sync your calendar, email and contacts on your camera and never worry about losing them again. Sync in real time or adjust it as you please. Open **Settings** > **Accounts** > [*account name*] to access the synchronization settings.

To add a new account, tap **Add account**. Select the type of account and then follow the onscreen instructions.

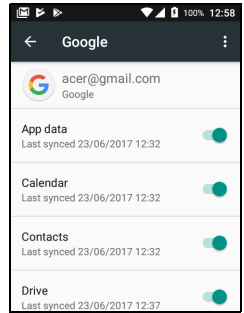

Google Sync

In Google, you can set synchronization for Google services. In your Google account's synchronization settings menu, tap the item you would like to have auto-sync. Tap again for manual synchronization.

To manually synchronize an item, make sure toggle switch next to the item is turned on, tap the **Menu** icon  and then tap **Sync now**.



Note

You need a Google account to sync your calendar and appointments.

Apps (applications)

Uninstalling an app

You can remove programs you have downloaded and installed to free up extra storage memory. From the *Apps list*, tap and hold the app you wish to uninstall, and then drag it to "Uninstall" at the top of the screen. You will be asked to confirm the uninstall; tap **OK**.



Important

Can only uninstall apps that you have downloaded.

Restoring to factory settings

You may perform a clean boot to restore your camera to the factory settings. Before performing a clean boot, ensure that your camera is

not locked. Press any button or tap the screen to see if the camera responds.



Important

You should only perform a clean boot when all other options have failed to restore your camera to an operational state.

This will erase all your personal information, any contacts stored on your camera and any programs you installed.

If your camera is responding to screen input, then open **Settings** from the *Apps list*. Tap **Backup & reset > Factory data reset > Reset camera** and then **Erase everything** to format your camera.

ACCESSORIES AND TIPS

This chapter shows you how to use accessories with your camera, as well as provide useful tips for when you are using your camera.

Using the headset

Your camera is compatible with headsets with built-in microphone for handsfree use when making calls.

To use the headset, plug it into the 3.5 mm headphone jack on the side of the camera.

When the headset is plugged in, all audio is routed to the headset, and the speakers are turned off.

- To answer an incoming call, press the button on the microphone.
- Adjust the volume using the volume up/down button on the camera.
- End the call by pressing the button again.

Using a Bluetooth headset

Your camera's Bluetooth functions make it fully compatible with all Bluetooth headsets. This allows you to use the unit hands-free when making calls, without the inconvenience of wires. [See Bluetooth connections on page 36.](#)

Putting your camera in Airplane mode

You can enable Airplane mode (also known as flight mode) to turn off cellular, Wi-Fi and Bluetooth functions and use your camera as a handheld device during a flight. Check with your airline to make sure this is permitted onboard.

Switch your camera off during takeoff and landing as it may interfere with aircraft electronic systems.

Open *Quick Settings* and tap  *Airplane mode*.

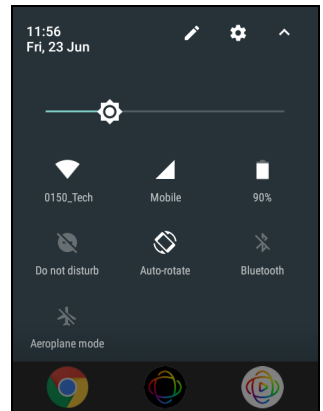

Restarting your camera

You can restart ('reboot') your camera if you find apps are not responding.

1. Press and hold the power button until you get the camera options menu.
2. Tap **Reboot**.

APPENDIX

FAQ and troubleshooting

This section lists frequently asked questions that may arise during the use of your camera, and gives easy answers and solutions to these questions.

Audio

Question	Suggestions
Why is there no sound coming from the device?	<p>If the headset is plugged into the device, the speaker is automatically shut off. Disconnect the headset.</p> <p>Check that the device volume setting is not muted.</p> <p>Check that the volume control is not at its lowest setting.</p>

Multimedia files

Question	Suggestions
Why can't I view my picture files?	You may be trying to view an image that is not supported. Try a different app.
Why can't I view my video files?	You may be trying to view a video that is not supported. Try a different app.
Why can't I play my music files?	You may be trying to play a file that is not supported. Try a different app.

Google Play Store

Question	Suggestions
Why can't I connect to the Play Store?	<ol style="list-style-type: none"> 1. First check that you have a Wi-Fi or data connection (some Wi-Fi "hotspots" require you to log in before accessing the internet) and then try again. 2. If you still cannot connect, try adjusting your date/time settings. Open Settings > Date & time and turn Automatic date & time off. 3. Manually adjust the time and then try to reconnect to the Play Store.

System information and performance

Question	Suggestions
How do I check the OS version of my device?	Tap Settings > About camera to check the OS version (Build number) and other hardware and software information.

Power

Question	Suggestions
I can't turn on the device.	The battery power may be depleted. Recharge the device. See Charging the battery on page 6 for more information.

RAM / ROM

Question	Suggestions
How do I check memory status?	To check storage status, go to Settings > Storage .

Internal storage

Question	Suggestions
My device's available internal storage is full or almost full.	Uninstall apps to increase available storage. See Uninstalling an app on page 40.

Security

Question	Suggestions
I forgot my unlock pattern.	After a certain number of wrong entries, you will be presented with an option to reset your pattern. Tap Forgot pattern? and enter your Google account username and password. <i>You must have an active Google account on the camera.</i> Alternatively, you restore your camera to factory settings. See Restoring to factory settings on page 40.

Temperature

Question	Suggestions
The camera heats up when charging or making long duration calls.	It is normal for the camera to heat up when charging. When charging is complete, it will return to its normal temperature. It is also normal for the camera to heat up during long periods of use, such as watching a video or a long phone conversation.

Other sources of help

For information on	Refer to ...
Up-to-date information regarding your camera	www.acer.com mobile.acer.com
Service enquiries	www.acer.com/support

WARNINGS AND PRECAUTIONS

- Do not use this product near water.
- Do not place this product on an unstable cart, stand or table. If the product falls, it could be seriously damaged.
- Slots and openings are provided for ventilation to ensure reliable operation of the product and to protect it from overheating. These openings must not be blocked or covered. The openings should never be blocked by placing the product on a bed, sofa, rug or other similar surface. This product should never be placed near or over a radiator or heat register, or in a built-in installation unless proper ventilation is provided.
- Never push objects of any kind into this product through cabinet slots as they may touch dangerous voltage points or short-out parts that could result in a fire or electric shock. Never spill liquid of any kind onto or into the product.
- To avoid damage of internal components and to prevent battery leakage, do not place the product on a vibrating surface.
- Never use this product when engaging in sporting activities, exercising, or in any vibrating environment which may cause a short circuit or damage, and even a risk of explosion from the battery pack.

Protecting your hearing

To protect your hearing, follow these instructions.

- Increase the volume gradually until you can hear clearly and comfortably.
- Do not increase the volume level after your ears have adjusted.
- Do not listen to music at high volumes for extended periods.
- Do not increase the volume to block out noisy surroundings.
- Decrease the volume if you can't hear people speaking near you.

Additional safety information

Your device and its enhancements may contain small parts. Keep them out of the reach of small children.

Operating environment



Important

For safety reasons, turn off all wireless or radio transmitting devices when using your camera device under the following conditions. These devices may include, but are not limited to: Wireless LAN (WLAN), Bluetooth and/or cellular.

Remember to follow any special regulations in force in any area, and always switch off your device when its use is prohibited or when it may cause interference or danger. Use the device only in its normal operating positions. To successfully transmit data files or messages, this device requires a good quality connection to the network. In some cases, transmission of data files or messages may be delayed until such a connection is available. Ensure that the above separation distance instructions are followed until the transmission is completed. Parts of the device are magnetic. Metallic materials may be attracted to the device, and persons with hearing aids should not hold the device to the ear with the hearing aid. Do not place credit cards or other magnetic storage media near the device, because information stored on them may be erased.

Medical devices

Operation of any radio transmitting equipment, including wireless cameras, may interfere with the functionality of inadequately protected medical devices. Consult a physician or the manufacturer of the medical device to determine if they are adequately shielded from external RF energy or if you have any questions. Switch off your device in health care facilities when any regulations posted in these areas instruct you to do so. Hospitals or health care facilities may be using equipment that could be sensitive to external RF transmissions.

Pacemakers. Pacemaker manufacturers recommend that a minimum separation of 15.3 cm (6") be maintained between wireless devices and a pacemaker to avoid potential interference with the pacemaker. These recommendations are consistent with the independent research by and recommendations of Wireless Technology Research. Persons with pacemakers should do the following:

- Always keep the device more than 15.3 cm (6") from the pacemaker.
- Not carry the device near your pacemaker when the device is switched on. If you suspect interference, switch off your device, and move it.

Hearing aids. Some digital wireless devices may interfere with some hearing aids. If interference occurs, consult your service provider.

Vehicles

RF signals may affect improperly installed or inadequately shielded electronic systems in motor vehicles such as electronic fuel injection systems, electronic anti-skid (anti-lock) braking systems, electronic speed control systems, and air bag systems. For more information, check with the manufacturer, or its representative, of your vehicle or any equipment that has been added. Only qualified personnel should service the device, or install the device in a vehicle. Faulty installation or service may be dangerous and may invalidate any warranty that may apply to the device. Check regularly that all wireless equipment in your vehicle is mounted and operating properly. Do not store or carry flammable liquids, gases, or explosive materials in the same compartment as the device, its parts, or enhancements. For vehicles equipped with an air bag, remember that air bags inflate with great force. Do not place objects, including installed or portable wireless equipment in the area over the air bag or in the air bag deployment area. If in-vehicle wireless equipment is improperly installed, and the air bag inflates, serious injury could result. Using your device while flying in aircraft is prohibited. Switch off your device before boarding an aircraft. The use of wireless teledevices in an aircraft may be dangerous to the operation of the aircraft, disrupt the wireless telephone network, and may be illegal.

Potentially explosive environments

Switch off your device when in any area with a potentially explosive atmosphere and obey all signs and instructions. Potentially explosive atmospheres include areas where you would normally be advised to turn off your vehicle engine. Sparks in such areas could cause an explosion or fire resulting in bodily injury or even death. Switch off the

device at refueling points such as near gas pumps at service stations. Observe restrictions on the use of radio equipment in fuel depots, storage, and distribution areas; chemical plants; or where blasting operations are in progress. Areas with a potentially explosive atmospheres are often, but not always, clearly marked. They include below deck on boats, chemical transfer or storage facilities, vehicles using liquefied petroleum gas (such as propane or butane), and areas where the air contains chemicals or particles such as grain, dust or metal powders.

Follow any restrictions. Do not use the device where blasting is in progress.

Emergency calls



Important

Wireless cameras, including this device, operate using radio signals, wireless networks, landline networks, and user-programmed functions. Because of this, connections in all conditions cannot be guaranteed. You should never rely solely on any wireless device for essential communications like medical emergencies.

If certain features are in use, you may first need to turn those features off before you can make an emergency call. Consult this guide or your service provider for more information.

When making an emergency call, give all the necessary information as accurately as possible. Your wireless device may be the only means of communication at the scene of an accident. Do not end the call until given permission to do so.

Taking care of your camera

1. **DO** take care not to scratch the screen of your camera. Keep the screen clean. When working with your camera, use your finger or fingernail. Never use an actual pen or pencil or other sharp object on the screen surface.
2. **DO NOT** expose your camera to rain or moisture. Do not let water enter the circuitry. In general, treat your camera as you would any other small electronic device.

3. **DO** be careful not to drop your camera or subject it to any strong impact. Do not place your camera in your back pocket.
4. **DO NOT** expose your camera to extreme temperatures. For example, do not leave your camera on the dashboard of a car on a hot day or when temperatures are below freezing point. Also, keep it away from heaters and other sources of heat.
5. **DO NOT** use or store your camera in any location that is dusty, damp or wet.
6. **DO** use a soft, damp cloth to clean your camera. If the surface of the screen becomes soiled, clean it with a soft cloth moistened with diluted window-cleaning solution.
7. **DO NOT** press down on the screen with force, otherwise you may crack the screen.

SPECIFICATIONS

Notes

To avoid scratching the lens, do not lay the device flat without protection.

Do not apply pressure to the fisheye lens.

Battery note

This device is equipped with a built-in battery. Please do not attempt to remove the battery yourself as this may damage the battery and could lead to potential overheating, personal injury and malfunction. The battery must only be removed or replaced by an authorized Acer service center.

Should the device become unresponsive, hold down the power button for 10 seconds to switch off the device.

Certification

To view safety and regulatory information, open **Settings** on the device, tap **About device**, then **Certification Logo**.



Note

Specifications may vary depending on region and configuration.

Performance

- Qualcomm Snapdragon 625
 - Octa-core processor (MSM8953 2.0 GHz)
- System memory:
 - 2 GB of RAM
 - 16 GB of ROM
- Android operating system

Display

- 3" IPS LCD, capacitive touchscreen
- 640 x 480 resolution
- 16.7M colors

- 370 nits (before touch panel)

Dimensions

Height	110 mm
Width	57.6 mm
Thickness	13.6 mm
Weight	139 g (with battery)

Connectivity

- Bluetooth 4.1 + LE
- IEEE 802.11a/b/g/n/ac (2.4 GHz and 5 GHz)
- GPS, with aGPS support and SUPL

Cellular connectivity (C01 model only)

Nano SIM slot

- 4G LTE
 - EU, AAP, TW models: 2100 (B1) / 1800 (B3) / 2600 (B7) / 900 (B8) / 800 (B20) / 700 (B28)
 - PA models: 1900 (B2) / AWS (B4) / 850 (B5) / 2600 (B7) / 700 (B12 / B17)
- HSPA+/WCDMA
 - EU, AAP, TW models: 2100 (B1) / 1900 (B2) / 850 (B5) / 900 (B8)
 - PA models: 2100 (B1) / 1900 (B2) / AWS (B4) / 850 (B5)
- LTE FDD/TDD R9 Cat4 150/50 Mbps
- HSDPA up to 42 Mbps, HSUPA up to 11 Mbps



Note

Frequencies and bands supported vary depending on model.

Expansion

- microSD memory card slot (up to 128 GB; SDHC 2.0 compatible, exFAT)

- Micro USB connector

Cameras

- 16 MP front & rear cameras
 - 187-degree viewing angle each
 - 4K video recording

Power

- Adapter
 - AC input: 100 to 240 V, 50 or 60 Hz
 - DC output: 5 V, 1 A
 - Micro USB connector
- 2000 mAh nominal-rated Li-polymer battery
 - Not user-replaceable



Note

Length of battery operation will depend on power consumption which is based on system resource use. For example, constantly using the backlight or using power-demanding apps will shorten battery life between charges.

END USER LICENSE AGREEMENT

IMPORTANT-READ CAREFULLY: THIS END USER LICENSE AGREEMENT ("AGREEMENT") IS A LEGAL AGREEMENT BETWEEN YOU (EITHER AN INDIVIDUAL OR A SINGLE ENTITY), AND ACER INC. INCLUDING ITS SUBSIDIARIES ("ACER") FOR THE SOFTWARE (WHETHER PROVIDED BY ACER OR BY ACER'S LICENSORS OR SUPPLIERS) THAT ACCOMPANIES THIS AGREEMENT, INCLUDING ANY ASSOCIATED MEDIA, PRINTED MATERIALS AND RELATED USER ELECTRONIC DOCUMENTATION WHICH MAY BE BRANDED "ACER" ("SOFTWARE"). AGREEMENTS RELATING TO ANY OTHER PRODUCT OR TOPIC ARE NEITHER INTENDED NOR SHOULD THEY BE IMPLIED. BY INSTALLING THE ACCOMPANYING SOFTWARE OR ANY PORTION THEREOF, YOU AGREE TO BE BOUND BY THE TERMS AND CONDITIONS OF THIS AGREEMENT. IF YOU DO NOT AGREE TO ALL OF THE TERMS AND CONDITIONS OF THIS AGREEMENT, DO NOT CONTINUE THE INSTALLATION PROCESS AND IMMEDIATELY DELETE ALL INSTALLED FILES, IF ANY, OF THE ACCOMPANYING SOFTWARE FROM YOUR DEVICE.

IF YOU DO NOT HAVE A VALIDLY-LICENSED COPY OF THE APPLICABLE SOFTWARE, YOU ARE NOT AUTHORIZED TO INSTALL, COPY OR OTHERWISE USE THE SOFTWARE, AND HAVE NO RIGHTS UNDER THIS AGREEMENT.

The Software is protected by U.S. and international copyright laws and conventions as well as other intellectual property laws and treaties. The Software is licensed, not sold.

GRANT OF LICENSE

Acer grants to you the following non-exclusive and non-transferable rights with respect to the Software. Under this Agreement, you may:

1. Install and use the Software only on a single designated device. A separate license is required for each device on which the Software will be used;
2. Make one copy of the Software solely for backup or archival purposes;
3. Make one hardcopy of any electronic documents included in the Software, provided that you receive the documents electronically.

RESTRICTIONS

You may NOT:

1. Use or copy the Software except as provided in this Agreement;
2. Rent or lease the Software to any third party;
3. Modify, adapt, or translate the Software in whole or in part;
4. Reverse engineer, decompile, or disassemble the Software or create derivative works based upon the Software;
5. Merge the Software with any other program or modify the Software, except for your personal use; and
6. Sublicense or otherwise make the Software available to third parties, except that you may, after prior written notification to Acer, transfer the Software as a whole to a third party so long as you do not retain any copies of the Software and such third party accepts the terms of this Agreement.
7. Transfer your rights under this Agreement to any third parties.
8. Export the Software in contravention of applicable export laws and regulations, or (i) sell, export, re-export, transfer, divert, disclose technical data, or dispose of, any Software to any prohibited person, entity, or destination including, without limitation, Cuba, Iran, North Korea,

Sudan and Syria; or (ii) use any Software for any use prohibited by the laws or regulations of the United States.

SUPPORT SERVICES

Acer is not obligated to provide technical or other support for the Software.

ACER LIVE UPDATE

Certain of the software contains elements that enable the use of the Acer Live Update service, which allows for updates for such software to be automatically downloaded and installed on your device. By installing the software, you hereby agree and consent that Acer (or its licensors) may automatically check the version of such software that you are using on your device and may provide upgrades to such software that may be automatically downloaded on to your device.

OWNERSHIP AND COPYRIGHT

Title, ownership rights and intellectual property rights in and to the Software and all copies thereof shall remain with Acer or Acer's licensors or suppliers (as applicable). You do not have or shall not gain any proprietary interest in the Software (including any modifications or copies made by or for you) or any related intellectual property rights. Title and related rights in the content accessed through the Software is the property of the applicable content owner and may be protected by applicable law. This license gives you no rights to such contents. You hereby agree

1. Not to remove any copyright or other proprietary notices from the Software;
2. To reproduce all such notices on any authorized copies you make; and
3. To use best efforts to prevent any unauthorized copying of the Software.

TRADEMARKS

This Agreement does not grant to you any rights in connection with any trademarks or service marks of Acer or of Acer's licensors or suppliers.

DISCLAIMER OF WARRANTIES

TO THE MAXIMUM EXTENT PERMITTED BY APPLICABLE LAW, ACER, ITS SUPPLIERS, AND ITS LICENSORS, PROVIDE THE SOFTWARE "AS IS" AND WITH ALL FAULTS, AND HEREBY DISCLAIM ALL OTHER WARRANTIES AND CONDITIONS, EITHER EXPRESS, IMPLIED OR STATUTORY, INCLUDING, BUT NOT LIMITED TO, ANY IMPLIED WARRANTIES, DUTIES OR CONDITIONS OF MERCHANTABILITY, OF FITNESS FOR A PARTICULAR PURPOSE, OF ACCURACY OR COMPLETENESS OF RESPONSES, OF RESULTS, OF WORKMANLIKE EFFORT, OF LACK OF VIRUSES, AND OF LACK OF NEGLIGENCE, ALL WITH REGARD TO THE SOFTWARE AND THE PROVISION OF OR FAILURE TO PROVIDE SUPPORT SERVICES. ALSO, THERE IS NO WARRANTY OR CONDITION OF TITLE, QUIET ENJOYMENT, QUIET POSSESSION, CORRESPONDENCE TO DESCRIPTION OR NON-INFRINGEMENT WITH REGARD TO THE SOFTWARE.

EXCLUSION OF INCIDENTAL, CONSEQUENTIAL AND CERTAIN OTHER DAMAGES

TO THE MAXIMUM EXTENT PERMITTED BY APPLICABLE LAW, IN NO EVENT SHALL ACER, ACER'S SUPPLIERS, OR ACER'S LICENSORS, BE LIABLE FOR ANY SPECIAL, INCIDENTAL, INDIRECT, PUNITIVE, OR CONSEQUENTIAL DAMAGES WHATSOEVER (INCLUDING, BUT NOT LIMITED TO, DAMAGES FOR LOSS OF PROFITS OR CONFIDENTIAL OR OTHER INFORMATION, FOR BUSINESS INTERRUPTION, FOR PERSONAL INJURY, FOR LOSS OF PRIVACY, FOR FAILURE TO MEET ANY DUTY INCLUDING OF GOOD FAITH OR OF REASONABLE CARE, FOR NEGLIGENCE, AND FOR ANY OTHER PECUNIARY OR OTHER LOSS WHATSOEVER) ARISING OUT OF OR IN ANY WAY RELATED TO THE USE OF OR INABILITY TO USE THE SOFTWARE, THE PROVISION OF OR FAILURE TO PROVIDE SUPPORT SERVICES, OR OTHERWISE UNDER OR IN CONNECTION WITH ANY PROVISION OF THIS AGREEMENT, EVEN IN THE EVENT OF THE FAULT, TORT (INCLUDING

NEGLIGENCE), STRICT LIABILITY, BREACH OF CONTRACT OR BREACH OF WARRANTY OF ACER OR ITS SUPPLIERS OR LICENSORS, AND EVEN IF ACER AND ITS SUPPLIERS AND LICENSORS HAVE BEEN ADVISED OF THE POSSIBILITY OF SUCH DAMAGES.

LIMITATION OF LIABILITY AND REMEDIES

NOTWITHSTANDING ANY DAMAGES THAT YOU MIGHT INCUR FOR ANY REASON WHATSOEVER (INCLUDING, WITHOUT LIMITATION, ALL DAMAGES REFERENCED ABOVE AND ALL DIRECT OR GENERAL DAMAGES), THE ENTIRE LIABILITY OF ACER, ITS SUPPLIERS, AND ITS LICENSORS, UNDER ANY PROVISION OF THIS AGREEMENT, AND YOUR EXCLUSIVE REMEDY FOR ALL OF THE FOREGOING, SHALL BE LIMITED TO THE AGGREGATE AMOUNT PAID BY YOU FOR THE SOFTWARE. THE FOREGOING LIMITATIONS, EXCLUSIONS AND DISCLAIMERS (INCLUDING DISCLAIMER OF WARRANTIES AND EXCLUSION OF INCIDENTAL, CONSEQUENTIAL AND CERTAIN OTHER DAMAGES ABOVE) SHALL APPLY TO THE MAXIMUM EXTENT PERMITTED BY APPLICABLE LAW, EVEN IF ANY REMEDY FAILS ITS ESSENTIAL PURPOSE; PROVIDED, HOWEVER, THAT BECAUSE SOME JURISDICTIONS DO NOT ALLOW THE EXCLUSION OR LIMITATION OR LIABILITY FOR CONSEQUENTIAL OR INCIDENTAL DAMAGES, THE ABOVE LIMITATION MAY NOT APPLY TO YOU.

TERMINATION

Without prejudice to any other rights, Acer may immediately terminate this Agreement without notice if you fail to comply with any terms and conditions of this Agreement.

In such event, you must:

1. Cease all use of the Software;
2. Destroy or return to Acer the original and all copies of the Software; and
3. Delete the Software from all devices on which it was resident.

All disclaimers of warranties and limitation of liability set forth in this Agreement shall survive termination of this Agreement.

GENERAL

This Agreement represents the complete agreement between you and Acer relating to this license for the Software and supersedes all prior agreements, communications, proposals and representations between the parties and prevails over any conflicting or additional terms of any quote, order, acknowledgement or similar communication. This Agreement may only be modified by a written document signed by both parties. If any provision of this Agreement is held by a court of competent jurisdiction to be contrary to law that provision will be enforced to the maximum extent permissible and the remaining provisions of this Agreement will remain in full force and effect.

ADDITIONAL PROVISIONS APPLICABLE TO THIRD PARTY SOFTWARE AND SERVICES

Software provided hereunder by Acer's licensors or suppliers ("Third Party Software") is made available to you for your personal, non-commercial use only. You may not use the Third Party Software in any manner that could damage, disable, overburden, or impair the services provided by Acer's licensors or suppliers hereunder ("Third Party Services"). Furthermore, you may not use the Third Party Software in any manner that could interfere with any other party's use and enjoyment of the Third Party Services, or the services and products of Acer's licensors' or suppliers' third party licensors. Your use of the Third Party Software and Third Party Services is also subject to additional terms and conditions and policies which can be accessed through our global website.

Privacy policy

During registration you will be asked to submit some information to Acer. Please refer to Acer's privacy policy at www.acer.com or your local Acer website.