

Overview

Introduction

HP Notebook Stands include a range of convenient solutions and space-saving designs that easily connect to your HP Business Notebook and enable easy viewing and an ideal desktop computing environment.

Models

HP Adjustable Dual Display Stand	AW664AA
HP Display and Notebook II Stand New!	E8G00AA
HP Display and Notebook Stand	AW662AA
HP Dual Hinge II Notebook Stand New!	E8F99AA
HP Dual Hinge Notebook Stand	AW661AA
HP Adjustable Display Stand	AW663AA
HP LCD Monitor Stand	QM196AA
HP Single Monitor Arm	BT861AA

HP Adjustable Dual Display Stand (AW664AA)

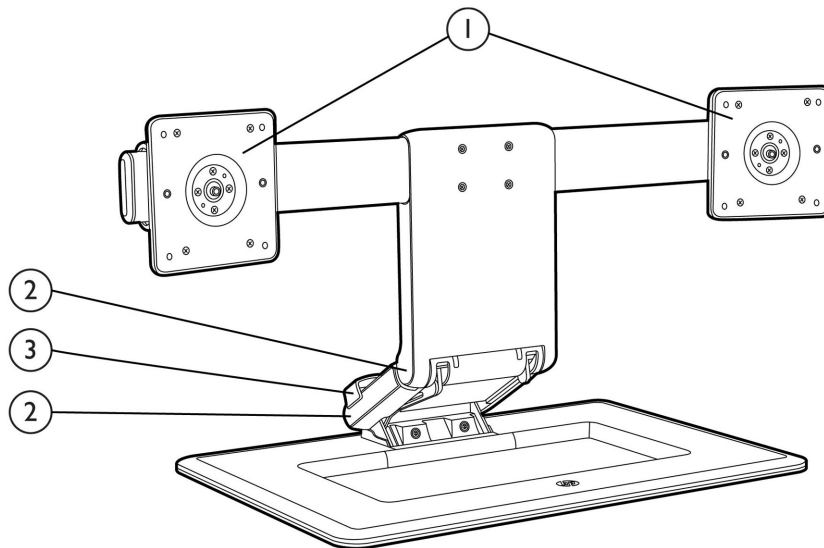

1. VESA display mounts
2. Dual-hinged

3. Cable management channel

Overview

	Rev B	Rev A
Dimensions (H x W x D)	15.7 x 19.7 x 14.0 in (40.0 x 50.0 x 35.5 cm)	15.7 x 19.7 x 14.0 in (40.0 x 50.0 x 35.5 cm)
Product weight	12.3 lb (5.6 kg)	12.3 lb (5.6 kg)
Maximum individual monitor weight	5.0-13.2 lbs. (2.3-6.0 Kg)	7.28-15.4 lbs. (3.3-7.0 kg)
Compatible displays	HP LCD display up to 24" with 100mm or 75mm VESA mounting pattern	HP LCD display up to 24" with 100mm VESA mounting pattern
Dual-hinged display stand	The dual-hinged, smooth-motion display stand allows for greater distance, height, and tilt adjustment for maximum comfort.	
Cable management channels	Organizes and hides accessory cables in a central location to help reduce clutter when connecting multiple devices.	
Service and support	One-year limited warranty. Additional support is available 24 hours a day, seven days a week by phone as well as online support forums. NOTE: Certain restrictions and exclusions apply. Consult the HP Customer Support Center for details.	
Kit contents	Base, riser, bow, two(2) sliding monitor brackets, hardware kit and documentation	

HP Display and Notebook II Stand (E8G00AA)

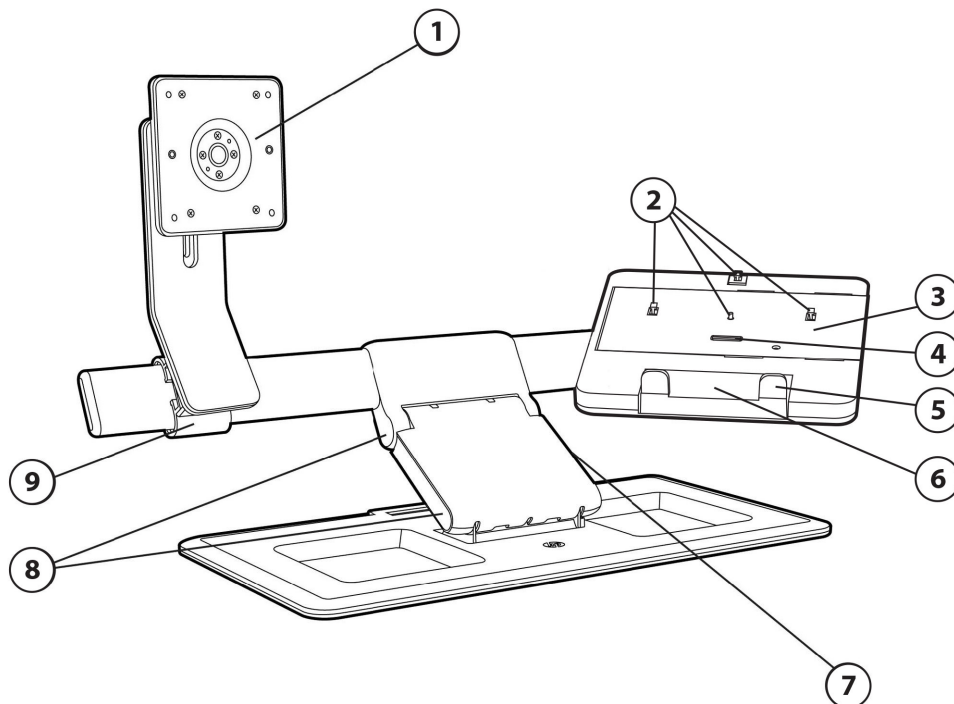

1. VESA display mounts
2. Docking posts
3. Convertible platform
4. Eject button
5. Notebook Platform
6. Cable management channel (not shown)
7. Dual-hinged
8. Horizontal adjustment bracket
9. Horizontal adjustment bracket

Overview

5. Adjustable shelf

Dimensions (H x W x D)	18.9 x 27.2 x 18.5.0 in (48.0 x 69.0 x 47.0 cm)
Product weight	14.9 lbs. (6.8 kg)
Weight capacity	8.8-26.9 lbs. (4.0-12.2kg) Display up to 13.2 lbs. (6.0 kg); notebooks 3.7-7.7 lbs. (1.7-3.5 kg); docks up to 6 lbs. (2.7kg)
Maximum monitor weight	5.0-13.2 lbs. (2.3-6.0 Kg)
Compatible displays	HP LCD display up to 24" with 100mm or 75mm VESA mounting pattern
Notebooks supported	12-17.3"
Docks supported	HP 90W/230W Docking Stations, 120w/230W Advanced Docking Stations, UltraSlim Docks, 2570p Docking Station.
Dual-hinged display stand	The dual-hinged, smooth-motion display stand allows for greater distance, height, and tilt adjustment for maximum comfort.
Horizontal adjustment bracket	Adjusts the horizontal position of your display.
Adjustable shelf	Adjusts for different-sized notebook PCs.
Docking posts	Aligns and secures the docking station to the stand.
Removable convertible platform	Three-way convertible platform allows user to switch between HP 90W/230W Docking Stations, 120w/230W Advanced Docking Stations, UltraSlim Docks, 2570p Docking Station or no dock configuration
Cable management channels	Organizes and hides accessory cables in a central location to help reduce clutter when connecting multiple devices.
Service and support	One-year limited warranty. Additional support is available 24 hours a day, seven days a week by phone as well as online support forums. NOTE: Certain restrictions and exclusions apply. Consult the HP Customer Support Center for details.
Kit contents	Stand, notebook platform, one height-adjustable sliding monitor bracket, hardware kit and documentation. Ships assembled in the Basic/Advanced Dock configuration

HP Display and Notebook Stand (AW662AA)

Overview

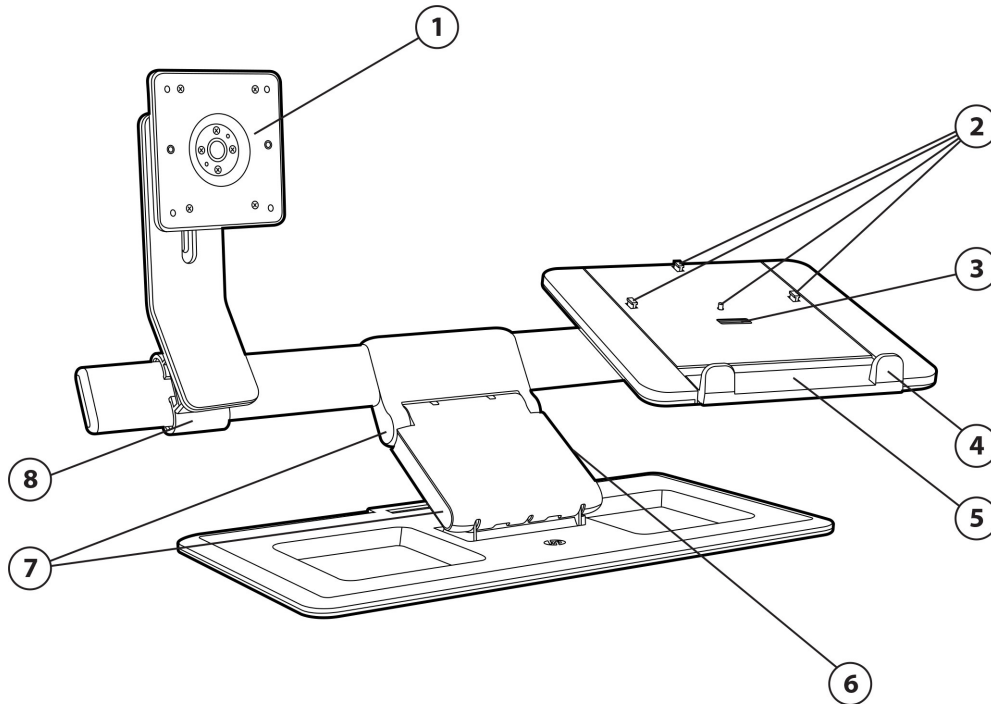

- 1. VESA display mounts
- 2. Docking posts
- 3. Eject button
- 4. Adjustable shelf

- 5. Notebook platform
- 6. Cable management channel (not shown)
- 7. Dual-hinged
- 8. Horizontal adjustment bracket

Dimensions (H x W x D) 18.9 x 27.2 x 18.5 in (48.0 x 69.0 x 47.0 cm)
Product weight 14.6 lbs. (6.6 kg)
Weight capacity 11.0-29.1 lbs. (5.0-13.2 kg)
Display up to 14.3 lbs. (6.5 kg); notebooks 3.7-7.7 lbs. (1.7-3.5 kg); docks up to 6 lbs. (2.7kg)

Maximum monitor weight 7.28-15.4 lbs. (3.3-7.0 kg)

Compatible displays HP LCD display up to 24" with 100mm VESA mounting pattern

Notebooks supported 12-17.3"

Docks supported HP 90W/230W Docking Stations, 120w/230W Advanced Docking Stations, 2570p Docking Station

Dual-hinged display stand The dual-hinged, smooth-motion display stand allows for greater distance, height, and tilt adjustment for maximum comfort.

Horizontal adjustment bracket Adjusts the horizontal position of your display.

Adjustable shelf Adjusts for different-sized notebook PCs.

Docking posts Aligns and secures the docking station to the stand.

Cable management channels Organizes and hides accessory cables in a central location to help reduce clutter when connecting multiple devices.

Overview

Service and support

One-year limited warranty. Additional support is available 24 hours a day, seven days a week by phone as well as online support forums.

NOTE: Certain restrictions and exclusions apply. Consult the [HP Customer Support Center](#) for details.

Kit contents

Stand, notebook platform, universal docking notebook platform cover, one height-adjustable sliding monitor bracket, hardware kit and documentation

HP Dual Hinge II Notebook Stand (E8F99AA)

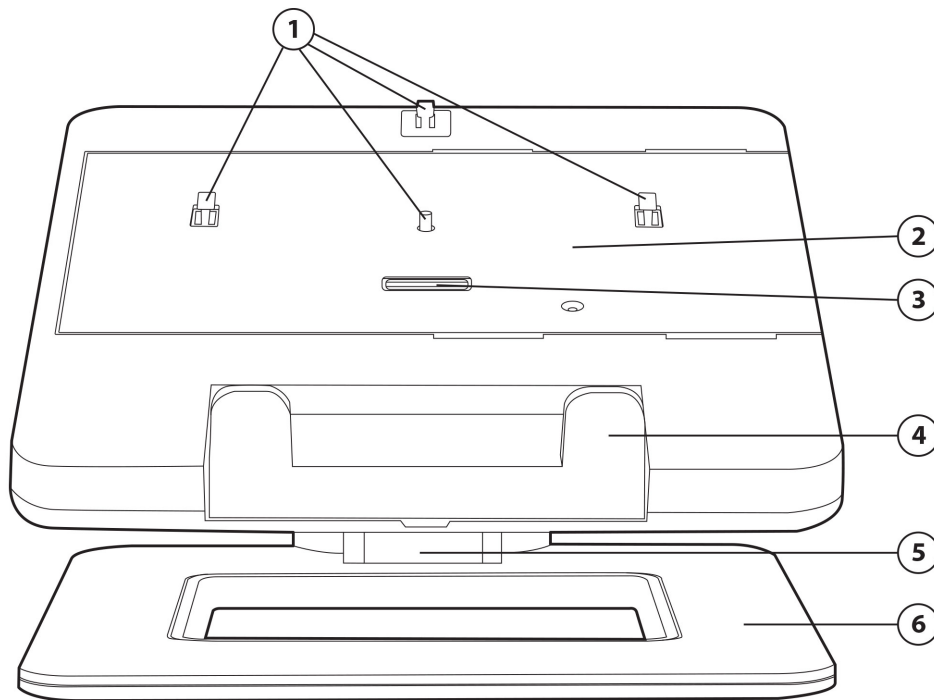

- | | |
|-------------------------|---------------------|
| 1. Docking posts | 4. Adjustable shelf |
| 2. Convertible platform | 5. Dual-hinged |
| 3. Eject button | 6. Base |

Overview

Dimensions (H x W x D)	8.7 x 11.8 x 14.2 in (22.0 x 30.0 x 36.0 cm)
Product weight	7.9 lbs. (3.6 kg)
Weight capacity	3.7-13.6 lbs. (1.7-6.2 kg) Notebook or notebook and docking station
Notebooks supported	12-17.3 in
Docks supported	HP 90W/230W Docking Stations, 120w/230W Advanced Docking Stations, UltraSlim Docks, 2570p Docking Station
Dual-hinged display stand	The dual-hinged, smooth-motion display stand allows for greater distance, height, and tilt adjustment for maximum comfort.
Docking posts	Aligns and secures the docking station to the stand and helps secure a connected docking station.
Removable convertible platform	Three-way convertible platform allows user to switch between HP 90W/230W Docking Stations, 120w/230W Advanced Docking Stations, UltraSlim Docks, 2570p Docking Station or no dock configuration
Cable management channels	Organizes and hides accessory cables in a central location to help reduce clutter when connecting multiple devices.
Service and support	One-year limited warranty. Additional support is available 24 hours a day, seven days a week by phone as well as online support forums. NOTE: Certain restrictions and exclusions apply. Consult the HP Customer Support Center for details.
Kit contents	HP Dual Hinge II Notebook Stand and documentation. Ships fully assembled in the Basic/Advanced Dock configuration

HP Dual Hinge Notebook Stand (AW661AA)

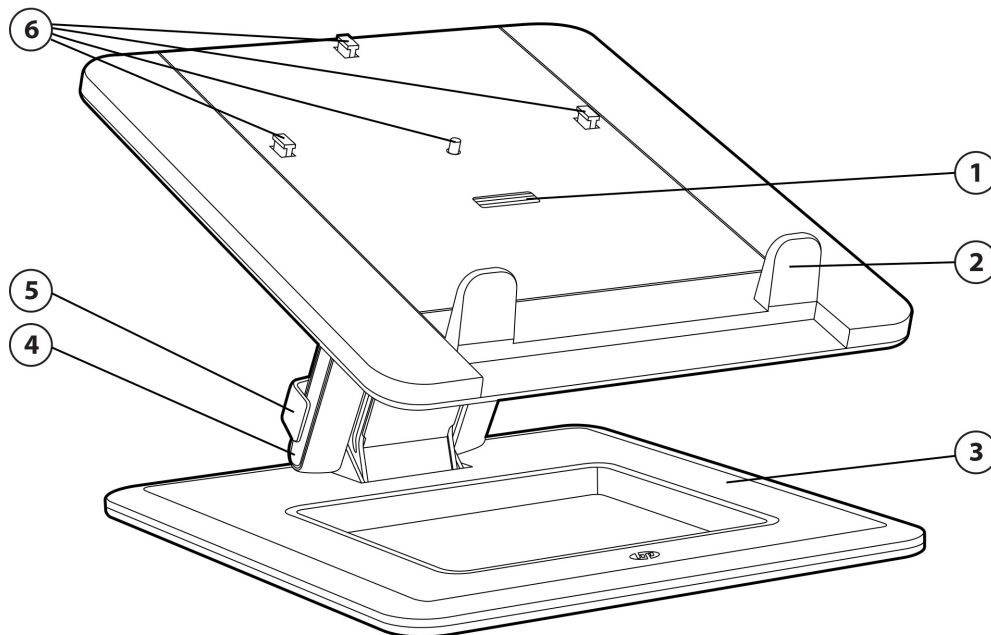

1. Eject button
2. Adjustable shelf
3. Removable convertible platform
4. Dual-hinged
5. Cable management channel
6. Docking posts

Overview

3. Base

6. Docking posts

Dimensions (H x W x D)

8.7 x 11.8 x 14.2 in (22.0 x 30.0 x 36.0 cm)

Product weight

7.9 lbs. (3.6 kg)

Weight capacity

3.7-13.6 lbs. (1.7-6.2 kg) Notebook or notebook and docking station

Notebooks supported

12-17.3 in

Docks supported

HP 90W/230W Docking Stations, 120w/230W Advanced Docking Stations, 2570p Docking Station.

Dual-hinged display stand

The dual-hinged, smooth-motion display stand allows for greater distance, height, and tilt adjustment for maximum comfort.

Docking posts

Aligns and secures the docking station to the stand and helps secure a connected docking station.

Adjustable shelf

Adjusts for different-sized notebook PCs.

Cable management channels

Organizes and hides accessory cables in a central location to help reduce clutter when connecting multiple devices.

Service and support

One-year limited warranty. Additional support is available 24 hours a day, seven days a week by phone as well as online support forums.

NOTE: Certain restrictions and exclusions apply. Consult the [HP Customer Support Center](#) for details.

Kit contents

HP Dual Hinge Notebook Stand and documentation.
Ships fully assembled

HP Adjustable Display Stand (AW663AA)

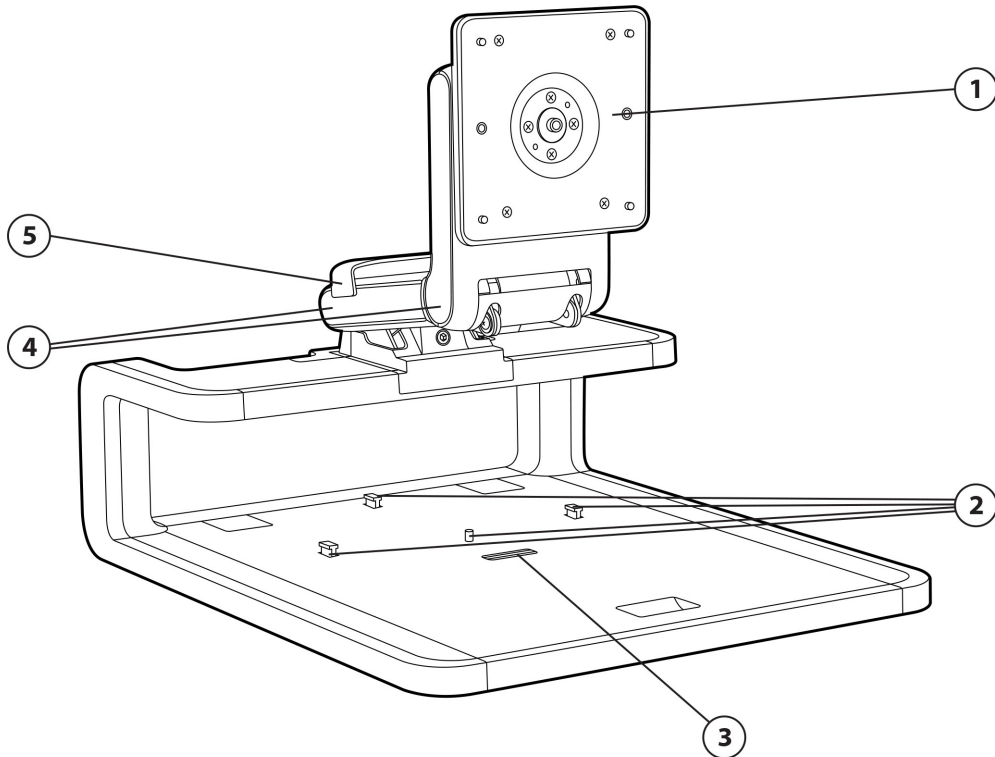

1. VESA display mount
2. Docking posts

4. Dual-hinged
5. Cable management channel

Overview

3. Eject button

	Rev B	Rev A
Dimensions (H x W x D)	16.9 x 13.8 x 15.7 in (43.0 x 35.0 x 40.0 cm)	16.9 x 13.8 x 15.7 in (43.0 x 35.0 x 40.0 cm)
Product weight	8.4 lbs. (3.8 kg)	8.4 lbs. (3.8 kg)
Maximum monitor weight	5.0-13.2 lbs. (2.3-6.0 Kg)	7.28-14.3 lbs. (3.3-7.0 kg)
Compatible displays	HP LCD display up to 24" with 100mm or 75mm VESA mounting pattern	HP LCD display up to 24" with 100mm VESA mounting pattern
Notebook supported	12-17.3 in	
Docks supported	HP 90W/230W Docking Stations, 120w/230W Advanced Docking Stations, UltraSlim Docks, 2570p Docking Station.	
Dual-hinged display stand	The dual-hinged, smooth-motion display stand allows for greater distance, height, and tilt adjustment for maximum comfort.	
Docking posts	Aligns and secures the docking station to the stand and helps secure a connected docking station.	
Cable management channels	Organizes and hides accessory cables in a central location to help reduce clutter when connecting multiple devices.	
Service and support	One-year limited warranty. Additional support is available 24 hours a day, seven days a week by phone as well as online support forums. NOTE: Certain restrictions and exclusions apply. Consult the HP Customer Support Center for details.	
Kit contents	Stand, riser, monitor bracket, hardware, kit and documentation	

HP LCD Monitor Stand (QM196AA)

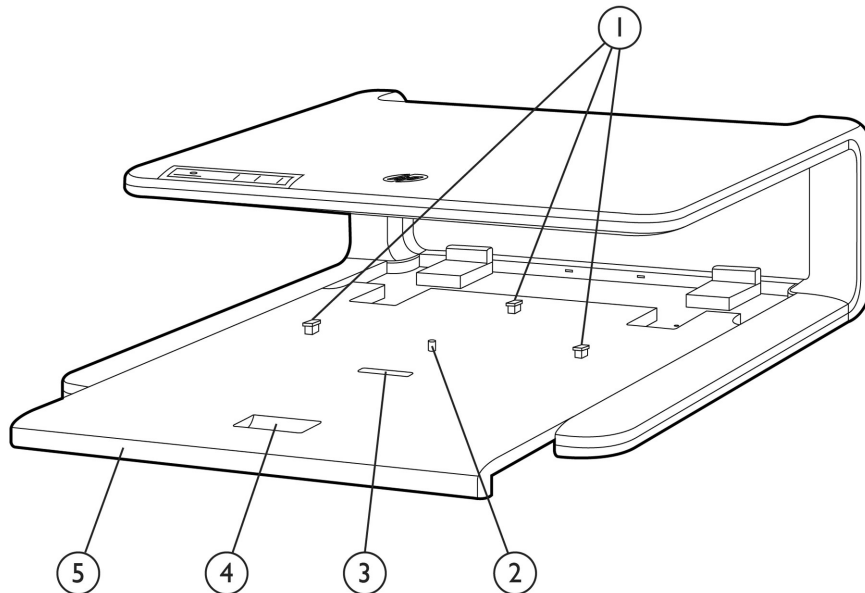

1. Docking posts
2. Docking release post
3. Eject button

4. Sliding tray button
5. Sliding tray

Overview

Dimensions (H x W x D)	Upper platform : 13.8" W x 10.8" D (35.0 x 27.5 cm) Notebook platform: 16" D x 5" H x 13.8" W (40.7 x 12.7 x 35.1 cm)
Product weight	6.8 lbs. (3.1 kg)
Monitor supported	LCD Display with base are not exceeding 12.4" W x 9.8" D (3.15 x 25.0 cm), not weighting more than 25 lbs. (11.3kg)
Notebooks supported	12-17.3 in
Docks supported	HP 90W/230W Docking Stations, 120w/230W Advanced Docking Stations, UltraSlim Docks, 2570p Docking Station.
Power button	Turns on power to the system. The light is turned on when the docked computer is turned on.
AC power light	Lights up when the docking station is connected to the AC power.
Dock light	Lights up when the computer is successfully docked to the docking station.
MultiBay II activity light	Indicates MultiBay II drive activity (on Advanced Docking Station only).
Docking posts	Aligns and secures the docking station to the stand.
Docking release post	Secures a connected docking station.
Release button	Releases the docking station from the stand.
Tray slide button	Adjusts the position of the docking station and notebook PC.
Docking station cable	Connects the docking station so you can use the monitor stand power button and activity light.
Service and support	One-year limited warranty. Additional support is available 24 hours a day, seven days a week by phone as well as online support forums. NOTE: Certain restrictions and exclusions apply. Consult the HP Customer Support Center for details. Power button - (not supported on UltraSlim Docks) AC power light - add at the end (not supported on UltraSlim Docks) Dock light - add at the end (not supported on UltraSlim Docks) Docking Station cable (not supported on UltraSlim Docks)
Kit contents	HP LCD Monitor Stand and documentation

HP Single Monitor Arm (BT861AA)

Dimensions (H x W x D)	N/A
Product weight	7.91 lbs. (3.59 kg)
Maximum monitor weight	7-20 lbs. (3.1-9.1 kg)
Compatible displays	HP LCD display up to 24" with 100mm or 75mm VESA mounting pattern
Kit contents	Arm, extension, desk clamp and grommet mount bases

© Copyright 2013 Hewlett-Packard Development Company, L.P. The information contained herein is subject to change without notice. The only warranties for HP products and services are set forth in the express warranty statements accompanying such products and services. Nothing herein should be construed as constituting an additional warranty. HP shall not be liable for technical or editorial errors or omissions contained herein.

September 2013