

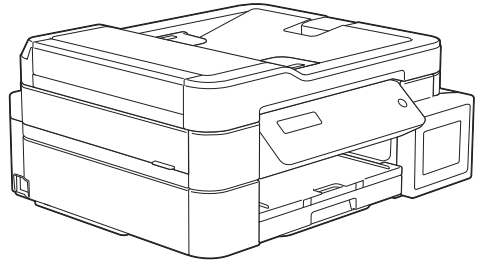

Reference Guide

Brief explanations for routine operations

DCP-T310
DCP-T510W
DCP-T710W



Brother recommends keeping this guide next to your Brother machine for quick reference.



Online User's Guide

For more advanced instructions, information, and product specifications, see the *Online User's Guide* at support.brother.com/manuals



User's Guides and Where to Find Them

Which Guide?	What's in It?	Where Is It?
Product Safety Guide	Read this Guide first. Please read the Safety Instructions before you set up your machine. See this Guide for trademarks and legal limitations.	Printed / In the box
Quick Setup Guide	Follow the instructions for setting up your machine, and installing the drivers and software for the operating system and connection type you are using.	Printed / In the box
Reference Guide	Learn the basic PC-Print, Scan and Copy operations and basic machine maintenance. See troubleshooting tips.	Printed or on Brother Installation Disc / In the Box
Online User's Guide	This guide includes the additional contents of the <i>Reference Guide</i> . In addition to information about the PC-Print, Scan, Copy, Internet services, Mobile Functions and Brother ControlCenter operations, useful information is included about using the machine on a network. ¹	Brother Solutions Center ²

¹ Network features are not available for some models.

² Visit support.brother.com/manuals.

For the Latest Driver Updates

Go to your model's **Downloads** page on the Brother Solutions Center at support.brother.com to download drivers. To keep your machine's performance up-to-date, check there for the latest firmware upgrades.

©2017 Brother Industries, Ltd. All rights reserved.

Questions or Problems? Take a Look at our FAQs, Solutions, and Videos Online.

Go to your model's **FAQs & Troubleshooting** page on the Brother Solutions Center at support.brother.com

- Provides several ways to search
- Displays related questions for more information
- Receives regular updates based on customer feedback

Control Panel Overview

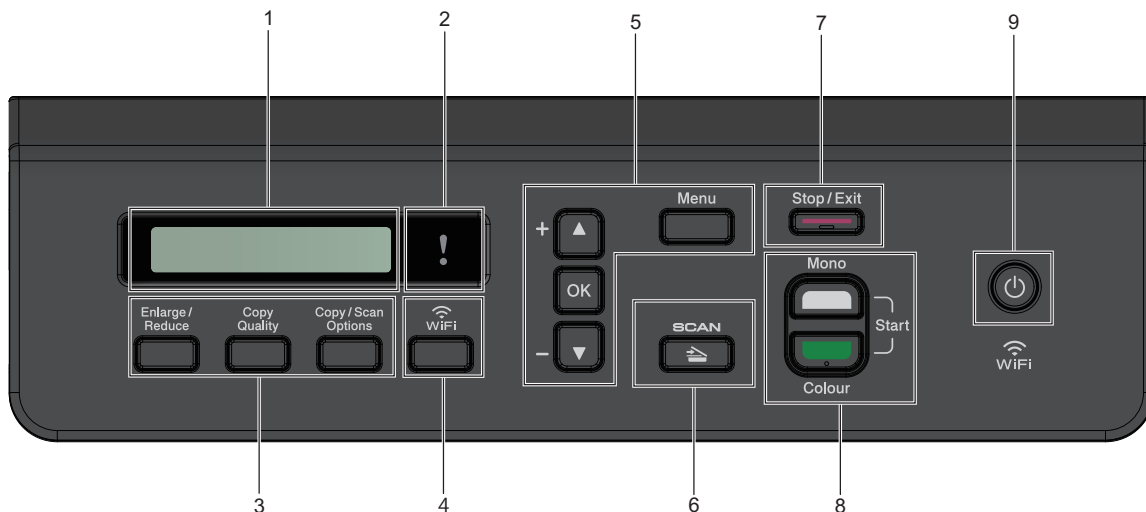

1. Liquid Crystal Display (LCD)

Displays messages to help you set up and use the machine.

2.  Warning LED

Blinks in orange when the LCD displays an error or an important status message.

3. Copy buttons

(DCP-T310)

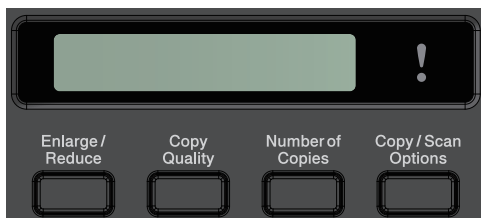

(DCP-T510W/DCP-T710W)

• **Enlarge / Reduce**

Press to enlarge or reduce copies.

• **Copy Quality**

Press to temporarily change the quality of your copies.

• **Number of Copies (DCP-T310)**

Press to make multiple copies.

• **Copy / Scan Options**

Press to access temporary settings for copying or scanning.

4. **WiFi (DCP-T510W/DCP-T710W)**

Press to configure the wireless settings while the machine is idle.

5. **Menu buttons****Menu**

Press to access the main menu.

▲ or ▼

Press to scroll through the menus and options.

OK

Press to select a setting.

6.  **SCAN**

Press to switch the machine to Scan mode.

7.  **Stop/Exit**

- Press to stop an operation.
- Press to exit from a menu.

8. **Start buttons**

 **Mono Start**

- Press to start making copies in monochrome.
- Press to start scanning documents (in colour or monochrome depending on the scan setting).

 **Colour Start**

- Press to start making copies in full colour.
- Press to start scanning documents (in colour or monochrome depending on the scan setting).

9.  **Power On/Off**

Press  to turn the machine on.

Press and hold down  to turn the machine off. The LCD displays [Shutting Down] and stays on for a few seconds before turning itself off.

If you turn the machine off using , it will still clean the print head periodically to maintain print quality. To prolong print head life, provide better ink efficiency, and maintain print quality, keep your machine connected to a power source at all times.

Load Paper

1 Load the paper in the paper tray as follows.



Fan the stack of paper well.

The paper size determines the orientation when loading paper.

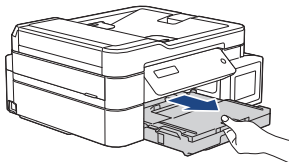
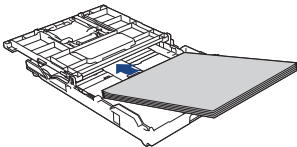
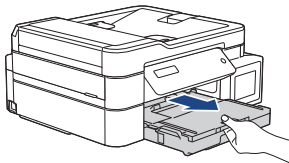
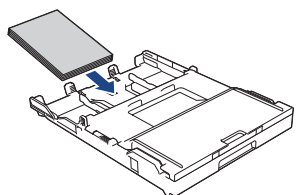
Tray #1	How to Load Paper	
A4/Letter Executive A5/A6 Photo 2L Index card Envelopes	 <p>Adjust the paper guides.</p>	 <p>Printing surface: Face down</p>
Photo	 <p>Adjust the paper guides.</p>	 <p>Printing surface: Face down</p>

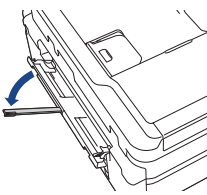
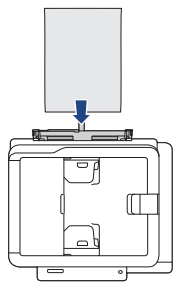
Manual Feed Slot ¹	How to Load Paper	
A4/Letter Executive A5/A6 Photo Photo L/2L Index card Envelopes	 <p>Adjust the paper guides.</p>	 <p>Printing surface: Face up</p>

¹ You can load only one sheet of paper into the manual feed slot at a time.

For more detailed information, see the *Online User's Guide: Load Paper*.

- 2** Unfold the paper support flap. Change the paper size setting in the machine's menu, if needed.

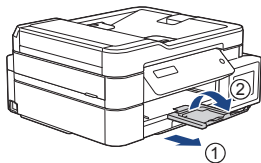

Load Documents

Place the document in the ADF or on the scanner glass as shown in the illustration.

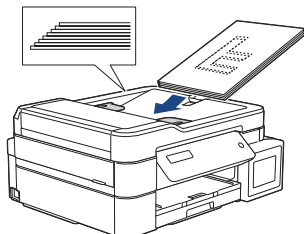
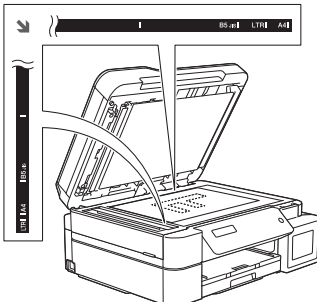
Automatic Document Feeder (ADF) (DCP-T710W)	Scanner Glass
 <p data-bbox="120 908 589 937">Place your document face down in the ADF.</p>	 <p data-bbox="692 975 1193 1033">Place the document face down in the upper left corner of the scanner glass.</p>

Print from Your Computer

Before attempting any printing operation, confirm the following:

- Make sure you have installed the Brother software and drivers.
- Make sure the USB cable is connected correctly, or that you are connected to the network using your wireless access point/router.

Print a Document (Windows®)

- 1 Select the print command in your application.
- 2 Select **Brother DCP-XXXX Printer** (where XXXX is the name of your model).
- 3 Click **Print**.
- 4 Complete your print operation.

Print a Document (Mac)

- 1 From an application, such as Apple TextEdit, click the **File** menu, and then select **Print**.
- 2 Select **Brother DCP-XXXX** (where XXXX is the name of your model).
- 3 Click **Print**.
- 4 Complete your print operation.

Various Printing

To use the various printing features, click the printing properties or preferences button to change the printer setting.

Print More Than One Page on a Single Sheet of Paper (N in 1)



For Windows®:

For more detailed information, see the *Online User's Guide: Print from Your Computer (Windows®)*.

For Mac:

For more detailed information, see the *Online User's Guide: Print from Your Computer (Mac)*.

Copy a Document

- 1 Make sure you have loaded the correct size paper in the paper tray.
- 2 Load your document.
- 3 Enter the number of copies in one of the following ways:
 - (DCP-T310) Press **Number of Copies** repeatedly.
 - (DCP-T510W/DCP-T710W) Press ▲ or ▼ on the control panel.
- 4 Change the copy settings, if needed.
 - a. Press **Options** or **Copy / Scan Options** on the control panel.
 - b. Press ▲ or ▼ to select the copy settings. When the setting you want appears, press **OK**.
- 5 When finished, press **Mono Start** or **Colour Start**.



To stop copying, press **Stop/Exit**.

Other Copy Options

You can use various copy features by changing copy settings. Press the **Options** or **Copy** buttons.

Enlarge or Reduce Copied Images

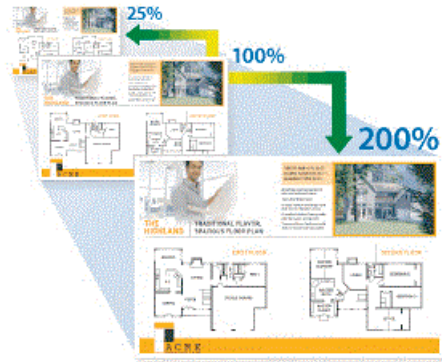

Layout Copies (N in 1 or Poster)



For more detailed information, see the *Online User's Guide: Copy*.

Before Scanning

Before attempting to scan, confirm the following:

- Make sure you have installed the Brother software and drivers.
- Make sure the USB cable is connected correctly, or that you are connected to the network using your wireless access point/router.

Scan from Your Computer

There are several ways you can use your computer to scan photos and documents on your Brother machine. Use the software applications provided by Brother, or use your favourite scanning application.

For more detailed information, see the *Online User's Guide: Scan from Your Computer (Windows®)* or *Scan from Your Computer (Mac)*.

Scan Using the Scan Button on the Machine

- 1 Load your document.
- 2 Press  (SCAN).
- 3 Press ▲ or ▼ to select the [Scan to PC] option, and then press **OK**.
- 4 Press ▲ or ▼ to select the [File] option, and then press **OK**.
- 5 If the machine is connected over the network, press ▲ or ▼ to select the

computer where you want to send data, and then press **OK**.



If the LCD prompts you to enter a PIN, use the control panel to enter the four-digit PIN for the computer, and then press **OK**.

- 6 Do one of the following:
 - To change the settings, press **Options** or **Copy / Scan Options**, and then go to the next step.
 - To use the default settings, press **Mono Start** or **Colour Start**.



- [Scan Type] depends on the default settings. Pressing **Mono Start** or **Colour Start** does not allow you to change the settings.
- To use scan options, a computer with either ControlCenter4 (Windows®) or Brother iPrint&Scan (Mac) software installed must be connected to the machine.

- 7 The machine will prompt you to set each of the following scan settings. Press ▲ or ▼ to select the desired option, and then press **OK** to proceed to the next scan setting.
 - [Scan Type]
 - [Resolution]
 - [File Type]
 - [Document Size]
 - [Remove Bkg Clr]
- 8 Press **Mono Start** or **Colour Start**.



[Scan Type] depends on the settings you have selected. Pressing **Mono Start** or **Colour Start** does not change the settings.

Check the Print Quality

If faded or streaked colours and text appear or if text is missing on your printouts, the print head nozzles may be clogged. Print the Print Quality Check Sheet and look at the nozzle check pattern.

- 1 Press **Menu**.
- 2 Press **▲** or **▼** to select the following:
 - a. Select [Maintenance]. Press **OK**.
 - b. Select [ImproveQuality]. Press **OK**.
 - c. Select [Check Quality]. Press **OK**.

- 3 Press **Colour Start**.
The machine prints the Print Quality Check Sheet.

- 4 Check the quality of the four colour blocks on the sheet.

- 5 The LCD asks about the print quality. Do one of the following:

- If all lines are clear and visible, press **▲** to select [Yes].

Press **Stop/Exit** to finish the Print Quality check.

- If lines are missing (see **Poor**, below), press **▼** to select [No].

OK (DCP-T310/DCP-T510W)

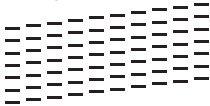

Poor (DCP-T310/DCP-T510W)

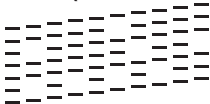

OK (DCP-T710W)

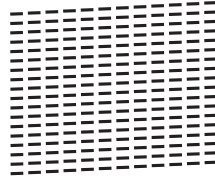

Poor (DCP-T710W)

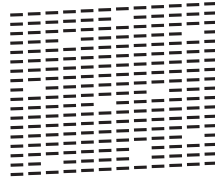

- 6 The LCD asks you to check the print quality of each colour. Press **▲** or **▼** to select one of the patterns that most closely matches the printing result, and then press **OK**.



Refer to the sample below to check the print quality.

Print Quality	DCP-T310/ DCP-T510W	DCP-T710W
None		
A Few		
About Half		
Many		

- 7** Do one of the following:
- If print head cleaning is needed, press **Colour Start** to start the cleaning procedure.
 - If print head cleaning is not needed, press **Stop/Exit** to finish the Print Quality check.

- 8** After the cleaning procedure is finished, press **▲**. Then, press **Colour Start**.
- The machine prints the Print Quality Check Sheet again. Check the quality of the four colour blocks on the sheet again.

If you clean the print head at least five times and the print has not improved, try cleaning the print head again up to three more times. If the print has not improved, contact Brother customer service or your local Brother dealer.

IMPORTANT

DO NOT touch the print head. Touching the print head may cause permanent damage and may void the print head's warranty.



When a print head nozzle is clogged, the printed sample looks like this.



After the print head nozzle is cleaned, the horizontal lines are gone.



For more detailed information, see the *Online User's Guide: If You Are Having Difficulty with Your Machine*.

Check the Print Alignment from Your Brother Machine

If your printed text becomes blurred or images become faded after transporting the machine, adjust the print alignment.

- 1** Press **Menu**.
- 2** Press **▲** or **▼** to select the following:
 - a. Select [Maintenance]. Press **OK**.
 - b. Select [ImproveQuality]. Press **OK**.
 - c. Select [Alignment]. Press **OK**.
- 3** Press **Mono Start** or **Colour Start**.

The machine starts printing the Alignment Check Sheet.

(A)

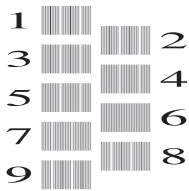

4 Select the number of the test print in one of the following ways:

- **DCP-T310/DCP-T510W/DCP-T710W**

For pattern (A), press ▲ or ▼ to select the number of the test print that has the fewest visible vertical stripes (1-9), and then press **OK**.

In the example above, row number 6 is the best choice.

Repeat this step for the rest of the patterns.



When the print alignment is not adjusted correctly, text looks blurry or crooked, like this.

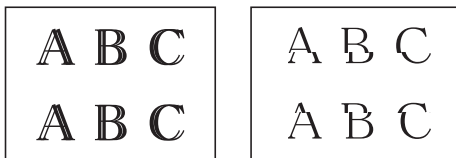

After the print alignment is adjusted correctly, text looks like this.



5 Press **Stop/Exit**.

Use this section to resolve problems you may encounter when using your Brother machine.

Identify the Problem

Even if there seems to be a problem with your machine, you can correct most problems yourself.

First, check the following:

- The machine's power cord is connected correctly and the machine's power is on.
- All of the machine's orange protective parts have been removed.
- The Scanner Cover and the Jam Clear Cover are fully closed.
- Paper is inserted correctly in the paper tray.
- The interface cables are securely connected to the machine and the computer, or the wireless connection is set up on both the machine and your computer.
- (For network models) The access point (for wireless), router, or hub is turned on and its link button is blinking.

To find the error and the solution, check the LCD or the machine's status in **Status Monitor** on your computer.

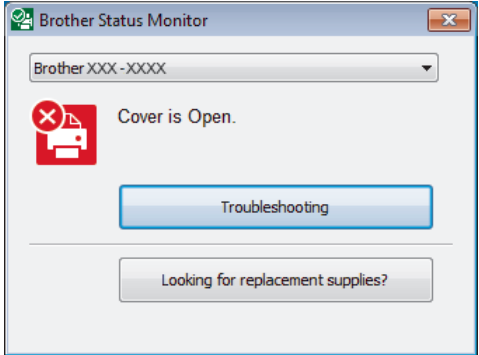
Using the LCD	Using the Status Monitor
<ol style="list-style-type: none"> 1. Follow the messages on the LCD. 2. See the instructions in the following Error and Maintenance Messages table. 3. If you cannot resolve the error, see the <i>Online User's Guide: Error and Maintenance Messages</i>. 	<ul style="list-style-type: none"> • Double-click the  icon in the task tray. • Each colour of the icon indicates the machine's status. • Click the Troubleshooting button to access Brother's troubleshooting website. 

Error and Maintenance Messages

The most common error and maintenance messages are shown in the table. For more detailed information, see the *Online User's Guide*.

You can correct most errors and perform routine maintenance yourself. If you need more tips, go to your model's **FAQs & Troubleshooting** page on the Brother Solutions Center at support.brother.com.

Error Message	Action
B&W Print Only Refill [X]	<p>The amount of remaining ink in one or more of the ink tanks (except black) is low.</p> <p>Refill the ink tank.</p> <p>For more detailed information, see the <i>Online User's Guide: Refill the Ink Tanks</i>.</p> <p>The machine may stop all print operations and you may not be able to use the machine until you refill the ink tank in the following cases:</p> <ul style="list-style-type: none"> • If you unplug the machine. • If you select the Slow Drying Paper option on the machine or in the printer driver.
Cannot Print Refill [X]	<p>The amount of remaining ink in one or more of the ink tanks is low. The machine will stop all print operations.</p> <p>Refill the ink tank.</p> <p>For more detailed information, see the <i>Online User's Guide: Refill the Ink Tanks</i>.</p> <ul style="list-style-type: none"> • You can still scan even if the ink is low or needs to be refilled.
Change Paper?	<p>This message is displayed when the setting to confirm the paper type and size is enabled.</p> <p>To not display this confirmation message, change the setting to Off.</p> <p>For more detailed information, see the <i>Online User's Guide: Change the Check Paper Size Setting</i>.</p>
Close ink cover.	<p>The ink tank cover is not locked in the closed position.</p> <p>Firmly close the ink tank cover until it locks into place.</p>
Data Remaining	<p>Press Stop/Exit. The machine will cancel the job and clear it from the memory. Try to print again.</p>
Document Jam	<p>The document was not inserted or fed correctly, or the document scanned from the ADF was too long.</p> <p>For more detailed information, see the <i>Online User's Guide: Document Jams</i>.</p>
High Temperature	<p>After cooling the room, allow the machine to cool down to room temperature. Try again when the machine has cooled down.</p>

Error Message	Action
Ink Low	<p>The amount of remaining ink in one or more of the ink tanks is low.</p> <p>Look through the window of the ink tank to confirm the actual amount of remaining ink.</p> <p>If the remaining ink level is at or below the lower line under the minimum fill mark, refill the ink tank.</p> <p>For more detailed information, see the <i>Online User's Guide: Refill the Ink Tanks</i>.</p> <ul style="list-style-type: none"> You can still scan even if the ink is low or needs to be refilled.
InkBox Full	<p>The ink absorber box must be replaced. Contact Brother customer service or your local Brother Authorised Service Centre to have your machine serviced.</p>
InkBox NearFull	<p>The ink absorber box must be replaced soon. Contact Brother customer service or your local Brother dealer.</p> <ul style="list-style-type: none"> The ink absorber box absorbs the small amount of ink emitted during print head cleaning.
Low Temperature	<p>After warming the room, allow the machine to warm up to room temperature. Try again when the machine has warmed up.</p>
No Paper Fed	<p>Do one of the following:</p> <ul style="list-style-type: none"> Refill the paper tray, and then press Mono Start or Colour Start. Remove and reload the paper, and then press Mono Start or Colour Start. <p>The paper was not inserted in the centre position of the manual feed slot.</p> <p>Remove the paper and reinsert it in the centre of the manual feed slot, and then follow the LCD instructions.</p> <p>For more detailed information, see the <i>Online User's Guide: Load Paper in the Manual Feed Slot</i>.</p> <p>The Jam Clear Cover is not closed correctly.</p>
Out of Memory	<p>If a copy operation is in progress:</p> <ul style="list-style-type: none"> Press Stop/Exit and wait until the other operations that are in progress finish, and then try again. Press Mono Start or Colour Start to copy the pages scanned so far.

Error Message	Action
Paper Jam	<p>Remove the jammed paper.</p> <p>For more detailed information, see the <i>Online User's Guide: Printer Jam or Paper Jam</i>.</p> <p>Make sure the paper guides are set to the correct paper size.</p> <p>Do not put more than one sheet of paper in the manual feed slot at any one time. Wait until the LCD prompts you to load another sheet of paper before you feed the next sheet of paper in the manual feed slot.</p> <p>Clean the paper pick-up rollers.</p> <p>For more detailed information, see the <i>Online User's Guide: Clean the Paper Pick-up Rollers</i>.</p>
Print Unable XX	<p>A foreign object, such as a paper clip or a piece of ripped paper, is in the machine.</p> <p>Open the scanner cover and remove any foreign objects and paper scraps from inside the machine.</p> <p>If the error message continues:</p> <ul style="list-style-type: none"> • Disconnect the machine from the power for several minutes, and then reconnect it.
Repetitive No Paper Fed	<p>Clean the paper pick-up rollers.</p> <p>For more detailed information, see the <i>Online User's Guide: Clean the Paper Pick-up Rollers</i>.</p>
Scan Unable XX	<ul style="list-style-type: none"> • Disconnect the machine from the power for several minutes, and then reconnect it.
Size Mismatch	<ol style="list-style-type: none"> 1. Check that the paper size you selected on the machine's display matches the size of the paper in the tray. For more detailed information, see the <i>Online User's Guide: Change the Paper Size and Paper Type</i>. 2. Make sure you loaded the paper in a Portrait position, by setting the paper guides at the indicators for your paper size. 3. After you have checked the paper size and the paper position, follow the LCD instructions. <p>If printing from your computer, make sure the paper size you selected in the printer driver matches the size of paper in the tray.</p> <p>For more detailed information, see the <i>Online User's Guide: Print Settings (Windows®) or Print Options (Mac)</i>.</p>
Tray not detected	<p>Slowly push the paper tray completely into the machine.</p> <p>Paper or a foreign object has prevented the paper tray from being inserted correctly.</p> <p>Pull the paper tray out of the machine, and remove the jammed paper or foreign object. If you cannot find or remove the jammed paper, see the <i>Online User's Guide: Printer Jam or Paper Jam</i>.</p>

Related Information

- Supply Specifications on page 19
-

Enter Text on Your Brother Machine

- The characters that are available may differ depending on your country.

You may need to enter text on your machine.

Entering numbers, letters and symbols

- Press ▲ or ▼ repeatedly to select the number, letter or symbol you want to choose, and press **OK** to enter that character. Repeat for each character until the number or name is complete and then press **OK**.

Inserting spaces

- To enter a space, press ▲ or ▼ repeatedly to select the space, and press **OK**.

Making corrections

- If you entered an incorrect number or letter and want to change it, press **Enlarge / Reduce**, **Number of Copies** (DCP-T310), or **Copy / Scan Options** several times to move the cursor under the incorrect character. Then press ▲ or ▼ repeatedly to re-enter the correct letter.

Information for compliance with Commission Regulation 801/2013

Models	Power consumption Networked Standby ¹
DCP-T310	Approx. 0.7 W
DCP-T510W/DCP-T710W	Approx. 1.0 W

¹ All network ports activated and connected

How to enable/disable Wireless LAN

- (DCP-T510W/DCP-T710W) To turn on or off the wireless network connection, press **Menu**, and then press ▲ or ▼ to select the following:
 1. Select [Network]. Press **OK**.
 2. Select [WLAN Enable]. Press **OK**.
 3. Select [On] or [Off]. Press **OK**.

Supply Specifications

Ink	The machine uses individual Black, Yellow, Cyan and Magenta ink tanks that are separate from the print head assembly.
Service Life of Ink Bottle	The first time you fill the tank the machine will use an amount of ink to fill the ink delivery tubes for high quality printouts. This process will only happen once. After this process is complete the ink bottles provided with your machine will have a lower yield than standard ink bottles (approximately 95% for Black and 90% for colour). With all following ink bottles you can print the specified number of pages.
Replacement Supplies	<p><Black Ink Bottle> BTD60BK</p> <p><Yellow Ink Bottle> BT5000Y</p> <p><Cyan Ink Bottle> BT5000C</p> <p><Magenta Ink Bottle> BT5000M</p> <p>Black - Approximately 6500 pages ¹</p> <p>Yellow, Cyan and Magenta - Approximately 5000 pages ¹</p>

¹ Quoted approx. yields are extrapolated based on Brother original methodology using Test Patterns ISO/IEC 24712.
Quoted approx. yields are not based on ISO/IEC 24711.



If using Windows[®], double-click the **Brother Creative Center** icon  on your desktop to access our **FREE** website designed as a resource to help you easily create and print customised materials for business and home use with photos, text and creativity.

Mac users can access Brother CreativeCenter at this web address:
www.brother.com/creativecenter

brother

Visit us on the World Wide Web
www.brother.com



CEE-ENG
Version B