

Nio 3MP LED Display

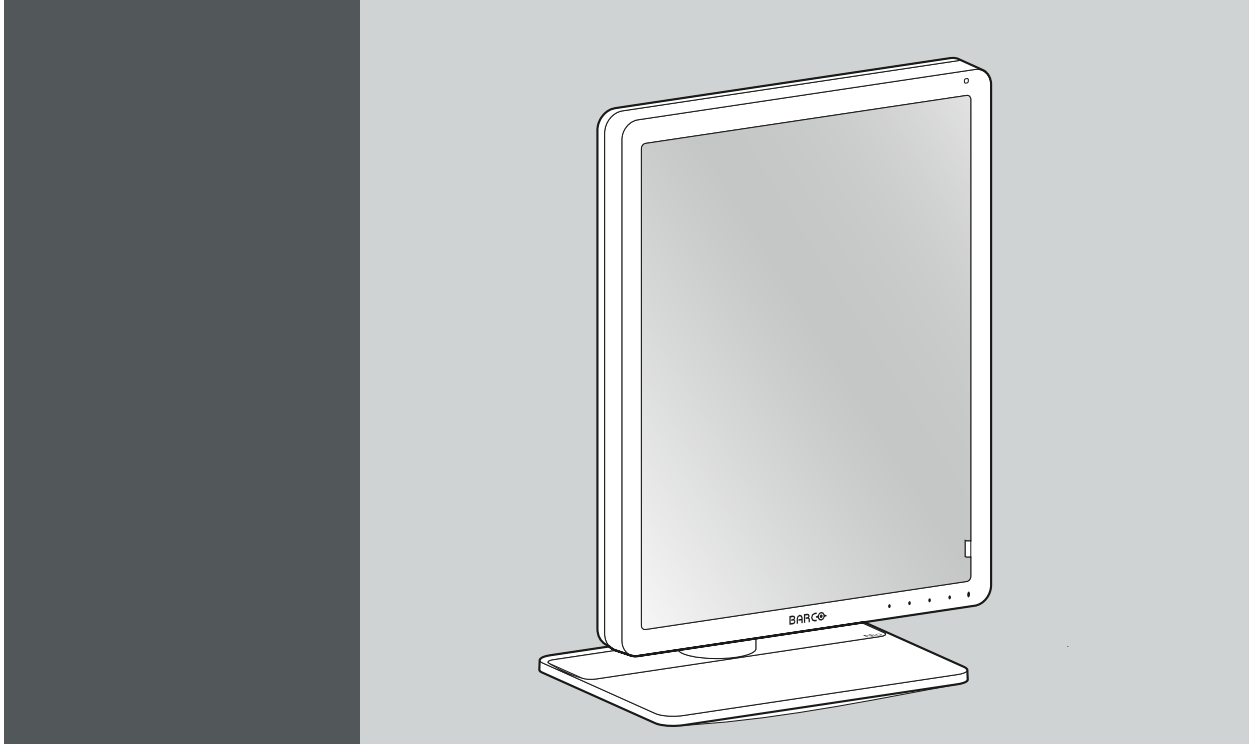

User Guide

MDNC-3421

Barco NV
President Kennedypark 35, 8500 Kortrijk, Belgium
Phone: +32 56.23.32.11
Fax: +32 56.26.22.62
Support: www.barco.com/en/support
Visit us at the web: www.barco.com

Printed in Belgium

TABLE OF CONTENTS

1. Welcome!	3
1.1 About the product	3
1.2 Symbols	3
1.3 What's in the box	4
2. Parts, controls and connectors	5
2.1 Display front view	5
2.2 Display rear view	6
3. Display installation	9
3.1 Unlocking the height mechanism	9
3.2 Adjusting the display position	9
3.3 Removing the connector compartment cover	10
3.4 Connecting the signal cables	11
3.5 Routing the cables & Reattach the connector compartment cover	12
3.6 VESA-mount installation	13
3.7 First time starting up	15
4. Daily operation	17
4.1 Recommendations for daily operation	17
4.2 Key indicator lights	18
4.3 Standby switching	18
4.4 Bringing up the OSD menus	19
4.5 Navigating through the OSD menus	19
5. Advanced operation	21
5.1 OSD menu language	21
5.2 OSD menu automatic close function	21
5.3 Power LED	21
5.4 Key indicator lights	22
5.5 Power lock function	22
5.6 DPMS mode	22
5.7 Hibernate	23
5.8 Luminance target	23
5.9 Viewing modes	24
5.10 Display functions	24
5.11 Color presets	25
5.12 Ambient Light Compensation (ALC)	26
5.13 Reading rooms	26
5.14 Embedded QA	27
5.14.1 About Embedded QA	27
5.14.2 DICOM status report	27
5.14.3 DICOM compliance check	28
5.14.4 DICOM calibration	28
5.14.5 Reset DICOM calibration	28
5.14.6 DICOM error threshold	29
5.15 Display orientation	29
5.16 Video input signals	29
5.17 EDID timings	30
5.18 EDID format	30
5.19 Display info	30
5.20 Display status	31
6. Repacking your display	33
6.1 Repackaging instructions	34
7. Cleaning your display	35
7.1 Cleaning instructions	35

8. Important information	37
8.1 Safety information.....	37
8.2 Environmental information	38
8.3 Regulatory compliance information	40
8.4 EMC notice	41
8.5 Explanation of symbols.....	44
8.6 Legal disclaimer.....	47
8.7 Technical specifications	47
8.8 Open source license information	49

1. WELCOME!

1.1 About the product

Overview

Thank you for choosing this Nio 3MP LED Display!

Nio 3MP LED Display is an industry-standard 3MP color display system with LED backlights for dependable diagnostic viewing in high-bright color. Nio 3MP LED Display provides an effective display solution for a multitude of applications and modalities, including 3D PACS, 3D echo, ultrasound, orthopedic imaging, CAD, image fusion, nuclear medicine and PET.

Confident color reading

Equipped with high-bright LED backlights, Nio 3MP LED Display delivers excellent brightness and more shades of gray to detect subtle details more quickly. The unique front sensor ensures you see consistent and precise images at all times for confident diagnoses.

On-demand image quality checks

As the front sensor works seamlessly together with Barco's online MediCal QAWeb service for automated Quality Assurance and calibration, Nio 3MP LED Display makes sure you are viewing perfect DICOM images — at the click of a button — without interrupting your workflow.

A good investment

Using power-efficient LED backlights, Nio 3MP LED Display is as low in power consumption as it is high in brightness. Because it uses less power, the display produces less heat and requires less cooling, which impacts maintenance and operational costs. Additionally, the LED backlights offer a long lifetime — even at high brightness — providing a high return on your investment.







CAUTION: Read all the important safety information before installing and operating your Nio 3MP LED Display. Please refer to the dedicated chapter in this user guide.

1.2 Symbols

Symbols in this document

The following symbols are used in this document:

	Caution: describes hazards that could damage the product.
	Warning: describes hazards or dangers that might result in personal injury or death.
	Note: gives extra information about the described subject
	Tip: gives extra advice about the described subject

1.3 What's in the box

Overview

Your Nio 3MP LED Display comes with:

- the display
- a system tilt and swivel foot
- this Nio 3MP LED Display user guide
- a system CD
- a video signal cable
- an USB cable
- an AC power cord
- an external power supply

If you ordered a Barco display controller, it's also in the box together with its accessories. A dedicated user guide is available on the system CD.



Keep your original packaging. It is designed for this display and is the ideal protection during transport and storage.

2. PARTS, CONTROLS AND CONNECTORS

2.1 Display front view

Overview

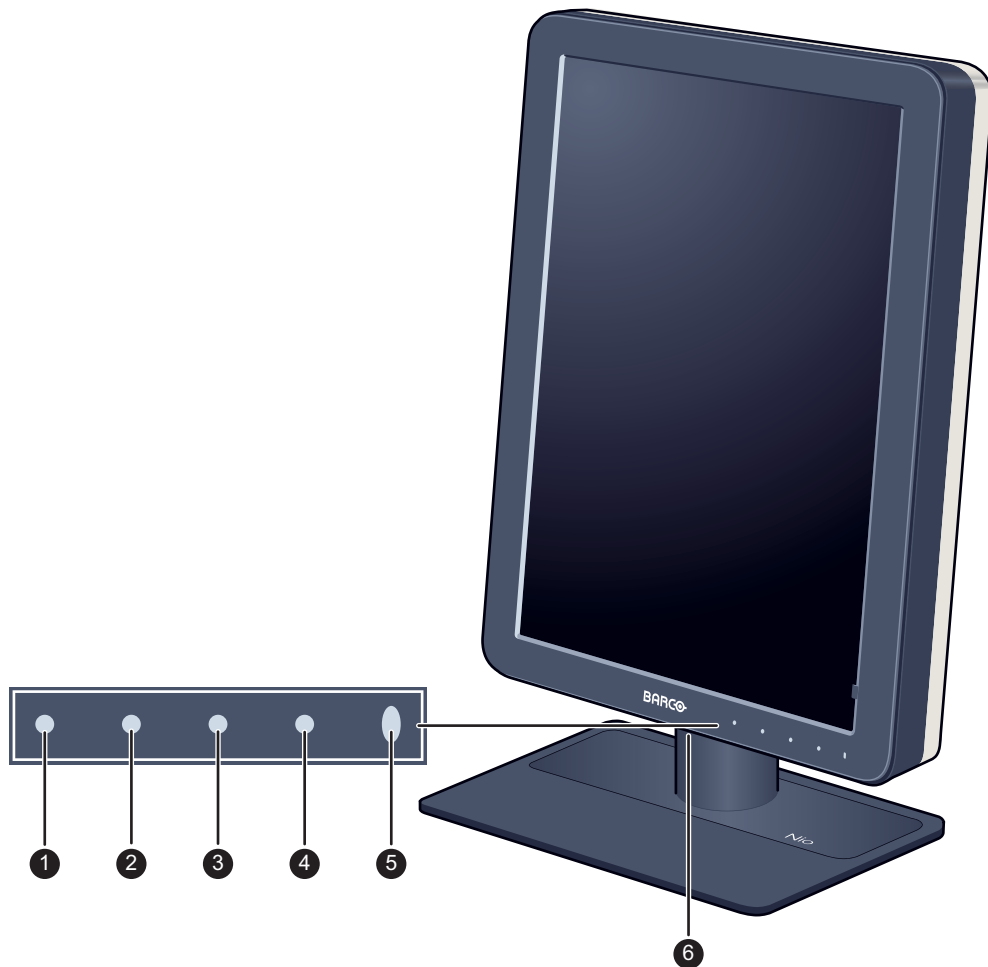

Image 2-1
Front view

- | | | | |
|---|-----------|---|-----------------------|
| 1 | Left key | 4 | Standby key |
| 2 | Right key | 5 | Power LEDs |
| 3 | Menu key | 6 | Bottom downstream USB |



The key icons are displayed above the keys, adapted to the function that it is used for (menu dependent). See "Navigating through the OSD menus", page 19.

2.2 Display rear view

Connector compartment cover closed

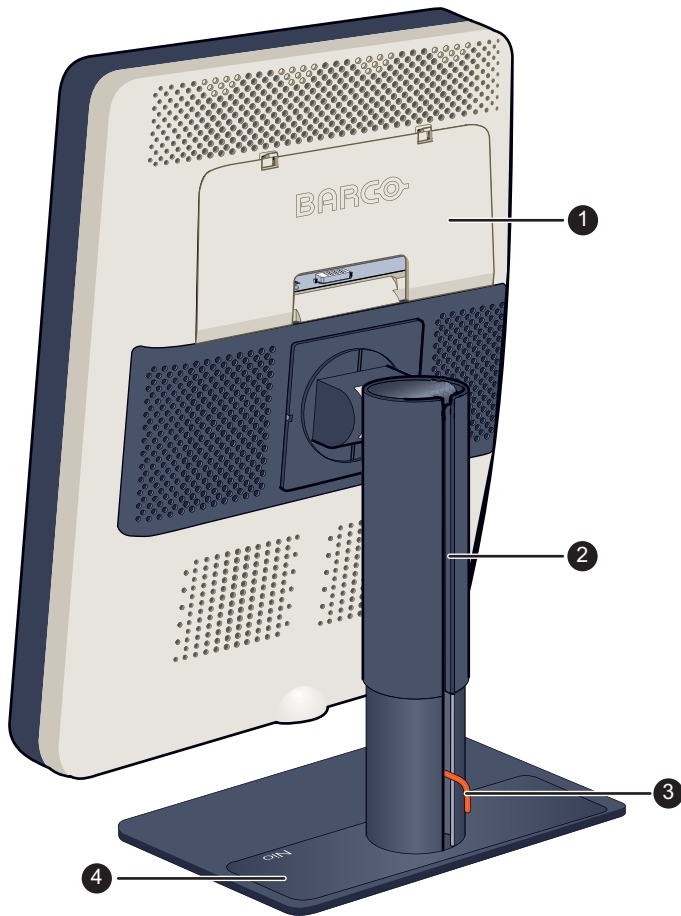

Image 2-2

- 1 Connector compartment cover
- 2 Cable duct
- 3 Foot lock clip
- 4 Tilt & swivel foot

Connector compartment cover open

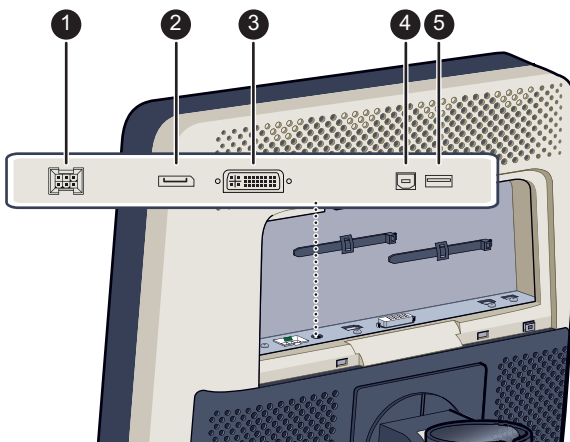

Image 2-3
Rear view with open connector compartment cover.

- ① +24 VDC power input
- ② DisplayPort video input
- ③ DVI video input
- ④ USB upstream connector
- ⑤ USB downstream connector

2. Parts, controls and connectors

3. DISPLAY INSTALLATION



Prior to installing your Nio 3MP LED Display and connecting all necessary cables, make sure to have a suitable display controller physically installed in your computer. If you are using a Barco display controller, please consult the user guide delivered with it to do this.

For a list of compatible display controllers, please refer to the latest version of the compatibility matrix available on my.barco.com (MyBarco > My Support > Healthcare > Compatibility Matrices > Barco Systems Compatibility Matrices).

3.1 Unlocking the height mechanism

To remove the clip:

1. Position the display with its rear side facing you.
2. Pull the red clip out of the fixation hole in the foot.

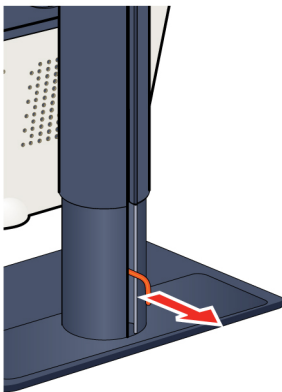

3. Keep the clip in the dedicated hole in case the display needs to be shipped later.

3.2 Adjusting the display position

To adjust the display position

1. Stand at the front side of the panel and take the panel at both sides.
2. Very important: Tilt the panel upwards before changing the orientation.

3. Display installation

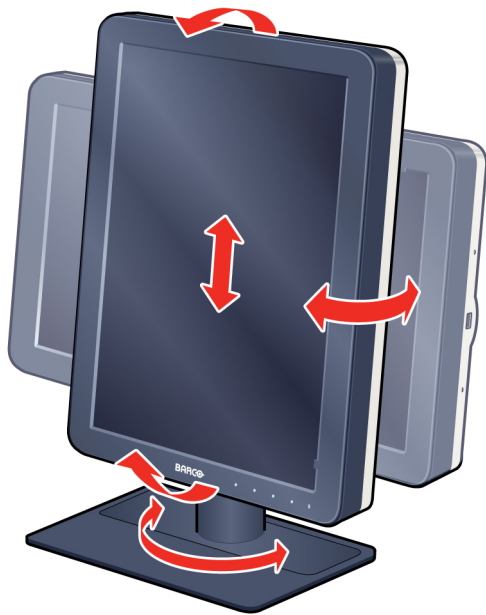

3. To change from portrait to landscape, turn the panel counterclockwise.
4. To change from landscape to portrait, turn clockwise.



If, after installing the display of the system, you change the panel orientation while an image is on the screen, the result depends on the graphic board and the resolution of the image. In some cases the image will be rotated automatically, in other cases it will not be rotated (e.g., when pixels would be lost after rotation). If necessary, change the image resolution in the display control panel and restart the system after changing the orientation.

3.3 Removing the connector compartment cover

To remove the connector compartment cover

1. Gently push the two lips on top of the cover
2. Pull the top of the cover slightly away from the display and lift the cover upwards.

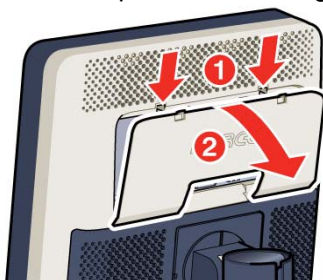

3.4 Connecting the signal cables



CAUTION: Only connect one of the two video links. Connecting both inputs simultaneously will result in driver errors.

To connect the signal cables to the display:

To get access to the connectors, remove the connector compartment cover. See "Removing the connector compartment cover", page 10.

You may connect the display to a display controller by using the DVI or the DP connection. The input selection of the device is automatically done. By default, the DisplayPort input has priority over the DVI input. This can be changed in the OSD menu.

1. Connect the DVI or DP of the display controller to the DVI or DP connector of the display.

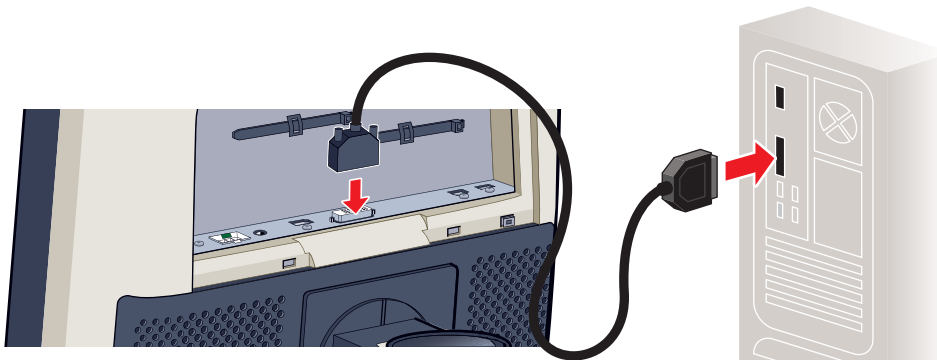

Image 3-1

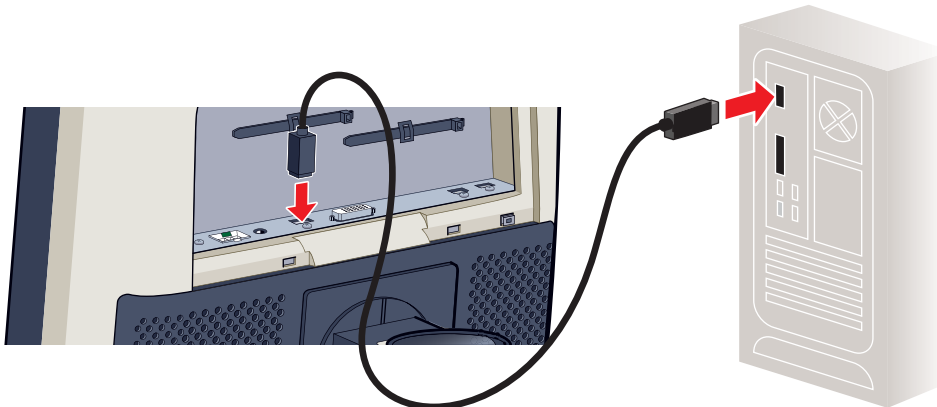

Image 3-2

3. Display installation

2. If you want to make use of the display's USB upstream connector, connect a PC USB downstream connector to the display's USB upstream connector.

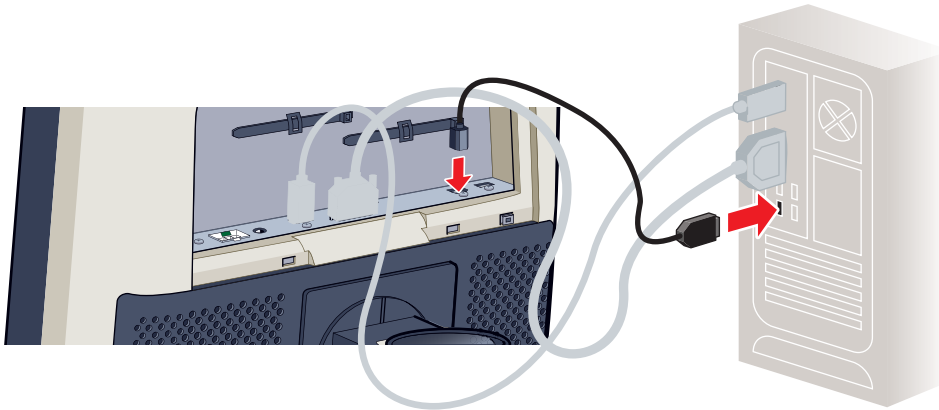

Image 3-3

3. If you have chosen to use the display's USB downstream connector, connect a USB device to the downstream connector.
4. Connect the supplied external DC power supply to the +24 Vdc power input of the display.
5. Plug the mains connector of the external DC power supply to a **grounded** power outlet by means of one of the supplied power cables.

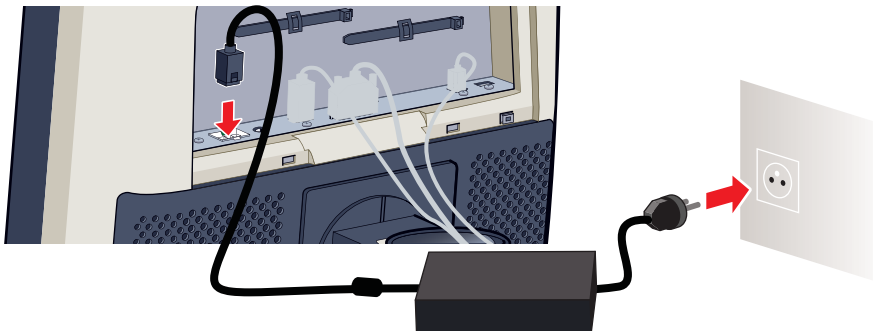
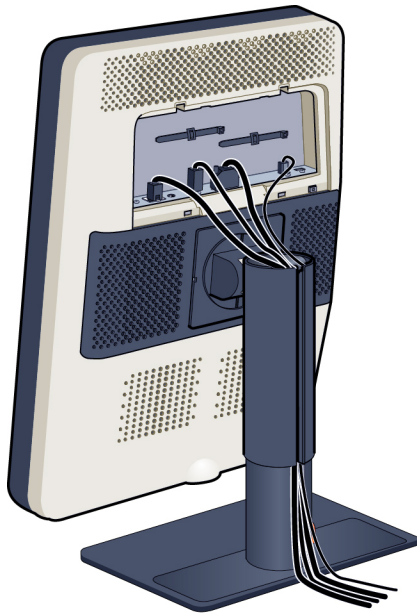

Image 3-4

3.5 Routing the cables & Reattach the connector compartment cover

To route the cables

1. Route all connected cables through the cable routing channel in the stand of your display.



Tip: The cable straps at the inside of the connector compartment allow you to fix the cables for better shielding of the cables.

To Reattach the connector compartment cover

1. Reattach the connector compartment cover by sliding the cover's bottom in position and then push the cover's top. You'll hear a "click" sound of the cover's clips when the connector compartment cover is in position.



3.6 VESA-mount installation



CAUTION: Use suitable mounting apparatus to avoid risk of injury.



WARNING: Never move a display attached to an arm by pulling or pushing the display itself. Instead, make sure that the arm is equipped with a VESA approved handle and use this to move the display.

Please refer to the instruction manual of the arm for more information and instructions.

3. Display installation



WARNING: Use an arm that is approved by VESA (according to the VESA 100 mm standard).

Use an arm that can support the weight of the display. Refer to the technical specifications of this display for the applicable weight.

Overview

The panel, standard attached to the tilt & swivel foot, is compatible with the VESA 100 mm standard. So it can be used with an arm stand according to the VESA 100 mm standard.

Therefore, the tilt & swivel foot must be removed from the panel.

1. Put the display in the lowest position and fasten the height mechanism, see "Unlocking the height mechanism", page 9 .

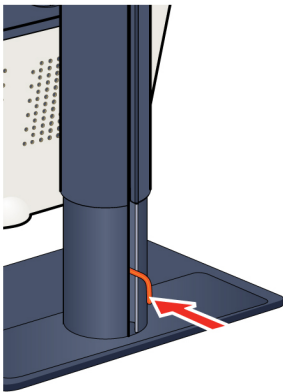

2. Put the display face down on a clean and soft surface. Be careful not to damage the panel screen.
3. Remove the plastic cover with a flathead screw driver.



- Slide the plastic cover over the neck of the foot.

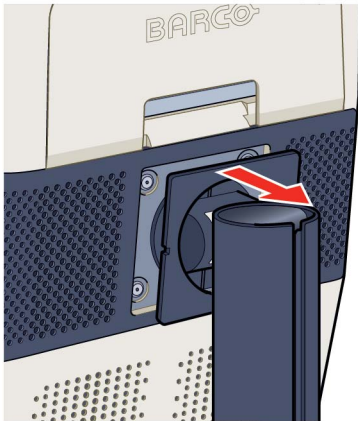

- Remove the four screws fixing the foot while supporting the foot.

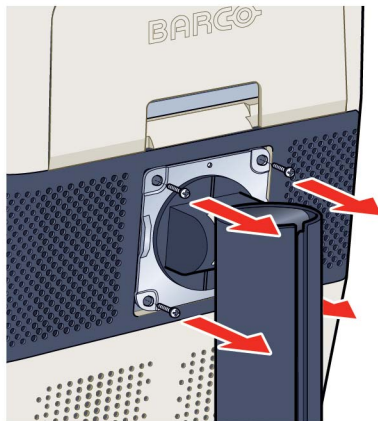

- Attach the arm stand **firmly** to the panel using 4 screws M4 x 8 mm.

3.7 First time starting up

Overview

You are now ready to start up your Nio 3MP LED Display for the first time.

- Switch on your Nio 3MP LED Display as described in "Standby switching", page 18.
- Turn on the computer connected to your display.

If you have properly installed your display and display controller, the Windows start-up messages will appear once the boot procedure is finished.



Your Nio 3MP LED Display will be running in a basic video mode at a default refresh rate when first time starting up. If you are using a Barco display controller, please consult the user guide delivered with it to install the drivers, software and documentation. When this is done, your display will automatically detect the connected video input signal(s) and apply the correct video mode and refresh rate.

3. *Display installation*

4. DAILY OPERATION

4.1 Recommendations for daily operation

Optimize the lifetime of your display

Enabling the Display Power Management System (DPMS) of your display will optimize its diagnostic lifetime by automatically switching off the backlight when the display is not used for a specified period of time. By default, DPMS is enabled on your display, but it also needs to be activated on your workstation. To do this, go to “Power Options Properties” in the “Control Panel”.



Barco recommends setting DPMS activation after 20 minutes of non-usage.

Use a screen saver to avoid image retention

Prolonged operation of an LCD with the same content on the same screen area may result in a form of image retention.

You can avoid or significantly reduce the occurrence of this phenomenon by using a screen saver. You can activate a screen saver in the “Display properties” window of your workstation.



Barco recommends setting screen saver activation after 5 minutes of non-usage. A good screen saver displays moving content.

In case you are working with the same image or an application with static image elements for several hours continuously (so that the screen saver is not activated), change the image content regularly to avoid image retention of the static elements.

Understand pixel technology

LCD displays use technology based on pixels. As a normal tolerance in the manufacturing of the LCD, a limited number of these pixels may remain either dark or permanently lit, without affecting the diagnostic performance of the product. To ensure optimal product quality, Barco applies strict selection criteria for its LCD panels.



To learn more about LCD technology and missing pixels, consult the dedicated white papers available at www.barco.com/healthcare.

Enhance user comfort

Every Barco multi-head display system is color matched with the highest specifications in the market.



Barco recommends keeping color-matched displays together. Furthermore, it is important to use all displays of a multi-head configuration at the same rate to preserve color matching throughout the economic lifetime of the system.

Maximize quality assurance

The 'MediCal QAWeb' system offers online service for high-grade Quality Assurance, providing maximum diagnostic confidence and uptime.



Barco recommends to install MediCal QAWeb Agent and apply the default QAWeb policy at least. This policy includes calibration on regular intervals. Connecting to MediCal QAWeb Server offers even more possibilities.

Learn more and sign up for the free MediCal QAWeb Essential level at www.barco.com/QAWeb.

4.2 Key indicator lights

About the key indicator lights

By default, the indicator lights of the keys will be dimmed which makes the keys unavailable at that moment. To make the keys illuminate and available for further actions touch one of the keys. As a result, all keys will be illuminated and are now available for further actions. However, if no further actions are taken within the following 5 seconds, the keys will dim again.



The key auto-dim function can be disabled in the OSD menus. Please refer to "Key indicator lights", page 22 for detailed instructions on how to do this.

4.3 Standby switching

About standby switching



The connected power supply also provides a switch that can be used to turn the power completely off. To use the display, please make sure to switch on this power supply. This can be done by pushing the on/off switch on the power supply into the " | " position.

Switching on the display while it is in standby mode or vice versa can be done by:

1. Illuminate the keys as previously described.
2. While the keys are illuminated, touch the standby key (right button) for approximately 2 seconds.

As a result, the display will switch on or will switch to standby mode.



In case of a power outage recovery, your display will always start-up in the power mode it was in before the power interruption (i.e. standby or on). This protects your display against inadvertent image retention problems.

4.4 Bringing up the OSD menus

How to bring up the OSD menus

The OSD menu allows you to configure different settings to make your Nio 3MP LED Display fit your needs within your working environment. Also, you can retrieve general information about your display and its current configuration settings through the OSD menu.

Bringing up the OSD menu can be done by:

1. If not already done so, switch on the display as previously described.
2. Illuminate the keys as previously described.
3. While the keys are illuminated, touch the menu key.

As a result, the OSD main menu comes up in the bottom right corner of the screen. However, if no further actions are taken within the following 90 seconds, the OSD will disappear again.



The OSD menu auto-exit function can be disabled in the OSD menu. Please refer to "OSD menu automatic close function", page 21 for detailed instructions on how to do this.

4.5 Navigating through the OSD menus

How to navigate through the OSD menus

Navigating through the OSD menu can be done by:

- Use the left/right keys to move through the (sub)menus, change values or make selections.
- To go into a submenu or confirm adjustments and selections, use the menu key.
- Use the standby key to cancel adjustments or exit a (sub)menu.
- Exit all OSD menus at once by touching the standby key for approximately 2 seconds.



The key icons are displayed above the keys, adapted to the function that it is used for (menu dependent).

Overview key icons



Left, Right



Menu



Enter

4. Daily operation



Cancel



Standby (IEC 60417-5009)

5. ADVANCED OPERATION

5.1 OSD menu language

About the OSD menu language

By default, the OSD menu comes up in English. However, there's a wide range of other languages available for the OSD menu of your Nio 3MP LED Display.

To change the language of the OSD menu:

1. Bring up the OSD main menu.
2. Navigate to the *Configuration > User Interface > Menu* menu.
3. Enter the *Language* submenu.
4. Select one of the available languages and confirm.

5.2 OSD menu automatic close function

About the OSD menu automatic close function

By default, the OSD menu will disappear automatically after approximately 90 seconds of inactivity. However, this function can be disabled so that the OSD menu remains on the screen until manually closed.

To enable/disable the OSD menu automatic close function:

1. Bring up the OSD main menu.
2. Navigate to the *Configuration > User Interface > Menu* menu.
3. Enter the *Automatic Close* submenu.
4. Select *Enabled/Disabled* as desired and confirm.

5.3 Power LED

About the power LED

To prevent distractions, the power LED is dimmed by default when the display is switched on and used in normal operation. This behavior can be changed so that the power LED will light up during normal operation. Below is an overview of the different power LED states, in ascending order of power consumption:

Display status	Power LED behavior
Off ¹	Dimmed
Hibernate ² / Soft off ³	Steady amber
Suspend mode ⁴	Slow blinking amber
Standby mode ⁴	Fast blinking amber
Normal operation	Dimmed (power LED disabled in OSD, default setting)
	Steady white (power LED enabled in OSD)

1. Power supply unplugged or switched off.
2. Requires DPMS mode and Hibernate to be enabled in the OSD menu.
3. Switched off via the standby touch key.
4. Requires DPMS mode to be enabled in the OSD menu.

To enable/disable the power LED:

1. Bring up the OSD main menu.
2. Navigate to the *Configuration > User Interface > Indicator Lights* menu.
3. Enter the *Power Status* submenu.
4. Select *Enabled/Disabled* as desired and confirm.

5.4 Key indicator lights

About the key indicator lights

By default, after lighting up, the key indicator lights will dim again if no further actions are taken within the following 5 seconds. However, this behavior can be changed so that the key indicator lights are always on or always off.

To configure the key indicator lights

1. Bring up the OSD main menu.
2. Navigate to the *Configuration > User Interface > Indicator Lights* menu.
3. Enter the *Keys* submenu.
4. Select *Automatic/Always On/Always Off* as desired and confirm.

5.5 Power lock function

About the power lock function

By enabling the power lock function, the Nio 3MP LED Display is forced to remain switched on. This means that it can't be switched to stand-by mode manually until the power lock function is disabled again.

To enable/disable the power lock function:

1. Bring up the OSD main menu.
2. Navigate to the *Configuration > User Interface > Controls* menu.
3. Enter the *Power Lock* submenu.
4. Select *Enabled/Disabled* as desired and confirm.

5.6 DPMS mode

About DPMS mode

Enabling the Display Power Management System (DPMS) mode on your display will optimize its diagnostic lifetime by automatically switching off the backlight when the display is not used for a specified period of time. By default, DPMS mode is enabled on your display, but it also needs to be activated on your workstation. To do this, go to the "Power options properties" window of your workstation.



Barco recommends setting DPMS activation after 20 minutes of non-usage.



When DPMS mode is enabled on your display, an additional OSD power saving function becomes available: hibernate. Please refer to "Hibernate", page 23 for more information on hibernation and how to enable this function.

To enable/disable DPMS mode on your display:

1. Bring up the OSD main menu.
2. Navigate to the *Configuration > Power Management* menu.
3. Enter the *DPMS Mode* submenu.
4. Select *Enabled/Disabled* as desired and confirm.

5.7 Hibernate

About hibernate

When hibernate is enabled, not only the backlight will be switched off, but also other functionalities will be disabled to further reduce power consumption to a minimum. This happens after a specific period of time which can be manually adjusted.



Hibernate can only be enabled on your display when the DPMS mode is enabled first. Therefore, please refer to "DPMS mode", page 22 to do this.



Please connect your keyboard or mouse to your PC rather than to the display USB ports when hibernate is enabled.

To enable/disable hibernation on your display:

1. Bring up the OSD main menu.
2. Navigate to the *Configuration > Power Management* menu.
3. Enter the *Hibernate* submenu.
4. Select *Enabled/Disabled* as desired and confirm.

To specify the hibernate timeout:

1. Bring up the OSD main menu.
2. Navigate to the *Configuration > Power Management* menu.
3. Enter the *Hibernate Timeout* submenu.
4. Set the timeout value as desired and confirm.

5.8 Luminance target

About the luminance target

The luminance target of your Nio 3MP LED Display is adjustable over a predefined range. When you change the luminance target, the display will adjust its backlight to reach the target.

To set the luminance target:

1. Bring up the OSD main menu.
2. Navigate to the *Configuration > Calibration* menu.
3. Enter the *Luminance Target* submenu.
4. Set a luminance target value as desired and confirm.



The default, factory DICOM calibrated luminance value is available in the technical specifications table. The guaranteed backlight lifetime is valid for this setting.

5.9 Viewing modes

About viewing modes

The Nio 3MP LED Display can be used in two viewing modes:

- **Diagnostic:** This mode provides the full calibrated luminance and is intended for using the display for diagnostic purposes.
- **Text:** In this mode, the luminance is reduced to approximately half of the luminance. This is intended for using the display with office applications such as word processing. Please note that text mode is not persistent, once powered off, the unit will restart in diagnostic mode.



To quickly switch the viewing mode without having to enter the OSD menu, touch the left and right key (the two leftmost buttons) at the same time during normal operation.



As the Nio 3MP LED Display is intended to be used in a diagnostic environment, the diagnostic mode should always be selected.

To select a viewing mode:

1. Bring up the OSD main menu.
2. Navigate to the *Configuration > Calibration* menu.
3. Enter the *Viewing Mode* submenu.
4. Select *Diagnostic/Text* as desired and confirm.

5.10 Display functions

About display functions

Native, uncorrected panels will display all grayscale/color levels with luminance increments that are not optimal for crucial diagnostic information. Studies have shown however, that in medical images certain grayscale/color parts contain more diagnostic information than others. To respond to these conclusions, display functions have been defined. These functions emphasize on these parts containing crucial diagnostic information by correcting the native panel behavior.

The available display functions for your Nio 3MP LED Display are:

- **Native:** If you select Native, the native panel behavior will not be corrected.
- **Dynamic Gamma 1.8 or 2.2:** These are gamma functions that are shifted to take into account the non-zero luminance of an LCD panel when driven with a “black” signal. They are especially useful in CT applications to improve the perception of low Hounsfield values.
- **DICOM:** DICOM (Digital Imaging and Communications in Medicine) is an international standard that was developed to improve the quality and communication of digital images in radiology. In short, the DICOM display function results in more visible grayscales in the images. Barco recommends selecting the DICOM display function for most medical viewing applications.
- **User:** This display function will be automatically selected when display functions are defined by MediCal QAWeb.
- **Gamma 1.8 or 2.2:** Select one of these display functions in case the display is to replace a CRT display with a gamma of 1.8 or 2.2 respectively.



The settings of the display must be adapted to suit the requirements of the visualization software. In case of doubt, please contact the vendor of the visualization software.

To select a display function:

1. Bring up the OSD main menu.
2. Navigate to the *Configuration > Calibration* menu.
3. Enter the *Display Function* submenu.
4. Select one of the available display functions and confirm.

5.11 Color presets

About color presets

The available color preset settings for your display are:

- **Clearbase:** Simulation of the clearbase film color temperature.
- **Bluebase:** Simulation of the bluebase film color temperature.
- **User:** When selecting the User color temperature setting, you will be able to manually define the X and Y coordinates or the display color temperature in separate submenus.
- **Native White:** The native, unmodified color temperature of the LCD panel.

To select a color preset:

1. Bring up the OSD main menu.
2. Navigate to the *Configuration > Calibration > Color Settings* menu.
3. Enter the *Color Presets* submenu.
4. Select one of the available Color Presets and confirm.

5.12 Ambient Light Compensation (ALC)

About ALC



Ambient Light Compensation (ALC) can only be enabled on your display when the DICOM display function is selected. Therefore, please refer to "Display functions", page 24 to correctly set the display function.

When ALC is enabled, the DICOM display function will be recalculated taking a preset ambient light correction value into account. This value is determined by the selected reading room. Therefore, it is also important to select a realistic reading room when enabling ALC. This can be done by following the instructions in "Reading rooms", page 26.

To enable/disable ALC:

1. Bring up the OSD main menu.
2. Navigate to the *Configuration > Calibration > Ambient Light* menu.
3. Enter the *Ambient Light Compensation* submenu.
4. Select *Enabled/Disabled* as desired and confirm.

5.13 Reading rooms

About reading rooms



Reading rooms can only be selected when the DICOM display function is selected. Therefore, please refer to "Display functions", page 24 to correctly set the display function.

The American Association of Physicists in Medicine (AAPM) composed a list of pre-defined reading rooms. Each of these reading rooms are defined by following parameters:

- the maximum light allowed in this type of room
- the preset ambient light correction value for this reading room

These parameters are stored in your display and determine the preset ambient light correction value to take into account to recalculate the DICOM display function when Ambient Light Compensation (ALC) is enabled. Please refer to "Ambient Light Compensation (ALC)", page 26 to enable ALC.

The available reading rooms for your Nio 3MP LED Display are:

- **CR/DR/ MAMMO:** Corresponds to light conditions in diagnostic reading rooms for computed radiology, digital radiology or mammography. This setting has the lowest maximum ambient light.
- **CT/MR/NM:** Corresponds to light conditions in diagnostic reading rooms for computed tomography, magnetic resonance or nuclear medicine scans.
- **Staff Office:** Corresponds to light conditions in office rooms.
- **Clinical Viewing Room:** Corresponds to light conditions in diagnostic reading rooms for clinical viewing.
- **Emergency Room:** Corresponds to light conditions in emergency rooms.
- **Operating Room:** Corresponds to light conditions in operating rooms. This setting has the highest maximum ambient light.

To select a reading room:

1. Bring up the OSD main menu.

2. Navigate to the *Configuration > Calibration > Ambient Light* menu.
3. Enter the *Reading Room* submenu.
4. Select one of the available reading rooms and confirm.

5.14 Embedded QA

Overview

- About Embedded QA
- DICOM status report
- DICOM compliance check
- DICOM calibration
- Reset DICOM calibration
- DICOM error threshold

5.14.1 About Embedded QA

About

Embedded QA allows you to run a display calibration or compliance test directly from the display using the OSD menus described in the next sections. Embedded QA will use the front sensor / I-Guard to measure the necessary luminance levels for either a calibration or compliance test. Various settings for both actions can be selected from the display's OSD menu. The last results of both actions can be consulted from the OSD.

Embedded QA or MediCal QAWeb?

Embedded QA is not a replacement for the Barco MediCal QAWeb solution.

Although Embedded QA is a reliable option to perform a simple calibration or compliance test, Barco still highly recommends MediCal QAWeb as the solution of choice for calibration and QA. Medical QAWeb brings many benefits such as centralized asset management, the ability to schedule tasks, remote management, automated reporting, alerting and specific support of regional QA standards such as DIN 6868-57, JESRA and AAPM TG18. That's why MediCal QAWeb Agent acts as the master for all supported displays from the moment it is installed and running. MediCal QAWeb Agent will take over from Embedded QA and overwrite any settings which were applied by Embedded QA.

5.14.2 DICOM status report

About DICOM status report

Following information is available:

DICOM Compliance Status (status since last compliance check):

- **Compliance status:** Shows if the current DICOM curve is compliant or not.
- **Maximum error:** Shows the maximum error of the current DICOM curve. This is the deviation compared to a perfect DICOM.
- **Error threshold:** Shows the error threshold. This is the maximum error allowed before a DICOM calibration is required.
- **Time elapsed since latest compliance check:** Shows the backlight runtime since last compliance check.
- **Display Function:** Shows the current display function.
- **Ambient light compensation:** Shows the ambient light compensation status.
- **Reading Room:** Shows the selected reading room.
- **Luminance:** Shows the measured luminance.

- **Black luminance:** Shows the measured backlight luminance.

DICOM Calibration Status:

- **No calibration executed yet:** No other information is visible
- **Calibration executed:** When the calibration is executed, the following extra information is shown: Backlight runtime elapsed since latest calibration, display function, ambient light compensation, reading room.

Current DICOM Settings

- **Display Function:** Shows the current display function.
- **Ambient Light Compensation:** Shows the ambient light compensation status.
- **Reading room:** Shows the selected reading room.

To retrieve the DICOM status report:

1. Bring up the OSD main menu.
2. Navigate to the *Configuration > Calibration > Embedded QA* menu.
3. Select *DICOM status report* to make the information visible on the screen.

5.14.3 DICOM compliance check

About DICOM compliance check

The DICOM compliance check will measure the DICOM curve of your display in different steps. After measurement, the DICOM status report is shown.

To start DICOM compliance check:

1. Bring up the OSD main menu.
2. Navigate to the *Configuration > Calibration > Embedded QA* menu.
3. Select *DICOM compliance check* to start the compliance check.
Warning: Pressing a key during the compliance check will abort the check.

5.14.4 DICOM calibration

About DICOM calibration

The DICOM calibration will add a correction to the current DICOM curve to approach the perfect DICOM curve as good as possible.

To start DICOM calibration:

1. Bring up the OSD main menu.
2. Navigate to the *Configuration > Calibration > Embedded QA* menu.
3. Select *DICOM calibration* to start the calibration.
Warning: Pressing a key during calibration will abort the calibration, previous values will be restored.
Note: After calibration, the compliance check will start automatically.

5.14.5 Reset DICOM calibration

About reset DICOM calibration

It is possible to restore the original (not corrected) DICOM curve.

To reset the DICOM calibration:

1. Bring up the OSD main menu.
2. Navigate to the *Configuration > Calibration > Embedded QA* menu.

3. Enter the *DICOM preferences* submenu.
4. Select *reset DICOM calibration* to restore the original (not corrected) DICOM curve.

5.14.6 DICOM error threshold

About DICOM error threshold

The threshold to define the DICOM compliance can be modified in steps of 5% starting from 5 to 30%. When the maximum deviation is not bigger than the selected threshold, the compliance check will be OK.

To set the DICOM error threshold:

1. Bring up the OSD main menu.
2. Navigate to the *Configuration > Calibration > Embedded QA* menu.
3. Enter the *DICOM preferences* submenu.
4. Set *DICOM error threshold* as desired and confirm.

5.15 Display orientation

About Display orientation

Your display automatically detects its physical orientation (portrait or landscape) and, by default, automatically adjusts the image orientation to this. This means that when your display is physically rotated, the image will rotate along.

The OSD menu however, allows to overrule this behavior and force the image orientation to portrait or landscape regardless of the physical orientation of the display. This may be especially useful when operating your display with the screen facing upwards.

To set the Display orientation

1. Bring up the OSD main menu.
2. Navigate to the *Configuration > Image Sources* menu.
3. Enter the *Display Orientation* submenu.
4. Select *Landscape/Portrait/Automatic* as desired and confirm.

5.16 Video input signals

About input signals

The available input signals for your display are:

- **DisplayPort:** The input corresponding to the DisplayPort connector.
- **DVI:** The input corresponding to the DVI connector.
- **Automatic Selection:** The input is automatically selected.

To manually select a video input signal:

1. Bring up the OSD main menu.
2. Navigate to the *Configuration > Image Source* menu.
3. Enter the *Image Source* submenu.
4. Select one of the available input signals and confirm.

5.17 EDID timings

About EDID timings

Following EDID timings are available for your Nio 3MP LED Display:

- **Refresh Rate:** Allows to manually select the refresh rate of the image source video input signal depending on the maximum refresh rate of the display controller connected to your display.
- **Color Depth:** Allows to change the color depth to 8 or to 10 bit.
Please note that the Color Depth setting is only available for the DisplayPort input.

To manually set EDID timings:

1. Bring up the OSD main menu.
2. Navigate to the *Configuration > Image Source > Input Settings > DisplayPort* or *DVI* menu.
3. Enter the *EDID* submenu.
4. Select *Refresh Rate* or *Color Depth*.
5. Select one of the available settings and confirm.

5.18 EDID format

About EDID format

Your Nio 3MP LED Display describes its capabilities to the display controller by means of display identification data. This data contains timings, display size, pixel mapping info, etc. and is needed to make sure that the video source can be correctly displayed.

Display identification data is structured in a standard VESA format. Depending on the configuration setup of your system, a different format can be used.

The Nio 3MP LED Display supports following EDID formats:

- **E-EDID V1.4:** E-EDID is a mature and more commonly used format. It is supported by most display controllers and operating systems.
- **DisplayID V1.3:** DisplayID is designed to replace E-EDID and supports more advanced communication between your Nio 3MP LED Display and its display controller. Since not all display controllers and operating systems support DisplayID already, it should only be selected if all components are DisplayID compatible.

To select the EDID format

1. Bring up the OSD main menu.
2. Navigate to the *Configuration > Image Source > Input Settings* menu.
3. Enter the *EDID format* submenu.
4. Select one of the available settings and confirm.

5.19 Display info

About display info

Your display serial number, color type, native resolution, firmware versions, etc. are available in a dedicated submenu of the OSD menu.

To retrieve info about your display:

1. Bring up the OSD main menu.
2. Navigate to the *About this Display* menu to make the information visible on the screen.

5.20 Display status

About display status

The Status submenu of the OSD menu provides info on the current status of your display (runtimes, temperatures, etc.), the status of the connected image sources (video encoding mode, timings, etc.), the current calibration status of your display (display function, luminance, ALC, etc.) and the status about activated connections.

To retrieve the status of your display:

1. Bring up the OSD main menu.
2. Navigate to the *Status* menu.
3. Enter the *Display*, *Image Sources* or *Calibration* submenu as desired.

6. REPACKING YOUR DISPLAY

Overview of the packaging

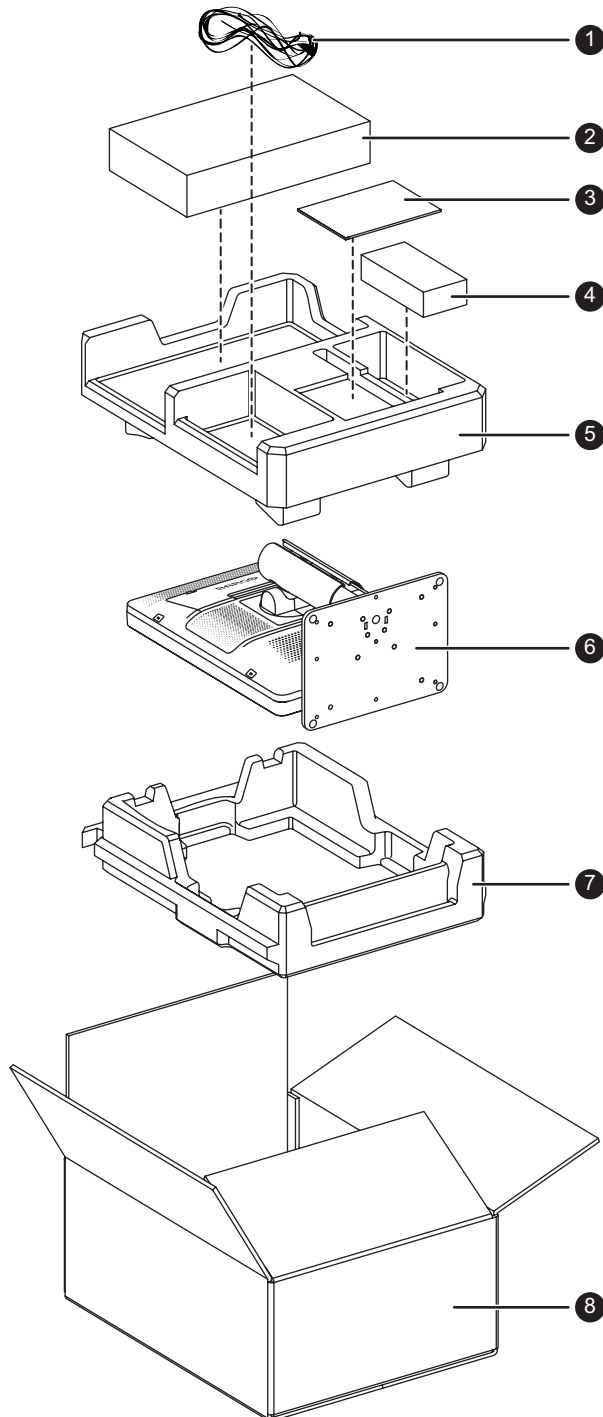

Image 6-1

6. Repacking your display

1. Video and power cables
2. Display controller box
3. System CD('s) and user guide
4. Power supply
5. Top buffer
6. Display
7. Bottom buffer
8. Box

6.1 Repackaging instructions

To repack your display

1. Place the empty box on a stable surface.
2. Place the bottom buffer in the box.
3. Put the display in its original bag and place it in the box with the panel facing downwards.
4. Put the top buffer on top of the display.
5. Put the power supply in the dedicated cavity of the top buffer.
6. Put the video and power cables in their original bag and put them in the dedicated cavity of the top buffer.
7. When applicable, put the display controller box in the dedicated cavity of the top buffer.
8. Put the system CD('s) and user guide in their original bag and place it in the dedicated cavity of the top buffer.
9. Close and seal the box.

7. CLEANING YOUR DISPLAY

7.1 Cleaning instructions

To clean the display

Clean the display using a sponge, cleaning cloth or soft tissue, lightly moistened with a recognized cleaning product for medical equipment. Read and follow all label instructions on the cleaning product. In case of doubt about a certain cleaning product, use plain water.

Do not use following products:

- Alcohol/solvents at higher concentration > 5%
- Strong alkalis lye, strong solvents
- Acid
- Detergents with fluoride
- Detergents with ammonia
- Detergents with abrasives
- Steel wool
- Sponge with abrasives
- Steel blades
- Cloth with steel thread



CAUTION: Take care not to damage or scratch the front glass or LCD. Be careful with rings or other jewelry and do not apply excessive pressure on the front glass or LCD.



CAUTION: Do not apply or spray liquid directly to the display as excess liquid may cause damage to internal electronics. Instead, apply the liquid to a cleaning cloth.

7. *Cleaning your display*

8. IMPORTANT INFORMATION

8.1 Safety information

General recommendations

Read the safety and operating instructions before operating the device.

Retain safety and operating instructions for future reference.

Adhere to all warnings on the device and in the operating instructions manual.

Follow all instructions for operation and use.

Electrical Shock or Fire Hazard

To prevent electric shock or fire hazard, do not remove cover.

No serviceable parts inside. Refer servicing to qualified personnel.

Do not expose this apparatus to rain or moisture.

Modifications to the unit:

Do not modify this equipment without authorization of the manufacturer.

Type of protection (electrical):

Display with external power supply: Class I equipment.

Degree of safety (flammable anesthetic mixture):

Equipment not suitable for use in the presence of a flammable anesthetic mixture with air or with oxygen or nitrous oxide.

Non-patient care equipment

- Equipment primarily for use in a health care facility that is intended for use where contact with a patient is unlikely (no applied part).
- The equipment may not be used with life support equipment.
- The user should not touch the equipment, nor its signal input ports (SIP)/signal output ports (SOP) and the patient at the same time.

Power connection – Equipment with external 24 VDC power supply

- Power requirements: The equipment must be powered using the delivered medical approved 24 VDC (≡) SELV power supply.
- The medical approved DC (≡) power supply must be powered by the AC mains voltage.
- The power supply is specified as a part of the ME equipment or combination is specified as a ME system.
- To avoid the risk of electric shock, this equipment must only be connected to a supply mains with protective earth.
- The equipment should be installed near an easily accessible outlet.
- The equipment is intended for continuous operation.

Transient over-voltage

If the device is not used for a long time, disconnect it from the AC inlet to avoid damage by transient over-voltage.

8. Important information

To fully disengage the power to the device, please disconnect the power cord from the AC inlet.

Power cords:

- Utilize a UL-listed detachable power cord, 3-wire, type SJ or equivalent, 18 AWG min., rated 250 V min., provided with a hospital-grade type plug 5-15P configuration for 120V application, or 6-15P for 240V application.
- Do not overload wall outlets and extension cords as this may result in fire or electric shock.
- Mains lead protection (U.S.: Power cord): Power cords should be routed so that they are not likely to be walked upon or pinched by items placed upon or against them, paying particular attention to cords at plugs and receptacles.
- Use a power cord that matches the voltage of the power outlet, which has been approved and complies with the safety standard of your particular country.

Water and moisture

Never expose the display to rain or moisture.

Never use the display near water - e.g. near a bathtub, washbasin, swimming pool, kitchen sink, laundry tub or in a wet basement.

Ventilation

Do not cover or block any ventilation openings in the cover of the set. When installing the device in a cupboard or another enclosed location, heed the necessary space between the set and the sides of the cupboard.

Installation

Place the device on a flat, solid and stable surface that can support the weight of at least 3 devices. If you use an unstable cart or stand, the device may fall, causing serious injury to a child or adult, and serious damage to the device.

This apparatus conforms to:

CE0120 (MDD 93/42/EEC; A1:2007/47/EC class IIb product), CE - 2014/30/EU, CE - 93/42/EEC; A1:2007/47/EC class II b, IEC 60950-1:2005 + A1:2009 (2ND EDITION), IEC 60601-1:2005 + C1:2006 + C2:2007 + A1:2012, ANSI/AAMI ES 60601-1:2005 + C1:2009 + R1:2012, CAN/CSA-C22.2 No. 60601-1:2014, DEMKO - EN 60601-1:2006 + A11:2011 + A12:2014 + A1: 2013, EN 60601-1-2:2007, CCC - GB9254-2008 + GB4943.1-2011 + GB17625.1-2003, KC, VCCI, FCC class B, ICES-001 Level B, FDA 510(k), RoHS

National Scandinavian Deviations for CL. 1.7.2:

Finland: "Laitte on liitettävä suojamaadoituskoskettimilla varustettuun pistorasiaan"

Norway: "Apparatet må tilkoples jordet stikkontakt"

Sweden: "Apparaten skall anslutas till jordat uttag"

8.2 Environmental information

Disposal Information

Waste Electrical and Electronic Equipment



■ This symbol on the product indicates that, under the European Directive 2012/19/EU governing waste from electrical and electronic equipment, this product must not be disposed of with other municipal waste. Please dispose of your waste equipment by handing it over to a designated collection point for the

recycling of waste electrical and electronic equipment. To prevent possible harm to the environment or human health from uncontrolled waste disposal, please separate these items from other types of waste and recycle them responsibly to promote the sustainable reuse of material resources.

For more information about recycling of this product, please contact your local city office or your municipal waste disposal service.

For details, please visit the Barco website at: <http://www.barco.com/en/AboutBarco/weee>

Turkey RoHS compliance



■ Türkiye Cumhuriyeti: AEEE Yönetmeliğine Uygundur.

[Republic of Turkey: In conformity with the WEEE Regulation]

中国大陆 RoHS

Chinese Mainland RoHS

根据中国大陆《电器电子产品有害物质限制使用管理办法》(也称为中国大陆RoHS), 以下部分列出了Barco产品中可能包含的有毒和/或有害物质的名称和含量。中国大陆RoHS指令包含在中国信息产业部MCV标准:“电子信息产品中有毒物质的限量要求”中。

According to the “Management Methods for the Restriction of the Use of Hazardous Substances in Electrical and Electronic Products” (Also called RoHS of Chinese Mainland), the table below lists the names and contents of toxic and/or hazardous substances that Barco’s product may contain. The RoHS of Chinese Mainland is included in the MCV standard of the Ministry of Information Industry of China, in the section “Limit Requirements of toxic substances in Electronic Information Products”.

零件项目(名称) Component name	有毒有害物质或元素 Hazardous substances and elements					
	铅 Pb	汞 Hg	镉 Cd	六价铬 Cr6+	多溴联苯 PBB	多溴二苯醚 PBDE
印制电路配件 Printed Circuit Assemblies	x	o	o	o	o	o
液晶面板 LCD panel	x	o	o	o	o	o
外接电(线)缆 External Cables	x	o	o	o	o	o
内部线路 Internal wiring	o	o	o	o	o	o
金属外壳 Metal enclosure	o	o	o	o	o	o
塑胶外壳 Plastic enclosure	o	o	o	o	o	o
散热片(器) Heatsinks	o	o	o	o	o	o
电源供应器 Power Supply Unit	x	o	o	o	o	o
风扇 Fan	o	o	o	o	o	o
文件说明书 Paper Manuals	o	o	o	o	o	o

8. Important information

零件项目(名称) Component name	有毒有害物质或元素 Hazardous substances and elements					
	铅 Pb	汞 Hg	镉 Cd	六价铬 Cr6+	多溴联苯 PBB	多溴二苯醚 PBDE
光盘说明书 CD manual	0	0	0	0	0	0
本表格依据SJ/T 11364的规定编制 This table is prepared in accordance with the provisions of SJ/T 11364. 0: 表示该有毒有害物质在该部件所有均质材料中的含量均在 GB/T 26572 标准规定的限量要求以下。 0: Indicates that this toxic or hazardous substance contained in all of the homogeneous materials for this part is below the limit requirement in GB/T 26572. x: 表示该有毒有害物质至少在该部件的某一均质材料中的含量超出 GB/T 26572 标准规定的限量要求。 x: Indicates that this toxic or hazardous substance contained in at least one of the homogeneous materials used for this part is above the limit requirement in GB/T 26572.						

在中国大陆销售的相应电子信息产品(EIP)都必须遵照中国大陆《电子电气产品有害物质限制使用标识要求》标准贴上环保使用期限(EFUP)标签。Barco产品所采用的EFUP标签(请参阅实例,徽标内部的编号用于指定产品)基于中国大陆的《电子信息产品环保使用期限通则》标准。

All Electronic Information Products (EIP) that are sold within Chinese Mainland must comply with the "Marking for the restriction of the use of hazardous substances in electrical and electronic product" of Chinese Mainland, marked with the Environmental Friendly Use Period (EFUP) logo. The number inside the EFUP logo that Barco uses (please refer to the photo) is based on the "General guidelines of environment-friendly use period of electronic information products" of Chinese Mainland.



8.3 Regulatory compliance information

Indications for use

The Nio 3MP LED Display is intended to be used as a tool in displaying and viewing digital images (excluding digital mammography) for review and analysis by trained medical practitioners. Caution (USA): Federal law restricts this device to sale by or on the order of a physician. (Details & exemptions are in the Code of Federal Regulations Title 21, 801 Part D).

FCC class B

This device complies with Part 15 of the FCC Rules. Operation is subject to the following two conditions: (1) this device may not cause harmful interference, and (2) this device must accept any interference received, including interference that may cause undesired operation.

This device has been tested and found to comply with the limits for a Class B digital device, pursuant to Part 15 of the FCC Rules. These limits are designed to provide reasonable protection against harmful interference in a residential installation. This device generates, uses and can radiate radio frequency energy and, if not installed and used in accordance with the instructions, may cause harmful interference to radio communications. However, there is no guarantee that interference will not occur in a particular installation. If this device does cause harmful interference to radio or television reception, which can be determined by turning the device off and on, the user is encouraged to try to correct the interference by one or more of the following measures:

- Reorient or relocate the receiving antenna.
- Increase the separation between the device and receiver.
- Connect the device into an outlet on a circuit different from that to which the receiver is connected.
- Consult the dealer or an experienced radio/TV technician for help.

Changes or modifications not expressly approved by the party responsible for compliance could void the user's authority to operate the equipment.

Canadian notice

CAN ICES-1/NMB-1

8.4 EMC notice

General information

No specific requirement on the use of external cables or other accessories except power supply.

With the installation of the device, use only the delivered power supply or a spare part provided by the legal manufacturer. Using another can result in a decrease of the immunity level of the device.

Electromagnetic emissions

The Nio 3MP LED Display is intended for use in the electromagnetic environment specified below. The customer or the user of the Nio 3MP LED Display should assure that it is used in such an environment.

Emissions test	Compliance	Electromagnetic environment – Guidance
RF emissions CISPR 11	Group 1	The Nio 3MP LED Display uses RF energy only for its internal function. Therefore, its RF emissions are very low and are not likely to cause any interference in nearby electronic equipment.
RF emissions CISPR 11	Class B	The Nio 3MP LED Display is suitable for use in all establishments, including domestic establishments and those directly connected to the public low-voltage power supply network that supplies buildings used for domestic purposes.
Harmonic emissions IEC 61000-3-2	Class D	
Voltage fluctuations/ flicker emissions IEC 61000-3-3	Complies	

This Nio 3MP LED Display complies with appropriate medical EMC standards on emissions to, and interference from surrounding equipment. Operation is subject to the following two conditions: (1) this device may not cause harmful interference, and (2) this device must accept any interference received, including interference that may cause undesired operation.

Interference can be determined by turning the equipment off and on.

If this equipment does cause harmful interference to, or suffer from harmful interference of, surrounding equipment, the user is encouraged to try to correct the interference by one or more of the following measures:

- Reorient or relocate the receiving antenna or equipment.
- Increase the separation between the equipment and receiver.
- Connect the equipment into an outlet on a circuit different from that to which the receiver is connected.
- Consult the dealer or an experienced technician for help.

8. Important information

Electromagnetic immunity

The Nio 3MP LED Display is intended for use in the electromagnetic environment specified below. The customer or the user of the Nio 3MP LED Display should assure that it is used in such an environment.

Immunity test	IEC 60601 Test levels	Compliance level	Electromagnetic environment – guidance
Electrostatic discharge (ESD) IEC 61000-4-2	± 6kV contact ± 8kV air	± 6kV contact ± 8kV air	Floors should be wood, concrete or ceramic tile. If floors are covered with synthetic material, the relative humidity should be at least 30%
Electrical fast transient/burst IEC 61000-4-4	± 2kV for power supply lines ± 1kV for input/ output lines	± 2kV for power supply lines ± 1kV for input/ output lines	Mains power quality should be that of a typical commercial or hospital environment
Surge IEC61000-4-5	± 1 kV line(s) to line(s) ± 2 kV line(s) to earth	± 1 kV line(s) to line(s) ± 2 kV line(s) to earth	Mains power quality should be that of a typical commercial or hospital environment
Voltage dips, short interruptions and voltage variations on power supply input lines IEC 61000-4-11	< 5% U_T ⁵ (> 95% dip in U_T) for 0.5 cycle 40% U_T (60% dip in U_T) for 5 cycles 70% U_T (30% dip in U_T) for 25 cycles < 5% U_T (>95% dip in U_T) for 5s	< 5% U_T (> 95% dip in U_T) for 0.5 cycle 40% U_T (60% dip in U_T) for 5 cycles 70% U_T (30% dip in U_T) for 25 cycles < 5% U_T (>95% dip in U_T) for 5s	Mains power quality should be that of a typical commercial or hospital environment. If the user of the Nio 3MP LED Display requires continued operation during power mains interruptions, it is recommended that the Nio 3MP LED Display be powered from an uninterruptible power supply or a battery.
Power frequency (47-63 Hz) magnetic field IEC 61000-4-8	3 A/m	Not applicable ⁶	Power frequency magnetic fields should be at levels characteristic of a typical location in a typical commercial or hospital environment.
Conducted RF IEC 61000-4-6 Radiated RF IEC 61000-4-3	3 Vrms 150 kHz to 80 MHz 3 V/m 80 MHz to 2.5 GHz	3 V 3 V/m	Portable and mobile RF communications equipment should be used no closer to any part of the Nio 3MP LED Display, including cables, than the recommended separation distance calculated from the equation applicable to the frequency of the transmitter. Recommended separation distance $d = 1.2\sqrt{P}$

5. is the a.c. mains voltage prior to application of the test level.

6. Nio 3MP LED Display doesn't contain susceptible components to magnetic fields

Immunity test	IEC 60601 Test levels	Compliance level	Electromagnetic environment – guidance
			<p>d = 1.2√P 80 MHz to 800 MHz</p> <p>d = 2.3√P 800 MHz to 2.5 Ghz</p> <p>Where P is the maximum output power rating of the transmitter in watts (W) according to the transmitter manufacturer and d is the recommended separation distance in meters (m).</p> <p>Field strengths from fixed RF transmitters, as determined by an electromagnetic site survey,⁷ should be less than the compliance level in each frequency range.⁸</p> <p>Interference may occur in the vicinity of equipment marked with symbol:</p> 



At 80 MHz and 800 MHz, the higher frequency range applies.



These guidelines may not apply in all situations. Electromagnetic propagation is affected by absorption and reflection from structures, objects and people.

Recommended separation distance

The Nio 3MP LED Display is intended for use in an electromagnetic environment in which radiated RF disturbances are controlled. The customer of the user of the Nio 3MP LED Display can help prevent electromagnetic interference by maintaining a minimum distance between portable and mobile RF communications equipment (transmitters) and the Nio 3MP LED Display as recommended below, according to the maximum output power of the communications equipment.

7. Field strengths from fixed transmitters, such as base stations for radio (cellular/cordless) telephones and land mobile radios, amateur radio, AM and FM radio broadcast and TV broadcast cannot be predicted theoretically with accuracy. To assess the electromagnetic environment due to fixed RF transmitters, an electromagnetic site survey should be considered. If the measured field strength in the location in which the Nio 3MP LED Display is used exceeds the applicable RF compliance level above, the Nio 3MP LED Display should be observed to verify normal operation. If abnormal performance is observed, additional measures may be necessary, such as re-orienting or relocating the Nio 3MP LED Display.

8. Over the frequency range 150 kHz to 80 MHz, field strengths should be less than 3 V/m.

8. Important information

Rated maximum output power of transmitter ⁹ W	Separation distance according to frequency of transmitter		
	150kHz to 80MHz $d=1.2\sqrt{P}$	80MHz to 800MHz $d=1.2\sqrt{P}$	800MHz to 2.5GHz $d=2.3\sqrt{P}$
0.01	0.12	0.12	0.23
0.1	0.38	0.38	0.73
1	1.2	1.2	2.3
10	3.8	3.8	7.3
100	12	12	23



At 80 MHz and 800 MHz, the separation distance for the higher frequency range applies.



These guidelines may not apply in all situations. Electromagnetic propagation is affected by absorption and reflection from structures, object and people.















8.5 Explanation of symbols

Symbols on the device

On the device or power supply, you may find the following symbols (nonrestrictive list):

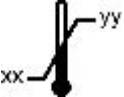





	Indicates compliance with the Directive 93/42/EEC as Class I device
	Indicates compliance with the Directive 93/42/EEC as Class II device
	Indicates compliance with Part 15 of the FCC rules (Class A or Class B)
	Indicates the device is approved according to the UL regulations
	Indicates the device is approved according to the UL regulations for Canada and US
	Indicates the device is approved according to the UL regulations for Canada and US

9. For transmitters rated at a maximum output power not listed above, the recommended separation distance d in meters (m) can be estimated using the equation applicable to the frequency of the transmitter. Where P is the maximum output power rating of the transmitter in watts (W) according to the transmitter manufacturer.

	Indicates the device is approved according to the UL Demko regulations
	Indicates the device is approved according to the CCC regulations
	Indicates the device is approved according to the VCCI regulations
	Indicates the device is approved according to the KC regulations
	Indicates the device is approved according to the BSMI regulations
	Indicates the device is approved according to the PSE regulations
	Caution: Federal law (United States of America) restricts this device to sale by or on the order of a licensed healthcare practitioner.
	Indicates the USB connectors on the device
	Indicates the DisplayPort connectors on the device
	Indicates the legal manufacturer
	Indicates the manufacturing date
	Indicates the temperature limitations ¹⁰ for the device to safely operate within specs
	Indicates the device serial number
	Indicates the device part number or catalogue number
	Warning: dangerous voltage





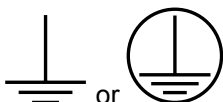

10. Values for xx and yy can be found in the technical specifications paragraph.

8. Important information

	Caution
	Consult the operating instructions
	Indicates this device must not be thrown in the trash but must be recycled, according to the European WEEE (Waste Electrical and Electronic Equipment) directive
	Indicates Direct Current (DC)
	Indicates Alternating Current (AC)
	Stand-by
	Equipotentiality
	Protective earth (ground)

Symbols on the box

On the box of the device, you may find the following symbols (nonrestrictive list):

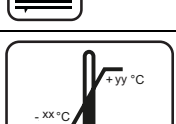
	Indicates a medical device that can be broken or damaged if not handled carefully when being stored.
	Indicates a medical device that needs to be protected from moisture when being stored.
	Indicates the storage direction of the box. The box must be transported, handled and stored in such a way that the arrows always point upwards.
	Indicates the maximum number of boxes to be stacked on each other.
	Indicates that the box should be carried with two persons.
	Indicates that the box should not be cut with a knife, a cutter or any other sharp object.
	Indicates the temperature limits to which the medical device can be safely exposed when being stored.

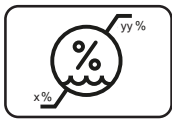
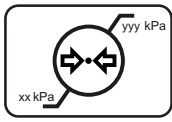
	Indicates the range of humidity to which the medical device can be safely exposed when being stored.
	Indicates the range of atmospheric pressure to which the medical device can be safely exposed when being stored.

8.6 Legal disclaimer

Disclaimer notice

Although every attempt has been made to achieve technical accuracy in this document, we assume no responsibility for errors that may be found. Our goal is to provide you with the most accurate and usable documentation possible; if you discover errors, please let us know.

Barco software products are the property of Barco. They are distributed under copyright by Barco NV or Barco Inc., for use only under the specific terms of a software license agreement between Barco NV or Barco Inc. and the licensee. No other use, duplication, or disclosure of a Barco software product, in any form, is authorized.

The specifications of Barco products are subject to change without notice.

Trademarks

All trademarks and registered trademarks are property of their respective owners.

Copyright notice

This document is copyrighted. All rights are reserved. Neither this document, nor any part of it, may be reproduced or copied in any form or by any means - graphical, electronic, or mechanical including photocopying, taping or information storage and retrieval systems - without written permission of Barco.

© 2016 Barco NV all rights reserved.

Patent information

This product is covered under the following intellectual property rights:

US Patent RE43,707

European Patent 1 915 875

8.7 Technical specifications

Overview

Screen technology	IPS-TFT Color LCD
Active screen size (diagonal)	540 mm (21.3")
Active screen size (H x V)	432 x 324 mm (17.0 x 12.8")
Aspect ratio (H:V)	4:3
Resolution	3MP (2048 x 1536 pixels)
Pixel pitch	0.2109 mm
Color imaging	Yes

8. Important information

Gray imaging	Yes
Bit depth	30 bit
Viewing angle (H, V)	178°
Uniform Luminance Technology (ULT)	Color PZU
Ambient Light Compensation (ALC)	Yes, reading room selection
Backlight Output Stabilization (BLOS)	No
Front sensor	Yes
Maximum luminance (panel typical)	900 cd/m ²
DICOM calibrated luminance	500 cd/m ²
Contrast ratio (panel typical)	1400:1
Response time (Tr + Tf) (typical)	20 ms
Housing color	RAL 9003 / RAL 9004
Video input signals	DVI-D Dual Link DisplayPort
USB ports	1x USB 2.0 upstream (endpoint) 2x USB 2.0 downstream
Power Requirements	External power supply (100-240 Vac, 47-63 Hz)
Power consumption	50 W (nominal) < 0.5 W (standby)
OSD languages	English, German, French, Dutch, Spanish, Italian, Portuguese, Polish, Russian, Swedish, Chinese (simplified), Japanese, Korean, Arabic
Dimensions with stand (W x H x D)	Portrait: 378 x 528~628 x 235 mm Landscape: 491 x 472~572 x 235 mm
Dimensions wo stand (W x H x D)	Portrait: 378 x 491 x 84 mm Landscape: 491 x 378 x 84 mm
Dimensions packaged (W x H x D)	500 x 280 x 670 mm
Net weight with stand	11.2 kg
Net weight w/o stand	6.2 kg
Net weight packaged	15.7 kg (without accessories)
Tilt	-10° to +30°
Swivel	-45° to +45°
Pivot	90°
Height adjustment range	100 mm
Mounting standard	VESA (100 mm)
Screen protection	Protective, anti-reflective glass cover
Recommended modalities	All digital images, except digital mammography

Certifications	CE0120 (MDD 93/42/EEC; A1:2007/47/EC class IIb product), CE 2014/30/EU, CE93/42/EEC; A1:2007/47/EC class II b, IEC 609501:2005 + A1:2009 (2NDEDITION), IEC 606011:2005 + C1:2006 + C2:2007 + A1:2012, ANSI/AAMI ES606011:2005 + C1:2009 + R1:2012, CAN/CSAC22.2No. 606011:2014, DEMKO EN606011:2006 + A11:2011 + A12:2014 + A1: 2013, EN 6060112:2007, CCC GB92542008+ GB4943.12011+ GB17625.12003,KC, VCCI, FCC class B, ICES001Level B, FDA 510(k), RoHS
Supplied accessories	User guide Documentation disc System disc Video cable (1 x DisplayPort) Mains cables (UK, European (CEBEC/KEMA), USA (UL/CSA; adaptor plug NEMA515P),Chinese (CCC)) USB 2.0 cable External power supply
Optional accessories	Graphics board
QA software	MediCal QAWeb
Warranty	5 years, including 20000 hrs backlight warranty
Operating temperature	0 °C to 40 °C (15 °C to 35 °C within specs)
Storage temperature	-20 °C to 60 °C
Operating humidity	8% to 80% (non-condensing)
Storage humidity	5% to 85% (non-condensing)
Operating pressure	70 kPa minimum
Storage pressure	50 to 106 kPa

8.8 Open source license information

Open source license information

This product contains software components released under an Open Source license. You acknowledge living up to the conditions of each separate Open Source Software license.

A list of the Open Source Software components used is available in the applicable EULA, through the “My Barco” section of the Barco website or through other (online) means.

Copyright on each Open Source Software component belongs to the respective initial copyright holder, each additional contributor and/or their respective assignee(s), as may be identified in the respective Open Source Software documentation, source code, README file, or otherwise. You shall not remove or obscure or otherwise alter the respective copyrights.

EACH SEPARATE OPEN SOURCE SOFTWARE COMPONENT AND ANY RELATED DOCUMENTATION ARE PROVIDED "AS IS" WITHOUT EXPRESS OR IMPLIED WARRANTY INCLUDING, BUT NOT LIMITED TO, THE IMPLIED WARRANTIES OF MERCHANTABILITY AND FITNESS FOR A PARTICULAR PURPOSE. IN NO EVENT SHALL THE COPYRIGHTHOLDER OR ANY OTHER CONTRIBUTOR BE LIABLE FOR DIRECT, INCIDENTAL, SPECIAL, EXEMPLARY OR CONSEQUENTIAL DAMAGES, EVEN IF ADVISED OF THE POSSIBILITY OF SUCH DAMAGES, HOWEVER CAUSED AND ON ANY THEORY OF LIABILITY. MORE INFORMATION/DETAILS IS TO BE FOUND IN EACH SPECIFIC OPEN SOURCE LICENSE.

With respect to GPL, LGPL or similar licenses with regard to corresponding source code access and automatic license terms applicability:

8. Important information

- You acknowledge living up to the conditions of each such specific applicable Open Source Software license. You are responsible for your own additions, changes or modifications without any recourse or claim towards Barco whatsoever. You further acknowledge that any such additions, changes or modifications may impair the ability of Barco – at Barco’s sole discretion - to continue to provide service, warranties, software updates, fixes, maintenance, access or such similar abilities, without any recourse or claim towards Barco whatsoever.
- Barco offers to provide the corresponding source code, and shall make the corresponding source code available to you via email or download link, except where the applicable license entitles you to require Barco to provide you the corresponding source code on a tangible medium, in which case Barco will charge you for the actual costs of performing such distribution, such as the cost of media, shipping and handling. You may exercise this option upon written request to Barco N.V, attn. legal department, President Kennedypark 35, 8500 Kortrijk (Belgium). This offer is valid for a period of three (3) years from the date of the distribution of this product by Barco.