

InTouch 32™ Secure Tablet Locker

55434

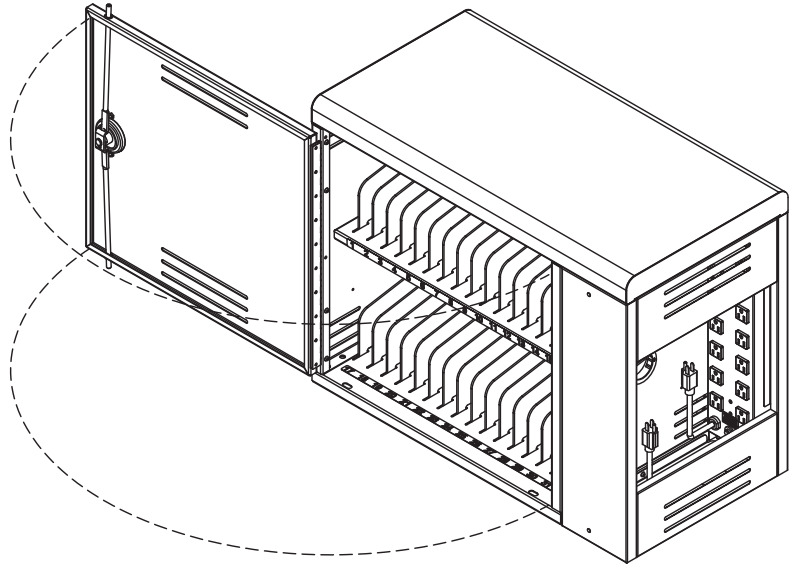
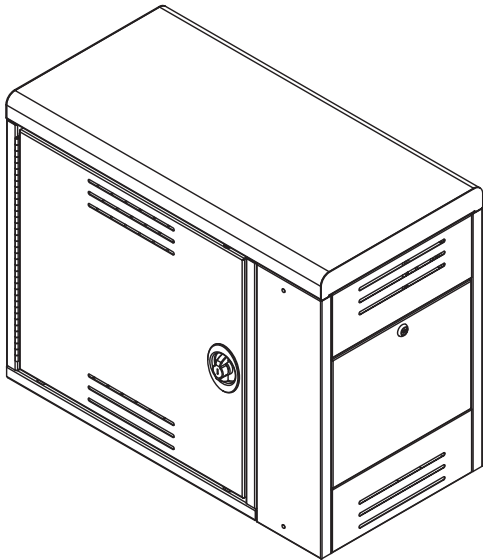

⚠ Important ⚠

Before using this product:

- Read this manual
- Comply with all safety and operating instructions
- Ensure all parts and correct quantities are included

Any parts damaged during shipment must be reported within 15 days of receipt. To report information regarding missing parts or damage, to purchase parts or accessories, or if you have any questions, please contact us.

Thank you for purchasing Spectrum products!

Spectrum Industries, Inc
925 First Avenue, Chippewa Falls, WI 54729 USA
800 235 1262
715 723 6750
www.spectrumfurniture.com



Important Safety and Care Instructions



- Read this owner's manual before assembly or operation.
- Do not allow children to operate.
- For indoor use only. Do not install or store where it will be exposed to moisture.
- Do not block the ventilation openings.
- Do not allow anyone to sit, stand, or climb on the unit.
- Use a damp, soft-cloth, or sponge, with mild soap or detergent solution to clean dirty surfaces. Do not use harsh solvents or abrasives.
- This unit is intended for institutional use. It does not have any user-serviceable parts or user-maintenance requirements. If servicing is necessary, please contact Spectrum Industries for assistance.

Warning - Relocating audio and/or video equipment to furniture not specifically designed to support audio and/or video equipment may result in death or serious injury due to the furnishing collapsing or over turning onto a child.

Warning - Death or serious injury may occur when children climb on audio and/or video equipment furniture. A remote control or toys placed on the furnishing may encourage a child to climb on the furnishing and as a result the furnishing may tip over on to the child.

Electrical Safety:

- Keep the power switches in the OFF position before plugging or unplugging from the wall outlet.
- Turn OFF the devices before plugging them in.
- Ensure total device / equipment load does not exceed 12-amperes.
- Do not plug the power cord into an extension cord.
- Inspect the power cords for damage before each use. Do not use power cords that are damaged.
- Unplug power cord from electrical outlet by gripping the cord. Do not unplug the power cord by pulling only on the cord.
- Do not step on, drive over, drag, or place objects on the power cord.
- For added safety, plug the cart into a grounded outlet controlled by a GFI (Ground Fault Interrupter) circuit breaker.
- Damaged electrical components can create significant hazards to users and is not covered by the warranty. Repairs should always be performed by a qualified electrician.
- Electrical devices are not toys. Children are often unaware of the hazards associated with electrical devices. This unit must always be used by adults or with adult supervision.

IT32 tablet locker security

A. Worksurface anchoring

Four 3/8" holes are provided on the bottom panel to anchor the locker to a worksurface for increased security. *Fasteners are not included.* (Cords from 16-outlet power units will route through side panel).

1. Set the locker into its final position. (If attaching to a table or worksurface, be sure it is stable and sturdy enough to fully support the unit.)
2. Choose fasteners appropriate to the surface you will be attaching to. The (4) mounting holes in the bottom panel are 3/8" dia. **Figure 1A.**
3. Mark the (4) hole locations through bottom panel.
4. At the marked locations, drill holes in the worksurface appropriate to the chosen fastener type and size.
5. Install fasteners and tighten securely.

3/8" holes for customer-supplied fasteners

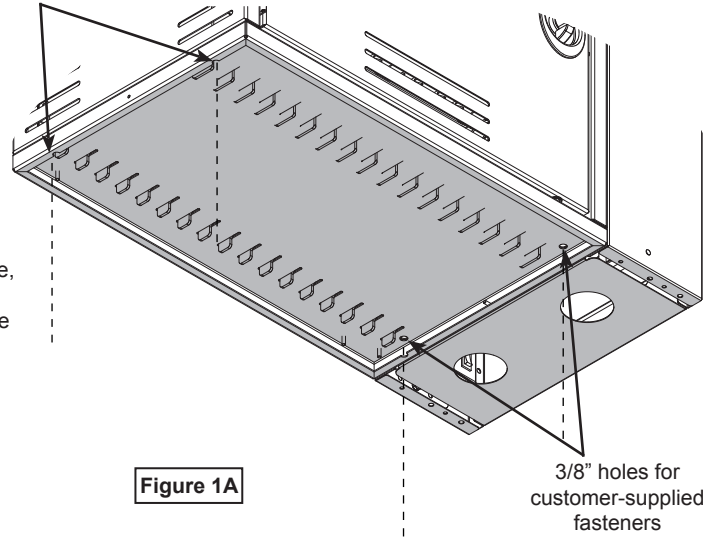

Figure 1A

3/8" holes for customer-supplied fasteners

B. Wall-mounting

The locker back panel has four 3/8" holes located 16" on-center to match most stud-wall applications. *Fasteners are not included.* (Cords from 16-outlet power units will route through bottom panel.)

1. Choose fasteners appropriate to the wall you will be anchoring to.
2. Determine the preferred wall location and height from floor.
3. Measure and mark the (4) hole locations on the wall. **Figure 1B.** Be sure fasteners will be anchored securely to studs or other solid portion of the wall.
4. At the marked wall locations, drill holes appropriate to the chosen fastener type and size.
5. Support the locker (this may take 2-3 people), align the mounting holes, install fasteners, and tighten to secure the locker to the wall. **Figure 1C.**



WARNING



It is the customers responsibility to use appropriate and adequate wall fasteners when attaching the IT32 Tablet Locker to a wall. Nominal weight of an empty IT32 is 76 lbs. Total loaded weight will vary with quantity & types of tablets used.

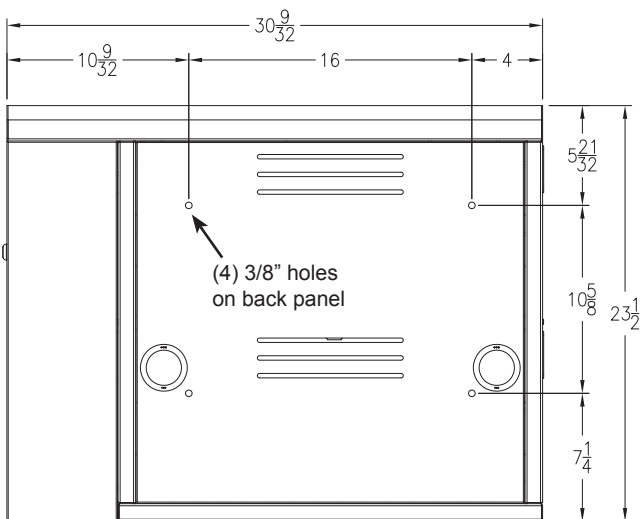

Figure 1B

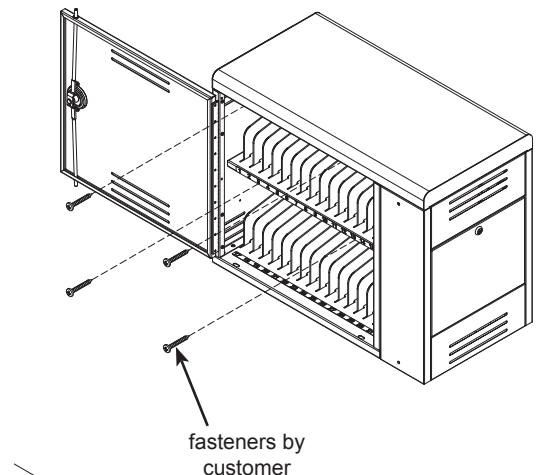

Figure 1C

Power-side wiring

1. To gain access to the power-side, unlock & remove the side panel. **Figure 2A.**
2. Be sure both 16-outlet power units are unplugged and switched off.
3. Plug up to 32 tablet chargers into the power units. **Figure 2B.**
4. Route the charge cords through the upper & lower divider panel cutouts and into the tablet storage area.

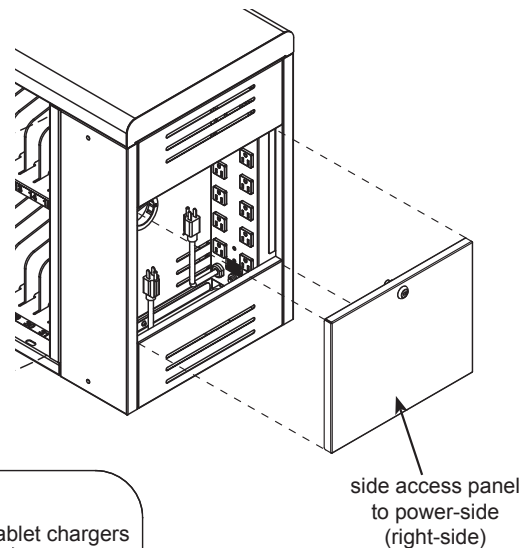

Figure 2A

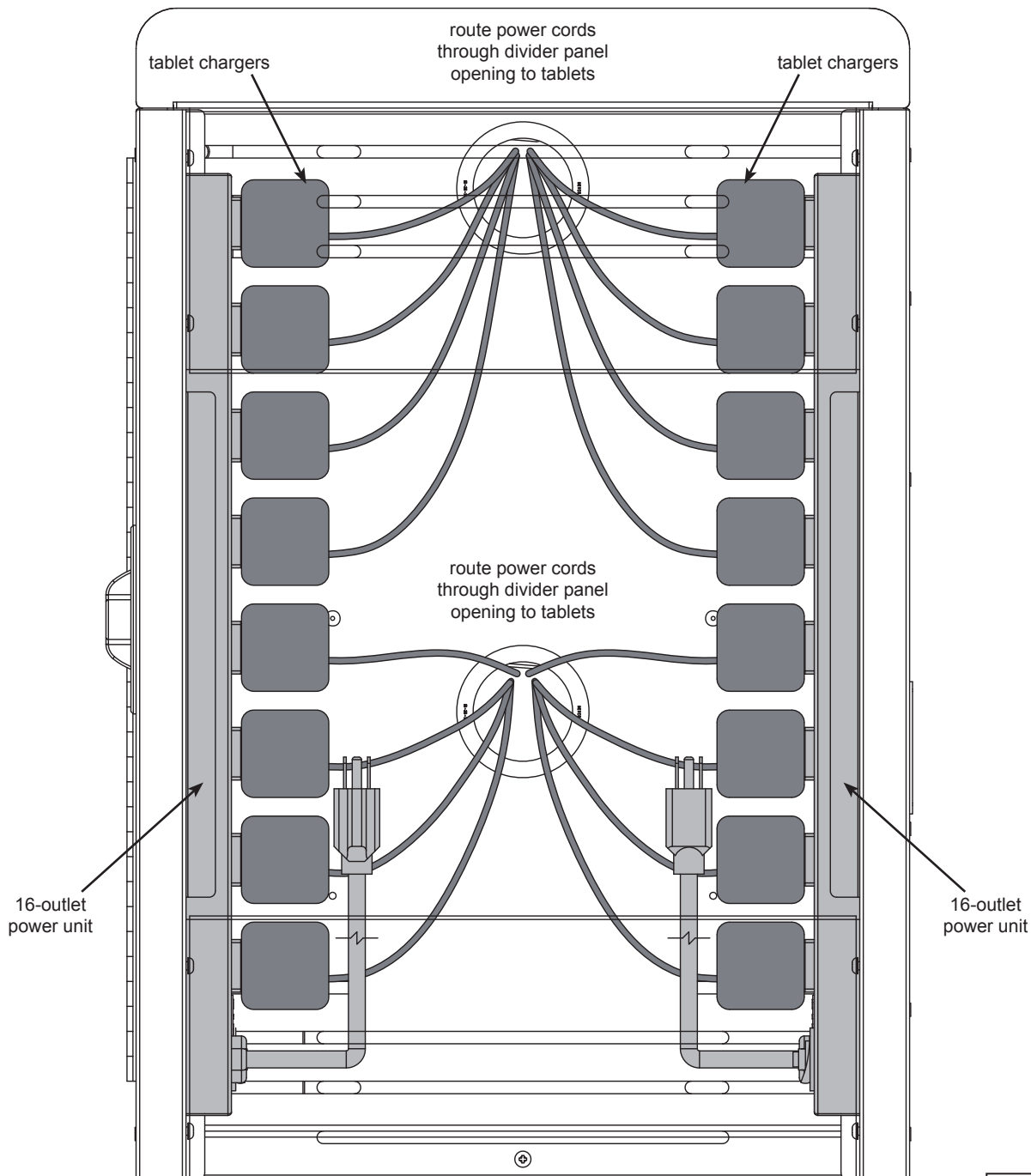

Figure 2B

Routing power cords to tablets

Tablet power cords need to be 3' or longer to use the recommended cord management method shown in the wiring diagram below. **Figure 3A.**

1. Use the cord management wraps above each tablet storage slot, wrap excess cord while leaving enough cord length to drop down to each tablet. **Figure 3A-B.**

cord management wraps

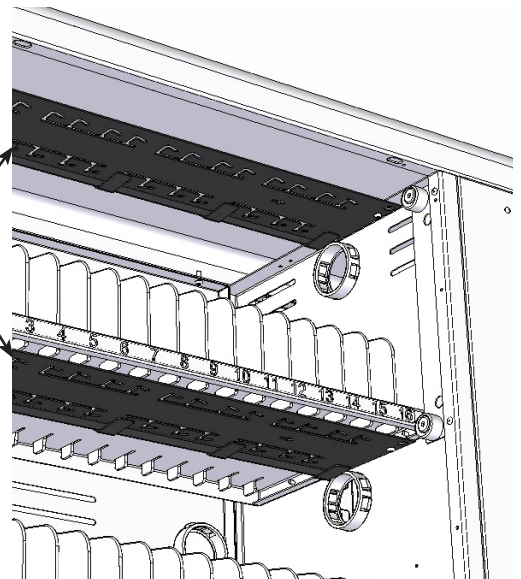

Figure 3B

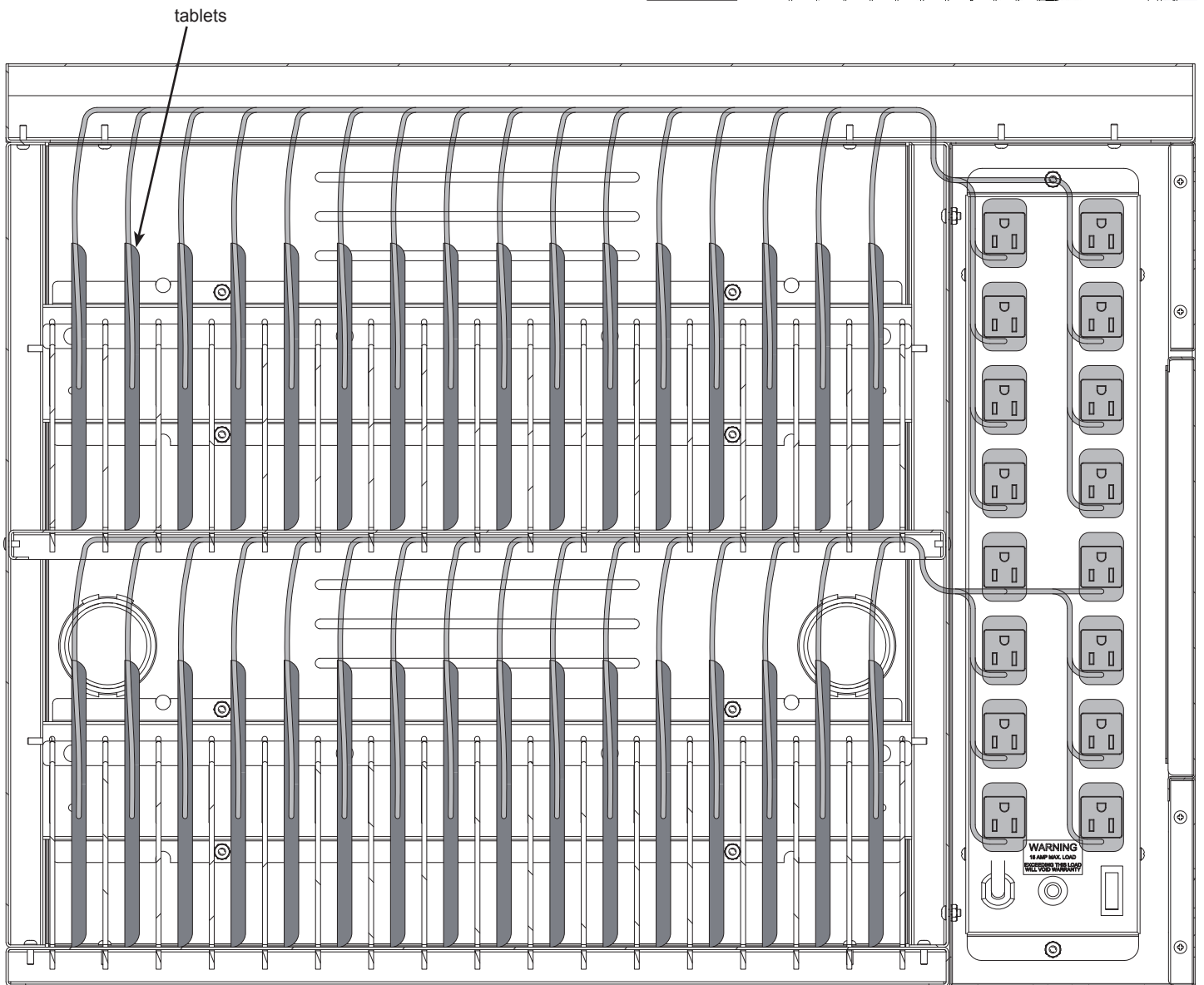

Figure 3A

16-outlet power unit(s)
w/ tablet chargers

2. Set tablets into slots. **Figure 3C.**
3. Plug charge cords into tablets.
4. Plug 16-outlet power units into wall outlets and switch on to begin charging.

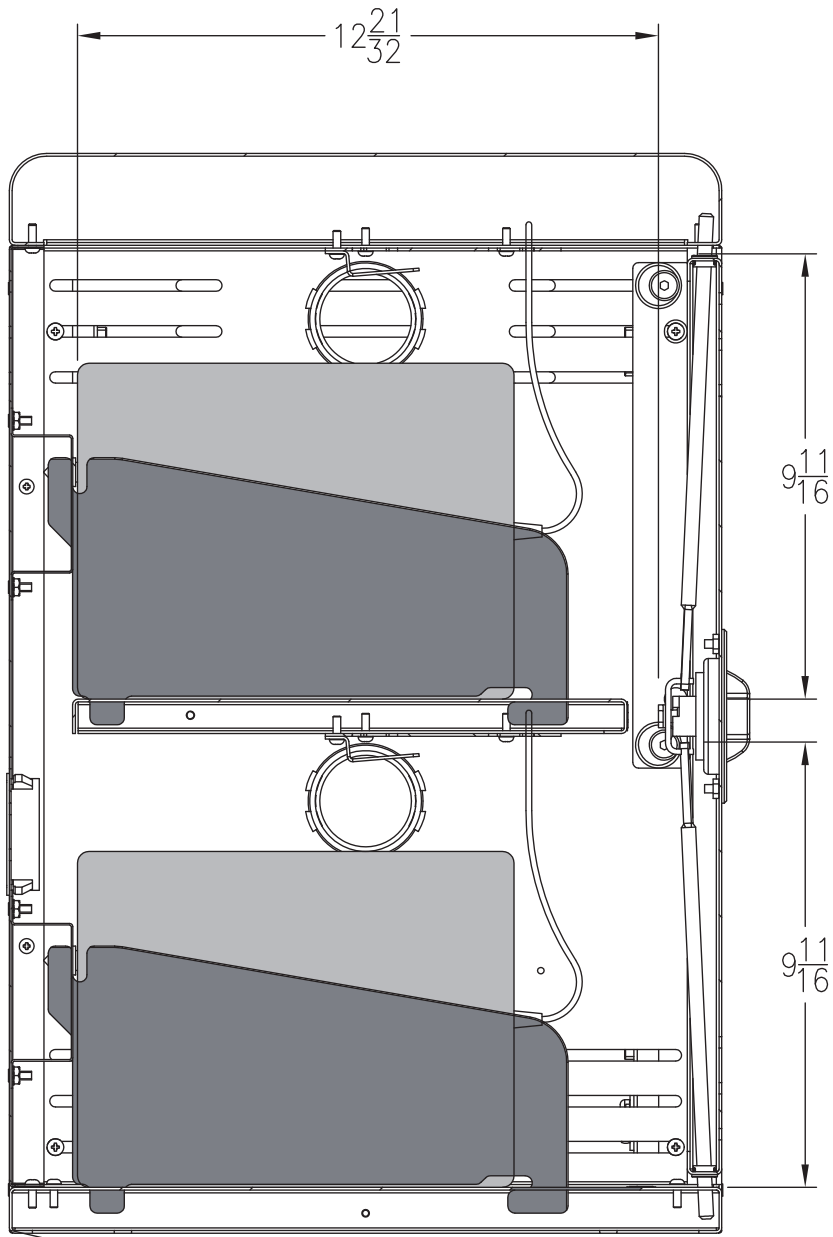

Figure 3C

Door stop adjustment

If necessary, the offset door stop can be rotated slightly to adjust the closed position of the doors and lock rods.

1. To rotate, loosen the JC bolt slightly with a 4mm hex wrench. **Figure 4.**
2. Rotate the door stop until the door is positioned correctly.
3. Re-tighten the JC bolt securely.

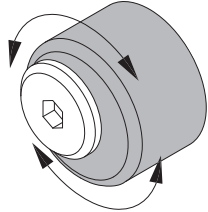



Figure 4

Tools Required		4mm hex wrench
----------------	---	----------------

Warranty Statement

WE WILL MAKE IT RIGHT FOR YOU!

Spectrum is committed to provide complete customer satisfaction. Each of our products is manufactured from the best materials available and each product is stringently monitored throughout the production process through our P.A.C.E. program (Product Assurance to meet Customer Expectations).

We expressly warrant that Spectrum products will be of good quality and workmanship and free from defect for the period set out in the warranty table below from the date of delivery. This warranty shall not apply to defects or damage resulting from misuse, abuse, neglect, improper care, modification or repair not authorized by Spectrum, or any other cause outside the control of Spectrum. Spectrum will, at its sole option, either repair or replace the defective product.

This warranty is exclusive; no other warranty, written or oral, is expressed or implied. This warranty is given by Spectrum to Buyer and to no other person or legal entity. No Spectrum dealer, distributor, agent or employee is authorized to make any modification or addition to this warranty.

NOTWITHSTANDING ANYTHING TO THE CONTRARY, SPECTRUM WILL NOT UNDER ANY CIRCUMSTANCES BE LIABLE FOR INDIRECT OR LIQUIDATED DAMAGES, INCLUDING CONSEQUENTIAL, INCIDENTAL AND SPECIAL DAMAGES. IN NO EVENT SHALL SPECTRUM'S LIABILITY, WHETHER UNDER CONTRACT OR WARRANTY, IN TORT OR OTHERWISE, EXCEED THE PURCHASE PRICE RECEIVED BY SPECTRUM FOR THE PRODUCT AT ISSUE AND "RECALL ACTION" EXPENSES. SPECTRUM SHALL NOT BE SUBJECT TO ANY OTHER OBLIGATIONS OR LIABILITIES, WHETHER ARISING OUT OF BREACH OF CONTRACT, WARRANTY, TORT (INCLUDING NEGLIGENCE AND STRICT LIABILITY) OR OTHER THEORIES OF LAW, WITH RESPECT TO PRODUCTS SOLD OR SERVICES RENDERED BY SPECTRUM, OR ANY UNDERTAKINGS, ACTS OR OMISSIONS RELATING THERETO.

Our Customer Service Department is ready to provide immediate attention to any questions, comments or concerns. They are available to answer your calls Monday through Friday from 7 am to 5 pm CST. In addition your product comments or concerns are welcome via e-mail at: spectrum@spectrumfurniture.com.

Warranty Table

Item	Warranty Period
<ul style="list-style-type: none"> • Adjustable Crank/Electric Desk Legs • Flat Panel Desk Gas Cylinders 	<ul style="list-style-type: none"> • 1 Year
<ul style="list-style-type: none"> • Adjustable Height Chair Parts – including frames, gas cylinders, wood and plastic parts, and control handles Adjustable Height Chair Parts Casters • Adjustable Height Chair Upholstery • In-Stock Upholstery • Graded-In Fabrics and Customer Owned Material 	<ul style="list-style-type: none"> • 7 Years • 2 Years • 2 Years • No Warranty
<ul style="list-style-type: none"> • Height Adjustable Columns and Lifts • General Use Casters • Electrical • Keyboard/Mouse Trays 	<ul style="list-style-type: none"> • 1 Year
<ul style="list-style-type: none"> • Flat Panel Monitor Arm – General Parts • Flat Panel Monitor Arm – Gas Cylinders 	<ul style="list-style-type: none"> • 5 Years • 2 Years
<ul style="list-style-type: none"> • Computer Desk Chassis • Cart Chassis • Lectern Chassis 	<ul style="list-style-type: none"> • 10 Years

