

POS X

POINT OF SALE SIMPLIFIED



ION TP5 Pro

All-In-One Terminal

User's Manual

The information contained in this document is subject to change without notice. We make no warranty of any kind with regard to this material, including, but not limited to, the implied warranties of merchantability and fitness for a particular purpose. We shall not be liable for errors contained herein or for incidental or consequential damages in connection with the furnishing, performance, or use of this material.

This document contains proprietary information that is protected by copyright. All rights are reserved. No part of this document may be photocopied, reproduced or translated to another language without the prior written consent of the manufacturer.

TRADEMARK

Intel®, Pentium® and MMX are registered trademarks of Intel® Corporation. Microsoft® and Windows® are registered trademarks of Microsoft Corporation. Other trademarks mentioned herein are the property of their respective owners.

Safety

IMPORTANT SAFETY INSTRUCTIONS

1. To disconnect the machine from the electrical power supply, turn off the power switch and remove the power cord plug from the wall socket. The wall socket must be easily accessible and in close proximity to the machine.
2. Read these instructions carefully. Save these instructions for future reference.
3. Follow all warnings and instructions marked on the product.
4. Do not use this product near water.
5. Do not place this product on an unstable cart, stand, or table. The product may fall, causing serious damage to the product.
6. Slots and openings in the cabinet and the back or bottom are provided for ventilation to ensure reliable operation of the product and to protect it from overheating. These openings must not be blocked or covered. The openings should never be blocked by placing the product on a bed, sofa, rug, or other similar surface. This product should never be placed near or over a radiator or heat register or in a built-in installation unless proper ventilation is provided.
7. This product should be operated from the type of power indicated on the marking label. If you are not sure of the type of power available, consult your dealer or local power company.
8. Do not allow anything to rest on the power cord. Do not locate this product where persons will walk on the cord.
9. Never push objects of any kind into this product through cabinet slots as they may touch dangerous voltage points or short out parts that could result in a fire or electric shock. Never spill liquid of any kind on the product.



This device complies with the requirements of the EEC directive 2014/30/EU with regard to “Electromagnetic compatibility” and 2014/35/EU “Low Voltage Directive”.



This device complies with part 15 of the FCC rules. Operation is subject to the following two conditions:

- (1) This device may not cause harmful interference.
- (2) This device must accept any interference received, including interference that may cause undesired operation.

CAUTION ON LITHIUM BATTERIES

There is a danger of explosion if the battery is replaced incorrectly. Replace only with the same or equivalent type recommended by the manufacturer. Discard used batteries according to the manufacturer’s instructions.



Battery Caution

Risk of explosion if battery is replaced by an incorrectly type. Dispose of used battery according to the local disposal instructions.



Safety Caution

Note: To comply with IEC60950-1 Clause 2.5 (limited power sources, L.P.S) related legislation, peripherals shall be 4.7.3.2 “Materials for fire enclosure” compliant.

4.7.3.2 Materials for fire enclosures

For MOVABLE EQUIPMENT having a total mass not exceeding 18kg.the material of a FIRE ENCLOSURE, in the thinnest significant wall thickness used, shall be of V-1 CLASS MATERIAL or shall pass the test of Clause A.2.

For MOVABLE EQUIPMENT having a total mass exceeding 18kg and for all STATIONARY EQUIPMENT, the material of a FIRE ENCLOSURE, in the thinnest significant wall thickness used, shall be of 5VB CLASS MATERIAL or shall pass the test of Clause A.1

LEGISLATION AND WEEE SYMBOL

2012/19/EU Waste Electrical and Electronic Equipment Directive on the treatment, collection, recycling and disposal of electric and electronic devices and their components.

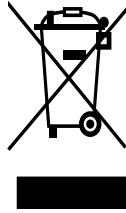

The crossed dust bin symbol on the device means that it should not be disposed of with other household wastes at the end of its working life. Instead, the device should be taken to the waste collection centers for activation of the treatment, collection, recycling and disposal procedure.

To prevent possible harm to the environment or human health from uncontrolled waste disposal, please separate this from other types of wastes and recycle it responsibly to promote the sustainable reuse of material resources.

Household users should contact either the retailer where they purchased this product, or their local government office, for details of where and how they can take this item for environmentally safe recycling.

Business users should contact their supplier and check the terms and conditions of the purchase contract.

This product should not be mixed with other commercial wastes for disposal.

Revision History

Changes to the original user manual are listed below:

Revision	Description	Date
1.0	• Initial release	July, 2017

Table of Contents

1. Packing List	1
1-1. Standard Contents.....	1
1-2. Optional Accessories.....	2
2. System View.....	3
2-2. Front View	3
2-1. Side & Rear View	3
2-3. IO Port View	4
2-4. Dimensions.....	4
3. System Assembly & Disassembly	5
3-1. Open the RearCover.....	5
3-2. Install the Power Adapter.....	6
4. Peripherals Installation	7
4-1. Install the MSR Module	7
4-2. Install the LCM Module.....	8
4-3. Install the 2 nd Display Module	9
4-4. Load the Thermal Printer Paper.....	10

5. Specifications	11
6. Configuration	12
6-1. D33 Motherboard Layout	12
6-2. Connectors & Functions	13
6-3. Jumper Settings	14

The page is intentionally left blank.

1. Packing List

1-1. Standard Contents

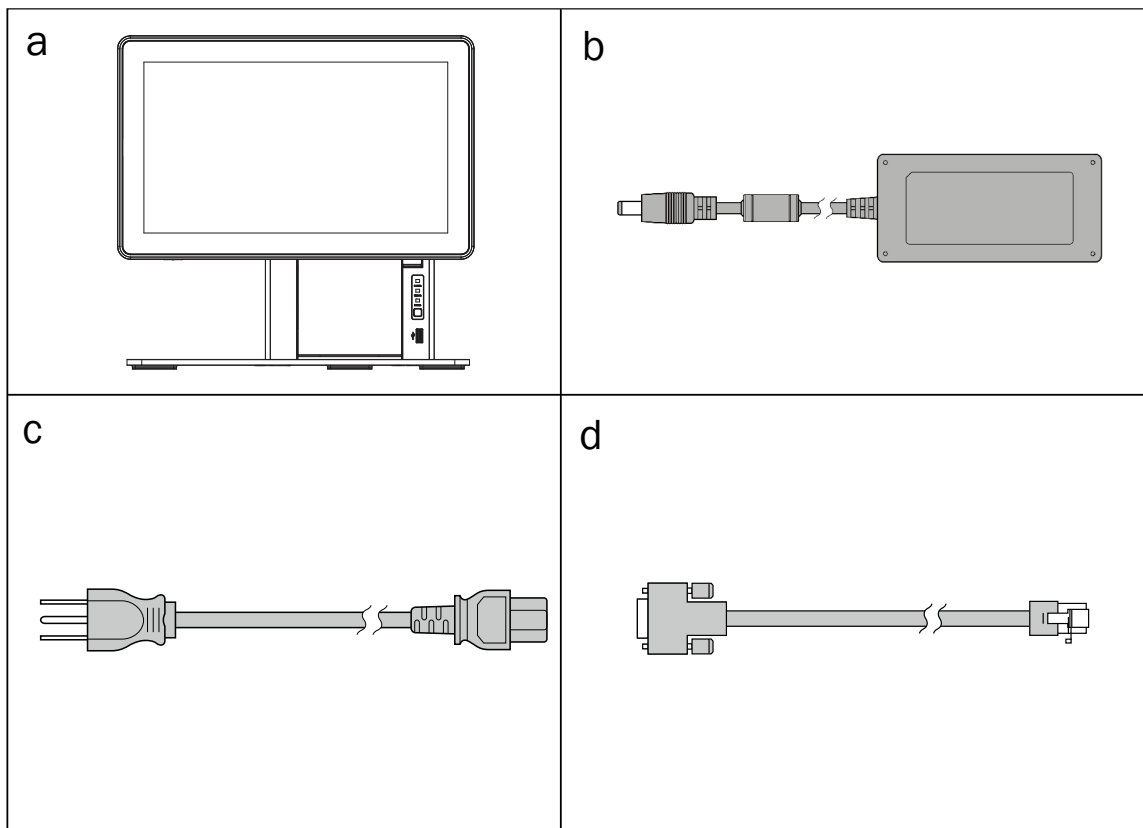

- a. ION TP5 Terminal
- b. Power adapter
- c. Power cord
- d. RJ45-DB9 cable (x1)

1-2. Optional Accessories

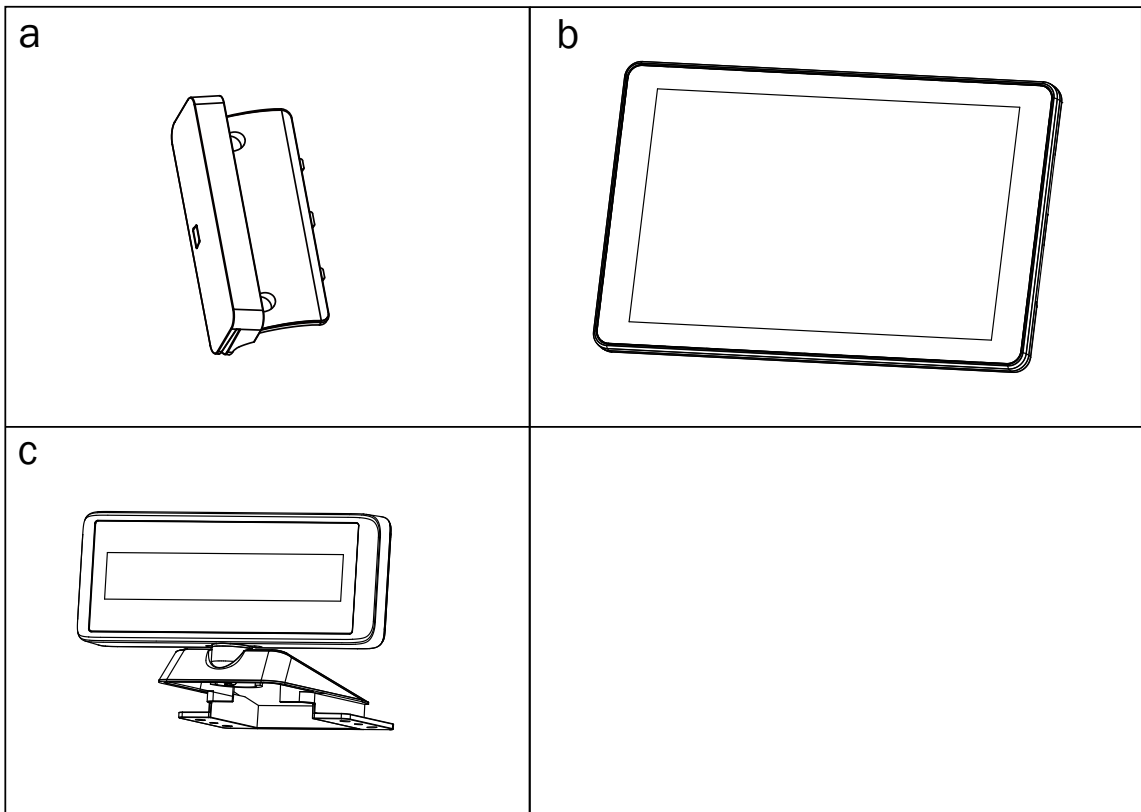

- a. MSR module
- b. 2nd display module
- c. LCM module

2. System View

2-2. Front View

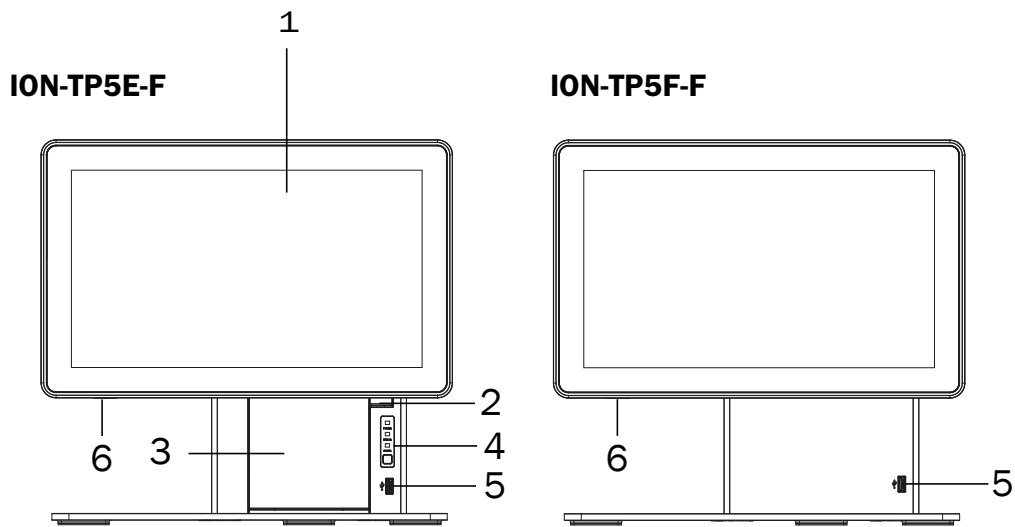

Item No.	Description
1	Touch screen
2	Paper Door Button
3	Thermal printer
4	Printer indicator(power, error, and paper) & Paper feed button
5	Front Facing USB 2.0
6	Power Button

2-1. Side & Rear View

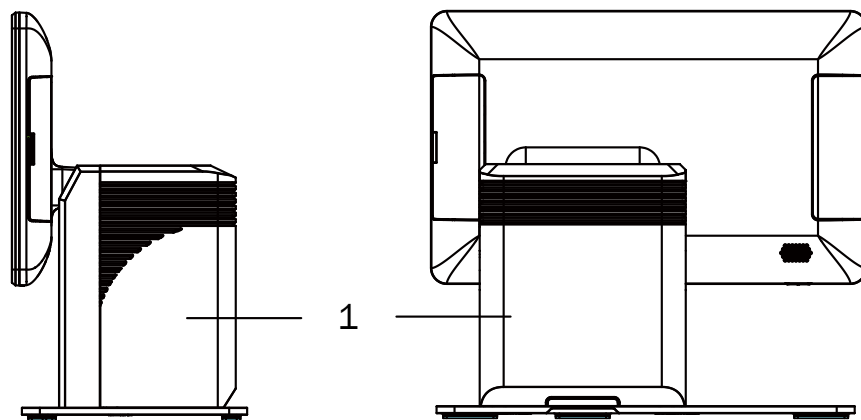

Item No.	Description
1	Back cover (IO board and thermal printer inside)

2-3. IO Port View

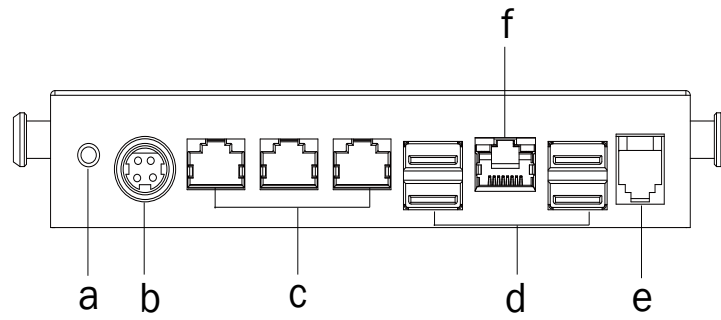

Item No.	Description
a	Power button
b	DC 19V in
c	COM 1~3 (from left to right)
d	USB 2.0 x 4
e	LAN
f	Cash drawer

2-4. Dimensions

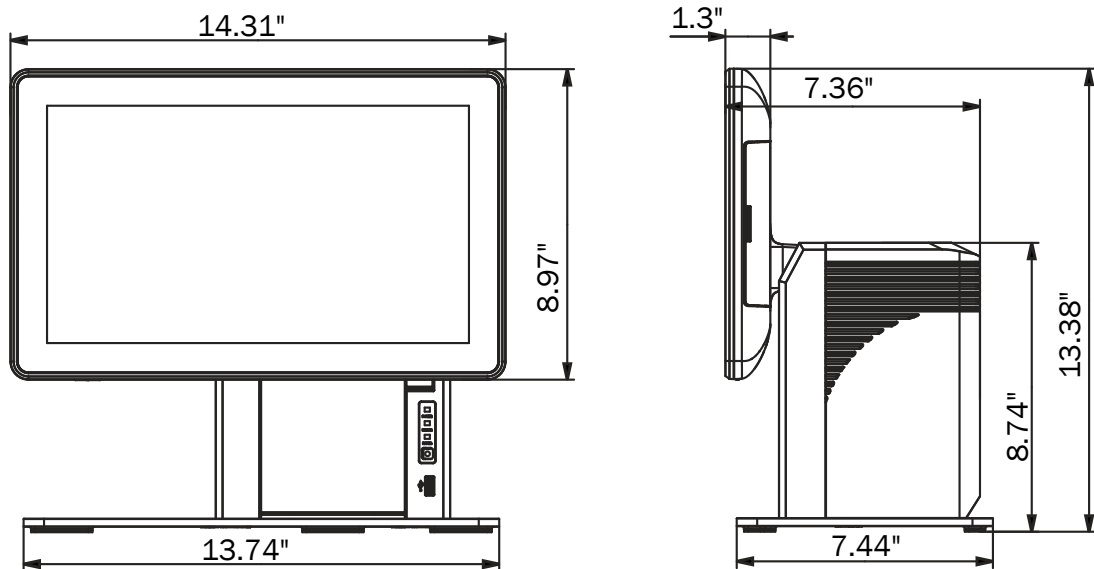

3. System Assembly & Disassembly

3-1. Open the Rear Cover

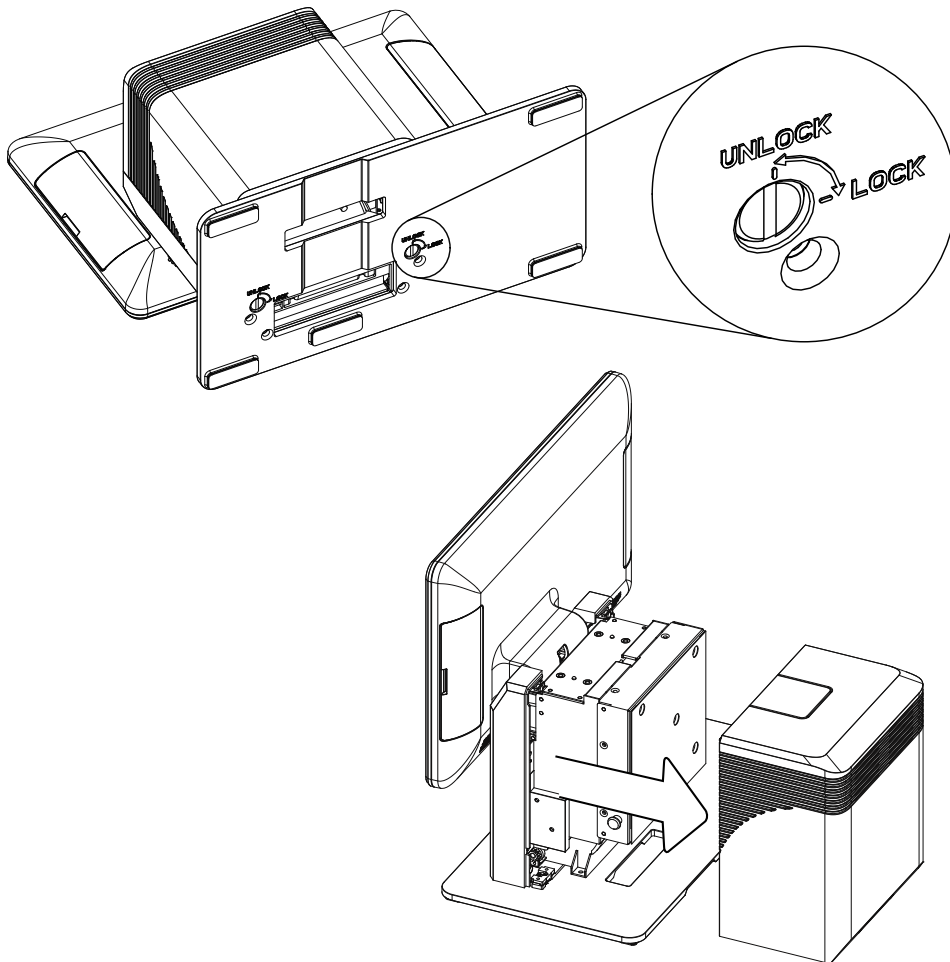

1. The back cover of the system is secured by two bolt screws which are located on the bottom of the base plate.
2. To open the back cover, firstly place the system face down. From there, you will be able to see the bottom of the system.
3. Insert a small coin into the large groove of the screw and turn counterclockwise to unscrew.
4. Use both hands to pull the cover upward to release the rear cover from the system.

3-2. Install the Power Adapter

The system is equipped with a 90W power adapter. Please plug it into the system as shown below.

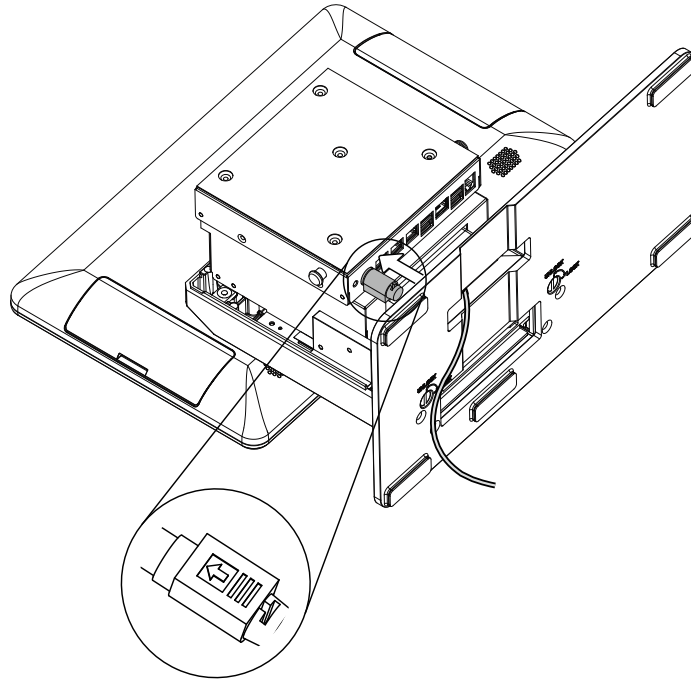

1. Follow the steps described in Chapter 3-1 to open the rear cover first.
2. Place the system face down to access the bottom of the base.
3. Thread the power adapter cable through the hole of the stand as shown in the picture.
4. Find the power connector on the right of the I/O panel (refer to chapter 2-3 b.) and plug the power adapter into the DC-IN connector with the flat side facing the terminal.
5. Finally arrange and secure the cable by as shown in the picture.

Warning:

- Please follow the directions when connecting the adapter and make sure it is fully connected into the I/O port.
- When attaching or detaching the cable, do so by holding the connector, not the cable itself.
- **DO NOT** pull or rotate the cable which may cause damage to the port.

Turn the system on:

1. Located the power button on the bottom left corner of the screen. Hold down the power button for 3 seconds to power on the system.

Turn off the system:

1. Hold down the power button for 5 seconds to bring up the "Slide to shutdown" screen.
 2. To force a hard shut down, hold down the power button for 10 seconds. **WARNING:** This can cause data loss and render the system inoperable.
- * When the power adapter is connected, the power LED on the printer indicator will blink slowly.

4. Peripherals Installation

4-1. Install the MSR Module

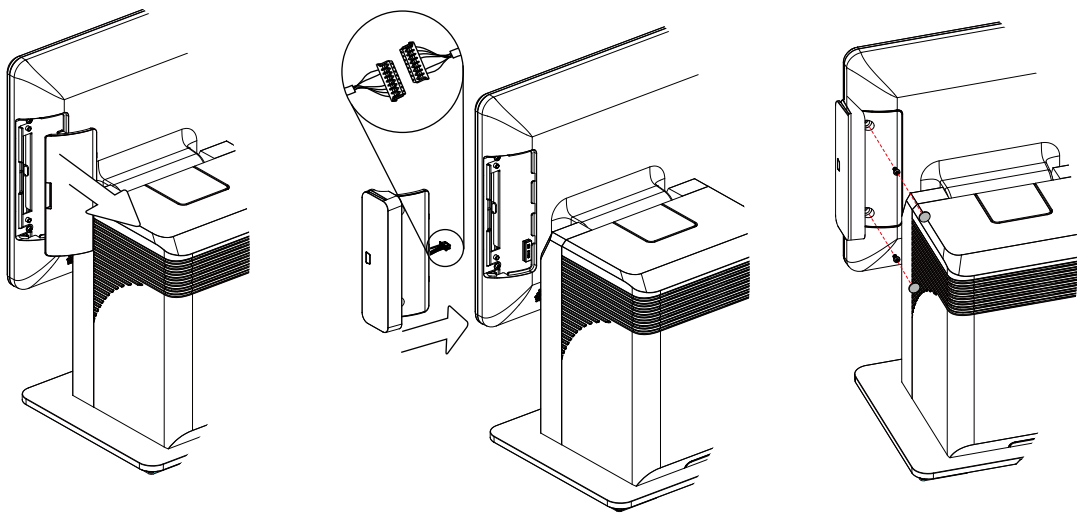

1. Remove the dummy cover first.
2. Connect the MSR cable to the connector on the inside of the system.
3. Insert the MSR module in place and fasten the screws (x2) on the back to secure the module. Do not over tighten the screws to avoid damage to the plastic parts.
4. Finally cover the screws with the rubber covers.

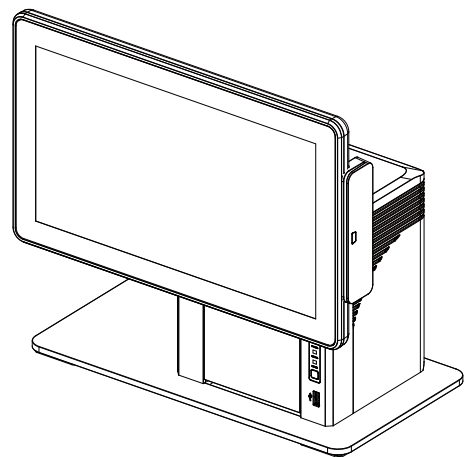

4-2. Install the LCM Module

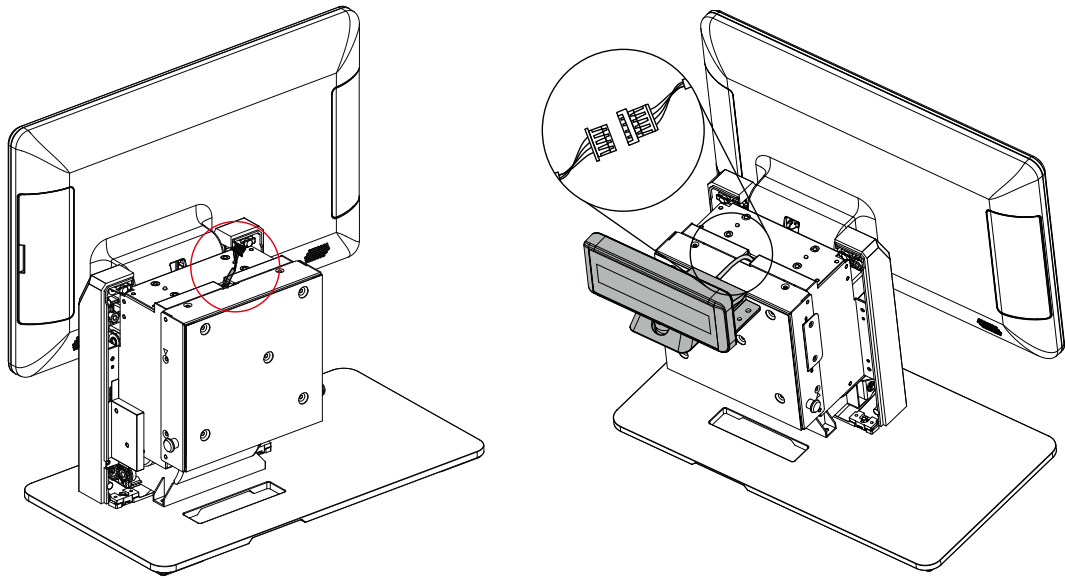

1. Follow the steps described in Chapter 3-1 to open the back cover of the system first.
2. After opening the back cover, you will find the LCM connector located inside. Connect this connector to the other end of the connector of the LCM module.

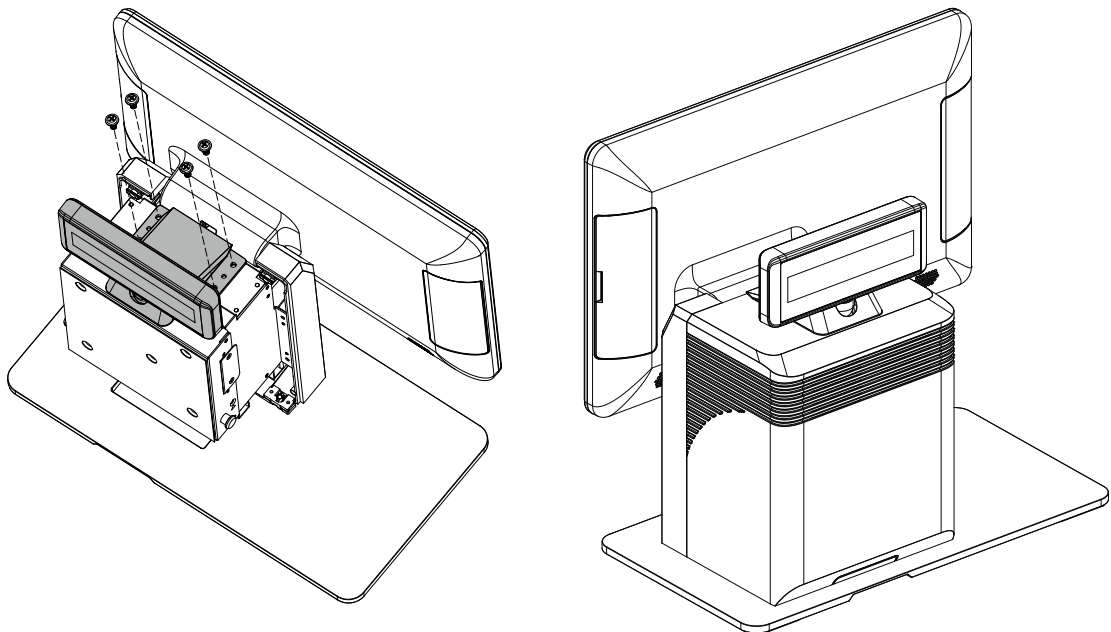

3. Finally, fasten the screws(x4) to secure the LCM module to the system.

4-3. Install the 2nd Display Module

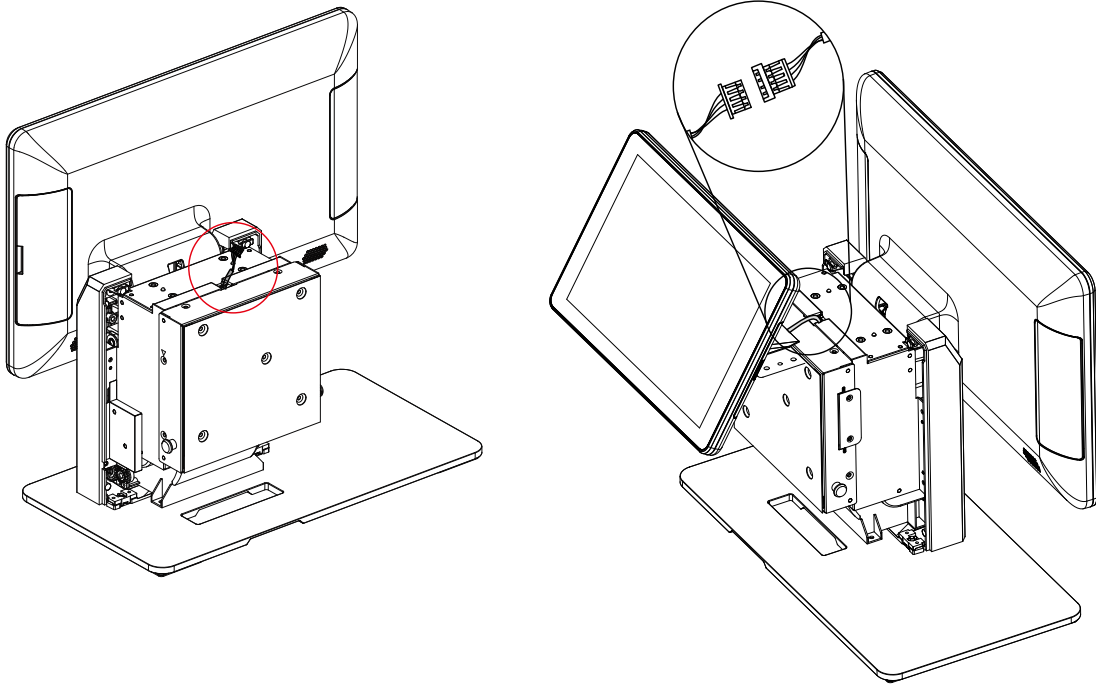

1. Follow the steps described in Chapter 3-1 to open the back cover of the system first.
2. After opening the back cover, you will find the 2nd display connector located inside. Connect this connector to the other end of the connector of the 2nd display module.

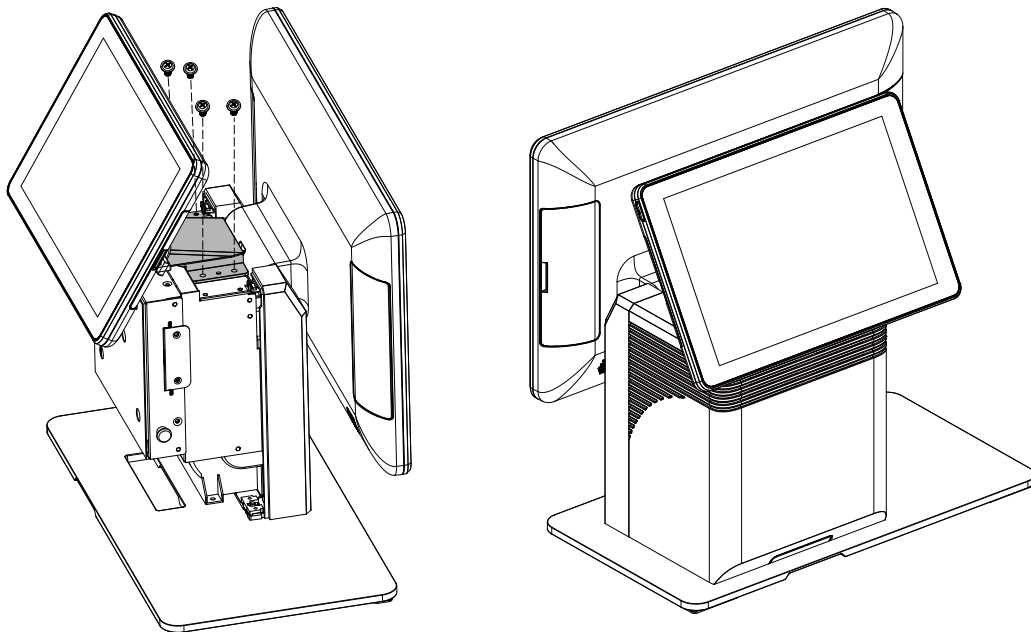

3. Finally, fasten the screws(x4) to secure the 2nd display module to the system.

4-4. Load the Thermal Printer Paper

**Note: Do not switch off the system. The printer must be powered on when replacing the printer paper.
Integrated printer only available in select models**

1. Press the button at the right side to open the thermal printer module.

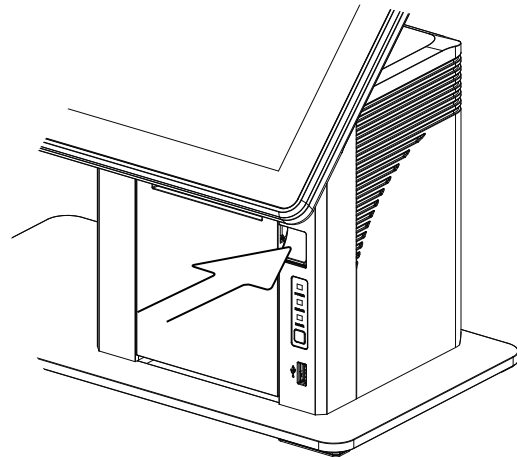

- * Cut away the first two (2) inches of the paper, to obtain a straight edge and remove the label at the end of the roll.

2. Place the paper roll inside the printer slot, pull out 2 or 3 inches of paper and then close the cover.

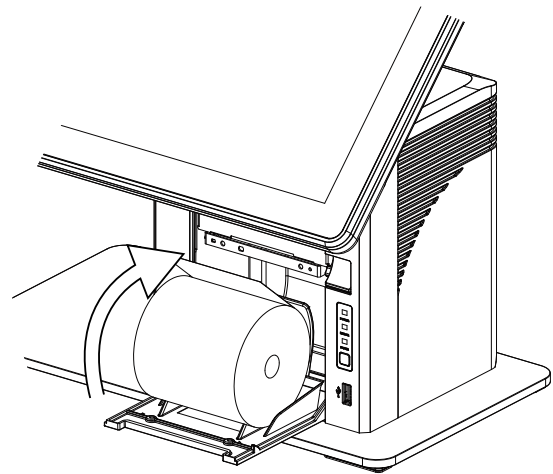

3. The paper will feed automatically through the printer (the system must be powered on).

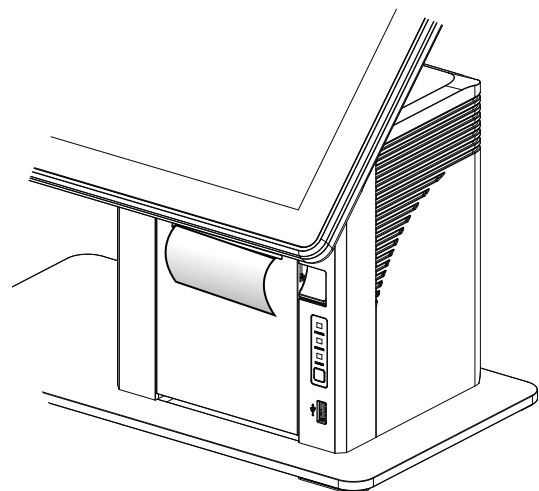

5. Specifications

Model	ION-TP5E-F	ION-TP5F-F
CPU support	Intel Bay Trail CPU Celeron J1900	
System memory	4GB / 8GB DDR3 SO-DIMM	
Storage	32GB / 64GB pSSD	
LCD touch panel		
LCD size	14" TFT LCD (eDP)	
Maximal resolution	1366 x 768	
Brightness	200 nits	
Touch screen type	True Flat P.Cap Touch	
Tilt angle	0°~90° (w/o LCM and 2 nd display)	
Expansion I/O ports		
USB port	4 x USB 3.0 Type-A / 1x USB2.0 USB, front side	
COM port	3 x RJ-48 (COM1 0V/5/12V; COM2 0V/5V/12V; COM3 0V/5V/12V; default BIOS setting 0V)	
Cash drawer	1 x RJ-11 (12V/19V selection by jumper setting, default 19V)	
LAN port	1 x RJ-45 (10/100/1000 Base T)	
DC jack	4 pin w/ lock	
Power		
Power adapter	120W/19V	
Control / Indicator		
Power button	1	
Printer feed button	1	NA
Printer LED Indicator	3 (Paper, Error, Power)	NA
Peripherals		
Built in printer	3" 6.7 inches/sec , Auto cutter, Easy paper change, Out of paper sensor, Paper roll dia. 3.15"	NA
MSR	3 Track MSR (USB)	
Audio		
Built in speaker	2W x 2 (Option)	
Environment		
Sealing	IP54 (Display side)	
EMC & Safety	FCC, Class A, CE, LVD	
ESD	4kV contact discharge, 8kV air discharge	
Operating temperature	32°F ~ 95°F (0°C ~ 35°C)	
Storage temperature	-4°F ~ 140°F (-20°C ~ 60°C)	
Humidity	20% ~ 85% RH non condensing	
Dimension (W x D x H)	LCD 90° tilt angle: 14.3" x 7.5" x 13.4" (363 x 189 x 340 mm)	
Weight (N.W./G.W.)	11.0 lbs (5kg) / 13.2 lbs (6kg)	9.0 lbs (4.1kg) / 11.2 lbs (5.1kg)
OS support*	Windows 7; Windows 8.1; Windows 10; Linux	

* This specification is subject to change without prior notice.

6. Configuration

6-1. D33 Motherboard Layout

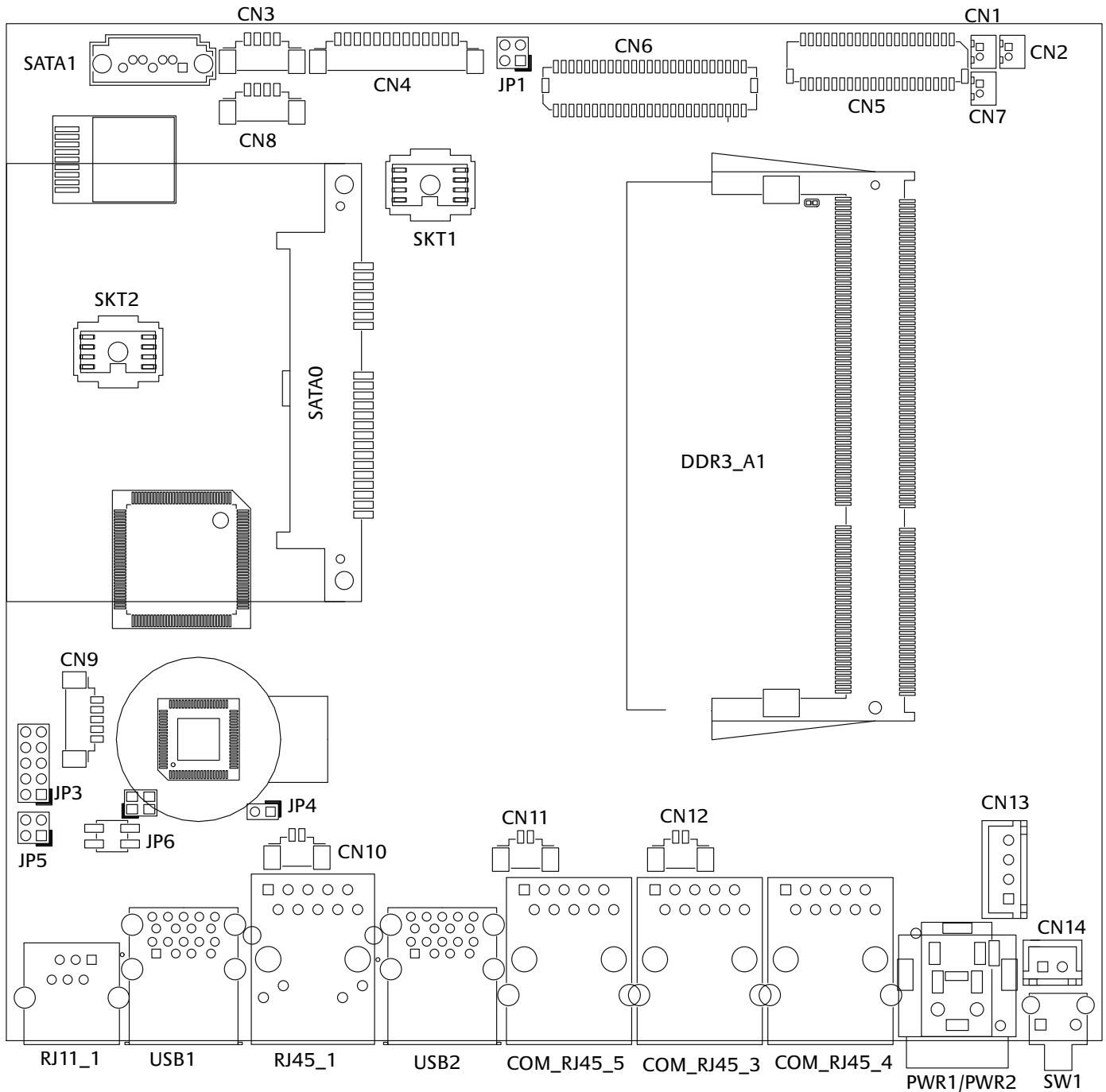

6-2. Connectors & Functions

Connector	Function
CN1	Speaker_L connector
CN2	Speaker_R connector
CN3/CN8	US2.0(internal)
CN4	VGA output(internal)
CN5	24V converter board connector
CN6	50 pin I/O connector(LVDS/Audio/USB/eDP)
CN7	Mic connector
CN9	EC debug connector
CN10	Battery connector
CN11	Power LED
CN12	HDD LED
CN13	SATA power
CN14	Push-pull button connector
COM_RJ45_3	COM3
COM_RJ45_4	COM2
COM_RJ45_5	COM1
RJ45_1	LAN connector
RJ11_1	Cash drawer connector
PWR1/2	DC Jack
SATA0/SATA1	SATA gen2
SW1	Power button
USB1/2	USB3.0
DDR3_A1	DDR3 SO-DIMM
JP1	LVDS eDP Setting
JP2	N/A
JP3	LCD ID setting
JP4	Clear CMOS
JP5	Cash drawer control setting
JP6	Cash drawer power setting

6-3. Jumper Settings

LVDS eDP Setting

Function	JP1				
eDP	<table border="1"> <tr><td>1</td><td>3</td></tr> <tr><td>2</td><td>4</td></tr> </table>	1	3	2	4
1	3				
2	4				
▲ LVDS	<table border="1"> <tr><td>1</td><td>3</td></tr> <tr><td>2</td><td>4</td></tr> </table>	1	3	2	4
1	3				
2	4				

Cash Drawer Contrl Setting

Function	JP5				
Print Board	<table border="1"> <tr><td>1</td><td>3</td></tr> <tr><td>2</td><td>4</td></tr> </table>	1	3	2	4
1	3				
2	4				
▲ M/B	<table border="1"> <tr><td>1</td><td>3</td></tr> <tr><td>2</td><td>4</td></tr> </table>	1	3	2	4
1	3				
2	4				

Cash Drawer Power Setting

Function	JP6				
▲ +19V	<table border="1"> <tr><td>1</td><td>3</td></tr> <tr><td>2</td><td>4</td></tr> </table>	1	3	2	4
1	3				
2	4				
+12V	<table border="1"> <tr><td>1</td><td>3</td></tr> <tr><td>2</td><td>4</td></tr> </table>	1	3	2	4
1	3				
2	4				

▲ = Manufacturer Default Setting

1
2

 Jumper open

1
2

 Jumper short

COM1/COM2/COM3 Power Setting

COM1, COM2 and COM3 can be set to provide power to your serial device. The voltage can be set to +5V or +12V in the BIOS.

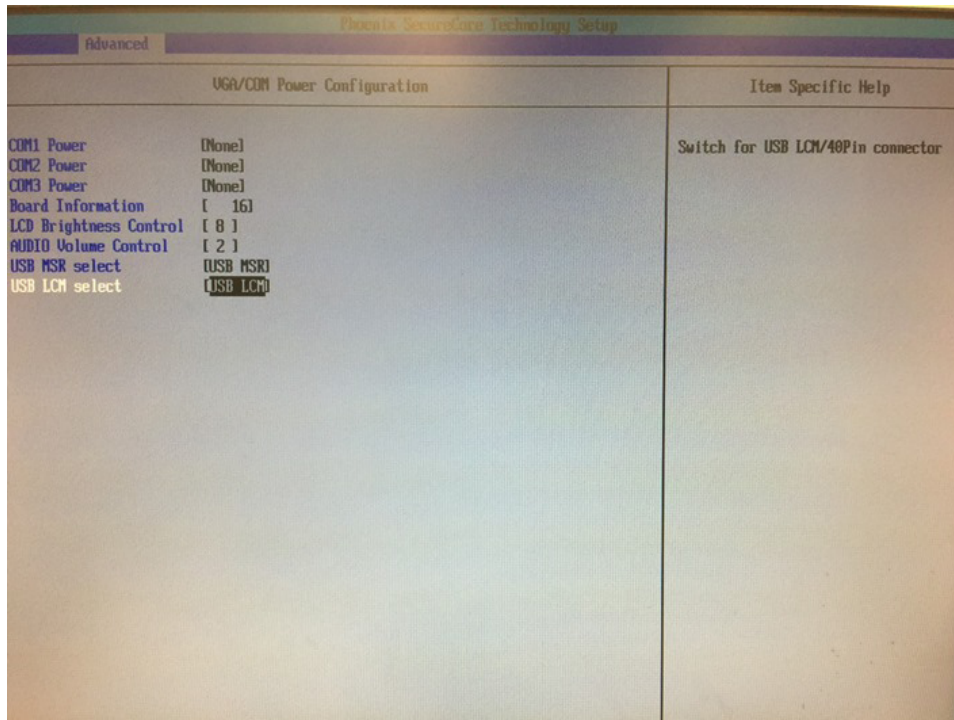

1. Power on the system, and press the key when the system is booting up to enter the BIOS Setup utility.
2. Select the Advanced tab.
3. Select **VGA/COM Power Configuration** Ports and press <Enter> to go to the available options.
4. To enable the power, select COM1 ,COM2 or COM3 Power setting and press <Enter>. Select Power and press <Enter>. Save the change by pressing F10.

LCD ID Setting

Panel#	Resolution	LVDS		Output Interface											
		Bits	Channel												
1	800 x 600	18	Single	LVDS Panel	<table style="display: inline-table; border-collapse: collapse;"> <tr> <td style="border: 1px solid black; padding: 2px;">1</td> <td style="border: 1px solid black; padding: 2px;">3</td> <td style="border: 1px solid black; padding: 2px;">5</td> <td style="border: 1px solid black; padding: 2px;">7</td> <td style="padding: 2px;">9</td> </tr> <tr> <td style="border: 1px solid black; padding: 2px;">2</td> <td style="border: 1px solid black; padding: 2px;">4</td> <td style="border: 1px solid black; padding: 2px;">6</td> <td style="border: 1px solid black; padding: 2px;">8</td> <td style="padding: 2px;">10</td> </tr> </table>	1	3	5	7	9	2	4	6	8	10
1	3	5	7	9											
2	4	6	8	10											
2	800 x 600	24	Single	LVDS Panel	<table style="display: inline-table; border-collapse: collapse;"> <tr> <td style="border: 1px solid black; padding: 2px;">1</td> <td style="padding: 2px;">3</td> <td style="border: 1px solid black; padding: 2px;">5</td> <td style="border: 1px solid black; padding: 2px;">7</td> <td style="padding: 2px;">9</td> </tr> <tr> <td style="border: 1px solid black; padding: 2px;">2</td> <td style="padding: 2px;">4</td> <td style="border: 1px solid black; padding: 2px;">6</td> <td style="border: 1px solid black; padding: 2px;">8</td> <td style="padding: 2px;">10</td> </tr> </table>	1	3	5	7	9	2	4	6	8	10
1	3	5	7	9											
2	4	6	8	10											
3	1024 x 768	18	Single	LVDS Panel	<table style="display: inline-table; border-collapse: collapse;"> <tr> <td style="padding: 2px;">1</td> <td style="padding: 2px;">3</td> <td style="border: 1px solid black; padding: 2px;">5</td> <td style="border: 1px solid black; padding: 2px;">7</td> <td style="padding: 2px;">9</td> </tr> <tr> <td style="padding: 2px;">2</td> <td style="padding: 2px;">4</td> <td style="border: 1px solid black; padding: 2px;">6</td> <td style="border: 1px solid black; padding: 2px;">8</td> <td style="padding: 2px;">10</td> </tr> </table>	1	3	5	7	9	2	4	6	8	10
1	3	5	7	9											
2	4	6	8	10											
4	1024 x 768	24	Single	LVDS Panel	<table style="display: inline-table; border-collapse: collapse;"> <tr> <td style="border: 1px solid black; padding: 2px;">1</td> <td style="border: 1px solid black; padding: 2px;">3</td> <td style="padding: 2px;">5</td> <td style="border: 1px solid black; padding: 2px;">7</td> <td style="padding: 2px;">9</td> </tr> <tr> <td style="border: 1px solid black; padding: 2px;">2</td> <td style="border: 1px solid black; padding: 2px;">4</td> <td style="padding: 2px;">6</td> <td style="border: 1px solid black; padding: 2px;">8</td> <td style="padding: 2px;">10</td> </tr> </table>	1	3	5	7	9	2	4	6	8	10
1	3	5	7	9											
2	4	6	8	10											
▲ 5	1366 x 768	18	Single	LVDS Panel	<table style="display: inline-table; border-collapse: collapse;"> <tr> <td style="padding: 2px;">1</td> <td style="border: 1px solid black; padding: 2px;">3</td> <td style="padding: 2px;">5</td> <td style="border: 1px solid black; padding: 2px;">7</td> <td style="padding: 2px;">9</td> </tr> <tr> <td style="padding: 2px;">2</td> <td style="border: 1px solid black; padding: 2px;">4</td> <td style="padding: 2px;">6</td> <td style="border: 1px solid black; padding: 2px;">8</td> <td style="padding: 2px;">10</td> </tr> </table>	1	3	5	7	9	2	4	6	8	10
1	3	5	7	9											
2	4	6	8	10											

▲ = Manufacturer Default Setting

1	Jumper open	1	Jumper short
2	Jumper open	2	Jumper short