

**ML620/ML621**

## **User's Guide**

ML620/ML621 User's Guide

P/N 59320101, Revision 1.2

September, 2010

Every effort has been made to ensure that the information in this document is complete, accurate, and up-to-date. Oki Data assumes no responsibility for the results of errors beyond its control. Oki Data also cannot guarantee that changes in software and equipment made by other manufacturers and referred to in this guide will not affect the applicability of the information in it. Mention of software products manufactured by other companies does not necessarily constitute endorsement by Oki Data.

Copyright 2010 by Oki Data. All rights reserved.

## Trademark Information

OKI and MICROLINE are registered trademarks of Oki Electric Industry Company, Ltd.

Epson is a registered trademark of Epson America, In.

IBM is a registered trademark of International Business Machines Corp.

Microsoft and Windows are either registered trademarks or trademarks of Microsoft Corporation in the United States and other countries.

<b>Chapter 1: Introduction</b> .....	<b>5</b>
<b>Printer Features</b> .....	<b>5</b>
Oki Data on the Internet.....	5
<b>Parts Identification: Front View</b> .....	<b>6</b>
<b>Parts Identification: Rear View</b> .....	<b>7</b>
<b>Parts Identification: Inside View</b> .....	<b>7</b>
<b>The Control Panel</b> .....	<b>8</b>
Print Mode Key Functions.....	12
<b>Chapter 2: Paper Handling</b> .....	<b>14</b>
<b>Loading Continuous Forms Paper</b> .....	<b>15</b>
Rear Feed.....	16
Front Feed .....	19
Bottom Feed (optional pull tractor) .....	21
Tearing Off Continuous Forms Paper .....	22
Aligning the Tear-Off Perforations .....	22
Removing Continuous Forms Paper.....	22
<b>Loading Cut Sheet Paper</b> .....	<b>23</b>
Cut Sheet Paper, Top and Front Feed .....	23
Ejecting Cut Sheet Paper .....	25
Notes on Different Types of Paper .....	25
<b>Top of Form (TOF)</b> .....	<b>26</b>
Top of Form (TOF) and Forms Tear-Off .....	26
Determining if Forms Tear-Off is Off or On.....	27
To print the Menu:.....	27
To use the TEAR key:.....	27
Setting Top of Form (TOF): .....	28
Temporarily Changing the Top of Form Position .....	29
Resetting Top of Form to the Factory Default.....	29
<b>Forms Tear-Off Feature</b> .....	<b>30</b>

Potential Problems with Software Packages .....	30
Changing the Forms Tear-Off Setting.....	31
Manual Forms Tear Off.....	31
<b>Paper Park</b> .....	<b>32</b>
<b>Setting the Paper Thickness Lever</b> .....	<b>32</b>
Paper Type Table .....	33
<b>Chapter 3: Print Settings</b> .....	<b>34</b>
<b>Print Quality</b> .....	<b>35</b>
Draft: Utility—the default .....	35
HSD: High Speed Draft.....	35
SSD: Super Speed Draft.....	35
NLQ: Near Letter Quality .....	35
<b>Character Pitch</b> .....	<b>36</b>
<b>Print Speed</b> .....	<b>37</b>
<b>Printer Reset</b> .....	<b>37</b>
<b>Emulations</b> .....	<b>38</b>
Changing Emulations.....	38
<b>Chapter 4: Menu Mode</b> .....	<b>39</b>
Menu Mode Keys.....	39
Menu Mode Keys and Functions .....	40
Entering and Exiting Menu Mode.....	41
Resetting the Menu to the Factory Defaults .....	41
Printing the Menu Settings.....	42
Printing the Current Menu Settings.....	42
Printing All Menu Settings.....	42
Changing the Menu Settings .....	42
Menu Settings Table.....	43

<b>Chapter 5: Maintenance</b> .....	<b>69</b>
<b>Replacing the Ribbon Cartridge</b> .....	<b>69</b>
Ribbon Cartridge Handling .....	69
If ribbon should contact the eyes: .....	72
If ribbon should contact the skin .....	72
For more information .....	72
<b>Clearing Paper Jams</b> .....	<b>72</b>
Continuous Feed Paper Jams .....	72
Cut Sheet Paper Jams .....	74
<b>Cleaning the Printer</b> .....	<b>75</b>
Printer Exterior .....	75
Printer Interior .....	76
<b>Testing the Printer</b> .....	<b>77</b>
Font Sample Test .....	77
Rolling ASCII Test .....	78
Hexadecimal Dump Mode .....	79
<b>Chapter 6: Troubleshooting</b> .....	<b>80</b>
<b>General Information</b> .....	<b>80</b>
<b>Responding to Alarm Conditions</b> .....	<b>81</b>
<b>Problems/Solutions</b> .....	<b>82</b>
<b>Appendix A: Parts &amp; Accessories</b> .....	<b>88</b>
<b>Purchasing Parts &amp; Accessories</b> .....	<b>88</b>
<b>Consumables</b> .....	<b>89</b>
<b>Accessories</b> .....	<b>89</b>
<b>Appendix B: Printer Control Codes</b> .....	<b>90</b>
<b>IBM Proprinter III Commands</b> .....	<b>90</b>
<b>Epson FX Commands</b> .....	<b>93</b>
<b>Oki MICROLINE Standard Commands</b> .....	<b>95</b>

<b>Appendix C: Specifications</b> .....	<b>97</b>
Print Method .....	97
Printhead .....	97
Interfaces .....	97
Receive Buffer Size .....	97
Printhead Life .....	97
Reliability .....	97
Ribbon Life .....	97
Emulations (co-resident) .....	97
Physical Specifications .....	97
ML620 .....	97
ML621 .....	97
Print Speed .....	98
Characters per Line (cpl) .....	98
Graphics Resolution .....	98
Resident Fonts .....	98
Bar Codes .....	99
Paper Thickness: Tractor Feed .....	99
Environmental Requirements .....	99
Temperature .....	99
Humidity .....	99
Electrical Requirements .....	99
Paper Specifications .....	100

# Chapter 1: Introduction

## Printer Features

- Super reliable, durable operation: 25,000 hours Mean Time Between Failures (MTBF) at 25% duty cycle and 35% page density
- Advanced paper handling, with built-in rear push tractor and zero-tear forms capability.
- Blazing print speeds, in characters per second:
  - **High Speed Draft (HSD) Mode:** 600 cps
  - **Utility (Draft) Mode:** 450 cps
  - **Near Letter Quality (NLQ) Mode:** 113 cps
  - **Super Speed Draft (SSD) Mode:** 700 cps (12 CPI only)
- This rugged dual-9-pin printer can meet the needs of harsh and demanding environments.
- Five methods of loading paper and printing: Continuous Forms Rear Feed (Push), Continuous Forms Front Feed (Push), Continuous Forms Bottom Feed (Pull), Cut Sheet (Top), Cut Sheet (Front)

## Oki Data on the Internet

The Oki Data Web Sites provide the most current information available on your printer.

On-line documents are available for viewing and downloading via Oki Data's Web Sites.

You may reach Oki Data via the Internet at:

- [www.okiprintingsolutions.com](http://www.okiprintingsolutions.com)
- [my.okidata.com](http://my.okidata.com)

## Parts Identification: Front View

1. Sheet Guide, Rear
2. Paper Type Lever
3. Platen Knob
4. Sheet Guide, Front (open to fit the front feed paper tray or the tractor)
5. Control Panel
6. On-Off Switch
7. Access Cover

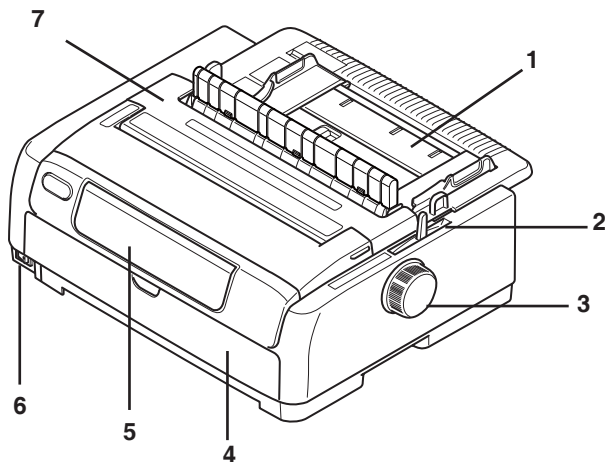

## Parts Identification: Rear View

1. USB connector
2. Parallel connector
3. Optional Serial/Network connector
4. Ventilation
5. Power Connector
6. Optional Cut Sheet Feeder/Roll Paper Stand connector

*Note: The serial number of your printer is on a label on the back, beside "S/N."*

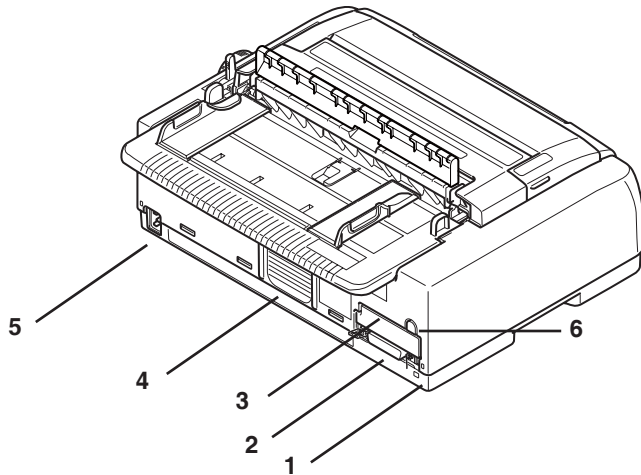

## Parts Identification: Inside View

1. Paper Thickness Lever
2. Ribbon Cartridge
3. Print Head
4. Pull-up Guide Assembly

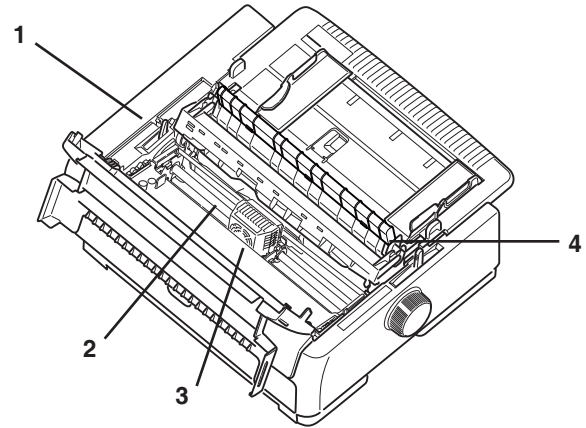

# The Control Panel

The ALARM light indicates an alarm condition

The SEL light indicates if the printer is online

The 7 keys function differently, depending on which printer mode is active

The lights above these key labels show which option in the list is active. For example, if both of the CHR PITCH lights are lit, then 15 CPI is the current character pitch; if both lights are flashing, then PROP (proportional) is the current pitch.

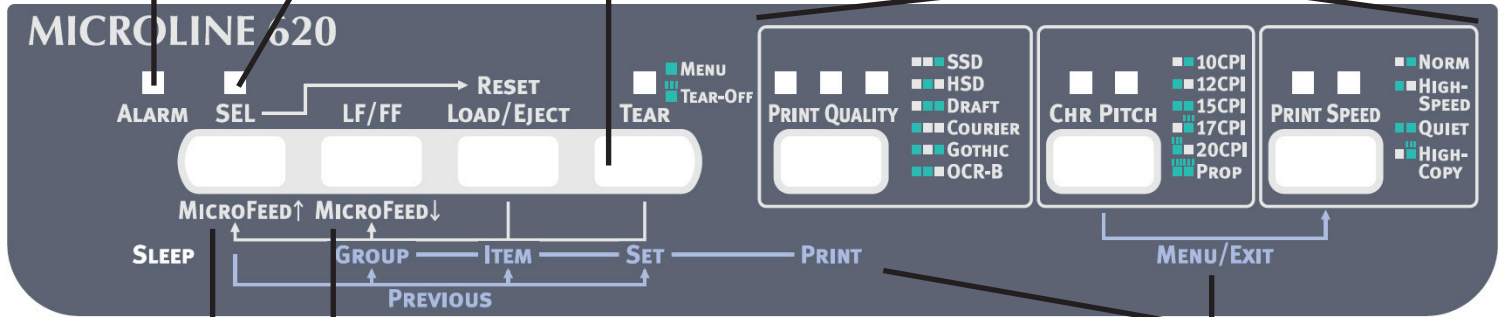

The MICROFEED keys advance (↓) or retract (↑) the paper in small increments

Hold down the CHR PITCH key and press the PRINT SPEED key to enter *Menu* mode; repeat the sequence to exit Menu mode. In Menu mode use the purple text labels underneath the keys to identify the function of each key.

Keys work differently according to which "mode" is active.



The lines above the square indicate a flashing light



### **Control Panel Indicator Light Functions**

<i>Indicator Light</i>	<i>Color</i>	<i>Status</i>	<i>Explanation</i>
<b>ALARM</b>	Red	ON	The paper is at its end; i.e., no paper present.
		OFF	Paper is present.
		Flashing	When flashing with <b>SEL</b> : unrecoverable status alarm. Turn the power OFF, verify that the carriage moves properly, then turn power ON again. May indicate: a paper jam, media alarm, thermal alarm (head/space/feed)  When flashing together with the <b>TEAR</b> light, indicates high temperature alarm status.
<b>SEL</b> (Select)	Green	ON	Printer is online; ready to receive data and print.
		OFF	Printer is offline; not ready to receive data and print.
		Flashing	When flashing with <b>ALARM</b> : unrecoverable status alarm. Turn the power OFF, verify that the carriage moves properly, then turn power ON again.  When flashing together with the <b>TEAR</b> light, indicates the Top Cover is open.
<b>TEAR</b>	Green	ON	Printer is in Menu mode.
		OFF	Printer is in Tear down position.
		Flashing	Printer is in Tear up position.

**Control Panel Indicator Light Functions**

<i>Indicator Light</i>	<i>Color</i>	<i>Status</i>	<i>Explanation</i>
<b>PRINT QUALITY</b>	Green	ON > LED 1 > LED 2 > LED 1 and 2	With <b>ALARM</b> light flashing: > Indicates paper park/eject jam. > Indicates paper loading jam. > Indicates incorrect media setting.
		ON > LED 3 > LED 2 > LED 2 and 3 > LED 1 > LED 1 and 3 > LED 1 and 2	> Indicates SSD is selected. > Indicates HSD is selected. > Indicates DRAFT is selected. > Indicates COURIER is selected. > Indicates GOTHIC is selected. > Indicates OCR-B is selected.
		Flashing > LED 2	With <b>ALARM</b> light flashing: > Indicates an incorrect Paper Lever setting.

**Control Panel Indicator Light Functions**

<i>Indicator Light</i>	<i>Color</i>	<i>Status</i>	<i>Explanation</i>
<b>CHR PITCH</b>	Green	ON > LED 2	With <b>TEAR</b> light ON: > Printer is in <b>Menu Mode</b> .
		ON > LED 2 > LED 1 > LED 1 and 2	Without <b>ALARM</b> light flashing: > 10 CPI is selected. > 12 CPI is selected. > 15 CPI is selected.
		Flashing > LED 2 > LED 1 > LED 1 and 2	Without <b>ALARM</b> light flashing: > 17 CPI is selected. > 20 CPI is selected. > PROP (Proportional) is selected.
<b>PRINT SPEED</b>	Green	ON > LED 2 > LED 1 > LED 1 and 2	With <b>TEAR</b> light OFF: > NORM (Normal Speed) is selected. > HIGH SPEED is selected. > QUIET print is selected.
		Flashing > LED 2	> HIGH COPY is selected.
<b>SLEEP</b>	Green	Flashing	Low power consumption mode.

## Print Mode Key Functions

<b>Function of Keys in PRINT MODE</b>		
<b>Key</b>	<b>Status</b>	<b>Function when pressed</b>
<b>SEL</b>	On-line	Takes the printer off-line.
	Off-line	Takes the printer on-line.
<b>LF/FF</b> (Line Feed/ Form Feed)	On-line	For continuous forms: when paper is loaded, performs a form feed. For cut sheets: to eject the cut sheet hold the button down.
	Off-line	For a line feed: press once For a form feed: press and hold (for more than 400 ms)
<b>LOAD/EJECT</b>	On-line / Off-line	When no paper loaded: performs a paper load. When paper is loaded: - Continuous forms: Retracts the form to the Pin Tractor (i.e., reverses and moves paper out of the printer). - Cut sheet paper: Ejects the cut sheet. - Pull feed: no effect.
	On-line / Off-line	Continuous forms only: moves the paper to its cut position. Pull feed: no effect.
<b>PRINT QUALITY</b>	On-line / Off-line	Press the key to toggle through the font options.
<b>CHR PITCH</b>	On-line / Off-line	Press the key to toggle through the character pitch options.
<b>PRINT SPEED</b>	On-line / Off-line	Press the key to toggle through the print speed options.
<b>SEL + LF/FF</b>	On-line / Off-line	No effect.

**Function of Keys in PRINT MODE**

<b>Key</b>	<b>Status</b>	<b>Function when pressed</b>
<b>SEL + LOAD/ EJECT</b>	On-line	No effect.
	Off-line	Pressing these keys at the same time <b>RESETS</b> the printer to the original factory defaults.
<b>SEL + CHR PITCH</b>	On-line	No effect.
	Off-line	Selects a Menu configuration.
<b>LOAD/EJECT + SEL</b>	On-line / Off-line	Performs a forward line feed of 1/144" when paper is loaded.
<b>LOAD/EJECT + LF/FF</b>	On-line / Off-line	Performs a reverse line feed of 1/144" when paper is loaded.
<b>TEAR + SEL</b>	On-line / Off-line	Performs a forward line feed of 1/144" when paper is in the tear position.
<b>TEAR + LF/FF</b>	On-line / Off-line	Performs a reverse line feed of 1/144" when paper is in the tear position.
<b>CHR PITCH + PRINT SPEED</b>	Online / Offline	Enters/Exits Menu Mode.

## Chapter 2: Paper Handling

This chapter describes how to use continuous forms and cut sheet paper in the printer, including:

- Loading Continuous Forms Paper
  - Rear Feed
  - Front Feed
  - Bottom Feed (optional pull tractor)
- Managing Continuous Forms Paper
  - Tearing Off Continuous Forms Paper
  - Aligning the Tear-Off Perforations
  - Removing Continuous Forms Paper
- Loading Cut Sheet Paper
  - Cut Sheet Paper, Top and Front Feed
- Ejecting Cut Sheet Paper
- Notes on Different Types of Paper

## Loading Continuous Forms Paper

To avoid paper feeding problems:

- Make sure the printer is on a surface approximately 30" (76 cm) above the floor.
- Position the continuous forms supply directly below the printer, no more than 1.2" (3 cm) left or right of the printer paper path.
- Make sure the rear of the printer is close to and parallel with the edge of the surface and at least 24" (61 cm) from any wall.

There are three ways to load continuous forms paper. See the following pages for instructions.

- Rear feed

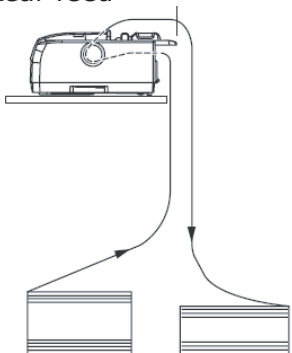

- Front feed

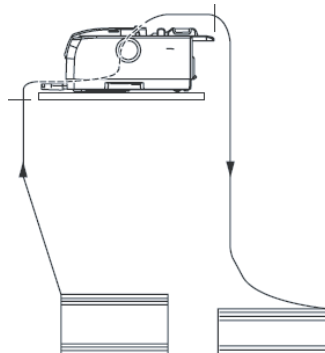

- Bottom feed (optional pull tractor)

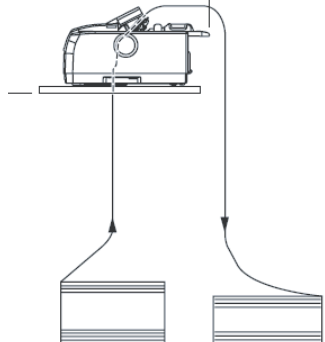

## Rear Feed

*Note: If you have any paper in the paper path, remove it before installing rear feed paper.*

- 1 Lock Lever
- 2 Upper Tractor Cover
- 3 Pins

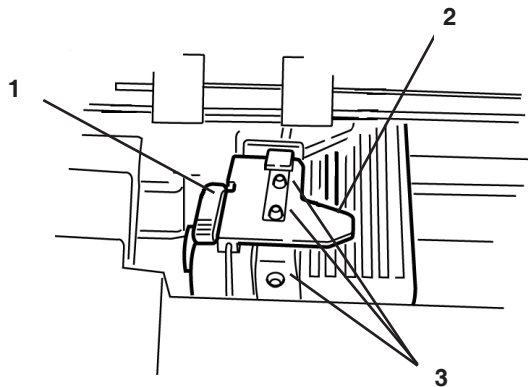

*Note: These instructions assume you have ready access to the back of the printer. If you do not, skip down to "Front Feed."*

1. Make sure the printer is turned ON.
2. Make sure the Paper Type lever is in the REAR feed position:



3. Open the access cover (1) and set the Paper Thickness lever to suit the paper. Close the cover.

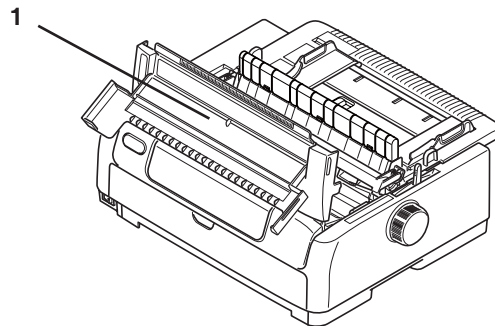



4. Grasp the sheet guide (1). Lift it slightly, then slide it off the printer.

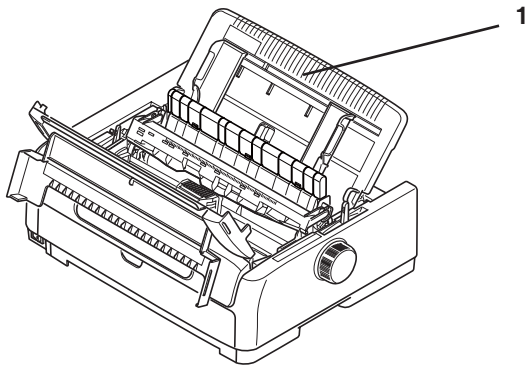

5. From the back of the printer, locate the tractors (1).

NOTE: If the tractor assembly is in the front of the printer, open the front access door, grab the finger guides (2) on each side and pinch them together to release the guide. Remove it from the front and insert it into the back feed and when it is seated, push down to snap the guides in place. Close the front access door.

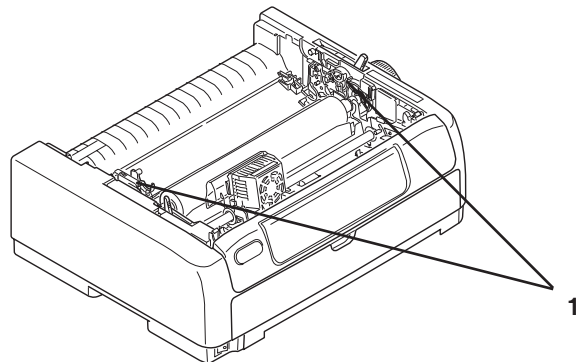
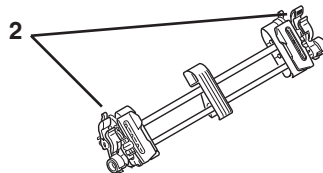

6. Open the lock levers (1) and move the right tractor (**as viewed from the back of the printer**) to the reference mark (2) matching the width of the paper you are loading. Then close the lock lever on the right tractor.

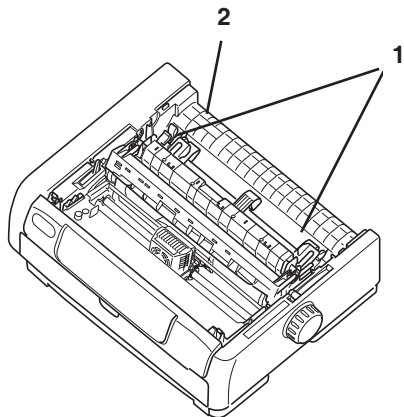

7. Move the rear paper guide to midway between the left and right tractor pins.
8. Open the tractor covers.
9. Place continuous forms paper on the first two pins of either tractor.

### **Important!**

*You must keep the number of paper holes engaged on either pin the same. If you don't the paper will skew and jam.*

10. Close the right tractor cover.
11. Adjust the left tractor until the holes in the paper are centered on the pins then lock the lever and close the left tractor cover.

*Note: If the paper is too loose or too tight it can cause jams.*

12. Lower the top paper tray and slide it towards the front of the printer until the marks align.
13. Press and hold the **LOAD/EJECT** key to advance the paper.

*Note: The factory default setting for the Top of Form (where the printing should begin) is 11/12" (23.28 mm) down from the top of the page. To change the setting, see "Top of Form (TOF)".*

## Front Feed

- 1 Lock Lever
- 2 Upper Tractor Cover
- 3 Pins

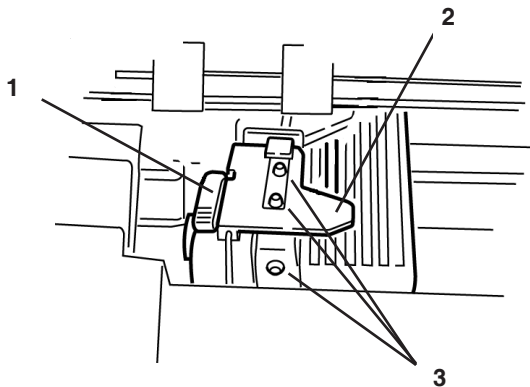

1. Make sure the Paper Type lever is in the FRONT feed position.



2. Pull down the door to open the front sheet guide (1).

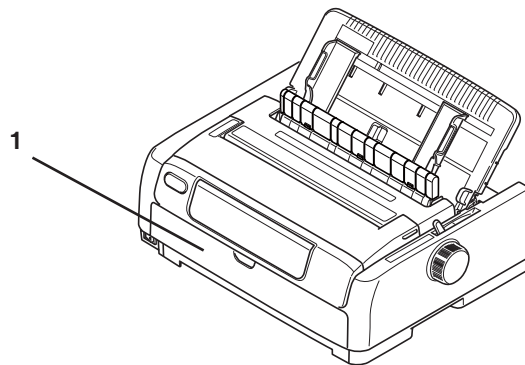

3. Make sure the tractor assembly is in the front of the printer. If the tractor is in the back, remove the sheet guide, grab the finger guides (1) on each side and pinch them together to release the guide. Remove it from the back and insert it into the front feed and when it is seated, push down to snap the guides in place. Replace the back sheet guide.

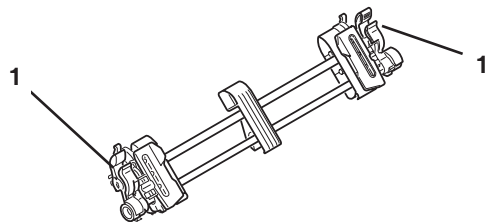

4. Pull up on the lock levers to release them.
5. You will find reference marks on the printer for the most common paper sizes.
6. Move the left tractor to the position to match your paper size and push back on the lever to lock it in place, then move the right tractor to fit the width of the paper.
7. Open the tractor covers and place continuous forms paper on the first two pins of either tractor, then close the *left* tractor cover.

### **Important!**

*You must keep the number of paper holes engaged on either pin the same. If you don't the paper will skew and jam.*

8. Adjust the position of the right tractor to center the holes in the paper on the pins. Then, close the tractor cover and push back the lock lever. Do not stretch the paper.

*Note: If the paper is too loose or too tight it can cause jams.*

9. Press and hold the **LOAD/EJECT** key to advance the paper.

*Note: The factory default setting for the Top of Form (where the printing should begin) is 11/12" (23.28 mm) down from the top of the page. To change the setting, see "Top of Form (TOF)".*

## Bottom Feed (optional pull tractor)

1. Make sure the printer is turned OFF.
2. Remove the access cover.
3. Adjust the Paper Thickness Lever to suit the paper.
4. Make sure the Paper Type Lever is in the PULL position.



5. Place the printer on a slotted printer stand, carefully aligning the slot in the stand with the slot in the base of the printer.
6. Place the paper through the slot in the base of the printer.
7. Bring the paper through the slot in the base of the printer.
8. Lift the locking lever of the left Pin Tractor and slide the Pin Tractor as required to adjust the paper position. Then press the locking lever back down to lock the Pin Tractor.
9. Lift the locking lever of the right pin tractor and slide the Pin Tractor to the required position to

accommodate the width of the continuous forms to be used. Move the paper guide to midway between the left and right Pin Tractors.

10. Open the left and right Pin Tractor covers and feed the continuous forms in the direction of the arrow, locating the sprocket holes in the forms onto the sprocket pins.

*NOTE: Make sure that paper is fed straight into the printer to avoid the possibility of skew printing, irregular line feeding and paper jam.*

11. Make sure that the forms are properly aligned on the sprocket pins, then close the Pin Tractor covers. Adjust the right Pin Tractor to accommodate the width of the continuous forms, taking care that the forms are held neither too loosely nor too tightly between the Pin Tractors. Press the locking lever down to lock the right Pin Tractor in the desired position.

*NOTE: Make sure that the continuous form is pulled down to take up slack. Slack will cause the line spacing to be inconsistent. Turn the platen to help remove the slack.*

11. Close the access cover.
12. Turn the printer ON.
13. Press the **LF/FF** key to feed paper to the tractor.

*NOTE: If the TOF position shifts because of taking up slack, press the LF/FF key to set the TOF position. Do not use the platen knob for this option as this will cause irregular line spacing.*

## Tearing Off Continuous Forms Paper

1. With the **SEL** indicator illuminated, press the **TEAR** key to feed the continuous forms to the tear-off position.
2. Carefully tear off the forms along the tear-off perforations in the direction shown.
3. When data is received by the printer or when the **SEL** key is pressed to select the printer, the continuous forms is repositioned to the first line print position.

## Aligning the Tear-Off Perforations

If the tear-off perforations are not aligned with the paper cutter on the access cover align them as follows:

1. With the **SEL** indicator illuminated, press the **TEAR** button to move the tear-off perforations to the paper cutter on the access cover.
2. Check the position of the tear-off perforations relative to the paper cutter. Adjust to the desired

tear-off position using the 1/144" line feeds (LF).  
- To move the form forward, press and hold the **TEAR** and **SEL** keys at the same time.  
- To move the form backward, press and hold the **TEAR** and **LF/FF** keys at the same time.

3. When the tear-off perforations have been aligned with the paper cutter, release the keys.

When data is received by the printer or when the **SEL** key is pressed to select the printer, the paper will retract to the new position.

## Removing Continuous Forms Paper

1. Tear off the continuous forms.
2. Press the **LOAD/EJECT** key to move the front edge of the continuous forms backwards to the Pin Tractors.

*NOTE:*

*The printer switches to offline mode. The ALARM indicator illuminates to indicate that there is no paper present. If sprocket holes of the last page of the forms disengage from the sprocket pins, do not attempt to eject the paper to avoid the possibility of a paper jam.*

3. Lift the pin tractor covers and remove the forms.
4. Close the pin tractor covers.

## Loading Cut Sheet Paper

There are two methods of loading single sheets of cut sheet paper, top feed and front feed. See the following pages for instruction.

### Cut Sheet Paper, Top and Front Feed

1. Make sure the printer is turned ON.

*Note: If there is any continuous forms paper in the printer, eject it as described in "Removing Continuous Forms Paper".*

2. Make sure that the Pin Tractor covers are closed to avoid the possibility of paper jams.
3. Place the Paper Type lever in the cut sheet position:



4. To load the cut sheet in the Top Feed Paper tray, raise the top tray.  
To load the cut sheet in the Front Feed Paper tray, open the front cover and install the front paper tray.

5. Set the left margin of the paper by adjusting the appropriate Paper Guides (1) along the scale (2) relative to the start of the printed line marker arrow.

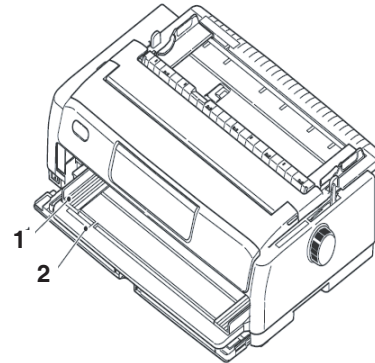
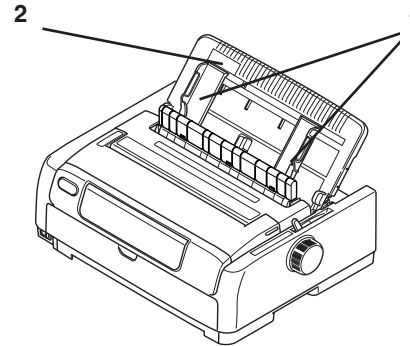

6. Open the access cover and adjust the Paper Thickness lever (1) to suit the paper.

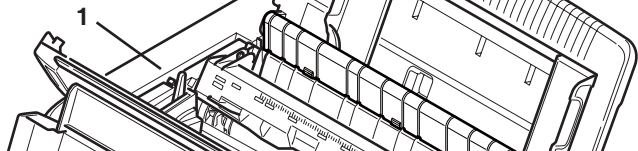

*NOTE: If the Paper Thickness lever setting does not match the paper, feeding and printing may not work properly.*

7. With the printing side downwards for top feed and upwards for front feed and the left edge aligned with the Paper Guide (1), carefully insert the paper on the Paper Tray (2) and into the printer until it is gripped.

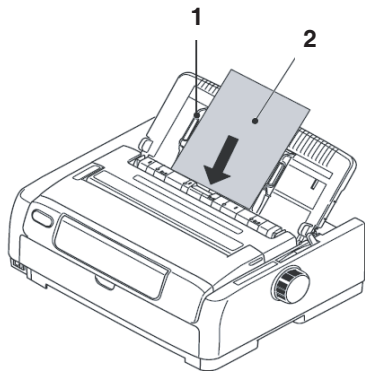

8. To advance the paper in small steps, press LF/FF.

**NOTES:**

- > Make sure that the paper is accurately aligned along the Paper Guide to avoid the possibility of skewed printing or paper jams.
- > When printing an envelope, do not open up the flap.
- > If you are feeding thick paper, push it in sufficiently until it touches the feed roller to avoid the possibility of skewed printing or paper jams.

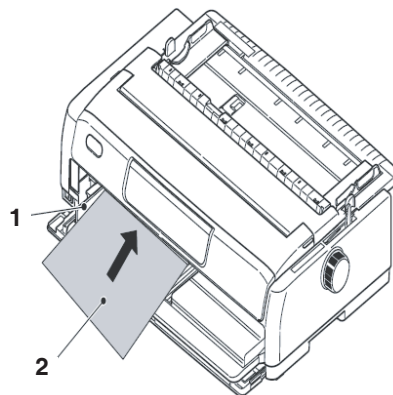



## Ejecting Cut Sheet Paper

When the printer reaches the end of the cut sheet page it automatically ejects the page. If required, add another sheet for the printer to continue printing from where it left off.

To eject a cut sheet left in the printer, follow these steps:

1. Press the **SEL** button to take the printer off-line.
2. Press **LOAD/EJECT** to eject the paper to the paper tray.

## Notes on Different Types of Paper

- **Narrow paper:** When printing on very narrow paper (e.g., three inches), change the Centering position (see the Menu Settings Table in Chapter 3) to "Mode1". Failure to change the Centering position can result in paper jams.
- **Envelopes:** When printing envelopes be sure to adjust the Paper Thickness Lever to include the thickness of the overlapped and glue parts of the envelope — that is, the maximum thickness. If the Paper Thickness Lever is set for the thinnest part of the envelope the print density may fluctuate.
- **Glossy paper:** Test paper with a glossy finish

thoroughly before using. A glossy surface can absorb marks from the paper feed roller or from rubbing. Also, glossy paper may slip causing erratic line spacing.

- **Seal-type cards:** Test seal-type cards thoroughly before using. This type of card can cause ink to transfer.
- **Labels:**
  - Always feed labels from the **FRONT** — **never from the top** — labels fed from the top will peel off, causing paper jams.
  - The adhesive strength of labels can vary — if the adhesive is not strong enough labels can peel off and cause jams.
  - Do not use labels on individual sheets.

## Top of Form (TOF)

### **Important!**

*If you turn the platen knob when the printer is on, the Top of Form misaligns. Always shut the printer off before turning the platen knob.*

*Note: The factory default setting for the Top of Form (where the printing should begin) is 11/12" (23.28 mm) down from the top of the page.*

Top of Form sets the print start position for the printer. It is adjustable in increments of 1/144 of an inch.

The first line prints at the default top of form.

## Top of Form (TOF) and Forms Tear-Off

*Note: Your software may print the first line of print above or below where TOF is set. You may need to adjust the TOF to meet your software's requirements.*

The Top of Form and Forms Tear-Off settings of your printer interact. How you set the Top of Form depends on whether Forms Tear-Off is ON (set to 500 ms, 1 sec, or 2 sec) or OFF (the factory default setting).

## Determining if Forms Tear-Off is Off or On

When the TEAR light is blinking, it indicates that the printer is in TEAR position (i.e., the paper is ready to be torn off).

There are two ways to determine the status of the Forms Tear-Off menu setting:

- Print the Menu
- Use the TEAR key

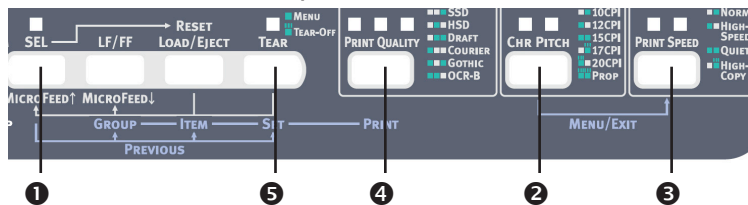

### To print the Menu:

1. Make sure paper is loaded.
2. Press the SEL key (1).
3. Hold down the CHR PITCH (2) key and press the PRINT SPEED key (3).
4. Press the PRINT QUALITY (4) key to print the menu.

5. Look for the Form Tear-Off setting in the paper feed group you are using.

### To use the TEAR key:

1. Make sure paper is loaded.
2. Press TEAR (5).
  - If the paper moves *up*, Forms Tear-off is *off*.
  - If the paper moves *down*, Forms Tear-off is *on*.

## Setting Top of Form (TOF):

### Notes:

*Adjusting the TOF can be done in cut sheet or continuous forms mode.*

*If necessary, print the menu settings to determine where the current TOF is set.*

*The default TOF is set at 11/12" (23.28 mm).*

With paper loaded and the printer on and selected:

1. Align the paper with the first print line position as follows:
  - To set the TOF *lower* (the first line of print on the page moves down), press and hold down the **LOAD/EJECT** and **SEL** keys at the same time.
  - To set the TOF *higher* (the first line of print on the page moves up), press and hold down the **LOAD/EJECT** and **LF/FF** keys at the same time. The paper moves in increments of 1/144".
2. When you have the TOF set where you want it, press and hold **SEL**, then press **LF/FF** to save the new setting.

*Note: To reset the Top of Form to the factory default, see "Resetting Top of Form to the Factory Default" later in this chapter.*

## Temporarily Changing the Top of Form Position

### Important

Do **not** use the platen knob to change the Top of Form. If you turn the platen knob when the printer is turned ON, the Top of Form misaligns. Always turn the printer OFF before turning the platen knob!

To move the Top of Form position lower *for one page only*:

1. Press **SEL** to deselect the printer.
2. Press **LF** to lower the position of the Top of Form.

## Resetting Top of Form to the Factory Default

The factory default setting for the Top of Form (where the printing should begin) is 11/12" (23.28 mm) down from the top of the page.

To reset the Top of Form to the factory default:

1. Remove paper from the paper path.
2. Turn the printer *off*.
3. Press and hold **LF/FF + TEAR** while turning on the printer.
4. Reload paper.

## Forms Tear-Off Feature

*Note: This feature is normally turned off. To use Forms Tear-Off, you must enter the menu and change the setting to the desired time interval (see next page).*

The Forms Tear-Off feature allows a printed continuous forms page to be torn off without wasting paper or adjusting the printer. It can be used for rear feed continuous forms, bottom feed continuous forms (with the optional push tractor installed) or for top feed roll paper (with optional roll paper stand installed).

When the printer is turned on, the paper feeds to the tear-off position.

When data is received, the paper automatically moves down to the print position (TOF) and printing begins.

*Note: You can also move the paper down to the print position manually by pressing **TEAR**.*

When printing stops, Forms Tear-Off automatically moves the paper to align the perforation with the tear bar (located under the access cover), after the time interval which you selected through the menu.

Paper remains in the tear-off position until the printer receives more data. Then, the paper moves

back down for printing.

*Notes: The status of the Forms Tear-Off menu setting affects how you set the Top of Form: see "Top of Form (TOF) and Forms Tear-Off" earlier in this chapter.*

*Do not use Forms Tear-Off with labels or multipart forms!*

*Forms Tear-Off cannot be used when the optional pull tractor is engaged.*

## Potential Problems with Software Packages

If Forms Tear-Off is set to On and the software package you are using "pauses" for a long enough interval while sending data to the printer, Forms Tear-Off may be activated. No data is lost, but this causes uneven print registration due to the paper movement.

If this occurs, use the menu to turn off this feature, then use the **TEAR** key to move the paper up to the tear position manually (see next page).

## Changing the Forms Tear-Off Setting

Note: The default setting for Forms Tear-Off is OFF.

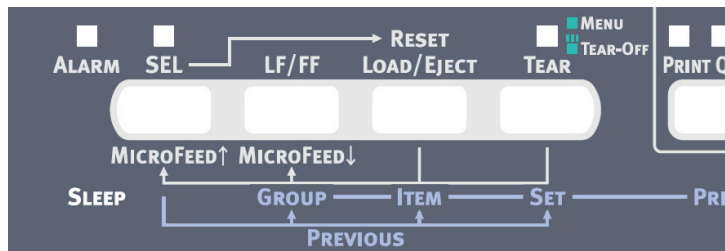

To change the Forms Tear-Off setting:

1. Hold down the **CHR PITCH** key and press the **PRINT SPEED** key.
2. Press **GROUP** repeatedly until the Rear Feed or Bottom Feed group shows in the first column of the printed line, depending on which paper feed you are using.
3. Press **ITEM** repeatedly until Form Tear-Off appears in the second column:

```
Rear Feed      Form Tear-Off  Manual
```

4. Press **SET** until the time interval you wish to select appears in the third column:

```
Rear Feed      Form Tear-Off  1 Sec
```

5. Hold down the **CHR PITCH** key and press the **PRINT SPEED** key to exit Menu Mode and save the setting.

## Manual Forms Tear Off

If you don't wish to engage the Forms Tear-Off feature, you can advance

- rear-feed continuous forms loaded on the built-in tractor  
*or*
- bottom-feed continuous forms loaded on the optional push tractor

up to the tear off position manually by pressing the **LF/FF** key and then pressing **TEAR**.

## Paper Park

### Important!

*Never park labels!*

Paper park allows you to switch to single-sheet printing without removing continuous feed paper from the printer.

To print single cut sheets:

1. Tear off the last page of the continuous form paper.
2. Press the **LOAD/EJECT** key; this causes a Paper Empty alarm.
3. Move the paper Release Lever to the Cut Sheet position.
4. Load the cut sheet of paper.

### To activate the continuous form paper again:

1. Remove cut-sheet paper from the printer.
2. Move the paper Release Lever to Continuous.
3. Press the **LOAD/EJECT** key.

## Setting the Paper Thickness Lever

There are 10 lever positions to adjust printing for the thickness of the paper.

### CAUTION!

*Make sure the printer is turned off before you open the access cover.*

To adjust the lever, open the access cover and move the lever (1) to the recommended setting from the following tables.

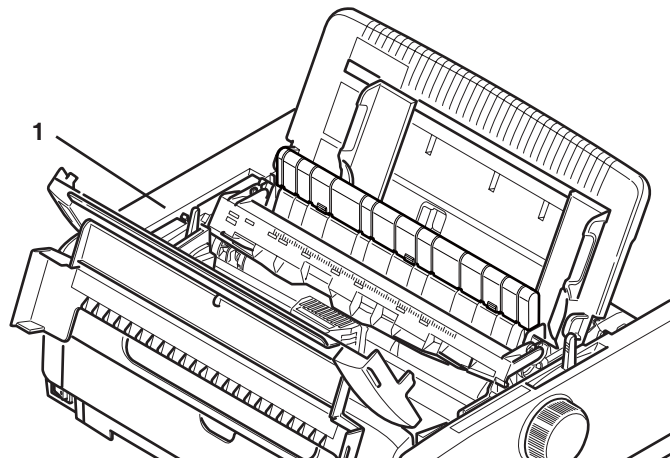



## Paper Type Table

PAPER TYPE	LEVER POSITION									
	1	2	3	4	5	6	7	8	9	10
<b>Cut Sheet Paper</b>										
52-81 g/m <sup>2</sup>	X									
81-128 g/m <sup>2</sup>		X								
128-156 g/m <sup>2</sup>			X							
Post Card				X						
Envelope							X			
<b>Continuous Paper</b>										
52-81 g/m <sup>2</sup>	X									
81-128 g/m <sup>2</sup>		X								
<b>Carbon Paper or Pressure-Sensitive Paper (40 g/m<sup>2</sup>)</b>										
2-part		X								
3-part			X							
4-part				X						
5-part					X					
6-part						X				
7-part							X			

Set the Paper Thickness lever for overall thickness as show below:

Overall Paper Thickness	Lever Position
0.06 - 0.10 mm	1
0.11 - 0.15 mm	2
0.16 - 0.20 mm	3
0.21 - 0.25 mm	4
0.26 - 0.30 mm	5
0.31 - 0.35 mm	6
0.36 - 0.40 mm	7
0.41 - 0.45 mm	8
0.46 - 0.50 mm	9
0.51 - 0.53 mm	10

### NOTES:

*If the lever position does not suit the paper thickness, paper feeding and printing may not work properly.*

*To avoid possible pin breakage/ribbon snagging, do not print on bank books.*

*When lever positions 5-10 are selected, printing quality for carbon paper may decline.*

# Chapter 3:

## Print Settings

This section describes how to set and manage:

- Print Quality
- Character Pitch
- Print Speed
- Emulations

For more print setting options, see the Menu settings in chapter 4.

## Print Quality

### Important!

Front panel settings for print quality and character pitch are normally overridden by software commands.

### Draft: Utility—the default

- Medium quality, medium speed (380 cps)
- Gothic typeface only

### HSD: High Speed Draft

- Lower quality, higher speed (507 cps)
- Gothic typeface only

### SSD: Super Speed Draft

- Lowest quality, highest speed (570 cps)
- Gothic typeface only

### NLQ: Near Letter Quality

- Highest quality, slowest speed (95 cps)
- Courier or Gothic

*Note: Available Print Quality settings depend on which Character Pitch setting is selected.*

There are three **PRINT QUALITY** indicator lights:

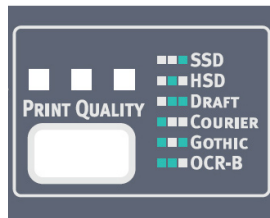

The sequence of lights shows which print quality setting is active:

- SSD
- HSD
- Draft
- Courier
- Gothic
- OCR-B

( = light off,  = light on)

The default **PRINT QUALITY** is "DRAFT."

To change the **PRINT QUALITY** press the **PRINT QUALITY** key. Each time the key is pressed the light sequence above the **PRINT QUALITY** key changes until all the options have been cycled through.

## Character Pitch

### Important!

Front panel settings for character pitch are normally overridden when the SI command is received from your software.

Character pitch determines how many characters will print on each line. You can choose a specific fixed width for each character in characters per inch (CPI), or Proportional. The higher cpi settings are often used for spreadsheets.

Proportional (PROP) sets character widths based on the character itself: e.g., the letter *i* is assigned a narrower width than the letter *m*. This provides a more polished, typeset appearance.

To select Proportional, press the **CHARACTER PITCH** key until *both* of the **CHARACTER PITCH** lights are flashing.

To select non-proportional, press the **CHARACTER PITCH** key until the printer shows the light sequence for the cpi value you want to use.

There are two **CHARACTER PITCH** indicator lights:

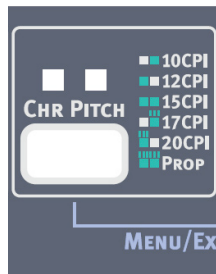

The sequence of lights shows which character pitch is active:

- 10 CPI
- 12 CPI
- 15 CPI
- 17 CPI
- 20 CPI
- PROPORTIONAL

( = light off,  = light on,  = blinking light)

The default **CHARACTER PITCH** is "20 CPI."

To change the **CHARACTER PITCH** press the **CHR PITCH** key. Each time the key is pressed the light sequence above the **CHARACTER PITCH** key changes until all the options have been cycled through.

## Print Speed

There are two **PRINT SPEED** indicator lights:

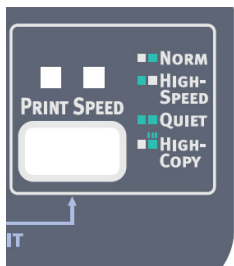

The sequence of lights shows which print speed is active:

- Normal
- HIGH-SPEED
- QUIET
- HIGH-COPY

( = light off,  = light on,  = blinking light)

The default **PRINT SPEED** is "Normal."

To change the **PRINT SPEED** press the **PRINT SPEED** key. Each time the key is pressed the light sequence above the **PRINT SPEED** key changes until all the options have been cycled through.

## Printer Reset

Clearing some error conditions requires that you reset (re-initialize) the printer. To do this:

1. Press and release **SEL** to take the printer off-line.  
*The **SEL** light goes out.*
2. Hold down the **SEL** key and press the **LOAD/EJECT** key.

### Important!

*Pressing **LOAD/EJECT** re-initializes the printer, but does **not** affect any menu settings and does **not** reset the printer to the factory defaults. For information on resetting the printer to the factory defaults, see "Resetting the Menu to the Factory Defaults" in chapter 4.*

## Emulations

- IBM® Proprinter III — *factory setting*
- Epson® FX
- Oki® MICROLINE®

## Changing Emulations

1. Make sure paper is loaded.
2. Press **SEL**.
3. Hold down the **CHR PITCH** key and press the **PRINT SPEED** key.

4. Press **LF/FF**.

*The following line prints:*

```
Printer Control  Emulation Mode  IBM PPR
```

5. Press **TEAR** repeatedly until the emulation you wish to select prints in the right-hand column.
6. Hold down the **CHR PITCH** key and press the **PRINT SPEED** key to exit Menu Mode.

# Chapter 4: Menu Mode

*Note: Please print the current Menu Mode settings before you reset or change them. This is the only way to have a record of the settings.*

In Menu Mode, you use the front panel keys to change the defaults for the printer parameters. The changes you make in the Menu Mode are automatically saved when you exit the Menu Mode and are retained, even when you turn the printer off.

See the Menu Settings Table for a complete list of all the menu options. Features include Printer Control, Font, Symbol Sets, Rear Feed (Push), Front Feed (Push), Pull, Cut Sheet (Top), Cut Sheet (Front), and Setup.

## Menu Mode Keys

Use the purple “sub-menu” labels on the Control Panel that are below the gray keys to identify functions:

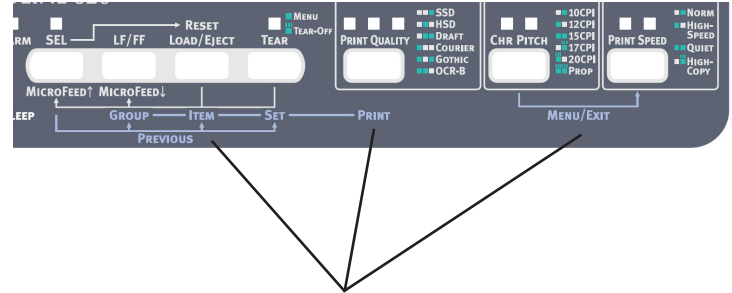

## Menu Mode Keys and Functions

The following table describes the function of the keys in Menu Mode.

<b>Menu Mode Keys and Functions</b>	
<b>Key</b>	<b>Function</b>
<b>GROUP</b>	<p>A <b>GROUP</b> is a general categorization of functions/features.</p> <p>Use the <b>GROUP</b> key to cycle forward through the options. Each time <b>GROUP</b> is pressed the next Group menu option is printed. When the group you want to change is displayed, use the <b>ITEM</b> key to cycle through that group's items.</p>
<b>ITEM</b>	<p>An <b>ITEM</b> is a direct name of functions/features.</p> <p>Use the <b>ITEM</b> key to cycle forward through the options. Each time <b>ITEM</b> is pressed the next Item menu is printed. When the item you want to change is displayed, use the <b>SET</b> key to cycle through that item's options.</p>

<b>Menu Mode Keys and Functions</b>	
<b>Key</b>	<b>Function</b>
<b>SET</b>	<p>A <b>SET</b> is a value (setting) for an <b>ITEM</b>.</p> <p>Use the <b>SET</b> key to cycle forward through the options. Each time <b>SET</b> is pressed the next Setting menu option is printed. When the setting you want to change is displayed, you can go back to the <b>ITEM</b> or <b>GROUP</b> keys to change additional menu options or exit Menu Mode.</p>
<b>PRINT</b>	Prints a list of the current Menu settings.
<b>SEL + LL/FF</b>	Use this key sequence to cycle backward through the Group options.
<b>SEL + LOAD/EJECT</b>	Use this key sequence to cycle backward through the Item options.
<b>SEL + TEAR</b>	Use this key sequence to cycle backward through the Set options.
<b>CHR PITCH + PRINT SPEED</b>	Exits MENU mode.



## Entering and Exiting Menu Mode

### To activate Menu Mode:

1. Press the **SEL** key to take the printer offline (the **SEL** light will turn off).
2. Hold down the **CHR PITCH** key and press the **PRINT SPEED** key. This toggles the menu on (i.e., “enters” the menu) and makes the **GROUP**, **ITEM**, **SET**, and **PRINT** keys active.
3. Use the **GROUP**, **ITEM**, **SET**, and **PRINT** keys to perform the functions as described in the Menu Mode Keys and Functions table.

### To turn Menu Mode off:

1. Hold down the **CHR PITCH** key and press the **PRINT SPEED** key. This toggles the menu off (i.e., “exits” the Menu).

## Resetting the Menu to the Factory Defaults

*Note: Please print the current Menu Mode settings before you reset or change them. This is the only way to have a record of the settings.*

To reset the Menu to the standard settings (factory defaults):

1. Turn the printer off.
2. Press and hold down the **SEL** and **LF/FF** keys at the same time while turning the printer ON. The **SEL** light will flash.
3. Press and hold down the **TEAR** key and then press the **SEL** key again to put the printer online.

## Printing the Menu Settings

### Printing the Current Menu Settings

1. Make sure paper is loaded in the printer.
2. Press the **SEL** key to take the printer offline (the **SEL** light will turn off).
3. While pressing the **CHR PITCH** key, press the **PRINT SPEED** key.
4. Press the **PRINT QUALITY** key.

### Printing All Menu Settings

To print out a listing of the settings for all menu items, regardless of the emulation selected or the accessories installed:

1. Make sure paper is loaded in the printer.
2. Press the **SEL** key to take the printer offline (the **SEL** light will turn off).
3. Hold down the **CHR PITCH** key and then press the **PRINT SPEED** key.
4. Press the **PRINT QUALITY** key.

## Changing the Menu Settings

*Note: Please print the current Menu Mode settings before you reset or change them. This is the only way to have a record of the settings.*

1. Press the **SEL** key to take the printer offline (the **SEL** light will turn off).
2. Use the **GROUP**, **ITEM** and **SET** keys to make your changes:
  - a *Press **GROUP** until the Group you wish to change appears in the first column.*
  - b *Press **ITEM** until the Item you wish to change appears in the second column.*
  - c *Press **SET** until the setting you want appears in the third column.*
3. When you have finished making changes, hold down the **CHR PITCH** key and then press the **PRINT SPEED** key to exit Menu Mode and save the settings.

### **Important!**

*If you turn off the printer without first exiting the Menu Mode, the changes you have made will be lost.*

## Menu Settings Table

For a complete explanation of each menu item, see “Explanations of Menu Items” later in this chapter.

The table below shows the items which may appear in the menu. Settings which are engaged at the factory (defaults) are set in ***bold italic***. Some groups or entries will only appear when a specific emulation is engaged, as noted.

<b><i>MENU SETTINGS TABLE</i></b>			
<b><i>Group</i></b>	<b><i>Item</i></b>	<b><i>Function</i></b>	<b><i>Settings</i></b> (defaults are set in <b><i>bold italic</i></b> )
Printer Control	Emulation Mode	Selects the printer command set (emulation) you want to engage.	<b><i>IBM PPR</i></b> , Epson FX, ML
Font	Print Mode	Choose the quality and typeface of printing. Switch to NLQ Courier or NLQ Gothic for Near Letter Quality printing. If you are printing draft-type documents, select DRAFT, then select either HSD or SSD under DRAFT Mode. Both of these Items are in the Font Group.	<b><i>Draft</i></b> , NLQ Courier, NLQ Gothic, NLQ OCR-B, HSD, SSD
	Draft Mode	Applies only when the Print Mode is set to DRAFT. Selects the draft mode to be used: HSD (High Speed Draft) or SSD (Super Speed Draft).	<b><i>HSD</i></b> , SSD
	Pitch	Choose the character width, in characters per inch (cpi).	<b><i>10 cpi</i></b> , 12 cpi, 15 cpi, 17.1 cpi, 20 cpi

**MENU SETTINGS TABLE**

<b>Group</b>	<b>Item</b>	<b>Function</b>	<b>Settings</b> (defaults are set in <b><i>bold italic</i></b> )
Font ( <i>cont.</i> )	Proportional Spacing	Change the setting to Yes to engage proportional spacing of characters.	<b>No</b> , Yes
	Style	Change to italics if you want the printed characters to be slanted.	<b>Normal</b> , Italics
	Size <sup>1</sup>	Change to Double for double width and height printing.	<b>Single</b> , Double
Symbol Sets	Character Set	Select the character code table. The default is Set II. Use Set I for Epson and IBM emulations only. For MICROLINE emulations, use Standard, Line Graphics, or Block Graphics.	<ul style="list-style-type: none"> <li>• <b>Set I</b>, Set II</li> <li>• Standard, Line Graphics, Block Graphics [ML Mode only]</li> </ul>
	Language Set	Replaces certain standard symbols with special characters used in foreign languages.	<b>American</b> , French, German, British, Danish I, Swedish, Italian, Spanish I, Japanese, Norwegian, Danish II, Spanish II, Latin American, French Canadian, Dutch, Publisher
	Zero Character	If you do not want the printer to use a slash to distinguish the number zero from the capital letter O, change the setting to Unslashed.	<b>Slashed</b> , Unslashed

**MENU SETTINGS TABLE**

<b>Group</b>	<b>Item</b>	<b>Function</b>	<b>Settings</b> (defaults are set in <b>bold italic</b> )
Symbol Sets ( <i>cont.</i> )	Code Page	Choose the Code Page character set you wish to use.	<b>USA</b> , Canada French, Multilingual, Portugal, Norway, Turkey, Greek_437, Greek_869, Greek_928, Greek_437 CYPRUS, Polska Mazovia, Serbo Croatic I, Servo Croatic II, ECMA-94, Hungarian CWI, Windows Greek, Windows East Europe, Windows Cyrillic, East Europe Latin II - 852, Cyrillic I-855, Cyrillic II-866, Kamenicky (MJK), ISO Latin 2, Hebrew NC (862), Hebrew OC, Turkey_857, Latin 5 (Windows Turkey), Windows Hebrew, Ukranian, Bulgarian, ISO Latin 6 (8859/10), Windows Baltic, Baltic_774, KBL-Lithuanian, Cyrillic Latvian, Roman-8, Icelandic-861, Multilingual 858, ISO 8859-15, Greek_737, POL 1, Macedonian, BRASCII, Abicomp
Rear Feed (Push)	Line Spacing	Change to 8 lines per inch (lpi) to get more lines on a page.	<b>6 LPI</b> , 8 LPI

**MENU SETTINGS TABLE**

<b>Group</b>	<b>Item</b>	<b>Function</b>	<b>Settings</b> (defaults are set in <b>bold italic</b> )
Rear Feed (Push) (cont.)	Form Tear-Off <sup>5</sup>	Specify manual form paper advancement or select a time; when printer is idle for .5, 1 or 2 seconds, paper is advanced from the current print position to the tear position. When data is received, paper is moved to its original printing position.	<b>Manual</b> , 0.5 sec, 1 sec, 2 sec
	Skip Over Perforation	Specify whether to skip over perforations or not. When a skip-over command is received, it is given priority. If your software has its own page formatting controls, leave the default setting. To set the printer to go to the next page when it comes within 1" (25 mm) of the bottom of the page, change the setting.	<b>No</b> , 25.4 mm (1")
	Page Width <sup>4</sup> (only displayed for ML621)	Change to 8" to print on narrow paper.	<b>13.6"</b> , 8"

**MENU SETTINGS TABLE**

<b>Group</b>	<b>Item</b>	<b>Function</b>	<b>Settings</b> (defaults are set in <b>bold italic</b> )
Rear Feed (Push) (cont.)	Page Length	Specify the length of a continuous form.	3" (76.2 mm), 3.25" (82.6 mm), 3.33" (84.7 mm), 3.5" (88.9 mm), 3.66" (93.1 mm), 4" (101.6 mm), 5" (127 mm), 5.5" (139.7 mm), 6" (152.4 mm), 7" (177.8 mm), 8" (203.2 mm), 8.5" (215.9 mm), <b>11" (279.4 mm)</b> , 11.7" (296.3 mm), 12" (304.8 mm), 14" (355.6 mm), 17" (431.8 mm)
	Initial Position	Paper position (print or cut) when printer is powered on.	<b>Print position</b> , Cut position
	Cut Position Adjust	Specify an adjustment value for where to cut the end of a continuous form.	-20 ~ -1, <b>0</b> , +1 ~ +20
	TOF Adjust	Specify an adjustment value for the reference position for the Top of Form position of a continuous form.  The position moves to the bottom edge of the page (+) and to the top edge of the page (-) in 1/144" increments.	-20 ~ -1, <b>0</b> , +1 ~ +20

**MENU SETTINGS TABLE**

<b>Group</b>	<b>Item</b>	<b>Function</b>	<b>Settings</b> (defaults are set in <b>bold italic</b> )
Rear Feed (Push) ( <i>cont.</i> )	Continuous Paper Top of Form	For continuous forms, sets a TOF in small increments.	1/12" (2.12 mm), 2/12" (4.23 mm), 3/12" (6.35 mm), 4/12" (8.47 mm), 5/12" (10.58 mm), 6/12" (12.70 mm), 7/12" (14.82 mm), 8/12" (16.93 mm), 9/12" (19.05 mm), 10/12" (21.17 mm), <b>11/12" (23.28 mm)</b> , 12/12" (25.40 mm), 13/12" (27.52 mm), User Top of Form
	LF Revise (Continuous Paper Line Feed Adjust)	For continuous feed, adjusts the line feed to the specified amount.	-2, -1, <b>0</b> , +1, +2
	Centering Position	Used to limit printhead travel when printing narrow columns. Select Mode 1 for ML620. Select Mode 1 or Mode 2 for the ML621.	<b>Default</b> , Mode1, Mode2
Front Feed (Push)	Line Spacing	Change to 8 lines per inch (lpi) to get more lines on a page.	<b>6 LPI</b> , 8 LPI
	Form Tear-Off <sup>5</sup>	Specify manual form paper advancement or select a time; when printer is idle for .5, 1 or 2 seconds, paper is advanced from the current print position to the tear position. When data is received, paper is moved to its original printing position.	<b>Manual</b> , 0.5 sec, 1 sec, 2 sec



**MENU SETTINGS TABLE**

<b>Group</b>	<b>Item</b>	<b>Function</b>	<b>Settings</b> (defaults are set in <b>bold italic</b> )
Front Feed (Push) ( <i>cont.</i> )	Skip Over Perforation	Specify whether to skip over perforations or not. When a skip-over command is received, it is given priority. If your software has its own page formatting controls, leave the default setting. To set the printer to go to the next page when it comes within 1" (25 mm) of the bottom of the page, change the setting.	<b>No</b> , 25.4 mm (1")
	Page Width <sup>4</sup> (only displayed for ML621)	Change to 8" to print on narrow paper.	<b>13.6"</b> , 8"
	Page Length	Specify the length of a continuous form.	3" (76.2 mm), 3.25" (82.6 mm), 3.33" (84.7 mm), 3.5" (88.9 mm), 3.66" (93.1 mm), 4" (101.6 mm), 5" (127 mm), 5.5" (139.7 mm), 6" (152.4 mm), 7" (177.8 mm), 8" (203.2 mm), 8.5" (215.9 mm), <b>11" (279.4 mm)</b> , 11.7" (296.3 mm), 12" (304.8 mm), 14" (355.6 mm), 17" (431.8 mm)
	Initial Position	Paper position (print or cut) when printer is powered on.	<b>Print position</b> , Cut position

**MENU SETTINGS TABLE**

<b>Group</b>	<b>Item</b>	<b>Function</b>	<b>Settings</b> (defaults are set in <b>bold italic</b> )
Front Feed (Push) (cont.)	Cut Position Adjust	Specify an adjustment value for where to cut the end of a continuous form.	-20 ~ -1, <b>0</b> , +1 ~ +20
	TOF Adjust	Specify an adjustment value for the reference position for the Top of Form position of a continuous form.  The position moves to the bottom edge of the page (+) and to the top edge of the page (-) in 1/144" increments.	-20 ~ -1, <b>0</b> , +1 ~ +20
	Continuous Paper Top of Form	For continuous forms, sets a TOF in small increments.	1/12" (2.12 mm), 2/12" (4.23 mm), 3/12" (6.35 mm), 4/12" (8.47 mm), 5/12" (10.58 mm), 6/12" (12.70 mm), 7/12" (14.82 mm), 8/12" (16.93 mm), 9/12" (19.05 mm), 10/12" (21.17 mm), <b>11/12" (23.28 mm)</b> , 12/12" (25.40 mm), 13/12" (27.52 mm), User Top of Form
	LF Revise (Continuous Paper Line Feed Adjust)	For continuous feed, adjusts the line feed to the specified amount.	-2, -1, <b>0</b> , +1, +2

**MENU SETTINGS TABLE**

<b>Group</b>	<b>Item</b>	<b>Function</b>	<b>Settings</b> (defaults are set in <b>bold italic</b> )
Front Feed (Push) (cont.)	Centering Position	Used to limit printhead travel when printing narrow columns. Select Mode 1 for ML620. Select Mode 1 or Mode 2 for the ML621.	<b>Default</b> , Mode1, Mode2
Pull	Line Spacing	Change to 8 lines per inch (lpi) to get more lines on a page.	<b>6 LPI</b> , 8 LPI
	Skip Over Perforation	Specify whether to skip over perforations or not. When a skip-over command is received, it is given priority. If your software has its own page formatting controls, leave the default setting. To set the printer to go to the next page when it comes within 1" (25 mm) of the bottom of the page, change the setting.	<b>No</b> , 25.4 mm (1")
	Page Width (only displayed for ML621) <sup>4</sup>	Change to 8" to print on narrow paper.	<b>13.6"</b> , 8"

**MENU SETTINGS TABLE**

<b>Group</b>	<b>Item</b>	<b>Function</b>	<b>Settings</b> (defaults are set in <b>bold italic</b> )
Pull ( <i>cont.</i> )	Page Length	Specify the length of a continuous form.	3" (76.2 mm), 3.25" (82.6 mm), 3.33" (84.7 mm), 3.5" (88.9 mm), 3.66" (93.1 mm), 4" (101.6 mm), 5" (127 mm), 5.5" (139.7 mm), 6" (152.4 mm), 7" (177.8 mm), 8" (203.2 mm), 8.5" (215.9 mm), <b>11" (279.4 mm)</b> , 11.7" (296.3 mm), 12" (304.8 mm), 14" (355.6 mm), 17" (431.8 mm)
	LF Revise (Continuous Paper Line Feed Adjust)	For continuous feed, adjusts the line feed to the specified amount.	-2, -1, <b>0</b> , +1, +2
	Centering Position	Used to limit printhead travel when printing narrow columns. Select Mode 1 for ML620. Select Mode 1 or Mode 2 for the ML621.	<b>Default</b> , Mode1, Mode2
Cut Sheet Top Feed	Line Spacing	Change to 8 lines per inch (lpi) to get more lines on a page.	<b>6 LPI</b> , 8 LPI
	Form Tear-Off <sup>5, 6</sup> (Displayed when connected to RPS)	Specify manual form paper advancement or select a time; when printer is idle for .5, 1 or 2 seconds, paper is advanced from the current print position to the tear position. When data is received, paper is moved to its original printing position.	<b>Manual</b> , 0.5 sec, 1 sec, 2 sec

**MENU SETTINGS TABLE**

<b>Group</b>	<b>Item</b>	<b>Function</b>	<b>Settings</b> (defaults are set in <b>bold italic</b> )
Cut Sheet Top Feed (cont.)	Page Width (only displayed for ML621) <sup>4</sup>	Change to 8" to print on narrow paper.	<b>13.6"</b> , 8"
	Page Length	Specify the length of a cut sheet page.	3" (76.2 mm), 3.25" (82.6 mm), 3.33" (84.7 mm), 3.5" (88.9 mm), 3.66" (93.1 mm), 4" (101.6 mm), 5" (127 mm), 5.5" (139.7 mm), 6" (152.4 mm), 7" (177.8 mm), 8" (203.2 mm), 8.5" (215.9 mm), <b>11" (279.4 mm)</b> , 11.7" (296.3 mm), 12" (304.8 mm), 14" (355.6 mm), 17" (431.8 mm)
	Initial Position <sup>6</sup> [Displayed when connected to RPS]	Paper position (print or cut) when printer is powered on.	<b>Print position</b> , Cut position
	Cut Position Adjust <sup>6</sup> [Displayed when connected to RPS]	Specify an adjustment value for where to cut the roll paper.	-20 ~ -1, <b>0</b> , +1 ~ +20
	Wait Time	Specify the wait time from when the paper is set on the tray to when the printer feeds it.	Invalid, 0.5 sec, <b>1 sec</b> , 1.5 sec, 2 sec, 3 sec
	Paper Length Control	Specify the page length of a cut sheet.	by Menu Setting, <b>by Actual Page Length</b>

**MENU SETTINGS TABLE**

<b>Group</b>	<b>Item</b>	<b>Function</b>	<b>Settings</b> (defaults are set in <b>bold italic</b> )
Cut Sheet Top Feed (cont.)	Cut Sheet Auto Eject Position	For cut sheets, when it reaches the selected measurement, measured from the bottom of the page, it ejects the paper.	<b>.25" (6.35 mm)</b> , .5" (12.7 mm), 7/12" (14.82 mm), Invalid
	TOF Adjust	Specify an adjustment value for the reference position for the Top of Form position.  The position moves to the bottom edge of the page (+) and to the top edge of the page (-) in 1/144" increments.	-20 ~ -1, <b>0</b> , +1 ~ +20
	Cut Sheet Top of Form	Specify an adjustment value for the reference position for the Top of Form when feeding a cut sheet (up to the mid-section of characters in the first line).	1/12" (2.12 mm), 2/12" (4.23 mm), 3/12" (6.35 mm), 4/12" (8.47 mm), 5/12" (10.58 mm), 6/12" (12.70 mm), 7/12" (14.82 mm), 8/12" (16.93 mm), 9/12" (19.05 mm), 10/12" (21.17 mm), <b>11/12" (23.28 mm)</b> , 12/12" (25.40 mm), 13/12" (27.52 mm), User Top of Form
	LF Revise	Adjust the line feed in cut sheet mode.	-14 ~ -1, <b>0</b> , +1 ~ +14

**MENU SETTINGS TABLE**

<b>Group</b>	<b>Item</b>	<b>Function</b>	<b>Settings</b> (defaults are set in <b>bold italic</b> )
Cut Sheet Top Feed ( <i>cont.</i> )	Centering Position	Used to limit printhead travel when printing narrow columns. Select Mode 1 for ML620. Select Mode 1 or Mode 2 for the ML621.	<b>Default</b> , Mode1, Mode2
Cut Sheet Front Feed	Line Spacing	Change to 8 lines per inch (lpi) to get more lines on a page.	<b>6 LPI</b> , 8 LPI
	Page Width (only displayed for ML621) <sup>4</sup>	Change to 8" to print on narrow paper.	<b>13.6"</b> , 8"
	Page Length	Specify the length of a cut sheet page.	3" (76.2 mm), 3.25" (82.6 mm), 3.33" (84.7 mm), 3.5" (88.9 mm), 3.66" (93.1 mm), 4" (101.6 mm), 5" (127 mm), 5.5" (139.7 mm), 6" (152.4 mm), 7" (177.8 mm), 8" (203.2 mm), 8.5" (215.9 mm), <b>11" (279.4 mm)</b> , 11.7" (296.3 mm), 12" (304.8 mm), 14" (355.6 mm), 17" (431.8 mm)
	Wait Time	Specify the wait time from when the paper is set on the tray to when the printer feeds it.	Invalid, 0.5 sec, 1 sec, <b>1.5 sec</b> , 2 sec, 3 sec

**MENU SETTINGS TABLE**

<b>Group</b>	<b>Item</b>	<b>Function</b>	<b>Settings</b> (defaults are set in <b>bold italic</b> )
Cut Sheet Front Feed (cont.)	Paper Length Control	If you are printing single sheets no longer than 17 inches and wish the printer to acknowledge the menu setting for Top Feed Page Length, change the setting to "by Menu Setting."	by Menu Setting, <b>by Actual Page Length</b>
	Cut Sheet Auto Eject Position	For cut sheets, when it reaches the selected measurement, measured from the bottom of the page, it ejects the paper.	<b>.25" (6.35 mm)</b> , .5" (12.7 mm), 7/12" (14.82 mm), Invalid
	TOF Adjust	Specify an adjustment value for the reference position for the Top of Form position.  The position moves to the bottom edge of the page (+) and to the top edge of the page (-) in 1/144" increments.	-20 ~ -1, <b>0</b> , +1 ~ +20
	Cut Sheet Top of Form	Specify an adjustment value for the reference position for the Top of Form when feeding a cut sheet (up to the mid-section of characters in the first line).	1/12" (2.12 mm), 2/12" (4.23 mm), 3/12" (6.35 mm), 4/12" (8.47 mm), 5/12" (10.58 mm), 6/12" (12.70 mm), 7/12" (14.82 mm), 8/12" (16.93 mm), 9/12" (19.05 mm), 10/12" (21.17 mm), <b>11/12" (23.28 mm)</b> , 12/12" (25.40 mm), 13/12" (27.52 mm), User Top of Form



**MENU SETTINGS TABLE**

<b>Group</b>	<b>Item</b>	<b>Function</b>	<b>Settings</b> (defaults are set in <b>bold italic</b> )
Cut Sheet Front Feed ( <i>cont.</i> )	LF Revise	Adjust the line feed in cut sheet mode.	-14 ~ -1, <b>0</b> , +1 ~ +14
	Centering Position	Used to limit printhead travel when printing narrow columns. Select Mode 1 for ML620. Select Mode 1 or Mode 2 for the ML621.	<b>Default</b> , Mode1, Mode2
Set-Up	Graphics	Set the printing direction when a line has double-height print data. Specify uni-directional graphics for better registration, but slower printing.	Bi-directional, <b>Uni-directional</b>
	7 or 8 Bit Graphics <sup>7</sup> (only displayed for ML Emulation)	Change this setting to 8 if your system uses 8-bit graphics.	8, <b>7</b>
	Receive Buffer Size <sup>2</sup>	Selects the amount of memory devoted to holding received data. Choosing "1 Line" will tie up your computer while printing, but if you abort the print job, the printer will stop much sooner.	1 Line, 32K, 64K, <b>128K</b>
	Paper End Detection	Set whether to detect paper end or not. To override the sensor and print closer to the bottom of the page, set to OFF.	<b>On</b> , Off

**MENU SETTINGS TABLE**

<b>Group</b>	<b>Item</b>	<b>Function</b>	<b>Settings</b> (defaults are set in <b>bold italic</b> )
Set-Up (cont.)	Print Registration 1	Adjust the print starting position on printing in the reverse direction. The position moves to the right or left in 1/720" increments.	-10 ~ -1, <b>0</b> , +1 ~ +10
	Print Registration 2	Adjust the print starting position on printing in the reverse direction. The position moves to the right or left in 1/720" increments.	-10 ~ -1, <b>0</b> , +1 ~ +10
	Print Registration 3	Adjust the print starting position on printing in the reverse direction. The position moves to the right or left in 1/720" increments.	-10 ~ -1, <b>0</b> , +1 ~ +10
	Print Registration 4	Adjust the print starting position on printing in the reverse direction. The position moves to the right or left in 1/720" increments.	-10 ~ -1, <b>0</b> , +1 ~ +10
	7 or 8 Bits Data Word <sup>7</sup> (only displayed for ML Emulation)	Change this setting to 7 if your system uses 7-bit data word lengths.	<b>8, 7</b>

**MENU SETTINGS TABLE**

<b>Group</b>	<b>Item</b>	<b>Function</b>	<b>Settings</b> (defaults are set in <b>bold italic</b> )
Set-Up ( <i>cont.</i> )	Operator Panel Function <sup>3</sup>	Set control panel operation. <i>Limited</i> operation locks functions on the control panel; only SEL, LOAD/EJECT, and TEAR keys work.	<b>Full Operation</b> , Limited Operation
	Reset Inhibit	To prevent a reset signal from the computer from resetting the printer to its defaults, set to Yes.	<b>No</b> , Yes
	Print Suppress Effective	Set whether to enable or disable a print suppress setup command.	No, <b>Yes</b>
	Auto LF	Set whether to perform automatic line feed operation or not upon receiving a CR code. If your printout is consistently double-spaced, select No; if it overprints, select Yes.	<b>No</b> , Yes
	Auto CR <sup>8</sup> (only displayed for IBM Emulation)	If you want the printer to automatically add a carriage return when a Line Feed is received at the end of a line, change the setting to "Yes."	<b>No</b> , Yes
	Print DEL Code <sup>7</sup> (only displayed for ML Emulation)	To print the DEL code (decimal 27) as a solid box, set to Yes.	<b>No</b> , Yes

**MENU SETTINGS TABLE**

<b>Group</b>	<b>Item</b>	<b>Function</b>	<b>Settings</b> (defaults are set in <b>bold italic</b> )
Set-Up (cont.)	SI Select Pitch (10 cpi) <sup>8</sup> (only displayed for IBM Emulation)	Sets the pitch to be engaged when the printer control panel is set for 10 cpi and the SI command is received.	15 cpi, <b>17.1 cpi</b>
	SI Select Pitch (12 cpi) <sup>8</sup> (only displayed for IBM Emulation)	Sets the pitch to be engaged when the printer control panel is set for 12 cpi and the SI command is received.	<b>12 cpi</b> , 20 cpi
	Time Out Print	If your software spends a long time processing between portions of data it feeds to the printer, change the setting to Invalid to keep your printer from dumping the received data while it is waiting for more.	<b>Valid</b> , Invalid
	Auto Select	Determines whether or not your printer will automatically be selected after you load in paper. If you always use the same Top of Form position, keep the default setting of "Yes". When set to "No", the printer will be deselected so that you can set the Top of Form.	No, <b>Yes</b>

**MENU SETTINGS TABLE**

<b>Group</b>	<b>Item</b>	<b>Function</b>	<b>Settings</b> (defaults are set in <b>bold italic</b> )
Set-Up (cont.)	Host Interface	Set which interface the printer uses to receive printing commands.	<b>Auto Interface</b> , Parallel, USB, Optional
	I/F Time Out	Sets the length of time before the interface switches to idle status when no printing commands have been received.	<b>15 sec</b> , 30 sec, 45, sec, 1 min, 2 min, 3 min, 4 min, 5 min
	ESC SI Pitch <sup>8</sup> (only displayed for IBM Emulation)	Sets the character pitch used when the ESC SI command is received.	<b>17.1 cpi</b> , 20 cpi
	Select Language Set <sup>9</sup> (only displayed for EPSON Emulation)	Select "combined" to set both country and language; select "code page only" for language only.	<b>Combined</b> , Code Page Only
	Print Style	Sets the printer impact mode.	<b>Normal</b> , High Speed, Quiet, High Copy
	Select Quiet Mode	Quiet modes print slower and quieter. In Mode1, the printer makes one pass; in Mode2, two passes.	<b>Mode1</b> , Mode2
	Select High Copy Mode	High copy modes set the printer to print more forcefully. Mode1 is a double-strike print; Mode2 is triple-strike, etc.	<b>Mode1</b> , Mode2, Mode3, Mode4

**MENU SETTINGS TABLE**

<b>Group</b>	<b>Item</b>	<b>Function</b>	<b>Settings</b> (defaults are set in <i>bold italic</i> )
Set-Up (cont.)	Reverse Feed Control	In reverse feed the paper is reverse fed back to the original printing position.	TOF Stop, <b><i>TOF Over</i></b>
	Print Direction at DH Mode	Set the print direction when printing double-height characters. In uni-directional printing the print head only moves from left to right; in bi-directional printing the print head moves in both directions.	Uni-directional, <b><i>Bi-directional</i></b>
	Sleep Mode	Default setting saves power by having the printer go into sleep mode; when disabled the printer never goes into sleep mode.	<b><i>Enable</i></b> , Disable
	Sleep Time	Set the idle time before the printer enters sleep mode (when Sleep Mode is enabled).	<b><i>5 min</i></b> , 10 min, 15 min, 30 min, 60 min
	Paper End	In default setting when paper end is detected, printer remains on-line; if set to Off-line, when paper end is detected, printer goes off-line.	<b><i>On-line</i></b> , Off-line

**MENU SETTINGS TABLE**

<b>Group</b>	<b>Item</b>	<b>Function</b>	<b>Settings</b> (defaults are set in <b>bold italic</b> )
Set-Up (cont.)	FF Function	Set the feeding operation upon receiving an FF code after cut sheet paper is fed.	Eject, <b>Form Feed</b>
	Cut Sheet Park Function	To enable paper feed out of the cut sheet feeder, set to Valid.	<b>Invalid</b> , Valid
	Feed Up when Menu Printing	To move the paper to the top cover to see the Menu printing, set to Yes.	<b>No</b> , Yes
Parallel I/F	I-Prime	Determines what the printer will do when it receives the I-Prime signal from the software.  Buffer Print: prints out the buffer contents before resetting.  Buffer Clear: dumps the buffer contents immediately.  Invalid: causes the printer to ignore the I-Prime command. Select this setting if you wish to enter settings through the printer's control panel which will not be automatically overridden by the software's settings when the I-Prime signal is sent.	<b>Buffer Print</b> , Buffer Clear, Invalid

**MENU SETTINGS TABLE**

<b>Group</b>	<b>Item</b>	<b>Function</b>	<b>Settings</b> (defaults are set in <b><i>bold italic</i></b> )
Parallel I/F ( <i>cont.</i> )	Auto Feed XT <sup>9</sup> (only displayed for EPSON Emulation)	If your system uses pin 14 of the parallel interface to control automatic line feed, change the setting to Valid.	<b><i>Invalid</i></b> , Valid
	Bi-Direction	Set whether to return a device ID or not in accordance with IEEE 1284.	<b><i>Enable</i></b> , Disable
Serial IF ( <i>Appears only when the optional Serial Interface is installed.</i> )	Parity	Selects the type of parity your system uses: None, Odd, or Even, Ignore (do not convert the character to ox40 in case of parity error).	<b><i>None</i></b> , Odd, Even, Ignore
	Serial Data 7/8 Bits	Change to 7 Bits if your systems uses a 7-bit data format.	<b><i>8 Bits</i></b> , 7 Bits
	Protocol	Set the communications control method.	Ready/Busy, X-On/X-Off, <b><i>Ready/Busy &amp; X-On/X-Off</i></b>
	Diagnostic Test	To perform input/output diagnosis of RS-232C interface signals, set to Yes.	<b><i>No</i></b> , Yes
	Busy Line	If Ready/Busy protocol (factory default) is selected, you can choose which line your system monitors for a busy signal.	SSD-, SSD+, <b><i>DTR</i></b> , RTS



**MENU SETTINGS TABLE**

<b>Group</b>	<b>Item</b>	<b>Function</b>	<b>Settings</b> (defaults are set in <b>bold italic</b> )
Serial I/F (cont.)	Baud Rate	Set this to match your system's transmission speed.	19200 bps, <b>9600 bps</b> , 4800 bps, 2400 bps, 1200 bps, 600 bps, 300 bps
	DSR Signal	Used with the Ready/Busy protocol (factory default) to select the way your system handles the DSR signal.	<b>Valid</b> , Invalid
	DTR Signal	Change to Ready on Select if the DTR signal is required when the printer is selected (leave as Ready on Power Up if the DTR signal is required when the printer is turned on).	<b>Ready on Power Up</b> , Ready on Select
	Busy Time	Sets the length of the busy signal when the Ready/Busy protocol (factory default) is engaged,	<b>0.2 sec</b> , 1 sec
	Stop Bit	Set the stop bit length.	<b>1 bit</b> , 2 bit
	Receive Error	When "checked" is selected the printer checks for the correct number of bits and sends an error if an incorrect number is found.	<b>Checked</b> , Unchecked

**MENU SETTINGS TABLE**

<b>Group</b>	<b>Item</b>	<b>Function</b>	<b>Settings</b> (defaults are set in <b><i>bold italic</i></b> )
CSF (Cut Sheet Feeder) Bin 1 ( <i>Appears only when the optional Cut Sheet Feeder is installed.</i> )	Line Spacing	Change to 8 lines per inch (lpi) to get more lines on a page.	<b>6 LPI</b> , 8 LPI
	Page Width <sup>4</sup> (only displayed for ML621)	Change to 13.6" to print on wide paper.	<b>8"</b> , 13.6"
	Page Length	Selects the length of the paper you are using. This enables the printer to keep track of the initial printing position (TOF) on each page.	3" (76.2 mm), 3.25" (82.6 mm), 3.33" (84.7 mm), 3.5" (88.9 mm), 3.66" (93.1 mm), 4" (101.6 mm), 5" (127 mm), 5.5" (139.7 mm), 6" (152.4 mm), 7" (177.8 mm), 8" (203.2 mm), 8.5" (215.9 mm), <b>11" (279.4 mm)</b> , 11.7" (296.3 mm), 12" (304.8 mm), 14" (355.6 mm), 16" (420.9 mm), 17" (431.8 mm)
	Cut Sheet Auto Eject Position	When the printer reaches the selected measurement, measured from the bottom of the page, it ejects the paper.	.25" (6.35 mm), .5" (12.7 mm), .58" (14.82 mm), Invalid
	TOF Adjust	Set an adjustment value for the reference position in regard to the TOF position of a cut sheet paper.  The position moves to the bottom edge of the page (+) and to the top edge of the page (-) in 1/144" increments.	-20 ~ -1, <b>0</b> , +1 ~ +20

**MENU SETTINGS TABLE**

<b>Group</b>	<b>Item</b>	<b>Function</b>	<b>Settings</b> (defaults are set in <b>bold italic</b> )
CSF (Cut Sheet Feeder) Bin 1 (cont.)	Cut Sheet Top of Form	Specify an adjustment value for the reference position for the TOF position when feeding a cut sheet (up to the mid-section of characters in the first line).	1/12" (2.12 mm), 2/12" (4.23 mm), 3/12" (6.35 mm), 4/12" (8.47 mm), 5/12" (10.58 mm), 6/12" (12.70 mm), 7/12" (14.82 mm), 8/12" (16.93 mm), 9/12" (19.05 mm), 10/12" (21.17 mm), <b>11/12" (23.28 mm)</b> , 12/12" (25.40 mm), 13/12" (27.52 mm), User Top of Form
	LF Revise	Adjust the line feed in cut sheet mode.	-14 ~ -1, <b>0</b> , +1 ~ +14
	Centering Position	Used to limit printhead travel when printing narrow columns. Select Mode 1 for ML620. Select Mode 1 or Mode 2 for the ML621.	<b>Default</b> , Mode1, Mode2
Extension	Detect Sprocket Hole	For continuous paper set to be fed via the individual Form paper route: the default is to have the printer detect sprocket holes; to turn detection off, set to disable.	<b>Enable</b> , Disable
	Right Margin (Continuous paper)	If the printer data exceeds the width of the paper, printing is truncated column-by-column. Specify a margin from the right edge of the paper.	Right Margin Over, .0394" (1 mm), .12" (3 mm), .2" (5.08 mm), <b>.39" (10 mm)</b> , .51" (13 mm), .59" (15 mm), .79" (20 mm), .98" (25 mm)

**MENU SETTINGS TABLE**

<b>Group</b>	<b>Item</b>	<b>Function</b>	<b>Settings</b> (defaults are set in <b>bold italic</b> )
Extension (cont.)	Right Margin (Cut Sheet)	If the printer data exceeds the width of the paper, printing is truncated column-by-column. Specify a margin from the right edge of the paper.	Right Margin Over, <b>.0394" (1 mm)</b> , .0787" (2 mm), .12" (3 mm), .16" (4 mm), .2" (5 mm), .24" (6 mm)

**Table Footnotes:**

- 1 Selects both double-width and double-height character or single-width and single-height characters.
- 2 When "1 line" ID selected, the receiving buffer size is set to 8K bytes.
- 3 When "Limited Operation" is selected, after exiting MENU, only.
- 4 Displayed only for ML621.
- 5 With Form Tear Off function "on," if the printer is idle for a few moments (approximately 0.5, 1, or 2 seconds), the paper is forward advanced, from the current position, to the tear bar position. If more data is received and processed by the printer, the paper is then automatically reversed feed back to the original printing position.
- 6 Displayed only when the roll paper stand (RPS) is connected.
- 7 Displayed only for ML emulation.
- 8 Displayed only for IBM emulation.
- 9 Displayed only for EPSON emulation.
- 10 Displayed only for serial I/F board mounting.
- 11 Appears only if the optional Cut Sheet Feeder is installed.

# Chapter 5: Maintenance

## Replacing the Ribbon Cartridge

### Important!

Make sure you have the correct replacement ribbon for your printer. The wrong ribbon will **not** print when installed in your printer. Look for the printer model number on the ribbon package.

### Ribbon Cartridge Handling

- Leave unused ribbon cartridges in their packages until needed.
- Careful; the ribbon ink may cause permanent stains.
- Ribbon ink on skin or clothing can usually be removed with soap and water.

1. **Make sure the printer is turned OFF.**
2. Open the access cover, set the Paper Thickness lever to position 10 and center the printhead.

### CAUTION!

The printhead may be HOT!

3. Holding the sides of the ribbon guide, slope it up and out to remove it from the carriage. Make sure the Ribbon Guide is aligned with the cut-away on the Pull Up Roller Assembly.

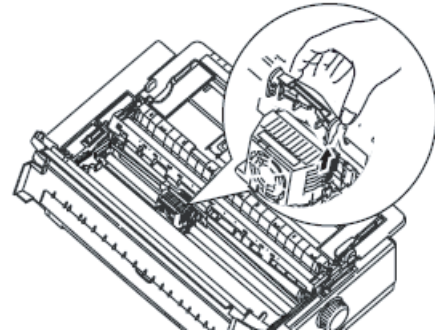

4. Swing the used ribbon cartridge up off the printhead, lift it out, and discard it.

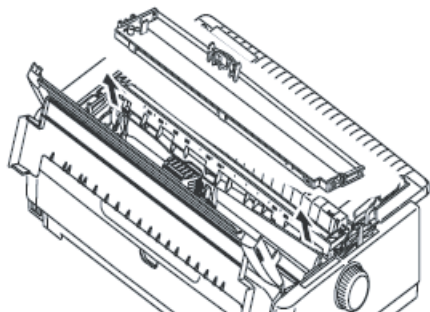

5. Remove the new ribbon cartridge from its wrapping and note the position of the Ribbon Guide (1), Knob (2), and Pin (3).

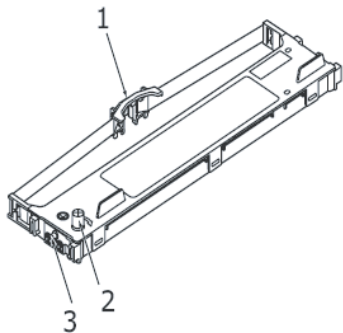

6. In the direction indicated by the arrows,

insert the pins at both ends of the ribbon cartridge (1) into the U grooves (2) in the printer until the ribbon cartridge is fully locked.

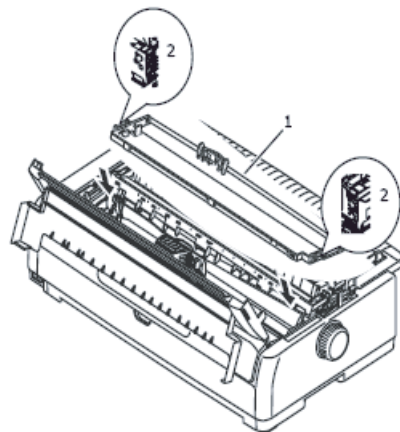

*NOTE: It may be easier to mount the ribbon cartridge in place if you align it with the topside of the grooves. Also, a slightly loose ribbon may make it easier to mount the ribbon cartridge.*

7. Holding the sides of the ribbon guide slope it downward until the ribbon guide comes in line with the slot of the printhead.

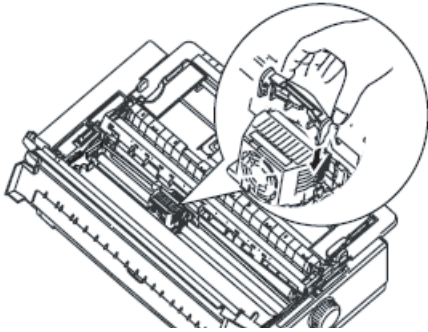

*NOTE: Make sure that the guide is pushed to the end of the printhead.*

8. Move the printhead horizontally to make sure that the ribbon is properly installed.
9. Turn the take-up knob in the direction of the arrow to take up any ribbon slack.

**CAUTION!**

**Do not turn the knob counterclockwise as the ribbon may jam.**

**Make sure that the ribbon is not twisted or damaged when it goes through the gap between the printhead and the ribbon guide.**

10. Set the Paper Thickness lever to match the paper being used.

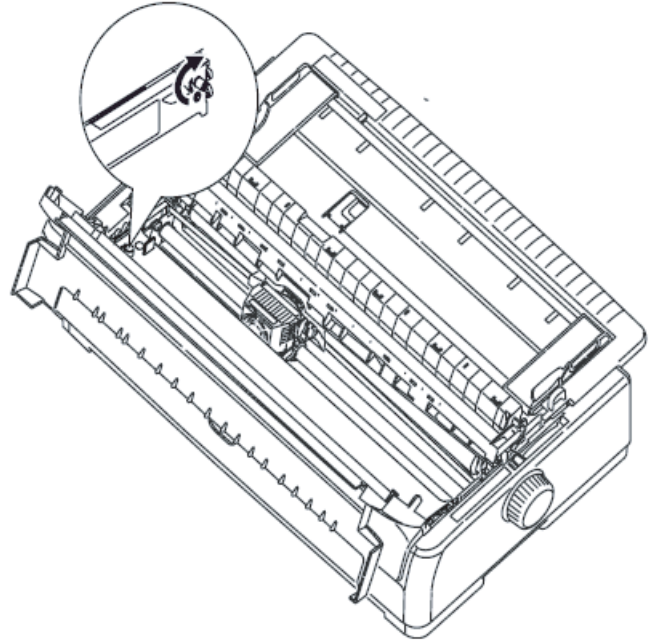

11. Close the access cover and turn the printer back on.

## CAUTION!

### If ribbon should contact the eyes:

Flush eyes with large quantities of water for 15 minutes, keeping eyelids open with fingers. Seek medical attention.

### If ribbon should contact the skin

Wash thoroughly with soap and water.

### For more information

See the Material Safety Data Sheet in your *Warranty, Regulatory, and Safety Information* booklet.

## Clearing Paper Jams

### Continuous Feed Paper Jams

**WARNING:** Do not carry out any operations inside the printer with the Power Switch set to ON.

1. ***Make sure the printer is turned OFF.***
2. Open the access cover.

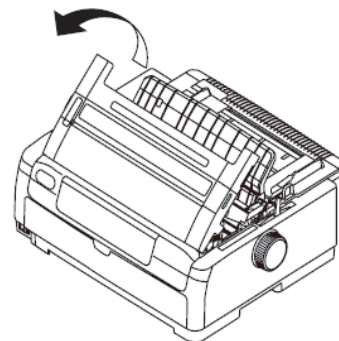

3. Tear off any unprinted continuous forms.
4. Remove the top Paper Tray by holding the tray by the tabs on both sides and pulling it up from the printer.

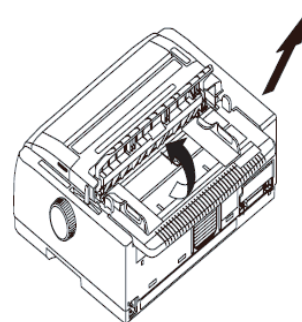



5. Raise each Pin Tractor cover and remove the continuous forms from the Pin Tractors.

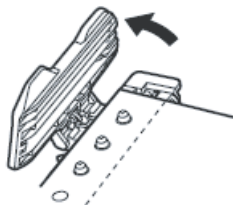

6. Rotate the platen knob and remove the forms from the front of the printer.
7. If a form fragment remains inside the printer, place two or three forms in a stack on the Pin Tractors and turn the platen knob to push the fragment out of the printer.
8. When the paper jams are cleared, lower the top Paper Tray and slide it towards the front of the printer until the marks align.

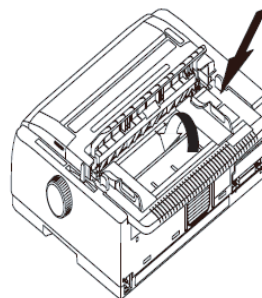

9. Close the access cover and turn the printer back on.

## Cut Sheet Paper Jams

**WARNING:** Do not carry out any operations inside the printer with the Power Switch set to ON.

1. ***Make sure the printer is turned OFF.***
2. Open the access cover.

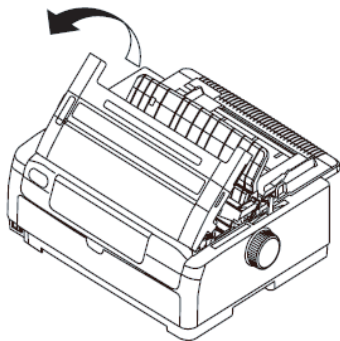

3. Set the Paper Thickness Lever to position 10.

### **CAUTION!**

The printhead may be HOT!

4. Remove the ribbon cartridge. See "Replacing the Ribbon Cartridge."

5. Move the printhead away from the paper.

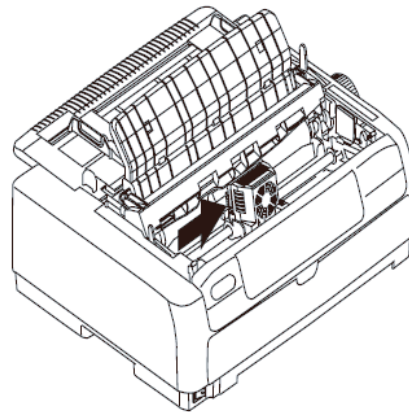

6. Rotate the platen knob in the relevant direction and pull the cut sheet out from the top of the printer.
7. If a paper fragment remains inside the printer:
  - (a) use tweezers to grip and extract it or
  - (b) insert a triple folded sheet from the Paper Tray and turn the platen knob to pass the folded sheet through and push out the paper fragment.



8. When the paper jams are cleared, replace the ribbon cartridge, close the access cover and turn the printer back on.

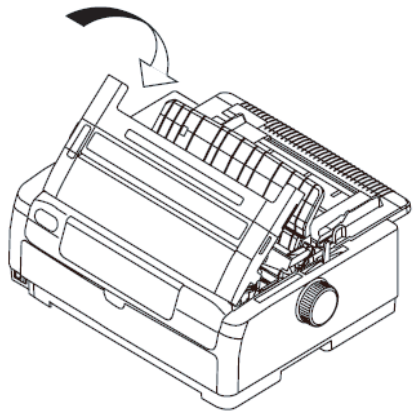

## Cleaning the Printer

To keep your printer in good operating condition, you are advised to clean it regularly.

---

### **WARNING!**

**Turn the printer OFF and disconnect the power cable from the printer before cleaning.**

---

## Printer Exterior

### **CAUTION!**

*Keep the access cover closed to avoid the possibility of detergent entering the printer.*

You should clean the printer housing every six months (or after about 300 hours of operation).

Moisten a piece of cotton cloth with diluted neutral detergent and carefully wipe the printer exterior.

### **CAUTION!**

*Never use strong solvents or strong detergents on the cabinet—they could damage the housing.*

## Printer Interior

---

### **WARNING!**

**Allow the printhead to cool before cleaning inside the printer. To avoid any risk of fire or electric shock, do not use any flammable solvents for cleaning the printer.**

---

You should clean the printer housing every six months (or after about 300 hours of operation).

1. Use the platen knob to back the paper out of the printer.

### **CAUTION!**

*Make sure the printer is turned off before you open the access cover.*

2. Open the access cover and remove the pull-up roller assembly.
3. Use a clean, dry cloth to dust around the carriage shaft and platen. Remove any loose bits of paper.
4. Reinstall the pull-up roller assembly and close the access cover.





## Hexadecimal Dump Mode

When the printer is placed in the Hexadecimal Dump Mode, all data received, including text and printer commands, is printed in both hexadecimal and ASCII format.

For example, the following line of BASIC code

```
LPRINT CHR$(27);"0";CHR$(30);"This is an  
example of a hexadecimal dump."
```

would print like this:

```
1B 30 1B 54 68 69 73 20 69 73 20 61 6E 20 65 78  
61 6D 70 6C 65 20 6F 66 20 61 20 68 65 78 61 64  
65 63 69 6D 61 6C 20 64 75 6D 70 2E 0D 0A
```

*Note: In the ASCII format, all non-printable characters are represented by a period.*

## To engage the Hexadecimal Dump Mode:

1. Make sure paper is loaded.
2. Turn off the printer.
3. Press and hold the **SEL + LF/FF** keys while turning the printer back on.
4. When only the **SEL** indicator is blinking, hold down the **SEL** key and press the **LOAD/EJECT** key.

## To exit the Hexadecimal Dump Mode:

- Turn the printer off.

# Chapter 6: Troubleshooting

## General Information

Here are some general things to check before proceeding with detailed troubleshooting.

- Is the printer plugged in and turned on?
- Are the connections (power and interface) secure?
- Is the product being operated under the proper ambient conditions?
- Does the paper being used meet the specifications for this product?
- Is the paper properly installed?
- Is the ribbon properly installed?
- Is an Oki ribbon being used?
- Is the printhead gap correctly set?
- Are the correct printer drivers being used for the printer?

*Note: Settings in your software application will normally override any settings in your printer driver.*

*Printer driver settings normally override settings from the printer menu or printer front panel.*



## Responding to Alarm Conditions

Use the following table for guidance on how to respond to alarm conditions.

INDICATOR		ALARM MEANINGS AND ACTIONS
SEL	ALARM	
OFF	ON	Paper has run out. Add paper and press the <b>SEL</b> key.
OFF	Flashing	The Paper Type lever is set incorrectly for the type of paper in use. Press the <b>SEL</b> key and move the Paper Type lever to the correct setting.
OFF	Flashing	Problem with cut sheet feeding. Remove the cut sheet.
Flashing	ON	Print data is received but printing does not start because no paper is being fed. Insert paper.
Flashing	Flashing	Printing cannot be resumed at this stage. Turn the power OFF, verify that the carriage moves properly, then turn the power ON again. If the indicator lights continue to flash, contact your dealer.

## Problems / Solutions

Use the following table to help identify symptoms and possible causes and solutions.

<i><b>PROBLEM</b></i>	<i><b>CAUSE</b></i>	<i><b>SOLUTION</b></i>
<b>No power</b>		
No power	The power cable is not properly connected.	Check that the power cable is properly connected at both the power outlet and the printer.
	Power outlet problem or power outage.	Plug another appliance into this outlet to check if it works.
<b>No printing takes place</b>		
<b>SEL</b> indicator is unlit.	The printer driver is not installed properly.	Re-install the printer driver correctly.
	The printer has just stopped printing.	Press the <b>SEL</b> key.
	There is no paper in the printer.	Load paper
<b>SEL</b> indicator is illuminated but no printing takes place.	Interface cable is disconnected.	Reconnect the interface cable.
	Wrong interface cable attached.	Use correct interface cable.
The printhead is moving but no printing takes place.	The ribbon cartridge has not been installed.	Install the ribbon cartridge.
<b>Print position offset</b>		
The horizontal printing position is offset.	The start position may change after the printer is powered on.	When the printer is powered ON, switch from off-line mode to on-line mode by pressing the <b>SEL</b> key. Reset the start position. You must set the Power Switch to OFF before you change the start position.

<b>PROBLEM</b>	<b>CAUSE</b>	<b>SOLUTION</b>
<b>Printing slows down</b>		
Print direction changes suddenly to unidirectional.	When the printhead overheats, the printer automatically starts unidirectional split printing.	The printer will return to its original operation when the printhead temperature drops sufficiently.
<b>Print Error warning</b>		
The print carriage does not operate.	There is contamination on the carriage shaft.	Clean any paper dust and contamination from the carriage with a dry cloth.
<b>Print blurring</b>		
The characters are too pale to display properly on the paper.	The Paper Thickness lever position does not match the paper.	Correct the Paper Thickness lever setting.
	The printer is set to print at high speed.	Set the speed to normal.
	The ribbon has reached its end-of-life.	Replace the ribbon with a new one.
	The ribbon cartridge is not installed correctly.	Reinstall the ribbon cartridge correctly.
	The ribbon has been wound incorrectly.	Replace the ribbon cartridge with a new one.
	The ribbon is not transferring properly.	Replace the ribbon cartridge with a new one.
A line of print is missing.	Broken wire pins.	Contact your dealer.
<b>The printout differs from the screen display</b>		
Printout contains completely different characters or symbols.	Incorrect print setup for the user's application.	Reselect print setup for the applications according to priority.
	The application control codes for the previous print operation are still enabled.	Initialize the printer.

<b>PROBLEM</b>	<b>CAUSE</b>	<b>SOLUTION</b>
	The input application control signal is not correct.	Print in hex-dump mode and verify the data content. Make corrections in the application.
	The interface cable is not properly connected.	Reconnect the cable correctly.
Too high or too low TOF (where printing starts)	The TOF is not correctly selected.	Initialize the printer.
		Select correct TOF for cut sheet and continuous forms.
		Select the first-line print position and adjust the paper top position.
		Reselect the margin correctly in the application.
Too large or small left and/or right margins.	The left or right margin is not correctly selected.	Incorrect positions of the Paper Guide or Pin Tractors. Select and adjust the position again depending on the paper type.
		Reselect the left and right margins correctly in the application.
When continuous forms are used, the content of a single form is printed on two forms.	The paper length selected in the application does not match the physical paper length.	Match the paper length selected in the application with the physical paper length in use.
When cut sheets are used, the content of a single sheet is printed on two sheets.	The paper setting selected in the application does not match the physical paper size.	Match the paper setting selected in the application with the physical paper in use.
	The paper setting does not match the lines per page automatically detected by the printer.	Leave enough top and bottom margin in the application.
		Correct the cut sheet LF adjustment.

<b>PROBLEM</b>	<b>CAUSE</b>	<b>SOLUTION</b>
The content of a single line is printed in two lines.	The left and/or right margins are not correctly selected.	Reselect the left and right margins correctly in the application.
When continuous forms are used, several blank lines appear in the print-out.	Tear-off perforation spacing is selected.	Cancel tear-off perforation spacing.
Broken and uneven vertical lines.	May happen in bidirectional printing.	Adjust the Print Registration.
Too large or small line spacing.	Line spacing is not set correctly.	Reset line spacing correctly in the application.
<b>Split print</b>		
Blanks or deformed characters appear in double-height type or other extended types.	A paper feed error due to line feeding when printing a single character.	Use the printer's built-in fonts when printing important documents or bills.
<b>Improper cut sheet feed</b>		
No paper feed.	Sheets are located off the paper guide.	Load sheets with their left edges against the paper guide.
	Sheets are not loaded to the end.	Load sheets to the end.
Continuous forms instead of cut sheets are fed.	The printer is in the continuous forms mode.	Eject the continuous forms and select the printer's cut sheet mode.
Paper distortion.	Sheets are not loaded to the end, or they are not inserted straight.	Load sheets to the end.
	Paper with wrinkles, folds, or other defects.	Change paper.
	Paper not specified for the printer.	Use paper types specified for the printer.
Unable to eject.	The <b>LF/FF</b> key was pressed.	Press the <b>LOAD/EJECT</b> key.

<b>PROBLEM</b>	<b>CAUSE</b>	<b>SOLUTION</b>
<b>Improper continuous forms feed</b>		
No line feed, and no paper feed.	Paper is off the Pin Tractors.	Reload paper correctly.
	The adjust lever position does not match the paper type.	Set the adjust lever to the correct position.
Paper distortion or jam.	Forms are loaded with their left holes out of line with the right ones.	Load forms with their left holes in line with the right ones.
	Inadequate distance between the left and right Pin Tractors, making for loose paper.	Relocate the Pin Tractors to tighten the paper.
	Skewed paper feeding.	Move the paper to make it straight.
	Paper movement is blocked.	Remove the blockage.
	Paper source is too far from the printer.	Move the paper source nearer to the printer.
	Paper not specified for the printer.	Use paper types specified for this printer.
Several blank lines appear in the print-out	Skip-over perforation spacing is set.	Cancel the skip-over perforation spacing.
The selected skip-over perforation spacing does not match the physical tear-off perforation positions.	The paper length selected in the application does not match the physical paper length.	Match the paper length selected in the application with the physical paper length in use.  Select the paper length in number of lines in the application.
<b>Abnormal switch-over between cut sheet and continuous forms modes</b>		
No cut sheet feed.	The printer is in continuous forms mode.	Set the Paper Type lever to cut sheet mode.
No continuous forms feed.	The printer is in cut sheet mode.	Set the Paper Type lever to continuous forms mode.

<b><i>PROBLEM</i></b>	<b><i>CAUSE</i></b>	<b><i>SOLUTION</i></b>
Paper feed operations for both cut sheets and continuous forms are actuated.	The cut sheet is not ejected.	Eject the cut sheet.

# Appendix A: Parts & Accessories

## Purchasing Parts & Accessories

Before you purchase, know your printer model number (see the front of the unit) and have the correct part number and description of the item. Item descriptions and part numbers are provided in this section.

- Consult the dealer where you purchased your printer.
- Locate an Authorized Oki Data Reseller by visiting one of our web sites

**<http://my.okidata.com>** (allows you to register your product and personalize your own support needs)

**<http://www.okiprintingsolutions.com>** (provides general information)

- In the United States, purchase directly from Oki Data
  - Via the Internet  
[www.okiprintingsolutions.com](http://www.okiprintingsolutions.com)
  - Via telephone
  - Order toll-free by phone at 1-800-654-3282 (1-800-OKI-DATA) using VISA®, MasterCard®, or AmEx®.
- In Canada, call 888-309-4570.



## Consumables

<i>Item</i>	<i>Part Number</i>
<b>Model ML620</b>	
Ribbon	44173403
<b>Model ML621</b>	
Ribbon	44173404

## Accessories

<i>Option</i>	<i>Part Number</i>
<b>Model ML620</b>	
Tractor Assembly (Pull)	44753901
Tractor Assembly (Push)	44454901
Cut Sheet Feeder	44497401
<b>Model ML621</b>	
Tractor Assembly (Pull)	44754001
Tractor Assembly (Push)	44455001
Cut Sheet Feeder	44497501
<b>Both Models</b>	
LAN Card (100BASE-TX/10BASE-T Network Interface)	72008701
RS-232C Serial Interface	44455101
Roll Paper Stand	70023301

# Appendix B: Printer Control Codes

This section lists the most commonly used printer control codes.

You will find a comprehensive listing of the control codes (English only), on your Printer CD.

To access it:

1. Place the CD in your CD-ROM drive and wait for it to AutoPlay.
2. Select your printer model, then click **Continue**.
3. Click **Documentation** and follow the on-screen prompts to view the file.

## IBM Proprinter III Commands

<i>IBM Command</i>	<i>ASCII</i>	<i>Decimal</i>
Backspace	BS	8
Carriage Return	CR	13
Character Pitch		
Select 10 cpi	DC2	18
Select 12 cpi	ESC :	27 58
Select 15 cpi	ESC g	27 103
Select 20 cpi	ESC SI	27 15
Select Condensed Print	SI	15
Character Sets		
IBM Set I	ESC 7	27 55
IBM Set II	ESC 6	27 54

## IBM Proprinter III Commands (continued)

<i>IBM Command</i>	<i>ASCII</i>	<i>Decimal</i>
Double Width On	ESC W 1	27 87 49
Double Width Off	ESC W 0	27 87 48
Emphasized Printing On	ESC E	27 69
Emphasized Printing Off	ESC F	27 70
Enhanced Printing On	ESC G	27 71
Enhanced Printing Off	ESC H	27 72
Form Feed	FF	12
Form Length n inches (n = 1 to 255)	ESC C NUL n	27 67 0 n
n lines (n = 1 to 255)	ESC C n	27 67 n
Horizontal Tab, Execute	HT	9
Italics On	ESC % G	27 37 71
Italics Off	ESC % H	27 37 72

<i>IBM Command</i>	<i>ASCII</i>	<i>Decimal</i>
Line Feed, Execute w/ Carriage Return	LF	10
n/144" (n = 1 to 127)	ESC % 5 n	27 37 53 n
n/216" (n = 0 to 255)	ESC J n	27 74 n
Reverse	ESC ]	27 93
Auto Line Feed On	ESC 5 1	27 53 49
Auto Line Feed Off	ESC 5 0	27 53 48
Line Spacing		
Set Spacing to 1/8"	ESC 0	27 48
Set Spacing to 7/72"	ESC 1	27 49
Set Spacing to n/72" (n = 0 to 255)	ESC A n	27 65 n
Store Spacing Set by ESC A n	ESC 2	27 50
Set Spacing to n/144" (n = 1 to 127)	ESC % 9 n	27 37 57 n
Set Spacing to n/216" (n = 0 to 255)	ESC 3 n	27 51 n

## IBM Proprinter III Commands (continued)

<i>IBM Command</i>	<i>ASCII</i>	<i>Decimal</i>
Overscore On	ESC _ 1	27 95 49
Overscore Off	ESC _ 0	27 95 48
Paper Out Sensor Off	ESC 8	27 56
Paper Out Sensor On	ESC 9	27 57
Select HSD/SSD	ESC # 0	27 35 48
Select Draft	ESC 1 0	27 73 0
Select NLQ Gothic	ESC 1 2	27 73 2
Select NLQ Courier	ESC 1 3	27 73 3
Print Suppress Mode On		
ML620	ESC Q ETX	27 81 3
ML621	ESC Q SYN	27 81 22
Print Suppress Mode Off	DC1	17
Proportional Spacing On	ESC P 1	27 80 49
Proportional Spacing Off	ESC P 0	27 80 48
Reset: Clear Print Buffer	CAN	24

<i>IBM Command</i>	<i>ASCII</i>	<i>Decimal</i>
Software I-Prime	ESC } NUL	27 125 0
Stop Printing	ESC j	27 106
Subscript On	ESC S 1	27 83 49
Superscript On	ESC S 0	27 83 48
Subscript/Superscript Off	ESC T	27 84
Top of Form, Set at Current Position	ESC 4	27 52
Underline Printing On	ESC - 1	27 45 49
Underline Printing Off	ESC - 0	27 45 48
Uni-Directional Print On	ESC U 1	27 85 49
Uni-Directional Print Off	ESC U 0	27 85 48
Vertical Tab, Execute	VT	11

## Epson FX Commands

<i>Epson Command</i>	<i>ASCII</i>	<i>Decimal</i>
Backspace	BS	8
Carriage Return, Execute	CR	13
Character Pitch		
Select 10 cpi	ESC P	27 80
Select 12 cpi	ESC M	27 77
Select 15 cpi	ESC g	27 103
Select Condensed Print	ESC SI, or SI	27 15, or 15
Cancel Condensed Print	DC2	18
Delete	DEL	127
Double Height On	ESC w 1	27 119 49
Double Height Off	ESC w 0	27 119 48
Double Width On	ESC W 1	27 87 49
Double Width Off	ESC W 0	27 87 48
Emphasized Print On	ESC E	27 69
Emphasized Print Off	ESC F	27 70
Enhanced Print On	ESC G	27 71
Enhanced Print Off	ESC H	27 72
Epson Set 1, Select	ESC t 0	27 116 48
Epson Set 2, Select	ESC t 1	27 116 49

<i>Epson Command</i>	<i>ASCII</i>	<i>Decimal</i>
Italic Printing On	ESC 4	27 52
Italic Printing Off	ESC 5	27 53
Form Feed	FF	12
Form Length		
n Inches (n = 1 to 22)	ESC C NUL n	27 67 0 n
n Lines (n = 1 to 127)	ESC C n	27 67 n
Horizontal Tab	HT	9
Justification		
Left	ESC a 0	27 97 48
Center	ESC a 1	27 97 49
Right	ESC a 2	27 97 50
Full	ESC a 3	27 97 51
Line Feed, Execute		
Select 10 cpi	ESC P	27 80
Select 12 cpi	ESC M	27 77
w/ Carriage Return	LF	10
n/216" (n = 0 to 255)	ESC J n	27 74 n
n/144" (n = 0 to 127)	ESC % 5 n	27 37 53 n
Reverse, n/216" (n = 0 to 255)	ESC j n	27 106 n

## Epson FX Commands (continued)

<i>Epson Command</i>	<i>ASCII</i>	<i>Decimal</i>
Line Spacing, Set		
n/144" (n = 0 to 127)	ESC % 9 n	27 37 57 n
n/216" (n = 0 to 255)	ESC 3 n	27 51 n
n/72" (n = 0-85 or 128-213)	ESC A n	27 65 n
1/6"	ESC 2	27 50
1/8"	ESC 0	27 48
7/72"	ESC 1	27 49 n
Paper Out Sensor Off	ESC 8	27 56
Paper Out Sensor On	ESC 9	27 57
Print Quality/Font		
Select HSD/SSD (depends on setting for Draft Mode)	ESC ( 0	27 40 48
Select NLQ	ESC x 1	27 120 49
Select Courier (NLQ only)	ESC k 0	27 107 48
Select Gothic (NLQ only)	ESC k 1	27 107 49
Select Draft	ESC x 0	27 120 48
Print Speed		

<i>Epson Command</i>	<i>ASCII</i>	<i>Decimal</i>
Half-Speed On	ESC s 1	27 115 49
Half-Speed Off	ESC s 0	27 115 48
Print Suppress Mode On	DC3	19
Print Suppress Mode Off	DC1	17
Proportional Spacing On	ESC p 1	27 112 49
Proportional Spacing Off	ESC p 0	27 112 48
Reset Printer		
Clear Buffer & Initialize	ESC @	27 64
Clear Print Buffer	CAN	24
Skip Over Perforation, Cancel	ESC O	27 79
Software I-Prime	ESC } NUL	27 125 0
Subscript On	ESC S 1	27 83 49
Superscript On	ESC S 0	27 83 48
Subscript/Superscript Off	ESC T	27 84
Underline On	ESC - 1	27 45 49
Underline Off	ESC - 0	27 45 48
Uni-Directional Printing		
One Line Only	ESC <	27 60
On	ESC U 1	27 85 49
Off	ESC U 0	27 85 48
Vertical Tab, Execute	VT	11

## Oki MICROLINE Standard Commands

<i>Oki Command</i>	<i>ASCII</i>	<i>Decimal</i>
Backspace	BS	8
Carriage Return	CR	13
Character Pitch		
Select 10 cpi	RS	30
Select 12 cpi	FS	28
Select 15 cpi	ESC g	27 103
Select 17.1 cpi	GS	29
Select 20 cpi	ESC # 3	27 35 51
Character Sets		
Standard	ESC ! 0	27 33 48
Block Graphic	ESC ! 1	27 33 49
Line Graphics	ESC ! 2	27 33 50
Publisher	ESC ! Z	27 33 90
Slashed Zero	ESC ! @	27 33 64
Unslashed Zero	ESC ! A	27 33 65
Double Height On	ESC US 1	27 31 49
Double Height Off	ESC US 0	27 31 48
Double Width Printing	US	31

<i>Oki Command</i>	<i>ASCII</i>	<i>Decimal</i>
Emphasized Printing On	ESC T	27 84
Emphasized Printing Off	ESC I	27 73
Enhanced Printing On	ESC H	27 72
Enhanced Printing Off	ESC I	27 73
Form Feed	FF	12
Horizontal Tab, Execute	HT	9
Italic On	ESC ! /	27 33 47
Italic Off	ESC ! *	27 33 42
Line Feed Commands		
w/ Carriage Return	LF	10
w/o Carriage Return	ESC DC2	27 18
n/144" (n = 0 to 127)	ESC % 5 n	27 37 53 n
Reverse	ESC LF	27 10
Line Spacing		
Set Spacing to 1/6"	ESC 6	27 54
Set Spacing to 1/8"	ESC 8	27 56
Set Spacing, in n/144" (n = 0 to 127)	ESC % 9 n	27 37 57 n
Skip Over Perforation		
1/3" increments (n = 1 to 9)	ESC G n n	27 71 n n
Default	ESC % S 0	27 37 83 48

## Oki MICROLINE Standard Commands (continued)

<i>Oki Command</i>	<i>ASCII</i>	<i>Decimal</i>
Paper Out Sensor Off	ESC E 1	27 69 49
Paper Out Sensor On	ESC E 0	27 69 48
Print Quality		
Select HSD/SSD	ESC # 0	27 35 48
Select NLQ Courier	ESC 1	27 49
Select NLQ Gothic	ESC 3	27 51
Select Utility	ESC 0	27 48
Print Speed, Set to Full	ESC >	27 62
Print Speed, Set to Half	ESC <	27 60
Print Suppress On	DC3	19
Print Suppress Off	DC1	17
Proportional Printing		
On	ESC Y	27 89
Off	ESC Z	27 90
Reset: Clear Print Buffer	CAN	24
Shift-In	SI	15
Shift-Out	SO	14
Software I-Prime	ESC } NUL	27 125 0

<i>Oki Command</i>	<i>ASCII</i>	<i>Decimal</i>
Subscript Printing On	ESC L	27 76
Subscript Printing Off	ESC M	27 77
Superscript Printing On	ESC J	27 74
Superscript Printing Off	ESC K	27 75
Underline Printing On	ESC C	27 67
Underline Printing Off	ESC D	27 68
Uni-Directional Print On	ESC -	27 45
Uni-Directional Print Off	ESC =	27 61
Vertical Tab, Execute	VT	11



# Appendix C: Specifications

*Note: Specifications are subject to change without notice.*

## Print Method

Impact dot matrix

## Printhead

18 pins, 0.30 mm (0.012") diameter, with thermal protection

## Interfaces

*Standard:* Bi-directional parallel, IEEE-1284 compliant, USB 2.0

*Optional:* RS-232C Serial

## Receive Buffer Size

Maximum 128K

## Printhead Life

400 million characters average in 10 cpi utility mode at 25% duty and 35% page density

## Reliability

### Ribbon Life

ML620: approx. 8 million characters (Utility Mode)

ML621: approx. 13 million characters (Utility Mode)

### Emulations (co-resident)

- IBM Proprinter III
- Epson FX
- Oki MICROLINE Standard

## Physical Specifications

*Note: Height dimensions do not include the acoustic cover.*

### ML620

Size (WxDxH): 16.3 x 12.6 x 6.26"  
(414 x 320 x 159 mm)

Weight: 16.4 lb. (7.5 kg)

### ML621

Size (WxDxH): 22.36 x 12.6 x 6.26"  
(568 x 320 x 159 mm)

Weight: 21.5 lb. (9.8 kg)

## Print Speed

<i>Print Mode</i>	<i>Character Pitch</i>				
	<b>10 cpi</b>	<b>12 cpi</b>	<b>15 cpi</b>	<b>17.1 cpi</b>	<b>20 cpi</b>
<b>SSD</b>	—	700 cps	—	—	—
<b>HSD</b>	600 cps	600 cps	600 cps	600 cps	600 cps
<b>Utility</b>	450 cps	450 cps	450 cps	431 cps	450 cps
<b>NLQ</b>	113 cps	113 cps	113 cps	108 cps	108 cps

\* cps = Characters Per Second

## Characters per Line (cpl)

<i>Setting</i>	<i>ML620</i>	<i>ML621</i>
10 cpi	80 cpl	136 cpl
12 cpi	96 cpl	163 cpl
15 cpi	120 cpl	204 cpl
17.1 cpi	137 cpl	233 cpl
20 cpi	160 cpl	272 cpl

## Graphics Resolution

<i>Emulation</i>	<i>Density</i>	<i>Max. Resolution (Dots per inch)</i>
IBM, Epson	Single	60 x 216 dpi
	Double	120 x 216 dpi
	Quadruple	240 x 216 dpi
Oki MICROLINE	Single	72 x 72 dpi
	Double	144 x 144 dpi
	Quadruple	288 x 144 dpi

## Resident Fonts

<i>Print Quality</i>	<i>Available Fonts</i>
Near Letter Quality (NLQ)	Courier, Gothic
Utility (Draft)	Gothic
High Speed Draft (HSD)	Gothic
Super Speed Draft (SSD)	Gothic

## Bar Codes

- Code 39
- UPC A, UPC E
- EAN 8, EAN 13
- Interleaved 2 of 5
- Code 128
- Postnet
- CODEBAR (NW7)
- Industrial 2 of 5
- Matrix 2 of 5

## Paper Thickness: Tractor Feed

Rear/Front Push Feed: 0.015" (0.36 mm) maximum

Rear/Front Pull Feed: 0.017" (0.44 mm) maximum

Bottom Feed: 0.019" (0.48 mm) max.

Requires optional push or pull tractor.

## Environmental Requirements

### Temperature

Operating: 41 to 95° F (5 to 35° C)

Storage: 14 to 122° F (-10 to 50° C)

### Humidity

Operating: 20 to 80% RH

Storage: 5 to 95% RH

## Electrical Requirements

- 120 V model:
  - 100 VAC -10% to 127 VAC +10%
  - 50 or 60 Hz ( $\pm 2\%$ )

### Power Consumption:

Printing: max. 59 W (ISO 10561 Letter, Draft, Range1)

Idle: max. 15 W

Sleep mode:

max. 1.5 W (with no option attached)

max. 3.7 W (with full options attached)

- 230 V model:
  - 220 VAC -10% to 240 VAC +10%
  - 50 or 60 Hz ( $\pm 2\%$ )

### Power Consumption:

Printing: max. 59 W (ISO 10561 Letter, Draft, Range1)

Idle: max. 15 W

Sleep mode:

max. 1.5 W (with no option attached)

max. 3.7 W (with full options attached)

## Paper Specifications

Paper	Size
<b>Cut Sheet Paper</b>	
Paper Width ML620	3.9 – 10.1" (99.1 – 256.5 mm)
ML621	3.9 – 16.5" (99.1 – 419.1 mm)
Paper Length	3.9 – 14.3" (99.1 – 363 mm)
Single-part weight	45 – 90 g/m <sup>2</sup>
Thickness	0.002 – 0.0055" (0.05 – 0.14 mm)
<i>NOTE: Multi-part cut sheet paper cannot be used.</i>	
<b>Continuous Paper</b>	
Paper Width ML620	3 – 10" (76.2 – 254 mm)
ML621	3 – 16" (76.2 – 406.4 mm)
Single-part weight	45 – 90 g/m <sup>2</sup>
Single-part Thickness	0.002 – 0.0049" (0.05 – 0.12 mm)
Multi-part weight	35 – 40 g/m <sup>2</sup>
Multi-part Thickness	0.015" (0.36 mm) total thickness
	0.019" (0.48 mm) total thickness bottom path only

Paper	Size
<b>Carbon-lined Paper/Pressure Sensitive Paper</b>	
Multi-part weight	35 – 40 g/m <sup>2</sup>
Number of copies	Rear and Front push feed: original plus 5 copies  Bottom pull feed: original plus 6 copies
Inter leaf paper weight	Multi-part weight 38 – 40 g/m <sup>2</sup> (carbon paper: 34 g/m <sup>2</sup> )
Number of copies	Rear and Front push feed: original plus 3 copies  Bottom pull feed: original plus 4 copies
<i>NOTE: Multiple-part paper should be fastened by spot-pasting or crimping on both sides, and should be free of wrinkles.</i>	