

HD Color Video Camera

Operating Instructions

Before operating the unit, please read this manual thoroughly and retain it for future reference.

SRG-120DS

Table of Contents

Overview

Features	3
How to Use This Operating Instructions...	3
System Configuration	4
Operating a Camera Using the Supplied Infrared Remote Commander.....	4
Operating a Camera Using the IP Remote Controller	4
Operating Multiple Cameras Using the IP Remote Controller	5
Operating Multiple Cameras Using Multiple IP Remote Controllers.....	6
Precautions for Preventing Access to the Camera by an Unintended Third Party.....	7

Adjusting and Setting with Menus

About On-Screen Menus	8
Main Menu.....	8
Setting Menus.....	8
Control Button Display Section	8
EXPOSURE Menu	9
WHITE BALANCE Menu.....	10
PICTURE Menu	11
PAN TILT ZOOM Menu.....	11
SYSTEM Menu	12
STATUS Menu.....	13

Operation Using the Supplied Infrared Remote Commander

Pan/Tilt and Zoom Operation	14
Panning and Tilting	14
Zooming	15
Operating Multiple Cameras with the Infrared Remote Commander.....	15
Adjusting the Camera	15
Focusing on a Subject.....	15
Shooting with Back Lighting.....	15
Storing the Camera Settings in Memory — the Presetting Feature	16

Appendix

Message List.....	18
Troubleshooting	19
Menu Configuration	20
Preset Items	22
License	23

Features

- The 1/2.8 type Exmor CMOS camera (utilising approximately 2 million valid pixels) allows for high-definition shooting with superior picture quality.
- 12x optical zoom with wide-range 71-degree horizontal angle zoom lens.
- By adopting its wide and dynamic range functions, you can see the optimised shooting image which incorporates bright and dark subjects at the same time.
- Adopts the industry standard RS-232 interface of VISCA camera protocol in external communication. Long distance remote operation available using RS-232.
- High-speed and low-noise pan/tilt functions support a variety of purposes.
- You can use the infrared remote commander to set the camera and also to select panning, tilting and zooming from the setting menu.
- You can store up to 16 kinds of camera direction and camera status into the camera. In the case of the infrared remote commander, 6 kinds can be stored.
- You can use the LAN cable for external communication. This will make system construction easier.
- The camera can be set for a variety of HD video formats and has a SDI video output terminal.

How to Use This Operating Instructions

This Operating Instructions explains how to operate the HD Color Video Camera from a computer via a network and from a remote controller (not supplied).

The Operating Instructions is designed to be read on the computer display.

This section gives tips on making the most of the Operating Instructions. Read it before you operate the camera.

Jumping to a related page

When you read the Operating Instructions on the computer display, you can click on a sentence to jump to a related page.

Printing the Operating Instructions

Depending on your system, certain displays or illustrations in the Operating Instructions, when printed out, may differ from those that appear on your screen.

Remote Controller

You can operate and set the camera by using the supplied infrared remote commander or the IP Remote Controller (optional accessory).

Installation Manual (printed matter)

The supplied Installation Manual describes the names and functions of parts and controls of the camera, connection examples, and how to set up the camera. Be sure to read the Installation Manual before hand.

System Configuration

This unit has various system configuration capabilities using optional products. This section describes typical system examples with the required components and the main usage of each system.

Operating a Camera Using the Supplied Infrared Remote Commander

What you can do with this system

To operate the camera readily from a short distance.

System configuration

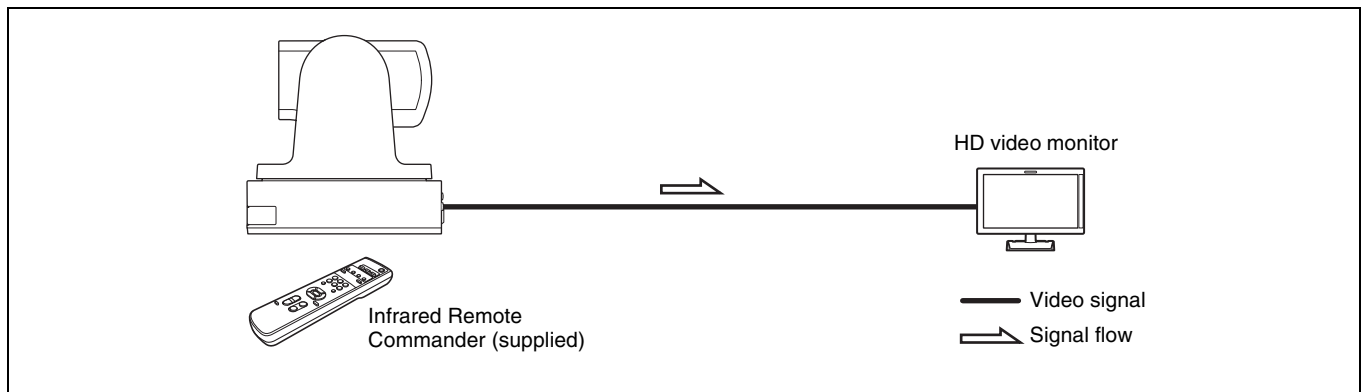

Operating a Camera Using the IP Remote Controller

What you can do with this system

To perform pan/tilt and zoom operations using the joystick of the IP remote controller, and to perform the Preset operation using the button.

System configuration

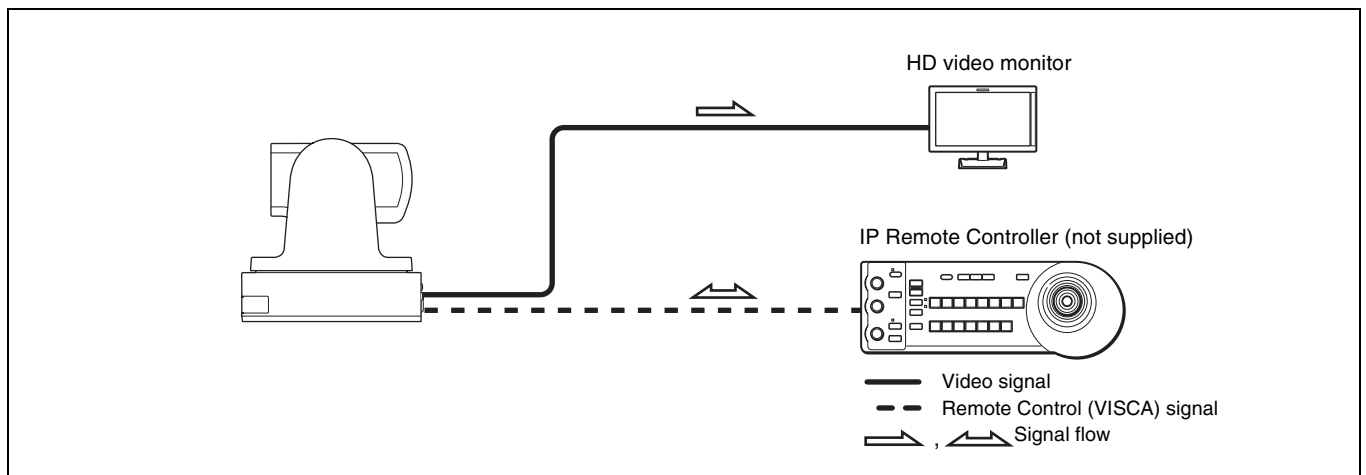

Note

Select the MODE selector of IP remote controller to position 0 (automatically selected) when using a combination of this unit and IP remote controller. For details, refer to the Operating Instructions of IP remote controller.

Operating Multiple Cameras Using the IP Remote Controller

What you can do with this system

You can operate up to 7 cameras with daisy chain connection using the IP remote controller (not supplied).

System Configuration

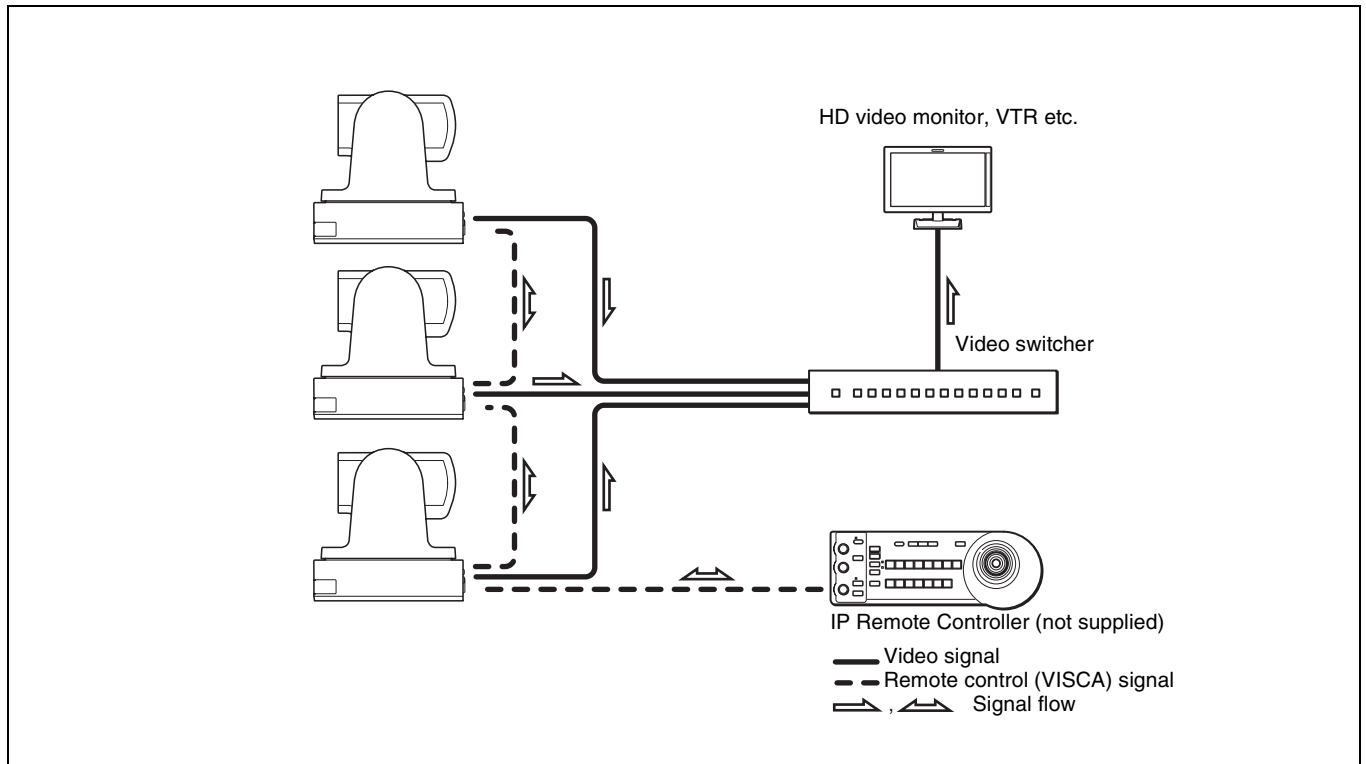

Notes

- Only RS-232 connection is available for VISCA CONTROL.
- You need to match the communication speed between the camera and the IP remote controller.
- You cannot use the RS-232 connections when using the LAN connection.

Operating Multiple Cameras Using Multiple IP Remote Controllers

What you can do with this system

- You can connect up to 112 cameras and five IP remote controllers.
- The joystick of the IP remote controller allows comfortable pan/tilt and zoom operations.

System configuration

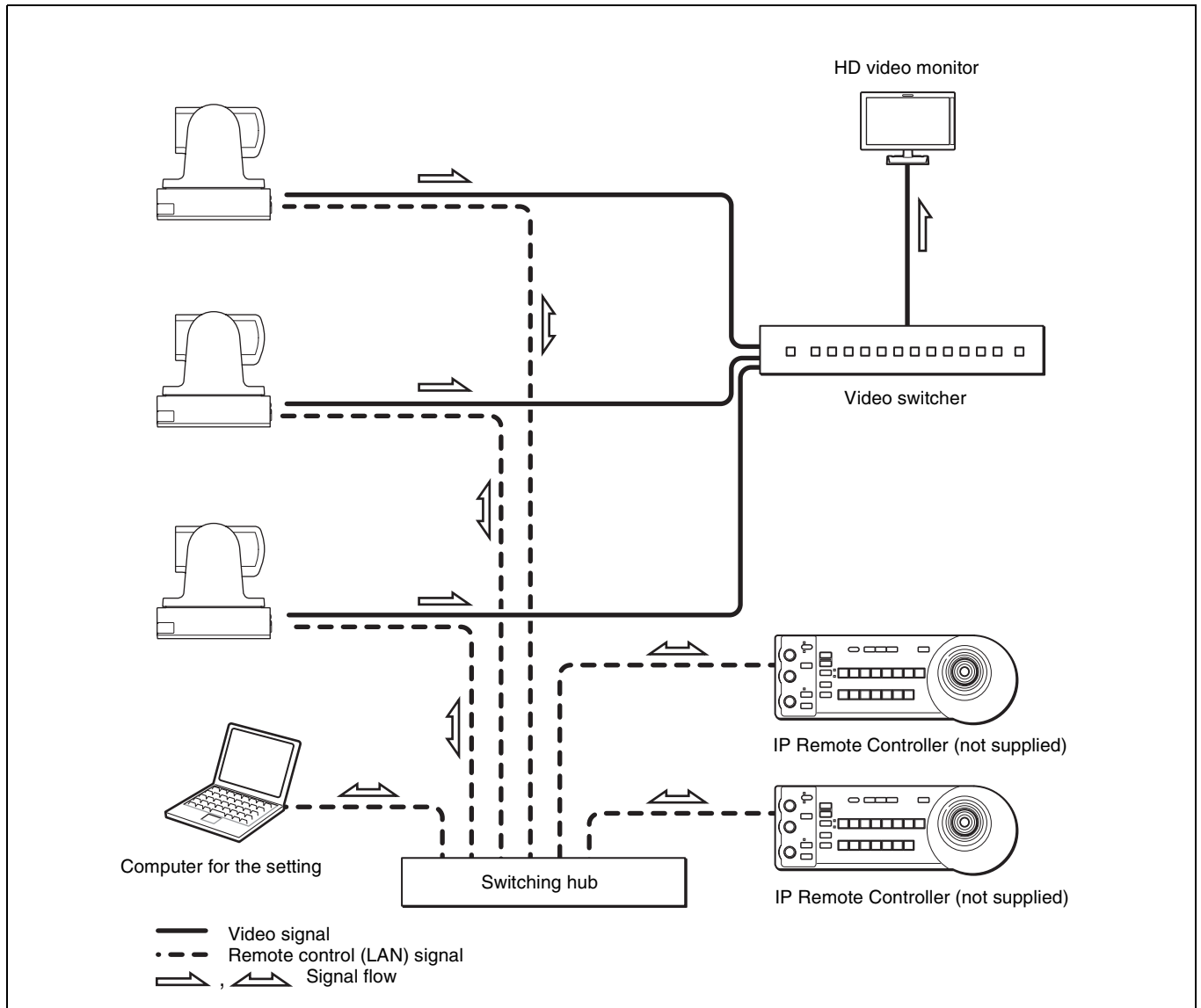

Note

You cannot use the RS-232 connections when using the LAN connection.

Precautions for Preventing Access to the Camera by an Unintended Third Party

The camera may be accessed by an unintended third party on the network (LAN or VISCA), depending on the usage environment. If the camera is accessed by an unintended third party, there may be undesired effects such as operations or settings that may interfere with viewing. The camera can be fraudulently accessed in a network environment where a device is connected or connectable to the network without the administrator's permission, or a PC or other network device connected to the network can be used without any permission. Connect to these environments at your own risk.

Adjusting and Setting with Menus

About On-Screen Menus

You can change various settings, such as shooting conditions and system setup of the camera, while observing menus displayed on a connected computer screen.

This section explains how to read the on-screen menus before starting menu operations.

For the overall menu configurations, see “Menu Configuration” (page 20).

Note

You cannot perform pan/tilt operations while the menu is displayed.

Main Menu

To display the main menu, press the DATA SCREEN button on the supplied infrared remote commander.

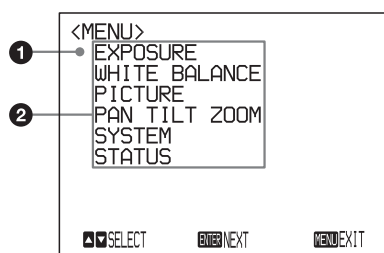

1 Selected item

Selects a setting menu.

The selected item is shown by the cursor. The cursor moves up or down by pressing the \uparrow or \downarrow button on the infrared remote commander.

2 Menu items

To display a setting menu, select one using the \uparrow or \downarrow button on the infrared remote commander and press the HOME button on the infrared remote commander.

Setting Menus

The setting menu selected on the main menu is displayed.

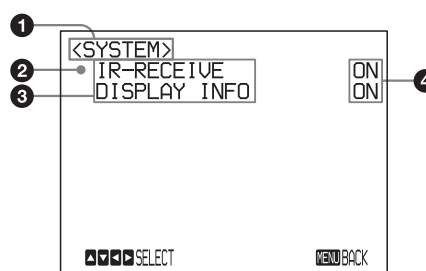

1 Setting menu

The name of the setting menu currently selected is displayed here.

2 Selected item

Selects a setting item.

The selected item is shown by the cursor.

Move the cursor up or down by pressing the \uparrow or \downarrow button on the infrared remote commander.

3 Setting items

The setting items for this setting menu are displayed.

Select the setting item using the \uparrow or \downarrow button on the infrared remote commander.

4 Set value

The currently set values are displayed.

To change a set value, use the \leftarrow or \rightarrow button on the infrared remote commander.

For the default value of each setting item, see “Menu Configuration” (page 20).

Control Button Display Section

Names of buttons displayed on the monitor are different from buttons on the infrared remote commander to be used.

Use the proper buttons on the infrared remote commander, referring to the following pictures.

Main menu

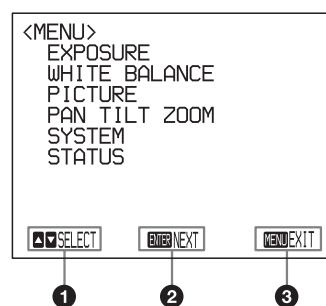

- ❶ Indicates that you can select a menu item by \uparrow or \downarrow button on the infrared remote commander. The selected item is shown by the cursor.
- ❷ Indicates that you can move to the next layer by pressing the HOME button.
- ❸ Indicates that you can return to the normal display by pressing the DATA SCREEN button.

Setting menu

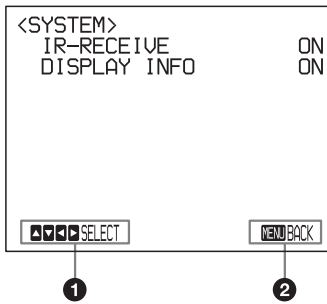

- ❶ Indicates that you can select the setting item by using the \uparrow or \downarrow button and you can change the set value by using the \leftarrow or \rightarrow button.
- ❷ Indicates that you can return to the main menu by pressing the DATA SCREEN button.

Note

When you are operating the menu using the supplied infrared remote commander, you cannot set IR-RECEIVE in the SYSTEM menu to OFF. To set IR-RECEIVE to OFF, use the appropriate VISCA command.

For detailed information on how to connect and VISCA command list, refer to the Technical Manual of the camera. For details on obtaining a Technical Manual, consult your Sony dealer.

EXPOSURE Menu

The EXPOSURE menu is used to set the items related to the exposure.

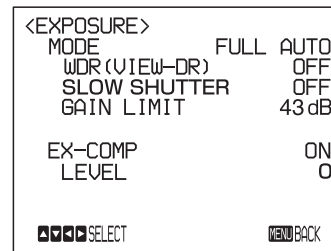

MODE (exposure mode)

FULL AUTO: The exposure is adjusted automatically using the sensitivity, electronic shutter speed, and iris.

BRIGHT: Adjust the brightness level (LEVEL) manually.

SHUTTER PRI: Shutter Priority mode. The exposure is adjusted automatically using the sensitivity and iris. Adjust the electronic shutter speed (SPEED) manually.

IRIS PRI: Iris Priority mode. The exposure is adjusted automatically using the sensitivity and electronic shutter speed. Adjust the iris (IRIS) manually.

MANUAL: Adjust the sensitivity (GAIN), electronic shutter speed (SPEED) and iris (IRIS) manually.

When you select one from among the various exposure modes, some of the following setting items that are required for the selected mode appear.

GAIN: Select the gain from among the following:

0, 3, 6, 9, 12, 15, 18, 21, 24, 27, 30, 33, 36, 39, 43 dB

SPEED: Select the electronic shutter speed from among the following:

For the 59.94/29.97 video format:

1/1, 1/2, 1/4, 1/8, 1/15, 1/30,
1/60, 1/90, 1/100, 1/125, 1/180, 1/250,
1/350, 1/500, 1/725, 1/1000, 1/1500,
1/2000, 1/3000, 1/4000, 1/6000,
1/10000 sec.

For the 50/25 video format:

1/1, 1/2, 1/3, 1/6, 1/12, 1/25,
1/50, 1/75, 1/100, 1/120, 1/150, 1/215,
1/300, 1/425, 1/600, 1/1000, 1/1250,
1/1750, 1/2500, 1/3500, 1/6000,
1/10000 sec.

IRIS: Select the iris from among the following:

CLOSE, F14, F11, F9.6, F8.0, F6.8, F5.6, F4.8, F4.0,
F3.4, F2.8, F2.4, F2.0, F1.8

LEVEL: Select the brightness level from among 0, 5 to 31.

WDR (VIEW-DR) (Wide dynamic range mode):

When MODE (exposure mode) is set to FULL AUTO, the camera distinguishes light and dark areas in the same scene, adjusts the brightness for dark areas, and also controls the blown out highlights. You can select the wide dynamic range mode from among OFF, LOW, MID and HIGH.

Notes

- You can set the wide dynamic range mode when WDR (VIEW-DR) is set to FULL AUTO only.
- When WDR (VIEW-DR) is not set to OFF, the MODE setting is fixed at FULL AUTO.
- When changing WDR (VIEW-DR), a change in screen luminance occurs for a moment.
- When the change of exposure is big, the screen may stop for a moment.

GAIN LIMIT: Select the upper limit of the gain rise in FULL AUTO, SHUTTER PRI and IRIS PRI modes. Select from among 9, 12, 15, 18, 21, 24, 27, 30, 33, 36, 39, 43 dB.

EX-COMP (exposure compensation)

When MODE is set to one of FULL AUTO, SHUTTER PRI or IRIS PRI, set this item to ON to enable exposure compensation. When you set EX-COMP to ON, LEVEL appears and you can select the exposure compensation level from among the following:

-7, -6, -5, -4, -3, -2, -1, 0, +1, +2, +3, +4, +5, +6, +7
If you set the level to 0, exposure compensation will be disabled. Level +7 is the brightest and -7 is the darkest compensation value.

When EX-COMP is set to OFF, exposure compensation does not function.

SLOW SHUTTER

When you set the mode to ON, the camera automatically uses slow shutter speed for exposure as the illumination of the object to be shot decreases. This mode is only available when AE mode is set to FULL AUTO.

WHITE BALANCE Menu

The WHITE BALANCE menu is used to select the white balance mode.

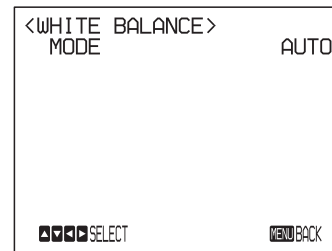

MODE (white balance mode)

Select the white balance mode from among the following: AUTO, IN DOOR, OUT DOOR, ONE PUSH, ATW (Auto Tracing White Balance), MANUAL. When you select MANUAL, R.GAIN (red gain) and B. GAIN (blue gain) appear. You can select each item in the range from -128 to 127.

When you select the ONE PUSH mode

Perform the following operations.

- 1 Zoom in on a white subject in the center of the screen.
- 2 Press the HOME button of the supplied infrared remote commander.

The one-push white balance adjustment is activated.

When DISPLAY INFO (page 12) is set to ON in the SYSTEM menu, the white balance adjustment result is displayed on the monitor.

PICTURE Menu

The PICTURE menu is used to set the items related to the picture.

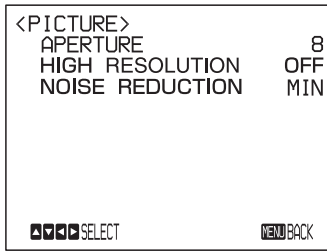

APERTURE (aperture compensation)

Select the aperture compensation level from among MIN, 1 to 14 and MAX.

HIGH RESOLUTION

You can set this mode to ON or OFF. When set to ON, you can enjoy emphasised edge and high-resolution images.

NOISE REDUCTION

You can enjoy clearer images by removing unnecessary noise (fixed pattern and randomised noise). You can select 6 levels from OFF (MIN), 1 to 5 (MAX).

PAN TILT ZOOM Menu

The PAN TILT ZOOM menu is used to select the pan/tilt/zoom mode.

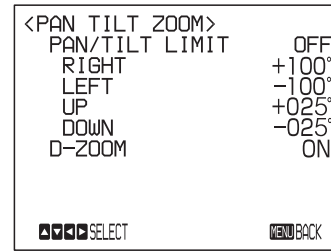

PAN/TILT LIMIT

When you set PAN/TILT LIMIT to ON, you can select the limit of pan/tilt operation.

You can select the following values:

RIGHT: +100° to -99°, selectable in 1° steps.

LEFT: +99° to -100°, selectable in 1° steps.

UP: +25° to -24°, selectable in 1° steps.

DOWN: +24° to -25°, selectable in 1° steps.

Note

The indicated value is changed when the ◀ or ▶ button is released. When the pan/tilt function is in motion, the indicated value does not change.

Setting the range of LEFT/RIGHT movement

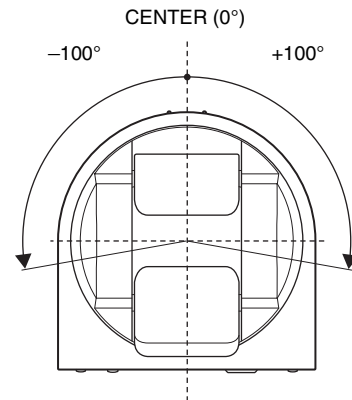

Note

The limit of pan/tilt operation becomes effective promptly after you set the range of PAN/TILT LIMIT. When you want to make the camera start with the ranges set, before turning off the power, store those values in POSITION 1.

For details, see “Storing the Camera Settings in Memory — the Presetting Feature” (page 16).

Setting the range of UP/DOWN movement

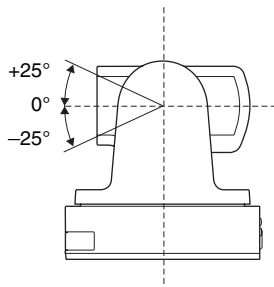

Note

When you turn the camera to the right or left beyond the 90° with the camera pointed downward by 25°, the camera may be caught on the lens, depending on the zoom position of the lens.

D-ZOOM (digital zoom)

You can set digital zoom to ON or OFF. When set to OFF, digital zoom does not operate, and only optical zoom is available. When set to ON, digital zoom takes over after optical zoom reaches MAX (12×). Up to 144× can be zoomed digitally.

When digital zoom is available, the resolution decreases.

SYSTEM Menu

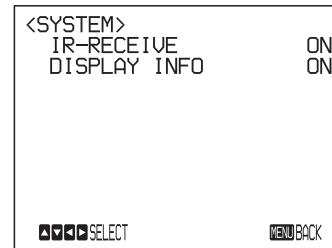

IR-RECEIVE (infrared signal reception)

When this is set to OFF, the camera does not receive the signal from the supplied infrared remote commander.

Be sure to keep it set to ON when you use the supplied infrared remote commander.

Note

You cannot set IR-RECEIVE to OFF when you operate the menu using the supplied infrared remote commander. To set it to OFF, use the appropriate VISCA command.

DISPLAY INFO

When this item is set to ON, the message automatically appears for about 3 seconds on the monitor screen, when you perform the following operations using the supplied infrared remote commander.

Message	Remote control operation
PRESET n: OK "n" is a preset position number of the infrared remote commander, between 1 and 6.	You have stored the camera settings to POSITION 1 to 6.
RECALL n: OK "n" is a preset position number of the infrared remote commander, between 1 and 6.	You have read the camera settings stored in POSITION 1 to 6.
RESET n: OK "n" is a preset position number of the infrared remote commander, between 1 and 6.	You have reset the camera settings stored in POSITION 1 to 6 to the default settings.
ONE PUSH WB: OP	During the white balance adjustment in the ONE PUSH white balance mode, the message blinks on the screen.
ONE PUSH WB: OK	When white balance adjustment is correctly performed in ONE PUSH white balance mode, this message appears on the screen.
ONE PUSH WB: NG	If white balance adjustment is incorrectly performed in ONE PUSH white balance mode, this message flashes on the screen.

Notes

- The operations in the VISCA CONTROL and LAN connection are from n: 1 to 16.
- To keep the settings even after restarting the camera, store the camera settings to PRESET1.

STATUS Menu

The STATUS menu is used to display the settings selected with the menus.

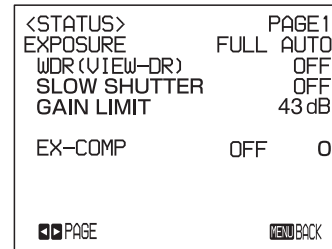

The STATUS menu consists of PAGE1 to PAGE5. This menu only displays the current menu settings, and you cannot change them with this menu.

PAGE1: Shows the settings selected with the EXPOSURE menu.

PAGE2: Shows the settings selected with the PICTURE menu and the WHITE BALANCE menu.

PAGE3: Shows the settings selected with the PAN TILT ZOOM menu.

PAGE4: Shows the settings selected with the SYSTEM menu, supplied infrared remote commander channel, VISCA communication baud rate, and Video latency setting.

PAGE5: Shows the settings selected with the LAN connection with IP address, Subnet mask and MAC address (shows the settings when the BOTTOM switch is set to LAN only).

Note

The VISCA communication baud rate for the camera is displayed. Even if you change the settings by using the SYSTEM SELECT switch and the BOTTOM switch after turning on the power, those settings are ignored and are not changed on the display.

Operation Using the Supplied Infrared Remote Commander

Pan/Tilt and Zoom Operation

Panning and Tilting

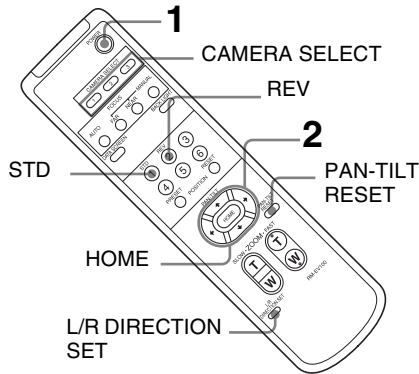

1 Press the POWER switch.

The camera will turn on and perform the pan/tilt reset operation automatically.

2 Press the arrow button to pan or tilt the camera.

While checking the picture on the screen, press the desired arrow button.

To move the camera little by little, press the button just for a moment.

To move the camera in a wide range, press and hold the button.

To move the camera diagonally, press the ◀ or ▶ button while holding down the ▲ or ▼ button.

To face the camera back to the front

Press the HOME button.

If the camera moves in a different direction from the one you intended

The camera is preset so that the image output from the camera is rotated toward the right whenever you press the ▶ button.

To face the camera toward the opposite direction

You might wish to face the camera toward the opposite direction from that of the button you pressed, for example, when you change the direction of the camera while checking the picture on the screen. In such a case, press the 2 (REV) button while holding down the L/R DIRECTION SET button.

Arrow button	Movement of the camera	Setting
		L/R DIRECTION SET While holding down REV 2 Press

To reset the setting

To reset the setting, press the 1 (STD) button while holding down the L/R DIRECTION SET button.

Arrow button	Movement of the camera	Setting
		L/R DIRECTION SET While holding down STD 1 Press

Note

The setting above only changes the signal emitted from the infrared remote commander, and does not change the setting of the camera itself. Therefore, repeat the setting for each infrared remote commander if you are using more than one infrared remote commander.

When the STANDBY lamp is blinking

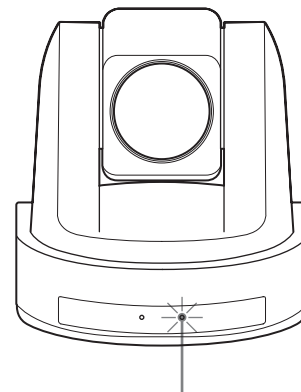

If the camera is moved forcibly, or a finger or other object interferes with camera movement, the camera may fail to memorize the pan/tilt position.

Press the PAN-TILT RESET button to reset the pan/tilt position.

Zooming

Press either of the ZOOM buttons.

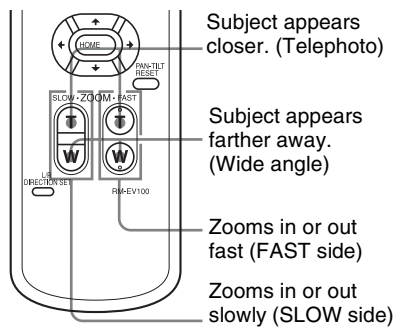

Note

When you perform pan/tilt operation while the camera is in the telephoto mode, the moving speed of the image on the screen may be a little jerky.

Operating Multiple Cameras with the Infrared Remote Commander

- 1 Set the IR SELECT switch on the rear of the camera you want to operate to 1, 2 or 3.



- 2 Press the CAMERA SELECT button on the infrared remote commander that corresponds to the number set in step 1.

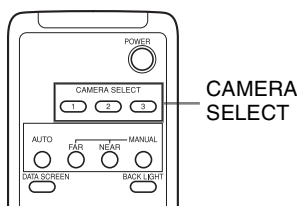

Then, you can operate the camera(s) specified by number. Every time you operate the camera(s) using the infrared remote commander, the CAMERA SELECT button pressed in step 2 lights.

Adjusting the Camera

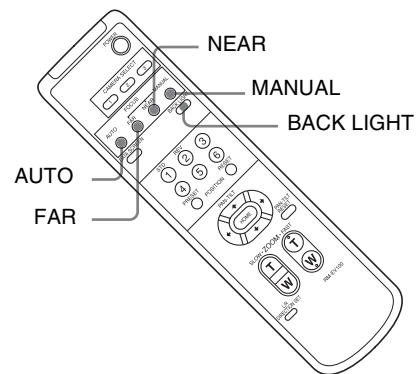

Focusing on a Subject

Focusing the camera on a subject automatically

Press the AUTO button. The camera focuses on the subject at the center of the screen automatically.

Focusing the camera on a subject manually

After pressing the MANUAL button, press either the FAR or the NEAR button to have the camera focus on the subject.

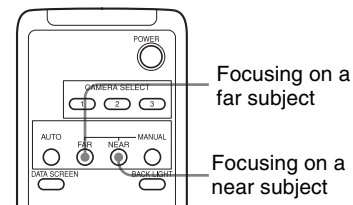

Shooting with Back Lighting

When you shoot a subject with a light source behind it, the subject becomes dark. In such a case, press the BACK LIGHT button.

To cancel the function, press the BACK LIGHT button again.

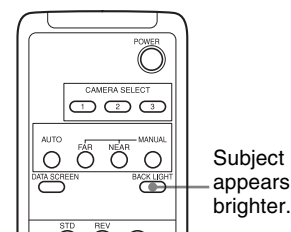

Note

The BACK LIGHT function is effective if MODE is set to FULL AUTO in the EXPOSURE menu of the camera.

Storing the Camera Settings in Memory — the Presetting Feature

Up to 16 combinations of settings (16 positions) including camera position, zooming, focusing, and backlighting, can be preset.

For details of the camera settings to be preset, see “Preset Items” (page 22).

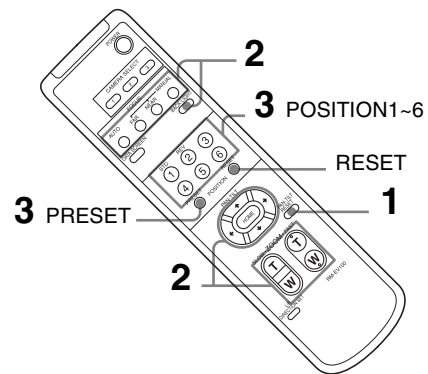

- 1** Press the PAN-TILT RESET button to reset the pan/tilt position.
- 2** Adjust the position, zooming, focusing and backlighting of the camera (pages 14 and 15).
- 3** While holding down the PRESET button, press any of the POSITION buttons, 1 to 6, in which you want to store the settings.

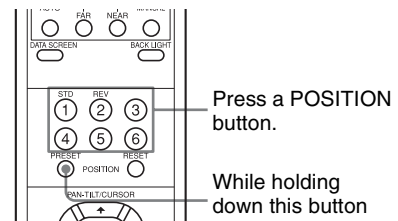

When you set DISPLAY INFO (page 12) to ON on the SYSTEM menu, the message “PRESET n : OK” automatically appears for about 3 seconds on the monitor screen.

Recalling the stored settings

Press any of the POSITION buttons, 1 to 6, in which you have stored the settings. The message “RECALL n:OK” automatically appears for about 3 seconds on the monitor screen.

Canceling the preset memory

While holding down the RESET button, press the POSITION button from which you want to cancel the settings.

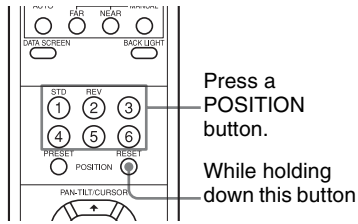

When you set DISPLAY INFO (page 12) to ON on the SYSTEM menu, the message “RESET n : OK” automatically appears for about 3 seconds on the monitor screen.

Notes

- When the power is turned on, the camera starts with the settings stored in POSITION 1.
- If you want to retain the previous pan and tilt positions, etc. before the power is turned off and turned on again, store those positions in POSITION 1.
- When you are storing or cancelling the settings in one POSITION, you cannot call up, store or cancel the settings in another POSITION.
- When the menu is displayed on the screen, you cannot perform the operation for storing, recalling, or cancelling the setting. Be sure to return to the normal display before starting these operations.

Message List

The following messages and indications may appear for this camera. Perform the following as necessary.

Lamp display

Lamp	Meaning and solution
When the power is turned on, the STANDBY lamp and POWER lamp are lit, flash together, or flash alternately.	The SYSTEM SELECT switch or the BOTTOM switch is not set correctly. Check the setting of each switch.
The STANDBY lamp is lit.	If the camera is moved forcibly, or a finger or other object interferes with camera movement, the camera's built-in processor may fail to memorize the pan/tilt position. Press the PAN-TILT RESET button of the infrared remote commander to reset the pan/tilt position.

Screen display

Message	Meaning and solution
PRESET n:OK (“n” is a preset position number between 1 and 16)	This message appears for about 3 seconds when you store camera settings to POSITION 1 to 16. The preset position number of the infrared remote commander is POSITION 1 to 6.
RECALL n:OK (“n” is a preset position number between 1 and 16)	This message appears for about 3 seconds when you read the camera settings stored in POSITION 1 to 16. The preset position number of the infrared remote commander is POSITION 1 to 6.
RESET n:OK (“n” is a reset position number between 1 and 16)	This message appears for about 3 seconds when you reset camera settings stored in POSITION 1 to 16. The preset position number of the infrared remote commander is POSITION 1 to 6.
ONE PUSH WB:OP	During the white balance adjustment in the ONE PUSH white balance mode, this message blinks on the screen.
ONE PUSH WB:OK	When the white balance adjustment has been done correctly in the ONE PUSH white balance mode, this message is lit on the screen.
ONE PUSH WB:NG	When the white balance adjustment has failed in the ONE PUSH white balance mode, this message blinks on the screen.

Troubleshooting

Before bringing in your camera for servicing, check the following as a guide for troubleshooting the problem. If the problem cannot be corrected, consult your Sony Service Center.

Symptom	Cause	Remedy
The power of the camera is not turned on.	The AC power adaptor is not connected to the DC 12 V connector firmly.	Insert the power cord firmly as far as it will go.
	The AC power cord is not inserted firmly into the AC power adaptor or the AC outlet.	Insert the power cord firmly as far as it will go.
	-	Pull out the plug of the power cord from the AC outlet, then reinsert it into the AC outlet after waiting a while.
Video is not displayed on the connected video monitor.	The video connection cable is not connected properly.	Make sure the connection between the video monitor and camera is made correctly.
	The exposure is not set correctly on the camera.	Set the exposure correctly on the EXPOSURE menu (page 9).
	The BOTTOM switch is not set correctly.	Check that the BOTTOM switches 2, 5, 6, 7 and 8 are set to OFF.
	The SYSTEM SELECT switch is not set properly.	Check the output format of the video on the camera and input format of video on the video monitor.
Pan or tilt cannot be operated.	A menu is displayed on the computer screen.	Press the DATA SCREEN button on the supplied infrared remote commander to remove the menu from the computer screen.
	The panning or tilting range is limited.	Change the PAN/TILT LIMIT setting on the PAN TILT ZOOM menu (page 11).
The EXPOSURE menu cannot be set except for FULL AUTO.	WDR (VIEW-DR) is not set to OFF.	After setting the WDR (VIEW-DR) to OFF, select the MODE of the EXPOSURE (page 9).
The infrared remote commander does not work.	The CAMERA SELECT button you pressed on the infrared remote commander does not match the number set with the IR SELECT switch on the camera.	Press the CAMERA SELECT button corresponding to the IR SELECT switch setting on the camera (page 15).
The VISCA CONTROL is not available with a computer connected to the camera.	The computer is not correctly connected to the camera.	Make sure the connection between the computer and camera is made correctly.
		Check that the BOTTOM switch on the bottom of the camera is set correctly.
		Check that the SYSTEM SELECT switch is set to a position in which video signals are output.
LAN communication is not available with a computer connected to the camera.	The computer is not correctly connected to the camera.	Make sure the connection between the computer and camera is made correctly.
		Check that the LAN (BOTTOM switch) is set to ON.
	The computer is not correctly set.	Check the precautions in the setting of the dedicated PC application.
The camera does not work when connected one-to-one to the IP remote controller.	A crossover cable is not used.	Use a crossover cable for one-to-one LAN connection.
The camera cannot be operated at all.	The SYSTEM SELECT switch on the rear of the camera is not set correctly.	Check that the SYSTEM SELECT switch is set to a position in which video signals are output.

Menu Configuration

The menus of the camera are configured as described below. For more details, refer to the pages in parentheses. The initial settings of each item are in bold.

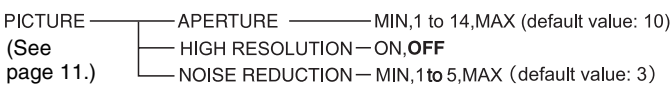
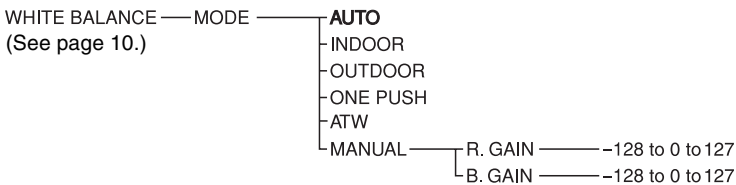
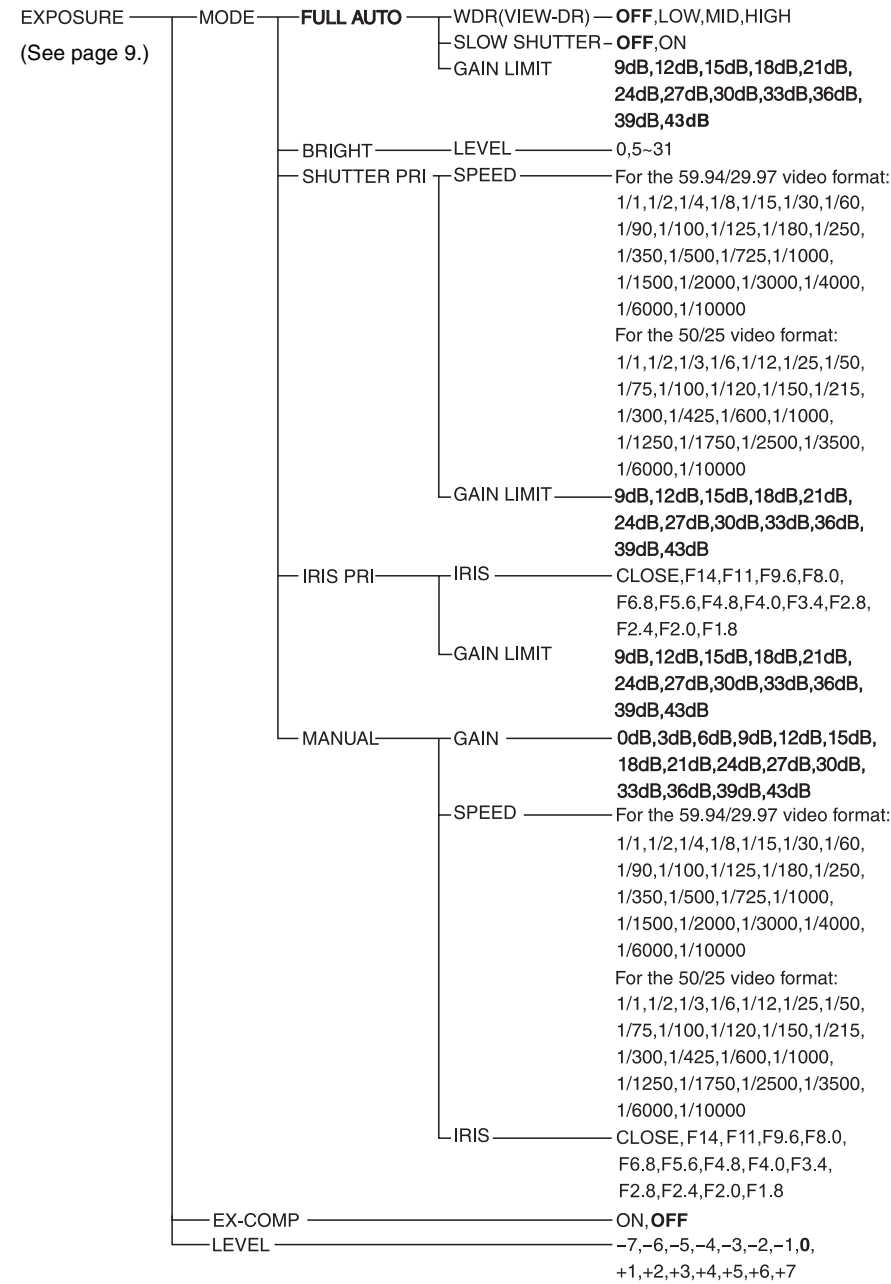

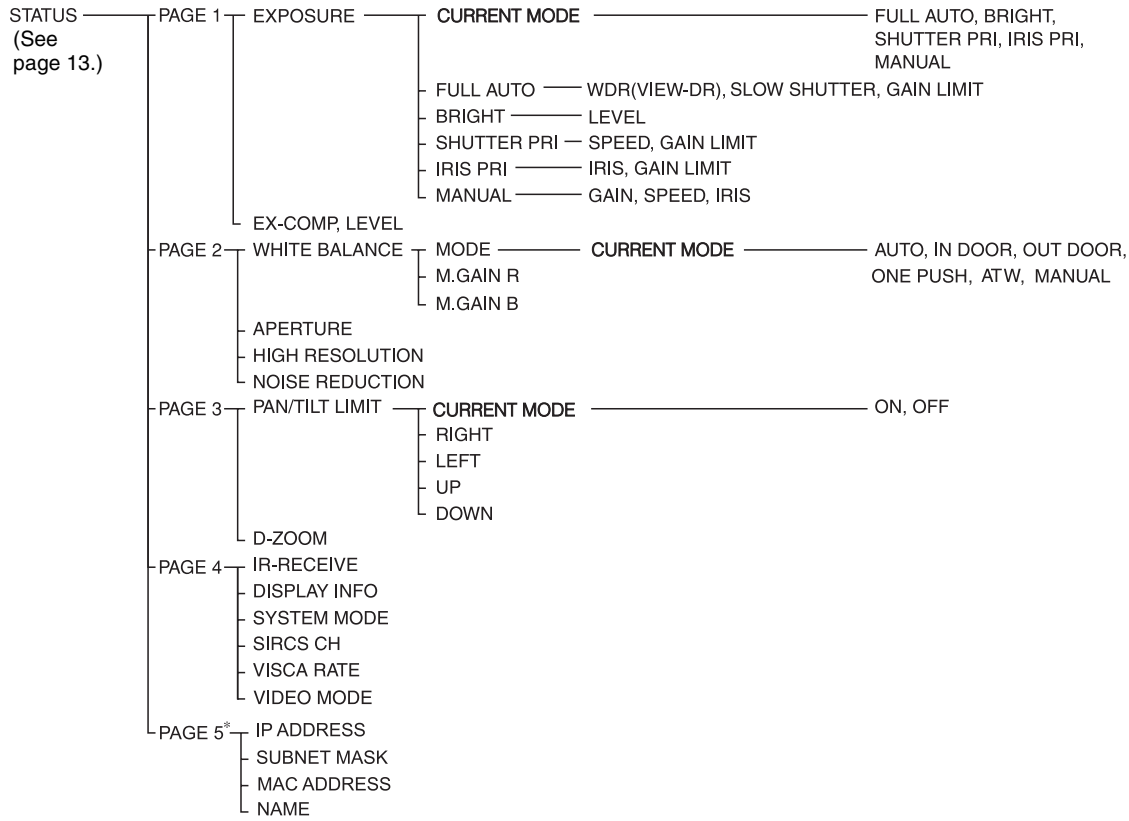
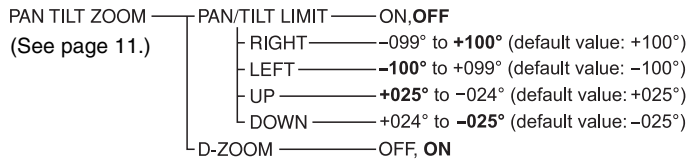

* PAGE 5: Shows the settings when the BOTTOM switch is set to LAN only.

Preset Items

The following items set by using the infrared remote commander and menu items can be stored in the memory of the camera.

Items adjusted with the infrared remote commander

Preset item	Preset position number	
	1	2 to 6
Pan/Tilt Position	●	○
Zoom Position	●	○
Focus Mode Auto/Manual	●	○
Focus Position	●	○
Backlight Compensation ON/OFF	●	○

Menu items

Preset item	Preset position number	
	1	2 to 6
EXPOSURE MODE	●	○
WDR(VIEW-DR)	●	○
SLOW SHUTTER	●	–
AE GAIN LIMIT	●	–
BRIGHT LEVEL	●	○
SPEED	●	○
IRIS	●	○
GAIN	●	○
EX-COMP ON/OFF	●	○
EX-COMP LEVEL	●	○
WHITE BALANCE MODE	●	○
ONE PUSH WB R/B Data	●	–
MANUAL R/B GAIN	●	○
APERTURE	●	○
HIGH RESOLUTION	●	○
NOISE REDUCTION	●	○
PAN/TILT LIMIT	●	–
D-ZOOM	●	○
DISPLAY INFO	●	–

● : Setting items retained in memory when the power is turned off and then on again. The camera starts with these settings stored in POSITION 1.

○ : Setting items retained in memory when the power is turned off and then on again.

– : Setting items cleared from the memory when the power is turned off and then on and reset to the initial settings.

For detailed information on POSITION 1, see “Storing the Camera Settings in Memory — the Presetting Feature” (page 16).

You can store the following items in the memory (POSITION 1), but you can set them only by using the appropriate VISCA command.

- Focus Near Limit
- IR Receive
- IR Receive Return

For detailed information on the VISCA command list, refer to the Technical Manual of the camera. For details on obtaining a Technical Manual, consult your Sony dealer.

The setting of preset numbers 1 to 16 are available for VISCA CONTROL and LAN connection.

License

This software partially supports component uIP.
Therefore the following license conditions apply.

Copyright (c) 2001-2006, Adam Dunkels and the
Swedish Institute of Computer Science All rights
reserved.

Redistribution and use in source and binary forms, with or
without modification, are permitted provided that the
following conditions are met:

1. Redistributions of source code must retain the above
copyright notice, this list of conditions and the
following disclaimer.
2. Redistributions in binary form must reproduce the
above copyright notice, this list of conditions and the
following disclaimer in the documentation and/or
other materials provided with the distribution.
3. The name of the author may not be used to endorse or
promote products derived from this software without
specific prior written permission.

THIS SOFTWARE IS PROVIDED BY THE AUTHOR
'AS IS' AND ANY EXPRESS OR IMPLIED
WARRANTIES, INCLUDING, BUT NOT LIMITED
TO, THE IMPLIED WARRANTIES OF
MERCHANTABILITY AND FITNESS FOR A
PARTICULAR PURPOSE ARE DISCLAIMED. IN NO
EVENT SHALL THE AUTHOR BE LIABLE FOR
ANY DIRECT, INDIRECT, INCIDENTAL, SPECIAL,
EXEMPLARY, OR CONSEQUENTIAL DAMAGES
(INCLUDING, BUT NOT LIMITED TO,
PROCUREMENT OF SUBSTITUTE GOODS OR
SERVICES; LOSS OF USE, DATA, OR PROFITS; OR
BUSINESS INTERRUPTION) HOWEVER CAUSED
AND ON ANY THEORY OF LIABILITY, WHETHER
IN CONTRACT, STRICT LIABILITY, OR TORT
(INCLUDING NEGLIGENCE OR OTHERWISE)
ARISING IN ANY WAY OUT OF THE USE OF THIS
SOFTWARE, EVEN IF ADVISED OF THE
POSSIBILITY OF SUCH DAMAGE.

<http://www.sony.net/>

Sony Corporation