

Manual



DLT-V6210 Industrial PC

Manual V1.01

IMPORTANT:

Read this manual carefully.

Keep for future reference.

The software and hardware designations as well as the brand names used in this documentation are in most cases also registered trademarks and are subject to the international law (trademark, brand and patent-protection laws).

Windows® is a registered trademark of Microsoft Corporation in the United States (US) and other countries.

RAM® and RAM Mount™ are both trademarks of National Products Inc., 1205 S. Orr Street, Seattle, WA 98108.

DLT-V6210 devices can be delivered with or without preinstalled software. For devices with preinstalled software observe the associated license agreements.

We recognize all national and international trademarks and product names.

We reserve the right to modify the contents of this manual at any time and without prior notice.

DLoG GmbH assumes no liability for technical inaccuracies, typographic errors or faults in this documentation. DLoG GmbH also assumes no liability for damages caused directly or indirectly by the delivery, performance or usage of this material.

This documentation is protected by copyright. No reproduction, also in excerpts, is permitted without the prior written permission of the DLoG GmbH.

Manual title:	DLT-V6210 Industrial PC, all model variants DLTV6210XXXXXXXXXXXXXXXXXX
Manual completed on:	05/12/2017
Manual PN:	2005621010
Manual Version:	V1.01

© Copyright 2017
By DLoG GmbH
All rights reserved

DLoG GmbH
Industriestraße 15
D-82110 Germering
Phone (+49) 89 / 41 11 91 0
Fax (+49) 89 / 41 11 91 - 900

info@advantech-dlog.com
www.advantech-dlog.com

Table of contents

1. AVAILABLE DLT-V6210 MANUALS	5
1.1. Design elements in the manual	6
2. FUNCTIONAL DESCRIPTION	7
2.1. Intended use	7
2.2. Mount, operate and service the device correctly	8
2.3. Warranty conditions	8
2.4. Functional overview	9
2.5. Device identification/name plate	10
3. TECHNICAL DATA	11
3.1. Environmental conditions	11
3.2. Projected-capacitive touchscreen (PCT)	11
3.3. Internal speaker, sound	12
3.4. Device dimensions	12
4. UNPACKING, TRANSPORT AND STORAGE	13
4.1. Unpacking	13
4.2. Transport	13
4.3. Storage	14
5. CONFIGURATION WITH MDEVICE	15
6. WI-FI CONFIGURATION	16
6.1. Electromagnetic radio frequency energy	17
6.2. Antenna solutions for use in Germany	17
7. MECHANICAL INSTALLATION	18
7.1. Safety notice – observe before installing	18
7.1.1. Correct installation location	18
7.1.2. Secure attachment	19
7.1.3. Handling the device	19
7.2. Recommended sequence for the mechanical installation	20
7.3. Attach the mounting with the VESA mounting hole pattern	21
8. ELECTRICAL INSTALLATION, CABLE CONNECTION, CABLE COVER	23
8.1. Safety notice – observe before connecting	23
8.1.1. Installing the disconnecting device	23
8.1.2. Installation of DLT-V6210 on vehicles	24
8.2. Preparations	25
8.2.1. Material required	25
8.2.2. Components	26
8.3. Inserting the cable grommet in the cable compartment	26
8.4. Power cable, grounding	27
8.4.1. Plugging in and screwing on the power supply cable	29
8.4.2. Securing the ground using ring tongue to the ground bolt	29
8.4.3. Securing the power supply cable to the strain relief rail	30
8.5. Connecting the USB, Ethernet and COM cables	31
8.5.1. USB cable	31
8.5.2. Ethernet cable	32
8.5.3. COM cable	33
8.6. Closing off unused cable compartment openings	33
8.7. Attaching the cable cover	34
8.8. Automatic shutdown – functional description	35
9. OPERATION	37
9.1. Switching DLT-V6210 on/off	37
9.2. Operating the touchscreen (PCT)	38
9.3. Front keys and LEDs	39
9.3.1. Overview	39
9.4. Operating states	39
10. EXTERNAL CONNECTORS	40
10.1. Connectors under the cable cover	40
10.1.1. Serial COM interface	40
10.1.2. USB	41
10.1.3. Network adapter (10/100/1000)	41
10.2. CFast slot under the antenna cap	42
10.3. Opening/closing the antenna cap	42
11. INTEGRATED POWER SUPPLY UNIT	43
11.1. DC voltage supply connection	44
11.2. DC Power supply cable	44
12. OPTIONAL EQUIPMENT	46
12.1. Integrated low profile Wi-Fi antenna (optional)	46
12.2. External Wi-Fi antenna, remote (optional)	47
12.3. Wi-Fi card (optional)	47
12.4. Keyboards and keyboard mounts (optional)	48
12.5. Scanner and scanner bracket (optional)	49
12.6. Touch stylus (optional)	49
12.7. USB recovery stick (optional)	49
13. MAINTENANCE	50
13.1. Regular checks and maintenance of the complete system	50
13.2. Cleaning the DLT-V6210	51
14. MALFUNCTIONS	52
15. REASONABLY FORESEEABLE MISUSE	53
16. GUIDELINES AND CERTIFICATES	54
16.1. Overview	54
16.1. EMC guideline	54
16.1.1. Shielded components	54
16.1.2. EMC EU	54
16.2. FCC USA/CAN	55
16.3. RED (Radio Equipment Directive) 2014/53/EU	57
16.4. CE marking	58
16.5. Taiwan BSMI screen warning	58
17. END-OF-LIFE DEVICE DISPOSAL	58
18. TECHNICAL CUSTOMER SUPPORT	59
19. RETURN SHIPMENT FORM	60
20. LIST OF FIGURES	61

1. Available DLT-V6210 manuals

	Contents	For target group	Availability
Safety instructions	Important information about protecting personnel and property	Skilled personnel	Printed, enclosed with the device
Quickstart Guide	First steps in commissioning, mechanical and electrical installation and mounting	Skilled personnel	
Mounting instructions for accessories	Mounting steps	Skilled personnel and trained users	Printed, enclosed with the respective accessories
Manual	Complete operating instructions	Skilled personnel	PDF file (Download Center at www.advantech-dlog.com)
MDevice description	Configuration tool for the DLT-V6210	Skilled personnel	

- ⇒ Pay attention to these manuals because they help avoid hazards, reduce repair costs and downtimes, and increase the reliability and service life of DLT-V6210.
- ⇒ Keep the manuals for future use.
- ⇒ Please contact DLoG GmbH if you require additional information or clarification. You can find the contact address in section *Technical customer support*.

Current manual versions



The latest versions of our manuals are available in our download center: www.advantech-dlog.com -> *Download* -> *Products*

Observe safety instructions



Please read and observe the “DLT-V6210 Safety Instructions” delivered enclosed with the product.

1.1. Design elements in the manual

Personal injury

Information with regard to personal injury is shown in this manual as follows (signal words for indicating risk level):



DANGER / WARNING / CAUTION

DANGER means that death or severe bodily injury will occur if this information is not observed.

WARNING means that death or severe bodily injury can occur if this information is not observed.

CAUTION means that slight bodily injury can occur if this information is not observed.

Physical damage

Information about physical damage is shown as follows:

NOTICE: Physical damage

Information about possible physical damage.

Tips for handling product and manual

Tips for handling product and manual are shown as follows:

TIP

Tips for using the product.



Note about additional information in manuals.

2. Functional description

2.1. Intended use

The DLT-V6210 Industrial PC is a data communication terminal for the usage in commercial environments (e.g. logistics, warehouse, manufacture site). Any other or additional usage beyond this shall be deemed as improper usage. The user / operator of DLT-V6210 is solely responsible for any resulting damage. This also applies to any unauthorized modifications made to this device.

The DLT-V6210 Industrial PC comes with an integrated Power Adapter with a voltage range from 9 to 60 VDC. It is specified with maximum current of 3.6 A and up to 50 °C operating temperature.

The DLT-V6210 Industrial PC:

- is not approved to be used in any EX zone (potential explosion hazard).
- is not approved to be used on ships.
- is not approved to be used in any life-support system or critical safety system where system malfunction can lead to direct or indirect endangerment of human life.

Indented use includes the following:

- The compliance with all safety instructions.
- The compliance with the approved environmental conditions and specifications for this device. See section 3.1 *Environmental conditions*.

Approved accessories

Only use accessories that have been tested and approved by Advantech-DLoG for the respective DLT-V6210. Otherwise, any DLoG GmbH warranty for this device will be void.

Requirements for safe operation

- Proper transportation and storage.
- Proper setup and use.
- Proper maintenance and service.
- Operation by trained personnel.

2.2. Mount, operate and service the device correctly

DLT-V6210 devices were designed and built according to modern technology and accepted safety regulations. However, the operation of DLT-V6210 can endanger personnel or third parties and cause damage to the device and other material assets when, for example, the device is

- installed incorrectly or configured improperly.
- operated by untrained or uninstructed personnel.
- improperly operated and maintained.
- not used as intended.

The owner/operator commitments with regards to safety (accident prevention regulations, occupational safety) are to be followed.



WARNING

Only skilled personnel are permitted to transport, store, commission, perform electrical connections and maintain the DLT-V6210.

Skilled personnel for the purpose of this manual are persons who are familiar with how to store, install, perform electrical connections, commission, and operate this product and have the corresponding qualifications for their activities, such as:

- Training or instruction in how to switch on and off, ground, and label power circuits and devices or systems in accordance with the current standards for safety equipment, as well as the required authorization.
- Training or instruction in how to maintain and use appropriate safety equipment in accordance with the current standards for safety equipment.
- Training in first aid.

Users of the DLT-V6210 must be trained by skilled personnel and instructed about the operation of the device.

2.3. Warranty conditions

For DLT-V6210 devices and accessories the Advantech-DLoG TOB regulations are valid (section *Liability for defects -> limitation period for claims*).

Find details on www.advantech-dlog.com.

LCD display

The LCD display of DLT-V6210 series fulfills the highest quality standards and was inspected for pixel defects. However, due to technological reasons pixel defects can occur.

This is not a malfunction; it is a part of the technical specifications.

2.4. Functional overview

DLT-V6210 front side



DLT-V6210 back side

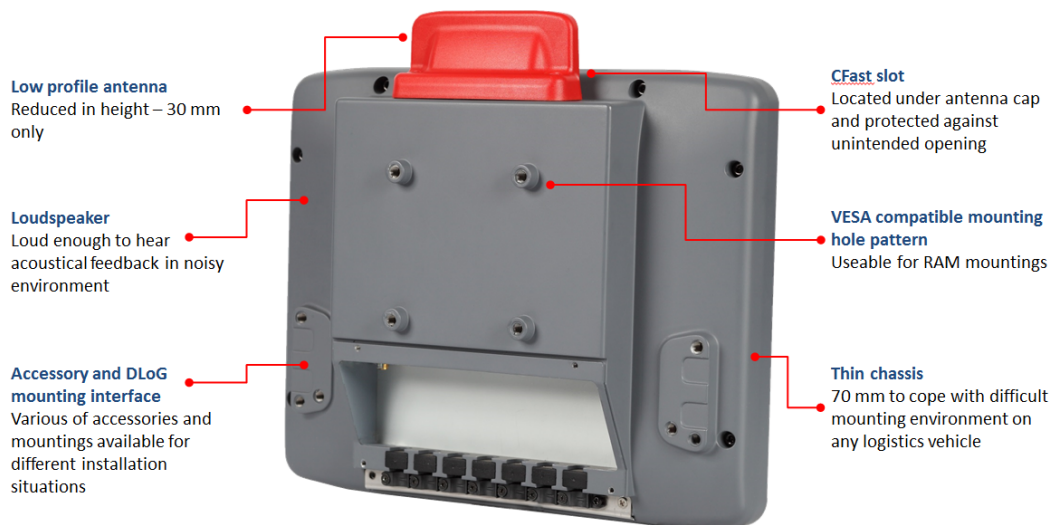

2.5. Device identification/name plate

The name plate is located on the rear side of DLT-V6210. It must remain legible at all times for the purpose of identifying the device.

⇒ Do not damage the name plate or remove it from the device.

The name plate contains product information required in case of Service & Repair activities.

Information about the name plate:

Information		Explanation	
DLoG GmbH		Manufacturer contact information	
Model	DLT-V6210	Device name	
	9-digit ID	Identification code (characters from left to right)	
		<i>Component</i>	<i>Explanation</i>
		9	Core processor 7 : x86 Bay Trail
		10	Front unit P : PCAP
		11	Storage L: 32G MLC CFast
		12	Power supply 1 : 12/24/48 VDC
		13	OS 0 : No OS 1 : Win 10 7 : WES7 E : WES8 P : Win 7 pro M : WEC7
		14	LTE 0 : No LTE/GPS
		15	WIFI 0 : No WIFI W : WIFI
		16	Revision number 0
		17	RoHS appliance E : RoHS
Input	V / A	Input voltage of DC power supply unit nominal current	
S/N		Serial number: Specific Advantech-DLoG device code	
Barcode		For Advantech-DLoG internal purposes	

Comment: X stands for not present / not applicable respectively as placeholder for add-ons.

Product IDs

FCC ID: M82-DLV6210

IC: 9404A-DLV6210

SW: V1.0

HW: V1.0

3. Technical data

- Processor: Baytrail E3825 @ 1.33 GHz Dual Core with 4GB DDR3, 32 GB CFAST
- Display: 10.4", XGA resolution with PCT touch (600 cd/m² / 1300 cd/m²)
- WLAN a/b/g/n, MIMO, diversity
- Low profile antenna
- External antenna single (RSMA), optional
- 2 x LAN RJ45 (10/100/1000)
- 1 x RS232 DSUB-9, 5 VDC on COM 1
- 2 x USB 2.0 Hi-Speed HOST A type, 5 VDC 500mA
- Loudspeaker integrated ~83 dbA
- Power supply: 12/24/48 V

3.1. Environmental conditions

Operating temperature	-30 to +50 °C Specification according to EN 60068-2-1/2
Storage temperature	-30 to +65 °C Specification according to EN 60068-2-1/2
Relative humidity	10% to 90% at 25 °C relative humidity Noncondensing Specification according to EN 60068-2-3
Mechanical vibration and shock resistance	Class 5M3 according to EN 60721-3-5 US Highway Truck according to MIL-STD 810F
IP protection class	IP65

3.2. Projected-capacitive touchscreen (PCT)

Technical data	
Type	Projected-capacitive touchscreen
Construction	Glass-film-film
Surface Hardness	9 H at 500 g according to JIS-K-5400:
Impact Energy Resistance	IK08 (5 joule) according to ECN62262
Mechanical properties	Chemically strengthened soda lime glass
Chemical resistance	Alcohols, Dilute Acids, Dilute Alkalis, Esters, Hydrocarbons, Ketones, Household Cleaning agents (according to DIN 42 115 PartIII)

3.3. Internal speaker, sound

DLT-V6210 is equipped with an internal speaker as standard (2 W).
The system messages from the industrial PC are output via this speaker.
The internal speaker can be configured in the audio settings of operating system in question.

3.4. Device dimensions

Fig. 3.1: Dimensions of DLT-V6210

Front view/Side view including antenna, dimensions in mm:

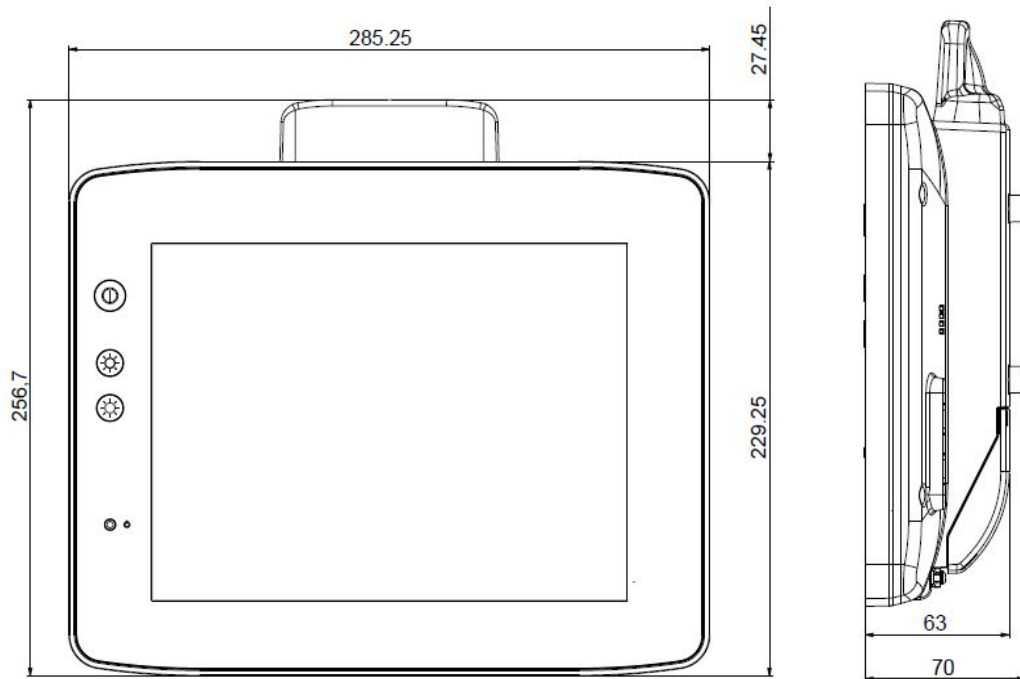

4. Unpacking, transport and storage

4.1. Unpacking

- ⇒ Open the packaging carefully to prevent damaging the device inside.
- ⇒ Save the packaging material (for possible forwarding transportation or return of DLT-V6210).
- ⇒ Check the shipment for completeness and any possible damage.
Delivery content depends on the ordered components.
- ⇒ Always keep the supplied manuals and documents, for example safety instructions and quick start guide.

4.2. Transport



WARNING

Risk of injury due to weight and sharp-edged parts.

DLT-V6210 can fall down and cause injuries due to its weight. The strain relief rail can have sharp edges and cause cutting injuries.

- ⇒ Always hold DLT-V6210 by the housing with both hands.
- ⇒ Never use the antenna cap as a handle. It can break due to the weight involved.
- ⇒ Do not hold DLT-V6210 by the strain relief rail.
- ⇒ Use the assistance of a second person for installation work.

If return/repacking is necessary

If DLT-V6210 is being returned to the manufacturer, a completely filled-out return shipment form must be enclosed with the device.

You can find this return shipment form:

- at the end of this manual
- and on the Internet at www.advantech-dlog.com

If you have to send the device back:

- ⇒ Use the ADLoG original packaging or another, suitable packaging material.
- ⇒ Use the specified, accompanying documents and package labels.

4.3. Storage

Temperature

Observe the permissible storage temperature range in the manual, section 3.1 *Environmental conditions*.

Touchscreen

NOTICE: Physical damage

Damage to the touchscreen due to incorrect storage.

- ⇒ Protect touchscreen from sharp edges, impacts, and heavy objects.
- ⇒ If stacking, do not stack higher than two devices.
- ⇒ Place devices front-to-front in this case.
The VESA mounting point on the rear side of the device can damage the touchscreen of another device.
- ⇒ Use protective material (non-flammable!) between the devices as precaution.

5. Configuration with MDevice

The **MDevice** software is used for configuring DLT-V6210 devices, for example:

- Power management
- Network settings
- Wi-Fi On/Off (no further Wi-Fi configuration; for configuring Wi-Fi, please use the appropriate MS-Windows tools in the system settings menu).



WARNING

Risk of injury and damage due to improper configuration.

These instructions are directed to skilled personnel.

- ⇒ Only qualified skilled personnel (e.g. IT personnel with good knowledge of PCs, operating systems and wireless networks) may configure DLT-V6210.

If DLT-V6210 is incorrectly configured, the DLoG GmbH warranty for this device will be void.

Start MDevice

- ⇒ Start **MDevice** via *Start -> Programs -> DLoG: MDevice*.
- ⇒ Enter the standard password: **gold**.



You can find details on configuration in the "MDevice Manual" at www.advantech-dlog.com.

6. Wi-Fi configuration

For configuring Wi-Fi, please use the appropriate MS-Windows tools in the system settings menu.



CAUTION

Radio wave emission.

Risks to health are possible due to excessive radio wave emission if the transmission power and the frequency are set incorrectly during the Wi-Fi configuration.

- ⇒ Observe the applicable regulations for your deployment location/country with regard to frequencies and the maximum permissible transmitting power.
Responsibility for this lies with the company who is operating DLT-V6210. The regulatory authorities in the relevant country can provide information on this.

Country-specific regulations

Example for Germany: In Germany according to regulations published in the gazette 89/2003 of the RegTP (regulating body for telecommunications and mail, now: "Bundesnetzagentur") - Federal Network Agency for electricity, gas, telecommunications, post and railway - the maximum permissible transmitting power, EIRP (Equivalent Isotropically Radiated Power), in the 2.4 GHz frequency band is set at 20 dBm (100 mw).

- ⇒ Set the transmitting power of the Advantech-DLoG antenna so that the permitted EIRP limit value is complied with.

Examples worldwide:

Region	Regulatory authority
EU	EU Verification Notified Body V1.8.1 ETSI
China	CNCA-07C-031
Japan	Japan SDoC, Certificate
Taiwan	Taiwan Certification
Canada	Canada Certification Body
USA	USA Certification
Brazil	Brazil Certification and Homologation
Russia	Russian Certification
Argentina	Argentinian Certification, CNC

6.1. Electromagnetic radio frequency energy



WARNING

Electromagnetic radio frequency energy can interfere with technical devices.

Some technical equipment in hospitals and aircraft is not shielded against radio frequency energy.

- ⇒ Do not use DLT-V6210 in aircraft or hospitals without receiving prior authorization. Usage in both occasions is only permitted if such authorization has been obtained.

DLT-V6210 industrial PCs can affect the functioning of implanted medical devices such as pacemakers and cause them to malfunction.

- ⇒ Do not use DLT-V6210 near pacemakers.
- ⇒ Always keep a distance of at least 20 cm between a pacemaker and DLT-V6210 to reduce the risk of interference.
- ⇒ Before using the device please obtain information about the use of the device within certain areas (e.g. airports, hospitals, etc.) and also about the respectively applicable regulations and obtain an approval for the operation of the device, if necessary.

6.2. Antenna solutions for use in Germany

The Advantech-DLoG antenna solutions are based on the prevailing IEEE 802.11 standard. This standard allows wireless data transfer at rates from 1 Mbps to 54 Mbps (300 Mbps if using IEEE 802.11n) using the 2.4 GHz and 5 GHz frequency band.

7. Mechanical installation

7.1. Safety notice – observe before installing



WARNING

Risk of injury and damage due to improper mechanical installation.

These mounting instructions are directed to skilled personnel.

- ⇒ Only qualified skilled personnel may perform the mechanical installation work on DLT-V6210.

If DLT-V6210 is incorrectly mounted, any DLoG GmbH warranty for this device will be void.

7.1.1. Correct installation location



WARNING

Risk of injury and damage due to improper deployment location.

- ⇒ Observe the intended use of DLT-V6210, e.g. not in potentially explosive areas, not in life-supporting facilities.
- ⇒ Ensure that the deployment location of DLT-V6210 complies with the permissible environmental conditions.

Risk of accident on the vehicle due to limited field of view of the user.

User's field of vision must remain free.

- ⇒ During installation, reserve sufficient space for DLT-V6210 and related accessories.
- ⇒ Make sure that the user's field of vision is not restricted in a prohibited way when mounting peripheral devices.

Radio wave emission in the vicinity of persons.

To ensure that the limits set for exposure to radio waves are not exceeded:

- ⇒ Install DLT-V6210 so that persons maintain a minimum distance of 20 cm to the antenna.

NOTICE: Physical damage

Installation environment without cooling air can overheat/damage DLT-V6210.

DLT-V6210 employs a passive cooling concept whereby the waste heat generated inside the device is emitted from the surface of the housing.

For this system to work/operate properly, sufficient fresh air circulation is required.

If there is no access to fresh cooling air, it may result in overheating and severe damage to the device.

Never install the system in a closed environment where the cooling air is unable to dissipate accumulated heat to the outside.

The maximum permissible ambient temperature for the entire system needs to be taken into account for the specific application area.

7.1.2. Secure attachment

Observe the following information about the mounting brackets:

- All brackets and mounting parts supplied by Advantech-DLoG are only intended to be used for attachment of the industrial PCs and the peripheral devices and may not be misused.
- Only use suitable mounting brackets and screws permitted by Advantech-DLoG.
- Ensure that ball-and-socket bases and mounting brackets are always attached correctly.



Please observe the mounting instructions supplied with the optional brackets.

7.1.3. Handling the device



WARNING

Hazardous voltage, electrical shock from contacting with live parts.

- ⇒ Do not put DLT-V6210 into operation if it is damaged.
- ⇒ Do not open or modify DLT-V6210.

Risk of injury due to weight and sharp-edged parts.

DLT-V6210 can fall down and cause injuries due to its weight. The strain relief rail can have sharp edges and cause cutting injuries.

- ⇒ Always hold DLT-V6210 by the housing with both hands.
- ⇒ Never use the antenna cap as a handle. It can break due to the weight involved.
- ⇒ Do not hold DLT-V6210 by the strain relief rail.
- ⇒ Use the assistance of a second person for installation work.

NOTICE: Physical damage

Damage and scratching of the touchscreen without transportation protective film.

The front display of DLT-V6210 is protected during transportation by a transparent film. This film should remain on the front display during assembly to avoid damage to the front display surface.

- ⇒ Only remove the film after all of the installation work has been completed.

7.2. Recommended sequence for the mechanical installation

Requirement: The installation location / vehicle must be prepared (e.g. connection to the ignition, correct voltage, etc.)

We recommend the following sequence for the installation:

1. Determine a suitable mounting position for DLT-V6210.
2. Secure device mounting at the vehicle/targeted object (RAM Mount etc.).
3. Connect external accessories to DLT-V6210.
4. Install an easily accessible disconnecting device, such as a switch close to the device.
5. Connect all cables.
6. Seal cable passages with cable grommets and dummy grommets.
7. Close DLT-V6210 with cable cover.
8. Mount DLT-V6210 on the device mounting bracket.

7.3. Attach the mounting with the VESA mounting hole pattern

The back of the DLT-V6210 has a VESA compatible 75 x 75 mm mounting hole pattern. It is used to attach VESA compatible mountings to mount the vehicle docking station at the deployment location.

ATTENTION: Physical damage

Only use mountings and fastening materials that have been tested and approved by Advantech-DLoG for the respective DLT- V6210. Otherwise, any DLoG GmbH warranty for this DLT-V6210 system will be void.

Fig. 7.1: Position VESA drill holes of DLT-V6210

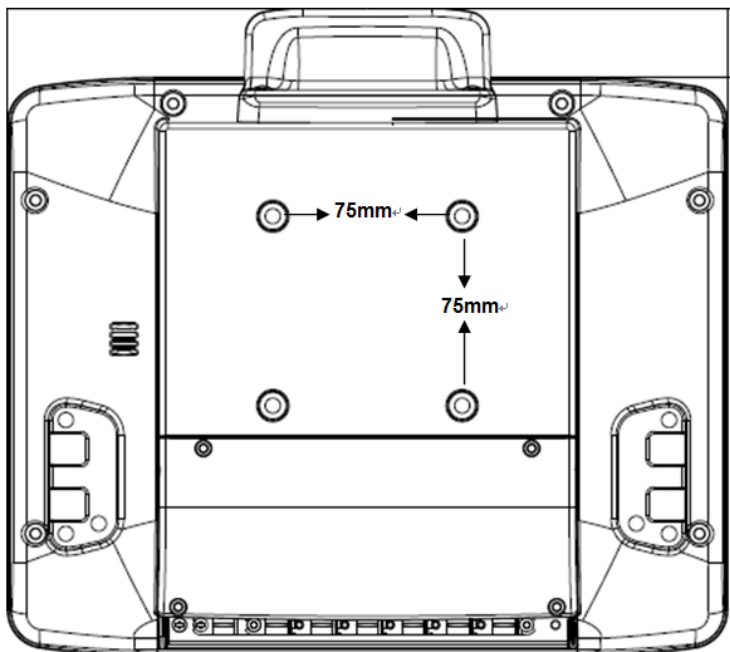

WARNING

Risk of accident during vehicle operation if the mounting of the V6210 becomes loose and breaks while driving.

Ensure the following when attaching the mounting on the VESA mounting hole pattern:

- **Specialty mechanical knowledge** is required for correct mounting!
- Use suitable fastening materials.
- Use suitable screws: Screws that are too long can penetrate the back of the vehicle docking station and cause irreparable damage. Screws that are too short do not provide secure mounting.
- Use suitable washers.
- Observe the maximum screw-in depth of the hole of the mounting hole pattern: The recommended screw-in depth of Dx1 always applies (screw diameter x 1).
- Advantech-DLoG mountings include suitable screws and washers. Please use them (see examples on next page).

Examples for RAM Mount Set mounting materials

RAM Mount Set short (arm length, 130 mm)	RAM Mount Set long (arm length 215 mm)
ADLoG order no: DL-CMEMT70129800	ADLoG order no: DL-CMEMT70129700
Fixing plate RAM-Mount VESA RAM conn. arm VESA 130mm Washer spring A6 DIN128 FSt galvan. Screw Cyl.int.hex DIN912 M6x16 V2A Washer ISO 8738 (DIN 1440)-A6-A2	Fixing plate RAM-Mount VESA w.ball 2.25" Holder VESA connect.arm 215mm ball 2.25" Screw Cyl.int.hex DIN912 M6x16 V2A Washer ISO 8738 (DIN 1440)-A6-A2 Washer spring A6 DIN128 FSt galvan.

8. Electrical installation, cable connection, cable cover

8.1. Safety notice – observe before connecting



WARNING

Risk of injury and damage due to improper electrical installation.

These instructions are directed to skilled personnel.

- ⇒ Only qualified skilled personnel are permitted to perform the electrical installation of DLT-V6210.
- ⇒ Comply with the appropriate national installation regulations for all cable routing.

8.1.1. Installing the disconnecting device



WARNING

Electrical shock due to lack of disconnecting device.

The DLT-V6210 industrial PC is not equipped with a switching apparatus accessible from outside to quickly disconnect the device from the power supply.

To enable the industrial PC to be quickly disconnected from the power supply in emergency situations:

- ⇒ Install an easily accessible disconnecting device such as an appropriate on-load switch for low voltage close to the industrial PC.
- ⇒ Make sure that the disconnecting device disconnects all power supply lines.

Deployment location in fueling stations, chemical plants.

The operation of electrical equipment at locations where flammable gases or vapors are present poses a safety hazard.

- ⇒ Turn off DLT-V6210 when you are near gas stations, fuel depots, chemical plants or places where blast might take place.

8.1.2. Installation of DLT-V6210 on vehicles



DANGER

Electrical shock due to insufficient EMERGENCY shut-off switch.

If the EMERGENCY-OFF switch of the vehicle does not switch off DLT-V6210, there is a risk of electrical shock.

- ⇒ Install DLT-V6210 and the EMERGENCY-OFF switch so that DLT-V6210 also switches off when the EMERGENCY-OFF switch is operated.

Risk of accident on the vehicle due to unexpected emergency stop because of electro conductive connection of DLT-V6210 to the vehicle chassis.

Due to a variety of technical properties of forklifts and forklift trucks, it can be necessary to electrically isolate DLT-V6210 from the chassis of the vehicle to prevent malfunctions.

The necessity of this must be studied on a case-by-case basis, however, it is recommended for vehicles with potential-free chassis.

- ⇒ For example, using rubber buffers ensures that the terminal has no electrically conducting connection to the chassis.
- ⇒ If peripheral equipment (such as scanners, printers, scales or similar) which has its own power supply unit to be used, you must ensure that the power supply units of these peripherals are galvanically separated from the supply of the targeted object. Moreover, the peripheral equipment and its cabling must be attached electrically isolated.
- ⇒ If external antennas are being used, you must ensure that the antennas are isolated at the mounting point on the vehicle chassis.

Risk of accident on the vehicle due to unstable attachment of DLT-V6210.

- ⇒ When installing DLT-V6210, make sure that no one will be injured if the bracket breaks (e.g. because of a stress fracture).
- ⇒ Alternatively you can put appropriate safety measures in place (e.g. install a security cable in addition to the mounting bracket).

NOTICE: Physical damage

Overvoltage on DLT-V6210 when charging the vehicle battery.

DLT-V6210 must be disconnected from the battery while the battery is being charged.

Or it must be ensured that the maximum permitted input voltage of DLT-V6210 is not exceeded.

8.2. Preparations

- ⇒ Lay out all cables which are ready to be connected to DLT-V6210.
- ⇒ Select the appropriate slot on the connector panel of DLT-V6210.
- ⇒ Check and test which order of the cables routing is the best to fit in the cable compartment.

Fig. 8.1: Cable compartment



8.2.1. Material required

Cable sealing set (scope of delivery: cable cover)

Fig. 8.2: Cable sealing set

Cable grommets (which openings have different sizes)	Dummy grommets	Cable clips	Mounting screws
			

NOTICE: The cable grommet must completely surround the cable.
The opening of the cable grommet must be slightly smaller than the cable diameter.
If the opening is too large or too small, the sealing of the device will not be ensured.

Tools

- Hexagon screwdriver , size 3
- Philips screwdriver, PH1
- Philips screwdriver, PH0
- Flat head screwdriver size 3
- Socket wrench, size 5
- Socket wrench, size 6
- Socket wrench, size 8

8.2.2. Components

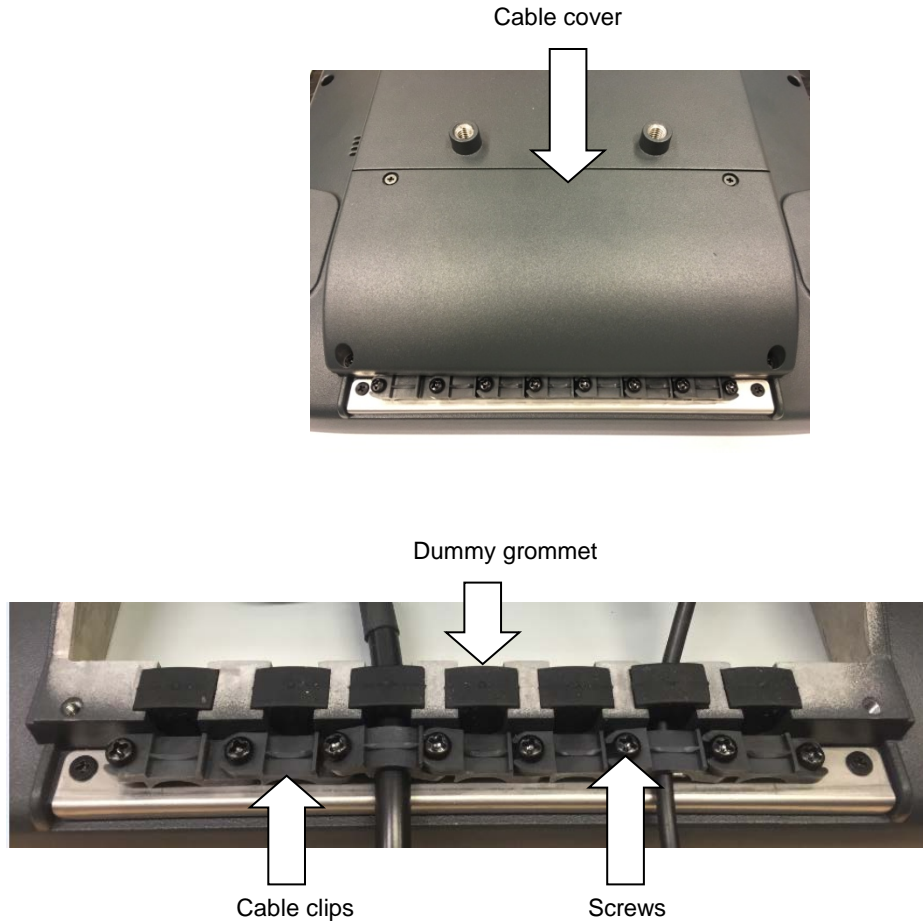

8.3. Inserting the cable grommet in the cable compartment

- ⇒ Select suitable cable grommet which diameter of middle hole can fit the cable's diameter.
- ⇒ There's opening on the cable grommet, please open it and put the cable through it.
- ⇒ Place the cable grommet in the frame of the cable compartment (as pictured).
- ⇒ Press the plugs of the cable grommet into the holes of the frame.
- ⇒ If there's no cable in the compartment, please put **dummy grommet** into it.

Fig. 8.3: Example - 2 cables with cable grommets and 5 dummy grommets inserted

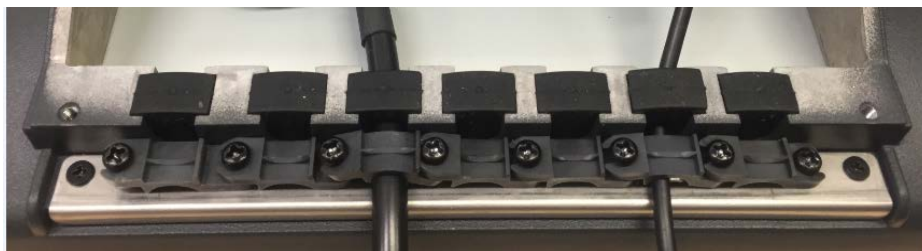

8.4. Power cable, grounding



WARNING

Electrical shock or fire due to incorrect cable routing or insufficient grounding.

- ⇒ Only use original Advantech-DLoG power cables; they meet the specific requirements for low-temperature flexibility, UV resistance, oil resistance, etc.
- ⇒ Make sure that the power supply cables are running without kinks and protected (securely protected against crushing and abrading).
- ⇒ DLT-V6210 may only be connected to a SELV circuit (Safety Extra Low Voltage). The SELV circuit is a secondary circuit that is designed to protect the voltage from exceeding the safe value when operation runs correctly or a single error occurs.
- ⇒ The DC+ connecting cable must be protected by a fuse (30 AT max.).
- ⇒ The ignition connecting cable must be protected by a fuse of the following type: 5x20 mm T 125 mA L / 250 V, for example, a Wickmann 195-125 mA / 250 V.
- ⇒ Observe the correct voltage ranges.
- ⇒ Ensure that power supply cables are fused correctly.
- ⇒ Read the labeling on the cable and connect the power supply cable with the correct polarity.
- ⇒ Cut the power supply cable to the minimum length to ensure the power supply with an appropriate cable installation.
- ⇒ Connect the power supply cable to a suitable supply point.
- ⇒ Ensure that the connecting cable has an adequate cross section and ampacity at the connection point.

NOTICE: Physical damage

Observe the potential ratios.

On DLT-V6210, logic ground and shield ground are firmly connected to each other. Logic ground is the ground (GND) used to supply the internal parts and components such as the display or CPU. All cable shields and the housing are connected to shield ground.

The chassis of some forklifts is on DC+. This means that DLT-V6210 chassis is also on DC+. Short circuits can arise when, for example, the ground potential of a peripheral device is on DC-. This may cause malfunctions or irreparable damage to DLT-V6210.

- ⇒ Always attach the ring tongue of the power supply cable to the provided ground bolt situated on the connector panel.
- ⇒ The other end of the yellow-green power supply cable must be connected to the vehicle chassis.
- ⇒ Connect the power supply cable of DLT-V6210 as directly as possible to the battery.
- ⇒ Don't connect the power supply cable of DLT-V6210 to electromagnetically highly loaded power supply lines (e.g. the engine power supply).
- ⇒ Don't connect the power supply cable of DLT-V6210 to power supply lines which are potentially loaded by other consumers.
- ⇒ Connecting DLT-V6210 to large electrical loads, such as converters for the forklift motor may result in random restarts, malfunctions and/or irreparable damage to the device.
- ⇒ If you want to connect devices fed by other power sources to DLT-V6210 (e.g. printers), be sure to power up the peripheral devices at the same time or after DLT-V6210; otherwise, you may encounter start-up problem, malfunctions or even irreparable damage to the device.

8.4.1. Plugging in and screwing on the power supply cable

Fig. 8.4: The power supply cable secured



- ⇒ Plug the power supply cable into the power supply plug-in location.
- ⇒ Tighten both mounting screws hand-tight.

8.4.2. Securing the ground using ring tongue to the ground bolt

Fig. 8.5: Ring tongue secured to the ground bolt

- ⇒ Secure the ring tongue of the power supply cable to the ground bolt.

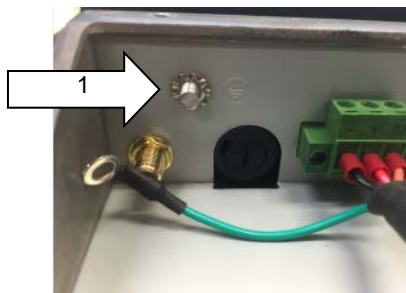

ATTENTION: To make sure the device is grounding correctly, it is important to follow the correct order to put the components on the ground bolt as below (from inside to outside):

1. Place "**toothed washer**" first (internal).
2. Then put the "**Ring Tongue of the power supply cable**" (flat side faces DLT-V6210 connector panel).

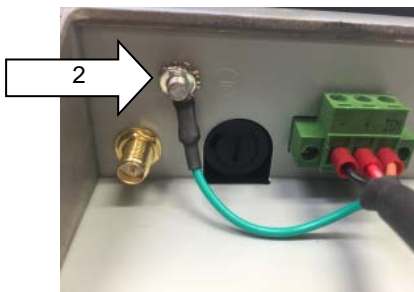

3. Tightening the nut hand-tight.

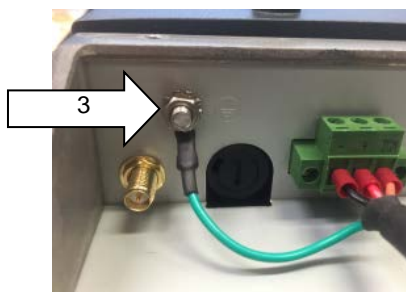

8.4.3. Securing the power supply cable to the strain relief rail

- ⇒ Attach the matching cable grommet to the power supply cable.
NOTICE: Opening of the cable grommet must be slightly smaller than the cable diameter.
- ⇒ Insert the cable grommet including the power supply cable into the cable pass-through
- ⇒ Place one cable clip on the power supply cable.
- ⇒ Secure the cable clip to the strain relief rail using 2 mounting screws (M3x10 screws).
- ⇒ Tighten the mounting screws alternately.
- ⇒ **ATTENTION:** Screw on sufficiently but make sure that the cable is not pinched or damaged.

Fig. 8.6: Cable clip secured to the strain relief rail.

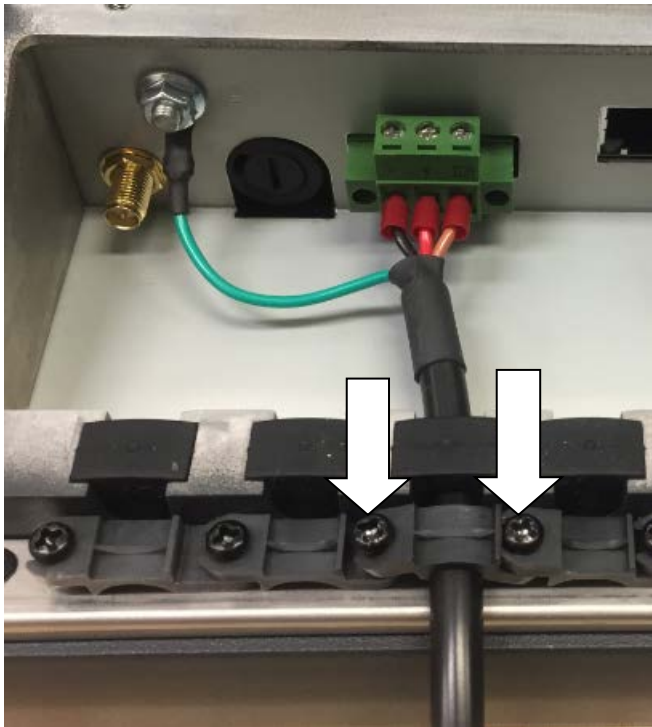

8.5. Connecting the USB, Ethernet and COM cables

NOTICE: Physical damage

Observe the following instructions when connecting/removing external devices to/from DLT-V6210.

- ⇒ Only use accessories that have been tested and approved by Advantech-DLoG for the respective DLT-V6210.
- ⇒ DLT-V6210 may not be connected to the power supply if external devices are being connected/removed (not applicable for USB devices)
- ⇒ Otherwise considerable damage could be caused to both DLT-V6210 and the peripheral devices.
- ⇒ Make sure that peripherals with their own power supply are either switched on at the same time as DLT-V6210 or after the start of DLT-V6210.
- ⇒ Otherwise, you must ensure that the backflow from the external device to DLT-V6210 cannot take place.
- ⇒ Only power up DLT-V6210 when all devices are completely connected and DLT-V6210 is closed correctly (remember the cable cover!). Otherwise, you may damage DLT-V6210.



Please observe the mounting instructions supplied with the optional accessory.

8.5.1. USB cable

- ⇒ Attach the matching cable grommet to the USB cable.
NOTICE: Opening of the cable grommet must be slightly smaller than the cable diameter.
- ⇒ Insert the cable grommet including the USB cable into the cable pass-through
- ⇒ Place one cable clip on the USB cable.
- ⇒ Secure the cable clip to the strain relief rail using 2 mounting screws (M3x10 screws).
- ⇒ Tighten the mounting screws alternately.
- ⇒ **ATTENTION:** Screw on sufficiently but make sure that the cable is not pinched or damaged.

Fig. 8.7: USB cable on the connector panel; secured to the strain relief rail

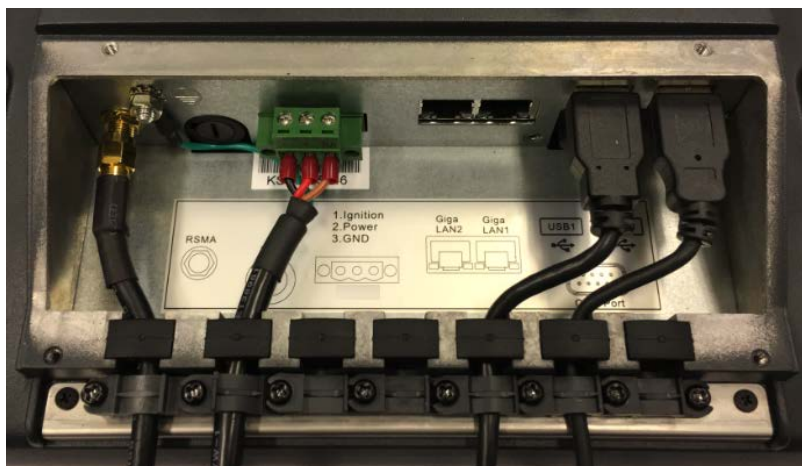

8.5.2. Ethernet cable

- ⇒ Attach the matching cable grommet to the Ethernet cable.
NOTICE: Opening of the cable grommet must be slightly smaller than the cable diameter.
- ⇒ Insert the cable grommet including the Ethernet cable into the cable pass-through
- ⇒ Place one cable clip on the Ethernet cable.
- ⇒ Secure the cable clip to the strain relief rail using 2 mounting screws (M3x10 screws).
- ⇒ Tighten the mounting screws alternately.
- ⇒ **ATTENTION:** Screw on sufficiently but make sure that the cable is not pinched or damaged.

Fig. 8.8: Ethernet cable on the connector panel; secured to the strain relief rail

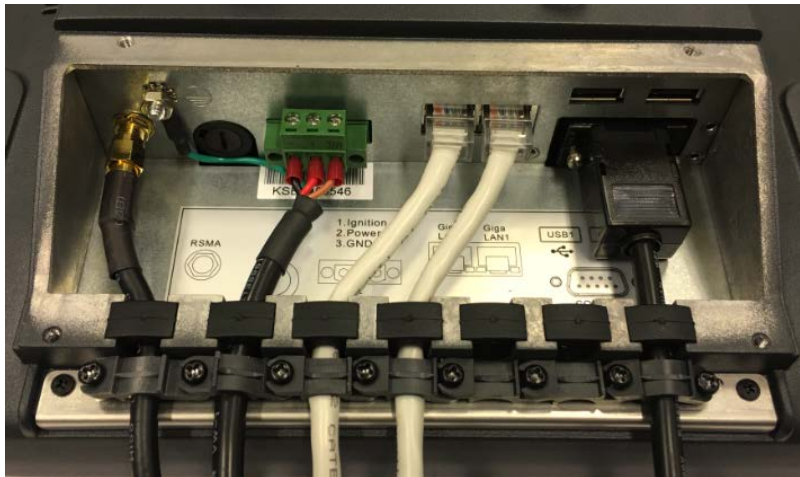

8.5.3. COM cable

- ⇒ Attach the matching cable grommet to the COM cable.
- NOTICE:** Opening of the cable grommet must be slightly smaller than the cable diameter.
- ⇒ Insert the cable grommet including the COM cable into the cable pass-through
- ⇒ Place one cable clip on the COM cable.
- ⇒ Secure the cable clip to the strain relief rail using 2 mounting screws (M3x10 screws).
- ⇒ Tighten the mounting screws alternately.
- ⇒ **ATTENTION:** Screw on sufficiently but make sure that the cable is not pinched or damaged.

Fig. 8.9: COM cable on the connector panel; secured to the strain relief rail

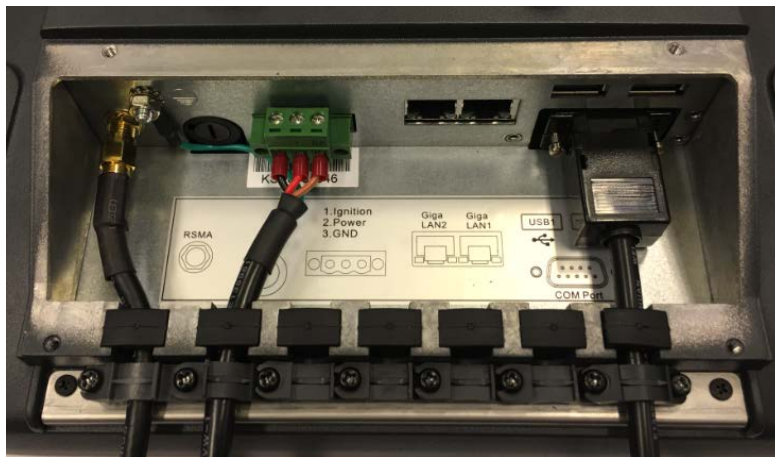

8.6. Closing off unused cable compartment openings

- ⇒ Close off all unused cable compartment openings with the dummy grommet so that they are sealed.

Fig. 8.10: Unused cable outlets sealed off with dummy grommet

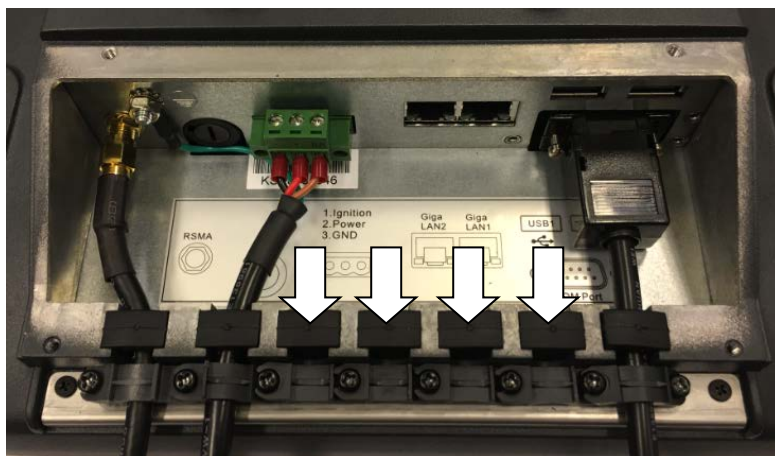

8.7. Attaching the cable cover

NOTICE: Physical damage

The device is not completely sealed due to incorrect attachment of the cables and the cable cover.

The protection class/category of DLT-V6210 is only ensured if the cable cover is properly installed. Improper installation can result in liquid penetrating into DLT-V6210 during operation. This will cause the risk of short-circuiting, corrosion and wear.

- ⇒ Place the cable cover in DLT-V6210 housing slot.
- ⇒ Lock the screws loosely into the holes of the cable cover.
- ⇒ Then fully tighten the screws with 3 Nm torque.

Fig. 8.11: Cable cover closed and screwed together



8.8. Automatic shutdown – functional description

DLT-V6210 is equipped with an automatic shutdown module.

If wired up accordingly, DLT-V6210 conveniently switches off together with the ignition.

As disconnecting the power supply during operation can lead to data loss, the operating system needs to be shut down normally by using the appropriate hardware and software installed on the system when the ignition is switched off.

DLT-V6210 is connected with three supply cables. DC+ and DC- are directly connected to the power supply, the connection is run through fuses.

Please find fuse type details in section *8.4 Power cable, grounding*

The supply voltage is then linked to DLT-V6210's ignition input via a switch, for example, the key switch of the ignition (also with a fuse).

Sequence

When the ignition is turned on or DLT-V6210 <Power> button is pressed (depends on configuration), DLT-V6210 checks its internal temperature and runs a test to confirm that the automatic shutdown function is working.

If the check of the environmental conditions is successful, DLT-V6210 starts the operating system normally.

Once these checks are completed, DLT-V6210 starts the operating system.

The environmental conditions (OTP/UTP/Sensor Faulty) are constantly being checked all the time.

The ignition status is constantly monitored at all times as well.

If DLT-V6210's internal temperature reaches a critical level, shutdown of the operating system will be carried out. The computer will remain switched off until the temperature is once again within the permitted range.

If the ignition input is grounded or isolated during normal operation of DLT-V6210, the device will switch to a delayed shut-off state.

The device will continue to operate normally in this state until the shut-off delay (e.g. 20 minutes) has elapsed.

If the ignition is turned on again during this shut-off delay, DLT-V6210 will revert to a normal operational state.

Once the shut-off delay (after run time) has elapsed, the operating system will shut down and the device will automatically shut down (e.g. after one minute or a signal from the operating system).

Device shut down

If the operating system is shut down, all applications will be notified via the Windows message "WM_QUERYENDSESSION" first.

Every application must then respond within the time set in the registry. If there is no response within the preset time, the application will be hard-terminated.

It may not be possible to close an application automatically if it has unsaved data. For example, the WORDPAD.EXE program (included in Windows) cannot be closed automatically if there are unsaved changes. In such a situation, WORDPAD.EXE will acknowledge the "WM_QUERYENDSESSION" Windows message by prompting the user to choose whether to save it or not.

All applications that can be terminated without user confirmation using the keyboard shortcut <ALT> + <F4>, which will normally also respond correctly to the "WM_QUERYENDSESSION" message and therefore do not need to be hard-terminated.

To ensure that the important data is saved correctly, the application must respond appropriately to "WM_QUERYENDSESSION", i.e. the backup data must be saved without user confirmation and within the preset time.

Configuration

„MDevice program" is used to configure the automatic shutdown function.



The „MDevice manual" can be found online in the download center at www.advantech-dlog.com.

9. Operation

9.1. Switching DLT-V6210 on/off

Switch on

Switch DLT-V6210 on as follows, depending on the configuration:

- ⇒ Press the <Power> button.
- ⇒ Or: Through the ignition signal of the vehicle (depends on the vehicle management / automatic shutdown settings).

Fig. 9.1: <Power> button



Switch off

Switch DLT-V6210 off as follows, depending on the configuration:

- ⇒ Press the <Power> button of the activated DLT-V6210.
- ⇒ Or: Disconnect the supply voltage.
NOTICE: Devices will be hard-terminated (data loss possible).
- ⇒ Or: Deactivate the ignition of the connected vehicle (depends on the vehicle management / automatic shutdown settings).

Time between switching off and on: 10 seconds

After DLT-V6210 is shut down and switched off, it needs to wait at least 10 seconds until the device can react to a switch-on signal (<Power> button / ignition).

9.2. Operating the touchscreen (PCT)

NOTICE: Physical damage

Prevent damage to the touchscreen

- ⇒ Keep the touchscreen clean.
- ⇒ Do not touch the touchscreen with pointed, sharp, rough or hard objects, e.g. ball point pens, writing implements, tools of any kind (e.g. screwdrivers).
- ⇒ Make sure that no adhesives get on the surface of the touchscreen.
- ⇒ Ensure that the touchscreen surface is not influenced by high voltages or static electricity.
- ⇒ Do not use excessive force when touching the touchscreens, and do not hit or press hard.
- ⇒ If the device with the touchscreen is placed down: Place a clean, soft cloth underneath.

- ⇒ Salty water on the PCT touchscreen can be interpreted as a "touch" and lead to malfunction

Operating the touchscreen with

- Clean, dry fingers
- Clean, dry, soft gloves
- Suitable touch stylus

Multi-touch capability

Depending on the installed operating system type, the PCT touchscreen of DLT-V6210 is multi-touch capable. This means it can detect two touch points simultaneously.

9.3. Front keys and LEDs

9.3.1. Overview

Fig. 9.2: Operating elements: Front keys and LED

Keys:

- Power on/off
- Display brightness up
- Display brightness down



9.4. Operating states

Status of LEDs	DLT-V6210 status
Supply voltage (green) 	
OFF	Waiting for a new ignition signal or activation of the <Power> key after switch-off; no voltage supply
STATIC ON	Computer start-up/normal operational state/shutdown delay time
Blinking : 0.2 sec. on / 0.8 sec. off	Temperature sensor faulty
Blinking : 0.5 sec. on / 0.5 sec. off	Ambient temperature lies beyond the permitted range

10. External connectors

10.1. Connectors under the cable cover

Fig. 10.1: Connectors under the cable cover

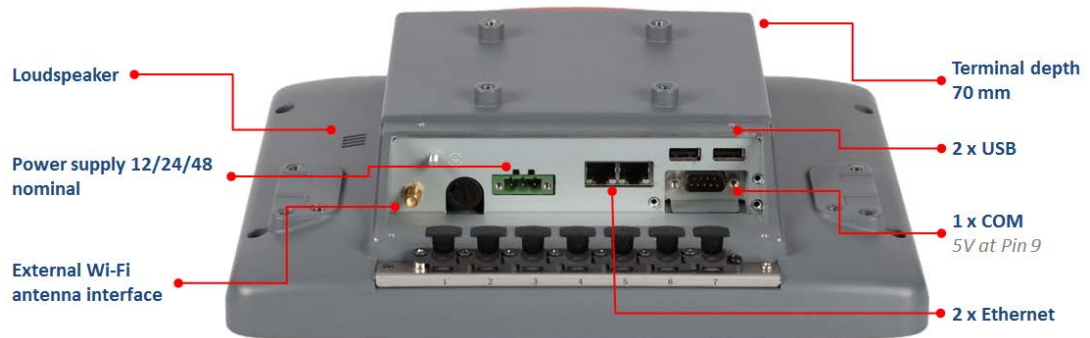
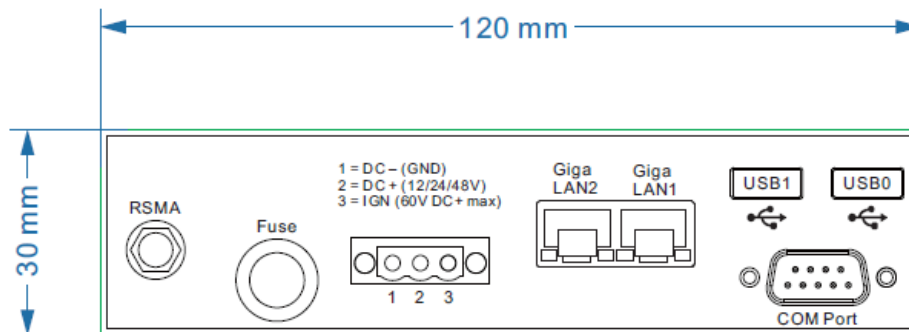

Fig. 10.2: Graphical detail view connectors under the cable cover



10.1.1. Serial COM interface

- Max. 115,200 Baud (16550A compatible, 16 byte FIFO)
- Supports EIA-232-E on external 9-pin D-Sub connection
- ESD Level 4 protected (according to EN 61000-4-2)

COM interface as a voltage source

The COM interface can supply to externally connected equipment with +5 VDC.

The voltage is protected by an internal fuse and may not exceed a continuous consumed current of 1 A at 5 V. Depending on the connected device, the maximum current consumption may be significantly lower.

10.1.2. USB

- 2 x USB 2.0 Hi-Speed HOST A typ, 5 VDC 500 mA
- Fused at 0.5 A per channel
- ESD Level 4 protected (according to EN 61000-4-2)

10.1.3. Network adapter (10/100/1000)

- 2 x network adapter (RJ45 connection jack) with 10/100/1000 Mbit per second

The RJ45 connection ports have two integrated status LEDs and are assigned as follows:

Fig. 10.3: RJ45 network port

Left LED (Green):

LED off: no connection
 LED on: connection (link)
 LED flashing: activity

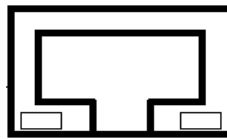

Right LED (Green + Orange):

LED off: no connection/10 Mbps
 LED green: 100 Mbps
 LED orange: 1000 Mbps

Problems with data transmission via LAN/Ethernet

If problems occur during data transmission over LAN/Ethernet (e.g. data is lost or not detected), the cause of these problems may be the cable is too long.

Depending on the cable layout and interference from the environment, it may be impossible to use the cable length of 100 m given in the specification (IEEE 802.3 standard).

The recommendation in this context is to use a shorter cable.

10.2. CFast slot under the antenna cap

There is a CFast slot under the antenna cap.

- ⇒ Exercise special care when removing and re-inserting CFast card.
- ⇒ Only use CFast cards that have been approved by Advantech-DLoG.

NOTICE: Physical damage

Improper opening of the antenna cap can impair the function of entire DLT-V6210 system and in particular the Wi-Fi functionality.

- The antenna cap may only remain open during the service work.
- No objects or liquids may enter the opened DLT-V6210 during this.
- Only when the antenna cap is properly closed again may operation be resumed; the protection class/category is only ensured again after doing so.

10.3. Opening/closing the antenna cap

Opening

- ⇒ Loosen the two screws of the antenna cap using Torx screwdriver.
- ⇒ Carefully lift up the antenna cap.

Fig. 10.4: Antenna cap opened

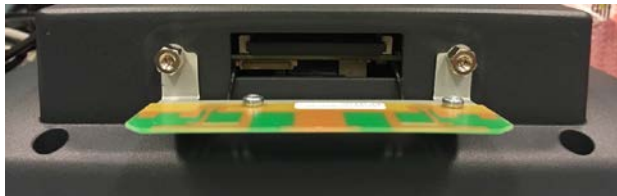

Closing

- ⇒ Place the antenna cap back onto DLT-V6210.
- ⇒ The antenna cap seal must not be damaged; it must be seated correctly in the groove.
- ⇒ Tighten the two screws of the antenna cap again (1 Nm torque).

11. Integrated power supply unit

DLT-V6210 is equipped with a galvanically separated, integrated DC power supply unit. Power is connected to the back of the unit using a Phoenix Contact plug. There is no power switch.

Power supply	
DC power supply unit 12/24/48 VDC (wide-range power supply unit)	12/24/48 VDC nominal Galvanically isolated Withstands bursts up to 2 kV
Voltage range	9 to 60 VDC
Maximum output power	Vin < 36 V => 42 W Vin > 36 V => 50.4 W
Nominal current	12 V: 3.5 A 24 V: 1.75 A 48 V: 0.875 A
Connection to SELV circuit only	The SELV circuit is a secondary circuit that is designed to protect from the voltage exceeding the safe value when operation runs correctly or if a single error occurs.
Power consumption	Typically 34 W

Power supply unit fuses		
<i>Power supply unit</i>	<i>Fuse type</i>	<i>Example</i>
ADLoG owned-design power supply unit	5 x 20 mm, 8 A, 250 V	LittleFuse 0477008.MXP or similar product produced by other manufacturers

The symbol of the fuse is **FA**. You will find the exact position on the sticker located on the connection plate of DLT-V6210.

11.1. DC voltage supply connection

Version: Phoenix Combicon, 3-pin.

External view:

Fig. 11.1: DC power supply connector with power cable connector detail view

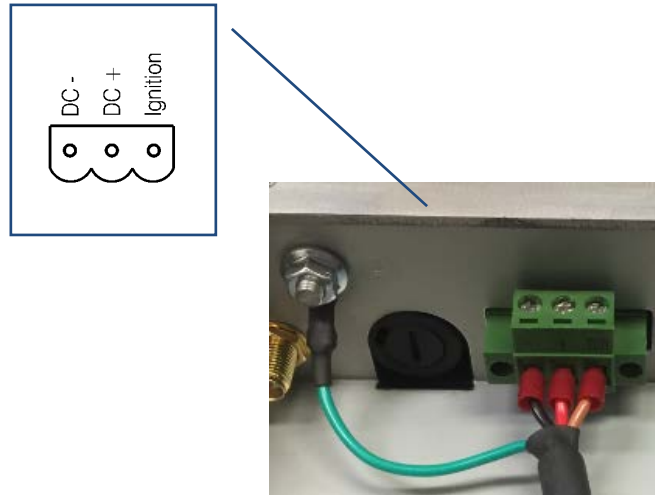

Explanation:

“Ignition on” means that a control signal can be routed to this connection that matches the supply voltage level. The signal reference is DC-.

11.2. DC Power supply cable

Fig. 11.2: DC Power supply cable with Phoenix Combicon, 3-pin



WARNING

Electrical shock or fire due to incorrect power supply cable.

- ⇒ Only use original Advantech-DLoG power supply cables; these meet the specific requirements for low-temperature flexibility, UV resistance, oil resistance, etc.

Fig. 11.3: DC connection cable pin assignment

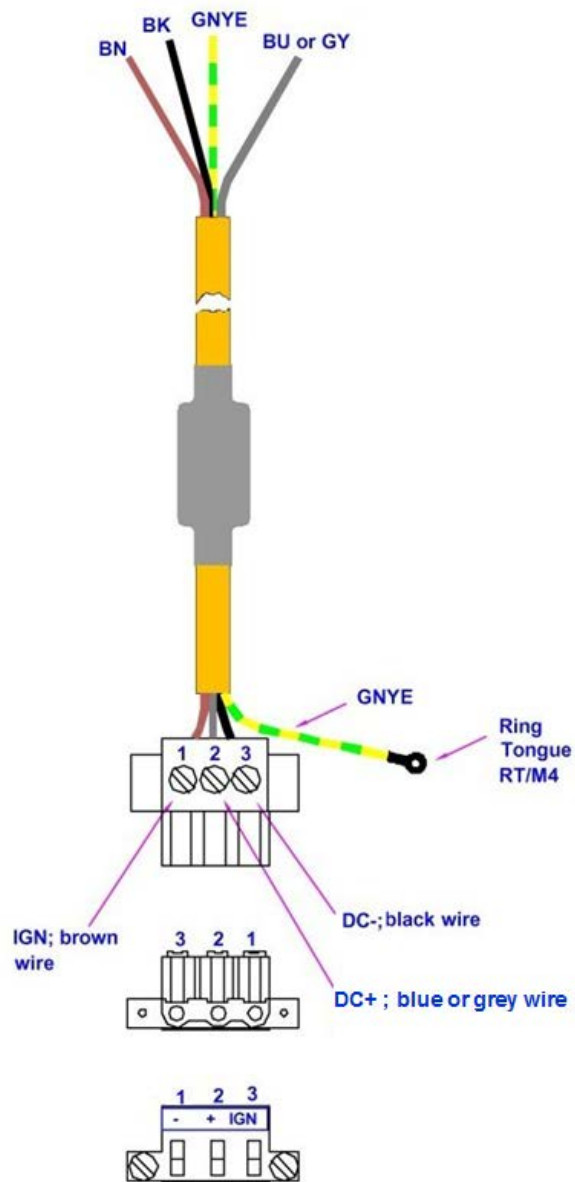

12. Optional equipment

NOTICE: Physical damage

Please only use accessories that have been tested and approved by Advantech-DLoG for the respective DLT-V6210.

12.1. Integrated low profile Wi-Fi antenna (optional)

Fig. 12.1: Integrated low profile Wi-Fi antenna (optional)



Technical data	
Application	Wi-Fi IEEE 802.11 a/b/g/n Dual Band Diversity
Number of antennas	2
Type	Omnidirectional antenna
Directionality	Optimized for the DLT-V6210 housing
Frequency range	Band 1: 2400 to 2485 MHz Band 2: 5150 to 5875 MHz
Antenna gain	Max. 5 dBi (without loss through the cable)
Impedance	50 Ω
Polarization	Vertical/Horizontal
Maximum transmitting power	100 mW / 20 dBm

12.2. External Wi-Fi antenna, remote (optional)

Fig. 12.2: Remote Wi-Fi antenna (optional)



Technical data	
Application	Wi-Fi IEEE 802.11 a/b/g/n dual-band
Mounting location	For detached (remote) installation, e.g. on the roof of the forklift
Number of antennas	1
Type	Omnidirectional antenna
Frequency range	Band 1: 2400 to 4900 MHz Band 2: 4900 to 6000 MHz
Antenna gain	Band 1: Max. 4 dBi (without loss through the cable) Band 2: Max. 6.5 dBi (without loss through the cable)
Impedance	50 Ω
Polarization	Vertical/Horizontal
Dimensions	\varnothing 86 x 43 mm (\varnothing 3.39" x 1.69")
Weight	0.3 kg (0.66 lbs)
Connector labeling	N type or TNC N, jack, female, bottom RSMA plug for RSMA socket on the terminal
Scope of delivery	3 m antenna cable
Maximum transmitting power	100 mW / 20 dBm

12.3. Wi-Fi card (optional)

Technical data	
Wi-Fi PCIe MiniCard	Integrated in the device at the factory by Advantech-DLoG (internal PCIe MiniCard slot).
Driver	Generally, only drivers for Wi-Fi cards approved by Advantech-DLoG can be integrated into operating system images.
Maximum radiated power	100 mW EIRP

12.4. Keyboards and keyboard mounts (optional)

A USB keyboard can be connected to DLT-V6210.

Advantech-DLoG offers the following keyboards and mountings:

Fig. 12.3: SMALL keyboard



- SMALL keyboard
- Mountable
- Protection class IP65
- Keyboard layouts: German, English, French

Fig. 12.4: 24-key keypad



- 24-key keypad
- Mountable
- Protection class IP65

Fig. 12.5: Keyboard mounting examples

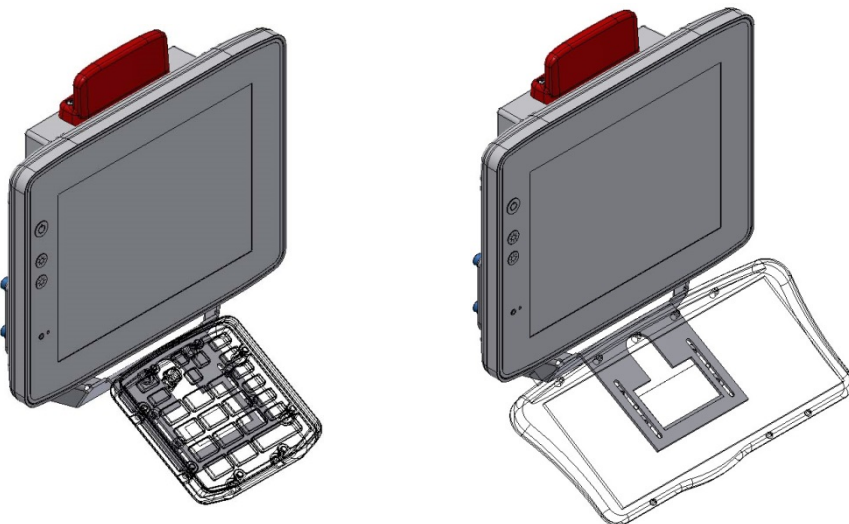

12.5. Scanner and scanner bracket (optional)

You can connect scanners to either the USB interface or the serial interface. Optional scanner brackets are available for DLT-V6210.

Please contact your Advantech-DLoG sales representative if needed.

If connected to COM, the scanner can be powered through the interface with a voltage of 5 V.

Fig. 12.6: Example scanner bracket

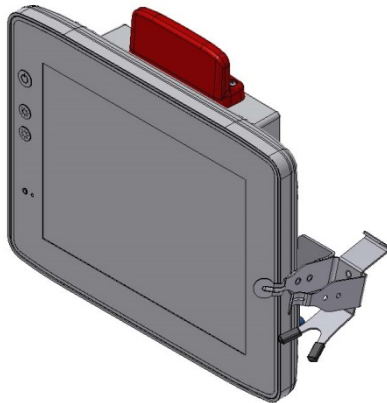

12.6. Touch stylus (optional)

Advantech-DLoG offers a touch stylus pen with associated mounting for the DLT-V6210.

Please contact your Advantech-DLoG sales representative if needed.

Fig. 12.7: Touch stylus example

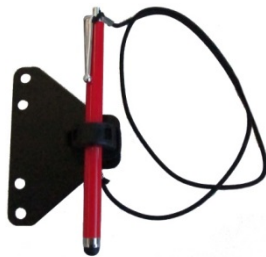

12.7. USB recovery stick (optional)

The optional Advantech-DLoG recovery stick allows images to be backed up and restored onto DLT-V6210 when necessary (backup & recovery). Please contact your Advantech-DLoG sales representative if needed.

13. Maintenance

Only the manufacturer and its authorized service centers may perform repairs and modifications, replace modules and open the device.

The legal warranty shall apply. It expires if the customer performs measures on the device that are only permitted to be performed by the manufacturer and its authorized Service Centers.

13.1. Regular checks and maintenance of the complete system

To ensure the stability and security of DLT-V6210 system at the respective application site:

- ⇒ Regularly check whether DLT-V6210 is firmly seated in the associated holder (RAM mount, mounting bracket) and the mounting screws are not loose.
- ⇒ Also check whether the bracket is secured stably to the respective deployment location. This is particularly important if DLT-V6210 is installed on any vehicle.
- ⇒ Check whether all connected cables are secured and the cable cover shuts tightly.



WARNING

Risk of accident due to unstable attachment of DLT-V6210.

If the attachment of DLT-V6210 becomes loose and breaks during moving, this can lead to severe accidents.

- ⇒ Perform checks for the attachment as described above at regular intervals.

13.2. Cleaning the DLT-V6210



WARNING

Hazardous voltage, electrical shock from contact with live parts when cleaning the device.

To prevent an electrical shock while cleaning the device:

- ⇒ Switch off DLT-V6210 before cleaning.
- ⇒ Disconnect from the power supply.
- ⇒ Disconnect all connected accessories.

NOTICE: Physical damage

Cleaning the touchscreen and housing:

- ⇒ Never use chemical solvents to clean the touchscreen.
- ⇒ Do not use acidic or alkaline solutions.
- ⇒ Do not use cleaning agents that contain ammonia or sulfur (tile cleaners, for example, contain ammonia).
- ⇒ Do not use any abrasive glass cleaner or cloths that could scratch the touchscreen.

Cleaning the housing

- ⇒ Ensure that DLT-V6210 is switched off and currentless.
- ⇒ Clean the housing with a slightly dampened cloth.
- ⇒ Do not use compressed air, a high-pressure cleaner or vacuum cleaner, as this can damage the surface. Using a high-pressure cleaner poses the additional risk of water entering the device and damaging the electronics or display.

Cleaning the touchscreen

- ⇒ Ensure that DLT-V6210 is switched off and currentless.
- ⇒ Use a neutral glass cleaner without ammonia or isopropyl alcohol applied to a lint-free cloth.
ATTENTION: Do not apply cleaning agent to the touchscreen; apply it to the cleaning cloth.
- ⇒ Use only solvents-free detergents.
- ⇒ Then wipe off the touchscreen with it.

14. Malfunctions

Problem	Cause / remedy
Imprecise reaction of touchscreen	<p>The touchscreen of DLT-V6210 is already calibrated at the factory and therefore does not need to be recalibrated.</p> <p>However, some operating systems do permit recalibration of the touchscreen via software (Menu Control Panel -> Tablet PC Settings).</p> <p>This resets the sensitivity of the touchscreen to an operating system default setting, which can result in poorer detection of taps on the screen.</p> <p>You can use Reset to reset the software recalibration.</p>

Please contact DLoG GmbH if DLT-V6210 malfunctions. You can find the contact address in section *Technical customer support*.

15. Reasonably foreseeable misuse

Observe the intended use

The DLT-V6210 industrial PCs are data communication terminals for use in commercial environments (e.g. logistics, warehousing, manufacturing).

The DLT-V6210 industrial PCs:



- are not approved for use in EX zones (potential explosion hazard).
- are not approved for use on ships.
- are not approved for use in life-support systems or critical safety systems where system malfunction can lead to the direct or indirect endangerment of human life.

⇒ Observe the permissible environmental conditions.

⇒ Observe correct voltage ranges.

16. Guidelines and certificates

16.1. Overview

▪ Europe: CE	
▪ Northern America: FCC	
▪ China market: CCC	
▪ Japan: TELEC	
▪ Taiwan: BSMI and NCC	

16.1. EMC guideline

16.1.1. Shielded components

All components connected to the DLT-V6210, as well as cable connections must meet the legal EMC requirements for compliance with the EMC legislation.

Screened bus, LAN cables and connectors must be used.

16.1.2. EMC EU

DLT-V6210 devices fulfill the requirements of the EU Directive "2014/30/EU Elektromagnetische Verträglichkeit" (Electromagnetic Compatibility).

16.2. FCC USA/CAN

This equipment has been tested and found to comply with the limits for a Class B digital device, pursuant to Part 15 of the FCC Rules.

These limits are designed to provide reasonable protection against harmful interference in a residential installation. This equipment generates, uses and can radiate radio frequency energy and, if not installed and used in accordance with the instructions, may cause harmful interference to radio communications. However, there is no guarantee that interference will not occur in a particular installation. If this equipment does cause harmful interference to radio or television reception, which can be determined by turning the equipment off and on, the user is encouraged to try to correct the interference by one of the following measures:

- ⇒ Reorient or relocate the receiving antenna.
- ⇒ Increase the separation between the equipment and receiver.
- ⇒ Connect the equipment into an outlet on a circuit different from that to which the receiver is connected.
- ⇒ Consult the dealer or an experienced radio/TV technician for help.

FCC Caution: Any changes or modifications not expressly approved by the party responsible for compliance could void the user's authority to operate this equipment.

FCC RF Radiation Exposure Statement:

1. This Transmitter must not be co-located or operating in conjunction with any other antenna or transmitter.
2. This equipment complies with FCC RF radiation exposure limits set forth for an uncontrolled environment.

This equipment should be installed and operated with a minimum distance of 20 centimeters between the radiator and your body.

This device complies with FCC radiation exposure limits set forth for an uncontrolled environment and it also complies with Part 15 of the FCC RF Rules.

This equipment must be installed and operated in accordance with provided instructions and the antenna(s) used for this transmitter must be installed to provide a separation distance of at least 20 cm from all persons and must not be co-located or operating in conjunction with any other antenna or transmitter. End-users and installers must be provided with antenna installation instructions and consider removing the no-collocation

Statement.

This device complies with Part 15 of the FCC Rules. Operation is subject to the following two conditions:
 (1) this device may not cause harmful interference, and
 (2) this device must accept any interference received, including interference that may cause undesired operation.



CAUTION

Any changes or modifications not expressly approved by the party responsible for compliance could void the user's authority to operate the equipment.

Canada

This device complies with Industry Canada licence-exempt RSS standard(s). Operation is subject to the following two conditions: (1) this device may not cause interference, and (2) this device must accept any interference, including interference that may cause undesired operation of the device.

Le présent appareil est conforme aux CNR d'Industrie Canada applicables aux appareils radio exempts de licence. L'exploitation est autorisée aux deux conditions suivantes : (1) l'appareil ne doit pas produire de brouillage, et (2) l'utilisateur de l'appareil doit accepter tout brouillage radioélectrique subi, même si le brouillage est susceptible d'en compromettre le fonctionnement.

Industry Canada - Class B This digital apparatus does not exceed the Class B limits for radio noise emissions from digital apparatus as set out in the interference-causing equipment standard entitled "Digital Apparatus," ICES-003 of Industry Canada.

Cet appareil numérique respecte les limites de bruits radioélectriques applicables aux appareils numériques de Classe B prescrites dans la norme sur le matériel brouilleur: "Appareils Numériques," NMB-003 édictée par l'Industrie.

FCC ID: M82-DLV6210

IC: 9404A-DLV6210

SW: V1.0

HW: V1.0

16.3. RED (Radio Equipment Directive) 2014/53/EU

With regard to the RED (Radio Equipment Directive) 2014/53/EU the statements as below in the declaration of conformity for DLT-V6210 industrial PC to apply.

Česky [Czech]:	Toto zařízení je v souladu se základními požadavky a ostatními odpovídajícími ustanoveními Směrnice 2014/53/EU.
Dansk [Danish]:	Dette udstyr er i overensstemmelse med de væsentlige krav og andre relevante bestemmelser i Direktiv 2014/53/EU.
Deutsch [German]:	Dieses Gerät entspricht den grundlegenden Anforderungen und den weiteren entsprechenden Vorgaben der Richtlinie 2014/53/EU.
Eesti [Estonian]:	See seade vastab direktiivi 2014/53/EU (EÜ) olulistele nõuetele ja teistele asjakohastele sätetele.
English:	This equipment is in compliance with the essential requirements and other relevant provisions of Directive 2014/53/EU.
Español [Spanish]:	Este equipo cumple con los requisitos esenciales así como con otras disposiciones de la Directiva 2014/53/EU (CE).
Ελληνική [Greek]:	Αυτός ο εξοπλισμός είναι σε συμμόρφωση με τις ουσιαστικές απαιτήσεις και άλλες σχετικές διατάξεις της Οδηγίας 2014/53/EU.
Français [French]:	Cet appareil est conforme aux exigences essentielles et aux autres dispositions pertinentes de la Directive 2014/53/EU.
Íslenska [Icelandic]:	Þetta tæki er samkvæmt grunnkröfum og öðrum viðeigandi ákvæðum Tilskipunar 2014/53/EU.
Italiano [Italian]:	Questo apparato é conforme ai requisiti essenziali ed agli altri principi sanciti dalla Direttiva 2014/53/EU (CE).
Latviski [Latvian]:	Šī iekārta atbilst Direktīvas 2014/53/EU (EK) būtiskajām prasībām un citiem ar to saistītajiem noteikumiem.
Lietuvių [Lithuanian]:	Šis įrenginys tenkina 2014/53/EU (EB) Direktyvos esminius reikalavimus ir kitas šios direktyvos nuostatas.
Nederlands [Dutch]:	Dit apparaat voldoet aan de essentiële eisen en andere van toepassing zijnde bepalingen van de Richtlijn 2014/53/EU.
Malti [Maltese]:	Dan l-apparat huwa konformi mal-ħtiġiet essenzjali u l-provedimenti l-oħra rilevanti tad-Direttiva 2014/53/EU.
Magyar [Hungarian]:	Ez a készülék teljesíti az alapvető követelményeket és más 2014/53/EU (EK) irányelvben meghatározott vonatkozó rendelkezéseket.
Norsk Norwegian]:	Dette utstyret er i samsvar med de grunnleggende krav og andre relevante bestemmelser i EU-direktiv 2014/53/EU (EF).
Polski [Polish]:	Urządzenie jest zgodne z ogólnymi wymaganiami oraz szczególnymi warunkami określonymi Dyrektywą UE: 2014/53/EU.
Português [Portuguese]:	Este equipamento está em conformidade com os requisitos essenciais e outras provisões relevantes da Directiva 2014/53/EU.
Slovensko [Slovenian]:	Ta naprava je skladna z bistvenimi zahtevami in ostalimi relevantnimi pogoji Direktive 2014/53/EU.
Slovensky [Slovak]:	Toto zariadenie je v zhode so základnými požiadavkami a inými príslušnými nariadeniami direktív: 2014/53/EU.
Suomi [Finnish]:	Tämä laite täyttää direktiivin 2014/53/EU (EY) olennaiset vaatimukset ja on siinä asetettujen muiden laitetta koskevien määräysten mukainen.
Svenska [Swedish]:	Denna utrustning är i överensstämmelse med de väsentliga kraven och andra relevanta bestämmelser i Direktiv 2014/53/EU.

Wi-Fi special regulations for Germany and France

For DLT-V6210 with Wi-Fi 802.11a/b/g/n, the following restrictions to be applied:

- In Germany, Wi-Fi 5 GHz band: 5.15 GHz – 5.35 GHz may only be used indoors.
- In France, Wi-Fi operation outdoors is only permitted in the 2454 – 2483.5 MHz range at max. 10 mW EIRP.

16.4. CE marking

The devices of DLT-V6210 series were tested and fulfill the CE conformity requirements and carry the CE mark on the rear side of the device.

16.5. Taiwan BSMI screen warning



WARNING

使用過度恐傷害視力。

ATTENTION / NOTICE

使用 30 分鐘請休息 10 分鐘。

未滿 2 歲幼兒不看螢幕，2 歲以上每天看螢幕不要超過 1 小時。

17. End-of-life device disposal



DLT-V6210 devices which are defective or ready for disposal which should be considered as special waste and can be recycled. They must not be disposed as general/domestic waste.



Proper disposal in accordance with local regulations is required.



Please contact the responsible authorities in your country/region to find out about the applicable regulations, if necessary.

18. Technical customer support

Please contact your distributor, sales representative or Advantech-DLoG's customer service center for technical support if you need additional assistance.

Please have the following information ready before you call:

- Product name
- Serial number
- Description of your peripheral attachments
- Description of your software (operating system, version, application software, etc.)
- A complete description of the problem
- The exact wording of any error messages

Contact

Phone: (+49) 89 / 41 11 91 999

Fax (+49) 89 / 41 11 91 - 900

email: helpdesk@advantech-dlog.com

Manufacturer address

DLoG GmbH

Industriestraße 15

D-82110 Germering

Internet: www.advantech-dlog.com

email: info@advantech-dlog.com

19. Return shipment form

Return shipment form (please fill in once per return shipment):

Company	
Street	
Zip code, town	
Contact	
Phone number /E-Mail	

Type(s) of unit(s) returned:

Serial number(s) of the unit(s) returned:

- The units have not been returned, as they are currently being used. However, the following parts are missing:
- Unit was already damaged on delivery (please enclose a copy of the delivery note)
- Delivery was incomplete

Missing parts:

--

- The following error occurs when operating the unit:

--

- Separate error report is enclosed

20. List of figures

Fig. 3.1: Dimensions of DLT-V6210	12
Fig. 7.1: Position VESA drill holes of DLT-V6210.....	21
Fig. 8.1: Cable compartment.....	25
Fig. 8.2: Cable sealing set.....	25
Fig. 8.3: Example - 2 cables with cable grommets and 5 dummy grommets inserted.....	26
Fig. 8.4: The power supply cable secured.....	29
Fig. 8.5: Ring tongue secured to the ground bolt	29
Fig. 8.6: Cable clip secured to the strain relief rail.....	30
Fig. 8.7: USB cable on the connector panel; secured to the strain relief rail	31
Fig. 8.8: Ethernet cable on the connector panel; secured to the strain relief rail.....	32
Fig. 8.9: COM cable on the connector panel; secured to the strain relief rail	33
Fig. 8.10: Unused cable outlets sealed off with dummy grommet	33
Fig. 8.11: Cable cover closed and screwed together	34
Fig. 9.1: <Power> button	37
Fig. 9.2: Operating elements: Front keys and LED	39
Fig. 10.1: Connectors under the cable cover.....	40
Fig. 10.2: Graphical detail view connectors under the cable cover	40
Fig. 10.3: RJ45 network port	41
Fig. 10.4: Antenna cap opened	42
Fig. 11.1: DC power supply connector with power cable connector detail view	44
Fig. 11.2: DC Power supply cable with Phoenix Combicon, 3-pin.....	44
Fig. 11.3: DC connection cable pin assignment	45
Fig. 12.1: Integrated low profile Wi-Fi antenna (optional).....	46
Fig. 12.2: Remote Wi-Fi antenna (optional).....	47
Fig. 12.3: SMALL keyboard.....	48
Fig. 12.4: 24-key keypad.....	48
Fig. 12.5: Keyboard mounting examples.....	48
Fig. 12.6: Example scanner bracket.....	49
Fig. 12.7: Touch stylus example.....	49