



NetVanta 3148/4148 Series Fixed Port Secure Access Routers Hardware Installation Guide

17003148F1	NetVanta 3148 Chassis
17003148F11	NetVanta 3148 PoE Chassis
17004148F1	NetVanta 4148 Chassis
17004148F11	NetVanta 4148 PoE Chassis

Trademarks

Any brand names and product names included in this manual are trademarks, registered trademarks, or trade names of their respective holders.

To the Holder of the Manual

The contents of this manual are current as of the date of publication. ADTRAN reserves the right to change the contents without prior notice.

In no event will ADTRAN be liable for any special, incidental, or consequential damages or for commercial losses even if ADTRAN has been advised thereof as a result of issue of this publication.

Software Licensing Agreement

Each ADTRAN product contains a single license for ADTRAN-supplied software. Pursuant to the Licensing Agreement, you may: (a) use the software on the purchased ADTRAN device only and (b) keep a copy of the software for backup purposes. This Agreement covers all software installed on the system, as well as any software available on the ADTRAN website. In addition, certain ADTRAN systems may contain additional conditions for obtaining software upgrades.



Changes or modifications to this unit not expressly approved by the party responsible for compliance could void the user's authority to operate the equipment.



901 Explorer Boulevard
P.O. Box 140000
Huntsville, AL 35814-4000
Phone: (256) 963-8000

Copyright © 2020 ADTRAN, Inc.
All Rights Reserved.
Printed in U.S.A.

Conventions

**NOTE**

Notes provide additional useful information.

**CAUTION**

Cautions signify information that could prevent service interruption or damage to the equipment.

WARNING

Warnings provide information that could prevent injury or endangerment to human life.

Safety Instructions

If any of the following conditions occur, unplug the product from the electrical outlet and replace the part or contact your qualified service personnel:

1. The power cable, extension cable, or plug is damaged.
2. An object has fallen into the product.
3. The product has been exposed to water.
4. The product has been dropped or damaged.
5. The product does not operate correctly when you follow the operating instructions.



- *These units contain no user-serviceable parts.*
- *Il n'existe aucune pièce pouvant être réparée par l'utilisateur à l'intérieur de cet équipement*



This product meets EU RoHS Directive. Refer to www.adtran.com for further information on RoHS and Waste Electrical and Electronic Equipment (WEEE) safety guidelines.

Save These Important Safety Instructions

FCC and Canadian Radio Frequency Interference Statement

This device complies with Part 15 of the FCC rules. Operation is subject to the following two conditions:

1. This device may not cause harmful interference.
2. This device must accept any interference received, including interference that may cause undesired operation.

Changes or modifications not expressly approved by ADTRAN could void the user's authority to operate this equipment.



- *This equipment has been tested and found to comply with the limits for a Class A digital device, pursuant to part 15 of the FCC Rules. These limits are designed to provide reasonable protection against harmful interference when the equipment is operated in a commercial environment. This equipment generates, uses, and can radiate radio frequency energy and, if not installed and used in accordance with the instruction manual, may cause harmful interference to radio communications. Operation of this equipment in a residential area is likely to cause harmful interference in which case the user will be required to correct the interference at his own expense.*
- *CAN ICES-3(A)/NMB-3(A)*

Service and Warranty

For information on the service and warranty of ADTRAN products, visit the [Support](#) section of the ADTRAN website at <http://www.adtran.com>.



Changes or modifications not expressly approved by ADTRAN will void the warranty.

Table Of Contents

Introduction	9
Physical Description	9
Shipping Contents	10
NetVanta 3148/4148 Series Front Panel Design	10
NetVanta 3148/4148 Series Rear Panel Design	12
NetVanta 3148/4148 Series Front Panel LEDs	12
Features and Specifications	13
Physical Interfaces	13
Processor and Memory	13
Protocols	13
Security	14
Ethernet Features	15
Environment	15
Physical and Input Power	15
Agency Approvals	15
Unit Installation	16
Equipment Required	17
Mounting Options	17
Supplying Power to the Unit	20
Installing SFP Modules in the Unit	21

List of Figures

Figure 1.	NetVanta 3148/4148 Front Panel Layout (non-PoE)	10
Figure 2.	NetVanta 3148/4148 Front Panel Layout (PoE)	11
Figure 3.	NetVanta 3148/4148 Series Rear Panel Layout	12
Figure 4.	Wallmount Installation	20

List of Tables

Table 1.	NetVanta 3148/4148 Series Front Panel LEDs	12
Table A-1.	Copper Gigabit Ethernet Port Pinouts	22
Table A-2.	Switch Port Pinouts	22
Table A-3.	Console Port Pinouts	23
Table A-4.	USB Port Pinouts	23

1. INTRODUCTION

This hardware installation guide describes the NetVanta 3148, NetVanta 3148 Power over Ethernet (PoE), NetVanta 4148, and NetVanta 4148 PoE Series units' physical characteristics, lists their features and specifications, introduces basic functionality, and provides installation instructions in the following sections:

- [Physical Description on page 9](#)
- [Features and Specifications on page 13](#)
- [Unit Installation on page 16](#)



In this document, the term NetVanta 3148/4148 Series means all of the units collectively. If a statement only applies to one particular, switch, the text refers to that switch individually.

For additional information on shipping contents, mounting options, SFP module installation, and supplying power to the unit, refer to the following sections:

- [Shipping Contents on page 10](#)
- [Mounting Options on page 17](#)
- [Supplying Power to the Unit on page 20](#)
- [Installing SFP Modules in the Unit on page 21](#)

For information on NetVanta 3148/4148 Series configuration for a specific application, refer to the configuration guides provided on the [ADTRAN Support Community](#). For details on the command line interface (CLI), refer to the [AOS Command Reference Guide](#). All other related documents are also available online at <http://supportcommunity.adtran.com>.

2. PHYSICAL DESCRIPTION

The NetVanta 3148/4148 Series unit is a fixed-port Ethernet router designed for high-performance Ethernet solutions, focusing on higher bandwidth applications (up to 1Gbps) for Layer 3 Virtual Private Network (VPN) services and alternatives to T1 solutions. It provides a cost-effective option for branch office termination of carrier services over MPLS or Ethernet copper/fiber connections by offering 8 switchable Gigabit Ethernet Media ports and 4 routed Gigabit Ethernet system ports.

The NetVanta 3148/4148 Series unit provides two routed 10/100/1000Base-T combination copper/SFP Ethernet ports and two routed 10/100/1000Base-T copper Ethernet ports, as well as eight 10/100/1000Base-T access switch ports that provide Cisco legacy, 802.3af, and 802.3at PoE options. IPsec VPN support is included with the ADTRAN Operating System (AOS) Enhanced Feature Pack.

SFP Module Slots

The NetVanta 3148/4148 Series has two small form-factor pluggable (SFP) slots that accept a number of industry standard SFP modules. The SFP modules provide Gigabit Ethernet fiber connectivity for high-speed uplinks. For a list of supported SFP modules, visit the ADTRAN website at <http://www.adtran.com>.

Power Over Ethernet

The NetVanta 3148 PoE and NetVanta 4148 PoE units provide PoE. PoE provides the ability to detect attached powered devices (PDs) and deliver 48 VDC to PD via Ethernet cabling. The NetVanta 3148/4148 PoE Series is fully compliant with the IEEE 802.3af PoE and IEEE 802.3at PoE+ standards. By default, the PoE router discovers and provides power to IEEE-compliant PDs. The NetVanta 3148/4148 Series also supports legacy PDs.

The NetVanta 3148/4148 PoE Series has a PoE budget of 200 W. Caution should be taken not to add greater than 200 W of load from powered devices. A 200 W PoE budget enables the user to power: 8 ports at 15.4 W each, 6 ports at 25.5 W each, or any combination as long as the sum of load is less than 200 W. The NetVanta 3148/4148 PoE Series can also provide a reduced PoE budget of 7 W to all 8 ports (for a total of 56 W PoE).

Shipping Contents

Each NetVanta 3148/4148 Series unit is shipped in its own cardboard shipping carton. Open each carton carefully, and avoid deep penetration into the carton with sharp objects.

After unpacking the unit, inspect it for possible shipping damage. If the equipment has been damaged in transit, immediately file a claim with the carrier and contact ADTRAN Customer Service (refer to the [Support](http://www.adtran.com/support) page on the ADTRAN website at <http://www.adtran.com/support>).

Domestic and international shipments of the NetVanta 3148/4148 Series include the following items:

- NetVanta 3148/4148 base unit
- Set of 19-inch mounting brackets (P/N 3265479-3E@E)
- Set of 4 rubber mounting feet
- Six mounting screws
- AC power cord
- Quick start guide

NetVanta 3148/4148 Series Front Panel Design

The NetVanta 3148/4148 Series and NetVanta 3148/4148 PoE Series front panels are shown below along with a description of all connectors and interfaces.

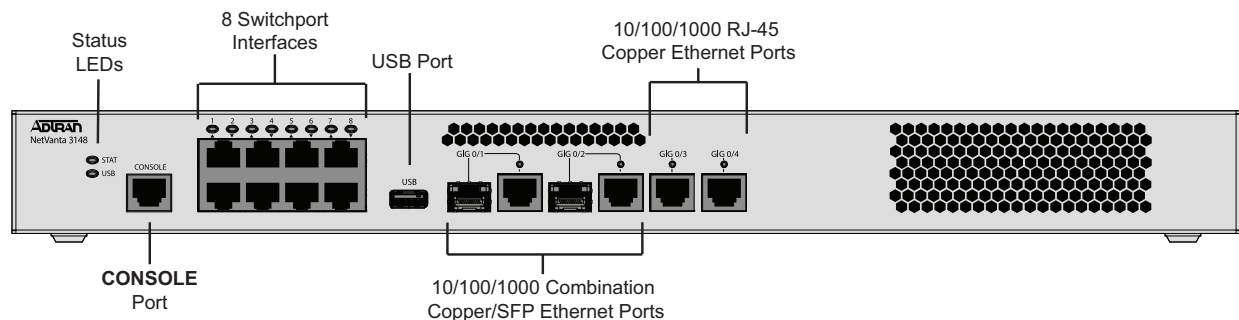

Figure 1. NetVanta 3148/4148 Front Panel Layout (non-PoE)

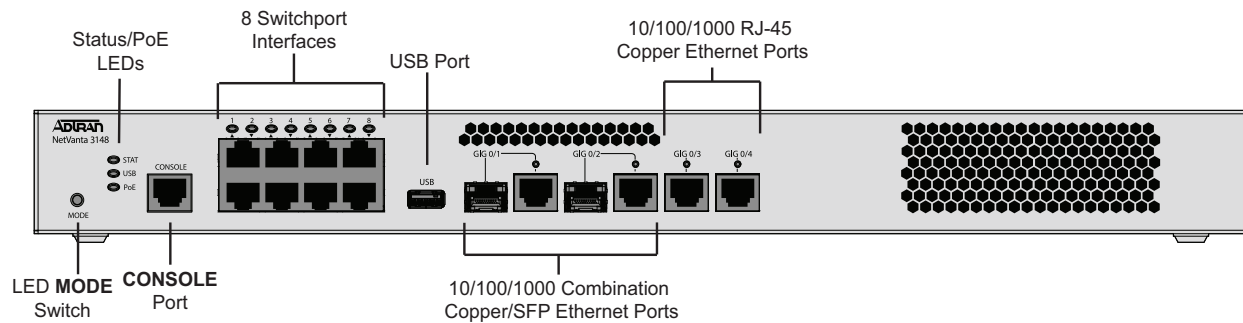

Figure 2. NetVanta 3148/4148 Front Panel Layout (PoE)

LED MODE Switch (PoE Models Only)

The LED MODE switch is located on the left side of the unit and is used to toggle ports 1 through 8 between individual port link status and PoE status display modes.

Status LEDs

The **STAT** LED indicates the unit's status. The **USB** LED reflects the status of the USB interface. The **GIG 0/1** through **GIG 0/4** LEDs reflect the status of the 10/100/1000Base-T Ethernet interfaces, and the 1 through 8 LEDs reflect the status of the 10/100/1000Base-T Ethernet switch interfaces. The **PoE** LED (available on NetVanta 3148/4148 PoE models only) indicates that port LEDs 1 through 8 are displaying PoE status. See the [Table 1 on page 12](#) for LED behaviors.

CONSOLE Interface

The **CONSOLE** interface is an EIA-232 serial port (DCE) which provides for local management and configuration (via an RJ-45 connector). See [Table A-3 on page 23](#) for the CONSOLE interface pinouts.

8 Switch Port Interfaces

Ports 1 through 8 are RJ-45 connectors used to access the fully managed 10/100/1000Base-T Ethernet switch.

USB Interface (Reserved for future use)

The USB port (**USB**) port is a USB 2.0 or 3.0 interface designed for communicating with the unit and providing additional storage. The USB status LED is located below the **STAT** LED.

2 Routed 10/100/1000Base-T Combination Copper/SFP Ethernet Interfaces

The Gigabit Ethernet ports (**GIG 0/1** and **GIG 0/2**) consist of one RJ-45 and one SFP slot for connectivity over copper or SFP connectors. (Use either the RJ-45 connector *or* the SFP slot. The copper slot has precedence). See [Table A-1 on page 22](#) for the Ethernet interface pinouts. The status LEDs are located above each interface.

2 Routed 10/100/1000Base-T Copper Ethernet Interfaces

The Gigabit Ethernet ports (**GIG 0/3** and **GIG 0/4**) consist of one RJ-45 connector for copper connections. The status LED is located above the interface.

NetVanta 3148/4148 Series Rear Panel Design

The NetVanta 3148/4148 Series rear panel is shown below along with a description of all connectors and interfaces. The NetVanta 3148 rear panel is shown below. [Appendix A on page 22](#) provides pinouts.

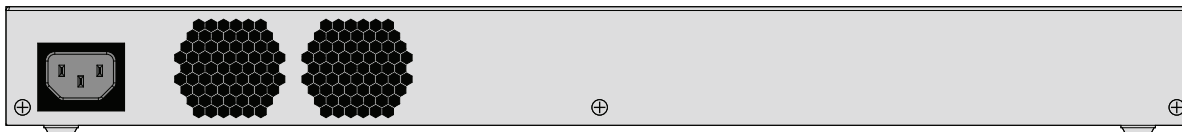

Figure 3. NetVanta 3148/4148 Series Rear Panel Layout

Power Connector

The NetVanta 3148/4148 Series products have universal 120 - 240 VAC power supplies and are shipped with the appropriate AC power cable. Please refer to [Supplying Power to the Unit on page 20](#) for connection details.

NetVanta 3148/4148 Series Front Panel LEDs

[Table 1](#) describes the NetVanta 3148/4148 Series front panel LEDs.

Table 1. NetVanta 3148/4148 Series Front Panel LEDs

LED	Color	Indication
STAT	Green (flashing)	The unit is powering up. On power up the STAT LED flashes rapidly for five seconds, during which time the user can escape to boot mode.
	Green (solid)	The power is on and self-test passed.
	Red (solid)	The power is on, but the self-test failed or the boot mode (if applicable) code could not be booted.
USB (Reserved for future use)	Off	Interface is shut down or not connected.
	Green (solid)	A supported device is connected.
	Amber (flashing)	There is activity on the link.
	Red (solid)	An alarm condition is occurring on the USB port, or there is a failure.
PoE (PoE models only)	Off	PoE status is not being displayed.
	Green	PoE is selected. The port LEDs are displaying PoE status.
GIG (0/1 through 0/4)	Off	The port is administratively disabled or does not have link.
	Green (solid)	The port is enabled and the link is up.
	Amber (flashing)	The port has activity (transmit or receive).
SWITCH (1 through 8, when PoE MODE is OFF)	Off	The port is administratively disabled or does not have link.
	Green (solid)	The port is enabled and the link is up.
	Amber (flashing)	The port has activity (transmit or receive).
SWITCH (1 through 8, when PoE MODE is ON)	Off	The port is not delivering power.
	Green (solid)	The port is delivering power.
	Red (solid)	The port has detected a PoE fault.

3. FEATURES AND SPECIFICATIONS

The NetVanta 3148/4148 Series is a fixed port router designed to support high-performance Ethernet solutions, significantly improve application performance, provide routable Gigabit Ethernet interfaces for WAN connections and Gigabit Ethernet switchports for LAN connections, and support future IDS/IPS security features.

Physical Interfaces

- Two routed 10/100/1000Base-T combination copper and SFP interfaces
- Two routed 10/100/1000Base-T copper interfaces
- Eight 10/100/1000Base-T Gigabit Ethernet switchports
- EIA-232 Console interface for VT-100 terminal configuration
- A single-type A USB 2.0 or 3.0 interface

Processor and Memory

NetVanta 3148 Series

- High-performance Linux-based 2-core processor
- DRAM: 1 GB
- Flash: 1 GB
- Hardware encryption engine embedded

NetVanta 4148 Series

- High-performance Linux-based 4-core processor
- DRAM: 2 GB
- Flash: 1 GB
- Hardware encryption engine embedded

Protocols

- eBGP/iBGP
- Open Shortest Path First (OSPF)
- RIP (v1 and v2)
- GRE
- IGMP v2
- Layer 3 Backup
- Multi-VRF CE
- PPP
- PAP and CHAP
- Multihoming
- VRRP
- LLDP/LLDP-MED

Management and Utilities

- Auto-Configuration
- AOS command line interface (CLI)

- ADTRAN n-Command® Managed Service Platform (MSP)
- Simple Network Management Protocol version 3 (SNMPv3)
- SYSLOG logging
- Telnet, craft/console port, SSH, ping, trace route, NTP
- TCL scripting
- Policy statistics
- Email alerts (SMTP)
- Flash provisioning
- FTP server support
- Packet capture

LEDs

- Status
- USB
- PoE (depending on model)
- GIG 0/1 through GIG 0/4
- Switchports 1 through 8

Layer 3 Quality of Service (QoS)

- Low Latency Queuing, Weighted Fair Queuing (WFQ), and Class-based WFQ
- DiffServ packet marking and recognition
- Frame Relay fragmentation
- Traffic monitoring (NetFlow 9)

Security

Firewall

- Stateful inspection firewall
- Denial of service (DoS) protection
- Access control lists (ACLs)
- Application level gateways (ALGs)

Network Address Translation

- Network address translation (NAT) (1:1, many:1) and 1:1 port translation
- NAT-compatible SIP ALG

Secure Management

- Multi-level access control
- TACACS+
- RADIUS AAA
- SSH CLI and SSL GUI

Content Filtering

- Inherent URL filter
- Top website reports

- Integration with Websense®

Virtual Private Network (VPN) (Optional)

- IPsec Tunnel Mode: Tunnels 1,000
- Encryption: DES, 3DES, and AES
- Authentication Mechanisms:
 - XAUTH Secure ID
 - X.509 digital certificates
 - DSS Signatures
 - Preshared keys

Ethernet Features

- IEEE 802.1p priority marking
- IEEE 802.1d dynamic/transparent bridging
- IEEE 802.1Q virtual local area network (VLAN) tagging
- IEEE 802.3u Ethernet
- Network monitoring enhancements

Environment

- Operating Temperature: 0°C to 50°C (32°F to 113°F)
- Storage Temperature: -40°C to 70°C (-4°F to 158°F)
- Relative Humidity: Up to 95 percent, noncondensing

Physical and Input Power

- Chassis: 1U high metal enclosure
- Input Voltage: 110-240 VAC, 50/60 Hz

Agency Approvals

- FCC Part 15, Class A
- NRTL Safety Listed
- IEC/EN 62368-1
- AS/NZS 60950.1/62368.1
- CE Mark
- ETSI 300 019
- RoHS
- ITU-T K.21

4. UNIT INSTALLATION

The instructions and guidelines provided in this section cover hardware installation topics, such as tabletop, wall, and rack mounting and powering the units. These instructions are presented as follows:

- [Mounting Options on page 17](#)
- [Supplying Power to the Unit on page 20](#)
- [Installing SFP Modules in the Unit on page 21](#)

For information on router configuration for a specific application, refer to the configuration guides provided on the [ADTRAN Support Community](#). For details on the command line interface (CLI), refer to the [AOS Command Reference Guide](#). All other related documents are also available online at <https://supportcommunity.adtran.com>.

WARNING

- *To prevent electrical shock, do not install equipment in a wet location or during a lightning storm.*
- *Pour prévenir les chocs électriques, n'installez pas d'équipement dans un endroit humide ou lors d'un orage.*



CAUTION

- *The NetVanta 3148/4148 Series is intended to be installed, maintained, and serviced by qualified service personnel only and should be installed in a restricted access location.*
- *The product is intended for indoor use only. Ethernet, PoE cables, and attached equipment are intended for use within the same building with equipotential bonding, and not intended to be placed in separate buildings or structures. Failure to deploy as described could result in permanent damage from lightning or other electrical events and voids the warranty. If it is necessary to connect the ports to remote outdoor equipment or between structures then add an appropriate protection device per the following:*
 - *ADTRAN's Ethernet Port Protection Device (EPPD) (P/N 1700502G1) must be connected between the unit and the outside plant cable. Use of any Ethernet protector other than ADTRAN's for this purpose will void the user's warranty.*
 - *ADTRAN's NetVanta PoE Protector/Injector (P/N 1702595F15) must be connected between the unit and the outside plant cable. Use of any PoE protector other than ADTRAN's for this purpose will void the user's warranty.*



- *La série NetVanta 3148/4148 est destinée à être installée, entretenue et entretenue uniquement par du personnel de service qualifié et doit être installée dans un endroit à accès restreint.*
- *Le produit est destiné à une utilisation en intérieur uniquement. Les câbles Ethernet, PoE et les équipements connectés sont destinés à être utilisés dans le même bâtiment avec une liaison équipotentielle et ne sont pas destinés à être placés dans des bâtiments ou des structures séparés. Le non-déploiement tel que décrit peut entraîner des dommages permanents dus à la foudre ou à d'autres événements électriques et annule la garantie. S'il est nécessaire de connecter les ports à un équipement extérieur distant ou entre des structures, ajoutez un dispositif de protection approprié conformément aux éléments suivants:*
 - *Le dispositif de protection de port Ethernet (EPPD) d'ADTRAN (P/N 1700502G1) doit être connecté entre l'unité et le câble extérieur de l'installation. L'utilisation de tout protecteur Ethernet autre qu'ADTRAN à cette fin annulera la garantie de l'utilisateur.*
 - *Le protecteur / injecteur NetVanta PoE d'ADTRAN (P/N 1702595F15) doit être connecté entre l'unité et le câble extérieur de l'installation. L'utilisation de tout protecteur PoE autre qu'ADTRAN à cette fin annulera la garantie de l'utilisateur.*



Electronic modules can be damaged by static electrical discharge. Before handling modules, put on an antistatic discharge wrist strap to prevent damage to electrical components. Place modules in antistatic packing material when transporting or storing. When working on modules, always place them on an approved antistatic mat that is electrically grounded.

Equipment Required

The customer-provided tools required for the hardware installation of the NetVanta are:

- Ethernet cables
- Network cables
- Phillips-head screwdriver (rackmount and wallmount applications only)
- Drill and drill bit set (wallmount applications only)



To access the CLI of the NetVanta, you will also need a PC with terminal emulation software and a console port cable. Instructions on how to access the CLI are available in the quick start guide shipped with your unit or online at [ADTRAN's Support Community](#).

Mounting Options

The unit may be installed in tabletop, rackmount, or wallmount configurations. The following sections provide step-by-step instructions for all mounting options.

Tabletop Mounting the NetVanta

By following these instructions exactly, the NetVanta can be safely mounted on a desk or tabletop.

 <p>CAUTION</p>	<ul style="list-style-type: none"> • <i>Desk or shelf mounting of the equipment should be such that the amount of air flow required for safe operation of the equipment is not compromised. Allow 1-inch clearance on the top and sides of the unit for sufficient air flow.</i> • <i>Le montage de l'équipement sur le bureau ou sur l'étagère doit être tel que la quantité d'air le débit nécessaire au bon fonctionnement de l'équipement n'est pas compromis. Autoriser 1 pouce l'autorisation sur le dessus et les côtés de l'appareil pour un débit d'air suffisant.</i>
---	---

Instructions for Mounting the NetVanta on a Desk or Shelf	
Step	Action
1	Verify that the desk or shelf is sturdy enough to support the switch.
2	Attach the four adhesive rubber feet to the bottom of the switch.
3	Proceed to the steps given in Supplying Power to the Unit on page 20 .

Rack Mounting the NetVanta

The NetVanta is a 1U-high, rack-mountable unit that can be installed in a 19-inch equipment rack. The following steps guide you in mounting the NetVanta into a rack.

 <p>CAUTION</p>	<ul style="list-style-type: none"> • <i>If installed in a closed or multi-unit rack assembly, the operating ambient temperature of the rack environment may be greater than room ambient temperature. Therefore, consideration should be given to installing the equipment in an environment compatible with the maximum ambient temperature specified by the manufacturer.</i> • <i>Installation of the equipment in a rack should be such that the amount of air flow required for safe operation of the equipment is not compromised.</i> • <i>Be careful not to compromise the stability of the equipment mounting rack when installing this product.</i> • <i>Consideration should be given to the connection of the equipment to the supply circuit and the effect that overloading the circuit might have on overcurrent protection and supply wiring. Appropriate consideration of equipment nameplate ratings should be used when addressing this concern.</i> • <i>Reliable grounding of rack-mounted equipment should be maintained. Particular attention should be given to supply connections other than direct connections to the branch circuit (e.g., use of power strips).</i>
---	--

Instructions for Rack Mounting the NetVanta	
Step	Action
1	Attach the rackmount brackets in the appropriate position using the supplied screws.
2	To allow proper grounding, scrape the paint from the rack around the mounting holes where the NetVanta will be positioned.
3	Position the NetVanta in a stationary equipment rack allowing 1U space above the unit for ventilation.
4	Have an assistant hold the unit in position as you install two mounting bolts through the unit's brackets and into the equipment rack using a #2 Phillips-head screwdriver.
5	Proceed to the steps given in Supplying Power to the Unit on page 20 .

Wall Mounting the NetVanta

By following these instructions exactly, the NetVanta can be safely mounted on the wall.

 <p>CAUTION</p>	<ul style="list-style-type: none"> To avoid damaging the unit, use only the screws included in the shipment when attaching mounting ears to the chassis. When wall mounting the NetVanta, care must be taken not to damage the power cord. Do not attach the power cord to the building surface or run it through walls, ceilings, floors, or openings in the building structure. The socket-outlet must be installed near the equipment and must be easily accessible.
---	--

Instructions for Wall Mounting the NetVanta	
Step	Action
1	Attach the 19-inch rack mounting brackets rotated 90 degrees so the rackmount tab (two screw holes) is parallel with the bottom of the unit (see Figure 4 on page 20).
2	Decide on a location for the NetVanta, keeping in mind that the unit needs to be mounted at or below eye-level so that the LEDs are viewable. The NetVanta 3148/4148 Series can only be wall mounted with the front panel facing towards the left (see Figure 4 on page 20).
3	Prepare the mounting surface by attaching a board (typically plywood, 3/4-inch to 1-inch thick) to a wall stud using #6 to #10 (2.5-inch or greater in length) wood screws. Important! Mounting to a stud ensures stability. Using sheetrock anchors may not provide sufficient long-term stability.
4	Have an assistant hold the unit in position as you install two #6 to #10 (1-inch or greater in length) wood screws through the unit's brackets and into the mounted board (see Figure 4 on page 20).
5	Proceed to the steps given in Supplying Power to the Unit on page 20 .

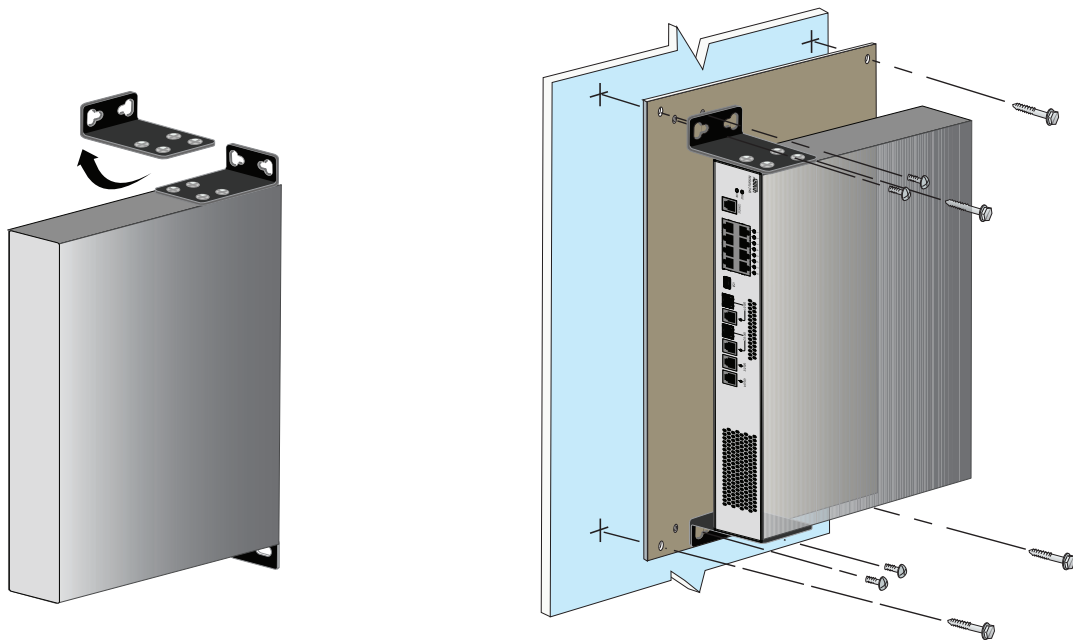

Figure 4. Wallmount Installation

Supplying Power to the Unit

The NetVanta 3148/4148 Series units come equipped with an 120 - 240 VAC power supply for connecting to the proper power receptacles. All necessary power cords are shipped with the units.



- *The installation of this product must comply with the national, state and local electrical code requirements, as applicable. The AC branch circuit overcurrent protection must be a fuse or circuit breaker rated 125 VAC, 20 Amps maximum or 250 VAC, 16 Amps maximum. A readily accessible disconnect device that is suitably approved and rated must be incorporated in the field wiring.*
- *The AC branch circuit socket-outlet must be installed near the equipment and must be easily accessible.*
- *It is recommended that an external AC Surge Protection Device be installed at the AC input connection to the local AC-Powered product. The Surge Protection device should provide L-N, L-G, and N-G protection. It is also recommended that the device contains a visual 'GOOD' indicator.*

Instructions for Powering the NetVanta 3148/4148 Series

Step	Action
1	With the flat side up, fully insert the AC power cord into the AC power receptacle on the rear panel of the unit.
2	Insert the other end of the power cable into a properly grounded power source.
3	Confirm that the power is connected properly. The STAT LED should be ON .

Installing SFP Modules in the Unit

The NetVanta 3148/4148 Series units supports two SFP ports on the front of the unit. SFP modules can be installed or removed without having to power off the unit.

Instructions for Installing SFP Modules in the NetVanta 3148/4148 Series	
Step	Action
1	Insert the module into the appropriate SFP port.
2	Press firmly to ensure that the module seats properly into the connector. There will be an audible click when the SFP module is seated correctly.



The SFP ports are intended for use only with Class 1, safety listed/approved optical transceiver products, rated 3.3 VDC.

Your NetVanta unit is now ready to be configured and connected to the network. For information on configuration for a specific application, refer to the configuration guides provided on the [ADTRAN Support Community](#). For details on the command line interface (CLI), refer to the [AOS Command Reference Guide](#). All other related documents are also available online at <https://supportcommunity.adtran.com>.

APPENDIX A. CONNECTOR PIN DEFINITIONS

The following tables provide the pin assignments for the NetVanta 3148/4148 Series base units.



The Gigabit Ethernet port pinouts apply to all four Copper Gigabit Ethernet ports; only one example is displayed in the table. The switch port pinouts apply for all eight switch ports; only one example is displayed in the table.

Base Unit Pinouts

Table A-1. Copper Gigabit Ethernet Port Pinouts

Pin	Signal	Description
1	RJ_GBE1_MDIA_+	GBE port 1 Media Dependent Interface A (+)
2	RJ_GBE1_MDIA_-	GBE port 1 Media Dependent Interface A (-)
3	RJ_GBE1_MDIB_+	GBE port 1 Media Dependent Interface B (+)
4	RJ_GBE1_MDIC_+	GBE port 1 Media Dependent Interface C (+)
5	RJ_GBE1_MDIC_-	GBE port 1 Media Dependent Interface C (-)
6	RJ_GBE1_MDIB_-	GBE port 1 Media Dependent Interface B (-)
7	RJ_GBE1_MDID_+	GBE port 1 Media Dependent Interface D (+)
8	RJ_GBE1_MDID_-	GBE port 1 Media Dependent Interface D (-)

Table A-2. Switch Port Pinouts

Pin	Signal	Description
A1	RJ_SWP2_MDIA_+	Switch port 2 Media Dependent Interface A (+)
A2	RJ_SWP2_MDIA_-	Switch port 2 Media Dependent Interface A (-)
A3	RJ_SWP2_MDIB_+	Switch port 2 Media Dependent Interface B (+)
A4	RJ_SWP2_MDIB_-	Switch port 2 Media Dependent Interface B (-)
A5	RJ_SWP2_MDIC_+	Switch port 2 Media Dependent Interface C (+)
A6	RJ_SWP2_MDIC_-	Switch port 2 Media Dependent Interface C (-)
A7	RJ_SWP2_MDID_+	Switch port 2 Media Dependent Interface D (+)
A8	RJ_SWP2_MDID_-	Switch port 2 Media Dependent Interface D (-)
1	GND	Shield mounting pin (connected to ground (GND))
2	GND	Shield mounting pin (connected to GND)
3	GND	Shield mounting pin (connected to GND)
4	GND	Shield mounting pin (connected to GND)

Table A-2. Switch Port Pinouts

Pin	Signal	Description
5	GND	Shield mounting pin (connected to GND)

Table A-3. Console Port Pinouts

Pin	Name	Description
1	DCD	Data Carrier Detect (output)
2	TXD	Receive Data (output)
3	RXD	Transmit Data (input)
4	DTR	Data Terminal Ready (input)
5	GND	Signal Ground
6	DSR	Data Set Ready (output)
7	RTS	Request to Send (input)
8	CTS	Clear to Send (output)
9	—	Unused

Table A-4. USB Port Pinouts

Pin	Signal	Description
1	VBUS	5 V USB Bus supply
2	D-	USB 2.0 Data (-)
3	D+	USB 2.0 Data (+)
4	GND	GND
S1	SHIELD	Connector shield (connected to ground (GND))
S2	SHIELD	Connector shield (connected to GND)