

Serie | 2 Ovens
**Oven
HBN331E4B**

The built-in oven with special hot air function: you achieve perfect baking and roasting results on up to two levels simultaneously.

- Hotair creates perfect results thanks to optimal distribution of heat on up to 2 levels simultaneously.
- **Flap door:** for especially convenient opening and closing of the oven door.
- **Energy efficiency class A:** Best baking results with low energy consumption.

Technical Data

Color / Material Front :	Stainless steel
Construction type :	Built-in
Integrated Cleaning system :	No
Required niche size for installation (HxWxD) :	575-597 x 560 x 550
Dimensions of the product (mm) :	595 x 595 x 548
Dimensions of the packed product (HxWxD) (mm) :	665 x 665 x 684
Control Panel Material :	Metal
Door Material :	Glass
Net weight (kg) :	31.0
Usable volume of cavity (l) :	66
Cooking method :	3D hot air, Defrost, Full width variable grill, Hot air grilling
First cavity material :	Enamelled
Temperature control :	mechanical
Number of interior lights :	1
Approval certificates :	CE, KEMA
EAN code :	4242002810751
Number of cavities (2010/30/EC) :	1
Energy efficiency class - NEW (2010/30/EC) :	A
Energy consumption per cycle forced air convection (2010/30/EC) :	0.82
Energy efficiency index (2010/30/EC) :	98.8
Electrical connection rating (W) :	2350
Current (A) :	13
Voltage (V) :	220-240
Frequency (Hz) :	50; 60
Plug type :	fixed connection, no plug

Included accessories

- 1 x insert grid
- 1 x combination grid
- 1 x universal pan



4 242002 810751

Serie | 2 Ovens

Oven

HBN331E4B

The built-in oven with special hot air function: you achieve perfect baking and roasting results on up to two levels simultaneously.

Key Information

- Mechanical control
- Drop down door

Design

- Rotary dial
- Straight bar handle

Features

- Electronic clock timer
- 1 interior light
- Round light
- Control panel lock
- Cavity inner surface: Enamel
- Smooth enamelled oven interior
- 4 shelf positions
- Full glass inner door
- Info button

Programmes/functions

- Oven with 4 heating methods: Hotair grilling, defrost

Performance/technical information

- Cavity volume: 66 litre
- Integral cooling fan
- Stainless-steel fan
- Total connected load electric: 2.35 KW
- Appliance dimension (hxwx): 595 mm x 595 mm x 548 mm
- Niche dimension (hxwx): 575 mm - 597 mm x 560 mm - 568 mm x 550 mm
- Please reference the built-in dimensions provided in the installation drawing
- Energy efficiency rating (acc. EU Nr. 65/2014):
Energy consumption per cycle in conventional mode: 98.8
Energy consumption per cycle in fan-forced convection mode: 0.82 kwh
Number of cavities: 1
Heat source: electrical
Cavity volume: 66 litre

Standard accessories

- 1 x insert grid, 1 x combination grid, 1 x universal pan

Serie | 2 Ovens

Oven
HBN331E4B

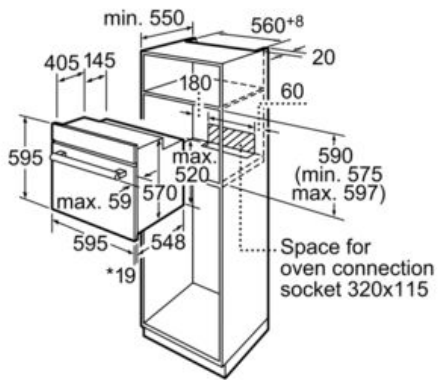

*20 mm for metal fascias
Measurements in mm

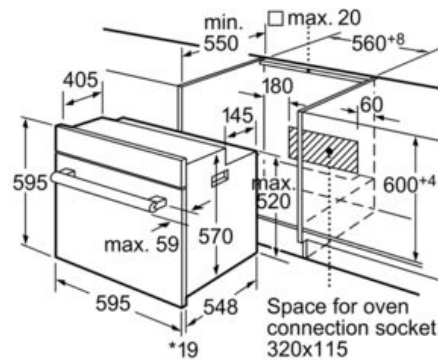

*20 mm for metal fascias
Measurements in mm

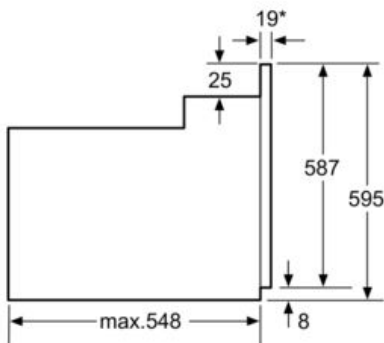

* 20 mm for metal fascias
Dimensions in mm