

Digital HD Video Camera Recorder

Operating Guide



Please also refer to :

<http://www.sony.net/SonyInfo/Support/>

Table of contents
Getting started
Recording/Playback
Advanced operations
Editing
Saving movies and photos with a computer
Saving images on an external media device
Customizing your camcorder
Others/Index

HANDYCAM.



AVCHD
Progressive

HDMI™
HIGH DEFINITION MULTIMEDIA INTERFACE

Read this first

Before operating the unit, please read this manual thoroughly, and retain it for future reference.

Owner's Record

The model and serial numbers are located on the bottom. Record the serial number in the space provided below. Refer to these numbers whenever you call upon your Sony dealer regarding this product.

Model No. HDR- _____

Serial No. _____

Model No. AC- _____

Serial No. _____

WARNING

To reduce the risk of fire or electric shock,

1) do not expose the unit to rain or moisture.

2) do not place objects filled with liquids, such as vases, on the apparatus.

Do not expose the batteries to excessive heat such as sunshine, fire or the like.



This symbol is intended to alert the user to the presence of uninsulated “dangerous voltage” within the product’s enclosure that may be of sufficient magnitude to constitute a risk of electric shock to persons.



This symbol is intended to alert the user to the presence of important operating and maintenance (servicing) instructions in the literature accompanying the appliance.

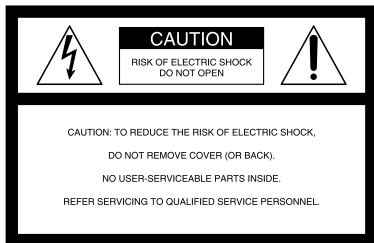

IMPORTANT SAFETY INSTRUCTIONS

SAVE THESE INSTRUCTIONS.

DANGER - TO REDUCE THE RISK OF FIRE
OR ELECTRIC SHOCK,
CAREFULLY FOLLOW THESE
INSTRUCTIONS.

- Read these instructions.
- Keep these instructions.
- Heed all warnings.
- Follow all instructions.
- Do not use this apparatus near water.
- Clean only with dry cloth.
- Do not block any ventilation openings. Install in accordance with the manufacturer's instructions.
- Do not install near any heat sources such as radiators, heat registers, stoves, or other apparatus (including amplifiers) that produce heat.
- Do not defeat the safety purpose of the polarized or grounding-type plug. A polarized plug has two blades with one wider than the other. A grounding type plug has two blades and a third grounding prong. The wide blade or the third prong are provided for your safety. If the provided plug does not fit into your outlet, consult an electrician for replacement of the obsolete outlet.
- Protect the power cord from being walked on or pinched particularly at plugs, convenience receptacles, and the point where they exit from the apparatus.
- Only use attachments/accessories specified by the manufacturer.
- Use only with the cart, stand, tripod, bracket, or table specified by the manufacturer, or sold with the apparatus. When a cart is used, use caution when moving the cart/apparatus combination to avoid injury from tip-over.



- Unplug this apparatus during lightning storms or when unused for long periods of time.
- Refer all servicing to qualified service personnel. Servicing is required when the apparatus has been damaged in any way, such as power-supply cord or plug is damaged, liquid has been spilled or objects have fallen into the apparatus, the apparatus has been exposed to rain or moisture, does not operate normally, or has been dropped.
- If the shape of the plug does not fit the power outlet, use an attachment plug adaptor of the proper configuration for the power outlet.

Representative plug of power supply cord of countries/regions around the world.



A Type
(American Type)



B Type
(British Type)



BF Type
(British Type)



B3 Type
(British Type)



C Type
(CEE Type)



SE Type
(CEE Type)



O Type
(Ocean Type)

The representative supply voltage and plug type are described in this chart.

Depend on an area, Different type of plug and supply voltage are used.

Attention: Power cord meeting demands from each country shall be used.

- For only the United States
Use a supplied power cord.

Europe

Countries/regions	Voltage	Frequency (Hz)	Plug type
Austria	230	50	C
Belgium	230	50	C
Czech	220	50	C
Denmark	230	50	C
Finland	230	50	C
France	230	50	C
Germany	230	50	C
Greece	220	50	C
Hungary	220	50	C
Iceland	230	50	C
Ireland	230	50	C/BF
Italy	220	50	C
Luxemburg	230	50	C
Netherlands	230	50	C
Norway	230	50	C
Poland	220	50	C
Portugal	230	50	C
Romania	220	50	C
Russia	220	50	C
Slovak	220	50	C
Spain	127/230	50	C
Sweden	230	50	C
Switzerland	230	50	C
UK	240	50	BF

Asia

Countries/regions	Voltage	Frequency (Hz)	Plug type
China	220	50	A
Hong Kong	200/220	50	BF
India	230/240	50	C
Indonesia	127/230	50	C
Japan	100	50/60	A
Korea (rep)	220	60	C
Malaysia	240	50	BF
Philippines	220/230	60	A/C
Singapore	230	50	BF
Taiwan	110	60	A

Countries/regions	Voltage	Frequency (Hz)	Plug type
Thailand	220	50	C/BF
Vietnam	220	50	A/C

Oceania

Countries/regions	Voltage	Frequency (Hz)	Plug type
Australia	240	50	O
New Zealand	230/240	50	O

North America

Countries/regions	Voltage	Frequency (Hz)	Plug type
Canada	120	60	A
USA	120	60	A

Central America

Countries/regions	Voltage	Frequency (Hz)	Plug type
Bahamas	120/240	60	A
Costa Rica	110	60	A
Cuba	110/220	60	A/C
Dominican (rep)	110	60	A
El Salvador	110	60	A
Guatemala	120	60	A
Honduras	110	60	A
Jamaica	110	50	A
Mexico	120/127	60	A
Nicaragua	120/240	60	A
Panama	110/220	60	A

South America

Countries/regions	Voltage	Frequency (Hz)	Plug type
Argentina	220	50	C/BF/O
Brazil	127/220	60	A/C
Chile	220	50	C
Colombia	120	60	A
Peru	220	60	A/C
Venezuela	120	60	A

Middle East

Countries/regions	Voltage	Frequency (Hz)	Plug type
Iran	220	50	C/BF
Iraq	220	50	C/BF
Israel	230	50	C
Saudi Arabia	127/220	50	A/C/BF
Turkey	220	50	C
UAE	240	50	C/BF

Africa

Countries/regions	Voltage	Frequency (Hz)	Plug type
Algeria	127/220	50	C
Congo (dem)	220	50	C
Egypt	220	50	C
Ethiopia	220	50	C
Kenya	240	50	C/BF
Nigeria	230	50	C/BF
South Africa	220/230	50	C/BF
Tanzania	230	50	C/BF
Tunisia	220	50	C

CAUTION

Battery pack

If the battery pack is mishandled, the battery pack can burst, cause a fire or even chemical burns. Observe the following cautions.

- Do not disassemble.
- Do not crush and do not expose the battery pack to any shock or force such as hammering, dropping or stepping on it.
- Do not short circuit and do not allow metal objects to come into contact with the battery terminals.
- Do not expose to high temperature above 60°C (140°F) such as in direct sunlight or in a car parked in the sun.
- Do not incinerate or dispose of in fire.
- Do not handle damaged or leaking lithium ion batteries.
- Be sure to charge the battery pack using a genuine Sony battery charger or a device that can charge the battery pack.
- Keep the battery pack out of the reach of small children.
- Keep the battery pack dry.
- Replace only with the same or equivalent type recommended by Sony.
- Dispose of used battery packs promptly as described in the instructions.

Replace the battery with the specified type only. Otherwise, fire or injury may result.

AC Adaptor

Do not use the AC Adaptor placed in a narrow space, such as between a wall and furniture.

Use the nearby wall outlet (wall socket) when using the AC Adaptor. Disconnect the AC Adaptor from the wall outlet (wall socket) immediately if any malfunction occurs while using your camcorder.

Even if your camcorder is turned off, AC power source (mains) is still supplied to

it while connected to the wall outlet (wall socket) via the AC Adaptor.

Note on the power cord (mains lead)

The power cord (mains lead) is designed specifically for use with this camcorder only, and should not be used with other electrical equipment.

Excessive sound pressure from earphones and headphones can cause hearing loss.

For customers in the U.S.A. and CANADA

RECYCLING LITHIUM-ION BATTERIES

Lithium-Ion batteries are recyclable.

You can help preserve our environment by returning your used rechargeable batteries to the collection and recycling location nearest you.



For more information regarding recycling of rechargeable batteries, call toll free 1-800-822- 8837, or visit <http://www.rbrcc.org/>

Caution: Do not handle damaged or leaking Lithium-Ion batteries.

Battery pack

This device complies with Part 15 of the FCC Rules. Operation is subject to the following two conditions:

(1) This device may not cause harmful interference, and (2) this device must accept any interference received, including interference that may cause undesired operation.

This Class B digital apparatus complies with Canadian ICES-003.

For Customers in the U.S.A.

UL is an internationally recognized safety organization.

The UL Mark on the product means it has been UL Listed.

If you have any questions about this product, you may call:

Sony Customer Information Center
1-800-222-SONY (7669)

The number below is for the FCC related matters only.

Regulatory Information

Declaration of Conformity

Trade Name: SONY

Model No.: HDR-PJ790V

Responsible Party: Sony Electronics Inc.

Address: 16530 Via Esprillo, San Diego,
CA 92127 U.S.A.

Telephone No.: 858-942-2230

This device complies with Part 15 of the FCC Rules. Operation is subject to the following two conditions: (1) This device may not cause harmful interference, and (2) this device must accept any interference received, including interference that may cause undesired operation.

CAUTION

You are cautioned that any changes or modifications not expressly approved in this manual could void your authority to operate this equipment.

Note

This equipment has been tested and found to comply with the limits for a Class B digital device, pursuant to Part 15 of the FCC Rules.

These limits are designed to provide reasonable protection against harmful

interference in a residential installation. This equipment generates, uses, and can radiate radio frequency energy and, if not installed and used in accordance with the instructions, may cause harmful interference to radio communications. However, there is no guarantee that interference will not occur in a particular installation. If this equipment does cause harmful interference to radio or television reception, which can be determined by turning the equipment off and on, the user is encouraged to try to correct the interference by one or more of the following measures:

- Reorient or relocate the receiving antenna.
- Increase the separation between the equipment and receiver.
- Connect the equipment into an outlet on a circuit different from that to which the receiver is connected.
- Consult the dealer or an experienced radio/TV technician for help.

The supplied interface cable must be used with the equipment in order to comply with the limits for a digital device pursuant to Subpart B of Part 15 of FCC Rules.

For the State of California, USA only

Perchlorate Material – special handling may apply,
See

www.dtsc.ca.gov/hazardouswaste/perchlorate
Perchlorate Material: Lithium battery contains perchlorate.

FOR CUSTOMERS IN EUROPE



Hereby, Sony Corporation, declares that this HDR-PJ780VE/PJ790VE Digital HD Video Camera Recorder is in compliance with the essential requirements and other relevant provisions of the Directive 1999/5/

EC. For details, please access the following URL: <http://www.compliance.sony.de/>

Notice for the customers in the countries applying EU Directives

This product has been manufactured by or on behalf of Sony Corporation, 1-7-1 Konan Minato-ku Tokyo, 108-0075 Japan. Inquiries related to product compliance based on European Union legislation shall be addressed to the authorized representative, Sony Deutschland GmbH, Hedelfinger Strasse 61, 70327 Stuttgart, Germany. For any service or guarantee matters, please refer to the addresses provided in the separate service or guarantee documents.

This product has been tested and found compliant with the limits set out in the EMC regulation for using connection cables shorter than 3 meters (9.8 feet).

Attention

The electromagnetic fields at the specific frequencies may influence the picture and sound of this unit.

Notice

If static electricity or electromagnetism causes data transfer to discontinue midway (fail), restart the application or disconnect and connect the communication cable (USB, etc.) again.



Disposal of Old Electrical & Electronic Equipment (Applicable in the European Union and other European countries with separate collection systems)

This symbol on the product or on its packaging indicates that this product shall not be treated as household waste. Instead it shall be handed over to the applicable collection point for the recycling of electrical and electronic equipment.

By ensuring this product is disposed of correctly, you will help prevent potential negative consequences for the environment and human health, which could otherwise be caused by inappropriate waste handling of this product. The recycling of materials will help to conserve natural resources. For more detailed information about recycling of this product, please contact your local Civic Office, your household waste disposal service or the shop where you purchased the product.



Disposal of waste batteries (applicable in the European Union and other European countries with separate collection systems)

This symbol on the battery or on the packaging indicates that the battery provided with this product shall not be treated as household waste.

On certain batteries this symbol might be used in combination with a chemical symbol. The chemical symbols for mercury (Hg) or lead (Pb) are added if the battery contains more than 0.0005% mercury or 0.004% lead.

By ensuring these batteries are disposed of correctly, you will help prevent potentially negative consequences for the environment and human health which could otherwise be caused by inappropriate waste handling of the battery. The recycling of the materials will help to conserve natural resources. In case of products that for safety, performance or data integrity reasons require a permanent connection with an incorporated battery, this battery should be replaced by qualified service staff only. To ensure that the battery will be treated properly, hand over the product at end-of-life to the applicable collection point for the recycling of electrical and electronic equipment.



For all other batteries, please view the section on how to remove the battery from

the product safely. Hand the battery over to the applicable collection point for the recycling of waste batteries.

For more detailed information about recycling of this product or battery, please contact your local Civic Office, your household waste disposal service or the shop where you purchased the product.

Notice for customers in the United Kingdom

A moulded plug complying with BS 1363 is fitted to this equipment for your safety and convenience.

Should the fuse in the plug supplied need to be replaced, a fuse of the same rating as the supplied one and approved by ASTA or BSI to BS 1362, (i.e., marked with an  or  mark) must be used.

If the plug supplied with this equipment has a detachable fuse cover, be sure to attach the fuse cover after you change the fuse. Never use the plug without the fuse cover.

If you should lose the fuse cover, please contact your nearest Sony service station.

For information on your camcorder model, see the following page:

Functions and equipment → p.11



About language setting

- Change the screen language before using the camcorder if necessary (p. 22). The on-screen displays in each local language are used for illustrating the operating procedures.

On recording

- Before starting to record, test the recording function to make sure the image and sound are recorded without any problems.
- Compensation for the contents of recordings cannot be provided, even if recording or playback is not possible due to a malfunction of the camcorder, recording media, etc.
- TV color systems differ depending on the country/region. To view your recordings on a TV, you need a TV that supports the signal format for your camcorder. For details on the signal format, refer to “How to use this manual” (p. 11).
- Television programs, films, video tapes, and other materials may be copyrighted. Unauthorized recording of such materials may be violate to the copyright laws.

Notes on use

- Do not do any of the following. If any of those are done, the recording media may be damaged, recorded images may be impossible to play back or may be lost, or other malfunctions could occur.
 - ejecting the memory card when the access lamp (p. 25) is lit or flashing
 - removing the battery pack or AC Adaptor from the camcorder, or applying mechanical shock or vibration to the camcorder when the  (Movie)/  (Photo) lamps (p. 15) or the access lamp (p. 25) are lit or flashing

- When the camcorder is connected to other devices through a USB connection and the power of the camcorder is turned on, do not close the LCD panel. The image data that has been recorded may be lost.
- Use the camcorder in accordance with local regulations.

LCD Panel , viewfinder

- The LCD screen and viewfinder are manufactured using extremely high-precision technology, so over 99.99% of the pixels are operational for effective use. However, there may be some tiny black points and/or bright points (white, red, blue, or green in color) that appear constantly on the LCD screen. These points are normal results of the manufacturing process and do not affect the recording in any way.

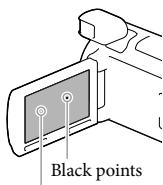

White, red, blue or green points

About this manual, illustrations and on-screen displays

- The example images used in this manual for illustration purposes are captured using a digital still camera, and therefore may appear different from images and screen indicators that actually appear on your camcorder. And, the illustrations of your camcorder and its screen indication are exaggerated or simplified for understandability.
- Design and specifications of your camcorder and accessories are subject to change without notice.

- In this manual, the internal memory of the camcorder and the memory card are called “recording media.”
- In this manual, the DVD disc recorded with high definition image quality (HD) is called AVCHD recording disc.

Learning more about the camcorder (“Handycam” User Guide)

“Handycam” User Guide is an on-line manual. Refer to it for in-depth instructions on the many functions of the camcorder.



1 Access the Sony support page.

<http://www.sony.net/SonyInfo/Support/>

2 Select your country or region.

3 Search for the model name of your camcorder within the support page.

- Check the model name on the bottom of your camcorder.

How to use this manual

In this manual, the differences in the specifications for each model are described together. If you find the description “Models with ...” like below, confirm in this chapter whether the description applies to your camcorder.

- (Models with GPS)
- (Models with the NTSC color system)

To confirm the model name of your camcorder

See the bottom of your camcorder.

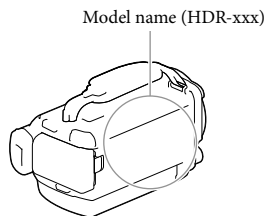

Differences in functions

Model name	Capacity of internal memory	Signal format	USB connection	GPS
HDR-PJ780E	32 GB	PAL	Output only	–
HDR-PJ780VE	32 GB	PAL	Output only	✓
HDR-PJ790	96 GB	NTSC	Input/Output	–
HDR-PJ790E	96 GB	PAL	Output only	–
HDR-PJ790V	96 GB	NTSC	Input/Output	✓
HDR-PJ790VE	96 GB	PAL	Output only	✓

Notes

- For the following items, the descriptions are explained with the model name.
 - Safety Regulation (p. 2)
 - Parts and controls (p. 14)
 - Menu lists (p. 51)
 - Specifications (p. 65)
 - Recording time of movies/number of recordable photos (p. 58)

Table of contents

Read this first	2
IMPORTANT SAFETY INSTRUCTIONS	3
Learning more about the camcorder ("Handycam" User Guide)	10
How to use this manual	11
Differences in functions	11
Parts and controls	14

Getting started

Supplied Items	18
Charging the battery pack	19
Charging the battery using your computer	20
Charging the battery pack abroad	21
Turning the power on, and setting the date and time	22
Changing the language setting	22
Preparing the recording media	25
Selecting a recording medium	25
Inserting a memory card	25

Recording/Playback

Recording	27
Recording movies	27
Shooting photos	28
Zooming	30
Playback	31

Advanced operations

Recording images with various settings	34
Selecting the image quality of movies (Recording mode)	34
Capturing smiles automatically (Smile Shutter)	34
Selecting the suitable setting automatically for the recording situation (Intelligent Auto)	35
Selecting the recording format of movies	35
Using the manual adjustment features	36
Recording information on your location (Models with GPS)	37
Playing images on a TV	37
Enjoying 5.1ch surround sound	38
Using the built-in projector	39

Editing

Editing on your camcorder.....	41
Deleting movies and photos.....	41
Dividing a movie.....	41
Capturing a photo from a movie.....	42

Saving movies and photos with a computer

Playing images on a computer.....	43
What you can do with "PlayMemories Home" software (Windows).....	43
Software for Mac.....	43
Preparing a computer (Windows).....	44
Checking the computer system.....	44
Installing the "PlayMemories Home" software in your computer.....	44
Starting the "PlayMemories Home" software.....	45

Saving images on an external media device

Creating a standard definition image quality (STD) disc with a recorder.....	46
Saving images on an external media device with high definition (HD) image quality.....	47

Customizing your camcorder

Using menus.....	50
Menu lists.....	51

Others/Index

Troubleshooting.....	55
Self-diagnosis display/Warning indicators.....	56
Recording time of movies/number of recordable photos.....	58
Expected time of recording and playback with each battery pack.....	58
Expected recording time of movies.....	58
Expected number of recordable photos.....	60
About handling of your camcorder.....	61
Specifications.....	65
END-USER LICENSE AGREEMENT FOR MAP DATA FOR VIDEO CAMERA RECORDER PRODUCTS (Models with GPS).....	68
Screen indicators.....	72
Index.....	74

Parts and controls

Figures in () are reference pages.

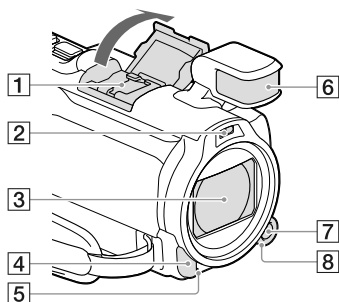

1 Multi interface shoe

mi Multi Interface Shoe

For details on compatible accessories of the Multi interface shoe, visit the Sony web site in your area, or consult your Sony dealer or local authorized Sony service facility.

Operations with other manufacturer's accessories are not guaranteed.

2 Flash/Video light

3 Lens (Carl Zeiss lens)

4 Remote sensor/Infrared port

5 Camera recording lamp (53)

The camera recording lamp lights up in red during recording. The lamp flashes when the remaining recording media capacity or battery power is low.

6 Built-in microphone

7 MANUAL button (36)

8 MANUAL dial (36)

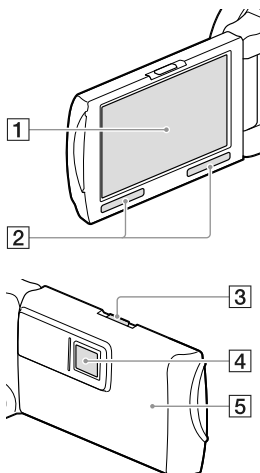

1 LCD screen/Touch panel (22, 24)

If you rotate the LCD panel 180 degrees, you can close the LCD panel with the LCD screen facing out. This is convenient during playback operations.

2 Speakers

3 PROJECTOR FOCUS lever (39)

4 Projector lens (39)

5 GPS antenna (HDR-PJ780VE/PJ790V/PJ790VE)

A GPS antenna is located in the LCD panel.

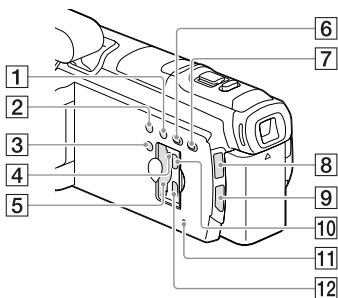

- 1** LIGHT (Video Light) button
- 2** NIGHTSHOT button
- 3** POWER button
- 4** Memory card access lamp (25)
While the lamp is lit or flashing, the camcorder is reading or writing data.

- 5** Memory card slot (25)
- 6** (View Images) button
- 7** PROJECTOR button (39)
- 8** (Movie)/ (Photo) lamp
- 9** MODE button
- 10** PROJECTOR IN jack (40)
- 11** RESET button
Press RESET using a pointed object.
Press RESET to initialize all the settings including the clock setting.

- 12** HDMI OUT jack (37)

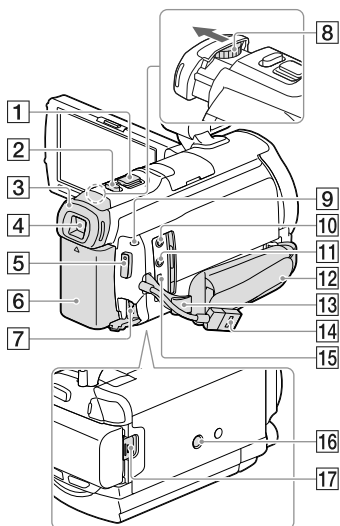

- 1** Power zoom lever (30)
- 2** PHOTO button (28)
- 3** Eyecup
- 4** Viewfinder (23)
- 5** START/STOP button (27)
- 6** Battery pack (19)
- 7** DC IN jack (19)
- 8** Viewfinder lens adjustment lever (23)
- 9** CHG (charge) lamp (19)
- 10** (microphone) jack (PLUG IN POWER)
- 11** (headphones) jack
- 12** Grip belt
- 13** Loop for a shoulder belt
- 14** Built-in USB Cable (20)
- 15** Multi/Micro USB Terminal (37)
Supports Micro USB compatible devices.
- 16**
- 17**

16 Tripod receptacle

Attach a tripod (sold separately: the length of the screw must be less than 5.5 mm (7/32 in.)).

Depending on the specifications of the tripod, your camcorder may not attach in the proper direction.

17 BATT (battery) release lever (21)

To fasten the grip belt

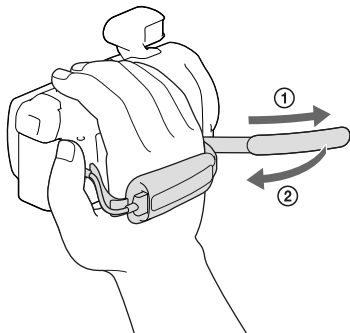

To attach the lens hood

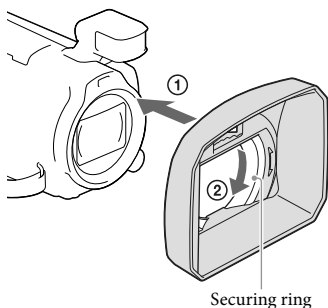

Align the lens hood with the camcorder properly (①), then turn the securing ring of the lens hood in the direction of the arrow (②).

- When attaching the lens hood, align the opening section of the lens hood with the flash-emitting section of the camcorder properly.

- To remove the lens hood, turn the securing ring of the lens hood in the opposite direction from that of the arrow.
- Remove the lens hood when you record movies using the NightShot function. If you do not do so, the shadow of the lens hood will be reflected and recorded in your movies.
- Remove the lens hood when you operate the camcorder with the supplied remote commander.

To attach the Step Down Ring

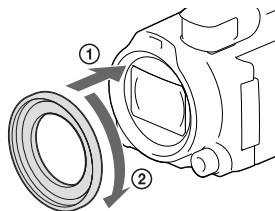

Align the Step Down Ring with the camcorder properly (①), then turn it in the direction of the arrow until the Step Down Ring is locked in place (②).

- You can change the filter diameter to 37mm (1 1/2 in.) by attaching the Step Down Ring, allowing you to use the recommended conversion lens.
- You cannot attach the wide end conversion lens/filter, if the Step Down Ring is attached.
- To remove Step Down Ring, turn it in the opposite direction from that of the arrow.

To attach the wind screen

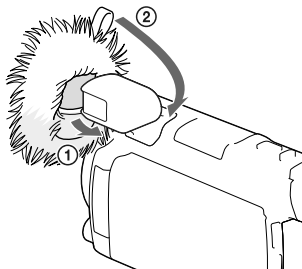

The wind screen can reduce wind noise in windy conditions.

Insert the front side of the built-in microphone into the hole at the bottom of the wind screen (1), then pull the tag on the windscreen backwards until the wind screen covers the built-in microphone (2).

- When the lens hood is attached, it may be difficult to attach the wind screen.
- Pull the tag upward to remove the wind screen.

Wireless Remote Commander

Using the wireless remote commander is helpful when projecting recorded images from your camcorder.

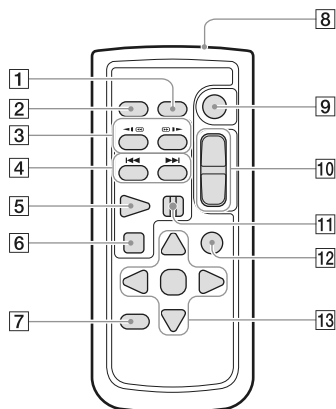

- 1 DATA CODE button (53)**
Displays the date and time, camera setting data, or coordinates (models with GPS) of the recorded images when you press this button during playback.
- 2 PHOTO button (28)**
Records as a still image the image that is displayed on the screen when this button is pressed.
- 3 SCAN/SLOW buttons (32)**
- 4 ◀◀/▶▶ (Previous/Next) buttons (31)**
- 5 PLAY button**
- 6 STOP button**
- 7 DISPLAY button (28)**
- 8 Transmitter**
- 9 START/STOP button (27)**
- 10 Power zoom buttons**
- 11 PAUSE button**
- 12 VISUAL INDEX button (31)**
Displays an Index screen during playback.
- 13 ◀/▶/▲/▼/ENTER buttons**
Displays a light blue frame on the LCD screen when you press any of these buttons. Select a desired button or an item with ◀/▶/▲/▼, then press ENTER to enter.

Supplied Items

The numbers in () indicate the supplied quantity.

Camcorder (1)

AC Adaptor (1)

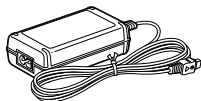

Power cord (Mains lead) (1)

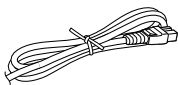

HDMI cable (1)

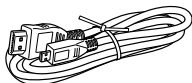

USB connection support cable (1)

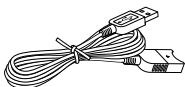

- The USB connection support cable is designed for use with this camcorder only. Use this cable when the Built-in USB Cable of the camcorder (p. 20) is too short for connection.

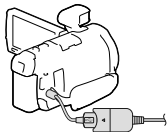

Lens hood (1)

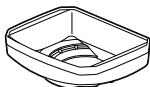

Step Down Ring (1)



Wireless Remote Commander (1)



Wind screen (1)



Rechargeable battery pack NP-FV50 (1)

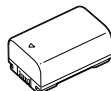

“Operating Guide” (This manual) (1)

Notes

- The “PlayMemories Home” software and “PlayMemories Home Help Guide” can be downloaded from the Sony website (p. 44).

Charging the battery pack

- 1 Turn off your camcorder by closing the LCD screen, and attach the battery pack (be sure to store the viewfinder first).

- Align the indentation on the camcorder and projection on the battery pack, then slide the battery pack upwards.

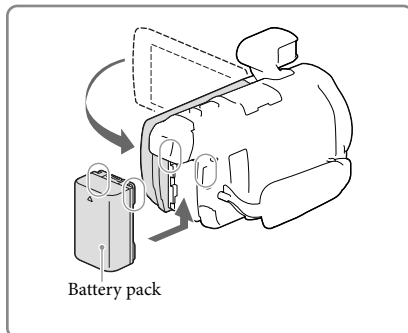

- 2 Connect the AC Adaptor (①) and the power cord (mains lead) (②) to your camcorder and the wall outlet (wall socket).

- The CHG (charge) lamp turns on.
- The CHG (charge) lamp turns off when the battery pack is fully charged. Disconnect the AC Adaptor from the DC IN jack of your camcorder.

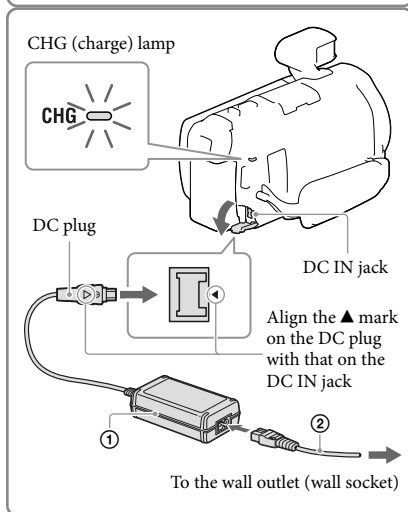

Notes

- You cannot attach any "InfoLITHIUM" battery pack other than the V series to your camcorder.
- When attaching a video light (sold separately), it is recommended that you use an NP-FV70 or NP-FV100 battery pack.
- You cannot use the NP-FV30 "InfoLITHIUM" battery pack with your camcorder.
- In the default setting, the power turns off automatically if you leave your camcorder without any operation for about 2 minutes, to save battery power ([Power Save], p. 54).

Charging the battery using your computer

Turn off your camcorder and connect the camcorder to a running computer using the Built-in USB Cable.

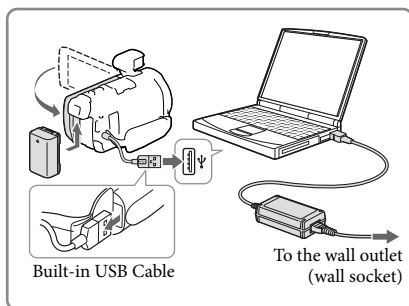

To charge the battery using an AC-UD10 USB charger/AC Adaptor (sold separately)

You can charge the battery by connecting the Built-in USB Cable to a wall outlet (wall socket) using an AC-UD10 USB charger/AC Adaptor (sold separately). You cannot use a Sony CP-AH2R, CP-AL, or AC-UP100 portable power supply device (sold separately) to charge the camcorder.

Charging time

Approximate time (min.) required to fully charge a fully discharged NP-FV50 battery pack (supplied).

When using the AC Adaptor: 155 min.

When using your computer connected with the Built-in USB Cable*: 280 min.

- The charging times shown above are measured when charging the camcorder at a room temperature of 25 °C (77 °F). It is recommended that you charge the battery in a temperature range of 10 °C to 30 °C (50 °F to 86 °F).

* The charging times are measured without using the USB connection support cable.

To remove the battery pack

Close the LCD screen. Slide the BATT (battery) release lever (①) and remove the battery pack (②).

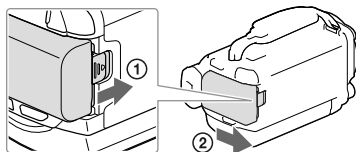

To use your camcorder continuously for a long time

Connect the AC adaptor and the power cord (mains lead) to your camcorder and the wall outlet (wall socket).

For details on how to connect the AC adaptor, refer to “Charging the battery pack” (p. 19).

By using the AC adaptor, you can use your camcorder without worrying about the battery running out of charge.

Notes on the AC Adaptor

- Do not short-circuit the DC plug of the AC Adaptor or battery terminal with any metallic objects. This may cause a malfunction.
 - Disconnect the AC Adaptor from the camcorder while holding both the camcorder and the DC plug.
- 
- Recording time, Playing time (p. 58)
 - Remaining battery indicator (p. 29)

Charging the battery pack abroad

You can charge the battery pack in any countries/regions using the AC Adaptor supplied with your camcorder within the AC 100 V - 240 V, 50 Hz/60 Hz range. Do not use an electronic voltage transformer.

Turning the power on, and setting the date and time

For information on your camcorder model, see the following page:

Functions and equipment → p.11

- 1 Open the LCD screen of your camcorder and turn the power on.

- You can also turn on the camcorder by pressing POWER (p. 15).

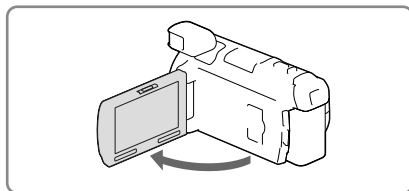

- 2 Select the desired language, then select [Next].

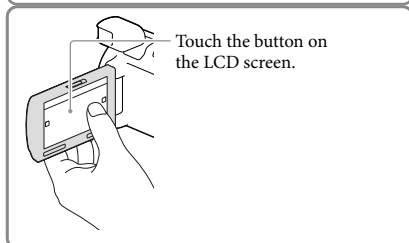

- 3 Select the desired geographical area with [Left] / [Right], then select [Next].

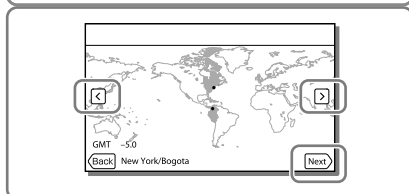

- 4 Set [Daylight Savings] or [Summer Time], select the date format and the date and time.

- If you set [Daylight Savings] or [Summer Time] to [On], the clock advances 1 hour.
- When you select the date and time, select one of the items and adjust the value with [Up] / [Down].
- When you select [OK] → [X], the date and time setting operation is complete.

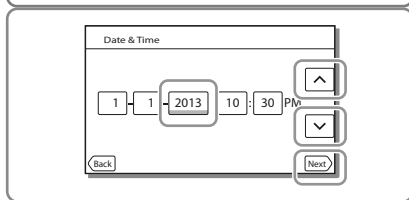

Changing the language setting

You can change the on-screen displays to show messages in a specified language.

Select [MENU] → [Setup] → [General Settings] → [Language Setting] → a desired language.

To turn off the power

Close the LCD screen or press the POWER button (p. 15).

If the viewfinder is pulled out, retract the viewfinder as shown in the illustration on the right.

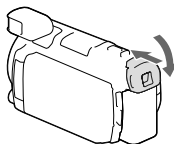

On turning the camcorder on or off using the LCD screen or the viewfinder

The power of the camcorder is turned on or off depending on the status of the LCD screen or the viewfinder.

Status		Power of the camcorder
LCD screen	Viewfinder	
Open	Retracted	On
	Pulled out	On
Closed	Retracted	Off
	Pulled out	On

Notes

- Even if the LCD screen is closed, if the viewfinder is pulled out, the camcorder is not turned off. When you turn off the power of the camcorder, make sure that the viewfinder is retracted to the original position.

When you make recording with the viewfinder only

Pull out the viewfinder (①) and close the LCD panel and then adjust the angle you want (②). If the indicator on the viewfinder appears blurred, adjust the appearance using the viewfinder lens adjustment lever located on the above of the viewfinder.

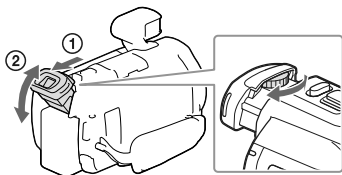

To adjust the angle of the LCD panel

First open the LCD panel 90 degrees to the camcorder (①), and then adjust the angle (②).

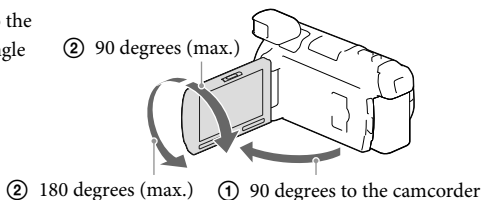

To turn off the beep sound

Select [MENU] → [Setup] → [🔧 General Settings] → [Beep] → [Off].

Notes



- The recording date and time are recorded automatically on the recording media. They are not displayed during recording. However, you can check them as [Data Code] during playback. To display them, select [MENU] → [Setup] → [▶ Playback Settings] → [Data Code] → [Date/Time].
- Once the clock is set, the clock time is automatically adjusted with [Auto Clock ADJ] and [Auto Area ADJ] set to [On]. The clock may not automatically adjust to the correct time, depending on the country/region selected for your camcorder. In this case, set [Auto Clock ADJ] and [Auto Area ADJ] to [Off] (models with GPS).



- To set the date and time again: [Date & Time Setting] (p. 54)
- To calibrate the touch panel: [Calibration] (p. 54)

Preparing the recording media

The recording media that can be used are displayed on the screen of your camcorder as following icons.

Default recording medium	Alternative recording medium
 Internal memory	 Memory card

Notes

- You cannot select a different recording medium for movies and for photos.

Selecting a recording medium

Select **[MENU]** → **[Setup]** → **[Media Settings]** → **[Media Select]** → the desired medium.

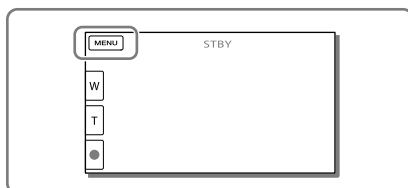

Inserting a memory card

Open the cover, and insert the memory card until it clicks.

- The [Preparing image database file. Please wait.] screen appears if you insert a new memory card. Wait until the screen disappears.

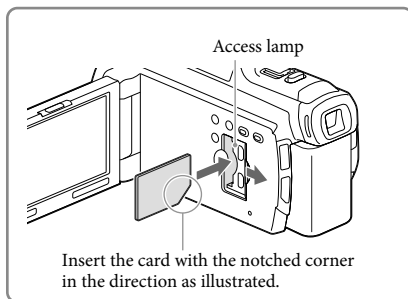

To eject the memory card

Open the cover and lightly push the memory card in once.

Notes

- To ensure stable operation of the memory card, it is recommended to format the memory card with your camcorder before the first use (p. 53). Formatting the memory card will erase all the data stored on it and the data will be irrecoverable. Save your important data on your PC, etc.
- If [Failed to create a new Image Database File. It may be possible that there is not enough free space.] is displayed, format the memory card (p. 53).
- Confirm the direction of the memory card. If you forcibly insert the memory card in the wrong direction, the memory card, memory card slot, or image data may be damaged.
- When inserting or ejecting the memory card, be careful so that the memory card does not pop out and drop.

Types of memory card you can use with your camcorder

	SD Speed Class	Capacity (operation verified)	Described in this manual
“Memory Stick PRO Duo” media (Mark2)			
“Memory Stick PRO-HG Duo” media	—	Up to 32 GB	“Memory Stick PRO Duo” media
“Memory Stick XC-HG Duo” media		Up to 64 GB	
SD memory card			
SDHC memory card	Class 4 or faster	Up to 64 GB	SD card
SDXC memory card			

- Operation with all memory cards is not assured.

Notes

- A MultiMediaCard cannot be used with this camcorder.
- Movies recorded on the “Memory Stick XC-HG Duo” media and SDXC memory cards cannot be imported to or played back on computers or AV devices not supporting the exFAT* file system by connecting the camcorder to these devices with the USB cable. Confirm in advance that the connecting equipment is supporting the exFAT system. If you connect an equipment not supporting the exFAT system and the format screen appears, do not perform the format. All the data recorded will be lost.
* The exFAT is a file system that is used for the “Memory Stick XC-HG Duo” media and SDXC memory cards.



- Recording/playback/editing media: Screen indicators during recording (p. 72)
- Recording time of movies/number of recordable photos (p. 58)

Recording

For information on your camcorder model, see the following page:
 Functions and equipment → p.11

In the default setting, movies and photos are recorded on the internal memory. Movies are recorded with high definition image quality (HD).

Recording movies

1 Open the LCD screen.

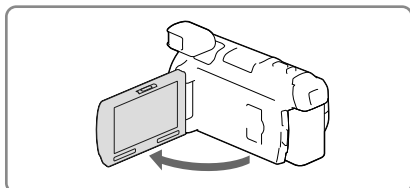

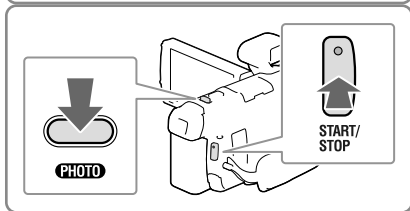

2 Press START/STOP to start recording.

- To stop recording, press START/STOP again.
- You can record photos during movie recording by pressing PHOTO (Dual Capture).



Notes

- If you close the LCD screen while recording movies, the camcorder stops recording (only when the viewfinder is retracted).
- The maximum continuous recordable time of movies is about 13 hours.
- When a movie file exceeds 2 GB, the next movie file is created automatically.
- The flash does not work while the  (movie) lamp is lit.
- The following states will be indicated if data is still being written onto the recording media after recording has finished. During this time, do not apply shock or vibration to the camcorder, or remove the battery or AC Adaptor.
 - Access lamp (p. 25) is lit or flashing
 - The media icon in the upper right of the LCD screen is flashing
- You may not be able to shoot photos depending on the setting in [ REC Mode] and [ Frame Rate].
- The LCD screen of your camcorder can display recording images across the entire screen (full pixel display). However, this may cause slight trimming of the top, bottom, right, and left edges of images when played back on a TV which is not compatible with full pixel display. It is recommended you record images with [Grid Line] set to [On] and using the outer frame of [Grid Line] (p. 52) as a guide.



- Recording time, recordable number of photos (p. 58)
- [Media Select] (p. 25)
- Recordable time, remaining capacity [Media Info] (p. 53)

Shooting photos

- 1 Open the LCD screen and press MODE to turn on the  (Photo) lamp.

- You can also switch the shooting mode by selecting [MODE] on the LCD screen.

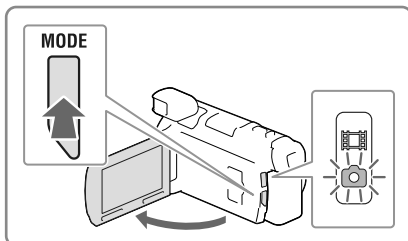

- 2 Press PHOTO lightly to adjust the focus, then press it fully.

- When the focus is adjusted properly, AE/AF lock indicator appears on the LCD screen.

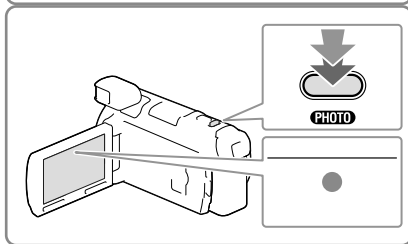

- [Flash] (p. 52)
- To change the image size:  Image Size] (p. 52)

To display items on the LCD screen

Items on the LCD screen disappear if you do not operate the camcorder for a few seconds after you turn the camcorder on or switch between the movie recording and photo shooting modes.

Touch anywhere except the buttons on the LCD screen to display information on icons with functions convenient for recording.



- To display items on the LCD screen all the time: [Display Setting] (p. 52)

Screen indicators during recording

Described here are icons for both movie recording and photo recording modes. Refer to the page in () for details.

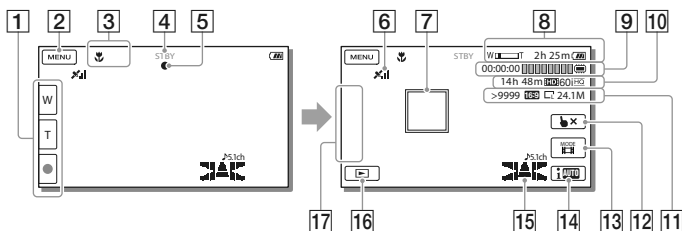

- 1** Zoom button (W: Wide/T: Telephoto), START/STOP button (in movie recording mode), PHOTO button (in photo recording mode)
- 2** MENU button (50)
- 3** Status detected by Intelligent Auto (35)
- 4** Recording status ([STBY]/[REC])
- 5** AE/AF (automatic exposure/automatic focus) lock (28)
- 6** GPS triangulating status* (37)
- 7** Tracking focus
- 8** Zoom, Remaining battery
- 9** Counter (hour: minute: second), Capturing a photo, Recording/playback/editing media (72)
- 10** Estimated recording remaining time, Recording image quality, Frame rate, Recording mode (HD/STD), Movie size (MP4) (34)
- 11** Approximate number of recordable photos, Aspect ratio (16:9 or 4:3), Photo size (L/M/S)
- 12** Tracking focus cancel button
- 13** [MODE] (Shooting Mode) button (28)
- 14** Intelligent Auto button (35)
- 15** Audio mode (52), Audio Level Display (52)
- 16** View Images button (31)
- 17** My Button (you can assign your favorite functions to icons displayed in this area) (52)

* Models with GPS

To record in mirror mode

Open the LCD panel 90 degrees to the camcorder (①), then rotate it 180 degrees to the lens side (②).

A mirror-image of the subject appears on the LCD screen, but the image will be normal when recorded.

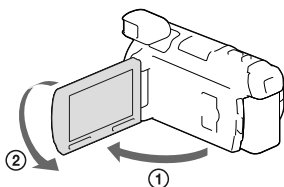

Zooming

Move the power zoom lever to magnify or reduce the size of the image.



W (Wide angle): Wider range of view

T (Telephoto): Close view

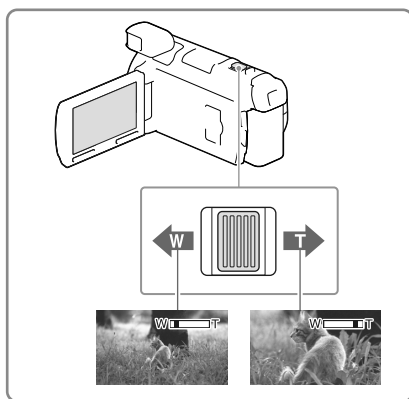
- You can magnify images up to 17 times (Extended Zoom) the original size with the power zoom lever.
- Move the power zoom lever slightly for a slower zoom. Move it further for a faster zoom.



Notes

- Be sure to keep your finger on the power zoom lever. If you move your finger off the power zoom lever, the operation sound of the power zoom lever may also be recorded.
- You cannot change the zoom speed with the  /  button on the LCD screen.
- The minimum possible distance between camcorder and subject while maintaining sharp focus is about 1 cm (about 13/32 in.) for wide angle and about 80 cm (about 31 1/2 in.) for telephoto.
- You can magnify images up to 10 times using optical zooming in the following cases:
 - When [SteadyShot] is set to other than [Active]
 - When the  (Photo) lamp is lit



- Further zooming: [Digital Zoom] (p. 51)

Playback

For information on your camcorder model, see the following page:



Functions and equipment → p.11

You can search for recorded images by date and time of recording (Event View) or location of recording (Map View (models with GPS)).

- 1 Open the LCD screen and press the  button on the camcorder to enter the playback mode.

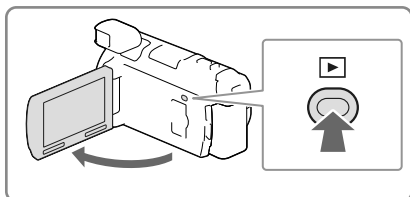
- You can enter the playback mode by selecting  on the LCD screen (p. 29).



- 2 Select  /  to move the desired event to the center (①) and then select it (②).

- The camcorder displays recorded images as an event automatically, based on the date and time.

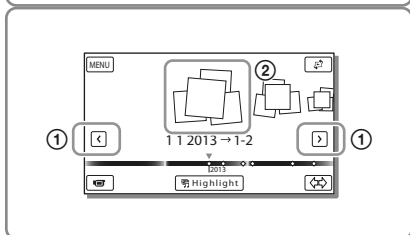





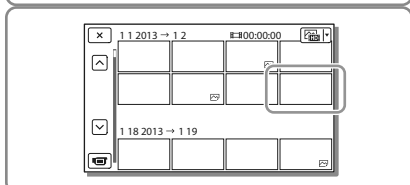

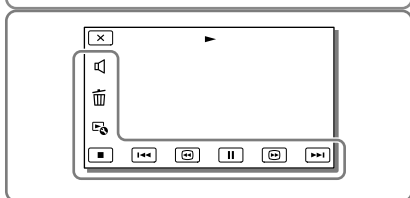

- 3 Select the image.

- The camcorder plays from the selected image to the last image in the event.







- 4 Select the appropriate buttons on the LCD screen for various playback operations.



	Volume		Previous/Next
	Delete		Fast-reverse/fast-forward
	Context		Play/Pause
	Stop		Play/stop slide show

- Some buttons described above may not appear, depending on the image being played back.

- As you repeat selecting  /  during playback, movies are played as fast as about 5 times → about 10 times → about 30 times → about 60 times.
- Select  /  during pause to play movies slowly.
- To repeat Slideshow, select  → [Slideshow Set].

Screen display on the Event View screen

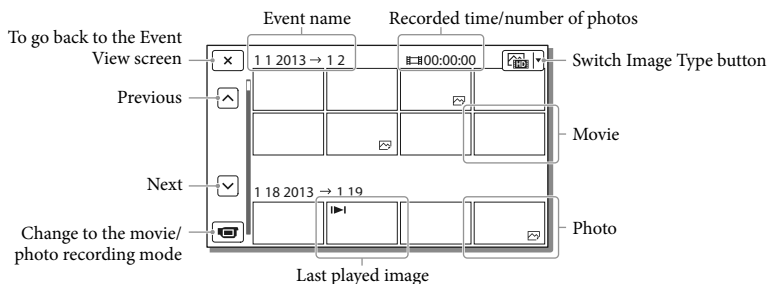
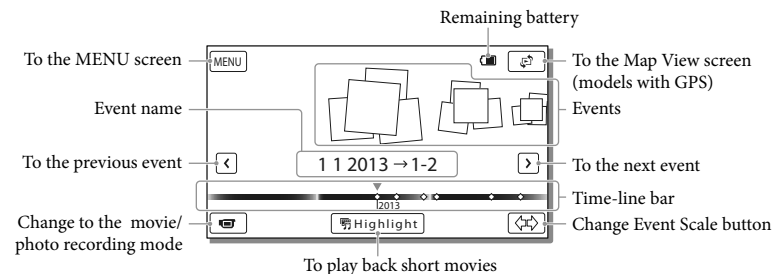

- Reduced-size images which enable you to view many images at the same time on an index screen are called “thumbnails.”

Notes

- To prevent your image data from being lost, save all your recorded images on external media periodically (p. 47).
- In the default setting, a protected demonstration movie is pre-recorded.

To play movies and photos from the Map View (Models with GPS)

Switch to the Map View by touching  → [Map View].

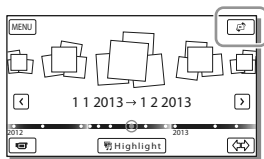

- When you use the map data for the first time:

A message appears asking you to confirm whether you agree with the terms of the license agreement of the map data. You can use the map data by touching [Yes] on the screen after agreeing to the terms of the license agreement (p. 68).

You cannot use the map data if you touch [No]. However, when you try to use the map data for the second time, the same message will appear on the screen, and you can use the map data by touching [Yes].

To play back images with other devices

- You may not be able to play back with other devices images that were recorded on your camcorder normally. Also, you may not be able to play back images recorded on other devices with your camcorder.
- Standard definition image quality (STD) movies recorded on SD memory cards cannot be played on AV equipment of other manufacturers.

Recording images with various settings

For information on your camcorder model, see the following page:

Functions and equipment → p.11

Selecting the image quality of movies (Recording mode)

You can switch the recording mode to select the movie quality when recording high definition image quality (HD) movies. The recording time (p. 58) or the type of media device to which the images can be copied may change, depending on the recording mode selected. ([Standard **HQ**] is the default setting.)

- 1 Select **MENU** → [Image Quality/Size] → [**REC Mode**].
- 2 Select the desired recording mode.

Recording mode and the media devices to which the images can be copied

Types of media	Recording mode		
	PS*	FX	FH/HQ/LP
On this camcorder			
Internal memory	✓	✓	✓
Memory card	✓	✓	✓
On external devices			
External media device	✓	✓	✓
Blu-ray discs	✓	✓	✓
AVCHD recording discs	—	—	✓

- * PS can be set only when the the [**Frame Rate**] is set to [60p] (models with the NTSC color system) / [50p] (models with the PAL color system).

Capturing smiles automatically (Smile Shutter)

A photo is recorded automatically when the camcorder detects the smile of a person during movie recording (p. 52). ([Dual Capture] is the default setting.)

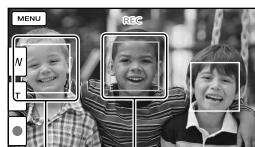

The camcorder is detecting a face.



The camcorder is detecting a smile (orange).

Notes

- When set to the following, you cannot use the Smile Shutter function.
 - [**REC Mode**]: [Highest Quality **FX**]
 - [**Frame Rate**]: [60p] (models with the NTSC color system) or [50p] (models with the PAL color system)
 - Smiles may not be detected depending on recording conditions, subject conditions, and the setting of your camcorder.
-  [Smile Sensitivity] (p. 52)

Selecting the suitable setting automatically for the recording situation (Intelligent Auto)

Your camcorder records movies after selecting the most suitable setting for the subjects or the situation automatically. ([On] is the default setting.)



- 1 Select  → [On] →  at the right bottom of the recording screen of movies or photos.











- 2 Point the camcorder toward the subject and start recording.

- The icons that correspond to the conditions detected are displayed.



Face detection:  (Portrait),  (Baby)



Scene detection:  (Backlight),  (Landscape),  (Night Scene),  (Spotlight),  (Low light),  (Macro)

Camera-shake detection:  (Walk),  (Tripod)

Sound detection:  (Auto Wind NR)

- To cancel the Intelligent Auto function, select  → [Off].

To record images brighter than those recorded using the Intelligent Auto function





Select  → [Camera/Mic] →  [Manual Settings] → [Low Lux].

Notes

- The camcorder may not detect the expected scene or subject, depending on the recording conditions.

Selecting the recording format of movies

Your camcorder can record movies with three different recording formats.

- 1 Select  → [Image Quality/Size] → [ **HD** /  **MP4** /  **STD** Setting].
- 2 Select the desired image setting.

HD Quality:

This format is a high definition digital video camera format. Enjoy beautiful images on a big screen.

MP4:

This format is easy for playing back your movies on a smartphone, for uploading to a network or for uploading to the Web.

STD Quality:

This format is a standard definition digital video camera format. This is useful for saving your movies to a DVD.

Using the manual adjustment features

It is convenient to make manual adjustments using the MANUAL dial, by assigning a menu item ([Focus] in the default setting) to the MANUAL dial.

MANUAL button

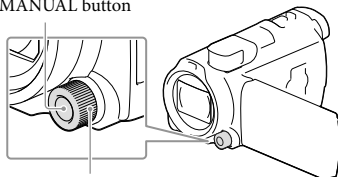

MANUAL dial

1 Press MANUAL to switch to manual operation mode.

- Pressing MANUAL switches the operation mode between manual and automatic.

2 Rotate the dial to make the adjustment.

Items you can control with the MANUAL dial

- [Focus] (p. 51)
- [Exposure] (p. 51)
- [IRIS] (p. 51)
- [Shutter Speed] (p. 51)
- [AE Shift] (p. 51)
- [White Balance Shift] (p. 51)

To assign the menu item to the MANUAL dial

- 1 Press and hold MANUAL down for a few seconds.
- 2 Rotate the MANUAL dial and select the item to be assigned.

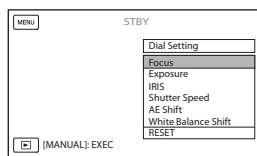

- Select [RESET] to reset the items adjusted manually to the default settings.

3 Press MANUAL.

- The camera data that appears on the LCD screen will differ, depending on the recording settings of the camcorder. The settings will be displayed with the following icons.
 - **AUTO**: Automatic
 - **MANUAL**: Exposure is set manually.
 - **AE/A**: IRIS priority
 - **AE/S**: Shutter speed priority



Notes

- Manual settings will be retained even if you change the assigned item of the MANUAL dial. However, if you set [Exposure] after setting [AE Shift] manually, [Exposure] will override [AE Shift].
 - If you set either one of [Exposure], [IRIS], or [Shutter Speed], the settings of other 2 items are canceled.
-  [Data Code] (p. 53)

Recording information on your location (Models with GPS)

For information on your camcorder model, see the following page:

Functions and equipment → p.11

When you set [GPS Setting] to [On] (the default setting), the GPS triangulating icon will appear on the screen and the camcorder will start searching for GPS satellite signals. The icon displayed will vary according to the intensity of the signal received. The GPS function is available when ,  or  are displayed.

The following features are available if you use the GPS (Global Positioning System) function.

- Recording location information on movies or photos ([On] is the default setting.)
- Playing movies and photos by searching for them from a map (Map View, p. 33)
- Displaying a map of your current location

If you do not want to record location information

Select [MENU] → [Setup] → [General Settings] → [GPS Setting] → [Off].

Notes

- It may take a while before the camcorder starts triangulating.
- Use the GPS function outdoors and in open areas, as the radio signals can best be received in such areas.
- The map always displays the north at the top.

Playing images on a TV

If you connect the camcorder to the HDMI input jack of a TV, the image quality viewed on the TV screen is high definition image quality (HD). And if you can connect the camcorder to the A/V input jack of a TV, the image quality viewed on the TV is standard definition image quality (STD).

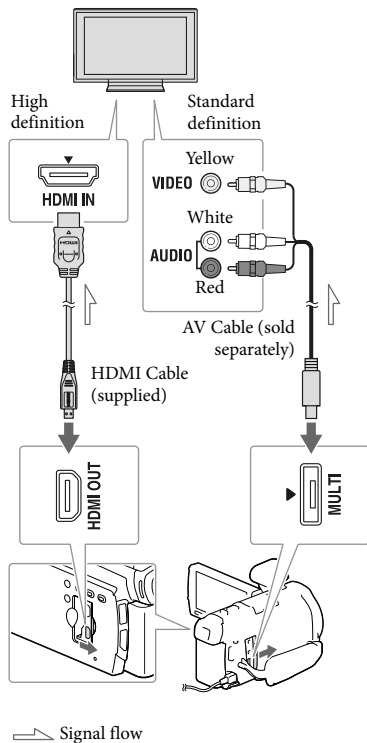

- 1 Switch the input on the TV to the connected jack.
- 2 Connect the camcorder to a TV.
- 3 Play a movie or a photo on the camcorder (p. 31).

Notes

- Refer to the instruction manuals of the TV as well.
- Use the supplied AC Adaptor as the power source (p. 19).
- If the TV does not have the HDMI input jack, use an AV Cable (sold separately) for connection.
- When movies are recorded with standard definition image quality (STD), they are played back in standard definition image quality (STD) even on a high definition TV.
- When you play back standard definition image quality (STD) movies on a 4:3 TV that is not compatible with the 16:9 signal, set [ Wide Mode] to [4:3] to record movies with 4:3 aspect ratio.
- If you connect your camcorder to the TV using more than one type of cable to output images, HDMI output takes priority.

Enjoying 5.1ch surround sound

In the default setting, you can record Dolby Digital 5.1ch surround sound with the built-in microphone. Realistic sound can be enjoyed when playing a movie on devices that support 5.1ch surround sound input.



When your TV is monaural (When your TV has only one audio input jack)

Connect the yellow plug of an AV Cable (sold separately) to the video input jack and connect the white (left channel) or red (right channel) plug to the audio input jack of your TV or VCR.

When connecting to your TV via a VCR

Connect your camcorder to the LINE IN input on the VCR using an AV Cable (sold separately). Set the input selector on the VCR to LINE (VIDEO 1, VIDEO 2, etc.).



- Setting the aspect ratio supported by the TV: [TV Type] (p. 53)

On "Photo TV HD"

This camcorder is compatible with the "Photo TV HD" standard. "Photo TV HD" allows for highly-detailed, photo-like depiction of subtle textures and colors. By connecting Sony's Photo TV HD-compatible devices using an HDMI cable*, a whole new world of photos can be enjoyed in breathtaking HD quality.

- * The TV will automatically switch to the appropriate mode when displaying photos.

Using the built-in projector

You can use a flat surface such as a wall as a screen to view recorded images using the built-in projector.

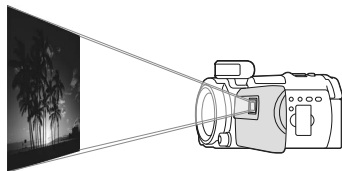

- 1 Face the projector lens towards a surface, such as a wall, and then press PROJECTOR.

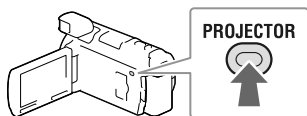

- 2 Select [Image Shot on This Device] on the LCD screen.
- 3 When the operating guide screen appears, select [Project].

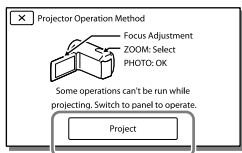

- This screen appears the first time you use the built-in projector after the camcorder is turned on.

- 4 Adjust the focus of the projected image using the PROJECTOR FOCUS lever.

PROJECTOR FOCUS lever

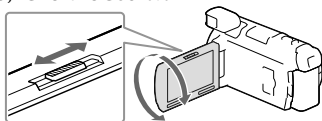

- The projected image is larger when the distance between your camcorder and the reflecting surface increase.
- It is recommended that you place the camcorder about 0.5 m (1.6 feet) or further away from the surface that the images are to be projected onto.

- 5 When playing back images, use the power zoom lever to move the selection frame that appears on the LCD screen, then press PHOTO button.

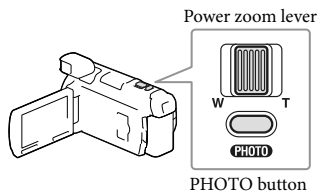

- For details on playback, see page 31.
- When you use the wireless remote commander, use ◀/▶/▲/▼ to move the selection frame and press ENTER to start playing the framed item.
- To turn off the projector, press PROJECTOR.

To use the projector for your computer or smartphone

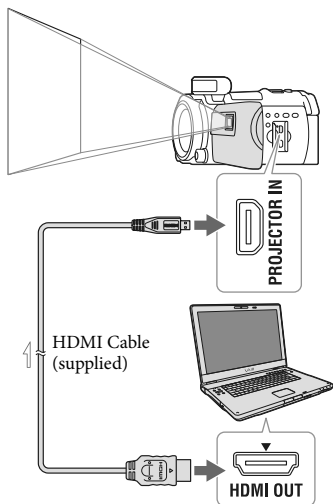

➤ Signal flow

- Connect the PROJECTOR IN jack of the camcorder to an HDMI output jack of the other device using the HDMI cable (supplied), then select [Image from External Device] in step 2.
- If the terminal of the device connected is not compatible with the HDMI cable (supplied), use an HDMI plug adaptor (sold separately).
- You can only operate the PROJECTOR FOCUS lever while projecting images.

Notes

- The LCD screen turns off while an image is being projected.
 - Be careful of the following operations or situations while using the projector.
 - Make sure not to project images towards the eyes.
 - Make sure not to touch the projector lens.
 - The LCD screen and the projector lens become hot while in use.
- Using the projector shortens battery life (using the supplied AC Adaptor is recommended).
 - The following operations are unavailable while you are using the projector.
 - Map operation (models with GPS)
 - Output of Highlight Playback to a device such as a TV
 - Operation of the camcorder with the LCD screen closed
 - Several other functions
 - When the projected images contain a lot of black, faint color unevenness may appear. This is caused by light reflection in the projector lens and is not a malfunction.

Editing on your camcorder

For information on your camcorder model, see the following page:

Functions and equipment → p.11

Notes

- Some basic editing operations can be done on the camcorder. If you want to perform advanced editing operations, install the “PlayMemories Home” software.
- You cannot restore images once they are deleted. Save important movies and photos in advance.
- Do not remove the battery pack or the AC Adaptor from your camcorder while deleting or dividing the images. It may damage the recording media.
- Do not eject the memory card while deleting or dividing images from the memory card.
- If you delete or divide movies/photos that are included in saved scenarios, the scenarios will also be deleted.

Deleting movies and photos

- 1 Select **[MENU]** → **[Edit/Copy]** → **[Delete]**.
- 2 Select **[Multiple Images]**, and then select the type of image you want to delete.

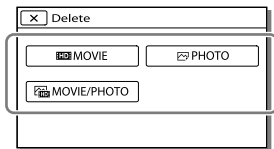

- 3 Add check marks ✓ to the movies or photos to be deleted and select **[OK]**.

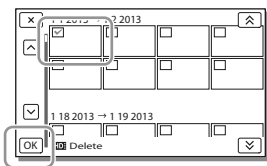

To delete all movies/photos in the selected date all together

- 1 In step 2, select **[All In Event]**.
- 2 Select the date you want to delete using **[<] / [>]**, and then select **[OK]**.

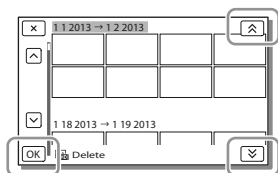

To delete a part of a movie

You can divide a movie and delete it.





- Release protection: **[Protect]** (p. 53)
- **[Format]** (p. 53)

Dividing a movie

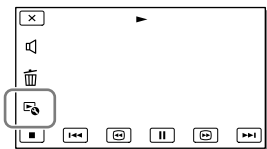
- 1 Select **[Divide]** → **[Divide]** on the movie playback screen.



- Select the point where you want to divide the movie into scenes using  / , and then select .

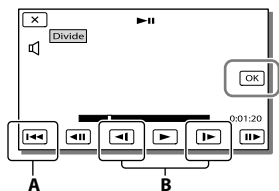

- A:** Returns to the beginning of the selected movie
B: Adjusts the capturing point with more precision

Notes



- The point where you touch  and the actual dividing point may differ as your camcorder selects the dividing point in increments of about half a second.
- An MP4 movie cannot be divided.

Capturing a photo from a movie

You can capture images from movies recorded with your camcorder.

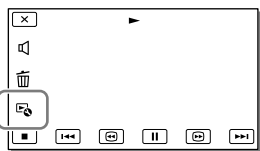
- Select  → [Photo Capture] that appears on the playback screen of a movie.



- Select the point where you want to capture a photo using  / , and then select .

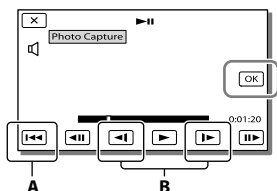

- A:** Returns to the beginning of the selected movie
B: Adjusts the capturing point with more precision

If the movie was recorded with one of the following image quality levels, the image size will be set as shown below.

- High definition image quality (HD) or MP4: 2.1 M (16:9)
- Wide aspect ratio (16:9) with standard definition image quality (STD): 0.2 M (16:9)
- 4:3 aspect ratio with standard definition image quality (STD): 0.3 M (4:3)

Notes

- You cannot save captured images to the memory card (models without a USB input function).

On recording date and time of captured photos

- The recording date and time of captured photos are the same as the recording date and time of the movies.
- If the movie you are capturing from has no data code, the recording date and time of the photo will be the date and time you captured from the movie.

Playing images on a computer

The “PlayMemories Home” software allows you to import movies and still images to your computer to use them in a variety of ways.

What you can do with “PlayMemories Home” software (Windows)

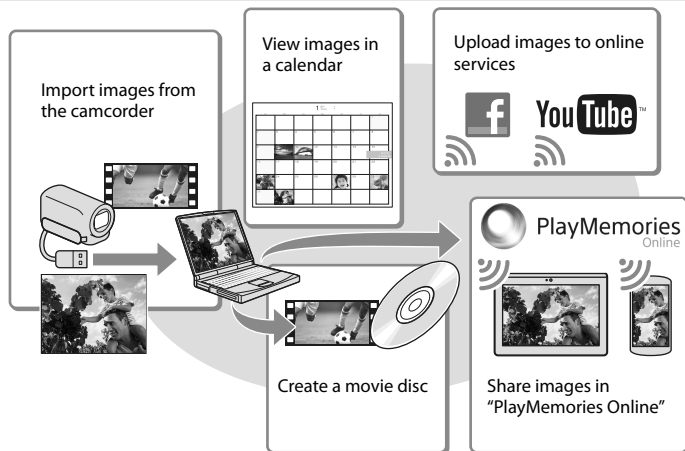

“PlayMemories Home” can be downloaded from the following URL.

www.sony.net/pm

Notes

- An Internet connection is required to install “PlayMemories Home.”
- An Internet connection is required to use “PlayMemories Online” and other online services. The services may not be available in some countries/regions.

Software for Mac

The “PlayMemories Home” software is not supported with Mac computers. To import images from the camcorder to your Mac and play them, use the appropriate software on your Mac.

For details, visit the following URL.

<http://www.sony.co.jp/imsoft/Mac/>

Preparing a computer (Windows)

For information on your camcorder model, see the following page:

Functions and equipment → p.11

Checking the computer system

OS*1
Microsoft Windows XP SP3*2/Windows Vista SP2*3/Windows 7 SP1/Windows 8
CPU*4
Intel Core Duo 1.66 GHz or faster, or Intel Core 2 Duo 1.66 GHz or faster (Intel Core 2 Duo 2.26 GHz or faster is required when processing FX or FH movies, and Intel Core 2 Duo 2.40 GHz or faster is required when processing PS movies.)
Memory
Windows XP: 512 MB or more (1 GB or more is recommended) Windows Vista/ Windows 7/Windows 8: 1 GB or more
Hard disk
Disk volume required for installation: Approximately 500 MB
Display
Minimum 1,024 × 768 dots

*1 Standard installation is required. Operation is not assured if the OS has been upgraded or in a multi-boot environment.

*2 64-bit editions and Starter (Edition) are not supported. Windows Image Mastering API (IMAPI) Ver.2.0 or newer is required to use disc creation function, etc.

*3 Starter (Edition) is not supported.

*4 Faster processor is recommended.

Notes

- Operation with all computer environments is not assured.

Installing the “PlayMemories Home” software in your computer

- 1 Access the following download site using an Internet browser on your computer, then click [Install] → [Run].

www.sony.net/pm

- 2 Install according to the on-screen instructions.

- When the on-screen instructions prompting you to connect the camcorder to a computer appear, connect the camcorder to your computer with the Built-in USB Cable.

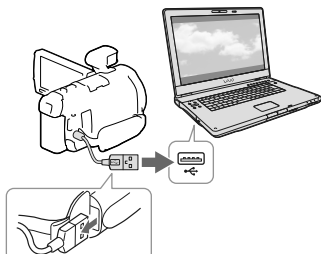

Built-in USB Cable

- When the installation completes, “PlayMemories Home” starts up.

Notes on installation



- If the “PlayMemories Home” software is already installed on your computer, connect the camcorder to your computer. Functions that can be used with this camcorder will then be available.
- If the “PMB (Picture Motion Browser)” software is installed on your computer, it will be overwritten by the “PlayMemories Home” software. In this case, you cannot use some

functions that were available with “PMB” with this “PlayMemories Home” software.



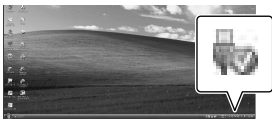

To disconnect your camcorder from the computer

- 1 Click the  icon at the bottom right of the desktop of the computer → [Safely remove USB Mass Storage Device].



- 2 Select  → [Yes] on the camcorder screen.
 - 3 Disconnect the USB cable.
- If you are using Windows 7 or Windows 8, click , then click .

Notes

- When you access the camcorder from the computer, use the “PlayMemories Home” software. Operation is not guaranteed if you operate the data using software other than the “PlayMemories Home” software or you directly manipulate files and the folders from a computer.
- Images cannot be saved to some discs depending on the configuration selected in [ REC Mode]. Movies recorded in [60p Quality ] (models with the NTSC color system)/[50p Quality ] (models with the PAL color system) or [Highest Quality ] mode can only be saved to a Blu-ray disc.
- You cannot create a disc with movies recorded in [ MP4] mode.
- The camcorder automatically divides an image file that exceeds 2 GB and saves the parts as separate files. All image files may be shown as separate files on a computer, however, the files will be handled properly by the import function and the playback function of the camcorder or the “PlayMemories Home” software.

Starting the “PlayMemories Home” software

- 1 Double-click the “PlayMemories Home” icon on the computer screen.

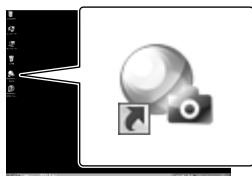

- When using Windows 8, select the “PlayMemories Home” icon from the start screen.

- 2 Double-click the “PlayMemories Home Help Guide” short-cut icon on the computer screen to see how to use “PlayMemories Home.”



- When using Windows 8, select [PlayMemories Home Help Guide] from the help menu of “PlayMemories Home.”
- If the icon is not displayed on the computer screen, click [Start] → [All Programs] → [PlayMemories Home] → the desired item.
- For details on “PlayMemories Home,” select  (“PlayMemories Home Help Guide”) on the software or visit the PlayMemories Home support page (<http://www.sony.co.jp/pmh-se/>).

Creating a standard definition image quality (STD) disc with a recorder

Connect your camcorder to a disc recorder with an AV Cable (sold separately). You can copy images played back on your camcorder on a disc or video cassette.

Notes

- Connect your camcorder to the wall outlet (wall socket) using the supplied AC Adaptor for this operation (p. 19).
- Refer to the instruction manual supplied with the device connected.

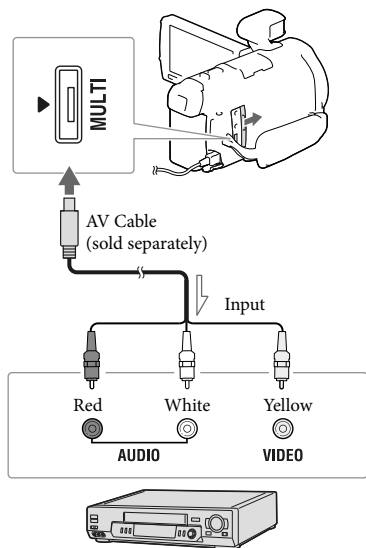

— Signal flow

1 Insert the recording medium in the recording device (a disc recorder, etc.).

- If your recording device has an input selector, set it to the input mode.

2 Connect your camcorder to the recording device with an AV Cable (sold separately).

- Connect your camcorder to the input jacks of the recording device.

3 Start playback on your camcorder, and record it on the recording device.

4 When dubbing is finished, stop the recording device, and then your camcorder.

Notes

- You cannot copy images to recorders connected with an HDMI cable.
 - Since copying is performed via analog data transfer, the image quality may deteriorate.
 - High definition image quality (HD) movies will be copied with standard definition image quality (STD).
 - When you connect a monaural device, connect the yellow plug of an AV Cable (sold separately) to the video input jack, and the white (left channel) or the red (right channel) plug to the audio input jack on the device.
- Ⓜ
- Copying date and time information: [Data Code] (p. 53)
 - Using 4:3 screen size display device: [TV Type] (p. 53)

Saving images on an external media device with high definition (HD) image quality

You can save movies and photos on an external media device (USB storage devices), such as an external hard disk drive. The following functions will be available after you have saved your images on an external media device.

- You can connect your camcorder and the external media device, and then play back images stored on the external media device (p. 48).
- You can connect your computer and the external media device and import images to your computer using the “PlayMemories Home” software (p. 45).

Notes

- For this operation, you need the USB Adaptor Cable VMC-UAM2 (sold separately).
- Connect the AC Adaptor and the power cord (mains lead) to the DC IN jack of your camcorder and the wall outlet (wall socket).
- Refer to the instruction manual supplied with the external media device.

- 1 Connect your camcorder and the external media device using the USB Adaptor Cable (sold separately).

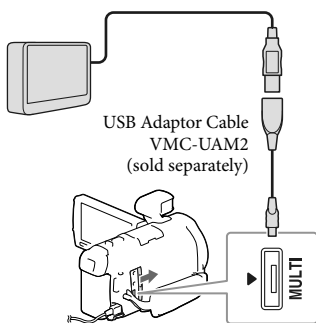

- Make sure not to disconnect the USB cable while [Preparing image database file. Please wait.] is displayed on the LCD screen.
- If [Repair Img. DB F.] is displayed on the camcorder screen, select .

- 2 Select [Copy.] on the camcorder screen.

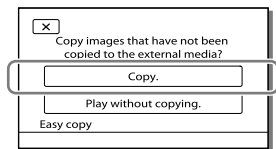

- Movies and photos that are stored on the recording media, and that have not yet been saved on to external media device can be saved on the connected media device at this time.
- This operation is available only when there are newly recorded images in your camcorder.
- To disconnect the external media device, select while the camcorder is in the playback standby mode (either Event View or Event Index is displayed).

To play back images in the external media device on the camcorder

Select [Play without copying.] in step 2 and select the image you want to view.

- You can also view images on a TV connected to your camcorder (p. 37).
- When an external media device is connected,  will appear on the Event View screen.

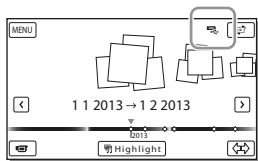

To delete images in the external media device

- 1 Select [Play without copying.] in step 2.
- 2 Select [MENU] → [Edit/Copy] → [Delete], and then follow the instructions that appear on the LCD screen to delete images.

To save the desired images in the camcorder to the external media device

- 1 Select [Play without copying.] in step 2.
 - 2 Select [MENU] → [Edit/Copy] → [Copy], and then follow the instructions that appear on the LCD screen to save images.
- If you want to copy images that have not yet been copied, select [MENU] → [Edit/Copy] → [Direct Copy] while your camcorder is connected to the external media device.

To play back high definition image quality (HD) movies on your computer

On the “PlayMemories Home” software (p. 45), select the drive that represents the external media device connected, and then play movies.

Notes

- The following devices cannot be used as an external media device:
 - media devices with a capacity exceeding 2 TB
 - ordinary disc drive such as CD or DVD drive
 - media devices connected via a USB hub
 - media devices with built-in USB hub
 - card reader
- You may not be able to use external media devices with a code function.
- The FAT file system is available for your camcorder. If the storage medium of the external device was formatted for the NTFS file system, etc., format the external media device using the camcorder before use. The format screen appears when an external media device is connected to your camcorder. Before formatting, make sure that you have no important data saved on the external media device as formatting will delete the data.
- Operation is not guaranteed with all devices satisfying the operating requirements.
- For details on available external media devices, go to the Sony support website in your country/region.
- The number of scenes you can save on the external media device is as follows. However, even if the external media device has free space, you cannot save scenes exceeding the following number.
 - High definition image quality (HD) movies: Max. 3,999
 - Standard definition image quality (STD) movies: Max. 9,999
 - MP4 movies and photos: Max. 40,000 (both MP4 movies and photos)

- If your camcorder does not recognize the external media device, try the following operations.
 - Reconnect the USB Adaptor Cable to your camcorder.
 - If the external media device has the AC power cord (mains lead), connect it to the wall outlet (wall socket).
- The number of scenes may be smaller depending on the type of images recorded.
- You cannot copy images from an external media device to the internal memory on the camcorder.

Using menus

The camcorder has various menu items under each of 6 menu categories.

 **Shooting Mode**

 **Camera/Mic**

 **Image Quality/Size**

 **Playback Function**

 **Edit/Copy**

 **Setup**

1 Select **MENU**.



2 Select a category.

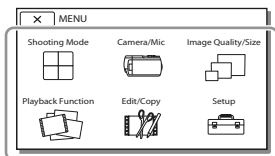

3 Select your desired menu item.

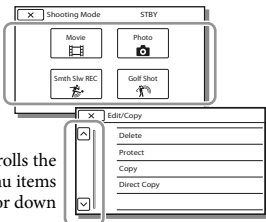

Scrolls the menu items up or down

Notes

- Select **X** to finish setting the menu or to return to the previous menu screen.

To find a menu item quickly

The [Camera/Mic] and [Setup] menus have sub-categories. Select the sub-category icon so that the LCD screen displays the list of menus in the sub-category selected.

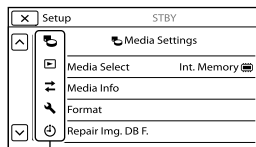

Sub-category icons

When you cannot select a menu item

Grayed out menu items or settings are not available.

When you select the grayed out menu item, your camcorder displays the reason why you cannot select the menu item or the instruction of under which condition you can set the menu item.

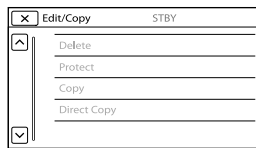







Menu lists

Shooting Mode





- Movie Records movies.
- Photo..... Shoots photos.
- Smth Slw REC Records smooth slow-motion movies.
- Golf Shot..... Divides two seconds of fast movement into frames which are then recorded as a movie and photos. Keep the subject in the white frame in the center of the screen when recording.

Camera/Mic

Manual Settings

- White Balance..... Adjusts the color balance to the recording environment.
- Spot Meter/Fcs..... Adjusts the brightness and focus for the selected subject simultaneously.
- Spot Meter..... Adjusts the brightness of images to a subject you touch on the screen.
- Spot Focus..... Adjusts the focus on a subject you touch on the screen.
- Exposure..... Adjusts the brightness of movies and photos. If you select [Manual], adjust the brightness (exposure) using  / .
- Focus..... Adjusts the focus manually. If you select [Manual], select  to adjust the focus for a nearby subject and  to adjust the focus for a distant subject.
- IRIS..... Sharpens the subject with its background blurred or sharpens the whole image.
- Shutter Speed..... Adjusts Shutter Speed. When you shoot a moving subject at a higher shutter speed, it appears as if frozen on the image. At a lower shutter speed, the subject appears as if it is flowing.
- AGC Limit..... Sets the maximum level of AGC (Auto Gain Control).
- AE Shift..... Adjusts the exposure. Touch  if the subject is white or the backlight is bright, or touch  if the subject is black or the light is dim.
- White Balance Shift Adjusts the white balance.
- Low Lux..... Records bright color images in the dim.

Camera Settings

- Scene Selection Selects an appropriate recording setting according to the type of scene, such as night view or beach.
-  Cinematone..... Adjusts the color of the movie to resemble the atmosphere of films when recording.
-  Fader..... Fades scenes in or out.
-  Self-Timer..... Sets the self-timer when your camcorder is in photo recording mode.
- Tele Macro..... Focuses on the subject with its background blurred.
-  SteadyShot Sets the SteadyShot function when recording movies.
-  SteadyShot..... Sets the SteadyShot function when shooting photos.
- Digital Zoom..... Sets the maximum zoom level of the digital zoom.
- Conversion Lens..... Sets the type of an attached conversion lens (sold separately).
- Auto Back Light..... Adjusts the exposure for backlit subjects automatically.
- Dial Setting..... Assigns a function to the MANUAL dial.
- NIGHTSHOT Light..... Emits infrared light when using NightShot.



- Face Detection Automatically detects faces.
- Smile Shutter Automatically takes a shot whenever a smile is detected.
- Smile Sensitivity Sets the smile detection sensitivity for the Smile Shutter function.



- Flash Sets how the flash is activated when shooting photos.
- Flash Level Sets the brightness of flash.
- Red Eye Reduction Prevents reddy when shooting with flash.



- Closer Voice Detects human faces and records the associated voice clearly.
- Blt-in Zoom Mic Records movies with vivid sound appropriate to the zoom position.
- Auto Wind NR Recognizes the recording conditions and reduces the wind noise.
- Audio Mode Sets the recording sound format (5.1ch surround/2ch stereo).
- Audio Rec Level Adjusts the audio recording level.



- My Button Assigns functions to My Buttons.
- Expanded Focus Magnifies the image that appears at the center of the screen by about 2.0 times.
- Grid Line Displays grid lines as a guide to make sure the subject is horizontal or vertical.
- Display Setting Sets the duration that icons or indicators are displayed on the LCD screen.
- Zebra Displays a zebra pattern as a guide for adjusting brightness.
- Peaking Displays an image on the screen with its outlines enhanced.
- Light Bright Adjusts the brightness of the video light.
- Audio Level Display Displays the audio level meter on the LCD screen while recording.

Image Quality/Size

- REC Mode Sets the mode to record movies.
- Frame Rate Sets the frame rate to record movies.
- HDMI** / **MP4** / **STD** Setting Sets the image quality for recording movies.
- Wide Mode Sets the horizontal to vertical ratio when recording movies with standard definition image quality (STD).
- x.v.Color Records a wider range of colors. Set this item when you watch images with a TV which is compliant with x.v.Color.
- Image Size Sets the photo size.

Playback Function

- Event View Starts playing images from the Event View display.
- Map View*1 Starts playing the images from the Map View display.
- Highlight Movie Starts playing Highlight Playback scenes or Highlight Scenarios saved with standard definition image quality (STD).
- Scenario Starts playing the scenarios that were saved by Highlight Playback.

Edit/Copy

- Delete.....Deletes movies or photos.
- Protect.....Protects movies or photos to avoid deleting.
- Copy.....Copies images.
- Direct Copy.....Copies images stored in the camcorder to some type of external media device.

Setup

Media Settings

- Media Select.....Selects the type of recording media (p. 25).
- Media Info.....Displays information on the recording media.
- Format.....Deletes and formats all data on the recording media.
- Repair Img. DB F.....Repairs the image database file on the recording media (p. 57).
- File Number.....Sets how to assign the file number to photos.

Playback Settings

- Data Code.....Displays information that was recorded automatically at the time of recording.
- Volume.....Adjusts the volume of playback sound (p. 31).
- Download Music*².....Downloads your favorite music files from the computer to your camcorder (while the camcorder is connected to the computer) that can be played with the Highlight Playback scenes.
- Empty Music*².....Deletes all music files.

Connection

- TV Type.....Converts the signal depending on the TV connected (p. 37).
- HDMI Resolution.....Selects the output image resolution when connecting your camcorder to a TV with the HDMI cable.
- CTRL FOR HDMI.....Sets whether or not the TV's Remote Commander is to be used when the camcorder is connected to a "BRAVIA" Sync compatible TV with the HDMI cable.
- USB Connect.....Select this item when no instructions appear on the LCD screen when you connect your camcorder to an external device via USB.
- USB Connect Setting...Sets the connection mode when the camcorder is connected to a computer or a USB device.
- USB LUN Setting.....Sets the camcorder to improve the compatibility of a USB connection by restricting some USB functions.

General Settings

- Beep.....Sets whether the camcorder sounds operation beeps or not.
- LCD Brightness.....Adjusts the brightness of the LCD screen.
- Your Location*¹.....Displays the current location on a map.
- Airplane Mode*¹.....Setting to be used when you are on board an airplane.
- GPS Setting*¹.....Receives the GPS signal.
- REC Lamp.....Turns the recording lamp on the front of the camcorder off.
- Remote Ctrl.....Sets the Wireless Remote Commander to be used.
- Language Setting.....Sets the display language (p. 22).
- 24p Mode*³.....Records 24p frame rate movies.

- Calibration Calibrates the touch panel.
- Battery Info Displays the approximate remaining battery time.
- Power Save Sets the LCD screen and the power so that they turn off automatically.
- Initialize Initializes all the settings to the default settings.
- Demo Mode Sets playback of the demonstration movie about the functions of the camcorder.

Clock Settings

- Date & Time Setting Sets the date and time.
- Area Setting Adjusts for a time difference without stopping the clock (p. 22).
- Auto Clock ADJ *¹ Adjusts the clock automatically by acquiring the time from the GPS system.
- Auto Area ADJ*¹ Corrects time differences automatically by acquiring the current location information from the GPS system.

*¹ HDR-PJ780VE/PJ790V/PJ790VE

*² HDR-PJ790/PJ790V

*³ HDR-PJ780E/PJ780VE/PJ790E/PJ790VE

Troubleshooting

For information on your camcorder model, see the following page:

Functions and equipment → p.11

If you run into any problems using your camcorder, follow the steps below.

- ① Check the list (p. 55 to 57), and inspect your camcorder.

- ② Disconnect the power source, attach the power source again after about 1 minute, and turn the camcorder on.

- ③ Press RESET (p. 15) using a pointed object, and turn the camcorder on. If you press RESET, all settings, including the clock setting, are reset.

- ④ Contact your Sony dealer or local authorized Sony service facility.

- You may need to initialize or change the current internal memory of your camcorder depending on the problem. If you do so, the data stored on the internal memory will be deleted. Be sure to save the data on the internal memory on other media (backup) before sending your camcorder for repair. We will not compensate you for any loss of internal memory data.
- During repair, we may check a minimum amount of data stored on the internal memory in order to investigate the problem. However, your Sony dealer will neither copy nor retain your data.
- See the "Handycam" User Guide (p. 10) for details on the symptoms of your camcorder, and "PlayMemories Home Help Guide" (p. 45) on connecting your camcorder to a computer.

The power does not turn on.

- Attach a charged battery pack to the camcorder (p. 19).
- The plug of the AC Adaptor has been disconnected from the wall outlet (wall socket). Connect it to the wall outlet (wall socket) (p. 19).

The camcorder does not operate even when the power is set to on.

- It takes a few seconds for your camcorder to be ready to shoot after the power is turned on. This is not a malfunction.
- Disconnect the AC Adaptor from the wall outlet (wall socket) or remove the battery pack, then reconnect it after about 1 minute. If the functions still do not work, press RESET using a pointed object. (If you press RESET (p. 15), all settings, including the clock setting, are reset.)

Your camcorder gets warm.

- Your camcorder may become warm during operation. This is not a malfunction.

The power abruptly turns off.

- Use the AC Adaptor (p. 19).
- In the default setting, the camcorder turns itself off when no operations are performed for about 2 minutes ([Power Save]) (p. 54), or turn on the power again.
- Charge the battery pack (p. 19).

Pressing START/STOP or PHOTO does not record images.

- The playback screen is displayed. Stop playback, and select [MENU] → [Shooting Mode] → [Movie] or [Photo].
- Your camcorder is recording the image you have just shot on the recording media. You cannot make new recording during this period.
- The recording media is full. Delete unnecessary images (p. 41).

- Total number of movie scenes or photos exceeds the recordable capacity of your camcorder (p. 58, 60). Delete unnecessary images (p. 41).

“PlayMemories Home” cannot be installed.

- An Internet connection is required to install “PlayMemories Home.”
- Check the computer environment or installation procedure required to install “PlayMemories Home.”

“PlayMemories Home” does not work correctly.

- Quit “PlayMemories Home” and restart your computer.

The camcorder is not recognized by the computer.

- Disconnect all USB devices from the USB jack of your computer except the keyboard, mouse, and your camcorder.
- Disconnect the Built-in USB Cable from the computer and restart the computer, then connect the computer and your camcorder again in the correct order.
- When both the Built-in USB Cable and the USB jack of the camcorder are connected to the external devices at the same time, disconnect the one that is not connected to a computer.

Self-diagnosis display/Warning indicators

For information on your camcorder model, see the following page:

Functions and equipment → p.11

If indicators appear on the LCD screen or viewfinder, check the following.

If the problem persists even after you have tried to fix a couple of times, contact your Sony dealer or local authorized Sony service facility. In this case, when you contact them, give them all the numbers of the error code beginning with C or E. You may hear a melody when some warning indicators appear on the screen.

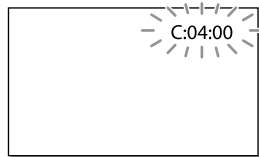

C:04:□□

- The battery pack is not an “InfoLITHIUM” battery pack (V series). Use an “InfoLITHIUM” battery pack (V series) (p. 19).
- Connect the DC plug of the AC Adaptor to the DC IN jack of your camcorder securely (p. 19).

C:06:□□

- The battery pack temperature is high. Change the battery pack or place it in a cool place.

C:13:□□ / C:32:□□

- Remove the power source. Reconnect it and operate your camcorder again.

E:□□:□□

- Follow the steps from ② on page 55.



- The battery pack is nearly used up.
-



- The battery pack temperature is high. Change the battery pack or place it in a cool place.
-



- No memory card is inserted (p. 25).
 - When the indicator flashes, there are not enough free spaces for recording images. Delete unnecessary images (p. 41), or format the memory card after storing the images on other media (p. 53).
 - The image data base file may be damaged. Check the data base file by selecting [MENU] → [Setup] → [Media Settings] → [Repair Img. DB F.] → the recording medium.
-



- The memory card is damaged.
 - Format the memory card with your camcorder (p. 53).
-



- Incompatible memory card is inserted (p. 26).
-



- The memory card is write-protected.
 - Access to the memory card was restricted on another device.
-



- The amount of lights is not sufficient, so camera-shake easily occurs. Use the flash.
- The camcorder is unsteady, so camera-shake easily occurs. Hold the camcorder steady with both hands and record the image. However, note that the camera-shake warning indicator does not disappear.



- The recording medium is full.
- Photos cannot be recorded during processing. Wait for a while, then record.
- When set to the following, you cannot shoot photos during movie recording.
 - [REC Mode]: [Highest Quality **FX**]
 - [Frame Rate]: [60p] (models with the NTSC color system) or [50p] (models with the PAL color system)

Recording time of movies/number of recordable photos

For information on your camcorder model, see the following page:

Functions and equipment → p.11

“HD” stands for high definition image quality, and “STD” stands for standard definition image quality.

Expected time of recording and playback with each battery pack

Recording time

Approximate time available when you use a fully charged battery pack.

Continuous recording time (unit: minute)

Battery pack			
Image quality	HD	MP4	STD
NP-FV50	110	125	115
(supplied)	115	130	120

Typical recording time (unit: minute)

Battery pack			
Image quality	HD	MP4	STD
NP-FV50	55	60	55
(supplied)	55	65	60

- Top: When the LCD screen is opened
Bottom: When recording with the viewfinder without opening the LCD screen
- Each recording time is measured when the camcorder is recording high definition image quality (HD) movies with [ REC Mode] set to [Standard **HQ**].
- Typical recording time shows the time when you repeat recording start/stop, switching [Shooting Mode], and zooming.
- Times measured when using the camcorder at 25 °C (77 °F). 10 °C to 30 °C (50 °F to 86 °F) is recommended.

- The recording and playback time will be shorter, depending on the conditions under which you use your camcorder, such as when use your camcorder in low temperatures.

Playing time

Approximate time available when you use a fully charged battery pack.

(unit: minute)

Battery pack			
Image quality	HD	MP4	STD
NP-FV50	190	200	215
(supplied)	215	225	240

- Top: When the LCD screen is opened
Bottom: When recording with the viewfinder without opening the LCD screen

Expected recording time of movies

Internal memory

HDR-PJ780E/PJ780VE

High definition image quality (HD) in h (hour) and min (minute)

Recording mode	Recording time	
	HDR-PJ780E	HDR-PJ780VE
[50p Quality PS]/[60p Quality PS]	2 h 30 min (2 h 30 min)	2 h 15 min (2 h 15 min)
[Highest Quality FX]	3 h (3 h)	2 h 40 min (2 h 40 min)
[High Quality FH]	4 h 5 min (4 h 5 min)	3 h 40 min (3 h 40 min)
[Standard HQ]	7 h 15 min (5 h 30 min)	6 h 30 min (4 h 55 min)
[Long Time LP]	12 h 30 min (10 h 15 min)	11 h 15 min (9 h 15 min)

MP4 in h (hour) and min (minute)

Recording time	
HDR-PJ780E	HDR-PJ780VE
10 h 55 min (10 h 55 min)	9 h 55 min (9 h 55 min)

Standard definition image quality (STD) in h (hour) and min (minute)

Recording mode	Recording time	
	HDR-PJ780E	HDR-PJ780VE
[Standard <u>HQ</u>]	7 h 30 min (6 h 55 min)	6 h 45 min (6 h 15 min)

HDR-PJ790/PJ790E/PJ790V/PJ790VE

High definition image quality (HD) in h (hour) and min (minute)

Recording mode	Recording time	
	HDR-PJ790/PJ790E	HDR-PJ790V/ PJ790VE
[50p Quality <u>PS</u>]/[60p Quality <u>PS</u>]	7 h 45 min (7 h 45 min)	7 h 30 min (7 h 30 min)
[Highest Quality <u>FX</u>]	9 h 5 min (9 h 5 min)	8 h 50 min (8 h 50 min)
[High Quality <u>FH</u>]	12 h 25 min (12 h 25 min)	12 h (12 h)
[Standard <u>HQ</u>]	21 h 50 min (16 h 35 min)	21 h 10 min (16 h 5 min)
[Long Time <u>LP</u>]	37 h 45 min (31 h)	36 h 30 min (30 h)

MP4 in h (hour) and min (minute)

Recording time	
HDR-PJ790/PJ790E	HDR-PJ790V/PJ790VE
33 h (33 h)	32 h (32 h)

Standard definition image quality (STD) in h (hour) and min (minute)

Recording mode	Recording time	
	HDR-PJ790/PJ790E	HDR-PJ790V/ PJ790VE
[Standard <u>HQ</u>]	22 h 40 min (20 h 50 min)	21 h 55 min (20 h 10 min)

- If you want to record up to the maximum recording time indicated in the table, you need to delete the demonstration movie on your camcorder.

Memory card

High definition image quality (HD)

(unit: minute)

Recording mode	16 GB	32 GB	64 GB
[50p Quality <u>PS</u>]/[60p Quality <u>PS</u>]	75 (75)	150 (150)	305 (305)
[Highest Quality <u>FX</u>]	85 (85)	180 (180)	360 (360)
[High Quality <u>FH</u>]	120 (120)	245 (245)	490 (490)
[Standard <u>HQ</u>]	210 (160)	430 (325)	865 (655)
[Long Time <u>LP</u>]	370 (300)	740 (610)	1490 (1225)

MP4

(unit: minute)

16 GB	32 GB	64 GB
320 (320)	650 (650)	1305 (1305)

Standard definition image quality (STD)

(unit: minute)

Recording mode	16 GB	32 GB	64 GB
[Standard <u>HQ</u>]	220 (200)	445 (410)	895 (825)

- When using a Sony memory card.

Notes

- The recordable time may vary depending on the recording and subject conditions and [REC Mode] and [Frame Rate] (p. 52).
- The number in () is the minimum recordable time.
- You can record movies of a maximum of 3,999 scenes with high definition image quality (HD) and 9,999 scenes with standard definition image quality (STD). And you can record a maximum of 40,000 MP4 movies and photos collectively.
- The maximum continuous recording time of movies is approximately 13 hours.
- Your camcorder uses the VBR (Variable Bit Rate) format to automatically adjust image quality to suit the recording scene. This technology causes fluctuations in the recording time of the media. Movies containing quickly moving and complex images are recorded at a higher bit-rate, and this reduces the overall recording time.

Expected number of recordable photos

Internal memory

You can record a maximum of 40,000 MP4 movies and photos collectively.

Memory card

	16:9 24.1M
16 GB	1600
32 GB	3250
64 GB	6500

- When using a Sony memory card.
- The number of recordable photos of memory card shown is for the maximum image size of your camcorder. The actual number of recordable photos is displayed on the LCD screen during recording (p. 72).
- The number of recordable photos of memory card may vary depending on the recording conditions.

Notes

- The unique pixel array of Sony's ClearVid and the image processing system of Sony's BIONZ allows still image resolution equivalent to the sizes described.

On bit-rate and recording pixels

- The bit-rate, pixels and aspect ratio of each recording mode for movies (movie + audio, etc.)
Models with the NTSC color system:
 - High definition image quality (HD):
 - PS: Max. 28 Mbps 1,920 × 1,080 pixels/60p, AVC HD 28 M (PS), 16:9
 - FX: Max. 24 Mbps 1,920 × 1,080 pixels/60i or 1,920 × 1,080 pixels/24p, AVC HD 24 M (FX), 16:9
 - FH: Approx. 17 Mbps (average) 1,920 × 1,080 pixels/60i or 1,920 × 1,080 pixels/24p, AVC HD 17 M (FH), 16:9
 - HQ: Approx. 9 Mbps (average) 1,440 × 1,080 pixels/60i, AVC HD 9 M (HQ), 16:9
 - LP: Approx. 5 Mbps (average) 1,440 × 1,080 pixels/60i, AVC HD 5 M (LP), 16:9
 - MP4: Approx. 6 Mbps (average) 1,280 × 720 pixels/30p, 16:9
 - Standard definition image quality (STD):
 - HQ: Approx. 9 Mbps (average) 720 × 480 pixels/60i, STD 9 M (HQ), 16:9/4:3
- Models with the PAL color system:
 - High definition image quality (HD):
 - PS: Max. 28 Mbps 1,920 × 1,080 pixels/50p, AVC HD 28 M (PS), 16:9
 - FX: Max. 24 Mbps 1,920 × 1,080 pixels/50i, 1,920 × 1,080 pixels/25p or 1,920 × 1,080 pixels/24p ([24p Mode]), AVC HD 24 M (FX), 16:9
 - FH: Approx. 17 Mbps (average) 1,920 × 1,080 pixels/50i, 1,920 × 1,080 pixels/25p or 1,920 × 1,080 pixels/24p ([24p Mode]), AVC HD 17 M (FH), 16:9
 - HQ: Approx. 9 Mbps (average) 1,440 × 1,080 pixels/50i, AVC HD 9 M (HQ), 16:9
 - LP: Approx. 5 Mbps (average) 1,440 × 1,080 pixels/50i, AVC HD 5 M (LP), 16:9

About handling of your camcorder

- MP4: Approx. 6 Mbps (average) 1,280 × 720 pixels/25p, 16:9
- Standard definition image quality (STD):
HQ: Approx. 9 Mbps (average) 720 × 576 pixels/50i, STD 9 M (HQ), 16:9/4:3
- The photo recording pixels and the aspect ratio.
 - Photo recording mode, Dual capture:
6,544 × 3,680 dots/16:9
4,912 × 3,680 dots/4:3
4,672 × 2,628 dots/16:9
2,592 × 1,944 dots/4:3
1,920 × 1,080 dots/16:9
640 × 480 dots/4:3
 - Capturing a photo from a movie:
1,920 × 1,080 dots/16:9
640 × 360 dots/16:9
640 × 480 dots/4:3

On use and care

- The camcorder is not dustproofed, dripproofed or waterproofed.
- Do not hold the camcorder by the following parts, and also do not hold the camcorder by the jack covers.

Shoe cover



LCD screen



Battery pack

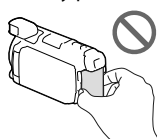

Built-in USB Cable

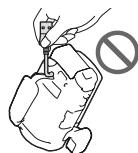

Viewfinder



Built-in microphone



Lens hood

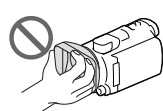

- Do not aim the camcorder at the sun. Doing so might cause your camcorder to malfunction. Take images of the sun only in low light conditions, such as at dusk.
- Do not use or store the camcorder and accessories in the following locations:

- Anywhere extremely hot, cold or humid. Never leave them exposed to temperatures above 60 °C (140 °F), such as under direct sunlight, near heaters or in a car parked in the sun. They may malfunction or become deformed.
- Near strong magnetic fields or mechanical vibration. The camcorder may malfunction.
- Near strong radio waves or radiation. The camcorder may not be able to record properly.
- Near tuner devices such as TVs or radio. Noise may occur.
- On a sandy beach or anywhere dusty. If sand or dust gets in your camcorder, it may malfunction. Sometimes this malfunction cannot be repaired.
- Near windows or outdoors, where the LCD screen, the viewfinder, or the lens may be exposed to direct sunlight. This damages the inside of the viewfinder or the LCD screen.
- For DC or AC operation, use the accessories recommended in these operating instructions.
- Do not let your camcorder get wet, for example, from rain or sea water. If your camcorder gets wet, it may malfunction. Sometimes this malfunction cannot be repaired.
- If any solid object or liquid gets inside the casing, unplug your camcorder and have it checked by a Sony dealer before operating it any further.
- Avoid rough handling, disassembling, modifying, physical shock, or impact such as hammering, dropping or stepping on the product. Be particularly careful with the lens.
- Keep the LCD screen and the viewfinder closed when you are not using your camcorder.
- Do not operate your camcorder with it wrapped in an object such as a towel.
- When disconnecting the power cord (mains lead), pull it by the plug and not the cord.
- Do not damage the power cord (mains lead) such as by placing anything heavy on it.
- Do not use a deformed or damaged battery pack.
- Keep metal contacts clean.
- If the battery electrolytic liquid has leaked:
 - Consult your local authorized Sony service facility.

- Wash off any liquid that may have contacted your skin.
- If any liquid gets in your eyes, wash with plenty of water and consult a doctor.

When not using your camcorder for a long time

- To keep your camcorder in optimum state for a long time, turn it on and let it run by recording and playing back images about once a month.
- Use up the battery pack completely before storing it.

Note on the camcorder/battery pack temperature

- When the temperature of the camcorder or battery pack becomes extremely high or extremely low, you may not be able to record or play back on the camcorder, due to the protection features of the camcorder being activated in such situations. In this case, an indicator appears on the LCD screen or the viewfinder.

Notes on charging through the USB cable

- Charging may not be possible with all computers.
- If you connect the camcorder to a laptop computer that is not connected to a power source, the battery of the laptop computer will continue to use up its charge. Do not leave the camcorder connected to a computer in this manner.
- Charging with a personally assembled computer, with a converted computer, or through a USB hub are not guaranteed. The camcorder may not function correctly depending on the USB device which is used with the computer.

When the camcorder is connected to a computer or accessories

- Do not try to format the recording media of the camcorder with a computer. If you do so, your camcorder may not operate correctly.
- When connecting the camcorder to another device with communication cables, be sure to insert the connector plug in the correct way. Pushing the plug forcibly into the terminal will damage the terminal and may result in a malfunction of the camcorder.
- When the camcorder is connected to other devices through a USB connection and the power of the camcorder is turned on, do not close the LCD panel. The image data that has been recorded may be lost.

Notes on optional accessories

- We recommend using genuine Sony accessories.
- Genuine Sony accessories may not be available in some countries/regions.

Multi interface shoe

- When using a dedicated microphone or portable speaker, their power turns on or off according to the power of your camcorder.
- Refer to the operating instructions supplied with the accessory used for details.
- To attach an accessory, insert and fix the accessory to the Multi interface shoe by pressing down and sliding until it stops.
- When you are recording movies with an external flash (sold separately) connected to the accessory shoe, turn off the power of the external flash to prevent charging noise from being recorded.
- You cannot use an external flash (sold separately) and the built-in flash at the same time.
- When an external microphone (sold separately) is connected, it takes precedence over the built-in microphone.

On Wireless Remote Commander

- Remove the insulation sheet before using the Wireless Remote Commander.

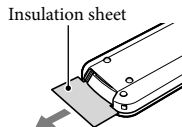

- Point the Wireless Remote Commander towards the remote sensor to operate your camcorder (p. 14).
- When no commands have been sent from the Wireless Remote Commander within a certain period, the light blue frame disappears. When you press any of ◀/▶/▲/▼, or ENTER again, the frame appears at the position where it was displayed last displayed.
- You cannot select some buttons on the LCD screen, or the viewfinder using ◀/▶/▲/▼.

To change the battery of the Wireless Remote Commander

- ① While pressing on the tab, inset your fingernail into the slit to pull out the battery case.
- ② Place a new battery with the + side facing up.
- ③ Insert the battery case back into the Wireless Remote Commander until it clicks.

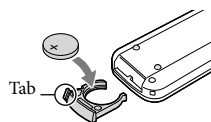

WARNING

Battery may explode if mistreated. Do not recharge, disassemble or dispose of in fire.

- When the lithium battery becomes weak, the operating distance of the Wireless Remote Commander may shorten, or the Wireless Remote Commander may not function properly. In this case, replace the battery with a Sony CR2025 lithium battery. Use of another battery may present a risk of fire or explosion.

On handling the LCD screen

- If you leave fingerprints, hand cream, etc. on the LCD screen, the coating of the LCD screen will come off easily. Wipe those off as soon as possible.
- If you wipe the LCD screen strongly with a tissue, etc., the coating of the LCD screen may be scratched.
- If the LCD screen becomes dirty with fingerprints or dust, it is recommended that you gently remove those from the screen then clean it with a soft cloth, etc.

LCD screen

- Do not apply excessive pressure on the LCD screen, as it may cause uneven color and other damage.
- If your camcorder is used in a cold place, a residual image may appear on the LCD screen. This is not a malfunction.
- While using your camcorder, the back of the LCD screen may heat up. This is not a malfunction.

To clean the casing and the projector lens

- Wipe the casing and the lens gently with a soft cloth such as a cleaning cloth or eyeglass cleaning cloth.
- If the casing and the projector lens is very dirty, clean the camcorder casing and the lens with a soft cloth lightly moistened with water, and then wipe the casing and the projector lens with a dry soft cloth.
- Avoid the following so as not to deform the casing, damage the finish or scratch the lens:
 - Using chemicals such as thinner, benzine, alcohol, chemical cloths, insect repellent, insecticide and sunscreen
 - Handling the camcorder with the above substances on your hands
 - Leaving the camcorder in contact with rubber or vinyl objects for a long period of time

On handling the light-emitting part of flash

If the LCD screen becomes dirty with fingerprints or dust, it is recommended that you use a soft cloth to clean it.

About the Carl Zeiss lens

Your camcorder is equipped with a Carl Zeiss lens, which was developed jointly by Carl Zeiss, in Germany, and Sony Corporation, and produces superior images. It adopts the MTF measurement system for video cameras and offers a quality typical of a Carl Zeiss lens. Also, the lens for your camcorder is T*-coated to suppress unwanted reflections and faithfully reproduce colors.

MTF= Modulation Transfer Function. The number value indicates the amount of light from a subject coming into the lens.

About care and storage of the lens

- Wipe the surface of the lens clean with a soft cloth in the following instances:
 - When there are fingerprints on the lens surface
 - In hot or humid locations
 - When the lens is exposed to salty air such as at the seaside
- Store in a well-ventilated location subject to little dirt or dust.
- To prevent mold, periodically clean and store the lens as described above.

Specifications

On charging the pre-installed rechargeable battery

Your camcorder has a pre-installed rechargeable battery to retain the date, time, and other settings even when the LCD screen is closed. The pre-installed rechargeable battery is always charged while your camcorder is connected to the wall outlet (wall socket) via the AC Adaptor or while the battery pack is attached. The rechargeable battery will be fully discharged in about 3 months if you do not use your camcorder at all. Charge the pre-installed rechargeable battery before you start using your camcorder.

However, even if the pre-installed rechargeable battery is not charged, the camcorder operation other than date recording will not be affected.

How to charge the pre-installed rechargeable battery

Connect your camcorder to a wall outlet (wall socket) using the supplied AC Adaptor, and leave it with the LCD screen closed for more than 24 hours.

Note on disposal/transfer the ownership of the camcorder

Even if you delete all movies and still images, or perform [Format] (p. 53), data on the internal memory may not be completely erased. It is recommended that you select **MENU** → [Setup] → [Media Settings] → [Format] → [Empty] to prevent the recovery of your data.

System

Signal format:

NTSC color, EIA standards (HDR-PJ780E*7/
PJ780VE*7/PJ790/PJ790E*7/PJ790V/
PJ790VE*7)

PAL color, CCIR standards (HDR-PJ780E/
PJ780VE/PJ790E/PJ790VE)

HD TV

*7 [24p Mode]

Movie recording format:

AVCHD (AVCHD format Ver.2.0

compatible):

Video: MPEG-4 AVC/H.264

Audio: Dolby Digital 2ch/5.1ch Dolby Digital
5.1 Creator*1

MPEG-2 PS:

Video: MPEG-2 (Video)

Audio: Dolby Digital 2ch/5.1ch Dolby Digital
5.1 Creator*1

MP4:

Video: MPEG-4 AVC/H.264

Audio: MPEG-4 AAC-LC 2ch

*1 Manufactured under license from Dolby
Laboratories.

Photo file format:

DCF Ver.2.0 Compatible

Exif Ver.2.3 Compatible

MPF Baseline Compatible

Recording media (Movie/Photo):

Internal memory

HDR-PJ780E/PJ780VE: 32 GB

HDR-PJ790/PJ790E/PJ790V/PJ790VE: 96 GB

“Memory Stick PRO Duo” media

SD card (Class 4 or faster)

The capacity that a user can use (Approx.)

HDR-PJ780E: 31.1 GB*3

HDR-PJ780VE: 28.1 GB*2

HDR-PJ790/PJ790E: 93.7 GB*3

HDR-PJ790V/PJ790VE: 90.6 GB*2

*2 1 GB equals 1 billion bytes, 2.8 GB is used for pre-installed map and another portion is used for data management functions. Only pre-installed demonstration movie may be deleted.

*3 1 GB equals 1 billion bytes, a portion of which is used for system management and/or application files. Only pre-installed demonstration movie may be deleted.

Viewfinder:

Electronic viewfinder (color)

Image device:

6.3 mm (1/2.88 type) CMOS Sensor
Recording pixels (photo, 16:9):
Max. 24.1 mega (6 544 × 3 680) pixels*4
Gross: Approx. 6 650 000 pixels
Effective (movie, 16:9)*5:
Approx. 6 140 000 pixels
Effective (photo, 16:9):
Approx. 6 140 000 pixels
Effective (photo, 4:3):
Approx. 4 600 000 pixels

Lens:

Carl Zeiss Vario-Sonnar T*
10 × (Optical)*5, 17 × (Extended, while recording movies)*6, 120 × (Digital)
Filter diameter: 52 mm (2 1/8 in.)
37 mm (1 1/2 in.) (When attaching the Step Down Ring)
F1.8 ~ F3.4
Focal length:
f = 3.8 mm ~ 38.0 mm (5/32 in. ~ 1 1/2 in.)
When converted to a 35 mm still camera
For movies*5: 26.0 mm ~ 260 mm (1 1/16 in. ~ 10 1/4 in.) (16:9)
For photos: 26.0 mm ~ 260 mm (1 1/16 in. ~ 10 1/4 in.) (16:9)

Color temperature: [Auto], [One Push], [Indoor], [Outdoor]

Minimum illumination:

6 lx (lux) (in default setting, shutter speed 1/60 second (HDR-PJ790/PJ790V) or 1/50 second (HDR-PJ780E/PJ780VE/PJ790E/PJ790VE))
3 lx (lux) ([Low Lux] is set to [On], shutter speed 1/30 second (HDR-PJ790/PJ790V) or 1/25 second (HDR-PJ780E/PJ780VE/PJ790E/PJ790VE))
0 lx (lux) (NIGHTSHOT is set to [On])

*4 The unique pixel array of Sony's ClearVid and the image processing system (BIONZ) allow still image resolution equivalent to the sizes described.

*5 [SteadyShot] is set to [Standard] or [Off].

*6 [SteadyShot] is set to [Active].

Input/Output connectors

HDMI OUT jack: HDMI micro connector
PROJECTOR IN jack: HDMI micro connector
MIC input jack: Stereo minijack (φ 3.5 mm)
Headphone jack: Stereo minijack (φ 3.5 mm)
USB jack: Type A (Built-in USB)

Multi/Micro USB Terminal*

* Supports Micro USB compatible devices.

- USB connection is only for output (HDR-PJ780E/PJ780VE/PJ790E/PJ790VE).

LCD screen

Picture: 7.5 cm (3.0 type, aspect ratio 16:9)
Total number of pixels:
921 600 (1 920 × 480)

Projector

Projection type: DLP
Light source: LED (R/G/B)
Focus: Manual
Throw Distance: 0.5 m (1.6 feet) or over
Contrast ratio: 1200:1
Resolution (output): WVGA (854 × 480)
Continuous projection time (when using the supplied battery pack):
Approx. 1 h 35 min.

General

Power requirements: DC 6.8 V/7.2 V (battery pack) DC 8.4 V (AC Adaptor)

USB Charging: DC 5 V 500 mA/1.5 A

Average power consumption:

During camera recording using the viewfinder at normal brightness:

HD: 3.2 W MP4: 2.9 W STD: 3.1 W

During camera recording using LCD screen at normal brightness:

HD: 3.4 W MP4: 3.0 W STD: 3.2 W

Operating temperature: 0 °C to 40 °C (32 °F to 104 °F)

Storage temperature: -20 °C to +60 °C (-4 °F to +140 °F)

Dimensions (approx.):

74.2 mm × 84.6 mm × 137.5 mm (3 in. × 3 3/8 in. × 5 1/2 in.) (w/h/d) including the projecting parts

107.5 mm × 87.5 mm × 166 mm (4 1/4 in. × 3 1/2 in. × 6 5/8 in.) (w/h/d) including the projecting parts, the supplied rechargeable battery pack attached, and the lens hood

Mass (approx.)

HDR-PJ780E/PJ790/PJ790E:

570 g (1 lb 4.1 oz) main unit only

670 g (1 lb 7.6 oz) including the supplied rechargeable battery pack, and the lens hood

HDR-PJ780VE/PJ790V/PJ790VE:
575 g (1 lb 4.3 oz) main unit only
675 g (1 lb 7.8 oz) including the supplied
rechargeable battery pack, and the lens hood

AC Adaptor AC-L200C/AC-L200D

Power requirements: AC 100 V - 240 V,
50 Hz/60 Hz

Current consumption: 0.35 A - 0.18 A

Power consumption: 18 W

Output voltage: DC 8.4 V*

Operating temperature: 0 °C to 40 °C (32 °F to
104 °F)

Storage temperature: -20 °C to +60 °C (-4 °F to
+140 °F)

Dimensions (approx.): 48 mm × 29 mm ×
81 mm (1 15/16 in. × 1 3/16 in. × 3 1/4 in.)
(w/h/d) excluding the projecting parts

Mass (approx.): 150 g (5.3 oz) excluding the
power cord (mains lead)

* See the label on the AC Adaptor for other
specifications.

Rechargeable battery pack NP-FV50

Maximum output voltage: DC 8.4 V

Output voltage: DC 6.8 V

Maximum charge voltage: DC 8.4 V

Maximum charge current: 2.1 A

Capacity

Typical: 7.0 Wh (1 030 mAh)

Minimum: 6.6 Wh (980 mAh)

Type: Li-ion

Design and specifications of your camcorder and
accessories are subject to change without notice.

On trademarks

- “Handycam” and **HANDYCAM** are registered trademarks of Sony Corporation.
- “AVCHD”; “AVCHD Progressive”; “AVCHD” logotype and “AVCHD Progressive” logotype are trademarks of Panasonic Corporation and Sony Corporation.
- “Memory Stick,”  “Memory Stick Duo,” **“MEMORY STICK DUO”**, “Memory Stick PRO Duo,” **“MEMORY STICK PRO DUO”**, “Memory Stick PRO-HG Duo,” **“MEMORY STICK PRO-HG DUO”**, “Memory Stick XC-HG Duo,” **“MEMORY STICK XC-HG DUO”**, “MagicGate,” **“MAGIC GATE”**, “MagicGate Memory Stick” and “MagicGate Memory Stick Duo” are trademarks or registered trademarks of Sony Corporation.
- “InfoLITHIUM” is a trademark of Sony Corporation.
- “x.v.Color” and “x.v.Colour” are trademarks of Sony Corporation.
- “BIONZ” is a trademark of Sony Corporation.
- **S-MASTER** is a registered trademark of Sony Corporation.
- “BRAVIA” is a trademark of Sony Corporation.
- Blu-ray Disc™ and Blu-ray™ are trademarks of the Blu-ray Disc Association.
- Dolby and the double-D symbol are trademarks of Dolby Laboratories.
- The terms HDMI and HDMI High-Definition Multimedia Interface, and the HDMI Logo are trademarks or registered trademarks of HDMI Licensing LLC in the United States and other countries.
- Microsoft, Windows, Windows Vista, and DirectX are either registered trademarks or trademarks of Microsoft Corporation in the United States and/or other countries.
- Mac and Mac OS are registered trademarks of Apple Inc. in the U.S. and other countries.
- Intel, Intel Core, and Pentium are trademarks or registered trademarks of Intel Corporation or its subsidiaries in the United States and other countries.
-  and “PlayStation” are registered trademarks of Sony Computer Entertainment Inc.
- NAVTEQ and the NAVTEQ Maps logo are trademarks of NAVTEQ in the US and other countries.

- SDXC logo is a trademark of SD-3C, LLC.
- MultiMediaCard is a trademark of MultiMediaCard Association.
- Facebook and the “f” logo are trademarks or registered trademarks of Facebook, Inc.
- YouTube and the YouTube logo are trademarks or registered trademarks of Google Inc.

All other product names mentioned herein may be the trademarks or registered trademarks of their respective companies. Furthermore, TM and [®] are not mentioned in each case in this manual.



Add further enjoyment with your PlayStation 3 by downloading the application for PlayStation 3 from PlayStation Store (where available.)

The application for PlayStation 3 requires PlayStation Network account and application download.

Accessible in areas where the PlayStation Store is available.

END-USER LICENSE AGREEMENT FOR MAP DATA FOR VIDEO CAMERA RECORDER PRODUCTS (Models with GPS)

YOU SHOULD CAREFULLY READ THE FOLLOWING AGREEMENT BEFORE USING THIS SOFTWARE.

IMPORTANT-READ CAREFULLY: This End-User License Agreement (“LICENSE”) is a legal agreement between you and Sony Corporation (“SONY”), the licensor of the map data included in your video camera recorder product (“PRODUCT”). Such map data, including subsequent updates/upgrades, is referred to herein as the SOFTWARE. This LICENSE covers only the SOFTWARE. You may use the SOFTWARE only in connection with your use of the PRODUCT. By touching the “AGREE” button appearing on the screen of the PRODUCT in connection with this License, you agree to be bound by the terms of this LICENSE. If you do not agree to the terms of this LICENSE, SONY is unwilling to license the SOFTWARE to you. In such event, the SOFTWARE will not be available and you may not use the SOFTWARE.

SOFTWARE LICENSE

The SOFTWARE is protected by copyright laws and international copyright treaties, as well as other intellectual property laws and treaties. The SOFTWARE is licensed, not sold.

GRANT OF LICENSE

This LICENSE grants you the following rights on a non-exclusive basis: SOFTWARE. You may use the SOFTWARE on one unit of the PRODUCT. Use. You may use the SOFTWARE for its own use.

DESCRIPTION OF OTHER RIGHTS AND LIMITATIONS

Restrictions. You may not transfer or distribute any part of the SOFTWARE in any form for any purpose except as expressly permitted in this LICENSE. You may not use the SOFTWARE with any products, systems or applications other than with the PRODUCT. Except as otherwise provided in this LICENSE, you may not use and may not permit any third party to use the SOFTWARE separated from the PRODUCT (in whole or in part, including, but

not limited to, reproductions, outputs or extractions or other works thereof (in any form) for the purpose of rental or lease whether with any license fee or not. Some jurisdictions do not allow the restrictions of such rights, in such case the above restrictions may not apply to you.

Limitation on Reverse Engineering, Decompilation and Disassembly. You may not (i) extract the SOFTWARE from the PRODUCT, (ii) reproduce, copy, modify, port, translate, or create derivative works of the SOFTWARE in whole or in part, or (iii) reverse engineer, decompile, disassemble the SOFTWARE by any means whatsoever in whole or in part for any purpose. Some jurisdictions do not allow the limitation of such rights, in such case the above limitation may not apply to you.

Trademarks and Notices: You may not remove, alter, cover or deface any trademarks or copyright notices on the SOFTWARE.

Data Files. The SOFTWARE may create data files automatically for use with the SOFTWARE. Any such data files will be deemed to be part of the SOFTWARE.

SOFTWARE Transfer. You may permanently transfer all of your rights under this LICENSE only as part of a sale or transfer of the PRODUCT, provided you retain no copies of the SOFTWARE, transfer all of the SOFTWARE (including all copies (only if permitted to copy under "Limitation on Reverse Engineering, Decompilation and Disassembly" Paragraph above), component parts, the media and printed materials, all versions and any upgrades of the SOFTWARE and this LICENSE), and the recipient agrees to the terms and conditions of this LICENSE.

Termination. Without prejudice to any other rights, SONY may terminate this LICENSE if you fail to comply with the terms and conditions of this LICENSE. In such event, you must stop using the SOFTWARE and all of its component parts. The provisions of this LICENSE "COPYRIGHT," "HIGH RISK ACTIVITIES," "EXCLUSION OF WARRANTY ON SOFTWARE," "LIMITATION OF LIABILITY," "PROHIBITION ON EXPORT," "SEVERABILITY," and "GOVERNING LAW AND JURISDICTION" Sections, "Confidentiality" Paragraph of this Section and this Paragraph shall survive any expiration or termination of this LICENSE.

Confidentiality. You agree to keep information contained in the SOFTWARE which is not publicly known confidential to yourself, and not to disclose such information to others without SONY's prior written approval.

COPYRIGHT

All title and copyright in and to the SOFTWARE (including but not limited to any map data, images, photographs, animation, video, audio, music, text and "applets," incorporated into the SOFTWARE), and any copies of the SOFTWARE, are owned by SONY,

licensors and suppliers to SONY and their respective affiliates (such licensors and suppliers to SONY, together with their respective affiliates, are hereinafter collectively referred to as "SONY's Licensors"). All rights not specifically granted under this LICENSE are reserved by SONY or SONY's Licensors.

HIGH RISK ACTIVITIES

The SOFTWARE is not fault-tolerant and is not designed, manufactured or intended for use in hazardous environments requiring fail-safe performance, such as in the operation of nuclear facilities, aircraft navigation or communication systems, air traffic control, direct life support machines, or weapons systems, in which the failure of the SOFTWARE could lead to death, personal injury, or severe physical or environmental damage ("High Risk Activities"). SONY, its affiliates, their respective suppliers and SONY's Licensors specifically disclaim any express or implied warranty of fitness for High Risk Activities.

EXCLUSION OF WARRANTY ON SOFTWARE

You expressly acknowledge and agree that use of the SOFTWARE is at your sole risk. The SOFTWARE is provided "AS IS" and without warranty of any kind and SONY, its affiliates, its and their respective suppliers and SONY's Licensors (in this section, SONY, its affiliates, their respective suppliers and SONY's Licensors shall be collectively referred to as "SONY") EXPRESSLY DISCLAIMS ALL WARRANTIES AND CONDITIONS, EXPRESS OR IMPLIED, ARISING BY LAW OR OTHERWISE, INCLUDING, BUT NOT LIMITED TO, THE IMPLIED WARRANTIES AND CONDITIONS OF QUALITY, NON-INFRINGEMENT, MERCHANTABILITY AND FITNESS FOR A PARTICULAR PURPOSE. SONY DOES NOT WARRANT THAT THE FUNCTIONS CONTAINED IN THE SOFTWARE WILL MEET YOUR REQUIREMENTS, OR THAT THE OPERATION OF THE SOFTWARE WILL BE UNINTERRUPTED OR ERROR FREE. SONY DOES NOT WARRANT OR MAKE ANY REPRESENTATIONS REGARDING THE USE, INABILITY TO USE OR THE RESULTS OF THE USE OF THE SOFTWARE IN TERMS OF ITS CORRECTNESS, ACCURACY, RELIABILITY, OR OTHERWISE. SOME JURISDICTIONS DO NOT ALLOW THE EXCLUSION OF IMPLIED WARRANTIES, IN SUCH CASE THE ABOVE EXCLUSIONS MAY NOT APPLY TO YOU.

You expressly understand that the data in the SOFTWARE may contain inaccurate or incomplete information due to the passage of time, changing circumstances, sources used and the nature of collecting comprehensive geographic data, any of which may lead to incorrect results.

LIMITATION OF LIABILITY

IN THIS SECTION SONY, ITS AFFILIATES, ITS AND THEIR RESPECTIVE SUPPLIERS AND SONY'S LICENSORS SHALL BE COLLECTIVELY REFERRED TO AS "SONY" TO THE MAXIMUM EXTENT PERMITTED UNDER APPLICABLE LAW. SONY SHALL NOT BE LIABLE FOR ANY CLAIM, DEMAND OR ACTION, IRRESPECTIVE OF THE NATURE OF THE CAUSE OF CLAIM, DEMAND OR ACTION, ALLEGING ANY LOSS OR DAMAGES, DIRECT OR INDIRECT, WHICH MAY RESULT FROM THE USE OR POSSESSION OF THE SOFTWARE; NOR FOR ANY LOSS OF PROFIT, REVENUE, CONTRACTS OR SAVINGS, NOR ANY OTHER DIRECT, INDIRECT, INCIDENTAL, SPECIAL OR CONSEQUENTIAL DAMAGES ARISING OUT OF YOUR USE OF OR INABILITY TO USE THE SOFTWARE, ANY DEFECT IN THE SOFTWARE, OR THE BREACH OF THE TERMS AND CONDITIONS, WHETHER IN AN ACTION IN CONTRACT OR TORT OR BASED ON A WARRANTY, EVEN IF SONY HAS BEEN ADVISED OF THE POSSIBILITY OF SUCH DAMAGES EXCEPT IN THE EVENT OF SONY'S GROSS NEGLIGENCE OR WILLFUL MISCONDUCT, OF DEATH OR PERSONAL INJURY, AND OF DAMAGES DUE TO THE DEFECTIVE NATURE OF THE PRODUCT. IN ANY CASE, SAVE FOR THE FOREGOING EXCEPTIONS, SONY'S ENTIRE LIABILITY UNDER ANY PROVISION OF THIS LICENSE SHALL BE LIMITED TO THE AMOUNT ACTUALLY PAID ALLOCATABLE TO THE SOFTWARE. SOME JURISDICTIONS DO NOT ALLOW THE EXCLUSION OR LIMITATION OF CONSEQUENTIAL OR INCIDENTAL DAMAGES, SO THE ABOVE EXCLUSION OR LIMITATION MAY NOT APPLY TO YOU.

PROHIBITION ON EXPORT

YOU ACKNOWLEDGE THAT THE USE OF THE SOFTWARE IN SOME COUNTRIES, REGIONS, AREAS OR FACILITIES, OR THE EXPORT OF THE PRODUCTS FROM THE COUNTRY WHERE SUCH PRODUCTS ARE DESIGNED TO BE SOLD, MAY BE RESTRICTED OR PROHIBITED. YOU AGREE TO USE THE SOFTWARE OR EXPORT THE PRODUCTS IN ACCORDANCE WITH THE APPLICABLE LAWS, ORDINANCES, RULES AND REGULATIONS OF RELEVANT COUNTRIES, REGIONS, AREAS AND FACILITIES.

SEVERABILITY

If any part of this LICENSE is held invalid or unenforceable, the other parts will remain valid.

GOVERNING LAW AND JURISDICTION

This LICENSE shall be governed by the laws of Japan without giving effect to its conflict of laws

provisions or the United Nations Convention for Contracts for the International Sale of Goods, which is expressly excluded. Any dispute arising out of this LICENSE shall be subject to the exclusive venue of the Tokyo District Court, and the parties hereby consent to the venue and jurisdiction of such court. THE PARTIES HEREBY WAIVE TRIAL BY JURY WITH RESPECT TO ANY MATTERS ARISING UNDER OR RELATING TO THIS LICENSE. SOME JURISDICTIONS DO NOT ALLOW THE EXCLUSION OF THE RIGHT OF TRIAL BY JURY, IN SUCH CASE THE ABOVE EXCLUSION MAY NOT APPLY TO YOU.

ENTIRE AGREEMENT

These terms and conditions constitute the entire agreement between SONY and you pertaining to the subject matter hereof, and supersedes in their entirety any and all previously existing written or oral agreements between us with respect to such subject matter.

GOVERNMENT END USERS

If the SOFTWARE is being acquired by or on behalf of the United States government or any other entity seeking or applying rights similar to those customarily claimed by the United States government, such SOFTWARE is a "commercial item" as that term is defined at 48 C.F.R. ("FAR") 2.101, is licensed in accordance with this LICENSE, and such SOFTWARE delivered or otherwise furnished shall be provided with the following "Notice of Use" and shall be treated in accordance with such notice:

NOTICE OF USE

CONTRACTOR (MANUFACTURER/
SUPPLIER) NAME: SONY CORPORATION/
CONTRACTOR (MANUFACTURER/
SUPPLIER) ADDRESS: 1-7-1 Konan, Minato-
ku, Tokyo, Japan

These SOFTWARE are commercial items as defined in FAR 2.101 and are subject to the **END-USER LICENSE AGREEMENT FOR MAP DATA FOR VIDEO CAMERA RECORDER PRODUCTS** under which this SOFTWARE was provided.

If the Contracting Officer, federal government agency, or any federal official refuses to use the legend provided herein, the Contracting Officer, federal government agency, or any federal official must notify SONY prior to seeking additional or alternative rights in the Software.

Copyright and trademark information

©1993-2011 NAVTEQ
©2012 ZENRIN CO., LTD.

Australia

© Hema Maps Pty. Ltd, 2010.
Copyright. Based on data provided under license from PSMA Australia Limited (www.pasma.com.au). Product incorporates data which is © 2010 Telstra Corporation Limited, GM Holden Limited, Intelomatics Australia Pty Ltd, NAVTEQ International LLC, Sentinel Content Pty Limited and Continental Pty Ltd.

Austria

© Bundesamt für Eich- und Vermessungswesen

Canada

This data includes information taken with permission from Canadian authorities, including © Her Majesty the Queen in Right of Canada, © Queen's Printer for Ontario, © Canada Post Corporation, GeoBase®, © The Department of Natural Resources Canada. All rights reserved.

Croatia, Estonia, Latvia, Lithuania, Moldova, Poland, Slovenia and Ukraine

© EuroGeographic

France

source: © IGN 2009 - BD TOPO®

Germany

Die Grundlagendaten wurden mit Genehmigung der zustandigen Behoerden entnommen.

Great Britain

Contains Ordnance Survey data © Crown copyright and database right 2010
Contains Royal Mail data © Royal Mail copyright and database right 2010

Greece

Copyright Geomatics Ltd.

Hungary

Copyright © 2003; Top-Map Ltd.

Italy

La Banca Dati Italiana è stata prodotta usando quale riferimento anche cartografia numerica ed al tratto prodotta e fornita dalla Regione Toscana.

Japan

- 日本の地図の作成にあたっては、国土地理院長の承認を得て、同院発行の2万5千分の1地形図を使用しています。(承認番号 平20業使、第204-46号)
- 日本の地図の作成にあたっては、国土地理院長の承認を得て、同院の技術資料H-1-No.3「日本測地系における離島位置の補正量」を使用しています。(承認番号 国地企調発第78号 平成16年4月23日)

Jordan

© Royal Jordanian Geographic Centre

Mexico

Fuente: INEGI (Instituto Nacional de Estadística y Geografía.)

Norway

Copyright © 2000; Norwegian Mapping Authority

Portugal

Source: IgeoE – Portugal

Spain

Información geográfica propiedad del CNIG

Sweden

Based upon electronic data © National Land Survey Sweden.

Switzerland

Topografische Grundlage: © Bundesamt für Landestopographie.

United States

©United States Postal Service® 2010. Prices are not established, controlled or approved by the United States Postal Service®.
The following trademarks and registrations are owned by the USPS: United States Postal Service, USPS, and ZIP+4.

Screen indicators

The following indicators appear when you change the settings. See page 29 also for the indicators that appear during recording or playing.

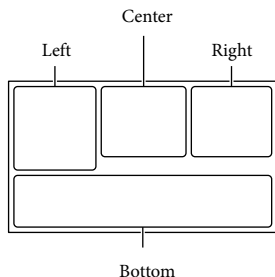

Left

Indicator	Meaning
	MENU button (50)
	Self-timer recording (51)
	GPS triangulation status (37)
	[Airplane Mode] set to [On] (53)
	Video light
	Wide Mode (52)
	Fader (51)
	[Face Detection] set to [Off] (52)
	[Smile Shutter] set to [Off] (52)
	Manual focus (51)
	Scene Selection (51)
	White Balance (51)
	SteadyShot off (51)
	White Balance Shift (51)
	Tele Macro (51)
	Conversion Lens (51)
	Zebra (52)
	Peaking (52)
	Cinematone (51)
	Destination (54)

	Intelligent Auto (face detection/scene detection/camera-shake detection/sound detection) (35)
--	---

Center





Indicator	Meaning
	Slideshow Set (32)
	NightShot
	Warning (56)
	Playback mode (31)

Right

Indicator	Meaning
	Recording image quality (HD/MP4/STD), frame rate (60p/50p/60i/50i/24p/25p), recording mode (PS/FX/FH/HQ/LP) and movie size (34)
	Remaining battery
	Recording/playback/editing media (25)
	Counter (hour:minute:second)
	Estimated remaining recording time
	Approximate number of recordable photos and photo size (52)
	Playback folder
	Current playing movie or photo/Number of total recorded movies or photos
	Connection to the external media device (48)

Bottom

Indicator	Meaning
	Audio Rec Level (52)
	[Auto Wind NR] set to [Off] (52)
	[Closer Voice] set to [Off] (52)
	Blt-in Zoom Mic (52)
	Audio Mode (52)
	Low Lux (51)

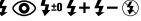
AGC	AGC Limit (51)
	Spot Meter/Fcs (51)/Spot Meter (51)/ Exposure (51)
EV	AE Shift (51)
10000	Shutter Speed (51)
F1.8	IRIS (51)
i 	Intelligent Auto (35)
 101-0005	Data file name
	Protect (53)
	Flash (52)/Flash Level (52)/Red Eye Reduction (52)

- Indicators and their positions are approximate and may differ from what you actually see.
- Some indicators may not appear, depending on your camcorder model.

Index

Symbols

5.1ch surround sound.....38

A

AVCHD recording disc.....10, 34

B

Battery pack.....19

Beep.....24

Built-in USB Cable.....20

C

Care.....61

Charging the battery pack.....19

Charging the battery pack using
your computer.....20

Computer.....44

Creating discs.....46

D

Data Code.....24

Date/Time.....24

Delete.....41

Direct Copy.....48

Display items on the LCD
screen.....28

Divide.....41

Dual Capture.....27

E

Editing.....41

Event View.....31

Extended Zoom.....30

External media device.....46, 47

F

FH.....34

Full charge.....20

FX.....34

G

GPS.....37

Grip belt.....16

H

“Handycam” User Guide.....10

HDMI Cable.....37

How to use this manual.....11

HQ.....34

I

Initial setup.....22

Install.....44

Intelligent Auto.....35

IRIS.....51

L

Language.....9

LCD screen.....28

Lens hood.....16

LP.....34

M

Mac.....43

MANUAL dial.....36

Map View.....33

Media Select.....25

Media Settings.....25

Memory card.....25

“Memory Stick PRO-HG Duo”
media.....26

“Memory Stick PRO Duo” media
(Mark2).....26

“Memory Stick XC-HG Duo”
media.....26

Menu lists.....51

Menus.....50

Mirror mode.....30

Movies.....27

Multi interface shoe.....14, 63

N

Notes on handling of your
camcorder.....61

Number of recordable photos...60

P

Parts and controls.....14

Photo Capture.....42

Photos.....28

Playback.....31

PlayMemories Home.....18, 43, 44

PlayMemories Home Help
Guide.....18, 45

Power on.....22

Projector.....39

PS.....34

R

REC Mode.....34

Recording.....27

Recording and playback time...58

Recording media.....25

Recording time of movies.....58

Repair.....55

RESET.....15

S

Saving images on an external
media device.....46, 47

Screen indicators.....29, 72

SD card.....26

Self-diagnosis display.....56

Setting the date and time.....22

Smile Shutter.....34

Specifications.....65

Starting PlayMemories Home...45

Step down ring.....16

Summer Time.....22

Supplied Items.....18

T

Thumbnails.....32

Touch panel.....28

Tripod.....16

Troubleshooting.....55

TV.....37

U	
USB.....	20
USB Adaptor Cable	47
USB connection support cable.....	18
V	
VBR	60
W	
Wall outlet (wall socket)	21
Warning indicators.....	56
Wind noise	52
Windows.....	44
Wind screen	17
Wireless Remote Commander	17, 63
Z	
Zoom.....	30

You will find the menu lists
on pages 51 to 54

Additional information on this product and answers to frequently asked questions can be found at our Customer Support Website.

<http://www.sony.net/>

