

Symmetra™ PX

10–40 kW 208 V

Installation

01/2016



Legal Information

The Schneider Electric brand and any registered trademarks of Schneider Electric Industries SAS referred to in this guide are the sole property of Schneider Electric SA and its subsidiaries. They may not be used for any purpose without the owner's permission, given in writing. This guide and its content are protected, within the meaning of the French intellectual property code (Code de la propriété intellectuelle français, referred to hereafter as "the Code"), under the laws of copyright covering texts, drawings and models, as well as by trademark law. You agree not to reproduce, other than for your own personal, noncommercial use as defined in the Code, all or part of this guide on any medium whatsoever without Schneider Electric's permission, given in writing. You also agree not to establish any hypertext links to this guide or its content. Schneider Electric does not grant any right or license for the personal and noncommercial use of the guide or its content, except for a non-exclusive license to consult it on an "as is" basis, at your own risk. All other rights are reserved.

Electrical equipment should be installed, operated, serviced, and maintained only by qualified personnel. No responsibility is assumed by Schneider Electric for any consequences arising out of the use of this material.

As standards, specifications, and designs change from time to time, please ask for confirmation of the information given in this publication.

Table of Contents

Important Safety Information	5
Safety Precautions	6
Electrical Safety	8
Battery Safety	9
Product Specific Safety Information	10
Specifications	11
AC Input Specifications	11
AC Bypass Input Specifications	11
AC Output Specifications	11
Battery Specifications	12
Heat Dissipation	12
Recommended Cable Sizes	12
Recommended Cable Lugs and Crimping Tool	12
Overcurrent Protective Devices in Single Systems	13
Mechanical Assembly	14
Prepare for Cables	14
Prepare for Cables in a Bottom Cable Entry System	14
Prepare for Cables in a Rear Cable Entry System	14
Rearrange Side Panels for Line-Up and Match Modular Battery Cabinets	15
Level the Cabinets	16
Connect the Power Cables	18
Connect the EPO	20
Connect Communication Cables	23
Install Modular Battery Cabinet (Option)	26
Connect Battery Cables in Modular Battery Cabinet	26
Connect the Battery Cables between the Modular Battery Cabinets	26
Install Maintenance Bypass Enclosure (Option)	29

Important Safety Information

Read these instructions carefully and look at the equipment to become familiar with it before trying to install, operate, service or maintain it. The following safety messages may appear throughout this manual or on the equipment to warn of potential hazards or to call attention to information that clarifies or simplifies a procedure.



The addition of this symbol to a “Danger” or “Warning” safety message indicates that an electrical hazard exists which will result in personal injury if the instructions are not followed.



This is the safety alert symbol. It is used to alert you to potential personal injury hazards. Obey all safety messages with this symbol to avoid possible injury or death.

⚠ DANGER
<p>DANGER indicates a hazardous situation which, if not avoided, will result in death or serious injury.</p> <p>Failure to follow these instructions will result in death or serious injury.</p>

⚠ WARNING
<p>WARNING indicates a hazardous situation which, if not avoided, could result in death or serious injury.</p> <p>Failure to follow these instructions can result in death, serious injury, or equipment damage.</p>

⚠ CAUTION
<p>CAUTION indicates a hazardous situation which, if not avoided, could result in minor or moderate injury.</p> <p>Failure to follow these instructions can result in injury or equipment damage.</p>

NOTICE
<p>NOTICE is used to address practices not related to physical injury. The safety alert symbol shall not be used with this type of safety message.</p> <p>Failure to follow these instructions can result in equipment damage.</p>

Please Note

Electrical equipment should only be installed, operated, serviced, and maintained by qualified personnel. No responsibility is assumed by Schneider Electric for any consequences arising out of the use of this material.

A qualified person is one who has skills and knowledge related to the construction, installation, and operation of electrical equipment and has received safety training to recognize and avoid the hazards involved.

Safety Precautions

⚠ DANGER

HAZARD OF ELECTRIC SHOCK, EXPLOSION, OR ARC FLASH

All safety instructions in this document must be read, understood and followed.

Failure to follow these instructions will result in death or serious injury.

⚠ DANGER

HAZARD OF ELECTRIC SHOCK, EXPLOSION, OR ARC FLASH

Read all instructions in the Installation Manual before installing or working on this UPS system.

Failure to follow these instructions will result in death or serious injury.

⚠ DANGER

HAZARD OF ELECTRIC SHOCK, EXPLOSION, OR ARC FLASH

Do not install the UPS system until all construction work has been completed and the installation room has been cleaned.

Failure to follow these instructions will result in death or serious injury.

⚠ DANGER

HAZARD OF ELECTRIC SHOCK, EXPLOSION, OR ARC FLASH

- The product must be installed according to the specifications and requirements as defined by Schneider Electric. It concerns in particular the external and internal protections (upstream breakers, battery breakers, cabling, etc.) and environmental requirements. No responsibility is assumed by Schneider Electric if these requirements are not respected.
- After the UPS system has been electrically wired, do not start up the system. Startup must only be performed by Schneider Electric.

Failure to follow these instructions will result in death or serious injury.

⚠ DANGER

HAZARD OF ELECTRIC SHOCK, EXPLOSION, OR ARC FLASH

The UPS System must be installed according to local and national regulations. Install the UPS according to:

- IEC 60364 (including 60364–4–41 - protection against electric shock, 60364–4–42 - protection against thermal effect, and 60364–4–43 - protection against overcurrent), **or**
- NEC NFPA 70, **or**
- Canadian Electrical Code (C22.1, Part 1)

depending on which one of the standards apply in your local area.

Failure to follow these instructions will result in death or serious injury.

⚠ DANGER

HAZARD OF ELECTRIC SHOCK, EXPLOSION, OR ARC FLASH

- Install the UPS system in a temperature controlled indoor environment free of conductive contaminants and humidity.
- Install the UPS system on a non-flammable, level and solid surface (e.g. concrete) that can support the weight of the system.

Failure to follow these instructions will result in death or serious injury.

⚠ DANGER

HAZARD OF ELECTRIC SHOCK, EXPLOSION, OR ARC FLASH

The UPS is not designed for and must therefore not be installed in the following unusual operating environments:

- Damaging fumes
- Explosive mixtures of dust or gases, corrosive gases, or conductive or radiant heat from other sources
- Moisture, abrasive dust, steam or in an excessively damp environment
- Fungus, insects, vermin
- Salt-laden air or contaminated cooling refrigerant
- Pollution degree higher than 2 according to IEC 60664-1
- Exposure to abnormal vibrations, shocks, and tilting
- Exposure to direct sunlight, heat sources, or strong electromagnetic fields

Failure to follow these instructions will result in death or serious injury.

⚠ DANGER

HAZARD OF ELECTRIC SHOCK, EXPLOSION, OR ARC FLASH

Do not drill or cut holes for cables or conduits with the gland plates installed and do not drill or cut holes in close proximity to the UPS.

Failure to follow these instructions will result in death or serious injury.

⚠ WARNING

HAZARD OF ARC FLASH

Do not make mechanical changes to the product (including removal of cabinet parts or drilling/cutting of holes) that are not described in the Installation Manual.

Failure to follow these instructions can result in death, serious injury, or equipment damage.

⚠ WARNING

HAZARD OF OVERHEATING

Respect the space requirements around the UPS system and do not cover the product’s ventilation openings when the UPS system is in operation.

Failure to follow these instructions can result in death, serious injury, or equipment damage.

⚠ WARNING**HAZARD OF EQUIPMENT DAMAGE**

Do not connect the UPS output to regenerative load systems including photovoltaic systems and speed drives.

Failure to follow these instructions can result in death, serious injury, or equipment damage.

Electrical Safety**⚠ DANGER****HAZARD OF ELECTRIC SHOCK, EXPLOSION OR ARC FLASH**

- Electrical equipment must be installed, operated, serviced, and maintained only by qualified personnel.
- The UPS system must be installed in a room with restricted access (qualified personnel only).
- Apply appropriate personal protective equipment (PPE) and follow safe electrical work practices.
- Turn off all power supplying the UPS system before working on or inside the equipment.
- Before working on the UPS system, check for hazardous voltage between all terminals including the protective earth.
- The UPS contains an internal energy source. Hazardous voltage can be present even when disconnected from the utility/mains supply. Before installing or servicing the UPS system, ensure that the units are OFF and that utility/mains and batteries are disconnected. Wait five minutes before opening the UPS to allow the capacitors to discharge.
- A disconnection device (e.g. disconnection circuit breaker or switch) must be installed to enable isolation of the system from upstream power sources in accordance with local regulations. This disconnection device must be easily accessible and visible.
- The UPS must be properly earthed/grounded and due to a high leakage current, the earthing/grounding conductor must be connected first.

Failure to follow these instructions will result in death or serious injury.

⚠ DANGER**HAZARD OF ELECTRIC SHOCK, EXPLOSION, OR ARC FLASH**

In systems where backfeed protection is not part of the standard design, an automatic isolation device (backfeed protection option or other device meeting the requirements of IEC/EN 62040–1 or UL 1778 4th Edition – depending on which of the two standards apply to your local area) must be installed to prevent hazardous voltage or energy at the input terminals of the isolation device. The device must open within 15 seconds after the upstream power supply fails and must be rated according to the specifications.

Failure to follow these instructions will result in death or serious injury.

When the UPS input is connected through external isolators that, when opened, isolate the neutral or when the automatic backfeed isolation is provided external to the equipment or is connected to an IT power distribution system, a label must be fitted at the UPS input terminals, and on all primary power isolators installed remote from the UPS area and on external access points between such isolators and the UPS, by the user, displaying the following text (or equivalent in a language which is acceptable in the country in which the UPS system is installed):

⚠ DANGER**HAZARD OF ELECTRIC SHOCK, EXPLOSION, OR ARC FLASH**

Risk of Voltage Backfeed. Before working on this circuit: Isolate the UPS and check for hazardous voltage between all terminals including the protective earth.

Failure to follow these instructions will result in death or serious injury.

Battery Safety**⚠ DANGER****HAZARD OF ELECTRIC SHOCK, EXPLOSION, OR ARC FLASH**

- Battery circuit breakers must be installed according to the specifications and requirements as defined by Schneider Electric.
- Servicing of batteries must only be performed or supervised by qualified personnel knowledgeable of batteries and the required precautions. Keep unqualified personnel away from batteries.
- Disconnect charging source prior to connecting or disconnecting battery terminals.
- Do not dispose of batteries in a fire as they can explode.
- Do not open, alter, or mutilate batteries. Released electrolyte is harmful to the skin and eyes. It may be toxic.

Failure to follow these instructions will result in death or serious injury.

⚠ DANGER**HAZARD OF ELECTRIC SHOCK, EXPLOSION, OR ARC FLASH**

Batteries can present a risk of electric shock and high short-circuit current. The following precautions must be observed when working on batteries

- Remove watches, rings, or other metal objects.
- Use tools with insulated handles.
- Wear protective glasses, gloves and boots.
- Do not lay tools or metal parts on top of batteries.
- Disconnect the charging source prior to connecting or disconnecting battery terminals.
- Determine if the battery is inadvertently grounded. If inadvertently grounded, remove source from ground. Contact with any part of a grounded battery can result in electric shock. The likelihood of such shock can be reduced if such grounds are removed during installation and maintenance (applicable to equipment and remote battery supplies not having a grounded supply circuit).

Failure to follow these instructions will result in death or serious injury.

⚠ DANGER**HAZARD OF ELECTRIC SHOCK, EXPLOSION, OR ARC FLASH**

When replacing batteries, always replace with the same type and number of batteries or battery packs.

Failure to follow these instructions will result in death or serious injury.

⚠ CAUTION

RISK OF EQUIPMENT DAMAGE

- Wait until the system is ready to be powered up before installing batteries in the system. The time duration from battery installation until the UPS system is powered up must not exceed 72 hours or 3 days.
- Batteries must not be stored more than six months due to the requirement of recharging. If the UPS system remains de-energized for a long period, we recommend that you energize the UPS system for a period of 24 hours at least once every month. This charges the batteries, thus avoiding irreversible damage.

Failure to follow these instructions can result in injury or equipment damage.

Product Specific Safety Information

⚠ DANGER

HAZARD OF ELECTRICAL SHOCK, EXPLOSION OR ARC FLASH

The UPS system has no built-in disconnection devices for AC output and DC input. An AC output overcurrent protection and AC output disconnect must be provided by the customer.

Failure to follow these instructions will result in death or serious injury.

⚠ DANGER

HAZARD OF ELECTRICAL SHOCK, EXPLOSION OR ARC FLASH

For customer-supplied external batteries, overcurrent protection and a disconnection device for the battery circuits must be provided.

Failure to follow these instructions will result in death or serious injury.

Specifications

AC Input Specifications

NOTE: All current values are based on a 40 kW maximum configuration.

Connection type	3PH + N + PE
Input voltage (V)	3–Phase 208 V (166 V - 240 V)
Input frequency (Hz)	40–70
THDI	< 6% at full load
Nominal input current (A)	123
Maximum input current – continuous, at minimum mains voltage (A)	154
Input current protection (external to UPS, not supplied) ¹	175
Maximum Short Circuit Withstand (kA)	30

⚠ DANGER

HAZARD OF ELECTRIC SHOCK, EXPLOSION, OR ARC FLASH

If your installation does not include an Isolation Transformer and a maintenance bypass enclosure (optional equipment), use a 175 Amp Class “J” current limiting fuse on each input phase.

Failure to follow these instructions will result in death or serious injury.

AC Bypass Input Specifications

Connection type	3PH + N + PE
Input frequency (Hz)	40 – 70
Nominal input current (A)	111

AC Output Specifications

Output voltage	208 V
Connection type	3PH + N + PE
Overload capacity	150% for 30 seconds (normal operation) 150% for 30 seconds (battery operation) 100% continuous (bypass operation) 1000% for 500 ms (bypass operation)
Nominal output current (A)	111
Maximum output current (in bypass only at 125% overload, per phase) (A)	139
Neutral output current with 100% switch mode load (A) ²	192
Output current protection – external to UPS, not supplied (A) ³	150

1. Input: 175 Amp. 3-Pole AC circuit breaker with 30 kAIC.
2. Neutral output wires: rate for 173% of output phase current if feeding all Switch Mode Power Supply loads without power factor correction.
3. Output: 150 Amp 3-pole AC circuit breaker with 30 kAIC.

Output frequency (on line, in bypass) ⁴	Synchronized to input over the range 57 Hz – 63 Hz
Output frequency (on battery) (Hz)	50/60
Slew rate (Hz/s)	Programmable to 0.25, 0.5, 1, 2, 4, and 6
THDU	< 2% linear < 5% non-linear

Battery Specifications

Type	VRLA
Nominal voltage (VDC)	+/- 192 (96 cells at 2 V)
Float voltage (VDC)	+/- 219 (96 cells at 2 .28 V) ⁵
End of discharge voltage at full load (VDC) ⁶	+/- 158 (96 cells at 1.65 V)
Maximum charging power	4 kW (5 kW if redundant Power Module is present) ⁷
Typical recharge time (to 80% of capacity)	3.5 hours

Heat Dissipation

	Symmetra PX 10 kW Scalable to 40 kW	Symmetra PX 20 kW Scalable to 40 kW	Symmetra PX 30 kW Scalable to 40 kW	Symmetra PX 40 kW Scalable to 40 kW
Heat dissipation (BTU/hr)	2160	4147	6134	8121

Recommended Cable Sizes

NOTE: All wiring must comply with all national and/or local electrical code.

NOTE: The recommended cable sizes are based in an environment with an ambient temperature of 40°C (104°F)

NOTE: Neutral output cables: rate for 173% of output phase current if feeding all Switch Mode Power Supply loads without power factor correction.

NOTE: PE cables: sized in accordance with NEC Article 250-122 and Table 250-122.

NOTE: Maximum cable sizes: 250 kcmil.

Input cable	2/0 AWG 90 °C (194°F) rated copper wire.
Output cable	1/0 AWG 90 °C (194°F) rated copper wire

Recommended Cable Lugs and Crimping Tool

Recommended cable lugs and crimping tools. Manufacturer: Framatome Connectors International (FCI).

4. The following ranges can be selected: 40-60 Hz, 47-53 Hz, 49.9-50.1 Hz, 50-70 Hz, 57-63 Hz, and 59.9–60.1 Hz
5. Float voltage is temperature compensated. It is decreased 320 mV per °C for temperatures higher than 20 °C
6. May be higher at less than full load
7. It may drop to lower values at low AC Mains.

Cable Size (AWG)	Terminal bolt diameter: 8 mm		
	Cable Lug Type	Crimping Tool	Die
8	YA8CL2TC38	MD7-34R	W8CVT
6	YA6CL2TC38	MD7-34R	W5CVT
4	YA4CL2TC38	MD7-34R	W4CVT
3	YA3CL2TC38	Y35	U3CRT
2	YA2CL2TC38	MD7-34R	W2CVT
1	YA1CL2TC38	MD7-34R	W1CVT
1/0	YA25CL2TC38	MD7-34R	W25VT
2/0	YA26CL2TC38	MD7-34R	W26VT
3/0	YA27CL2TC38	MD7-34R	W27VT
4/0	YA28CL2TC38	MD7-34R	W28VT

Overcurrent Protective Devices in Single Systems

	Symmetra PX 40 kW
Utility/mains input	175 Amp 3-Pole AC circuit breaker with 30 kAIC ⁸
Output	150 Amp 3-pole AC circuit breaker with 30 kAIC

8. If your installation does not include an isolation transformer and a maintenance bypass enclosure (option), use a 175 Amp class “J” current limiting fuse on each input phase.

Mechanical Assembly

1. Prepare UPS and modular battery cabinets (if present) for cables by following *Prepare for Cables*, page 14.
2. *Connect the Power Cables*, page 18.
3. *Connect the EPO*, page 20.
4. *Connect Communication Cables*, page 23.
5. **In installations with modular battery cabinet(s):** *Install Modular Battery Cabinet (Option)*, page 26.
6. *Install Maintenance Bypass Enclosure (Option)*, page 29.
7. Level all cabinets with the leveling feet and a bubble level.

Prepare for Cables

Prepare for Cables in a Bottom Cable Entry System

1. Loosen the screws to remove the plate.
2. Punch holes as required and reinstall the plate before mounting the wiring hardware.

Rear View

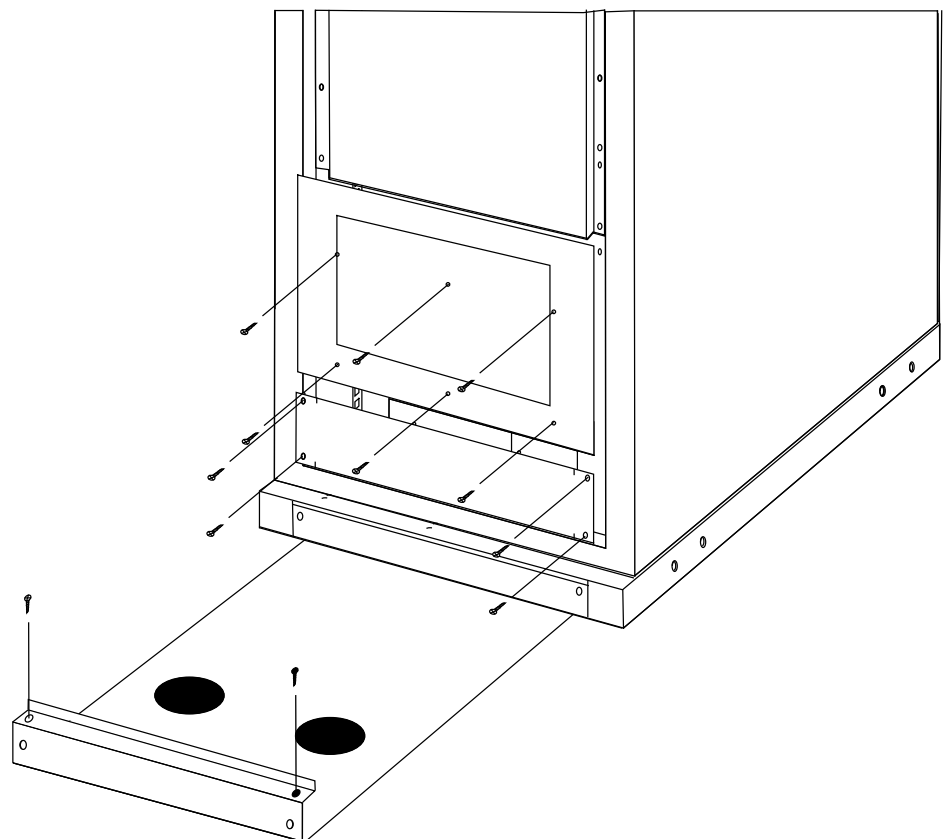

Prepare for Cables in a Rear Cable Entry System

1. Loosen the screws to remove the plate.

- Punch holes as required and reinstall the plate before mounting the wiring hardware.

Rear View of UPS

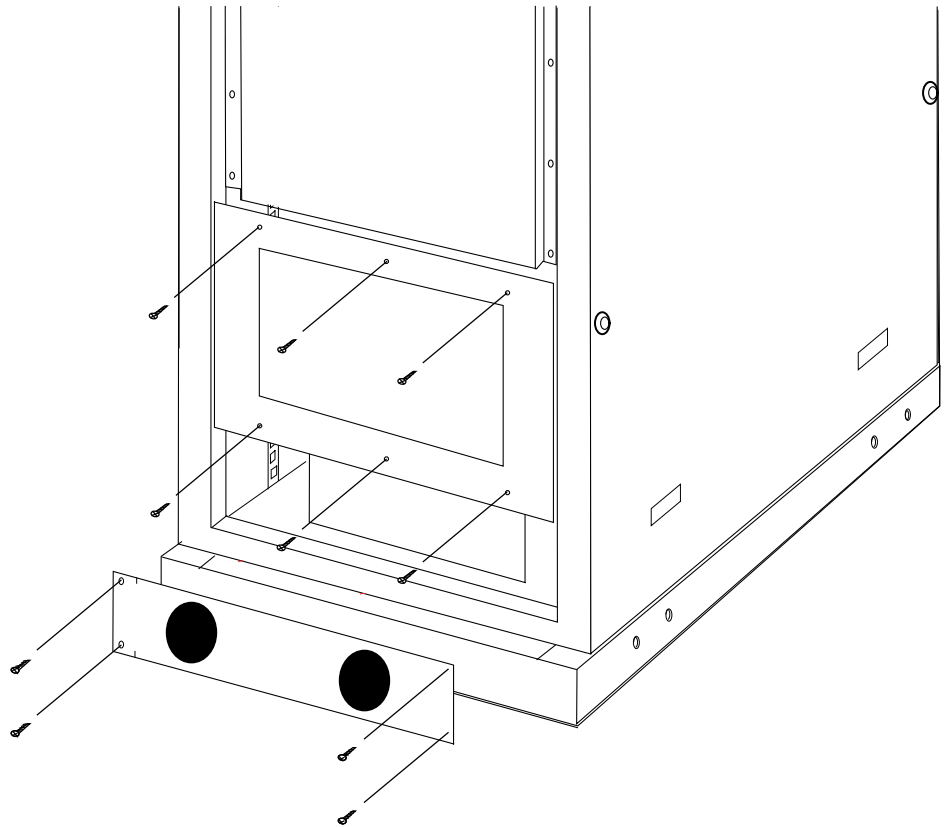

Rearrange Side Panels for Line-Up and Match Modular Battery Cabinets

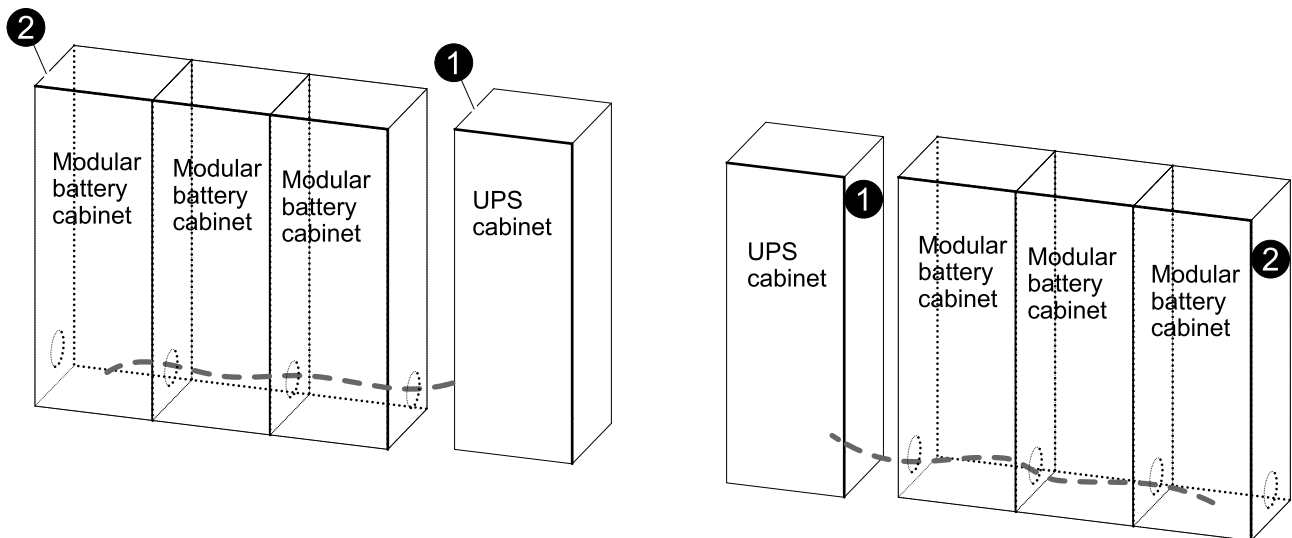

⚠ DANGER

HAZARD OF ELECTRIC SHOCK, EXPLOSION OR ARC FLASH

Remove and reinstall the PE cable connected to the cabinet side panels when rearranging the side panels. Use a 13 mm wrench.

Failure to follow these instructions will result in death or serious injury.

- Remove the solid side panel on the UPS cabinet on the side facing towards the line-up and match modular cabinet(s).

- Remove the side panel with knockouts on the modular battery cabinet facing away from the UPS/other modular battery cabinet(s).

Removal of the Side Panel

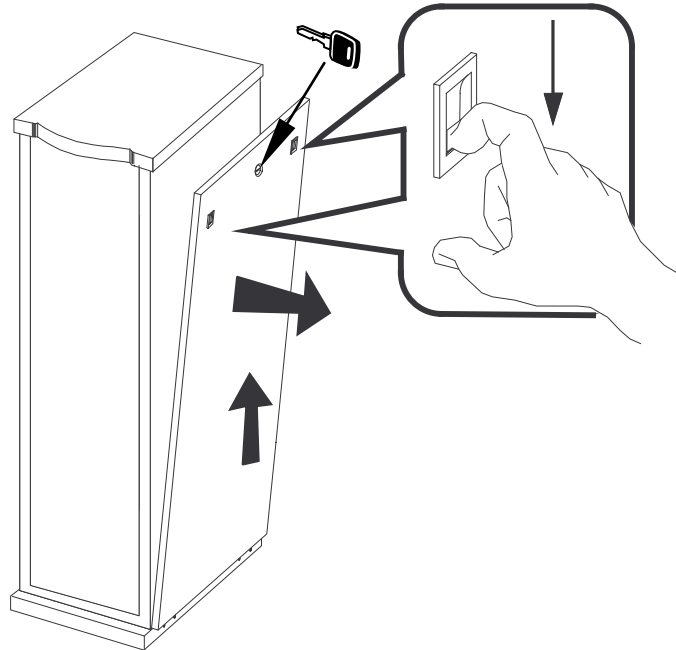

- Install the solid side panel on the modular battery cabinet.
- Remove the needed knockouts on the side panel with knockouts and install the cable routing hardware (chase nipple, locking nut and cable bushing) and install it on the UPS cabinet.
- Remove the side panels on the other modular battery cabinets, remove the needed knockouts, install the cable routing hardware and reinstall the side panels. Use the stabilizing feet to adjust for aligning the cabinets, if necessary

Communication cables and battery cables can now be routed through the knockouts in the modular battery cabinets.

Level the Cabinets

⚠ WARNING

TIP HAZARD

The system must be installed on a level floor. The leveling feet will stabilize the cabinet, but will not compensate for a badly sloped floor.

Failure to follow these instructions can result in death, serious injury, or equipment damage.

1. Use a screwdriver to lower the four leveling feet

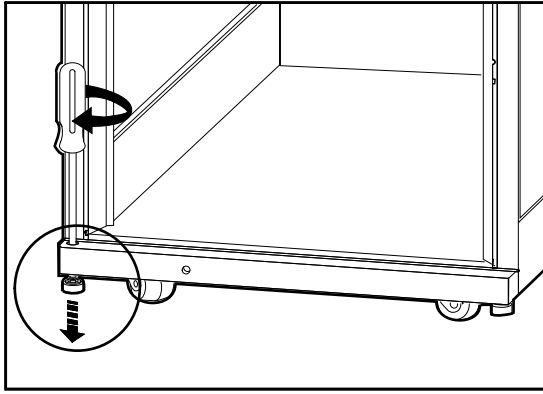

2. Use a wrench to adjust the four leveling feet and ensure that the cabinet is level.

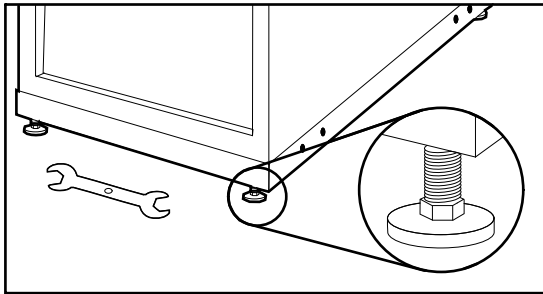

▲ WARNING

TIP HAZARD

Do not move the cabinet after the leveling feet have been lowered.

Failure to follow these instructions can result in death, serious injury, or equipment damage.

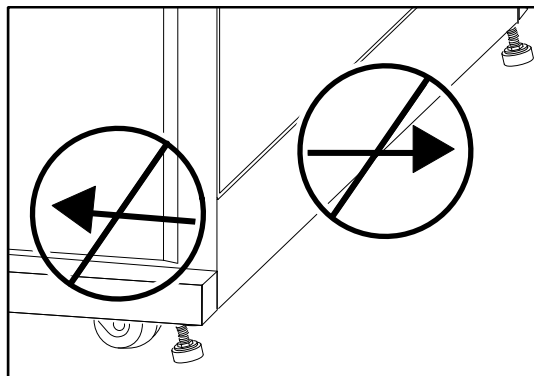

Connect the Power Cables

⚠ DANGER

HAZARD OF ELECTRIC SHOCK, EXPLOSION OR ARC FLASH

Ensure clockwise phase rotation and neutral location.

Failure to follow these instructions will result in death or serious injury.

⚠ DANGER

HAZARD OF ELECTRIC SHOCK, EXPLOSION OR ARC FLASH

Power terminal lug diameter is 8 mm and torque value is 6 Nm.

Failure to follow these instructions will result in death or serious injury.

1. Route the cables as shown on the drawing. Input and output cables must be run in separate conduits.
2. Connect the input cables (L1, L2, L3, N) to the input terminals.
3. Connect the output cables (L1, L2, L3, N) to the output terminals.
4. **For installations with modular battery cabinets:** Connect the battery cables (+, CT and –) to the DC input terminals in the UPS cabinet and route them to the modular battery cabinet through the side, rear or bottom depending on chosen cable entry.

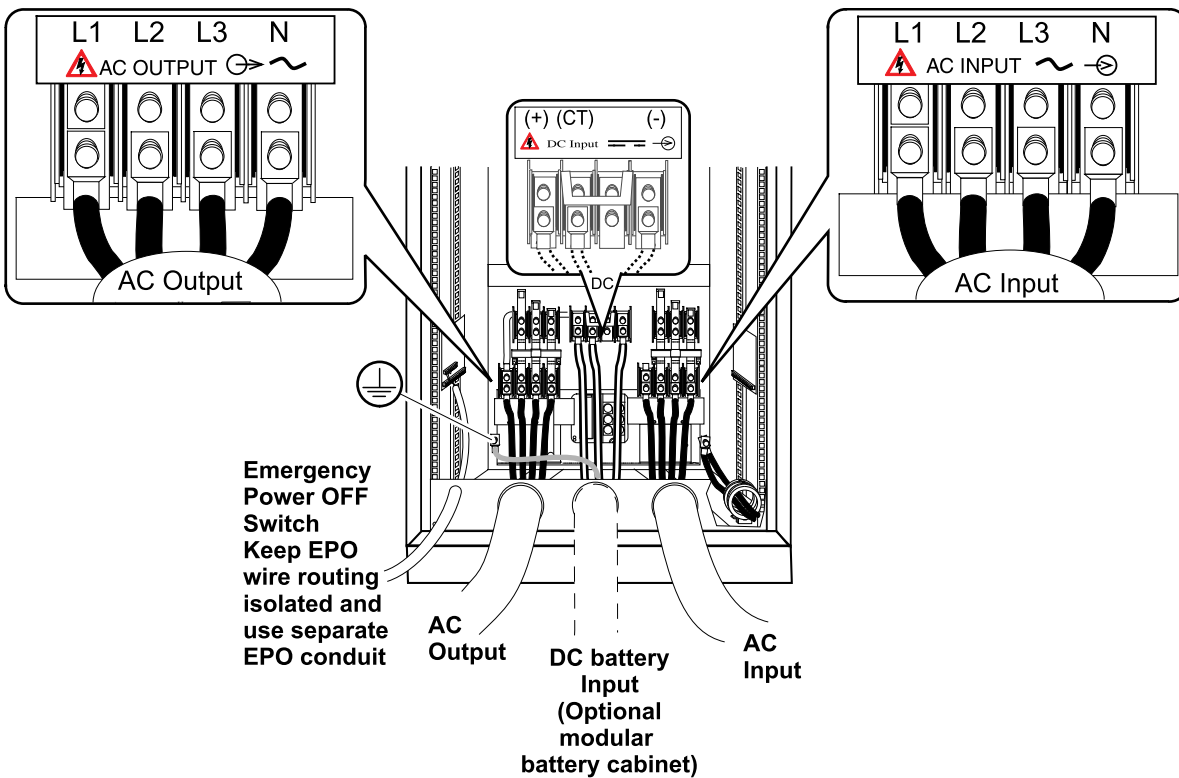

5. Connect the PE cable.

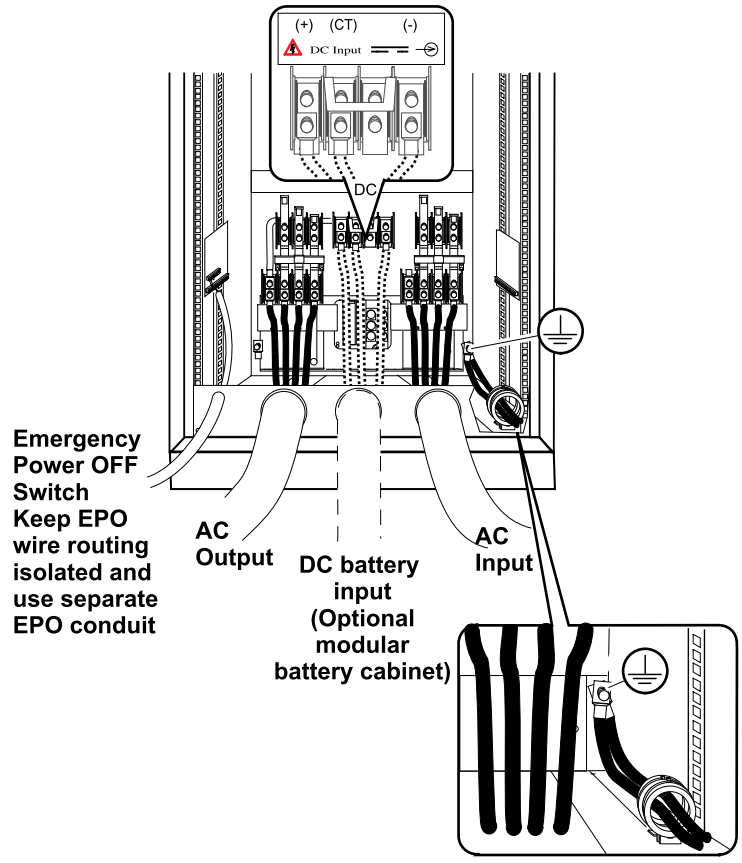

Connect the EPO

The UPS must be connected to either a dry contact or a 24 VDC Emergency Power Off (EPO) switch.

The EPO circuit is considered a Class 2 and SELV (Safety Extra Low Voltage). A SELV circuit is isolated from primary circuitry through an isolating transformer and designed so that under normal conditions, the voltage is limited to 42.4 VAC peak or 60 VDC. SELV and Class 2 circuits must be isolated from all primary circuitry. Do not connect any circuit to the EPO terminal block unless it can be confirmed that the circuit is SELV or Class 2.

For installations in the US:

- CL2 Class 2 cable for general purpose use
- CL2P Plenum cable for use in vertical shaft or from floor to floor
- CL2R Racer cable for use in dwellings and raceways
- CL2X Limited use cable for dwellings and raceways

For installation in Canada:

- CL2R-Certified, type ELC (Extra-Low-Voltage Control Cable)
- CL2X-Certified, type ELC (Extra-Low-Voltage Control Cable)

1. Route the EPO cable through a separate conduit in the rear of the cabinet and keep the EPO wire routing isolated from the power cables.

2. Connect a normally open (NO) or a normally closed (NC) EPO switch to the board in the UPS.

Rear view of UPS cabinet

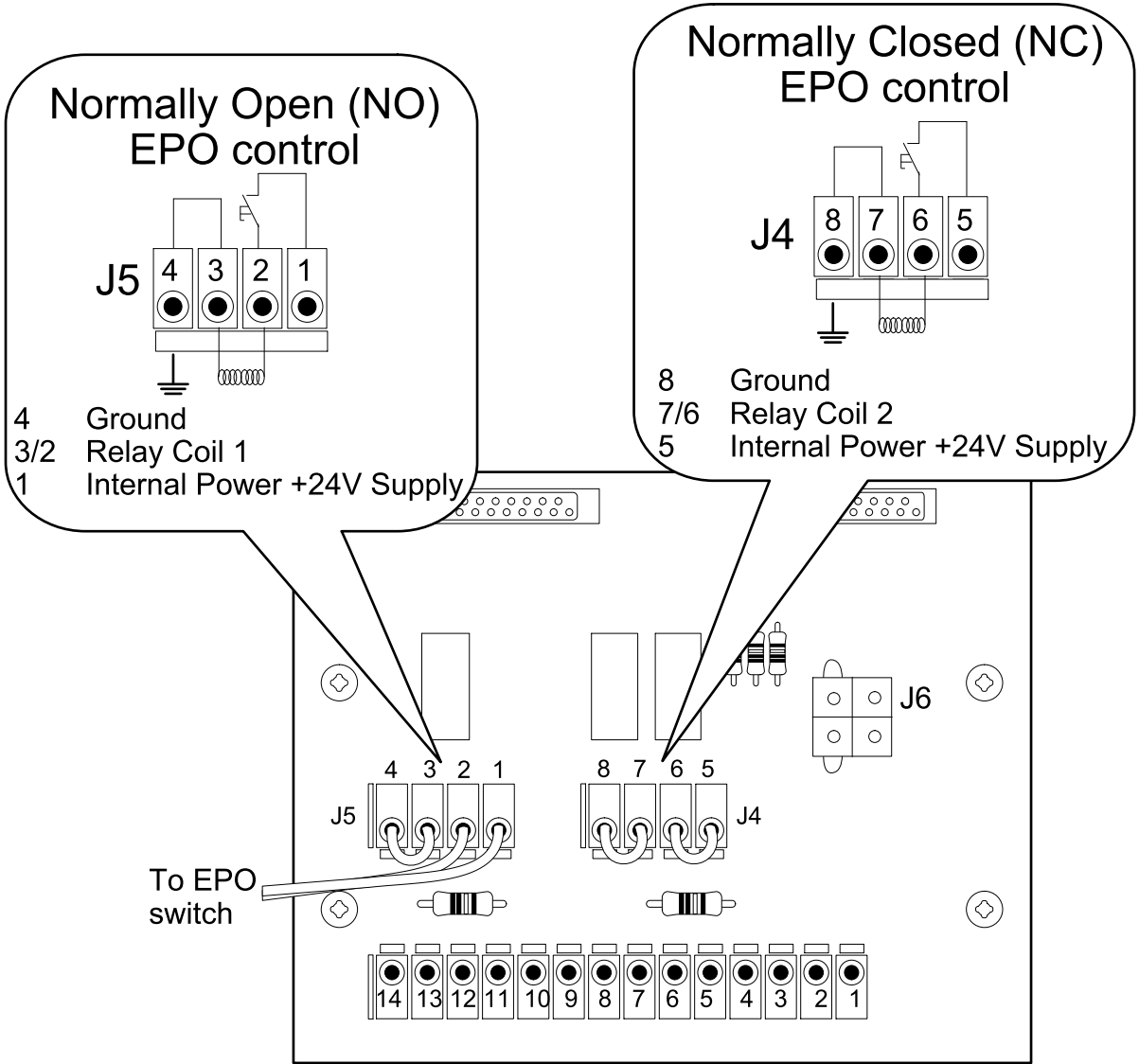
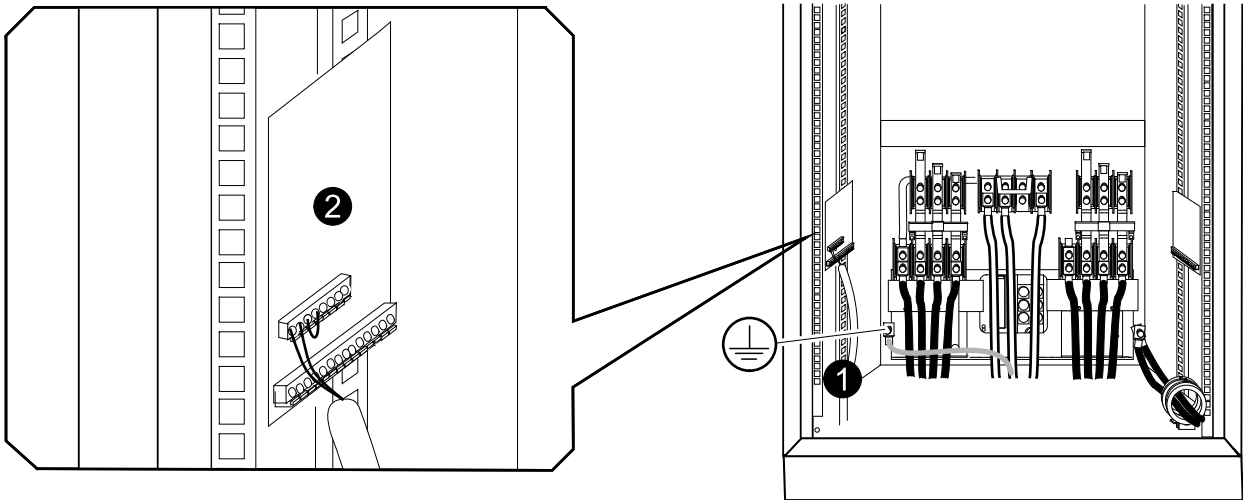

EPO Wiring Options

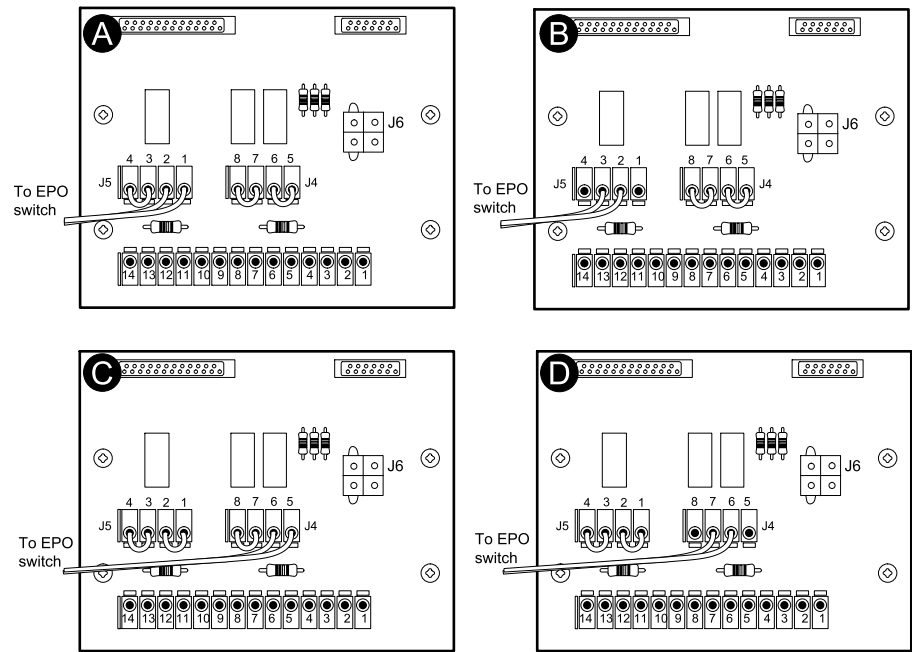

- A. Dry Normally Open contacts
- B. +24V Normally Open (remove jumper)
- C. Dry Normally Closed contacts (remove jumper)
- D. +24V Normally Closed (remove jumper)

Connect Communication Cables

⚠ DANGER

HAZARD OF ELECTRIC SHOCK, EXPLOSION OR ARC FLASH

Ensure total power off before removing the side panel.

Failure to follow these instructions will result in death or serious injury.

NOTE: Use 20-foot standard Cat data cable (supplied). If the cable length is inadequate, a longer Cat 5 cable, or couplers, can be used (not supplied).

NOTE: If bottom cable entry is required, follow steps 1 to 5 below to gain access to the communication cables. If not, proceed to step 6.

Front View of UPS

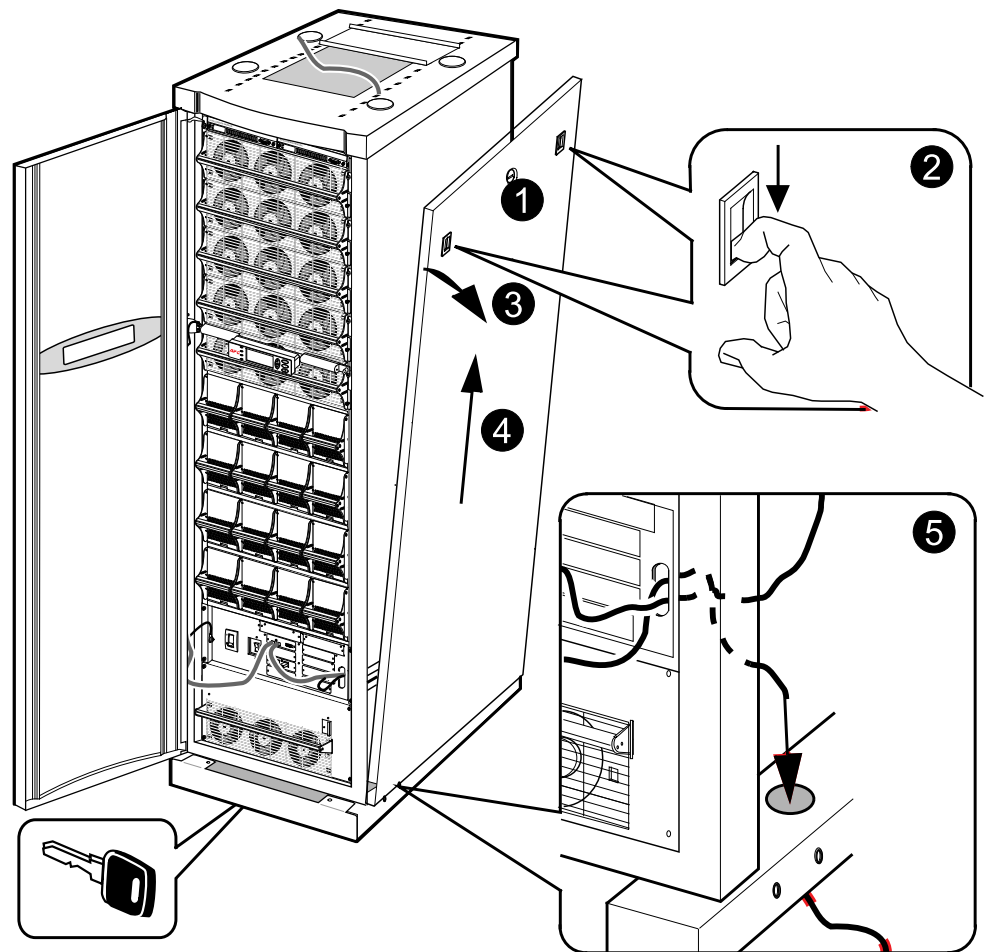

1. Unlock the right-side panel using the key.
2. Depress the latches.
3. Pull out the panel.
4. Lift the panel at an angle away from the cabinet.
5. Route the communication cables through the front holes of the cabinets. Exit the cabinets from the bottom or top as required.

6. Connect the network communication cable.

Front View of UPS

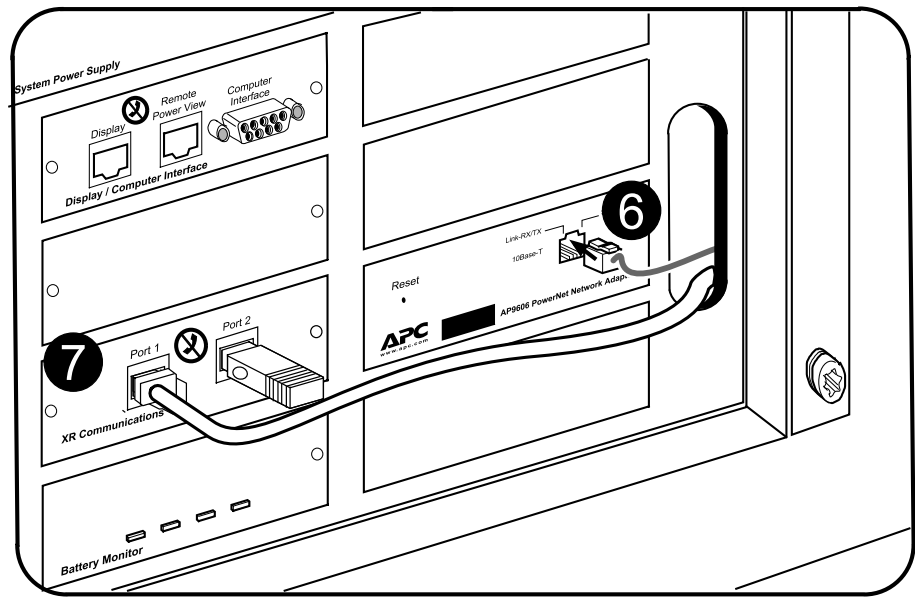

- 7. Only in installations with modular battery cabinets:** Route the communication cable from XR Communications port 2 in the first modular battery cabinet to the UPS XR Communications port 1 (for remote modular battery cabinets the length of the signal must not exceed 50 m). The side panel of the modular battery cabinet is removed for cable wiring as in steps 1–5.

Front View of Modular Battery Cabinet

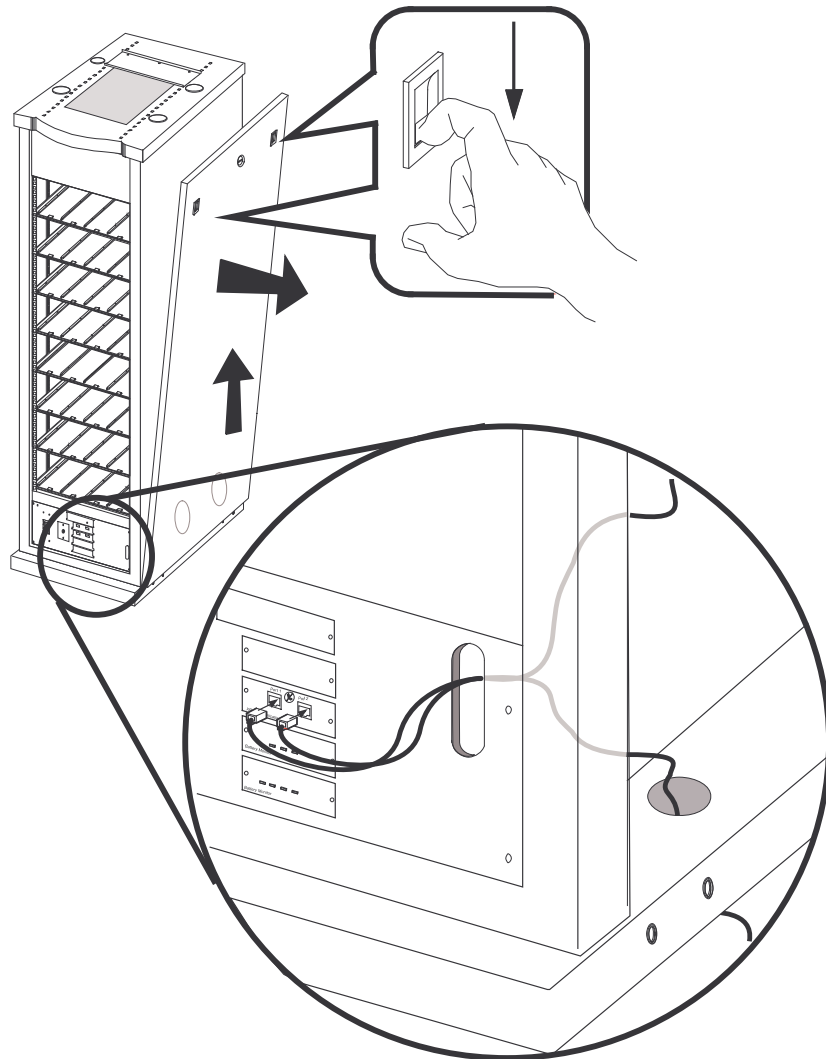

- 8. Only in installations with modular battery cabinets:** Route the communication cable from XR Communications port 1 in each modular battery cabinet to XR Communications port 2 in the next modular battery cabinet. Remove the terminator when necessary. Insert the terminator from the cable into the unused communication port on the last modular battery cabinet.
- 9.** Reinstall and lock the side panels on the cabinets after finishing cable routing.

Install Modular Battery Cabinet (Option)

Connect Battery Cables in Modular Battery Cabinet

NOTE: Power terminal lug diameter: 8 mm. Torque power terminal lugs to 53 lb-in (6 Nm).

NOTE: PE and power cables provided with the modular battery cabinet are only for internal cable routing through the side panels — not for cable routing through external conduits.

1. Connect the modular battery cabinet to the PE stud in the UPS cabinet.
2. Connect the battery cables (+, - and CT) from the UPS to the DC output terminals in the modular battery cabinet.

Modular Battery Cabinet

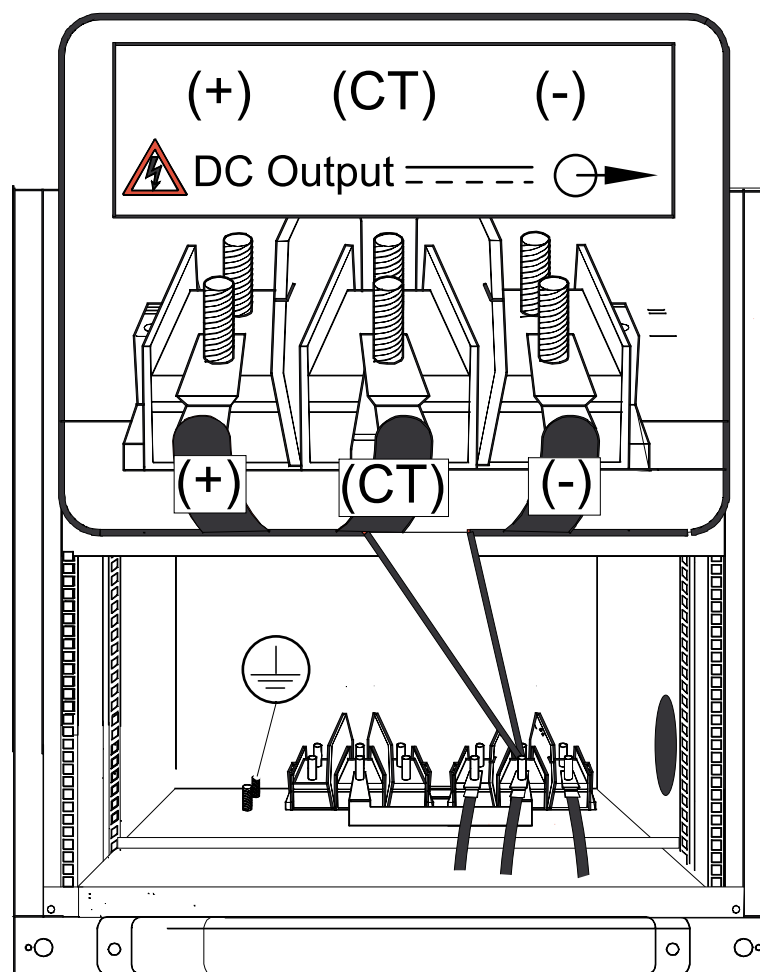

Connect the Battery Cables between the Modular Battery Cabinets

NOTE: For remote modular battery cabinets, the length of the signal and power cables must not exceed 50 m for the cable that connects the modular battery cabinet to the UPS.

1. Connect the battery cables from the DC output terminals in modular battery cabinet 2 to the DC input terminals in modular battery cabinet 1.

Modular Battery Cabinet 1

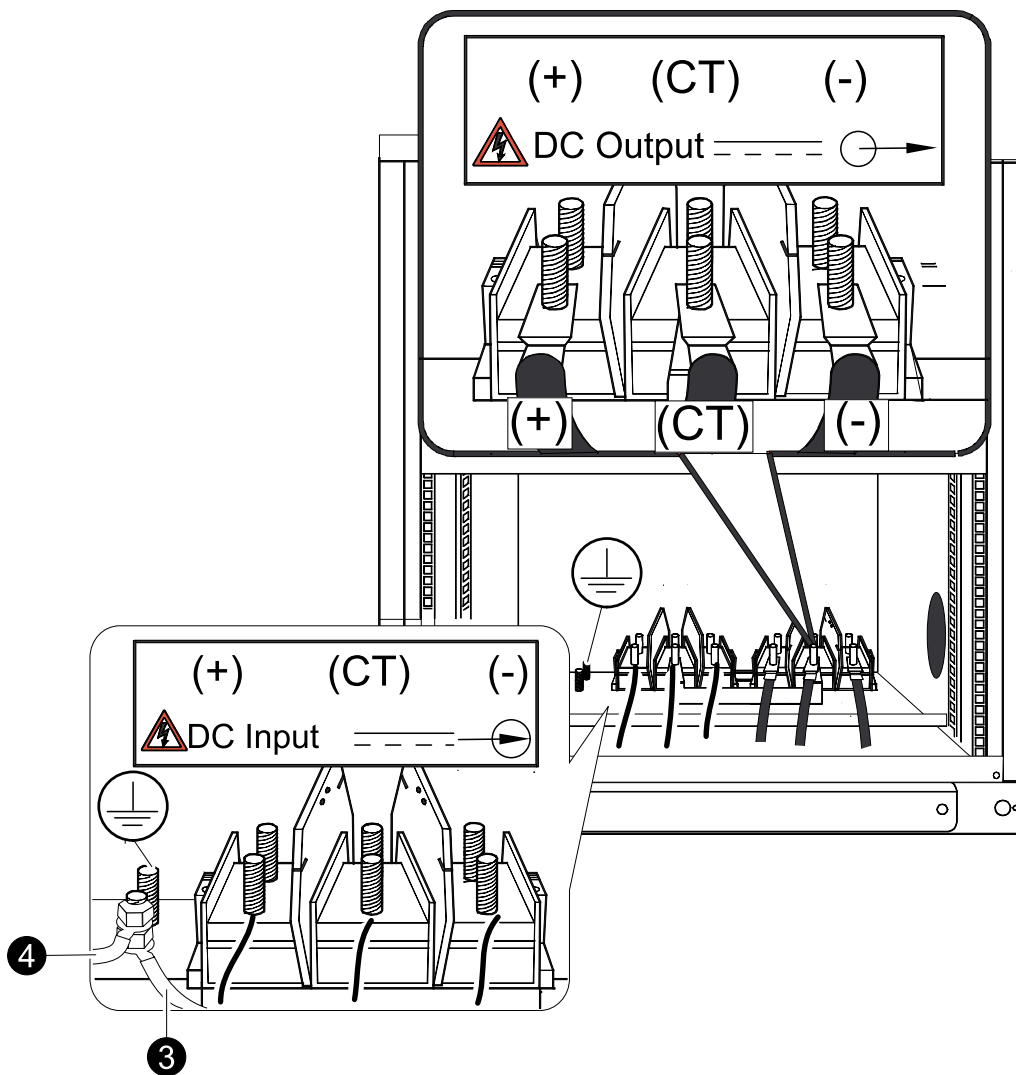

2. Repeat for modular battery cabinet 3 and 4, if applicable.
3. Connect the PE cable from the UPS to the modular battery cabinet (closest to the UPS).

- Route the PE cable from modular battery cabinet to modular battery cabinet through the bottom, rear or side depending on chosen cable entry.

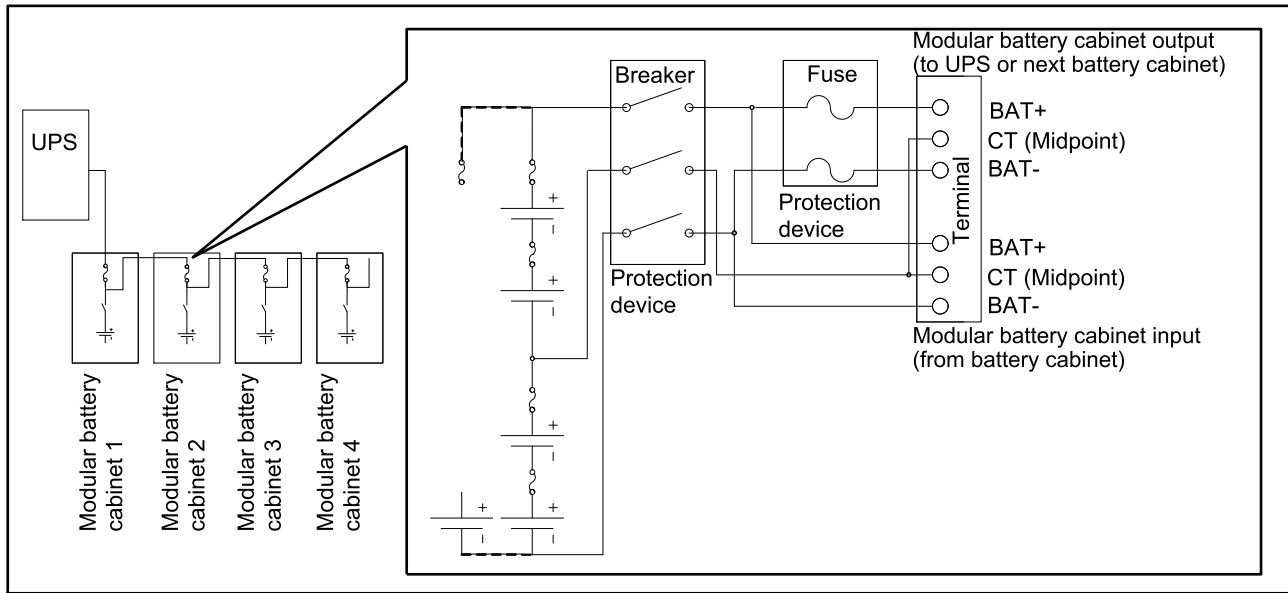

Fuse rating	125 A Class J
Breaker rating	320 A with thermal and magnetic trip-unit

- Place the cabinet address on the front of each modular battery cabinet (**1** for modular battery cabinet 1, **2** for modular battery cabinet number 2 etc.).

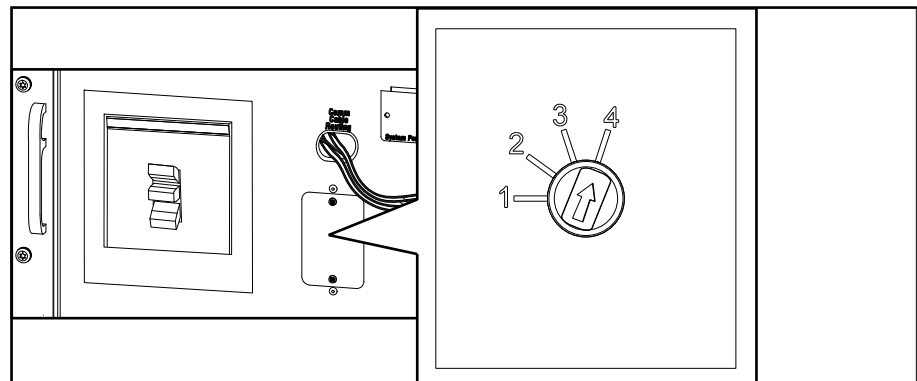

Install Maintenance Bypass Enclosure (Option)

1. Mount the maintenance bypass enclosure on a wall close to the UPS.
2. Connect cables from the utility/mains to the utility input terminals in the maintenance bypass enclosure.
3. Connect cables from the UPS AC input to the input terminals on the maintenance bypass enclosure.
4. Connect cables from the UPS AC output to the output terminals on the maintenance bypass enclosure.
5. Connect cables from the output terminals on the maintenance bypass enclosure to the load equipment/distribution.
6. Connect control wires between the UPS and the maintenance bypass enclosure.

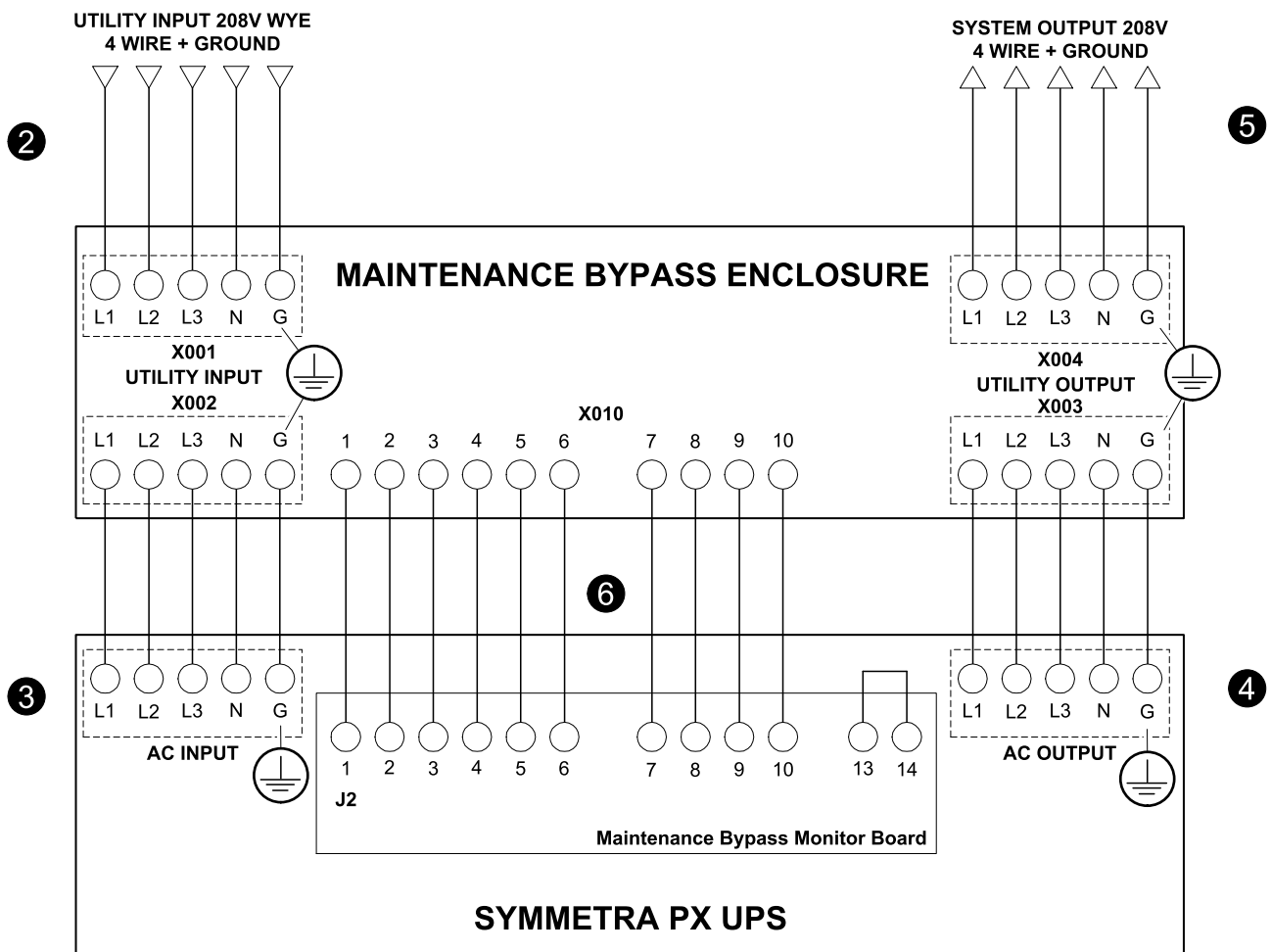

Schneider Electric
35 rue Joseph Monier
92500 Rueil Malmason
France

+ 33 (0) 1 41 29 70 00

www.schneider-electric.com

As standards, specifications, and design change from time to time,
please ask for confirmation of the information given in this publication.

© 2013 – 2016 Schneider Electric. All rights reserved.

990–4063H-001