

User's Guide



Packard Bell EasyNote TS

TABLE OF CONTENTS

| | | | |
|---|-----------|--|-----------|
| Starting your computer | 4 | Optimizing battery life..... | 35 |
| Wireless connection..... | 4 | Battery-low warning..... | 35 |
| Registration..... | 5 | Software | 37 |
| Software installation..... | 6 | Using Windows and your software..... | 37 |
| Recovery..... | 6 | Welcome Center..... | 37 |
| Having trouble?..... | 6 | Internet security offer..... | 38 |
| Computer Basics | 8 | Productivity software..... | 38 |
| Safety and comfort..... | 8 | Packard Bell Recovery Management..... | 38 |
| Safety precautions..... | 8 | Packard Bell Updater..... | 39 |
| Health precautions..... | 11 | Playing multimedia files..... | 40 |
| Getting to know your computer | 13 | Playing DVD movies..... | 43 |
| Top view - display..... | 14 | Social networks (optional)..... | 45 |
| Top view - keyboard..... | 15 | Internet | 50 |
| Special keys..... | 17 | First steps on the net..... | 50 |
| Front view..... | 20 | Protecting your computer..... | 50 |
| Rear view..... | 20 | Choose an Internet Service Provider..... | 50 |
| Left view..... | 21 | Network connections..... | 52 |
| Right view..... | 22 | Surf the Net!..... | 55 |
| Base view..... | 24 | Security..... | 57 |
| Upgrading your computer | 25 | Helpdesk | 71 |
| Expanding through options..... | 25 | Safe computing..... | 71 |
| Connectivity options..... | 25 | Maintenance..... | 71 |
| Power supply | 30 | Updates..... | 78 |
| AC power adapter..... | 30 | Windows Remote Assistance..... | 80 |
| Battery pack..... | 31 | Recovery | 81 |
| Battery pack characteristics..... | 31 | Packard Bell Recovery Management..... | 81 |
| Installing or removing the battery pack..... | 33 | Creating recovery discs..... | 81 |
| Charging the battery..... | 34 | Recovering your system..... | 85 |
| Checking the battery level..... | 35 | Types of recovery..... | 86 |

| | |
|-------------------------------|------------|
| Regulatory information | 92 |
| Environment | 97 |
| Software license | 99 |
| Index | 102 |

Copyright © 2010.
All Rights Reserved.

Packard Bell EasyNote TS User Guide
Original Issue: 26 November 2010

Visit **registration.packardbell.com** and discover the benefits of being a customer of Packard Bell.

Remark: All images are for reference purposes only. Actual configuration may vary.

STARTING YOUR COMPUTER

Thank you for purchasing this Packard Bell computer!

This guide has been designed to introduce you to the features of your computer and assist in your computing experience.

After setting up and starting your computer, as shown in the setup instructions, it will ask you questions that will help you connect to the Internet. Your computer will then configure installed software.

WIRELESS CONNECTION

To connect to a wireless network, first check the wireless features of your computer are on, and that the router or modem you want to connect to is also correctly configured.

- If wireless is not on, press the communication key () to open the *Launch Manager* and make sure Wi-Fi is **On**.
- Your computer will detect and display any available networks, select your network and enter the password, if required.
- After a short delay, your computer should connect to the Internet.

If your network is not detected, or your computer does not connect to the Internet, please refer to your ISP or router's documentation. After your computer starts and you can use it, open Internet Explorer and follow the instructions.

Alternatively, use a network cable to connect directly to a network port on your router. Please refer to your ISP or router's guide.

REGISTRATION

When using your computer for the first time, it is recommended that you register it. This gives you access to some useful benefits, such as:

- Faster service from our trained representatives.
- Membership in the Packard Bell community: receive promotions and participate in customer surveys.
- The latest news from Packard Bell.

How to register

During the initial startup of your computer, a window will invite you to register. Please fill in the information and click **Next**. The second window you'll see contains optional fields that will help us to provide you with a more personable customer service experience.

Another option

Another way to register your Packard Bell product is to visit our website at **registration.packardbell.com**. Choose your country and follow the simple instructions.

After registering, you will be sent a confirmation email with important information that you should keep in a safe place.

SOFTWARE INSTALLATION

Your computer will automatically install software and prepare your computer for use. This may take some time, please do not turn off your computer; wait until the installation has finished.

RECOVERY

You should create recovery discs as soon as you are able. You will need a pack of writable DVDs. The Packard Bell Recovery Management program allow you to create recovery discs and then to restore or reinstall applications and drivers provided by Packard Bell.

See page 81 for more information about recovery.

HAVING TROUBLE?

Packard Bell provides several options to support your purchase.

Packard Bell support

Make sure you write down your computer serial number, date and place of purchase and model name on the area provided in this guide. Also, save your proof of purchase. Before you call us, please write down any error message that accompanies the problem, and have the computer in front of you and switched on if possible. Having these items to hand when contacting us will ensure better and quicker service.

Packard Bell website

Remember to visit www.packardbell.com! Check out the Support section; it contains up-to-date information, help, drivers and downloads.

Warranty and contact information

You can find information about the warranty for your computer and how to contact technical support in your computer's Warranty.

COMPUTER BASICS

SAFETY AND COMFORT

Safety precautions

Please follow the guidelines below to use your computer comfortably and to avoid health problems.

Computer environment

Make sure that the computer:

- Is used on a stable surface, stand or table. A fall can seriously damage the computer.
- Is not used on a surface that vibrates, or used when taking part in sport, exercise or other activities in a dynamic environment. Vibration or movement can loosen fastenings, damage internal components and even cause battery leakage.
- Is away from direct sunlight and sources of heat.
- Is away from magnetic fields or any device generating static electricity.
- Is kept at least 30 centimetres (one foot) away from a mobile phone.
- Is not in a dusty or damp environment.
- Is not used near water. Never spill liquids of any kind on or into your computer.

- Is not placed on a carpet or any other surface that may have an electrical charge.

Cables

Make sure that:

- Cables are not strained and that there is no risk of people walking or tripping over them.
- Other devices do not crush the cables.
- The power cable is connected to the computer before connecting the power cable to the AC power outlet.
- The power cable is unplugged from the power outlet before disconnecting the power cable from the computer.
- Three-pin power cords are connected to a grounded power outlet.
- The power outlet is easily accessible and as close to the computer as possible (do not overload it with too many adapters).

If your computer uses an external AC adapter:

- Do not cover or place objects on the AC adapter. Allow the adapter to cool properly during use by keeping it clear of objects.
- Only use the AC adapter that is supplied with your computer. Although other adapters may look similar, using them can damage your computer. If a replacement is required, use only parts certified for use with your computer.

Cleaning your computer

- Always unplug your computer from the power outlet before cleaning it.
- Do not use liquid or aerosol cleaners, use a damp cloth instead.
- Never spray cleaning product directly on the screen.

 **Note:** *If your computer includes slots for memory cards or expansion devices, plastic 'dummies' may be installed in the card slots. Dummies protect unused slots from dust, metal objects or other particles. Save the dummies for use when no cards are in the slots.*

Servicing your computer

Do not attempt to service your computer yourself, as opening or removing covers may expose you to dangerous voltage or other risks. Refer all servicing to qualified service personnel.

Unplug your computer from the wall outlet and refer servicing to qualified service personnel when:

- the power cord or plug is damaged, cut or frayed,
- liquid was spilled into the product,
- the product was exposed to rain or water,
- the product has been dropped or the case has been damaged
- the product exhibits a distinct change in performance, indicating a need for service

- the product does not operate normally after following the operating instructions



Note: *Adjust only those controls that are covered by the operating instructions, since improper adjustment of other controls may result in damage and will often require extensive work by a qualified technician to restore the product to normal condition.*

Health precautions

- The computer and accessories may contain small parts. Keep them out of the reach of small children.
- If you work or play for hours at a time, then make sure you take regular breaks. Look away from the computer's screen once in a while. Do not use your computer if you are tired.
- To protect your hearing, when using speakers or headphones, increase volume gradually until you can hear clearly and comfortably; do not increase the volume level after your ears have adjusted. Do not listen to high volumes for extended periods. Do not increase the volume to block out noisy surroundings; decrease the volume if you cannot hear people speaking near you.
- Ensure that the computer's ventilation slots and openings are never obstructed or covered. Do not place the computer on a soft surface (such as a carpet, chair or bed) that may block ventilation slots.
- Do not push objects of any kind into ventilation or case slots as they may touch dangerous voltage points or short-out parts that may result in a fire or electric shock.

- Some disorders of the hands, wrists, arms, neck, shoulders, legs and back may be associated with, or aggravated by certain repetitive actions. To reduce your risk of developing these disorders, type with your wrists straight and your hands and wrists floating above the keyboard. If you experience periods of pain, tingling, numbness or other discomfort, please contact your doctor.
- We advise that parents monitor the use of games by their children. If you or your child experience any of the following symptoms: dizziness, blurred vision, eye or muscle twitches, loss of consciousness, disorientation, any involuntary movement or convulsion, IMMEDIATELY discontinue use and consult your doctor. This may happen even if the person has no medical history of epilepsy.

GETTING TO KNOW YOUR COMPUTER

After setting up your computer, as illustrated in the setup instructions, let us show you around your new Packard Bell computer.





TOP VIEW - DISPLAY





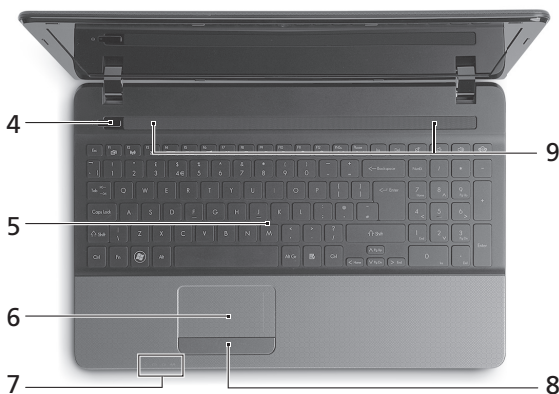

| # | Icon | Item | Description |
|---|------|----------------|---|
| 1 | | Webcam | Web camera for video communication. |
| 2 | | Microphone | Internal microphone for sound recording. |
| 3 | | Display screen | Also called Liquid-Crystal Display (LCD), displays computer output. |

TOP VIEW - KEYBOARD











| # | Icon | Item | Description |
|---|---|--------------------------|--|
| 4 |  | Power button / indicator | Turns the computer on and off. Indicates the computer's power status. |
| 5 | | Keyboard | For entering data into your computer. – <i>Special keys are described on page 17.</i> |
| 6 | | Touchpad | Touch-sensitive pointing device which functions like a computer mouse. |









| # | Icon | Item | Description |
|---|---|--------------------------------|---|
| |  | Power indicator | Indicates the computer's power status. |
| 7 |  | Battery indicator | <p>Indicates the computer's battery status.</p> <ul style="list-style-type: none"> – <i>Charging: The light shows amber when the battery is charging.</i> – <i>Fully charged: The light shows blue when in AC mode.</i> |
| |  | HDD indicator | Indicates when the hard disk drive is active. |
| |  | Communication indicator | Indicates the computer's wireless connectivity device status. |
| 8 | | Click buttons (left and right) | The left and right side of the button function as left and right selection buttons. |
| 9 | | Speakers | Deliver stereo audio output. |

– **Note:** *The front panel indicators are visible even when the computer cover is closed.*

Special keys

Your computer's keyboard includes keys that activate special functions. The function of each key is clearly marked with an icon.

| Icon | Function | Description |
|--|----------------------------|---|
|  | Hotkey for second function | Activates a second function on certain keys. <i>E.g. press the Fn key to activate the F1 to F12 keys.</i> |
|  | Help | Opens the User's Guide for your computer. |
|  | Packard Bell MyBackup | Allows you to create backup copies of your computer; either the entire system or only selected files and folders. Create a regular schedule or make copies whenever you want. |
|  | Communication | Enables/disables the computer's communication devices. |
|  | Display toggle | Switches display output between the display screen, external monitor (if connected) and both. |
|  | Screen blank | Turns the display screen backlight off to save power. Press any key to return. |
|  | Touchpad toggle | Turns the internal touchpad on and off. |
|  | Play/Pause | Play or pause a selected media file. |
|  | Stop | Stop playing the selected media file. |

| Icon | Function | Description |
|--|-------------------|---|
|  | Previous | Return to the previous media file. |
|  | Next | Jump to the next media file. |
|  | Brightness down | Decreases the screen brightness. |
|  | Brightness up | Increases the screen brightness. |
|  | Social Networking | Opens the Social Networks application. – <i>If this application is not installed, the key will start your instant messaging application.</i> |
|  | Volume up | Increases the sound volume. |
|  | Volume down | Decreases the sound volume. |
|  | Speaker toggle | Turns the speakers on and off. |

Hotkeys

The computer uses hotkeys (key combinations) to access function keys and navigation commands.

To activate hotkeys, press and hold the **Fn** key (bottom left) before pressing the other key in the hotkey combination.

| <i>Hotkey</i> | <i>Function</i> | <i>Description</i> |
|---|-----------------|---|
| Fn + Special keys <i>(see page 17)</i> | Function keys | Activates the F1 to F12 keys. |
| Fn + < | Home | Scrolls to the beginning of a document. |
| Fn + > | End | Scrolls to the end of a document. |
| Fn + ^ | Page up | Scrolls up a page in a document. |
| Fn + v | Page Down | Scrolls down a page in a document. |

– *Note: It is not necessary to press the Fn key to use the F1 to F12 function keys when starting your computer or when using the BIOS.*

*To swap the hotkey and special function of the F1 to F12 keys, change the function key setting in the BIOS (to open the BIOS press **F2** when starting your computer, then select the **Main** menu and change **Function key behavior to Function keys**).*

FRONT VIEW



| # | Icon | Item | Description |
|---|---|------------------------|--|
| 1 |  | Multi-in-1 card reader | Accepts Secure Digital (SD), MultiMediaCard (MMC), Memory Stick PRO (MS PRO), xD-Picture Card (xD). – Push to remove/install the card. Only one card can operate at any given time. |



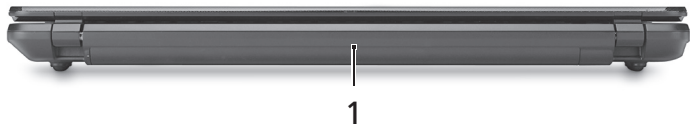

REAR VIEW



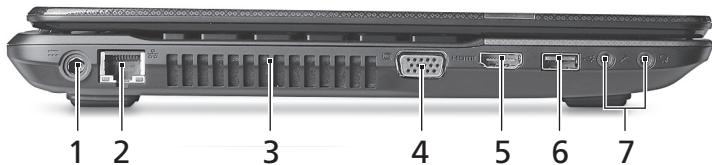

| # | Icon | Item | Description |
|---|------|-------------|-------------------------------------|
| 1 | | Battery bay | Houses the computer's battery pack. |

LEFT VIEW





| # | Icon | Item | Description |
|---|---|-----------------------------|--|
| 1 |  | DC-in jack | Connects to your computer's AC adapter. |
| 2 |  | Ethernet (RJ-45) port | Connects to an Ethernet 10/100/1000-based network. |
| 3 | | Ventilation and cooling fan | Allows the computer to stay cool. – <i>Do not cover or obstruct the openings.</i> |
| 4 |  | External display (VGA) port | Connects to a display device (e.g., external monitor, LCD projector). |
| 5 |  | HDMI port | Supports high-definition digital video connections. |
| 6 |  | USB port | Connect to USB devices (e.g., USB mouse, USB camera). |

| # | Icon | Item | Description |
|---|---|---------------------------|--|
| |  | Microphone jack | Accepts inputs from external microphones. |
| 7 |  | Headphones / speaker jack | <p>Connects to audio line-out devices (e.g., speakers, headphones).</p> <p>– Supports compatible 3.5 mm headsets with built-in microphone (e.g. Acer smart handheld headsets).</p> |

RIGHT VIEW





| # | Icon | Item | Description |
|---|---|---------------|---|
| 1 |  | USB port | <p>Connect to USB devices (e.g., USB mouse, USB camera).</p> <p>– If a port is black, it is USB 2.0 compatible, if a port is blue (optional) it is also USB 3.0 compatible.</p> |
| 2 | | Optical drive | Internal optical drive; accepts CDs or DVDs. |

| # | Icon | Item | Description |
|---|---|-------------------------------|--|
| 3 | | Optical disk access indicator | Lights up when the optical drive is active. |
| 4 | | Optical drive eject button | Ejects the optical disk from the drive. |
| 5 | | Emergency eject hole | Ejects the optical drive tray when the computer is turned off. <i>- Carefully insert a straightened paper clip to eject the optical drive tray.</i> |
| 6 |  | Kensington lock slot | Connects to a Kensington-compatible computer security lock. <i>- Wrap the computer security lock cable around an immovable object such as a table or handle of a locked drawer. Insert the lock into the notch and turn the key to secure the lock. Some keyless models are also available.</i> |

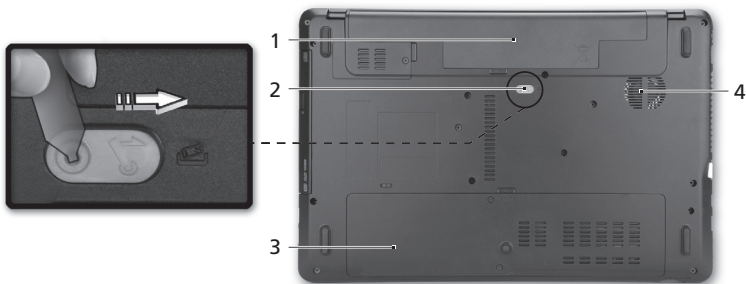
BASE VIEW



| # | Icon | Item | Description |
|---|---|-----------------------------|--|
| 1 | | Battery bay | Houses the computer's battery pack. |
| 2 |  | Battery release latch | Releases the battery for removal. Insert a suitable tool and slide to release. |
| 3 |  | Memory compartment | Houses the computer's main memory. |
| |  | Hard disk bay | Houses the computer's hard disk (secured with screws). |
| 4 | | Ventilation and cooling fan | Allows the computer to stay cool. – Do not cover or obstruct the openings. |

UPGRADING YOUR COMPUTER

EXPANDING THROUGH OPTIONS

Your computer offers you a complete mobile computing experience.

Connectivity options

Ports allow you to connect peripheral devices to your computer. For instructions on how to connect different external devices to the computer, read the following section.

Memory card reader

Memory cards are used in a wide selection of digital cameras, PDAs, MP3 players and mobile phones.

Inserting a memory card

1. Align the card so that the connector points towards the port, with the connectors facing down.
2. Carefully slide the card into the port. If you find you need to use any force to insert the card, try reorientating the card slightly.
3. Push the card until it clicks into place. A few millimetres of the card will extend from beyond the slot.

If the card contains some files, the *Windows Auto Play* window may appear (this depends on the contents of the card) and ask you if you wish to use a program to access the contents of the card. Select an

option here if it is appropriate, otherwise select **Cancel**. If the card contains no files, or unknown files, a window will open showing the contents of the card.

Removing a card from an memory card reader

1. Click on the **Safely Remove Hardware** icon in the *Notification Area* (next to the clock).
2. Click on **Eject SD Card** (or the name of the device).
3. Wait until a *Safe to Remove Hardware* message is displayed.
4. Remove the card.

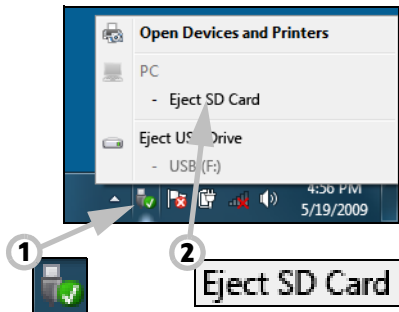

Built-in networking

The built-in networking allows you to connect your computer to an Ethernet-based network.

Connect an Ethernet cable from the Ethernet (RJ-45) port on the chassis of the computer to a network jack or hub on your network.

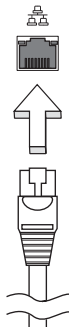

Universal Serial Bus (USB)

The USB port is a high-speed serial bus which allows you to connect USB peripherals without taking up system resources.

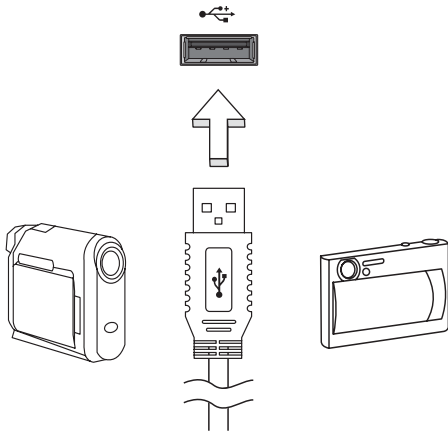

Certain computers may include one or more USB 3.0 ports. These resemble standard USB ports, except they include additional internal connections and are blue. You may use USB 3.0 compatible devices with these ports to benefit from faster transfer speeds.

VGA port

Connect to a monitor with a VGA port. The appropriate cable is usually included with the monitor.

Follow these steps to connect an monitor to your computer:

1. Check that the computer is powered off and the monitor power switch is turned off.
2. Attach the video cable to the monitor port on the computer. Secure the cable connection with the screws provided.
3. Connect the monitor power cable and plug it into a properly grounded wall outlet.
4. Follow any setup instructions in the monitor's user's guide.
5. Turn on power to the monitor, then the computer.
6. Make sure that the current resolution and refresh rate do not exceed the specifications of the monitor. If necessary change the display settings used by the computer.

Note: To access the display controls: Click on **Start, Control Panel, Appearance and Personalization**. Click on the **Display** category, then select **Change Display Settings**.

High-Definition Multimedia Interface (only for certain models)

HDMI (High-Definition Multimedia Interface) is an industry-supported, uncompressed, all-digital audio/video interface. HDMI provides an interface between any compatible digital audio/video source, such as a set-top box, DVD player, and A/V receiver and a compatible digital audio and/or video monitor, such as a digital television (DTV), over a single cable.

Use the HDMI port on your computer to connect with high-end audio and video equipment. Single cable implementation allows tidy setup and fast connection.



Headphones and microphone

These two ports allow you to connect audio devices. Use the headphone port to plug in stereo headphones or powered speakers. Plugging an audio device to the headphone port disables the built-in speakers. Use the microphone port to connect an external microphone for mono recording; plugging in an external microphone disables the built-in microphone.

POWER SUPPLY

AC POWER ADAPTER

Your computer can use the supplied external power adapter (a power 'brick') to run on AC power. A power cable is provided that is appropriate for the country where the computer was purchased.

The power adapter provides adequate power to run your computer and recharge the battery pack at the same time.



Caution: Do not cover or place objects on the AC adapter. Keeping the adapter clear of objects allows the adapter to cool properly during use.

Only use the AC adapter that is supplied with your computer. Although other adapters may look similar, using them can damage your computer.

Warning: The AC adapter and the underside of the computer can become hot after prolonged use. This is normal, but may cause injury with prolonged contact.

BATTERY PACK

The computer uses a battery pack that gives you extended use between charges.

Battery pack characteristics

The battery pack has the following characteristics:

- Employs current battery technology standards.
- Delivers a battery-low warning.

The battery is recharged whenever you connect the computer to the AC adapter. Your computer supports charge-in-use, enabling you to recharge the battery while you continue to operate the computer. However, recharging with the computer turned off results in a significantly faster charge time.

The battery will come in handy when you travel or during a power failure. It is advisable to have an extra fully-charged battery pack available as backup. Contact your dealer for details on ordering a spare battery pack.

Maximizing the battery's life

Like all other batteries, your computer's battery will degrade over time. This means that the battery's performance will diminish with time and use.

To maximize your battery's life, you are advised to adhere to the recommendations set out below.

Conditioning a new battery pack

Before you use a battery pack for the first time, there is a "conditioning" process that you should follow:

1. Insert the new battery without turning the computer on.
2. Connect the AC adapter and fully charge the battery.
3. Disconnect the AC adapter.
4. Turn on the computer and operate using battery power.
5. Fully deplete the battery.
6. Reconnect the AC adapter and fully charge the battery again.

Follow these steps again until the battery has been charged and discharged three times.

Use this conditioning process for all new batteries, or if a battery hasn't been used for a long time. If the computer is to be stored for more than two weeks, you are advised to remove the battery pack from the unit.

Warning: Do not expose battery packs to temperatures below 0 °C (32 °F) or above 45 °C (113 °F). Extreme temperatures may adversely affect the battery pack.

By following the battery conditioning process you condition your battery to accept the maximum possible charge. Failure to follow this procedure will prevent you from obtaining the maximum battery charge, and will also shorten the effective lifespan of the battery.

In addition, the useful lifespan of the battery is adversely affected by the following usage patterns:

- Using the computer on constant AC power with the battery inserted. If you want to use constant AC power, you are advised to remove the battery pack after it is fully charged.
- Not discharging and recharging the battery to its extremes, as described above.
- Frequent use; the more you use the battery, the faster it will reach the end of its effective life. A standard computer battery has a life span of about 300 charges.

Installing or removing the battery pack

Important! Before removing the battery from the unit, connect the AC adapter if you want to continue using your computer. Otherwise, turn off the computer first.

To install a battery pack:

1. Align the battery with the open battery bay; make sure that the end with the contacts will enter first, and that the top surface of the battery is facing up.
2. Slide the battery into the battery bay and gently push until the battery locks in place.

To remove a battery pack:

1. Slide the battery release latch to release the battery.
2. Pull the battery from the battery bay.

Charging the battery

To charge the battery, first make sure that it is correctly installed in the battery bay. Plug the AC adapter into the computer, and connect to a mains power outlet. You can continue to operate your computer on AC power while your battery is charging. However, charging the battery with the computer turned off results in a significantly faster charge time.

Note: *You are advised to charge the battery before retiring for the day. Charging the battery overnight before traveling enables you to start the next day with a fully-charged battery.*

Checking the battery level

The Windows power meter indicates the current battery level. Rest the cursor over the battery/power icon on the taskbar to see the battery's present charge level.

Optimizing battery life

Optimizing battery life helps you get the most out of battery operation, prolonging the charge/recharge cycle and improving recharging efficiency. You are advised to follow the suggestions set out below:

- Purchase an extra battery pack.
- Use AC power whenever possible, reserving battery for on-the-go use.
- Eject a PC Card if it is not being used, as it will continue to draw power (for selected models).
- Store the battery pack in a cool, dry place. The recommended temperature is 10 °C (50 °F) to 30 °C (86 °F). Higher temperatures cause the battery to self-discharge faster.
- Excessive recharging decreases the battery life.
- Look after your AC adapter and battery.

Battery-low warning

When using battery power pay attention to the Windows power meter.

Warning: Connect the AC adapter as soon as possible after the battery-low warning appears. Data will be lost if the battery to become fully depleted and the computer shuts down.

When the battery-low warning appears, the recommended course of action depends on your situation:

| Situation | Recommended Action |
|--|---|
| The AC adapter and a power outlet are available. | <ol style="list-style-type: none"><li data-bbox="337 303 991 370">1. Plug the AC adapter into the computer, and then connect to the mains power supply.<li data-bbox="337 376 991 412">2. Save all necessary files.<li data-bbox="337 417 991 529">3. Resume work. Turn off the computer if you want to recharge the battery rapidly. |
| An extra fully charged battery pack is available. | <ol style="list-style-type: none"><li data-bbox="337 534 991 570">1. Save all necessary files.<li data-bbox="337 576 991 612">2. Close all applications.<li data-bbox="337 617 991 684">3. Shut down the operating system to turn off the computer.<li data-bbox="337 689 991 726">4. Replace the battery pack.<li data-bbox="337 731 991 778">5. Turn on the computer and resume work. |
| The AC adapter or a power outlet is unavailable. You have no spare battery pack. | <ol style="list-style-type: none"><li data-bbox="337 783 991 819">1. Save all necessary files.<li data-bbox="337 824 991 860">2. Close all applications.<li data-bbox="337 866 991 943">3. Shut down the operating system to turn off the computer. |

SOFTWARE

USING WINDOWS AND YOUR SOFTWARE

Packard Bell computers include software to help you use your computer; the programs and categories available on your computer depend on the model purchased. Most of this software is 'pre-installed' and ready to be used; however some software may be provided on a CD or DVD and must first be installed if you wish to use it. To do so, insert the installation CD or DVD. An installation wizard will start automatically and all you have to do is follow the instructions on the screen.

Welcome Center

The first time you turn on your computer, the *Welcome Center* window opens. The *Welcome Center* introduces you to the new features and tools of Windows. You can access the *Welcome Center* later by clicking **Start**  > **Getting Started**.



Internet security offer

It is vital to protect your computer from viruses and attacks over the Internet (see *Security* on page 57). An comprehensive Internet security suite, including a free trial subscription period, is offered when you first start your computer. You should activate this protection before connecting to the Internet. This security suite protects your computer from the most recent online threats and protects your personal data (bank account credentials, credit card numbers, passwords, and more).

Productivity software

Work Great with Microsoft® Office 2010 - Express your ideas, solve problems and simplify everyday projects with Office 2010.

Photo editing - Easily edit and print your photos with Windows Live Photo Gallery. Then share them on Facebook, YouTube™ or Windows Live.

Search & Decide with Bing™ - Find and organize the answers you need using Bing™, so you can make faster, more informed decisions.

Packard Bell Recovery Management

To prepare your computer for system recovery options, you should create a set of recovery discs as soon as possible. See page 81 for more information.

Packard Bell Updater

To ensure that your computer has the latest available updates for drivers and software, please use the *Packard Bell Updater* program as soon as you have configured an Internet connection.

The updater checks for updates every day, but if you want to see if updates are available, you can start the check at any time.

1. Click on **Start**  > **All Programs** > **Packard Bell** > **Packard Bell Updater** or double-click the **Packard Bell Updater** icon on the desktop.
2. *Packard Bell Updater* will search the Packard Bell support website for updates for your computer and display a list of available updates.

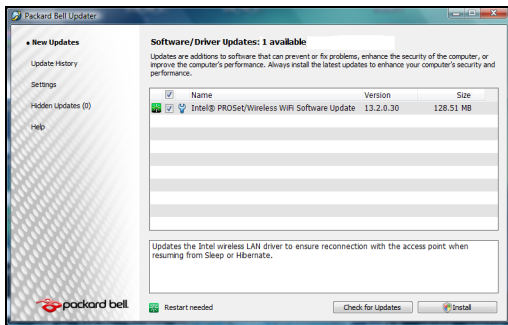

3. Select the updates you wish to install and click on the **Install** button.

Playing multimedia files

You may use the media software on your computer to play music, films or photo slide-shows and watch television (if your computer has a TV tuner). Other options allow you to create CDs or DVDs.

One or more media programs are installed on your computer, *Windows Media Player* and optionally *Windows Media Center* are provided by Microsoft. Other media programs may have been installed by Packard Bell to provide an improved media experience.

Windows Media Player

Windows Media Player may be used to play MP3 or WMA audio files, CDs or most video files.

 **Note:** *It is not recommended that you use Windows Media Player to play DVD movies. Other media players (such as Windows Media Center) provide additional playback options.*

Windows Media Center (optional)

Certain computers include all-in-one media 'centers' such as *Windows Media Center*. These programs can handle a variety of multimedia content, presented with simple menus that may be easily controlled with a remote control. You may watch live or recorded TV

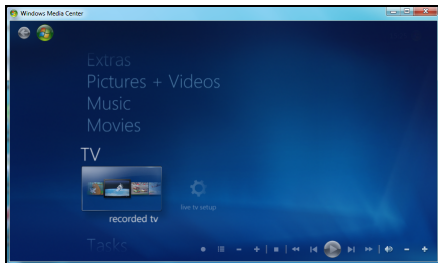

(if your computer has a TV tuner), listen to digital music, view pictures and personal videos, create CDs and DVDs, or access content from online services.

To start the media program installed on your computer, click on **Start > Windows Media Center**.

Setup

 **Caution:** If your computer includes a remote control (page 11) or TV tuner (page 15) they must be connected and active before starting the media program for the first time.

The first time you start the media program, it will start a setup wizard, which will configure some basic settings. If available, select the *Express* setup option, you may then configure additional options as needed.

 **Note:** If you have an Internet connection, the **Guide** (*Electronic Program Guide*) allows you to view a list of current TV shows. This shows channel and network information, as well as the title, description and scheduled broadcast time of shows.

Cyberlink PowerDVD (optional)

If your computer is equipped with a Blu-ray drive, you may watch Blu-ray movies with *PowerDVD*. You may start *PowerDVD* by inserting a Blu-ray disc and waiting for the program to start automatically.

AutoPlay

The *Windows AutoPlay* function allows you to choose the way Windows handles media files on devices with removable storage (digital camera, CD, DVD, etc).

If you have inserted a disk that contains files (such as a DVD, USB key or memory card), Windows will display a dialogue box and ask you to choose how you want to open the files.

For example, if you have inserted an audio CD or a DVD movie, Windows will automatically display a dialogue box and ask you to choose how you want to play it. If Windows asks you to select a DVD player, we recommend that you always choose the DVD player included with your software collection (e.g. *PowerDVD* or *Windows Media Player*).

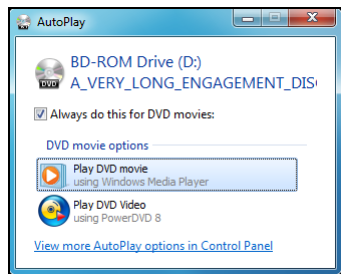

Playing downloaded files

Downloaded files may work with the media programs installed on your computer, or may require specific programs. Files that include DRM functions may only play in specific programs (e.g. iTunes, Windows Media Player) or only on devices certified for use with the each type of file. Other formats may require a specific audio or video *codec* that may not have been installed on your computer.

Codecs

A codec is software that is used to **compress** or **decompress** a digital media file, such as a song or video. Windows Media Player and other programs use codecs to play and create digital media files.

For example, when you rip a song from an audio CD to your computer, the player uses the Windows Media Audio codec to compress the song into a compact WMA file. When you play that WMA file (or any WMA file that might be streamed from a Web site), the media player uses the Windows Media Audio codec to decompress the file so the music can be played through your speakers.

Why do I get a message that says my computer is missing a codec?

If you get a message that says that your computer is missing a codec, it may be because you are using a file that was compressed using a codec that Windows or the media player does not include by default. In many cases, you can download and install the missing codec by clicking on the Web Help button in the error message.

Please also see *Windows Help and Support* for more information.

Playing DVD movies

You can play DVD movies on your computer.

1. Insert the DVD.

Important! *When you launch the DVD player for the first time, the program asks you to enter the region code. DVD content is coded with one of six regions. Please refer to the table below for DVD*

movie region code information.

Once your DVD drive is set to a region code, it will play DVD discs of that region only. You can set the region code a maximum of five times (including the first time), after which the last region code set will remain permanent. Recovering your hard disk does not reset the number of times the region code has been set.

2. The DVD movie will automatically play after a few seconds.

| Region code | Country or region |
|-------------|--|
| 1 | USA, Canada |
| 2 | Europe, Middle East, South Africa, Japan |
| 3 | Southeast Asia, Taiwan, South Korea |
| 4 | Latin America, Australia, New Zealand |
| 5 | Former USSR, parts of Africa, India |
| 6 | People's Republic of China |

Note: *To change the region code, insert a DVD movie of a different region into the DVD drive. Please refer to the online help for more information.*

Social networks (optional)

The *Social Networks* application allows you to quickly view your friends' updates, and make your own updates without leaving the desktop. You can receive notifications and status updates directly to your desktop, using the sidebar to monitor multiple social networks (*Facebook*, *YouTube* and *Flickr*).

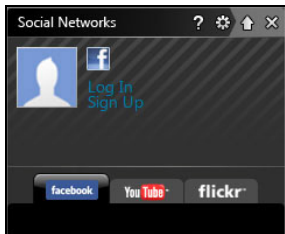

Note: *The Social Networks application is a pre-installed option and may not be installed on all computers.*

Be aware of your friends' messages and posted images as they happen; a visible notification will alert you whenever a friend (or subscription) shows some activity.

If your computer's keyboard features the optional *Social Networks* key (normally the top-right key), press it to display the *Social Networks* application.



Log in... or Sign up

The top of the application shows your profile picture and account information from Facebook. If you have not yet created or accessed your Facebook profile, the top image is the anonymous white-on-blue placeholder, and no information is shown.

When you first start the *Social Networks* application, you will be asked to *Log in* to your social networks. If this does not happen

automatically, click **Log In**, at the top of the *Social Networks* window. If you just want to create a new Facebook profile, click **Sign Up** and follow the instructions.

***Note:** All social activities require Internet access. Make sure you are connected to the Internet before using this application.*

Authorize access

To receive updates, you must authorize access to your social network accounts; each account must be activated separately. Click on the tab for the network you want to activate (Facebook, YouTube or Flickr).

You need your account name and password for each network, or to create a new account if you do not have one.

***Note:** Note down all information you use for new accounts, including the account name, email address and password. Keep this information hidden in a safe place, so you may refer to it when you access your accounts in the future.*

Facebook

If you already have a Facebook account, click the **Log In** button to activate access, or **Sign up to Facebook** to create an account.

If you choose **Sign up to Facebook** please fill in the requested information, with your email and an appropriate password. You will then continue to authorize access for your account.

Please allow access for all steps, this will ensure all *Social Networks* features work normally.

YouTube

If you already have a YouTube account, enter the account information and click the **Log In** button to activate access, otherwise select **Sign up to YouTube** to create an account.

flickr

If you already have a flickr account, click the **Log In** button to activate access, otherwise select **Sign up to flickr** to create an account. Confirm that you authorise full access, this will ensure all *Social Networks* features work normally.

Accessing your social networks



Once you have authorized access, your profile picture and status information will be displayed. You may update this information with a click.

Quick actions

Click on a link to see more in a new window. I.e. click on a Facebook entry to open your Facebook account and view the entire entry; click on a YouTube video title to view the video.

Enter your status in the *What's on your mind?* box and click **Share**. Your friends on Facebook will see your status instantly.

To create a new album of photos in Facebook, select the images you want to add, drag them to your profile picture. You will be prompted for an album name and description. Click on **Upload** to start copying the images to your Facebook account.

Click the arrows in the bottom bar   to see more pages, if there are more entries than can be shown on a page.

Click on the question mark in the top bar  to see the help file for *Social Networks*.

Click on the arrow in the top bar  to hide the full application and display a small alert bar on the top of your screen. Click the alert bar (below) to see the full window with a summary of your friends' activities.



Note: Do not use the *X* icon to exit Social Networks, unless you want to stop sending or receiving updates. Use the arrow in the top bar  to display the alert bar.

Checking your news feeds and information

Select the tab for the network you want to view:



A series of buttons for the network are available for each network. Hover over the button to see a description. Select the button you want to see and scroll through the list of items.

Example of Facebook tabs:



The first button, and the section viewed when a tab is first selected, are the *News Feed* (for Facebook), *Most Viewed* for YouTube and *Contacts* for Flickr. If there are more entries than can be shown on one page, use the arrows in the bottom bar to see more pages.

Changing settings

Click the settings icon  to access settings for the social networks.

Live Update - If the *Live Update* button is active, you may download and install an updated version of the *Social Networks* application.

Click the tab for a network to see specific settings; you may set how often a network is checked (the refresh frequency) and logout from specific networks in this section.

Click the **X** to exit the Settings section.

INTERNET

FIRST STEPS ON THE NET

Protecting your computer

It is vital to protect your computer from viruses and attacks over the Internet (see *Internet security offer* on page 38 and *Security* on page 57). A comprehensive Internet security program is offered when you first start your computer. You should activate this protection as soon as possible, certainly before you connect to the Internet.

Choose an Internet Service Provider



Using the Internet has become a natural part of daily computing. Just a few simple steps can connect you to a vast collection of knowledge and communication tools. To accomplish these steps you should first select an *Internet Service Provider (ISP)*, which supplies the connection between your computer and the Internet. You should research the ISPs available in your region, not forgetting to talk to friends and family about their experiences or to check reviews and consumer reports. The ISP you select will provide instructions on how to connect to the Internet (you may need additional software or a special 'box' that connects to your phone line).

Connection types

Depending on your computer model, your location and your communication needs, you have several ways to connect to the Internet.

Dial-up

Some computers include a telephone dial-up ('modem') connector. This allows you to connect to the Internet using your telephone line. With a dial-up connection, you cannot use the modem and the telephone simultaneously on a single phone line. This type of connection is recommended only if you have limited use of the Internet as the connection speed is low and connection time is typically charged per hour.

DSL (e.g. ADSL)

DSL (Digital Subscriber Line) is an 'always-on' connection that runs over the phone line. As DSL and phone do not use the same frequencies, you can use your telephone at the same time you are connected to the Internet (this requires a 'micro-filter' on each telephone socket to avoid interference). To be eligible for DSL, you must be located near an DSL-equipped phone exchange (service is sometimes unavailable in rural areas). Connection speeds vary depending on your location, but DSL generally provides very fast and reliable Internet connection. As the connection is always-on, it is generally charged at fixed monthly rates.



Note: A DSL connection requires an appropriate modem. A modem is usually provided by the ISP when you register. Many of

these modems include an 'router' that provides network and wi-fi access.

Cable

A cable connection provides fast and 'always-on' Internet service via a cable television line. This service is generally available in large cities. You can use your telephone and watch cable TV at the same time you are connected to the Internet.

Network connections

A LAN (Local Area Network) is a group of computers (for example, within an office building or home) that share a common communications line and resources. When you set up a network, you can share files, peripheral devices (such as a printer) and an Internet connection. You can set up a LAN using wired technologies (such as Ethernet) or wireless technologies (such as WiFi or Bluetooth).

Wireless networks

A wireless LAN or WLAN is a wireless local area network, which may link two or more computers without using wires. Setting up a wireless network is easy and allows you to share files, peripheral devices and an Internet connection.

What are benefits of a wireless network?

Mobility

Wireless LAN systems allow you and other users of your home network to share access to files and devices connected to the network, for example a printer or scanner.

Also you can share an internet connection with other computers in your home.

Installation speed and simplicity

Installing a wireless LAN system can be fast and easy and eliminates the need to pull cables through walls and ceilings.

Components of a wireless LAN

To set up your Wireless network at home you need to have the following:

Access point (router)

Access points (routers) are two-way transceivers that broadcast data into the surrounding environment. Access points act as a mediator between wired and wireless network. Most routers have a built-in DSL modem that will allow you access to a high speed DSL internet connection. The ISP (Internet Service Provider) you have chosen normally supplies a modem/router with the subscription to their services. Read carefully the documentation supplied with your Access point/router for detailed setup instructions.

Network cable (RJ45)

A network cable (also called RJ45 cable) is used to connect the host computer to the access point (see illustration below); this type of cable may also be used to connect peripheral devices to the access point.

Wireless adapter

Diagram of a working network

1. Access point/router
2. Desktop computer
3. Modem
4. Printer
5. Portable computer
6. PDA/Smartphone
7. Network cables (RJ45)

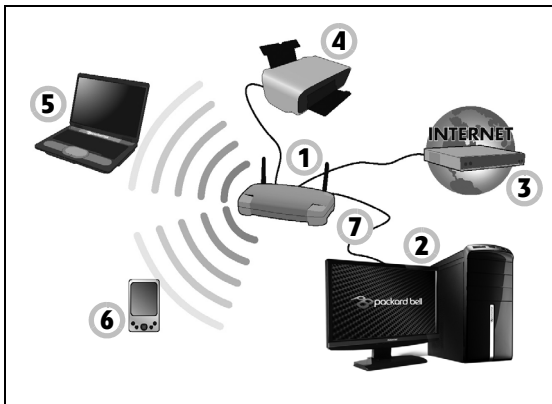

Turning on/off a wireless network connection

If your computer has wireless access, but does not feature a *Communication* button, you may turn your wireless network on or off, or control what is shared over the network with the network management options. Click on **Start**  > **Control Panel** > **Network and Internet** > **Network and Sharing Center**.

Surf the Net!

To surf the Internet, you need a program called an Internet browser. *Internet Explorer* provides an easy and secure web browsing experience. As soon as you have your Internet access installed and you are connected, click on the Internet Explorer shortcut located on the Windows desktop and take your Internet experience to a new level!



Internet Explorer features

The image below shows the Internet Explorer browser's start page. A brief description of some key aspects of the browser are listed below.

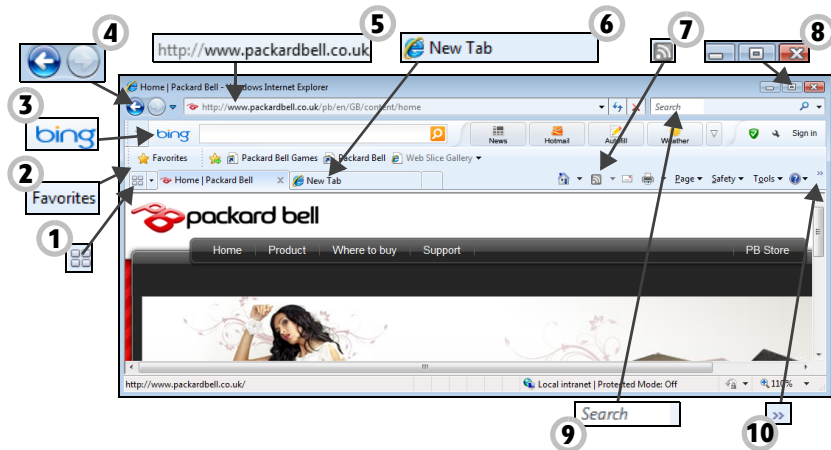

1. Quick tabs: Select and navigate through open tabs by displaying thumbnails of them all in a single window.
2. Favourites Center: Manage your favourite websites, your browsing history and your RSS Feed subscriptions in just a few clicks.
3. Bing Bar: Search the web and use Bing tools to alert you of news, fill forms automatically, stay safe online and more.
4. Back and Forward buttons: Navigate through pages you have already visited.
5. Address bar: Type in an Internet address (e.g. www.packardbell.com) and press the Enter key on your keyboard, this will take you directly to the address you typed.
6. Tabs: View multiple sites in a single browser window by switching from one site to another through tabs at the top of the browser frame.
7. RSS feeds: Allow you to keep up with your favourite websites in an automated manner. An icon on the toolbar indicates that the site offers a subscription feed that will notify you when content is updated. Your browser delivers the information to your Favourites Center. Now you can read news headlines, sports scores, etc. as soon as they arrive.
8. Reduce, maximize or close the window.
9. Instant Search Box: Search the web without having to open a search provider page. You can customize your search by setting your favorite search provider as the default. Use the dropdown list to choose a provider.

10. Link to the Help menu: click to access the Internet Explorer Help section. There you can find information about Internet Explorer and take the Internet Explorer Tour. You may also press **F1** on your keyboard.

Caution: Internet Explorer includes a *Phishing Filter* that warns you about and helps to protect you from potential or known fraudulent websites (sites that look legitimate but actually are designed to capture your personal information). The address bar will turn yellow and a warning message will be displayed if you visit a suspected phishing site.

Packard Bell website

To get you started why not visit our website, www.packardbell.com.

Packard Bell is dedicated to provide you with on-going personalised support. Check out our *Support* section to get help tailored to your needs.

www.packardbell.com is your gateway to a world of online activities and services: visit us regularly for the latest information and downloads!

Security

You are probably eager to explore everything the Internet has to offer. In order for you to be safe online, Packard Bell has pre-installed Symantec's award-winning Norton Internet Security™ on your computer.

Norton Internet Security runs quietly in the background to block today's complex threats and protect your identity when you shop, bank, or browse online.

Norton Internet Security blocks online identity theft, detects and eliminates spyware, removes viruses and Internet worms, protects against hackers.

Definitions

What is a virus?

Malicious software, typically called 'viruses', are programs designed to infect and damage computers. Most viruses are transmitted over the Internet, emails or malicious Web sites. A typical virus will replicate and pass itself undetected to multiple computers. Other forms of nuisance, such as Trojan horses, worms or spam can infect your computer in various ways, using up resources or clogging up a network.

 **Note:** *Packard Bell guarantees that your computer was 100% virus free at the time of purchase and does not cover damages due to viruses.*

What is spyware?

Spyware refers to generally unwanted programs that are downloaded onto your computer while connected to the Internet, often without you knowing it. Once it has infected your computer, it can snoop on your browsing activity, collect personal information, cause pop-up ads to appear, or even change the configuration of your computer.

Spyware consumes resources on your computer; it can slow down your Internet connection or entire computer system, and even cause crashes.

Spyware is sometimes used by unscrupulous companies to monitor and track the sites you visit on the Internet so as to determine your web-surfing habits and display targeted pop-up ads on your screen. However, some kinds of spyware go beyond simple tracking and actually monitor keystrokes and capture passwords, posing a serious security risk.

What is malware?

Malicious software, also known as *malware*, is software designed to deliberately harm your computer. For example, viruses, worms, and Trojan horses are malicious software. To help protect your computer against malware, make sure it is using up-to-date antivirus and anti-malware software.

What is a personal firewall?

A personal firewall is a software program designed to prevent unauthorized access to or from a private network. It acts as a shield to protect your Internet connection from unwanted connections, some of which may attempt to take control of your computer to install or re-distribute viruses or malicious programs. Each connection to your computer is monitored - programs that attempt to receive information without your permission are detected and the firewall will display an alert. You can then decide if you will allow the connection, if the connection is to a program you are currently using

then normally you would allow it (i.e. a game connecting to a multi-player server or an encyclopaedia making a content update).

How to protect your computer

Cybercrime prevention can be straight-forward - when armed with a little technical advice and common sense, many attacks can be avoided. In general, online criminals are trying to make their money as quickly and easily as possible. The more difficult you make their job, the more likely they are to leave you alone and move on to an easier target. The tips below provide basic information on how you can prevent online fraud.

Keep your computer current with the latest patches and updates

One of the best ways to keep attackers away from your computer is to apply patches and other software fixes when they become available. By regularly updating your computer, you block attackers from being able to take advantage of software flaws (vulnerabilities) that they could otherwise use to break into your system.

While keeping your computer up-to-date will not protect you from all attacks, it makes it much more difficult for hackers to gain access to your system, blocks many basic and automated attacks completely, and might be enough to discourage less-determined attackers, so they will give up and look for a more vulnerable computer elsewhere.

More recent versions of Microsoft Windows and other popular software can be configured to download and apply updates automatically so that you do not have to remember to check for the

latest software. Taking advantage of auto-update features in your software is a great start toward keeping yourself safe online.

Protect your computer with security software

Several types of security software are necessary for basic online security. Security software essentials include firewall and antivirus programs. A firewall is usually your computer's first line of defense-it controls who and what can communicate with your computer online. You could think of a firewall as a sort of "policeman" that watches all the data attempting to flow in and out of your computer on the Internet, allowing communications that it knows are safe and blocking "bad" traffic such as attacks from ever reaching your computer.

The next line of defense many times is your antivirus software, which monitors all online activities such as email messages and Web browsing and protects an individual from viruses, worms, Trojan horse and other types of malicious programs. Your antivirus and antispyware software should be configured to update itself, and it should do so every time you connect to the Internet.

Integrated security suites such as Norton Internet Security, which combine firewall, antivirus, antispyware with other features such as antispam and parental controls, have become popular as they offer all the security software needed for online protection in a single package. Many people find using a comprehensive security suite an attractive alternative to installing, configuring and updating several different types of security software.

A complete version of Norton Internet Security™ is pre-installed on your Packard Bell system. It includes a free trial subscription to protection updates. Make sure you Activate it!

Choose strong passwords and keep them safe

Passwords are a fact of life on the Internet today; we use them for everything from ordering flowers and online banking to logging into our favorite airline Web site to see how many miles we have accumulated. The following tips can help make your online experiences secure:

- Selecting a password that cannot be easily guessed is the first step toward keeping passwords secure and out of the wrong hands. Strong passwords have eight characters or more and use a combination of letters, numbers and symbols (e.g., # \$ % ! ?). Avoid using any of the following as your password: your login name, anything based on your personal information such as your last name, and words that can be found in the dictionary, especially "password". Try to select especially strong, unique passwords for protecting activities like online banking.
- Keep your passwords in a safe place and try not to use the same password for every service you use online.
- Change passwords on a regular basis, at least every 90 days. This can limit the damage caused by someone who has already gained access to your account. If you notice something suspicious with one of your online accounts, one of the first steps you can take is to change your password.

Protect your personal information

Exercise caution when sharing personal information such as your name, home address, phone number, and email address online. To take advantage of many online services, you will inevitably have to provide personal information in order to handle billing and shipping of purchased goods. Since not divulging any personal information is rarely possible, the following list contains some advice for how to share personal information safely online:

- **Keep an eye out for phony email messages.** Things that indicate a message may be fraudulent are misspellings, poor grammar, odd phrasings, Web site addresses with strange extensions, Web site addresses that are entirely numbers where there are normally words, and anything else out of the ordinary. Additionally, phishing messages will often tell you that you have to act quickly to keep your account open, update your security, or urge you to provide information immediately or else something bad will happen. Don't take the bait.
- **Don't respond to email messages that ask for personal information.** Legitimate companies will not use email messages to ask for your personal information. When in doubt, contact the company by phone or by typing in the company Web address into your Web browser. Don't click on the links in these messages as they make take you to fraudulent, malicious Web sites.
- **Steer clear of fraudulent Web sites used to steal personal information.** When visiting a Web site, type the address (URL) directly into the Web browser rather than following a link within an

email or instant message. Fraudsters often forge these links to make them look convincing.

A shopping, banking or any other Web site where sensitive information should have an "S" after the letters "http" (i.e. *https://www.yourbank.com* not *http://www.yourbank.com*). The "s" stands for secure and should appear when you are in an area requesting you to login or provide other sensitive data. Another sign that you have a secure connection is the small lock icon in the bottom of your web browser (usually the right-hand corner).

- **Pay attention to privacy policies on Web sites and in software.** It is important to understand how an organization might collect and use your personal information before you share it with them.
- **Guard your email address.** Spammers and "phishers" sometimes send millions of messages to email addresses that may or may not exist in hopes of finding a potential victim. Responding to these messages or even downloading images ensures you will be added to their lists for more of the same messages in the future. Also be careful when posting your email address online in newsgroups, blogs or online communities.

Online offers that look too good to be true usually are

The old saying "there's no such thing as a free lunch" still rings true today. Supposedly "free" software such as screen savers or smileys, secret investment tricks sure to make you untold fortunes, and contests that you've surprisingly won without entering are the enticing hooks used by companies to grab your attention.

While you may not directly pay for the software or service with money, the free software or service you asked for may have been bundled with advertising software ("adware") that tracks your behavior and displays unwanted advertisements. You may have to divulge personal information or purchase something else in order to claim your supposed content winnings. If an offer looks so good it's hard to believe, ask for someone else's opinion, read the fine print, or even better, simply ignore it.

Review bank and credit card statements regularly

The impact of identity theft and online crimes can be greatly reduced if you can catch it shortly after your data is stolen or when the first use of your information is attempted. One of the easiest ways to get the tip-off that something has gone wrong is by reviewing the monthly statements provided by your bank and credit card companies for anything out of the ordinary.

Additionally, many banks and services use fraud prevention systems that call out unusual purchasing behavior (i.e. if you live in Texas and all of the sudden start buying refrigerators in Budapest). In order to confirm these out of the ordinary purchases, they might call you and ask you to confirm them. Don't take these calls lightly; this is your hint that something bad may have happened and you should take necessary action.

Protect your computer with Windows security tools

Windows provides a variety of protection applications.

Windows Action Center

Windows provides a central area from where you can control the security settings of your computer, helping you to protect it from Internet attacks and ensuring that the latest security updates have been downloaded and installed on your computer.

To open the *Action Center*, click on **Start**  > **Control Panel** > **System and Security** > **Action Center**.

Alternatively, if a security alert has been reported (in the Notification Area, next to the clock) then you can click on the notification balloon or double-click on the small Security Alert icon.

The *Action Center* indicates the status and settings used for important applications that protect your computer. In addition *Windows Firewall*, *Windows Defender* and *Windows Automatic Updates* are provided by Microsoft as part of a comprehensive system to defend your computer. The antivirus application varies according to the program installed on your computer.

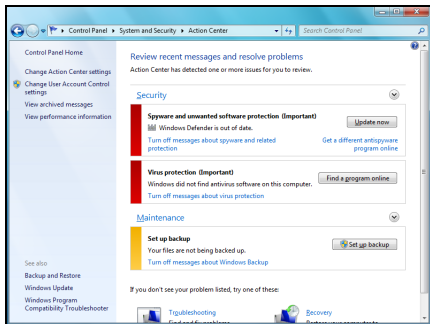

Windows Firewall

Windows has a firewall that protects your computer when connected to the Internet. It stops programs from accessing the Internet without your permission.

Certain programs need access to the Internet to function properly, or even to function at all. If this is the case, you will usually be asked to allow access when you install a program, or the first time you use it. To check firewall settings, click on **Start** > **Control Panel** > **System and Security** > **Windows Firewall**.

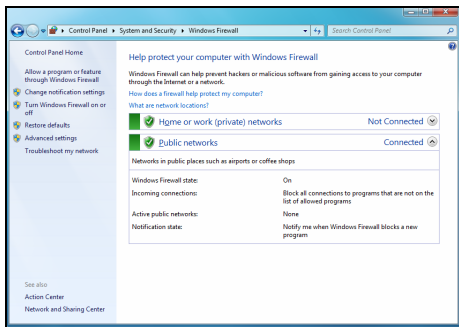

 **Note:** When you first start to use a Firewall it is in a 'Learning mode', you may see pop-up windows alerting you that certain programs you know and trust wish to access the internet. After a period of time the Firewall will know your list of trusted programs and won't ask for permission the next time the program tries to connect to the internet. The Firewall also protects your computer from programs from the internet trying to access your computer; this sometimes is necessary to allow access for program updates, downloads, etc.

Caution: Please note that most security software suites provide similar functionality and will disable Windows Firewall in order to improve system performance.

Windows Updates

If you have an active Internet connection, Windows can check for important updates for your computer and install them automatically. These updates include security patches and program updates that can improve your computing experience and help protect your computer against new viruses and attacks.

Windows Defender

Windows Defender helps protect your computer against malicious and unwanted software, such as spyware and adware. *Windows Defender* is installed and turned on by default.

To help protect your privacy and your computer, Windows Defender includes *real-time protection* options. Real-time protection alerts you when spyware and other potentially unwanted software attempt to install themselves or run on your computer. You are also alerted if programs attempt to change important Windows settings.

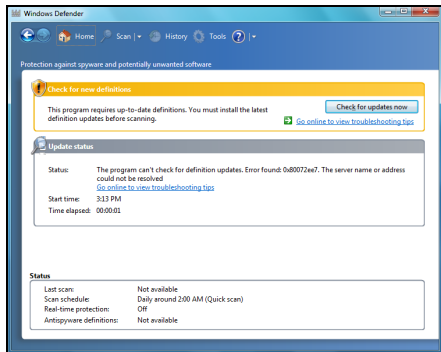

 **Note:** Windows Defender works with your Windows Update settings to automatically install the latest definitions.

Caution: Please note that most security software suites provide similar functionality and will disable Windows Defender in order to improve system performance.

User Account Control

The *User Accounts* control panel can help prevent unauthorized changes to your computer. User Accounts will ask you for permission or an administrator password before performing actions that could potentially affect your computer's operation or that change settings that affect other users. When you see a User Account

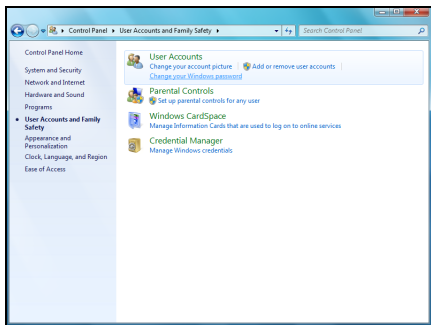

message, read it carefully, and then make sure the name of the action or program that's about to start is one that you intended to start.

By verifying these actions before they start, User Account settings can help prevent malicious software (malware) and spyware from installing or making changes to your computer without permission.

To access *User Account* settings, click on **Start**  > **Control Panel** > **User Accounts and Family Safety** > **User Accounts**.



Note: You may turn off the User Account Control Messages (not recommended) in the User Account Control settings window.

Internet Explorer security settings

Internet sites use small files called cookies to keep track of user preferences and information. You can adjust your Internet browser's security settings to determine how much -or how little- information you are willing to accept from a Web site.

To access Internet Explorer security settings:

1. In Internet Explorer, click on **Tools > Internet Options**.
2. In the **Privacy** tab, move the slider up or down to select a setting.

How do I know when my computer is at risk?

If the *Action Center* reports an alert, or if your computer behaves erratically, crashes unexpectedly or if some of your programs do not work correctly, your computer may be infected by malicious software. However, do not blame every computer problem on a virus! If you suspect your computer is infected, the first thing to do is update, if you have not already done so, and run your antivirus and anti-spyware software.

HELPDESK

SAFE COMPUTING

To make the most of your new computer and ensure it runs smoothly for a long time, you should use the programs below and regularly perform the actions described in this guide.

Maintenance

Recommended maintenance tasks

There are several tasks you should perform periodically (about once per month) to ensure your computer stays in good health:

Error checking

Using the *Check Disk* tool regularly prevents your system from getting unreliable and information getting lost. It checks and repairs two types of errors:

- file system errors, such as fragmented files that were not deleted and files with invalid sizes or dates;
 - physical errors, which may occur on your hard disk as it wears out over time.
1. Click on **Start**  > **Computer**. Right-click on the **Packard Bell (C:)** icon and select **Properties**.
 2. Click on **Tools** and **Check Now** in the *Error-checking* section.

3. Tick **Automatically fix file system errors** in the options area. If you tick **Scan for and attempt recovery of bad sectors**, your computer will carry out the physical error checking when you next restart your computer. Click on **Start** to proceed.

Disk Cleanup

The *Disk Cleanup* Wizard helps free up space on your disk drive. It searches your drive and displays unused files, such as temporary Internet files, files in the Recycle Bin and other temporary files that you may safely delete.

1. Click on **Start**  > **Computer**. Right-click on the **Packard Bell** icon and select **Properties**.
2. Select the **General** tab and click on the **Disk Cleanup** button (next to the diagram of the disk drive).
3. Tick each category in the *Files to delete* area you wish to delete and click on **OK**.

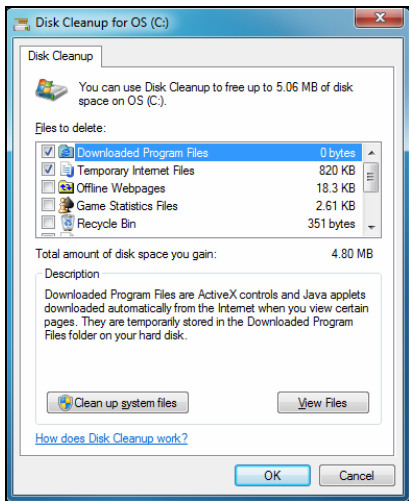

Disk Defragmenter

With the creation and deletion of files over time, scattering occurs all over the hard disk area and affects performance. The *Disk Defragmenter* helps you rearrange the items stored on your hard drive to make your computer run faster and more efficiently.

Running the *Disk Defragmenter* once a month (depending on computer usage) will decrease wear and tear on your hard drive and thus decrease the chance of a fault developing at a later date.

1. Perform a *Disk Cleanup* and close all open programs.
2. Click on **Start**  > **Computer**. Right-click on the **Packard Bell** icon and select **Properties**.
3. Click on **Tools** and **Defragment now....**
4. Click on the volume you want to defragment and click on **Defragment** to start. The whole process may take

several hours to complete. It is best not to use your computer while running the *Disk Defragmenter* as any changes on your system may cause the process to restart. If your hard disk is divided into several partitions you should perform the same action for each partition.

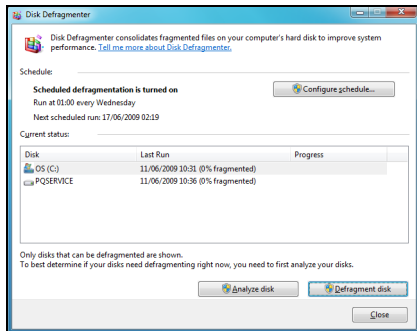

Manage your hard disk drive (HDD)

Check the remaining free space on your hard disk drive

1. Click on **Start**  > **Computer**.
2. Right-click on the **Packard Bell** icon and select **Properties**.
3. The *Hard Disk Properties* window displays the amount of used space and free space on your hard disk. If your hard disk is almost full (less than 200 MB remaining), you should consider freeing some space.

To see easily how much space is used and how much is left, simply place your pointer over the hard disk drive icon. The information will automatically appear.

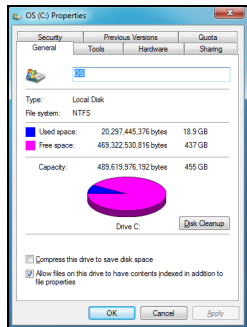

Free some Space on your hard disk drive

1. Empty the Recycle Bin: When you delete a file from your computer, Windows places it in the Recycle Bin. All the deleted files remain there until you decide to permanently delete them from your computer or to restore them to their original location. Double-click on the **Recycle Bin** on the Windows desktop and click on **Empty Recycle Bin** or select only the items you want to delete. Items deleted from external devices, such as memory cards, do not go to the Recycle Bin, they are permanently deleted.



2. Uninstall the programs you no longer use:

Click on **Start**  > **Control Panel** > **Programs** > **Programs and Features**.

3. Archive files on an external hard disk drive, recordable CDs or DVDs (if your computer is equipped with a CD or DVD writer) and delete them from the hard disk.

Run Windows System Tools

Windows includes some convenient tools to keep your computer in good shape. Use these tools on a regular basis to maintain a reliable and speedy system! To make it easier, *System Tools* includes a *Scheduled Tasks* utility, which you can customise to run specific tasks regularly.

To access the list of *System Tools*, click **Start**  > **All Programs**, then the **Accessories** folder in the list of programs and finally select **System Tools**.

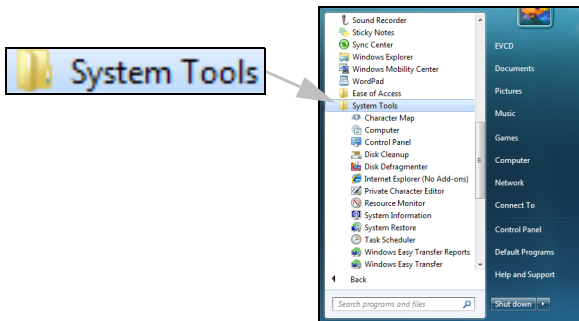

Windows System Restore.

System Restore monitors changes to your computer and automatically creates restore points that store your computer's configuration each time a major change occurs (such as installing programs). It can undo harmful changes to your computer and restore settings and performance without removing your personal data files (such as documents, browsing history, photos, favourites, or emails).

 **Note:** *If you only need to uninstall a program, do not use System Restore. To uninstall a program use **Programs and Features** in the Control Panel.*

To start System Restore from the Windows desktop:

Click **Start**  > **All Programs** > **Accessories** > **System Tools** > **System Restore**.

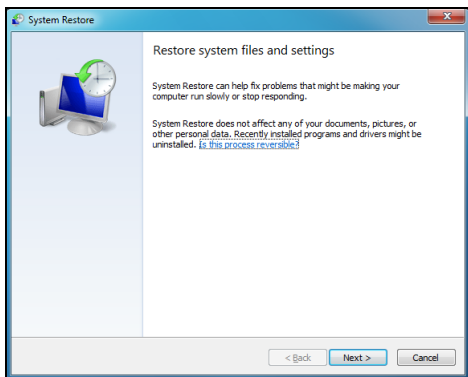

If you cannot access the Windows desktop:

1. Press the **Alt+F10** key upon start-up when the Packard Bell logo appears. This will open the *Recovery Program*.
2. Select **Windows System Restore** and click **Next**. Your computer will automatically restart and open *System Restore*.

System Restore options

Restore your computer to an earlier time

This option will return to your computer to how it was on an earlier date, without affecting your personal documents or emails (it will not restore lost documents either). By default Windows saves snapshots of itself when major changes are made to the Operating System (e.g. driver installations or specific software). This is useful when a driver installation failed, or when you changed a system setting, and it did not work.

1. Click **Next**.
2. Select from the list the date when the restore point was created and click **Next**.
3. In the confirmation screen, click on **Finish** to restore the computer to the selected date and time.

Create a Restore Point

Windows creates restore points automatically at regularly scheduled times or before certain programs or drivers are installed. This option allows you to create your own restore points when you need to.

1. Click **Start**  > **Control Panel** > **System and Security** > **System**. Click on **System protection** in the sidebar and then click the **Create...** button.
2. Enter a description to identify this restore point. *System Restore* automatically adds the date and time to this name.
3. To finish, click on **Create**.

Undo the last restoration

If the system fails after restoring the computer to a certain date, you can use this option to undo the restoration.

Alternately, you can use *Last Known Good Configuration* to restore the system to your most recent settings that worked.

1. Restart the computer, press **F8** to access advanced startup options.
2. Use the arrow keys to highlight **Last Known Good Configuration** and press **Enter**.

Updates

As new viruses, worms, and other threats are discovered every day, keeping your security applications and operating system up-to-date is crucial.

To keep your computer safe and reliable:

- Perform updates when prompted by *Windows Action Center*.
- Use Microsoft *Windows Automatic Updates*.
- Run *Windows Update*.

Internet security

Norton Internet Security, combined with other security applications can protect your computer from Internet attacks and ensure that the latest security updates have been downloaded and installed on your computer. *Norton Internet Security* performs automatic updates through *Live Update*. You can also start a manual update from the main interface of *Norton Internet Security* and the *Live Update* link.

Operating system, software and drivers

Windows Update can help you keep your computer up-to-date. It allows you to choose and download updates for your computer's operating system, software, and hardware.

New content is added to *Windows Update* regularly, so you can always get the most recent updates and solutions to protect your computer and keep it running smoothly.

- Start  > Control Panel > System and Security > Windows Update.

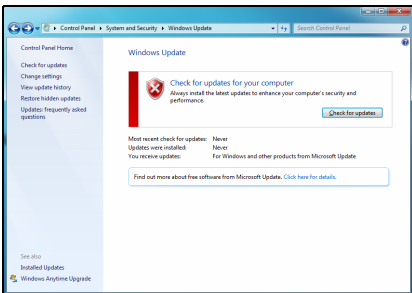

Windows Remote Assistance

Remote Assistance allows a Windows user to temporarily take over a remote Windows computer over a network or the internet to resolve issues. Remote Assistance makes it possible to diagnose and repair problems with a computer without personally visiting it.

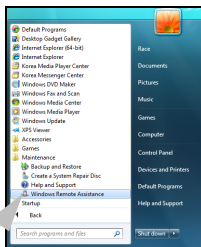

 Windows Remote Assistance

You can access Remote Assistance by clicking on **Start**  > **All Programs** > **Maintenance** > **Windows Remote Assistance**. Upon launching Remote Assistance, you will see a screen giving you the choice of either inviting someone to help you or offering to help someone.

RECOVERY

PACKARD BELL RECOVERY MANAGEMENT



Note: Packard Bell Recovery Management is only available with a preinstalled Windows operating system.

If your computer experiences problems that are not recoverable by other methods, you may need to reinstall the Windows operating system and factory-loaded software and drivers. To ensure you can recover your computer when needed, you should create a recovery backup as soon as possible.

Creating recovery discs

To reinstall using discs, you must create a set of recovery discs beforehand. Throughout the process, you will be guided by on-screen instructions. Please read them carefully!

1. Click on **Start**  > **All Programs** > **Packard Bell**, then click on **Packard Bell Recovery Management**.

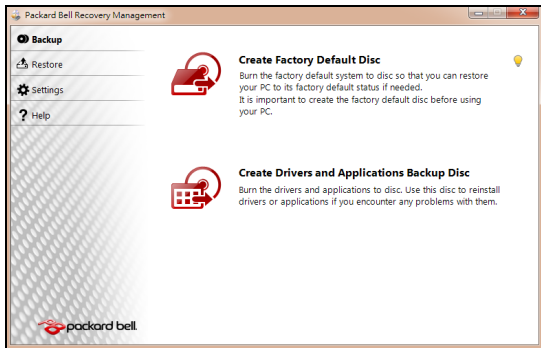

2. To create recovery discs for the hard drive's entire original contents, including Windows and all factory-loaded software and drivers, click **Create factory default disc**.

- OR -

To create recovery discs for only the factory-loaded software and drivers, click **Create driver and application backup disc**.

 **Important:** We recommend that you create each type of recovery disc as soon as possible.

The *Create Backup Disc* dialog box opens.

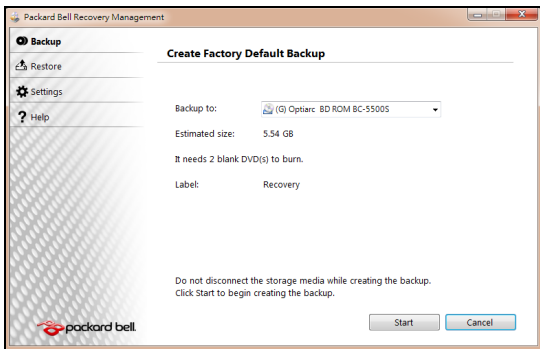

This dialog box tells you the number of blank, recordable discs you will need to complete the recovery discs. Make sure that you have the required number of identical, blank discs ready before continuing.

3. Insert a blank disc into the drive indicated in the *Backup to* list, then click **Next**. You will be shown the backup progress on the screen.

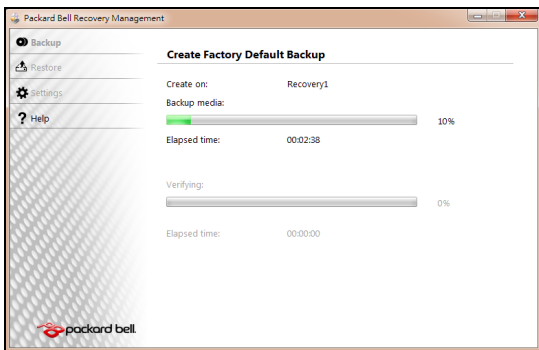

The drive ejects each disc as it completes burning it.

4. Remove the disc from the drive and mark it with a permanent marker.



Important: Write a unique, descriptive label on each disc, such as 'Windows Recovery Disc 1 of 2' or 'Apps/Drivers Recovery disc'.
Make sure you keep the discs in a safe place that you will remember.

5. If multiple discs are required, insert a new disc when prompted, then click **OK**. Continue until the process is complete.

RECOVERING YOUR SYSTEM

If Packard Bell support did not help fix your problem, you can use the *Packard Bell Recovery Management* program. This will restore your computer to the same state as when you purchased it, while giving you an option to retain all settings and personal data for later retrieval.

To recover your system:

1. Perform minor fixes.

If only one or two items of software or hardware have stopped working correctly, the problem may be solved by reinstalling the software or the device drivers.

To recover software and drivers that were pre-installed at the factory, see "*Recovering pre-installed software and drivers*" on page 86.

For instructions on reinstalling software and drivers that were not pre-installed, see that product's documentation or technical support Web site.

2. Revert to a previous system condition.

If reinstalling software or drivers does not help, then the problem may be solved by returning your system to a previous state when everything was working correctly.

For instructions, see "*Returning to a previous system condition*" on page 87.

3. Reset your system to its factory condition.

If nothing else has solved the problem and you want to reset your system to factory condition, see "*Returning your system to its factory condition*" on page 88.

Types of recovery

Recovering pre-installed software and drivers

As a troubleshooting step, you may need to reinstall the software and device drivers that came pre-installed on your computer from the factory. You can recover using either your hard drive or the backup you have created.

- New software - If you need to recover software that did not come pre-installed on your computer, you need to follow that software's installation instructions.
- New device drivers - If you need to recover device drivers that did not come pre-installed on your computer, follow the instructions provided with the device.

To recover your pre-installed software and drivers:

1. Click on **Start**  > **All Programs** > **Packard Bell**, then click on **Packard Bell Recovery Management**. *Packard Bell Recovery Management* opens.

- OR -

If you are recovering from your *driver and application recovery* backup, insert it into the disc drive, then go to Step 3 after the *Packard Bell Application Recovery* main menu opens.

2. Click on the *Restore* tab, then click **Reinstall Driver or Applications**. The *Packard Bell Application Recovery* main menu opens.

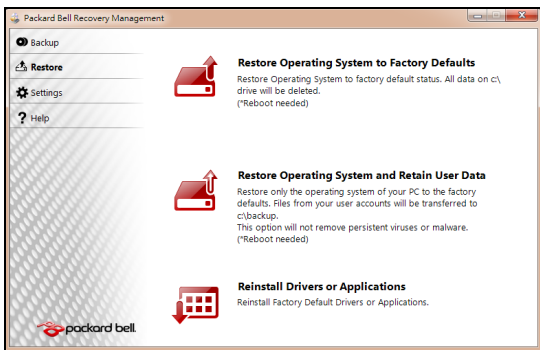

3. Click on **Contents**. A list of software and device drivers opens.
4. Click on the **install** icon for the item you want to install, then follow the on-screen prompts to complete the installation. Repeat this step for each item you want to reinstall.

Returning to a previous system condition

Microsoft System Restore periodically takes 'snapshots' of your system settings and saves them as restore points. In most cases of hard-to-resolve software problems, you can return to one of these restore points to get your system running again.

Windows automatically creates an additional restore point each day, and also each time you install software or device drivers.

 **Help:** For more information about using Microsoft System Restore, click **Start**, then click **Help and Support**. Type *windows system restore* in the Search Help box, then press **Enter**.

To return to a restore point:

1. Click on **Start**  > **Control Panel** > **System and Security** > **Action Center**, then click on **Recovery**.
2. Click on **Open System Restore**, then **Next**.
3. Click on the restore point you want, click on **Next**, then **Finish**. A confirmation message box appears.
4. Click on **Yes**. Your system is restored using the restore point you specified. This process may take several minutes, and may restart your computer.

Returning your system to its factory condition

If your computer experiences problems that are not recoverable by other methods, you may need to reinstall everything to return your system to its factory condition. You can reinstall using either your hard drive or the recovery discs you have created.

 **Caution:** This complete recovery deletes everything on your hard drive, then reinstalls Windows and all software and drivers that were pre-installed on your system. If you can access important files on your hard drive, back them up now.

- If you can still run Windows, see "*Recovering from within Windows*" below.

- If you cannot run Windows and your original hard drive is still working, see "*Recovering from the hard drive during startup*" on page 90.
- If you cannot run Windows and your original hard drive has been completely re-formatted or you have installed a replacement hard drive, see "*Recovering from your recovery discs*" on page 90.

Recovering from within Windows

To reinstall Windows and all pre-installed software and drivers:

1. Click on **Start**  > **All Programs** > **Packard Bell**, then click on **Packard Bell Recovery Management**. *Packard Bell Recovery Management* opens.
2. Click on the **Restore** tab, then **Restore system to factory default**. The *Confirm Restoration* dialog box opens.
3. Click on **Yes**, then **Start**. A dialog box displays information about the hard drive that the operating system will be recovered to.

 **Caution:** Continuing the process will erase all files on your hard drive.

4. Click on **OK**. The recovery process begins by restarting your computer, then continues by copying files to your hard drive. This process may take a while, but a Packard Bell Recovery Management screen shows you its progress.

When the recovery has finished, a dialog box prompts you to restart your computer.

5. Click on **OK**. Your computer restarts.

6. Follow the on-screen prompts for first-time system setup.

Recovering from the hard drive during startup

To reinstall Windows and all pre-installed software and drivers:

1. Turn on your computer, then press **Alt+F10** during startup. *Packard Bell Recovery Management* opens.
2. Click on **Restore system from factory default**.



Caution: Continuing the process will erase all files on your hard drive.

3. Click on **Next**. Your hard drive's original, factory-loaded contents are recovered. This process will take several minutes.

Recovering from your recovery discs

To reinstall Windows and all pre-installed software and drivers:

1. Turn on your computer, insert the first system recovery disc into your optical disc drive, then restart your computer.



Caution: Continuing the process will erase all files on your hard drive.

2. If it is not already enabled, you must enable the *F12 Boot Menu*.
 1. Press **F2** when starting your computer.
 2. Use the left or right arrow keys to select the **Main** menu.
 3. Press the down key until **F12 Boot Menu** is selected, press **F5** to change this setting to **Enabled**.
 4. Use the left or right arrow keys to select the **Exit** menu.

5. Select **Save Changes and Exit** and press **Enter**. Select **OK** to confirm.
6. Your computer will restart.
3. During startup, press **F12** to open the boot menu. The boot menu allows you to select which device to start from, such as the hard drive or an optical disc.
4. Use your arrow keys to select the line **CDROM/DVD** (this line may start with '**IDE 1...**'), then press **Enter**. Windows installs from the recovery disc you inserted.
5. Insert the second recovery disc when prompted, then follow the on-screen prompts to complete the recovery.

REGULATORY INFORMATION

CE COMPLIANCE REQUIREMENT

Products with the CE marking comply with both the Electromagnetic Compatibility Directive (2004/108/EC) and the Low Voltage Directive (2006/95/EC) issued by the Council of the European Communities.



Compliance with these directives implies conformity to the following European Standards:

EN55022: Radio disturbance characteristics

EN55024: Immunity characteristics

EN61000-3-2: Limitation of harmonic current emissions

EN61000-3-3: Limitation of voltage fluctuation and flicker in low-voltage supply system

EN60950-1: Product Safety. If your computer includes a telecommunication network board, the input/output socket is classified as Telecommunication Network Voltage (TNV-3).

Note for computers equipped with wireless controllers and wired modems:

Hereby, Packard Bell, declares that the wireless devices provided with this computer include a low power radio transmitter in full compliance with the essential requirements and other relevant provisions of Directive 1999/05/EC for Low Voltage, EMC and RF of the R&TTE.



List of applicable countries

This product must be used in strict accordance with the regulations and constraints in the country of use. For further information, contact the local office in the country of use. Please see <http://ec.europa.eu/enterprise/rte/implem.htm> for the latest country list.

MODIFICATIONS TO THE PRODUCT

CE Marking

Packard Bell cannot be held responsible for unauthorized modifications made by the user and the consequences thereof, which may alter the conformity of the product with the CE Marking.

Radio frequency interference

The manufacturer is not responsible for any radio or TV interference caused by unauthorised modifications to this equipment.

CONNECTIONS AND REMOTE EARTHS

PELV (Protected Extra Low Voltage)

To ensure the extra-low voltage integrity of the equipment, only connect equipment with mains-protected electrically-compatible circuits to the external ports.

SELV (Safety Extra Low Voltage)

Every input and output of this product is classified as Safety Extra Low Voltage.

Remote earths

To prevent electrical shock, connect all local (individual office) computers and computer support equipment to the same electrical circuit of the building wiring. If you are unsure, check the building wiring to avoid remote earth conditions.

Building supply

Only connect the equipment to a building supply that is in accordance with current wiring regulations in your country. In the U.K., these are the IEE regulations.

POWER SUPPLY AND CABLES

Power supply

The power supply socket-inlet and socket-outlet (if equipped) are classified as Hazardous Voltage.

You must unplug the power supply cord to disconnect the equipment from the power supply. In that aim, the socket-outlet should be installed near to the equipment and should be easily accessible.

Under no circumstances should the user attempt to disassemble the power supply. The power supply has no user-replaceable parts. Inside the power supply are hazardous voltages that can cause serious personal injury.

A defective power supply must be returned to your dealer.

Power cables and plug

This Product requires a three-wire grounded power cord and plug. The plug only fits in a grounded power outlet. Make sure the power outlet is properly grounded before inserting the plug. Do not insert the plug into a non-grounded power outlet. Contact your electrician for details.

The cord length must not exceed 2.5 metres. To prevent electrical hazards, do not remove or disable the ground contact on the power cord. Replace the power cord if it gets damaged. Contact your dealer for an exact replacement. In Europe, the plug must be rated for 250 VAC, 10 amp minimum. The plug must display an international agency approval marking. The cord must be suitable for use in the end-user country. Consult your dealer or the local electrical authorities if you are unsure of the type of power cord to use in your country.

Cables

For cables which are not delivered with the Product in the computer's packaging: The EMC performance of the system is guaranteed only if the cable and interface use efficient shielding.

The use of shielded interface cable is required for USB, IEEE1394, serial, printer, game, analog or digital audio/ video, PS2, TV or FM antennas, and generally all high-speed cable interfaces.

Use only UL Listed No. 26AWG or larger telecommunication cords.

Only Ethernet LAN or RTC modem cable can have length exceeding 3 metres.

Packard Bell recommends that you add a ferrite core round clip to each cable connecting your computer to a hardware device that was not included with your computer.

- Ferrite reference: 28A-2029 from Steward (two loops)

During product certification, Packard Bell used the following cable quality:

- USB2.0 Certified Cables from Hama 46778
- IEEE1394 shielded FireWire from Hama 50011
- RCA-RCA shielded Audio/Video Cables from Thomson KHC001M, KHC012M, KHC028M
- Stereo Jack shielded Audio cables from Hama 43330H, 42714H

CHASSIS COVER REMOVAL AND REPLACEMENT

Before removing the chassis cover to service or modify the equipment, you must disconnect all power and modem cords.

Caution: Some components inside the computer can become hot after prolonged use.

You then must close the chassis before you plug in and switch on the equipment.

LASER COMPLIANCE STATEMENT

The optical devices are tested and certified to be compliant with International Electrotechnical Commission IEC60825-1 and European EN60825-1 standards for Class 1 laser products.

Class 1 laser products are not considered hazardous. The optical devices are designed such that there is never human access to laser radiation above a Class 1 level during normal operation or prescribed maintenance conditions.

The optical devices installed in your computer are designed for use solely as components of such electronic product and therefore do not comply with the appropriate requirements of Code of Federal Regulation Sec. 1040.10 and Sec. 1040.11 for COMPLETE laser products.

Because exposure to laser radiation is extremely hazardous, under no circumstances should the user attempt to disassemble the laser device.

PACKAGING

The packaging of this product is compliant with the European Environmental Directive 94/62/EC from December 20 th 1994 and its equivalent in the French Legislation by the Decree 98-638 from July 20 th 1998.

COMPLIANT WITH RUSSIAN REGULATORY CERTIFICATION



ME61

ENVIRONMENT

OUR COMMITMENT TO ENVIRONMENTAL PROTECTION

Environment has been at the heart of our products.

Packard Bell is committed to limit the environmental impact of its products during product lifecycle.

Starting at design phase, with a very strict procurement policy, maximum attention is given to electronic components in order to limit their weight in heavy metals such as lead, cadmium, chromium, mercury, etc. Suppliers are asked, for each part of any product, to respect all regulations.

As far as end-of-life products are concerned, measures have been taken to anticipate and facilitate the recycling of all our products. Thus, all plastic parts heavier than 25 grams used in Packard Bell products are labelled ISO 11469. This label allows a quick recognition of the material and eases its valorisation. Likewise, desktop computers are designed to be easily dismantled, with screws being replaced by clips.

PRODUCT DISPOSAL

The 2002/96/EC Directive, known as Waste Electrical and Electronic Equipment (WEEE) Directive, requires that used electrical and electronic products must be disposed of separately from normal household waste in order to promote reuse, recycling and other forms of recovery and to reduce the quantity of waste to be eliminated with a view to reducing landfill and incineration. The crossed-out dustbin logo is there to remind you that these products must be sorted separately for disposal. These rules concern all Packard Bell products and also all accessories, such as keyboard, mouse, speakers, remote control, etc. When you have to dispose of such products, make sure that they are correctly recycled by checking with your local authority, or by returning your old equipment to your retailer if you are replacing it. For information, visit www.packardbell.com/recycling.



Battery disposal (when applicable)

Before disposing of your equipment ensure that you have removed any batteries that may be fitted in the equipment. European law states that batteries must be collected for disposal separately from household waste. Do not throw your used batteries in the dustbin. Dispose of your used batteries via a battery collection scheme where available, or ask your distributor or local authority what infrastructures you can use. Your efforts will enable the safe collection, recycling and destruction of used batteries and will help protect the environment and reduce health hazards.



Caution: Risk of explosion if battery is replaced by an incorrect type. Dispose of used batteries according to the instructions.

Mercury advisory

For electronic products containing a non-LED-backlit LCD/CRT monitor or display: Lamp(s) inside this product contain mercury and must be recycled or disposed of according to local, state or federal laws. For more information, contact the Electronic Industries Alliance at www.eiae.org. for lamp-specific disposal information, check www.lamprecycle.org.



SOFTWARE LICENSE



Note: *Most of the software applications are already preinstalled on your Packard Bell computer. They are ready to use or to set up. However, some titles require a CD or DVD to run. You will find these discs in your computer's packaging.*

Packard Bell License Agreement (CD and/or DVD Products). This copy of the original is your proof of license. Please treat it as valuable property.

Important!

Read carefully before installing the software.

The following License Agreement applies to you. This is a legal agreement between you (either individual or an entity) and Packard Bell. By installing the software you are agreeing to be bound by the terms of this Agreement. If you do not agree to the terms of this Agreement, promptly return your entire computer system, the unopened software packet(s), if any, as well as the accompanying terms (including written materials or other container(s)) in the place you obtained them for a full refund.

PACKARD BELL SOFTWARE LICENSE

1. Grant of License

This Packard Bell License Agreement (“License”) permits you to use one copy of the specified version of the Packard Bell SOFTWARE identified above (which may include at least one CD or DVD disc) on any single computer, provided the SOFTWARE is in use on only one computer at any time. If you have multiple Licenses for the SOFTWARE, then at any time you may have as many copies of the SOFTWARE in use as you have Licenses. The SOFTWARE is “in use” on a computer when it is loaded into the temporary memory (i.e. RAM) or installed in the permanent memory (e.g. hard disk, CD and/or DVD, or other storage device of that computer, except that a copy installed on a network server for the sole purpose of distribution of other computer

is not “in use.” If the anticipated number of users of the SOFTWARE will exceed the number of applicable Licenses, then you must have a reasonable mechanism or process in place to assure that the number of persons using the SOFTWARE concurrently does not exceed the number of Licenses. If the SOFTWARE is permanently installed on the hard disk or the storage device of a computer (other than a network server) and one person uses that computer more than 80% of the time it is in use, then that person may also use the SOFTWARE on a portable or home computer.

2. Copyright

The SOFTWARE is owned by Packard Bell or its suppliers and is protected by United States copyright laws and international treaty provision. Therefore, you must treat the SOFTWARE like any other copyrighted material (e.g. a book or musical recording) except that you may transfer the CD and/or DVD disc portion of the SOFTWARE, if any, to a single hard disk provided you keep the original solely for backup or archival purposes. You may not copy the CD and/or DVD disc portion of the SOFTWARE or the written materials accompanying the SOFTWARE.

3. Other restrictions

You may not rent or lease the SOFTWARE, but you may transfer the SOFTWARE and accompanying written materials on a permanent basis provided you retain no copies and the recipient agrees to the terms of this Agreement. You may not reverse engineer, decompile or disassemble the SOFTWARE. Any transfer of the SOFTWARE must include the most recent update and all prior versions.

THIRD PARTY SOFTWARE OR FREE SOFTWARE LICENSE INFORMATION

Software pre-loaded, embedded or otherwise distributed with the products provided by Packard Bell does contain free or third party software programs (the “Free Software”), which are licensed under the terms GNU General Public License (the “GPL”). The Free Software is marked as such. Your copying, distribution and/or modification of the Free Software shall be subject to the terms of the GPL.

The Free Software is distributed in the hope that, but it will be useful WITHOUT ANY WARRANTY; without even the implied warranty of MERCHANTABILITY or FITNESS FOR A PARTICULAR PURPOSE. The provisions of the GNU General Public License shall always apply. You may access <http://www.gnu.org> directly to obtain a copy of the GPL or write to the free Software Foundation, Inc. and request a copy. The address of the Free Software Foundation, Inc is: 59 Temple Place - Suite 330, Boston, MA, 02111-1307, USA.

For a period of three (3) years as commencing from your receipt of this software, you may obtain a complete machine-readable copy of the source code for the Free Software under the terms of the GPL without charge except for the cost of media, shipping, and handling, upon a written request to us.

Contact us if you have any further questions. Our mailing address is 8F, 88, Sec. 1, Hsin Tai Wu Rd., Hsichih, Taipei Hsien 221, Taiwan.

INDEX

A

Audio CDs 40 Autoplay 42

B

Batteries 98 maximizing life 32
battery disposal 98 optimizing 35
battery pack removing 34
 battery-low warning 35 using the first time 32
 characteristics 31 Blu-ray 41
 charging 34 brightness
 checking charge level 35 hotkeys 18
 installing 34 Browser 55
 low conditions 36

C

Cables 9, 93 features 13
charging on indicator 16
 checking level 35 Computer environment 8
Cleaning your computer 10 connections
Codec 43 network 26
computer

D

Disk Cleanup 72 Download 42
Disk Defragmenter 73 Drives
Display Memory card reader 25
 hotkeys 17 DSL 51
Documentation DVD 43
 Packard Bell Website 57 DVD movies

| | | | |
|------------------------------------|--------|---------------------------------------|--------|
| playing..... | 43 | | |
| E | | | |
| Electronic Program Guide | 41 | Epilepsy warning | 12 |
| Environment..... | 97 | Error checking..... | 71 |
| F | | | |
| Firewall | 59, 67 | front view | 20 |
| H | | | |
| HDD (Hard Disk Drive) | | Health precautions..... | 11 |
| Free space..... | 72 | Helpdesk..... | 71 |
| Management..... | 74 | hotkeys | 19 |
| I | | | |
| Interference | 93 | Firewall | 59, 67 |
| Internet | | Internet Service Provider (ISP) | 50 |
| Connection | 50, 51 | | |
| K | | | |
| Keyboard | | hotkeys..... | 19 |
| L | | | |
| LAN (Local Area Network)..... | 52 | left view..... | 20 |
| Last Known Good Configuration..... | 78 | | |
| M | | | |
| Maintenance | | Malware..... | 59 |
| HDD management | 74 | Memory card reader..... | 25 |
| Recovery Management Program..... | 38, 81 | Modem | 51 |
| System tools | 75 | Multimedia files..... | 40 |

N

| | | | |
|--------------------------|----|-------------------------------|-------|
| network..... | 26 | Norton Internet Security..... | 57,62 |
| Network connections..... | 52 | | |

P

| | | | |
|---------------------------------|--------|------------------|----|
| Packard Bell | | Website..... | 57 |
| Packard Bell Updater..... | 39 | ports..... | 25 |
| Recovery Management Program.... | 38, 81 | Power cords..... | 9 |
| | | PowerDVD..... | 41 |

R

| | | | |
|---------------------------------|--------|------------------------------|----|
| Recovery | | Removable media devices..... | 26 |
| Recovery Management Program.... | 38, 81 | Removing hardware..... | 26 |
| System Restore..... | 76 | Removing software..... | 74 |
| Regulatory Information..... | 92,97 | Restore points..... | 77 |

S

| | | | |
|----------------------------|-------|-----------------------------|-------|
| Safe Computing..... | 71 | hotkey..... | 17,18 |
| Safety precautions..... | 8 | Spyware..... | 58 |
| Security | | Support | |
| Antivirus..... | 60 | Packard Bell Website..... | 57 |
| Updates..... | 68,78 | System Restore..... | 76 |
| Windows Action Center..... | 66,78 | System tools | |
| Software | | Disk Cleanup..... | 72 |
| Removing software..... | 74 | Disk Defragmenter..... | 73 |
| Software License..... | 99 | Error checking..... | 71 |
| speakers | | Windows System Restore..... | 76 |

T

| | |
|---------------|----|
| TV tuner..... | 40 |
|---------------|----|

U

| | | | |
|----------------------------|----|---------------------------------|-------|
| Uninstalling hardware..... | 26 | Windows automatic updates | 68,79 |
| universal serial bus | 27 | User Account Control | 69 |
| Update | | | |

V

| | | | |
|------------|----|------------|----|
| view | | rear | 20 |
| front..... | 21 | right..... | 22 |
| left | 21 | | |

W

| | | | |
|----------------------|----|---------------------------------|-------|
| Warranty..... | 7 | Windows Action Center | 66,78 |
| Welcome Center | 37 | Windows automatic updates | 68,79 |
| WiFi..... | 52 | Windows Defender | 68 |
| Windows | | Windows Media Center | 40 |
| System Restore | 76 | Windows Media Player | 40 |
| Using Windows | 37 | Windows Remote Assistance | 80 |
| Welcome Center | 37 | | |