

HP Compaq 6530b Notebook PC and
HP Compaq 6535b Notebook PC
Maintenance and Service Guide



© Copyright 2008 Hewlett-Packard
Development Company, L.P.

AMD Athlon, AMD Sempron,
and AMD Turion are trademarks of
Advanced Micro Devices, Inc. Bluetooth is a
trademark owned by its proprietor and used
by Hewlett-Packard Company under license.
Intel and Core are trademarks of
Intel Corporation in the U.S. and
other countries. Microsoft, Windows,
and Windows Vista are U.S. registered
trademarks of Microsoft Corporation.
SD Logo is a trademark of its proprietor.

The information contained herein is subject
to change without notice. The only
warranties for HP products and services are
set forth in the express warranty statements
accompanying such products and services.
Nothing herein should be construed as
constituting an additional warranty. HP shall
not be liable for technical or editorial errors
or omissions contained herein.

First Edition: June 2008

Document Part Number: 486471-001

Safety warning notice

-
- ⚠ **WARNING!** To reduce the possibility of heat-related injuries or of overheating the computer, do not place the computer directly on your lap or obstruct the computer air vents. Use the computer only on a hard, flat surface. Do not allow another hard surface, such as an adjoining optional printer, or a soft surface, such as pillows or rugs or clothing, to block airflow. Also, do not allow the AC adapter to contact the skin or a soft surface, such as pillows or rugs or clothing, during operation. The computer and the AC adapter comply with the user-accessible surface temperature limits defined by the International Standard for Safety of Information Technology Equipment (IEC 60950).
-

Table of contents

1 Product description

2 External component identification

Top components	9
Display components	9
Buttons, switches, and fingerprint reader	10
Keys	12
TouchPad	13
Front components	14
Right-side components	15
Left-side components	16
Rear components	17
Bottom components	18

3 Illustrated parts catalog

Service tag	19
Computer major components	21
Plastics Kit	28
Cable Kit	29
Mass storage devices	30
Miscellaneous parts	31
Sequential part number listing	32

4 Removal and replacement procedures

Preliminary replacement requirements	38
Tools required	38
Service considerations	38
Plastic parts	38
Cables and connectors	39
Drive handling	39
Grounding guidelines	40
Electrostatic discharge damage	40
Packaging and transporting guidelines	41
Workstation guidelines	41

Equipment guidelines	42
Unknown user password	43
Component replacement procedures	44
Service tag	44
Computer feet	45
Battery	46
SIM	47
Display inverter	48
Bluetooth module	50
Hard drive	52
RTC battery	54
Optical drive	55
WLAN module	57
Expansion memory module	59
Keyboard	61
Primary memory module	63
WWAN module	64
Switch cover	65
Fan	66
Heat sink	68
Processor	72
Display assembly	74
Top cover	81
TouchPad board	83
ExpressCard board	86
Audio board	87
Modem module	89
Speaker	91
USB/digital media board	92
Rear cover	93
SIM connector board	95
Modem module cable	96
Bluetooth module cable	97
System board	99
Microphone extension cable	102

5 Computer Setup

Starting Computer Setup	103
Using Computer Setup	103
Navigating and selecting in Computer Setup	103
Restoring factory settings in Computer Setup	104
Computer Setup Menus	105
File menu	105

Security menu	105
Diagnostics menu	106
System Configuration menu	106

6 Specifications

Computer specifications	109
14.1-inch, WXGA display specifications	110
Hard drive specifications	111
DVD±RW and CD-RW Double-Layer Combo Drive specifications	112
DVD/CD-RW Combo Drive specifications	113
DVD-ROM Drive	114
System DMA specifications	115
System interrupt specifications	116
System I/O address specifications	117
System memory map specifications	119

7 Screw listing

Phillips PM2.0×5.0 captive screw	121
Phillips PM2.5×10.0 captive screw	122
Phillips PM3.0×4.0 screw	123
Phillips PM2.5×9.0 captive screw	124
Phillips PM2.0×3.0 screw	124
Phillips PM2.5×4.0 screw	127
Phillips PM2.5×4.0 screw	128
Phillips PM2.0×5.0 screw	129
Phillips PM2.5×7.0 captive screw	131
Phillips PM2.0×4.0 captive screw	132
Torx8 T8M2.5×9.0 screw	134
Torx8 T8M2.5×6.0 screw	136
Phillips PM2.5×3.0 broad-head screw	137
Phillips PM2.5×5.0 screw	139
Phillips PM2.5×3.0 screw	141
Hex HM5.0×9.0 screw lock	142

8 Backup and recovery

Overview	143
Backing up	144
Backup tips	144
Backing up your information	144
Performing a recovery	145
Recovering the hard drive using f11	145
Recovering information using a Windows Vista operating system DVD (purchased separately)	146

9 Connector pin assignments

1394	148
Audio-in (microphone)	148
Audio-out (headphone)	148
External monitor	149
RJ-11 (modem)	150
RJ-45 (network)	151
S-Video-out	152
Serial port	153
Universal Serial Bus	153

10 Power cord set requirements

Requirements for all countries and regions	154
Requirements for specific countries and regions	155

11 Recycling

Battery	156
Display	156

Index	162
--------------------	------------

1 Product description

Category	Description	HP Compaq 6530b Notebook PC with WWAN	HP Compaq 6530b Notebook PC without WWAN	HP Compaq 6535b Notebook PC with WWAN	HP Compaq 6535b Notebook PC without WWAN
Product Name	HP Compaq 6530b Notebook PC	√	√		
	HP Compaq 6535b Notebook PC			√	√
Processors	<ul style="list-style-type: none"> Intel® Core™ 2 Duo T9600 2.80-GHz processor, 35W, 6-MB L2 cache, 800-MHz front side bus (FSB) 	√	√		
	<ul style="list-style-type: none"> Intel Core 2 Duo P9500 2.53-GHz processor, 25W, 6-MB L2 cache, 800-MHz FSB 	√	√		
	<ul style="list-style-type: none"> Intel Core 2 Duo T9400 2.53-GHz processor, 35W, 3-MB L2 cache, 800-MHz FSB 	√	√		
	<ul style="list-style-type: none"> Intel Core 2 Duo P8600 2.40-GHz processor, 25W, 3-MB L2 cache, 800-MHz FSB 	√	√		
	<ul style="list-style-type: none"> Intel Core 2 Duo P8400 2.26-GHz processor, 25W, 3-MB L2 cache, 800-MHz FSB 	√	√		
	<ul style="list-style-type: none"> AMD® Turion™ X2 Ultra Dual Core ZM-86 2.40-GHz processor, 35W, 2-MB L2 cache 			√	√
	<ul style="list-style-type: none"> AMD Turion X2 Ultra Dual Core ZM-82 2.20-GHz processor, 35W, 2-MB L2 cache 			√	√

Category	Description	HP Compaq 6530b Notebook PC with WWAN	HP Compaq 6530b Notebook PC without WWAN	HP Compaq 6535b Notebook PC with WWAN	HP Compaq 6535b Notebook PC without WWAN
	<ul style="list-style-type: none"> AMD Turion X2 Ultra Dual Core ZM-80 2.10-GHz processor, 35W 2-MB L2 cache 			√	√
	<ul style="list-style-type: none"> AMD Turion X2 Dual Core RM-70 2.00-GHz processor, 35W, 1-MB L2 cache 			√	√
	<ul style="list-style-type: none"> AMD Athlon™ X2 QL-60 1.90-GHz processor, 35W, 1-MB L2 cache 			√	√
	<ul style="list-style-type: none"> AMD Sempron™ SI-40 2.00-GHz processor, 25W, 512-KB L2 cache 			√	√
Chipset	<ul style="list-style-type: none"> Northbridge: GE45 Southbridge: ICH9M 	√	√		
	<ul style="list-style-type: none"> Northbridge: M780G Southbridge: SB700 			√	√
Graphics	Mobile Intel® Graphics Media Accelerator 4500MHD	√	√		
	Intel Universal Memory Architecture (UMA) graphics subsystem integrated with shared video memory (dynamically allocated)	√	√		
	ATI Radeon HD 3200 Graphics			√	√
	UMA graphics subsystem integrated with shared video memory (dynamically allocated)			√	√
Panels	All display assemblies include 2 wireless local area network (WLAN) antennae	√	√	√	√
	<ul style="list-style-type: none"> 14.1-inch WXGA BrightView 14.1-inch WXGA+ 14.1-inch WXGA 	√	√	√	√
Memory	2 customer-accessible/upgradable memory module slots	√	√	√	√

Category	Description	HP Compaq 6530b Notebook PC with WWAN	HP Compaq 6530b Notebook PC without WWAN	HP Compaq 6535b Notebook PC with WWAN	HP Compaq 6535b Notebook PC without WWAN
	Supports dual-channel memory	√	√	√	√
	Supports up to 4 GB of system RAM	√	√	√	√
	PC2-6400, 800-MHz, DDR2	√	√	√	√
	Supports the following configurations:	√	√	√	√
	<ul style="list-style-type: none"> • 8192-MB total system memory (4096 × 2, dual-channel) • 4096-MB total system memory (4096 × 1) • 4096-MB total system memory (2048 × 2, dual-channel) • 3072-MB total system memory (2048 + 1024, dual-channel) • 2560-MB total system memory (2048 + 512, dual-channel) • 2048-MB total system memory (2048 × 1) • 2048-MB total system memory (1024 × 2, dual-channel) • 1536-MB total system memory (1024 + 512, dual-channel) • 1024-MB total system memory (1024 × 1) 				
Hard drives	Supports 9.5-mm, 2.5-inch hard drives	√	√	√	√
	Customer-accessible	√	√	√	√
	Serial ATA	√	√	√	√

Category	Description	HP Compaq 6530b Notebook PC with WWAN	HP Compaq 6530b Notebook PC without WWAN	HP Compaq 6535b Notebook PC with WWAN	HP Compaq 6535b Notebook PC without WWAN
	Supports the following drives: <ul style="list-style-type: none"> • 250-GB, 5400-rpm • 160-GB, 5400-rpm • 120-GB, 7200-rpm • 120-GB, 5400-rpm 	√	√	√	√
Optical drives	Fixed (loosening of 1 screw required)	√	√	√	√
	Customer-accessible	√	√	√	√
	Parallel ATA	√	√	√	√
	12.7-mm tray load	√	√	√	√
	Supports the following drives: <ul style="list-style-type: none"> • DVD±RW and CD-RW SuperMulti Double-Layer Combo Drive with LightScribe • DVD/CD-RW Combo Drive • DVD-ROM Drive 	√	√	√	√
Diskette drive	Supports external USB diskette drive only	√	√	√	√
	Supports boot from external USB diskette drive	√	√	√	√
	Supports 3-mode diskette drive	√	√	√	√
Audio	High-definition audio 1984A - HD	√	√	√	√
	Integrated stereo microphone	√	√	√	√
	Integrated dual array microphone with camera only	√	√	√	√
	Integrated VGA camera	√	√	√	√
	Stereo speakers (2)	√	√	√	√
Modem	No-modem option available in Japan only	√	√	√	√

Category	Description	HP Compaq 6530b Notebook PC with WWAN	HP Compaq 6530b Notebook PC without WWAN	HP Compaq 6535b Notebook PC with WWAN	HP Compaq 6535b Notebook PC without WWAN
	56K V.92 1.5-inch data/fax modem with digital line guard	√	√	√	√
Ethernet	Low-cost 10/100/1000 Ethernet network interface card (NIC)	√	√	√	√
	NIC Power Down Technology	√	√	√	√
	S4/S5 wake on local area network (LAN) on AC power	√	√	√	√
	Power Down Technology S4/S5 wake on LAN (on/AC)	√	√	√	√
Wireless	Integrated WLAN options by way of wireless module:				
	Support for no WLAN option	√			
	Intel 802.11a/b/g/n (not available with Linux operating system)	√			
	Intel 802.11a/b/g	√	√		
	Intel 802.11b/g	√	√		
	Integrated WLAN options by way of wireless module:				
	Wireless wide area network (WWAN) module	√			
	Subscriber identity module (SIM) user-accessible inside the battery bay	√			
	Integrated personal area network (PAN) options by way of Bluetooth® module:				
	No-WPAN option available	√	√		
	Broadcom Bluetooth 2.0 +EDR	√	√		
External media card	One ExpressCard/54 slot	√	√	√	√
	Media Card Reader supporting Memory Stick, Memory Stick Pro, MultiMediaCard, MultiMediaCard Plus, Secure Digital Memory Card, Secure Digital High Capacity Memory Card, xD-Picture Card, xD-	√	√	√	√

Category	Description	HP Compaq 6530b Notebook PC with WWAN	HP Compaq 6530b Notebook PC without WWAN	HP Compaq 6535b Notebook PC with WWAN	HP Compaq 6535b Notebook PC without WWAN
	Picture Card Type H, and xD-Picture Card Type M				
Ports	<ul style="list-style-type: none"> • Audio-in (stereo microphone) • Audio-out (stereo headphone) • Docking • RJ-11 (modem) • RJ-45 (Ethernet, includes link and activity lights) • Serial • S-Video-out (7 pin) • Travel battery • USB (4) • VGA (Dsub 15-pin) supporting 1600 × 1200 external resolution at 75-GHz (hot plug/unplug with auto-detect) • 1394a • 3-pin HP Smart AC Adapter 	√	√	√	√
Docking	Support for HP 3-in-1 NAS Docking Station, HP Advanced Docking Station, and HP Docking Station	√	√	√	√
Keyboard/ pointing devices	31.20-mm (12.28-inch) keyboard with embedded numeric keypad	√	√	√	√
	TouchPad only, with 2 TouchPad buttons and vertical scrolling (taps enabled as default)	√	√	√	√
	Touch-sensitive controls	√	√	√	√
	Spill-resistant	√	√	√	√
Power requirements	90-W HP Smart AC Adapter with localized cable plug support (2-wire plug with ground pin, supports 2-pin DC	√	√	√	√

Category	Description	HP Compaq 6530b Notebook PC with WWAN	HP Compaq 6530b Notebook PC without WWAN	HP Compaq 6535b Notebook PC with WWAN	HP Compaq 6535b Notebook PC without WWAN
	connector) and HP Fast Charge Technology				
	6-cell, 55-Wh Li-ion battery	√	√	√	√
	6-cell, 47-Wh Li-ion battery	√	√	√	√
	Support for 8-cell Li-ion Extended Life Battery and 12-cell Ultra Capacity Battery	√	√	√	√
Security	Supports Kensington security lock	√	√	√	√
	Trusted platform module (TPM) v. 1.2	√	√	√	√
	Enhanced Drive Lock	√	√	√	√
	Fingerprint reader	√	√	√	√
	Integrated smart card reader	√	√	√	√
Operating system	Preinstalled:	√	√	√	√
	<ul style="list-style-type: none"> Windows Vista® 32 Home Basic Windows Vista Business 32 Windows Vista Business 32 (with Windows® XP Pro images) FreeDOS Red Flag Linux 				
	Restore media:	√	√	√	√
	<ul style="list-style-type: none"> Windows Vista 32 Home Basic Windows Vista Business 32 Windows Vista Business 64 Windows Vista Ultimate Windows XP Pro, Service Pack 2 				

Category	Description	HP Compaq 6530b Notebook PC with WWAN	HP Compaq 6530b Notebook PC without WWAN	HP Compaq 6535b Notebook PC with WWAN	HP Compaq 6535b Notebook PC without WWAN
	<ul style="list-style-type: none"> Windows Vista (DRDVD) Windows XP Pro (DRDVD) 				
	Certified: <ul style="list-style-type: none"> Microsoft WHQL SuSE Linux 	√	√	√	√
	Web support: <ul style="list-style-type: none"> Windows XP Pro Windows Vista Enterprise 	√	√	√	√
Serviceability	End-user replaceable parts: <ul style="list-style-type: none"> AC adapter Battery (system) Hard drive Memory modules (expansion and primary) Optical drive SIM WLAN module WWAN module 	√	√	√	√

2 External component identification

Top components

Display components



Item	Component	Function
(1)	WLAN antenna locations	Send and receive signals from one or more WLAN devices. These antennae are not visible from the outside of the computer.
(2)	Internal microphones (2) (select models only)	Record sound. NOTE: Some models have one internal microphone.
(3)	WWAN antenna locations (select models only)	Send and receive signals from one or more WWAN devices. These antennae are not visible from the outside of the computer.

Item	Component	Function
(4)	Webcam light (select models only)	On: The integrated camera is in use.
(5)	HP Webcam (select models only)	Records audio and video and captures still photographs.

Buttons, switches, and fingerprint reader



Item	Component	Function
(1)	Fingerprint reader (select models only)	Allows a fingerprint logon to Windows, instead of a password logon.
(2)	Power button	<ul style="list-style-type: none"> When the computer is off, press the button to turn on the computer. When the computer is on, press the button to initiate Hibernation. When the computer is in Hibernation, press the button briefly to exit Hibernation. When the computer is in the Sleep state, press the button briefly to exit Sleep. <p>If the computer has stopped responding and Windows® shutdown procedures are ineffective, press and hold the power button for at least 5 seconds to turn off the computer.</p> <p>To learn more about your power settings, select Start > Control Panel > System and Maintenance > Power Options.</p>
(3)	Internal display switch	Turns off the display if the display is closed while the power is on.

Item	Component	Function
(4)	Info button	<p>Launches Info Center, which provides shortcuts, such as the following:</p> <ul style="list-style-type: none"> • HP 3D DriveGuard—Controls settings for software that protects the hard drive by parking the drive when the computer is dropped or moved. • HP Software Setup—Installs preloaded programs to make them accessible to the user. • HP Wireless Assistant—Turns wireless devices on or off. <p>NOTE: If a wireless device is disabled in Computer Setup, it must first be reenabled in Computer Setup before it can be turned on or off using Wireless Assistant.</p> <ul style="list-style-type: none"> • System Information—Describes the memory, processor speed, BIOS (basic input-output system) and other essential information about your computer system. <p>NOTE: Click the Advanced button to see more information about your system.</p> <ul style="list-style-type: none"> • User Guides—Provide specific details about the computer, including your components, power, drives, multimedia, security, and wireless features. <p>NOTE: After you configure QuickLook 2, you can open this feature by pressing the info button when the computer is off or in Hibernation.</p>
(5)	Presentation button	<p>Opens the Presentation Options window, where you can start a frequently used presentation, file, program, or Web site. You can also adjust display settings for optimum viewing.</p>
(6)	Wireless button	<p>Turns the wireless feature on or off but does not establish a wireless connection.</p> <p>NOTE: You must set up or access a wireless network to establish a wireless connection.</p>
(7)	Volume mute button	<p>Mutes and restores speaker sound.</p>
(8)	Volume scroll zone	<p>Adjusts speaker volume. Slide your finger to the left to decrease volume and to the right to increase volume.</p>

Keys

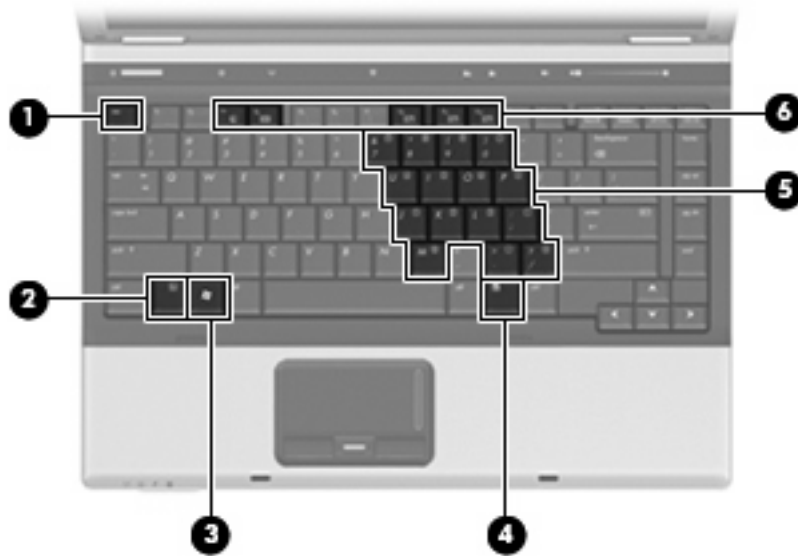

Item	Component	Function
(1)	esc key	Displays system information when pressed in combination with the fn key.
(2)	fn key	Executes frequently used system functions when pressed in combination with a function key or the esc key.
(3)	Windows logo key	Displays the Windows Start menu.
(4)	Windows applications key	Displays a shortcut menu for items beneath the pointer.
(5)	Embedded numeric keypad keys	Can be used like the keys on an external numeric keypad.
(6)	Function keys	Execute frequently used system functions when pressed in combination with the fn key.

TouchPad

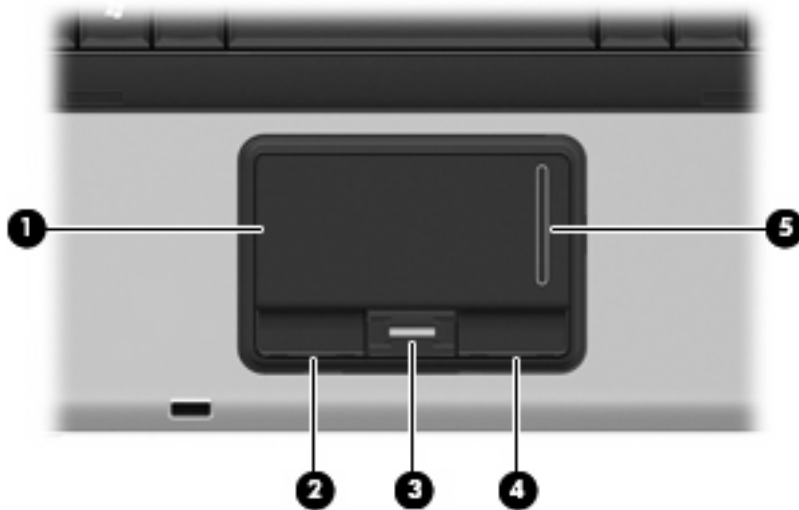

Item	Component	Function
(1)	TouchPad*	Moves the pointer and selects or activates items on the screen.
(2)	Left TouchPad button*	Functions like the left button on an external mouse.
(3)	Fingerprint reader (select models only)	Allows a fingerprint logon to Windows, instead of a password logon.
(4)	Right TouchPad button*	Functions like the right button on an external mouse.
(5)	TouchPad scroll zone	Scrolls up or down.

*This table describes factory settings. To view or change pointing device preferences, select **Start > Control Panel > Hardware and Sound > Mouse**.

Front components

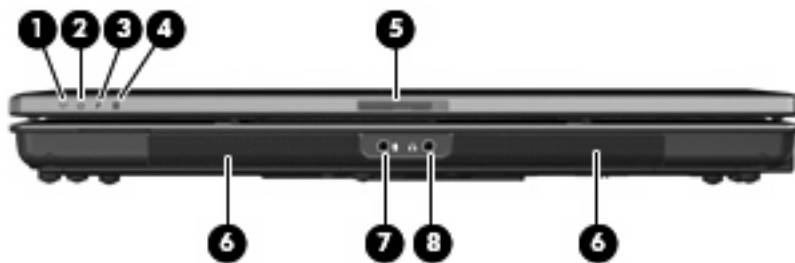

Item	Component	Function
(1)	Wireless light	<ul style="list-style-type: none"> Blue: An integrated wireless device, such as a wireless local area network (WLAN) device, an HP Broadband Wireless Module, and/or a Bluetooth device, is on. Amber: All wireless devices are off.
(2)	Power light	<ul style="list-style-type: none"> On: The computer is on. Blinking: The computer is in the Sleep state. Blinking rapidly: An AC adapter with a higher power rating should be connected. Off: The computer is off or in Hibernation.
(3)	Battery light	<ul style="list-style-type: none"> Amber: A battery is charging. Turquoise: A battery is close to full charge capacity. Blinking amber: A battery that is the only available power source has reached a low battery level. When the battery reaches a critical battery level, the battery light begins blinking rapidly. Off: If the computer is plugged into an external power source, the light turns off when all batteries in the computer are fully charged. If the computer is not plugged into an external power source, the light stays off until the battery reaches a low battery level.
(4)	Drive light	<ul style="list-style-type: none"> Blinking: The hard drive or optical drive is being accessed. Amber (select models only): HP 3D DriveGuard has temporarily parked the hard drive.
(5)	Display release latch	Opens the computer.
(6)	Speakers (2)	Produce sound.
(7)	Audio-out (headphone) jack	<p>Produces sound when connected to optional powered stereo speakers, headphones, ear buds, a headset, or television audio.</p> <p>NOTE: When a device is connected to the headphone jack, the computer speakers are disabled.</p>
(8)	Audio-in (microphone) jack	Connects an optional computer headset microphone, stereo array microphone, or monaural microphone.

Right-side components

 **NOTE:** Refer to the illustration that most closely matches your computer.

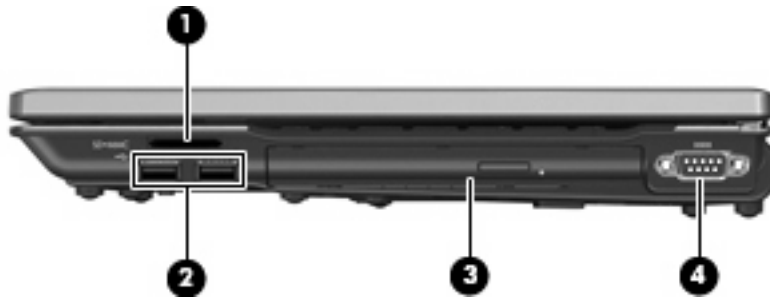

Item	Component	Function
(1)	Media Card Reader (select models only)	Supports the following optional digital card formats: <ul style="list-style-type: none"> • Memory Stick • Memory Stick Pro • MultiMediaCard • MultiMediaCard Plus • Secure Digital Memory Card • Secure Digital High Capacity Memory Card • xD-Picture Card • xD-Picture Card Type H • xD-Picture Card Type M
(2)	USB ports (2) (select models only)	Connect optional USB devices.
(3)	Optical drive	Reads an optical disc.
(4)	Serial port	Connects an optional device, such as a modem, mouse, or printer.

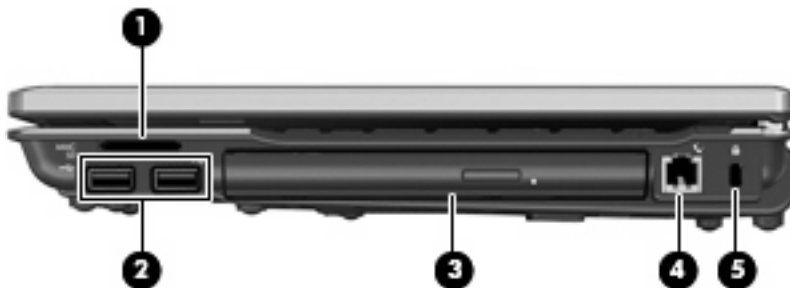

Item	Component	Function
(1)	Media Card Reader (select models only)	Supports the following optional digital card formats: <ul style="list-style-type: none"> • Memory Stick • Memory Stick Pro

Item	Component	Function
		<ul style="list-style-type: none"> • MultiMediaCard • MultiMediaCard Plus • Secure Digital Memory Card • Secure Digital High Capacity Memory Card • xD-Picture Card • xD-Picture Card Type H • xD-Picture Card Type M
(2)	USB ports (2) (select models only)	Connect optional USB devices.
(3)	Optical drive	Reads an optical disc.
(4)	RJ-11 (modem) jack	Connects a modem cable.
(5)	Security cable slot	Attaches an optional security cable to the computer.

NOTE: The security cable is designed to act as a deterrent, but it may not prevent the computer from being mishandled or stolen.

Left-side components

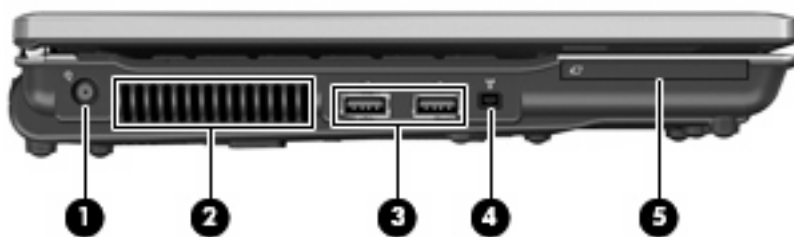

Item	Component	Function
(1)	Power connector	Connects an AC adapter.
(2)	Vent	Enables airflow to cool internal components.
		NOTE: The computer fan starts up automatically to cool internal components and prevent overheating. It is normal for the internal fan to cycle on and off during routine operation.
(3)	USB ports (2)	Connect optional USB devices.
(4)	1394 port (select models only)	Connects an optional IEEE 1394 or 1394a device, such as a camcorder.
(5)	ExpressCard slot	Supports optional ExpressCards.

Rear components

 **NOTE:** Refer to the illustration that most closely matches your computer.



Item	Component	Function
(1)	Security cable slot	Attaches an optional security cable to the computer. NOTE: The security cable is designed to act as a deterrent, but it may not prevent the computer from being mishandled or stolen.
(2)	RJ-11 (modem) jack	Connects a modem cable.
(3)	RJ-45 (network) jack	Connects a network cable.
(4)	External monitor port	Connects an external VGA monitor or projector.
(5)	S-Video-out jack	Connects an optional S-Video device such as a television, VCR, camcorder, overhead projector, or video capture card.



Item	Component	Function
(1)	RJ-45 (network) jack	Connects a network cable.
(2)	External monitor port	Connects an external VGA monitor or projector.
(3)	S-Video-out jack	Connects an optional S-Video device such as a television, VCR, camcorder, overhead projector, or video capture card.

Bottom components



Item	Component	Function
(1)	Battery bay	Holds the battery.
(2)	Battery release latch	Releases the battery from the battery bay.
(3)	SIM slot (select models only)	Contains a WWAN SIM. The SIM slot is located inside the battery bay.
(4)	Accessory battery connector	Connects an optional accessory battery.
(5)	Vents (4)	Enable airflow to cool internal components.
		NOTE: The computer fan starts up automatically to cool internal components and prevent overheating. It is normal for the internal fan to cycle on and off during routine operation.
(6)	Expansion memory module compartment	Contains the expansion memory module slot and the WLAN module.
		CAUTION: To prevent an unresponsive system, replace the wireless module only with a wireless module authorized for use in the computer by the governmental agency that regulates wireless devices in your country or region. If you replace the module and then receive a warning message, remove the module to restore computer functionality, and then contact technical support through Help and Support.
(7)	Bluetooth compartment (select models only)	Contains a Bluetooth device.
(8)	Hard drive bay	Holds the hard drive.
(9)	Docking connector (select models only)	Connects an optional docking device.

3 Illustrated parts catalog

Service tag

The service tag, affixed to the bottom of the computer, provides information that may be needed when troubleshooting system problems. The service tag provides the following information:

- (1) Product name: This is the product name affixed to the front of the computer.
- (2) Serial number (s/n): This is an alphanumeric identifier that is unique to each product.
- (3) Part number/Product number (p/n): This number provides specific information about the product's hardware components. The part number helps a service technician to determine what components and parts are needed.
- (4) Model description: This is the number used to locate documents, drivers, and support for the computer.
- (5) Warranty period: Describes the duration of the warranty period for this computer.

When ordering parts or requesting information, provide the computer serial number and model description provided on the service tag.

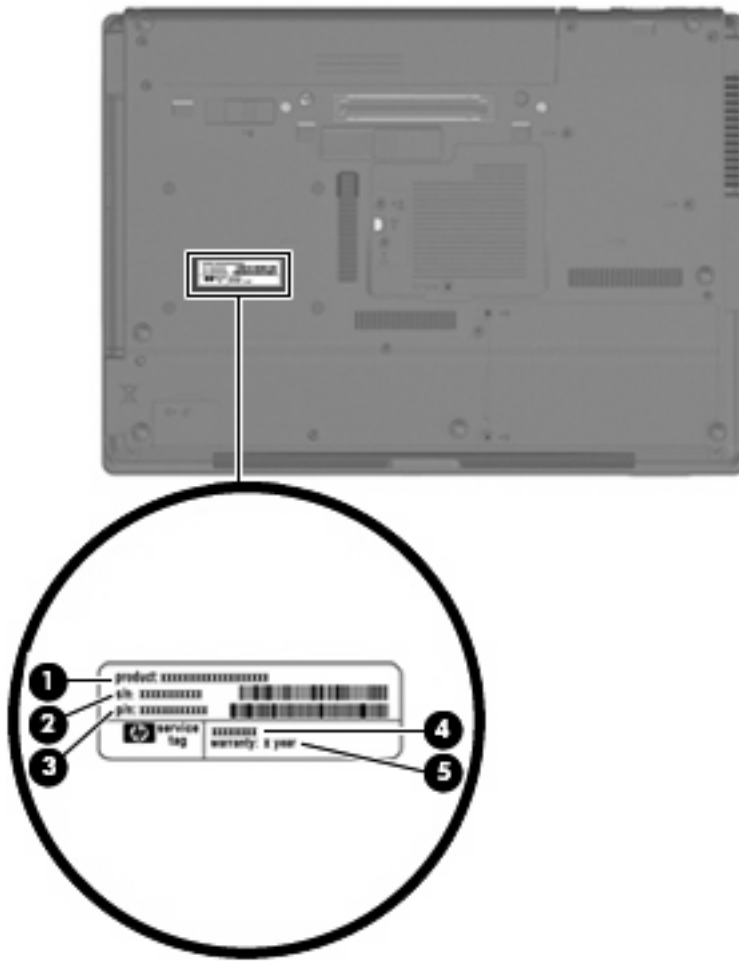

Computer major components

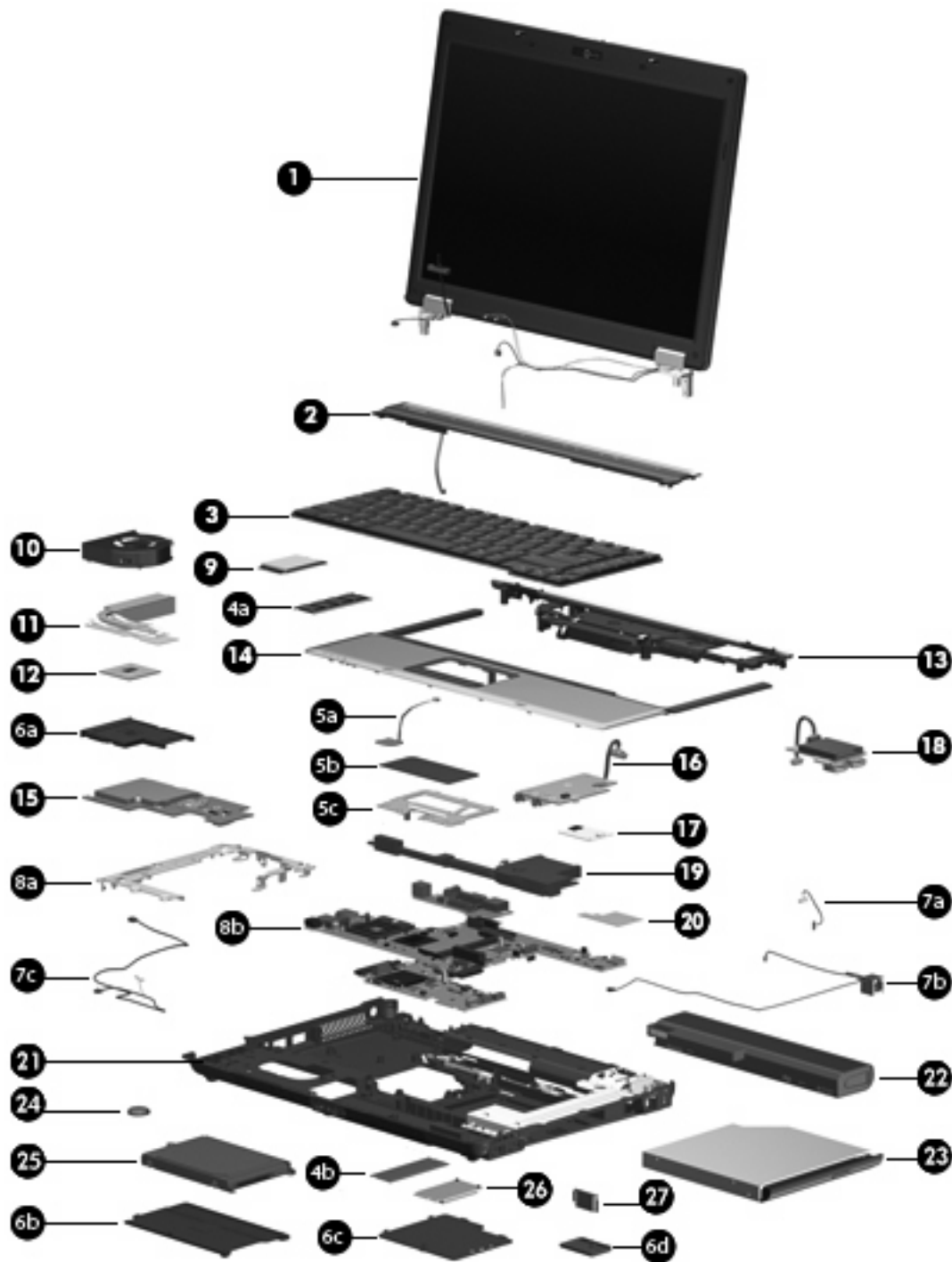

Item	Description	Spare part number
(1)	14.1-inch display assemblies (include 2 WLAN antenna transceivers and cables)	
For use only with HP Compaq 6535b computer models equipped with both WLAN and WWAN modules:		
	<ul style="list-style-type: none"> WXGA BrightView display assembly with 2 microphones and webcam 	492169-001

Item	Description	Spare part number
	• WXGA BrightView display assembly with 1 microphone	492170-001
	• WXGA+ display assembly with 2 microphones and webcam	492165-001
	• WXGA+ display assembly with 1 microphone	492166-001
	• WXGA display assembly with 2 microphones and webcam	492161-001
	• WXGA display assembly with 1 microphone	492162-001
	For use only with HP Compaq 6535b computer models equipped with a WLAN module and no WWAN module:	
	• WXGA BrightView display assembly with 2 microphones and webcam	492171-001
	• WXGA BrightView display assembly with 1 microphone	492172-001
	• WXGA+ display assembly with 2 microphones and webcam	492167-001
	• WXGA+ display assembly with 1 microphone	492168-001
	• 14.1-inch WXGA display assembly with 2 microphones and webcam	492163-001
	• 14.1-inch WXGA display assembly with 1 microphone	492164-001
	For use only with HP Compaq 6530b computer models equipped with both WLAN and WWAN modules:	
	• WXGA BrightView display assembly with 2 microphones and webcam	486273-001
	• WXGA BrightView display assembly with 1 microphone	486274-001
	• WXGA+ display assembly with 2 microphones and webcam	486269-001
	• WXGA+ display assembly with 1 microphone	486270-001
	• WXGA display assembly with 2 microphones and webcam	486265-001
	• WXGA display assembly with 2 microphones and webcam	486266-001
	For use only with HP Compaq 6530b computer models equipped with a WLAN module and no WWAN module:	
	• WXGA BrightView display assembly with 2 microphones and webcam	486275-001
	• WXGA BrightView display assembly with 1 microphone	486276-001
	• WXGA+ display assembly with 2 microphones and webcam	486271-001
	• WXGA+ display assembly with 1 microphone	486272-001
	• WXGA display assembly with 2 microphones and webcam	486267-001
	• WXGA display assembly with 1 microphone	486268-001
	Display internal components:	
	Display bezels	
	For use only with computer models equipped with a webcam	486770-001
	For use only with computer models not equipped with a webcam	487339-001
	Display hinge covers (includes left and right hinge covers)	486287-001
	Display hinges (includes left and right hinges)	486772-001
	Display inverters	
	For use only with HP Compaq 6535b computer models	495086-001

Item	Description	Spare part number
	For use only with HP Compaq 6530b computer models	486773-001
	Display panel cable	486776-001
	Wireless antenna sets (include 2 transceivers and cables)	
	WLAN antenna set	486777-001
	WWAN antenna set	486778-001
	Display Logo Kit	486290-001
	Display Rubber Kit (includes display bezel screw covers)	486775-001
	Display Screw Kit	486774-001
	Display enclosure	486286-001
(2)	Switch cover (includes power button board and cable and LED board and cable)	486282-001
(3)	Keyboards	
	For use in Belgium	486279-181
	For use in Brazil	486279-201
	For use in the Czech Republic	486279-221
	For use in Denmark	486279-081
	For use in France	486279-051
	For use in French Canada	486279-121
	For use in Germany	486279-041
	For use in Greece	486279-DJ1
	For use in Hungary	486279-211
	For use in Iceland	486279-DD1
	For use in Israel	486279-BB1
	For use in Italy	486279-061
	For use in Japan	486279-291
	For use in Latin America	486279-161
	For use in the Netherlands	486279-B31
	For use in Portugal	486279-131
	For use in Russia	486279-251
	For use in Saudi Arabia	486279-171
	For use in Slovakia	486279-231
	For use in Slovenia	486279-BA1
	For use in South Korea	486279-AD1
	For use in Spain	486279-071
	For use in Sweden	486279-B71

Item	Description	Spare part number
	For use in Switzerland	486279-BG1
	For use in Taiwan	486279-AB1
	For use in Thailand	486279-281
	For use in Turkey	486279-141
	For use in the United Kingdom	486279-031
	For use in the United States	486279-001
	Memory modules (PC2-6400, 667-MHz, DDR2)	
(4a)	Primary memory module (located under keyboard)	
(4b)	Expansion memory module (located under memory/WLAN module compartment cover)	
	2048-MB	483194-001
	1024-MB	483193-001
	TouchPad assemblies (include the components listed below):	
(5a)	Fingerprint reader board and cable (included only in spare part kit 486277-001)	
(5b)	TouchPad board and cable	
(5c)	TouchPad board bracket	
	For use only with computer models equipped with a fingerprint reader (includes a fingerprint reader board and cable)	486277-001
	For use only with computer models not equipped with a fingerprint reader	486278-001
	Plastics Kit (see Plastics Kit on page 28 for more Plastics Kit spare part information):	486292-001
(6a)	PC Card slot bezel	
(6b)	Memory/WLAN module compartment cover	
(6c)	Hard drive bay cover	
(6d)	Bluetooth module compartment cover	
	Cable Kit (see Cable Kit on page 29 for more Cable Kit spare part information):	486281-001
(7a)	Bluetooth module cable	
(7b)	Modem module cable (includes RJ-11 connector)	
(7c)	Microphone extension cable	
	System boards (include system board bracket, system board, and replacement thermal material):	
(8a)	System board bracket	
(8b)	System board	
	For use only with HP Compaq 6535b computer models equipped with both WLAN and WWAN modules	488193-001
	For use only with HP Compaq 6535b computer models equipped with a WLAN module and no WWAN module	488194-001

Item	Description	Spare part number
	For use only with HP Compaq 6530b computer models equipped with both WLAN and WWAN modules	486247-001
	For use only with HP Compaq 6530b computer models equipped with a WLAN module and no WWAN module	486248-001
(9)	HSDPA EVDO WWAN module	483377-001
(10)	Fan	486288-001
(11)	Heat sinks (include heat sink clip and replacement thermal material)	
	For use only with HP Compaq 6535b computer models	488315-001
	For use only with HP Compaq 6530b computer models	486289-001
(12)	Processors (include replacement thermal material)	
	AMD processors for use only with HP Compaq 6535b computer models:	
	• Turion 64 ZM-86 2.40-GHz processor	488198-001
	• Turion 64 ZM-82 2.20-GHz processor	488196-001
	• Turion 64 ZM-80 2.10-GHz processor	488195-001
	• Turion 64 RM-70 2.00-GHz processor	488199-001
	• Sempron SI-40 2.00-GHz processor	488197-001
	• Athlon QL-60 1.90-GHz processor	488200-001
	Intel Core 2 Duo processors for use only with HP Compaq 6530b computer models:	
	• T9600 2.80-GHz (6-MB L2 cache, 800-MHz FSB)	486257-001
	• T9400 2.53-GHz (6-MB L2 cache, 800-MHz FSB)	486256-001
	• T8600 2.40-GHz (3-MB L2 cache, 800-MHz FSB)	486255-001
	• T8400 2.26-GHz (3-MB L2 cache, 800-MHz FSB)	486254-001
(13)	Rear cover	486291-001
(14)	Top cover	486283-001
(15)	ExpressCard board (includes RTC battery)	486251-001
(16)	Audio board (includes cable)	486250-001
(17)	Modem modules	
	NOTE: The modem module spare part kits do not include a modem module cable. The modem module cable is included in the Cable Kit, spare part number 486281-001.	
	For use in all countries and regions except Australia and New Zealand	491575-001
	For use only in Australia and New Zealand	491575-011
(18)	USB/digital media board (includes cable)	486249-001
(19)	Speaker	486280-001
(20)	SIM connector board	486252-001
(21)	Base enclosures (include rubber feet)	

Item	Description	Spare part number
	For use only with computer models equipped with a WWAN module (includes SIM slot opening)	486284-001
	For use only with computer models not equipped with a WWAN module (does not include SIM slot opening)	486285-001
	Rubber Kit (not illustrated, contains 7 computer feet)	486293-001
(22)	Batteries	
	6-cell, 55-Wh Li-ion battery	486296-001
	6-cell, 47-Wh Li-ion battery	486295-001
(23)	Optical drives (include bezel and bracket)	
	DVD±RW and CD-RW SuperMulti Double-Layer Combo Drive	486262-001
	DVD/CD-RW Combo Drive	486263-001
	DVD-ROM Drive	486264-001
(24)	RTC battery	449137-001
(25)	Hard drives (include hard drive bracket)	
	250-GB, 5400-rpm	486261-001
	160-GB, 5400-rpm	486260-001
	120-GB, 7200-rpm	486259-001
	120-GB, 5400-rpm	486782-001
(26)	WLAN modules	
	Broadcom 4322 802.11a/b/g/n WLAN modules:	
	<ul style="list-style-type: none"> For use in Antigua and Barbuda, Barbados, Belize, Canada, the Cayman Islands, Guam, Puerto Rico, Trinidad and Tobago, the U.S. Virgin Islands, and the United States 	487330-001
	<ul style="list-style-type: none"> For use in Afghanistan, Albania, Algeria, Andorra, Angola, Antigua and Barbuda, Argentina, Armenia, Aruba, Australia, Austria, Azerbaijan, the Bahamas, Bahrain, Bangladesh, Barbados, Belarus, Belgium, Belize, Benin, Bermuda, Bhutan, Bolivia, Bosnia and Herzegovina, Botswana, Brazil, the British Virgin Islands, Brunei, Bulgaria, Burkina Faso, Burundi, Cameroon, Cape Verde, the Central African Republic, Chad, Chile, the People's Republic of China, Colombia, Comoros, the Congo, Costa Rica, Croatia, Cyprus, the Czech Republic, Denmark, Djibouti, Dominica, the Dominican Republic, East Timor, Ecuador, Egypt, El Salvador, Equatorial Guinea, Eritrea, Estonia, Ethiopia, Fiji, Finland, France, French Guiana, Gabon, Gambia, Georgia, Germany, Ghana, Gibraltar, Greece, Grenada, Guadeloupe, Guatemala, Guinea, Guinea-Bissau, Guyana, Haiti, Honduras, Hong Kong, Hungary, Iceland, India, Ireland, Israel, Italy, the Ivory Coast, Jamaica, Jordan, Kazakhstan, Kenya, Kiribati, Kyrgyzstan, Laos, Latvia, Lebanon, Lesotho, Liberia, Liechtenstein, Lithuania, Luxembourg, Macedonia, Madagascar, Malawi, Malaysia, the Maldives, Mali, Malta, the Marshall Islands, Martinique, Mauritania, Mauritius, Mexico, Micronesia, Monaco, Mongolia, Montenegro, Morocco, Mozambique, Namibia, Nauru, Nepal, the Nether Antilles, the Netherlands, New Zealand, Nicaragua, Niger, Nigeria, Norway, Oman, Pakistan, Palau, Panama, Papua New Guinea, Paraguay, Peru, the Philippines, Poland, Portugal, the Republic of Moldova, Romania, Russia, Rwanda, Samoa, San Marino, Sao Tome and Principe, Saudi Arabia, Senegal, Serbia, the Seychelles, Sierra Leone, Singapore, Slovakia, Slovenia, the Solomon Islands, Somalia, South Africa, South Korea, Spain, Sri Lanka, St. Kitts and Nevis, St. Lucia, St. Vincent and the Grenadines, Suriname, Swaziland, Sweden, Switzerland, Taiwan, Tajikistan, Tanzania, Togo, Tonga, Trinidad and Tobago, Tunisia, Turkey, Turkmenistan, 	487330-002

Item	Description	Spare part number
	Tuvalu, Uganda, Ukraine, the United Arab Emirates, the United Kingdom, Uruguay, Uzbekistan, Vanuatu, Venezuela, Vietnam, Yemen, Zaire, Zambia, and Zimbabwe	
	Broadcom BCM4312 802.11b/g WLAN modules:	
	<ul style="list-style-type: none"> For use in Canada, the Cayman Islands, Puerto Rico, the U.S. Virgin Islands, Guam, and the United States 	490811-001
	<ul style="list-style-type: none"> For use in Afghanistan, Albania, Algeria, Andorra, Angola, Antigua and Barbuda, Argentina, Armenia, Aruba, Australia, Austria, Azerbaijan, the Bahamas, Bahrain, Bangladesh, Barbados, Belarus, Belgium, Belize, Benin, Bermuda, Bhutan, Bolivia, Bosnia and Herzegovina, Botswana, Brazil, the British Virgin Islands, Brunei, Bulgaria, Burkina Faso, Burundi, Cameroon, Cape Verde, the Central African Republic, Chad, Chile, the People's Republic of China, Colombia, Comoros, the Congo, Costa Rica, Croatia, Cyprus, the Czech Republic, Denmark, Djibouti, Dominica, the Dominican Republic, East Timor, Ecuador, Egypt, El Salvador, Equatorial Guinea, Eritrea, Estonia, Ethiopia, Fiji, Finland, France, French Guiana, Gabon, Gambia, Georgia, Germany, Ghana, Gibraltar, Greece, Grenada, Guadeloupe, Guatemala, Guinea, Guinea-Bissau, Guyana, Haiti, Honduras, Hong Kong, Hungary, Iceland, India, Ireland, Israel, Italy, the Ivory Coast, Jamaica, Jordan, Kazakhstan, Kenya, Kiribati, Kyrgyzstan, Laos, Latvia, Lebanon, Lesotho, Liberia, Liechtenstein, Lithuania, Luxembourg, Macedonia, Madagascar, Malawi, Malaysia, the Maldives, Mali, Malta, the Marshall Islands, Martinique, Mauritania, Mauritius, Mexico, Micronesia, Monaco, Mongolia, Montenegro, Morocco, Mozambique, Namibia, Nauru, Nepal, the Nether Antilles, the Netherlands, New Zealand, Nicaragua, Niger, Nigeria, Norway, Oman, Pakistan, Palau, Panama, Papua New Guinea, Paraguay, Peru, the Philippines, Poland, Portugal, the Republic of Moldova, Romania, Russia, Rwanda, Samoa, San Marino, Sao Tome and Principe, Saudi Arabia, Senegal, Serbia, the Seychelles, Sierra Leone, Singapore, Slovakia, Slovenia, the Solomon Islands, Somalia, South Africa, South Korea, Spain, Sri Lanka, St. Kitts and Nevis, St. Lucia, St. Vincent and the Grenadines, Suriname, Swaziland, Sweden, Switzerland, Taiwan, Tajikistan, Tanzania, Togo, Tonga, Trinidad and Tobago, Tunisia, Turkey, Turkmenistan, Tuvalu, Uganda, Ukraine, the United Arab Emirates, the United Kingdom, Uruguay, Uzbekistan, Vanuatu, Venezuela, Vietnam, Yemen, Zaire, Zambia, and Zimbabwe 	490811-002
(27)	Bluetooth modules (do not include Bluetooth module cable)	
	NOTE: The Bluetooth module spare part kits do not include a Bluetooth module cable. The Bluetooth module cable is included in the Cable Kit, spare part number 486281-001.	
	For use only with HP Compaq 6535b computer models in all countries and regions except Japan and Asia-Pacific countries and regions	398393-002
	For use only with HP Compaq 6535b computer models in Japan and Asia-Pacific countries and regions	450066-001
	For use only with HP Compaq 6530b computer models	490809-001

Plastics Kit

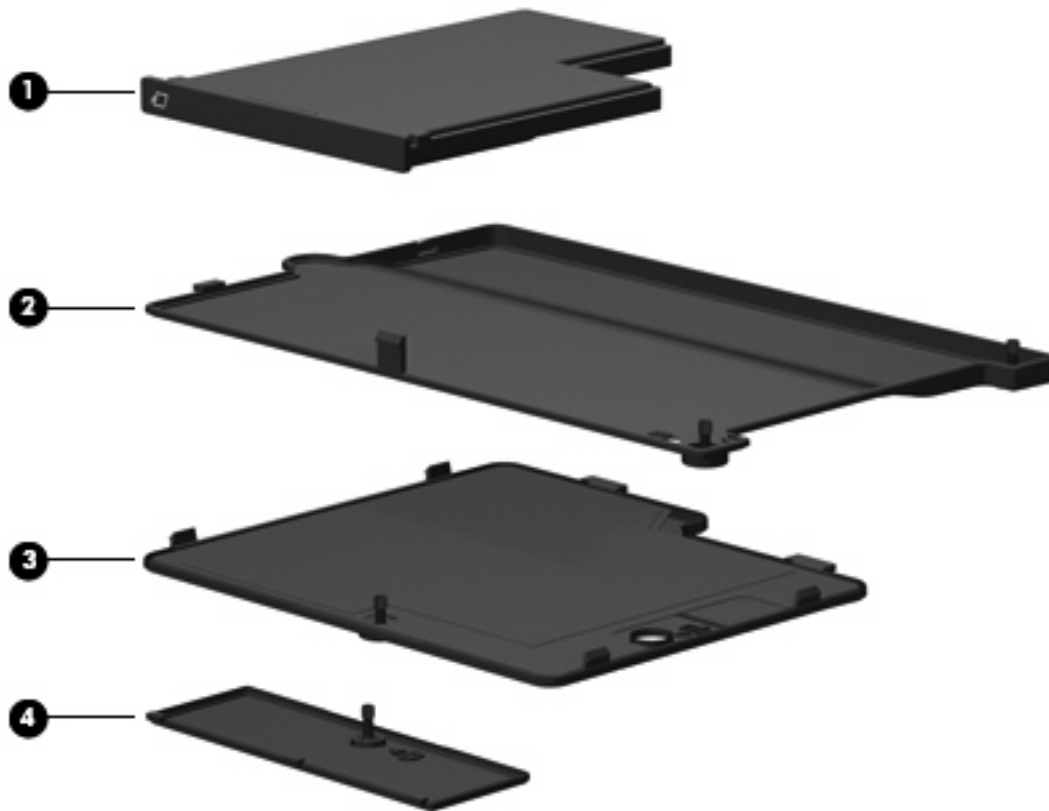

Item	Description	Spare part number
	Plastics Kit:	486292-001
(1)	PC Card slot bezel	
(2)	Hard drive bay cover (includes 2 captive screws, secured by C-clips)	
(3)	Memory/WLAN module compartment cover (includes one captive screw, secured by a C-clip)	
(4)	Bluetooth module compartment cover (includes one captive screw, secured by a C-clip)	

Cable Kit

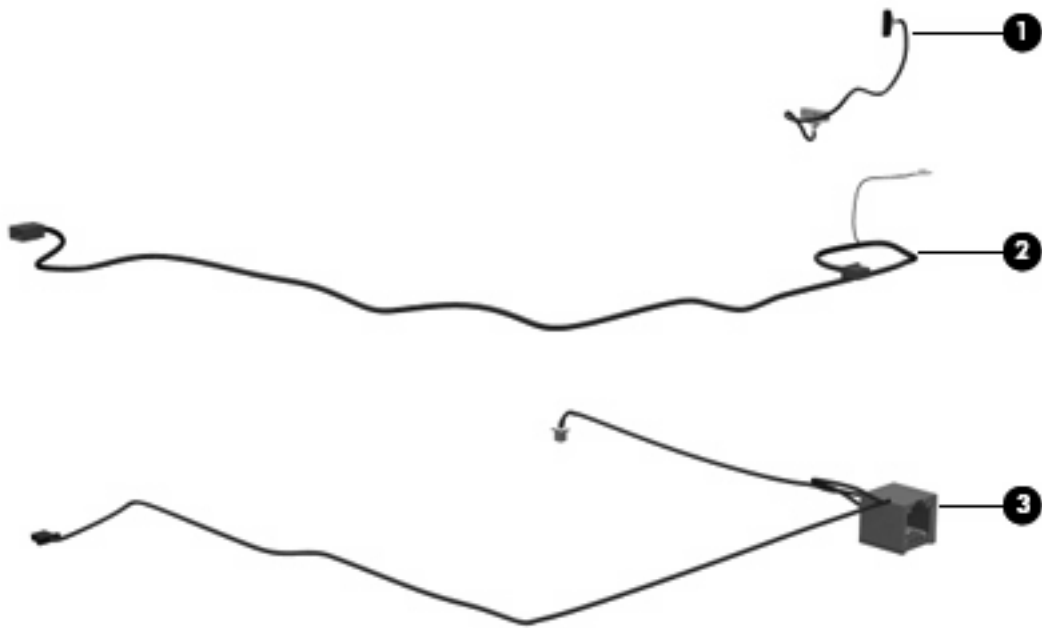

Item	Description	Spare part number
	Cable Kit:	486281-001
(1)	Bluetooth module cable	
(2)	Microphone extension cable	
(3)	Modem module cable (includes RJ-11 connector)	

Mass storage devices



Item	Description	Spare part number
(1)	Hard drives (include hard drive bracket)	
	250-GB, 5400-rpm	486261-001
	160-GB, 5400-rpm	486260-001
	120-GB, 7200-rpm	486259-001
	120-GB, 5400-rpm	486782-001
(2)	Optical drives (include bezel and bracket)	
	DVD±RW and CD-RW SuperMulti Double-Layer Combo Drive	486262-001
	DVD/CD-RW Combo Drive	486263-001
	DVD-ROM Drive	486264-001

Miscellaneous parts

Description	Spare part number
AC adapters	
90-W PFC HP Smart AC Adapter for use in all countries and regions except India	463955-001
90-W non-PFC HP Smart AC Adapter for use only in India	463956-001
Power cords:	
For use in Australia	246959-011
For use in Brazil	246959-201
For use in Denmark	246959-081
For use in Europe, the Middle East, and Africa	246959-021
For use in Israel	246959-BB1
For use in Italy	246959-061
For use in Japan	246959-291
For use in South Korea	246959-AD1
For use in Switzerland	246959-AG1
For use in the United Kingdom	246959-031
For use in the United States	246959-001
Screw Kit	486294-001
<ul style="list-style-type: none"> • Hex HM5.0×9.0 screw lock • Phillips PM3.0×4.0 screw • Phillips PM2.5×10.0 captive screw • Phillips PM2.5×9.0 captive screw • Phillips PM2.5×7.0 captive screw • Phillips PM2.5×7.0 screw • Phillips PM2.5×5.0 screw • Phillips PM2.5×4.0 screw • Phillips PM2.5×3.0 screw • Phillips PM2.5×3.0 broad-head screw • Phillips PM2.0×5.0 screw • Phillips PM2.0×5.0 captive screw • Phillips PM2.0×4.0 captive screw • Phillips PM2.0×3.0 screw • Torx T8M2.5×9.0 screw • Torx T8M2.5×6.0 screw 	

Sequential part number listing

Spare part number	Description
246959-001	Power cord for use in the United States
246959-011	Power cord for use in Australia
246959-021	Power cord for use in Europe, the Middle East, and Africa
246959-031	Power cord for use in the United Kingdom
246959-061	Power cord for use in Italy
246959-081	Power cord for use in Denmark
246959-201	Power cord for use in Brazil
246959-291	Power cord for use in Japan
246959-AD1	Power cord for use in South Korea
246959-AG1	Power cord for use in Switzerland
246959-BB1	Power cord for use in Israel
398393-002	Bluetooth module for use only on HP Compaq 6535b computer models in all countries and regions except in Japan and Asia-Pacific countries and regions NOTE: The Bluetooth module spare part kits do not include a Bluetooth module cable. The Bluetooth module cable is included in the Cable Kit, spare part number 486281-001.
449137-001	RTC battery
450066-001	Bluetooth module for use only on HP Compaq 6535b computer models in Japan and Asia-Pacific countries and regions NOTE: The Bluetooth module spare part kits do not include a Bluetooth module cable. The Bluetooth module cable is included in the Cable Kit, spare part number 486281-001.
463955-001	90-W PFC HP Smart AC Adapter for use in all countries and regions except India
463956-001	90-W non-PFC HP Smart AC Adapter for use only in India
483193-001	1024-MB memory module (PC2-6400, 667-MHz, DDR2)
483194-001	2048-MB memory module (PC2-6400, 667-MHz, DDR2)
483377-001	HSDPA EVDO WWAN module
486247-001	System board for use only with HP Compaq 6530b computer models equipped with both WLAN and WWAN modules (includes replacement thermal material)
486248-001	System board for use only with HP Compaq 6530b computer models equipped with a WLAN module and no WWAN module (includes replacement thermal material)
486249-001	USB/digital media board (includes cable)
486250-001	Audio board (includes cable)
486251-001	ExpressCard board (includes RTC battery)
486252-001	SIM connector board
486254-001	Intel Core2 Duo T8400 2.26-GHz processor for use only with HP Compaq 6530b computer models (3-MB L2 cache, 800-MHz FSB; includes replacement thermal material)

Spare part number	Description
486255-001	Intel Core2 Duo T8600 2.40-GHz processor for use only with HP Compaq 6530b computer models (3-MB L2 cache, 800-MHz FSB; includes replacement thermal material)
486256-001	Intel Core2 Duo T9400 2.53-GHz processor for use only with HP Compaq 6530b computer models (6-MB L2 cache, 800-MHz FSB; includes replacement thermal material)
486257-001	Intel Core2 Duo T9600 2.80-GHz processor for use only with HP Compaq 6530b computer models (6-MB L2 cache, 800-MHz FSB; includes replacement thermal material)
486259-001	120-GB, 7200-rpm hard drive (includes hard drive bracket)
486260-001	160-GB, 5400-rpm hard drive (includes hard drive bracket)
486261-001	250-GB, 5400-rpm hard drive (includes hard drive bracket)
486262-001	DVD±RW and CD-RW SuperMulti Double-Layer Combo Drive (includes bezel and bracket)
486263-001	DVD/CD-RW Combo Drive (includes bezel and bracket)
486264-001	DVD-ROM Drive (includes bezel and bracket)
486265-001	14.1-inch WXGA+ display assembly with 2 microphones and webcam for use only with HP Compaq 6530b computer models equipped with both WLAN and WWAN modules
486266-001	14.1-inch WXGA display assembly with 2 microphones and webcam for use only with HP Compaq 6530b computer models equipped with both WLAN and WWAN modules
486267-001	14.1-inch WXGA display assembly with 2 microphones and webcam for use only with HP Compaq 6530b computer models equipped with a WLAN module and no WWAN module
486268-001	14.1-inch WXGA display assembly with 1 microphone for use only with HP Compaq 6530b computer models equipped with a WLAN module and no WWAN module
486269-001	14.1-inch WXGA+ display assembly with 2 microphones and webcam for use only with HP Compaq 6530b computer models equipped with both WLAN and WWAN modules
486270-001	14.1-inch WXGA+ display assembly with 1 microphone for use only with HP Compaq 6530b computer models equipped with both WLAN and WWAN modules
486271-001	14.1-inch WXGA+ display assembly with 2 microphones and webcam for use only with HP Compaq 6530b computer models equipped with a WLAN module and no WWAN module
486272-001	14.1-inch WXGA+ display assembly with 1 microphone for use only with HP Compaq 6530b computer models equipped with a WLAN module and no WWAN module
486273-001	14.1-inch WXGA BrightView display assembly with 2 microphones and webcam for use only with HP Compaq 6530b computer models equipped with both WLAN and WWAN modules
486274-001	14.1-inch WXGA BrightView display assembly with 1 microphone for use only with HP Compaq 6530b computer models equipped with both WLAN and WWAN modules
486275-001	14.1-inch WXGA BrightView display assembly with 2 microphones and webcam for use only with HP Compaq 6530b computer models equipped with a WLAN module and no WWAN module
486276-001	14.1-inch WXGA BrightView display assembly with 1 microphone for use only with HP Compaq 6530b computer models equipped with a WLAN module and no WWAN module
486277-001	TouchPad assembly for use only with computer models equipped with a fingerprint reader (includes a TouchPad bracket and a fingerprint reader board and cable)
486278-001	TouchPad assembly for use only with computer models not equipped with a fingerprint reader (includes a TouchPad bracket)
486279-001	Keyboard for use in the United States

Spare part number	Description
486279-031	Keyboard for use in the United Kingdom
486279-041	Keyboard for use in Germany
486279-051	Keyboard for use in France
486279-061	Keyboard for use in Italy
486279-071	Keyboard for use in Spain
486279-081	Keyboard for use in Denmark
486279-091	Keyboard for use in Norway
486279-121	Keyboard for use in French Canada
486279-131	Keyboard for use in Portugal
486279-141	Keyboard for use in Turkey
486279-161	Keyboard for use in Latin America
486279-171	Keyboard for use in Saudi Arabia
486279-181	Keyboard for use in Belgium
486279-201	Keyboard for use in Brazil
486279-211	Keyboard for use in Hungary
486279-221	Keyboard for use in the Czech Republic
486279-231	Keyboard for use in Slovakia
486279-251	Keyboard for use in Russia
486279-281	Keyboard for use in Thailand
486279-291	Keyboard for use in Japan
486279-AB1	Keyboard for use in Taiwan
486279-AD1	Keyboard for use in South Korea
486279-B31	Keyboard for use in the Netherlands
486279-B71	Keyboard for use in Sweden
486279-BA1	Keyboard for use in Slovenia
486279-BB1	Keyboard for use in Israel
486279-BG1	Keyboard for use in Switzerland
486279-DD1	Keyboard for use in Iceland
486279-DJ1	Keyboard for use in Greece
486280-001	Speaker
486281-001	Cable Kit (see Cable Kit on page 29 for more Cable Kit spare part information)
486282-001	Switch cover (includes power button board and cable and LED board and cable)
486283-001	Top cover

Spare part number	Description
486284-001	Base enclosure for use only with computer models equipped with a WWAN module (includes SIM slot opening)
486285-001	Base enclosure for use only with computer models not equipped with a WWAN module (does not include SIM slot opening)
486286-001	Display enclosure
486287-001	Display hinge covers (includes left and right hinge covers)
486288-001	Fan
486289-001	Heat sink for use only with HP Compaq 6530b computer models (includes replacement thermal material)
486290-001	Display Logo Kit
486291-001	Rear cover
486292-001	Plastics Kit (see Plastics Kit on page 28 for more Plastics Kit spare part information)
486293-001	Rubber Kit (not illustrated, contains 7 computer feet)
486294-001	Screw Kit
486295-001	6-cell, 47-Wh Li-ion battery
486296-001	6-cell, 55-Wh Li-ion battery
486770-001	Display bezel for use only with computer models equipped with a webcam
486772-001	Display hinges (includes left and right hinges)
486773-001	Display inverter for use only with HP Compaq 6530b computer models
486774-001	Display Screw Kit
486775-001	Display Rubber Kit (includes display bezel screw covers)
486776-001	Display panel cable
486777-001	WLAN wireless antenna set (includes 2 transceivers and cables)
486778-001	WWAN wireless antenna set (includes 2 transceivers and cables)
486782-001	120-GB, 7200-rpm hard drive (includes hard drive bracket)
487330-001	Broadcom 4322 802.11a/b/g/n WLAN module for use in Antigua and Barbuda, Barbados, Belize, Canada, the Cayman Islands, Guam, Puerto Rico, Trinidad and Tobago, the U.S. Virgin Islands, and the United States
487330-002	Broadcom 4322 802.11a/b/g/n WLAN module for use in Afghanistan, Albania, Algeria, Andorra, Angola, Antigua and Barbuda, Argentina, Armenia, Aruba, Australia, Austria, Azerbaijan, the Bahamas, Bahrain, Bangladesh, Barbados, Belarus, Belgium, Belize, Benin, Bermuda, Bhutan, Bolivia, Bosnia and Herzegovina, Botswana, Brazil, the British Virgin Islands, Brunei, Bulgaria, Burkina Faso, Burundi, Cameroon, Cape Verde, the Central African Republic, Chad, Chile, the People's Republic of China, Colombia, Comoros, the Congo, Costa Rica, Croatia, Cyprus, the Czech Republic, Denmark, Djibouti, Dominica, the Dominican Republic, East Timor, Ecuador, Egypt, El Salvador, Equatorial Guinea, Eritrea, Estonia, Ethiopia, Fiji, Finland, France, French Guiana, Gabon, Gambia, Georgia, Germany, Ghana, Gibraltar, Greece, Grenada, Guadeloupe, Guatemala, Guinea, Guinea-Bissau, Guyana, Haiti, Honduras, Hong Kong, Hungary, Iceland, India, Ireland, Israel, Italy, the Ivory Coast, Jamaica, Jordan, Kazakhstan, Kenya, Kiribati, Kyrgyzstan, Laos, Latvia, Lebanon, Lesotho, Liberia, Liechtenstein, Lithuania, Luxembourg, Macedonia, Madagascar, Malawi, Malaysia, the Maldives, Mali, Malta, the Marshall Islands, Martinique, Mauritania, Mauritius, Mexico, Micronesia, Monaco, Mongolia, Montenegro, Morocco, Mozambique, Namibia, Nauru, Nepal, the Nether Antilles, the Netherlands, New Zealand, Nicaragua, Niger, Nigeria, Norway, Oman, Pakistan, Palau, Panama, Papua New Guinea, Paraguay, Peru, the Philippines, Poland, Portugal,

Spare part number	Description
	the Republic of Moldova, Romania, Russia, Rwanda, Samoa, San Marino, Sao Tome and Principe, Saudi Arabia, Senegal, Serbia, the Seychelles, Sierra Leone, Singapore, Slovakia, Slovenia, the Solomon Islands, Somalia, South Africa, South Korea, Spain, Sri Lanka, St. Kitts and Nevis, St. Lucia, St. Vincent and the Grenadines, Suriname, Swaziland, Sweden, Switzerland, Taiwan, Tajikistan, Tanzania, Togo, Tonga, Trinidad and Tobago, Tunisia, Turkey, Turkmenistan, Tuvalu, Uganda, Ukraine, the United Arab Emirates, the United Kingdom, Uruguay, Uzbekistan, Vanuatu, Venezuela, Vietnam, Yemen, Zaire, Zambia, and Zimbabwe
487339-001	Display bezel for use only with computer models not equipped with a webcam
488193-001	System board for use only with HP Compaq 6535b computer models equipped with both WLAN and WWAN modules (includes replacement thermal material)
488194-001	System board for use only with HP Compaq 6535b computer models equipped with a WLAN module and no WWAN module
488195-001	AMD Turion 64 ZM-80 2.10-GHz processor for use only with HP Compaq 6535b computer models (includes replacement thermal material)
488196-001	AMD Turion 64 ZM-82 2.20-GHz processor for use only with HP Compaq 6535b computer models (includes replacement thermal material)
488197-001	AMD Sempron SI-40 2.00-GHz processor for use only with HP Compaq 6535b computer models (includes replacement thermal material)
488198-001	AMD Turion 64 ZM-86 2.40-GHz processor for use only with HP Compaq 6535b computer models (includes replacement thermal material)
488199-001	AMD Turion 64 RM-70 2.00-GHz processor for use only with HP Compaq 6535b computer models (includes replacement thermal material)
488200-001	AMD Athlon QL-60 1.90-GHz processor for use only with HP Compaq 6535b computer models (includes replacement thermal material)
488315-001	Heat sink for use only with HP Compaq 6535b computer models (includes replacement thermal material)
490809-001	Bluetooth module for use only with HP Compaq 6530b computer models NOTE: The Bluetooth module spare part kits do not include a Bluetooth module cable. The Bluetooth module cable is included in the Cable Kit, spare part number 486281-001.
490811-001	Broadcom BCM4312 802.11b/g WLAN module for use in Canada, the Cayman Islands, Puerto Rico, the U.S. Virgin Islands, Guam, and the United States
490811-002	Broadcom BCM4312 802.11b/g WLAN module for use in Afghanistan, Albania, Algeria, Andorra, Angola, Antigua and Barbuda, Argentina, Armenia, Aruba, Australia, Austria, Azerbaijan, the Bahamas, Bahrain, Bangladesh, Barbados, Belarus, Belgium, Belize, Benin, Bermuda, Bhutan, Bolivia, Bosnia and Herzegovina, Botswana, Brazil, the British Virgin Islands, Brunei, Bulgaria, Burkina Faso, Burundi, Cameroon, Cape Verde, the Central African Republic, Chad, Chile, the People's Republic of China, Colombia, Comoros, the Congo, Costa Rica, Croatia, Cyprus, the Czech Republic, Denmark, Djibouti, Dominica, the Dominican Republic, East Timor, Ecuador, Egypt, El Salvador, Equatorial Guinea, Eritrea, Estonia, Ethiopia, Fiji, Finland, France, French Guiana, Gabon, Gambia, Georgia, Germany, Ghana, Gibraltar, Greece, Grenada, Guadeloupe, Guatemala, Guinea, Guinea-Bissau, Guyana, Haiti, Honduras, Hong Kong, Hungary, Iceland, India, Ireland, Israel, Italy, the Ivory Coast, Jamaica, Jordan, Kazakhstan, Kenya, Kiribati, Kyrgyzstan, Laos, Latvia, Lebanon, Lesotho, Liberia, Liechtenstein, Lithuania, Luxembourg, Macedonia, Madagascar, Malawi, Malaysia, the Maldives, Mali, Malta, the Marshall Islands, Martinique, Mauritania, Mauritius, Mexico, Micronesia, Monaco, Mongolia, Montenegro, Morocco, Mozambique, Namibia, Nauru, Nepal, the Nether Antilles, the Netherlands, New Zealand, Nicaragua, Niger, Nigeria, Norway, Oman, Pakistan, Palau, Panama, Papua New Guinea, Paraguay, Peru, the Philippines, Poland, Portugal, the Republic of Moldova, Romania, Russia, Rwanda, Samoa, San Marino, Sao Tome and Principe, Saudi Arabia, Senegal, Serbia, the Seychelles, Sierra Leone, Singapore, Slovakia, Slovenia, the Solomon Islands, Somalia, South Africa, South Korea, Spain, Sri Lanka, St. Kitts and Nevis, St. Lucia, St. Vincent and the Grenadines, Suriname, Swaziland, Sweden, Switzerland, Taiwan, Tajikistan, Tanzania, Togo, Tonga, Trinidad and Tobago, Tunisia, Turkey, Turkmenistan, Tuvalu, Uganda, Ukraine,

Spare part number	Description
	the United Arab Emirates, the United Kingdom, Uruguay, Uzbekistan, Vanuatu, Venezuela, Vietnam, Yemen, Zaire, Zambia, and Zimbabwe
491575-001	Modem module for use in all countries and regions except Australia and New Zealand NOTE: The modem module spare part kits do not include a modem module cable. The modem module cable is included in the Cable Kit, spare part number 486281-001.
491575-011	Modem module for use only in Australia and New Zealand NOTE: The modem module spare part kits do not include a modem module cable. The modem module cable is included in the Cable Kit, spare part number 486281-001.
492161-001	14.1-inch WXGA display assembly with 2 microphones and webcam for use only with HP Compaq 6535b computer models equipped with both WLAN and WWAN modules
492162-001	14.1-inch WXGA display assembly with 1 microphone for use only with HP Compaq 6535b computer models equipped with WLAN and WWAN modules
492163-001	14.1-inch WXGA display assembly with 2 microphones and webcam for use only with HP Compaq 6535b computer models equipped with WLAN modules
492164-001	14.1-inch WXGA display assembly with 1 microphone for use only with HP Compaq 6535b computer models equipped with a WLAN module and no WWAN module
492165-001	14.1-inch WXGA+ display assembly with 2 microphones and webcam for use only with HP Compaq 6535b computer models equipped with both WLAN and WWAN modules
492166-001	14.1-inch WXGA+ display assembly with 1 microphone for use only with HP Compaq 6535b computer models equipped with WLAN and WWAN modules
492167-001	14.1-inch WXGA+ display assembly with 2 microphones and webcam for use only with HP Compaq 6535b computer models equipped with WLAN modules
492168-001	14.1-inch WXGA+ display assembly with 1 microphone for use only with HP Compaq 6535b computer models equipped with a WLAN module and no WWAN module
492169-001	14.1-inch WXGA BrightView display assembly with 2 microphones and webcam for use only with HP Compaq 6535b computer models equipped with both WLAN and WWAN modules
492170-001	14.1-inch WXGA BrightView display assembly with 1 microphone for use only with HP Compaq 6535b computer models equipped with both WLAN and WWAN modules
492171-001	14.1-inch WXGA BrightView display assembly with 2 microphones and webcam for use only with HP Compaq 6535b computer models equipped with a WLAN module and no WWAN module
492172-001	14.1-inch WXGA BrightView display assembly with 1 microphone for use only with HP Compaq 6535b computer models equipped with a WLAN module and no WWAN module
495086-001	Display inverter for use only with HP Compaq 6535b computer models

4 Removal and replacement procedures

Preliminary replacement requirements

Tools required

You will need the following tools to complete the removal and replacement procedures:

- Flat-bladed screwdriver
- Magnetic screwdriver
- Phillips P0 and P1 screwdrivers
- Torx T8 screwdriver
- 5.0-mm (3/16-inch) nut driver

Service considerations

The following sections include some of the considerations that you must keep in mind during disassembly and assembly procedures.

 **NOTE:** As you remove each subassembly from the computer, place the subassembly (and all accompanying screws) away from the work area to prevent damage.

Plastic parts

Using excessive force during disassembly and reassembly can damage plastic parts. Use care when handling the plastic parts. Apply pressure only at the points designated in the maintenance instructions.

Cables and connectors

-
- △ **CAUTION:** When servicing the computer, be sure that cables are placed in their proper locations during the reassembly process. Improper cable placement can damage the computer.
-

Cables must be handled with extreme care to avoid damage. Apply only the tension required to unseat or seat the cables during removal and insertion. Handle cables by the connector whenever possible. In all cases, avoid bending, twisting, or tearing cables. Be sure that cables are routed in such a way that they cannot be caught or snagged by parts being removed or replaced. Handle flex cables with extreme care; these cables tear easily.

Drive handling

-
- △ **CAUTION:** Drives are fragile components that must be handled with care. To prevent damage to the computer, damage to a drive, or loss of information, observe these precautions:
-

Before removing or inserting a hard drive, shut down the computer. If you are unsure whether the computer is off or in Hibernation, turn the computer on, and then shut it down through the operating system.

Before handling a drive, be sure that you are discharged of static electricity. While handling a drive, avoid touching the connector.

Before removing a diskette drive or optical drive, be sure that a diskette or disc is not in the drive and be sure that the optical drive tray is closed.

Handle drives on surfaces covered with at least one inch of shock-proof foam.

Avoid dropping drives from any height onto any surface.

After removing a hard drive, an optical drive, or a diskette drive, place it in a static-proof bag.

Avoid exposing a hard drive to products that have magnetic fields, such as monitors or speakers.

Avoid exposing a drive to temperature extremes or liquids.

If a drive must be mailed, place the drive in a bubble pack mailer or other suitable form of protective packaging and label the package "FRAGILE."

Grounding guidelines

Electrostatic discharge damage

Electronic components are sensitive to electrostatic discharge (ESD). Circuitry design and structure determine the degree of sensitivity. Networks built into many integrated circuits provide some protection, but in many cases, ESD contains enough power to alter device parameters or melt silicon junctions.

A discharge of static electricity from a finger or other conductor can destroy static-sensitive devices or microcircuitry. Even if the spark is neither felt nor heard, damage may have occurred.

An electronic device exposed to ESD may not be affected at all and can work perfectly throughout a normal cycle. Or the device may function normally for a while, then degrade in the internal layers, reducing its life expectancy.

- △ **CAUTION:** To prevent damage to the computer when you are removing or installing internal components, observe these precautions:

Keep components in their electrostatic-safe containers until you are ready to install them.

Before touching an electronic component, discharge static electricity by using the guidelines described in this section.

Avoid touching pins, leads, and circuitry. Handle electronic components as little as possible.

If you remove a component, place it in an electrostatic-safe container.

The following table shows how humidity affects the electrostatic voltage levels generated by different activities.

- △ **CAUTION:** A product can be degraded by as little as 700 V.

Typical electrostatic voltage levels			
Event	Relative humidity		
	10%	40%	55%
Walking across carpet	35,000 V	15,000 V	7,500 V
Walking across vinyl floor	12,000 V	5,000 V	3,000 V
Motions of bench worker	6,000 V	800 V	400 V
Removing DIPS from plastic tube	2,000 V	700 V	400 V
Removing DIPS from vinyl tray	11,500 V	4,000 V	2,000 V
Removing DIPS from Styrofoam	14,500 V	5,000 V	3,500 V
Removing bubble pack from PCB	26,500 V	20,000 V	7,000 V
Packing PCBs in foam-lined box	21,000 V	11,000 V	5,000 V

Packaging and transporting guidelines

Follow these grounding guidelines when packaging and transporting equipment:

- To avoid hand contact, transport products in static-safe tubes, bags, or boxes.
- Protect ESD-sensitive parts and assemblies with conductive or approved containers or packaging.
- Keep ESD-sensitive parts in their containers until the parts arrive at static-free workstations.
- Place items on a grounded surface before removing items from their containers.
- Always be properly grounded when touching a component or assembly.
- Store reusable ESD-sensitive parts from assemblies in protective packaging or nonconductive foam.
- Use transporters and conveyors made of antistatic belts and roller bushings. Be sure that mechanized equipment used for moving materials is wired to ground and that proper materials are selected to avoid static charging. When grounding is not possible, use an ionizer to dissipate electric charges.

Workstation guidelines

Follow these grounding workstation guidelines:

- Cover the workstation with approved static-shielding material.
- Use a wrist strap connected to a properly grounded work surface and use properly grounded tools and equipment.
- Use conductive field service tools, such as cutters, screwdrivers, and vacuums.
- When fixtures must directly contact dissipative surfaces, use fixtures made only of static-safe materials.
- Keep the work area free of nonconductive materials, such as ordinary plastic assembly aids and Styrofoam.
- Handle ESD-sensitive components, parts, and assemblies by the case or PCM laminate. Handle these items only at static-free workstations.
- Avoid contact with pins, leads, or circuitry.
- Turn off power and input signals before inserting or removing connectors or test equipment.

Equipment guidelines

Grounding equipment must include either a wrist strap or a foot strap at a grounded workstation.

- When seated, wear a wrist strap connected to a grounded system. Wrist straps are flexible straps with a minimum of one megohm $\pm 10\%$ resistance in the ground cords. To provide proper ground, wear a strap snugly against the skin at all times. On grounded mats with banana-plug connectors, use alligator clips to connect a wrist strap.
- When standing, use foot straps and a grounded floor mat. Foot straps (heel, toe, or boot straps) can be used at standing workstations and are compatible with most types of shoes or boots. On conductive floors or dissipative floor mats, use foot straps on both feet with a minimum of one megohm resistance between the operator and ground. To be effective, the conductive strips must be worn in contact with the skin.

The following grounding equipment is recommended to prevent electrostatic damage:

- Antistatic tape
- Antistatic smocks, aprons, and sleeve protectors
- Conductive bins and other assembly or soldering aids
- Nonconductive foam
- Conductive tabletop workstations with ground cords of one megohm resistance
- Static-dissipative tables or floor mats with hard ties to the ground
- Field service kits
- Static awareness labels
- Material-handling packages
- Nonconductive plastic bags, tubes, or boxes
- Metal tote boxes
- Electrostatic voltage levels and protective materials

The following table lists the shielding protection provided by antistatic bags and floor mats.

Material	Use	Voltage protection level
Antistatic plastic	Bags	1,500 V
Carbon-loaded plastic	Floor mats	7,500 V
Metallized laminate	Floor mats	5,000 V

Unknown user password

If the computer you are servicing has an unknown user password, follow these steps to clear the password:



NOTE: These steps also clear CMOS.

1. Shut down the computer. If you are unsure whether the computer is off or in Hibernation, turn the computer on, and then shut it down through the operating system.
2. Disconnect all external devices connected to the computer.
3. Disconnect the power from the computer by first unplugging the power cord from the AC outlet and then unplugging the AC adapter from the computer.
4. Remove the battery (see [Battery on page 46](#)).
5. Remove the real-time clock (RTC) battery (see [RTC battery on page 54](#)).
6. Wait approximately 5 minutes.
7. Replace the RTC battery and reassemble the computer.
8. Connect AC power to the computer. Do not reinsert any batteries at this time.
9. Turn on the computer.

All passwords and all CMOS settings have been cleared.

Component replacement procedures

This chapter provides removal and replacement procedures.

There are as many as 94 screws and screw locks, in 15 different sizes, that must be removed, replaced, or loosened when servicing the computer. Make special note of each screw and screw lock size and location during removal and replacement.

Service tag

The service tag, affixed to the bottom of the computer, provides information that may be needed when troubleshooting system problems. The service tag provides the following information:

- (1) Product name: This is the product name affixed to the front of the computer.
- (2) Serial number (s/n): This is an alphanumeric identifier that is unique to each product.
- (3) Part number/Product number (p/n): This number provides specific information about the product's hardware components. The part number helps a service technician to determine what components and parts are needed.
- (4) Model description: This is the number used to locate documents, drivers, and support for the computer.
- (5) Warranty period: Describes the duration of the warranty period for this computer.

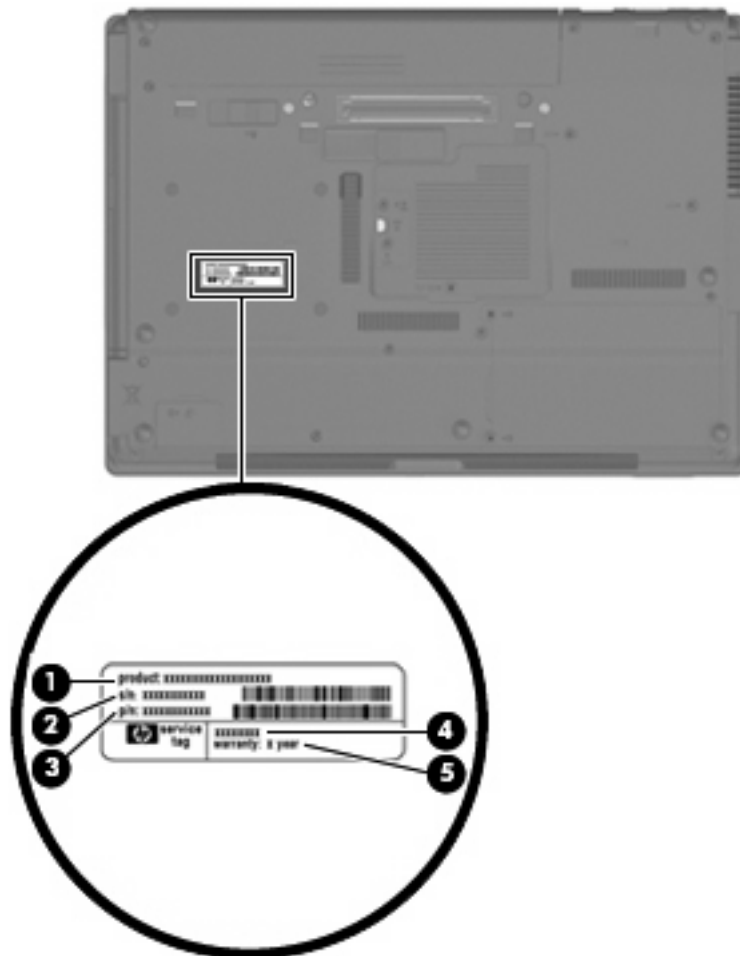

Computer feet

The computer feet are adhesive-backed rubber pads. The feet are included in the Rubber Kit, spare part number 486293001. There are 7 rubber feet that attach to the base enclosure in the locations illustrated below.

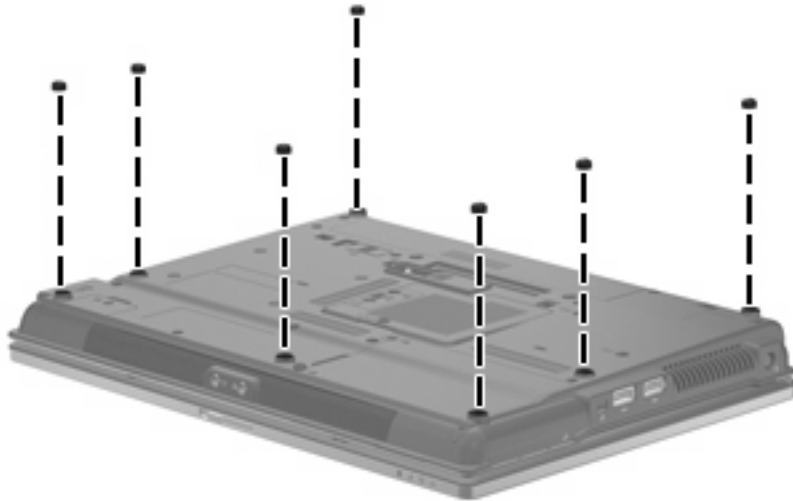

Battery

Description	Spare part number
6-cell, 55-Wh Li-ion battery	486296-001
6-cell, 47-Wh Li-ion battery	486295-001

Before disassembling the computer, follow these steps:

1. Shut down the computer. If you are unsure whether the computer is off or in Hibernation, turn the computer on, and then shut it down through the operating system.
2. Disconnect all external devices connected to the computer.
3. Disconnect the power from the computer by first unplugging the power cord from the AC outlet and then unplugging the AC adapter from the computer.

Remove the battery:

1. Turn the computer upside down on a flat surface, with the battery bay toward you.
2. Slide the battery release latch **(1)** to release the battery.
3. Remove the battery **(2)** from the computer.

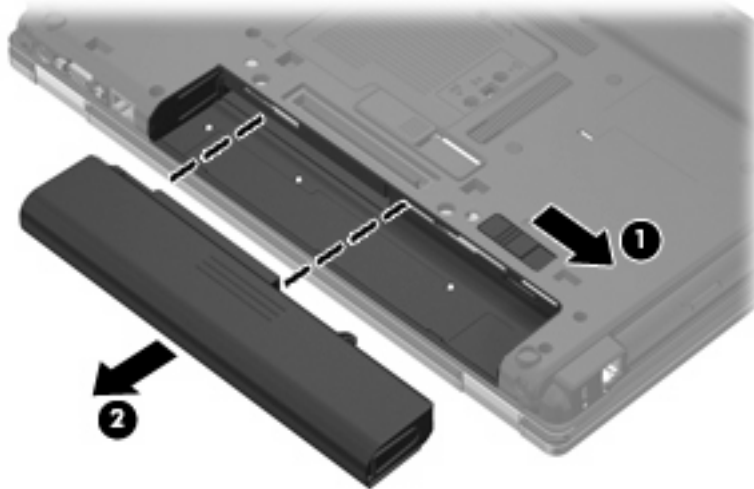

Install the battery by inserting it into the battery bay until you hear a click.

SIM

 **NOTE:** This section applies only to computer models with WWAN capability. If there is a SIM inserted in the SIM slot, it should be removed before disassembling the computer. Be sure the SIM is reinserted in the SIM slot after reassembling the computer.

Before removing the SIM, follow these steps:

1. Shut down the computer. If you are unsure whether the computer is off or in Hibernation, turn the computer on, and then shut it down through the operating system.
2. Disconnect all external devices connected to the computer.
3. Disconnect the power from the computer by first unplugging the power cord from the AC outlet and then unplugging the AC Adapter from the computer.
4. Remove the battery (see [Battery on page 46](#)).

Remove the SIM:

1. Press in on the SIM **(1)**. (The module is partially ejected from the SIM slot.)
2. Remove the SIM **(2)** from the SIM slot.

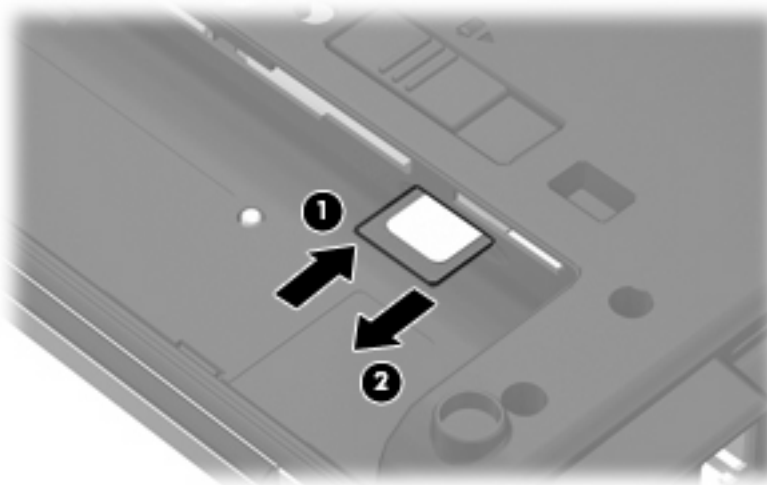

Reverse this procedure to install the SIM.

Display inverter

Description	Spare part number
For use only with HP Compaq 6535b computer models	495086-001
For use only with HP Compaq 6530b computer models	486773-001

Before removing the display inverter, follow these steps:

1. Shut down the computer. If you are unsure whether the computer is off or in Hibernation, turn the computer on, and then shut it down through the operating system.
2. Disconnect all external devices connected to the computer.
3. Disconnect the power from the computer by first unplugging the power cord from the AC outlet and then unplugging the AC Adapter from the computer.
4. Remove the battery (see [Battery on page 46](#)).

Remove the display inverter:

1. Turn the computer right-side up, with the front toward you.
2. Open the computer as far as possible.
3. Remove the two rubber screw covers **(1)** on the bottom edge of the display bezel. The rubber screw covers are available in the Display Rubber Kit, spare part number 486775-001.
4. Remove the two Torx8 T8M2.5×6.0 screws **(2)** that secure the bottom edge of the display bezel to the display enclosure.

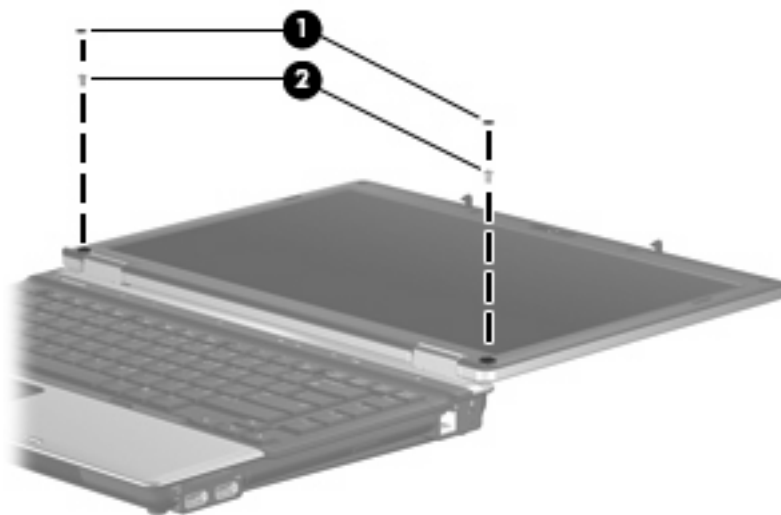

5. Flex the hinge cover areas **(1)** and the bottom edge **(2)** of the display bezel until the bezel disengages from the display enclosure.

6. Release the bottom edge of the display bezel **(3)** from the display assembly.

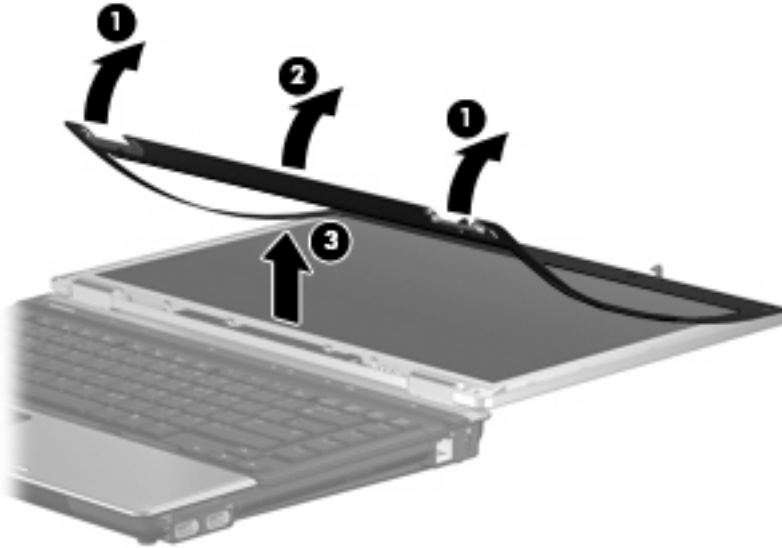

7. Release the inverter **(1)** from the display enclosure as far as the display panel cable and backlight cable allow.
8. Disconnect the display panel cable **(2)** and the backlight cable **(3)** from the display inverter.

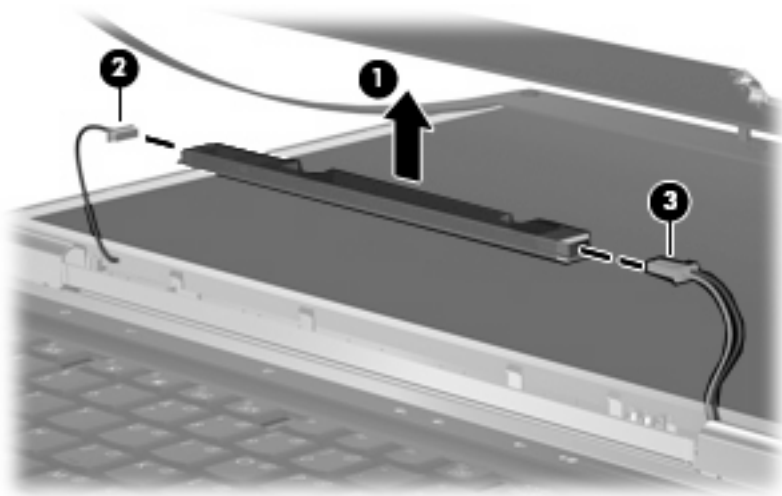

9. Remove the display inverter.

Reverse this procedure to install the display inverter.

Bluetooth module

 **NOTE:** The Bluetooth module spare part kits do not include a Bluetooth module cable. The Bluetooth module cable is included in the Cable Kit, spare part number 486281-001.

Description	Spare part number
For use only with HP Compaq 6535b computer models in all countries and regions except Japan and Asia-Pacific countries and regions	398393-002
For use only with HP Compaq 6535b computer models in Japan and Asia-Pacific countries and regions	450066-001
For use only with HP Compaq 6530b computer models	490809-001

Before removing the Bluetooth module, follow these steps:

1. Shut down the computer. If you are unsure whether the computer is off or in Hibernation, turn the computer on, and then shut it down through the operating system.
2. Disconnect all external devices connected to the computer.
3. Disconnect the power from the computer by first unplugging the power cord from the AC outlet and then unplugging the AC adapter from the computer.
4. Remove the battery (see [Battery on page 46](#)).

Remove the Bluetooth module:

1. Position the computer with the front toward you.
2. Loosen the Phillips PM2.0×5.0 captive screw **(1)** that secures the Bluetooth module compartment cover to the base enclosure.
3. Lift the rear edge of the Bluetooth module compartment cover **(2)**, swing it forward, and remove the cover **(3)**. The Bluetooth module compartment cover is available in the Plastics Kit, spare part number 486292-001.

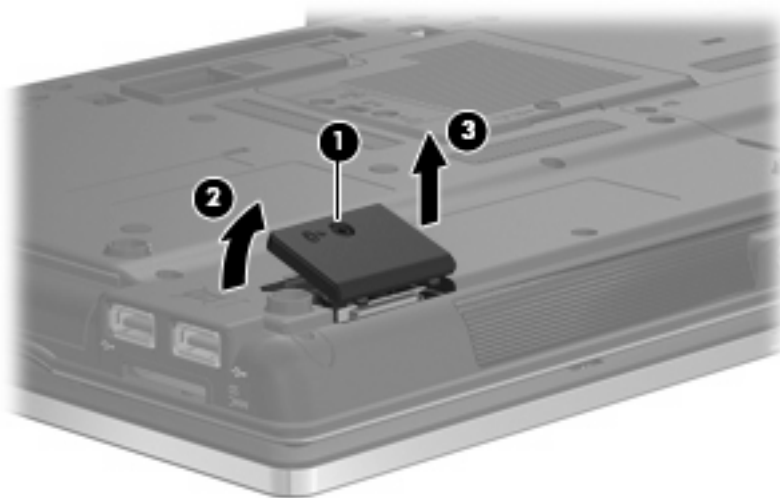

4. Release the Bluetooth module **(1)** from the Bluetooth module compartment as far as the Bluetooth module cable allows.

5. Disconnect the Bluetooth module cable (2) from the Bluetooth module.

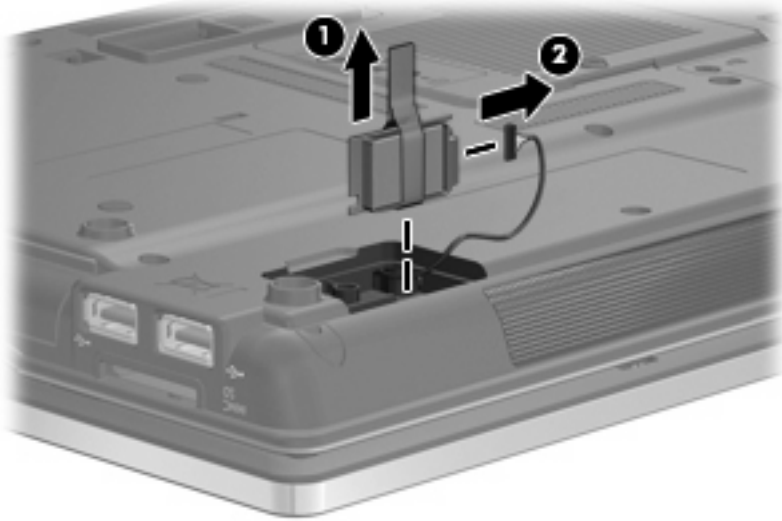

6. Remove the Bluetooth module.

Reverse this procedure to install the Bluetooth module.

Hard drive

 **NOTE:** All hard drive spare part kits include a hard drive bracket.

Description	Spare part number
250-GB, 5400-rpm hard drive	486261-001
160-GB, 5400-rpm hard drive	486260-001
120-GB, 7200-rpm hard drive	486259-001
120-GB, 5400-rpm hard drive	486782-001

Before removing the hard drive, follow these steps:

1. Shut down the computer. If you are unsure whether the computer is off or in Hibernation, turn the computer on, and then shut it down through the operating system.
2. Disconnect all external devices connected to the computer.
3. Disconnect the power from the computer by first unplugging the power cord from the AC outlet and then unplugging the AC adapter from the computer.
4. Remove the battery (see [Battery on page 46](#)).

Remove the hard drive:

1. Position the computer with the front toward you.
2. Loosen the two Phillips PM2.0×5.0 captive screws (1) that secure the hard drive bay cover to the computer.
3. Lift the left side of the hard drive bay cover (2), swing it up and to the right, and remove the cover (3). The hard drive bay cover is included in the Plastics Kit, spare part number 486292-001.

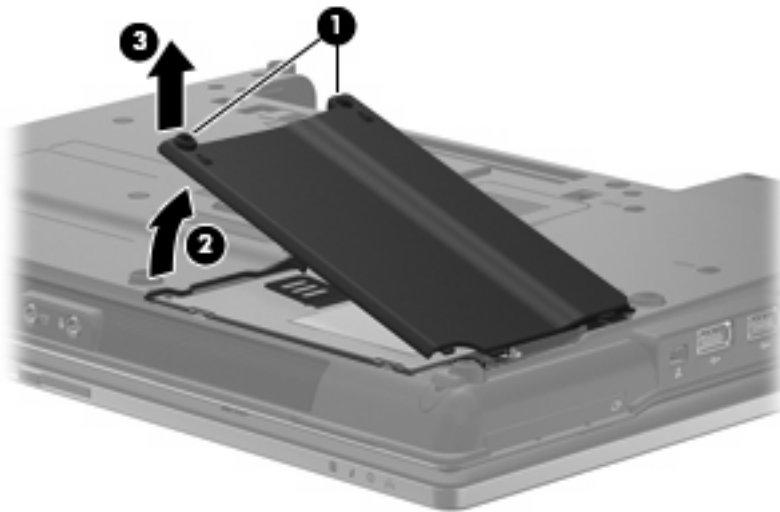

4. Loosen the Phillips PM2.5×10.0 captive screw (1) that secures the hard drive to the computer.

5. Grasp the Mylar tab (2) on the hard drive and slide the hard drive (3) to the left to disconnect it from the system board.
6. Remove the hard drive (4) from the hard drive bay.

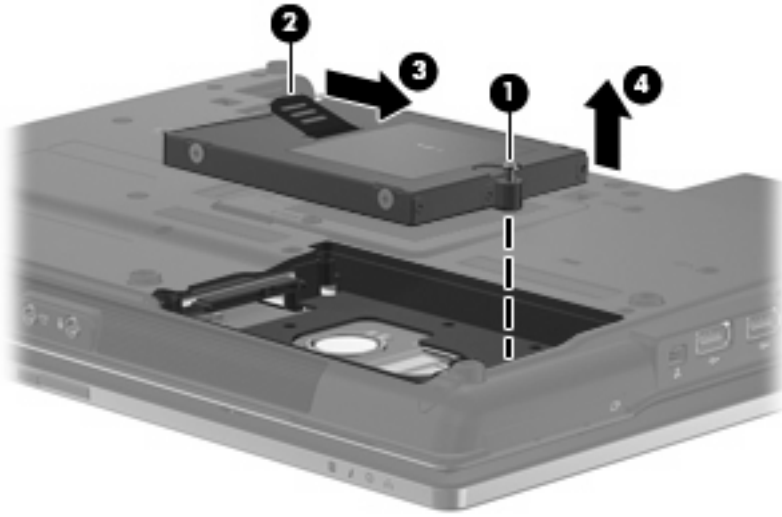

7. If it is necessary to replace the hard drive bracket, remove the two Phillips PM3.0×4.0 hard drive bracket screws (1) from each side of the hard drive.
8. Lift the bracket (2) straight up to remove it from the hard drive.

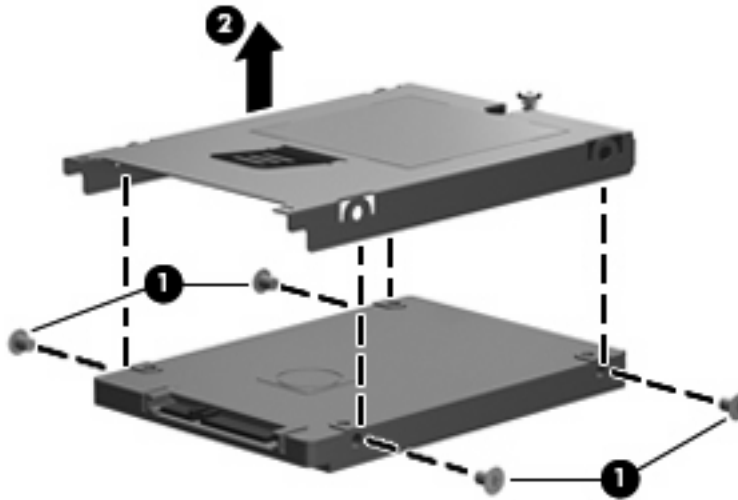

Reverse this procedure to reassemble and install the hard drive.

RTC battery

 **NOTE:** Removing the RTC battery and leaving it uninstalled for 5 or more minutes causes all passwords and CMOS settings to be cleared.

Description	Spare part number
RTC battery	449137-001

Before removing the RTC battery, follow these steps:

1. Shut down the computer. If you are unsure whether the computer is off or in Hibernation, turn the computer on, and then shut it down through the operating system.
2. Disconnect all external devices connected to the computer.
3. Disconnect the power from the computer by first unplugging the power cord from the AC outlet and then unplugging the AC adapter from the computer.
4. Remove the battery (see [Battery on page 46](#)).
5. Remove the hard drive (see [Hard drive on page 52](#)).

Remove the RTC battery:

- Remove the RTC battery from the socket on the system board.

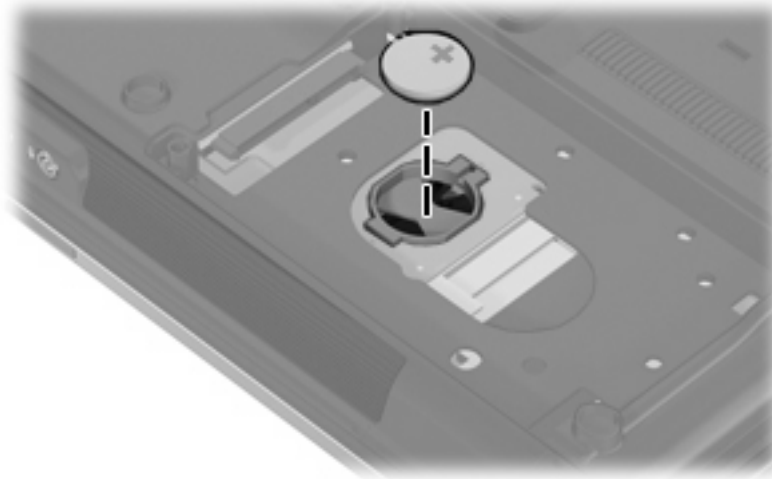

Reverse this procedure to install the RTC battery. When installing the RTC battery, make sure the “+” sign faces up.

Optical drive

 **NOTE:** All optical drive spare part kits include an optical drive bezel.

Description	Spare part number
DVD±RW and CD-RW SuperMulti Double-Layer Combo Drive	486262-001
DVD/CD-RW Combo Drive	486263-001
DVD-ROM Drive	486264-001

Before removing the optical drive, follow these steps:

1. Shut down the computer. If you are unsure whether the computer is off or in Hibernation, turn the computer on, and then shut it down through the operating system.
2. Disconnect all external devices connected to the computer.
3. Disconnect the power from the computer by first unplugging the power cord from the AC outlet and then unplugging the AC adapter from the computer.
4. Remove the battery (see [Battery on page 46](#)).

Remove the optical drive:

1. Position the computer with the front toward you.
2. Remove the Torx T8M2.5×9.0 screw (1) that secures the optical drive to the computer.
3. Insert a flat-bladed screwdriver or similar tool into the optical drive tab access (2) and press the tab to the left to release the optical drive from the computer.
4. Remove the optical drive (3) from the computer.

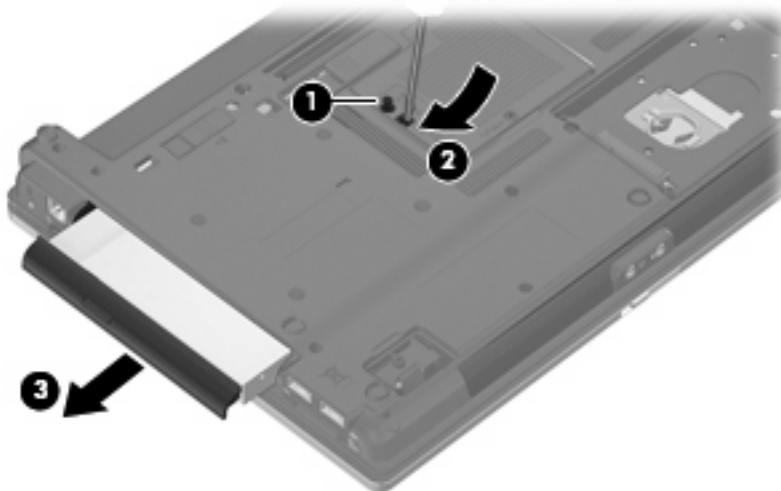

5. If it is necessary to replace the optical drive bracket, position the optical drive with the rear toward you.
6. Remove the two Phillips PM2.0×3.0 screws (1) that secure the optical drive bracket to the optical drive.

7. Remove the optical drive bracket (2).

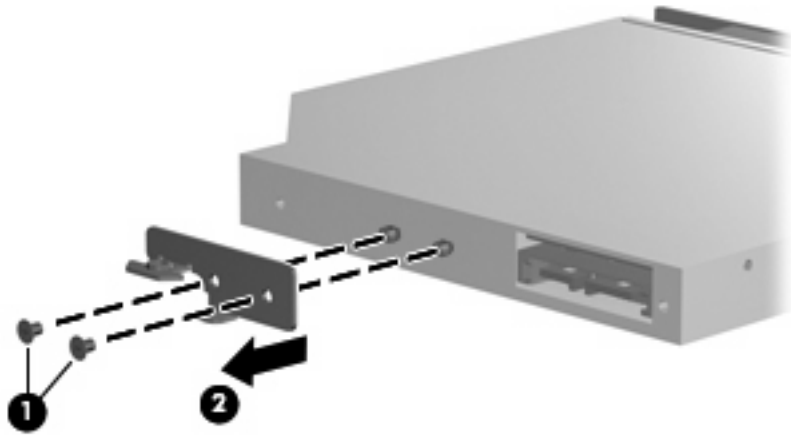

Reverse this procedure to reassemble and install an optical drive.

WLAN module

Description	Spare part number
Broadcom 4322 802.11a/b/g/n WLAN modules:	
<ul style="list-style-type: none">For use in Antigua and Barbuda, Barbados, Belize, Canada, the Cayman Islands, Guam, Puerto Rico, Trinidad and Tobago, the U.S. Virgin Islands, and the United States	487330-001
<ul style="list-style-type: none">For use in Afghanistan, Albania, Algeria, Andorra, Angola, Antigua and Barbuda, Argentina, Armenia, Aruba, Australia, Austria, Azerbaijan, the Bahamas, Bahrain, Bangladesh, Barbados, Belarus, Belgium, Belize, Benin, Bermuda, Bhutan, Bolivia, Bosnia and Herzegovina, Botswana, Brazil, the British Virgin Islands, Brunei, Bulgaria, Burkina Faso, Burundi, Cameroon, Cape Verde, the Central African Republic, Chad, Chile, the People's Republic of China, Colombia, Comoros, the Congo, Costa Rica, Croatia, Cyprus, the Czech Republic, Denmark, Djibouti, Dominica, the Dominican Republic, East Timor, Ecuador, Egypt, El Salvador, Equatorial Guinea, Eritrea, Estonia, Ethiopia, Fiji, Finland, France, French Guiana, Gabon, Gambia, Georgia, Germany, Ghana, Gibraltar, Greece, Grenada, Guadeloupe, Guatemala, Guinea, Guinea-Bissau, Guyana, Haiti, Honduras, Hong Kong, Hungary, Iceland, India, Ireland, Israel, Italy, the Ivory Coast, Jamaica, Jordan, Kazakhstan, Kenya, Kiribati, Kyrgyzstan, Laos, Latvia, Lebanon, Lesotho, Liberia, Liechtenstein, Lithuania, Luxembourg, Macedonia, Madagascar, Malawi, Malaysia, the Maldives, Mali, Malta, the Marshall Islands, Martinique, Mauritania, Mauritius, Mexico, Micronesia, Monaco, Mongolia, Montenegro, Morocco, Mozambique, Namibia, Nauru, Nepal, the Nether Antilles, the Netherlands, New Zealand, Nicaragua, Niger, Nigeria, Norway, Oman, Pakistan, Palau, Panama, Papua New Guinea, Paraguay, Peru, the Philippines, Poland, Portugal, the Republic of Moldova, Romania, Russia, Rwanda, Samoa, San Marino, Sao Tome and Principe, Saudi Arabia, Senegal, Serbia, the Seychelles, Sierra Leone, Singapore, Slovakia, Slovenia, the Solomon Islands, Somalia, South Africa, South Korea, Spain, Sri Lanka, St. Kitts and Nevis, St. Lucia, St. Vincent and the Grenadines, Suriname, Swaziland, Sweden, Switzerland, Taiwan, Tajikistan, Tanzania, Togo, Tonga, Trinidad and Tobago, Tunisia, Turkey, Turkmenistan, Tuvalu, Uganda, Ukraine, the United Arab Emirates, the United Kingdom, Uruguay, Uzbekistan, Vanuatu, Venezuela, Vietnam, Yemen, Zaire, Zambia, and Zimbabwe	487330-002
Broadcom BCM4312 802.11b/g WLAN modules:	
<ul style="list-style-type: none">For use in Canada, the Cayman Islands, Puerto Rico, the U.S. Virgin Islands, Guam, and the United States	490811-001
<ul style="list-style-type: none">For use in Afghanistan, Albania, Algeria, Andorra, Angola, Antigua and Barbuda, Argentina, Armenia, Aruba, Australia, Austria, Azerbaijan, the Bahamas, Bahrain, Bangladesh, Barbados, Belarus, Belgium, Belize, Benin, Bermuda, Bhutan, Bolivia, Bosnia and Herzegovina, Botswana, Brazil, the British Virgin Islands, Brunei, Bulgaria, Burkina Faso, Burundi, Cameroon, Cape Verde, the Central African Republic, Chad, Chile, the People's Republic of China, Colombia, Comoros, the Congo, Costa Rica, Croatia, Cyprus, the Czech Republic, Denmark, Djibouti, Dominica, the Dominican Republic, East Timor, Ecuador, Egypt, El Salvador, Equatorial Guinea, Eritrea, Estonia, Ethiopia, Fiji, Finland, France, French Guiana, Gabon, Gambia, Georgia, Germany, Ghana, Gibraltar, Greece, Grenada, Guadeloupe, Guatemala, Guinea, Guinea-Bissau, Guyana, Haiti, Honduras, Hong Kong, Hungary, Iceland, India, Ireland, Israel, Italy, the Ivory Coast, Jamaica, Jordan, Kazakhstan, Kenya, Kiribati, Kyrgyzstan, Laos, Latvia, Lebanon, Lesotho, Liberia, Liechtenstein, Lithuania, Luxembourg, Macedonia, Madagascar, Malawi, Malaysia, the Maldives, Mali, Malta, the Marshall Islands, Martinique, Mauritania, Mauritius, Mexico, Micronesia, Monaco, Mongolia, Montenegro, Morocco, Mozambique, Namibia, Nauru, Nepal, the Nether Antilles, the Netherlands, New Zealand, Nicaragua, Niger, Nigeria, Norway, Oman, Pakistan, Palau, Panama, Papua New Guinea, Paraguay, Peru, the Philippines, Poland, Portugal, the Republic of Moldova, Romania, Russia, Rwanda, Samoa, San Marino, Sao Tome and Principe, Saudi Arabia, Senegal, Serbia, the Seychelles, Sierra Leone, Singapore, Slovakia, Slovenia, the Solomon Islands, Somalia, South Africa, South Korea, Spain, Sri Lanka, St. Kitts and Nevis, St. Lucia, St. Vincent and the Grenadines, Suriname, Swaziland, Sweden, Switzerland, Taiwan, Tajikistan, Tanzania, Togo, Tonga, Trinidad and Tobago, Tunisia, Turkey, Turkmenistan, Tuvalu, Uganda, Ukraine, the United Arab Emirates, the United Kingdom, Uruguay, Uzbekistan, Vanuatu, Venezuela, Vietnam, Yemen, Zaire, Zambia, and Zimbabwe	490811-002

Before removing the WLAN module, follow these steps:

1. Shut down the computer. If you are unsure whether the computer is off or in Hibernation, turn the computer on, and then shut it down through the operating system.
2. Disconnect all external devices connected to the computer.
3. Disconnect the power from the computer by first unplugging the power cord from the AC outlet and then unplugging the AC adapter from the computer.
4. Remove the battery (see [Battery on page 46](#)).

Remove the WLAN module:

1. Loosen the Phillips PM2.0×5.0 captive screw (1) that secures the memory/WLAN module compartment cover to the computer.
2. Lift the front edge of the memory/WLAN module compartment cover (2), swing it forward, and remove the cover (3). The memory/WLAN module compartment cover is included in the Plastics Kit, spare part number 486292-001.

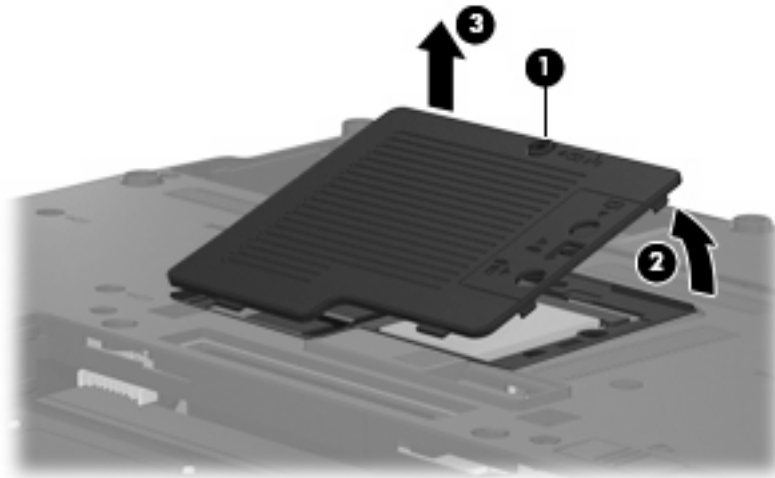

3. Disconnect the WLAN antenna cables (1) from the terminals on the WLAN module.

 **NOTE:** The black WLAN antenna cable is connected to the WLAN module “Main” terminal. The white WLAN antenna cable is connected to the WLAN module “Aux” terminal.

4. Remove the two Phillips PM2.5×4.0 screws (2) that secure the WLAN module to the computer. (The edge of the module opposite the slot rises away from the computer.)

5. Remove the WLAN module (3) by pulling the module away from the slot at an angle.

 **NOTE:** WLAN modules are designed with a notch (4) to prevent incorrect insertion into the WLAN module slot.

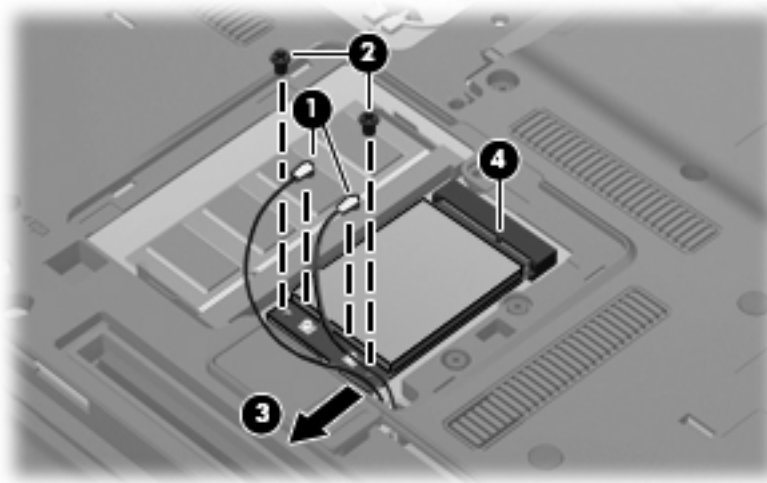

Reverse this procedure to install the WLAN module.

Expansion memory module

Description	Spare part number
2048-MB (PC2-6400, 667-MHz, DDR2)	483193-001
1024-MB (PC2-6400, 667-MHz, DDR2)	483194-001

Before removing the expansion memory module, follow these steps:

1. Shut down the computer. If you are unsure whether the computer is off or in Hibernation, turn the computer on, and then shut it down through the operating system.
2. Disconnect all external devices connected to the computer.
3. Disconnect the power from the computer by first unplugging the power cord from the AC outlet and then unplugging the AC adapter from the computer.
4. Remove the battery (see [Battery on page 46](#)).
5. Remove the memory/WLAN module compartment cover (see [WLAN module on page 57](#)).

Remove the expansion memory module:

1. Spread the retaining tabs (1) on each side of the memory module slot to release the memory module. (The edge of the module opposite the slot rises away from the computer.)

2. Remove the memory module (2) by pulling the module away from the slot at an angle.

 **NOTE:** Memory modules are designed with a notch (3) to prevent incorrect insertion into the memory module slot.

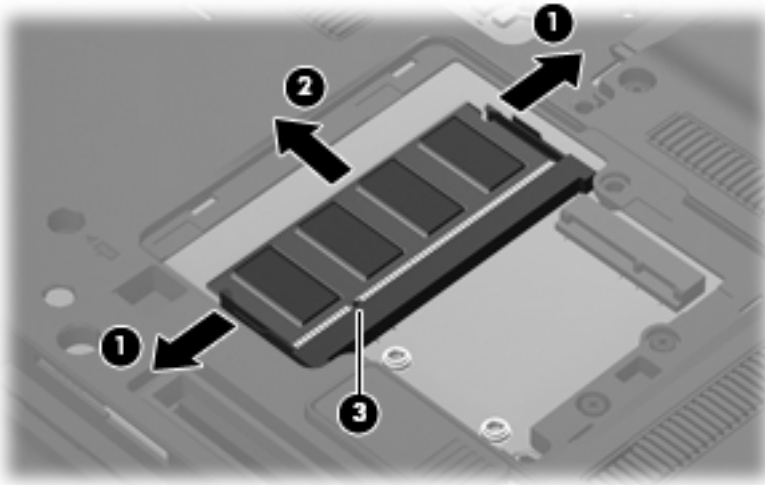

Reverse this procedure to install the expansion memory module.

Keyboard

Country or region	Spare part number	Country or region	Spare part number
Belgium	486279-181	Norway	486279-091
Brazil	486279-201	Portugal	486279-131
The Czech Republic	486279-221	Russia	486279-251
Denmark	486279-081	Saudi Arabia	486279-171
France	486279-051	Slovakia	486279-231
French Canada	486279-121	Slovenia	486279-BA1
Germany	486279-041	South Korea	486279-AD1
Greece	486279-DJ1	Spain	486279-071
Hungary	486279-211	Sweden	486279-B71
Iceland	486279-DD1	Switzerland	486279-BG1
Israel	486279-BB1	Taiwan	486279-AB1
Italy	486279-061	Thailand	486279-281
Japan	486279-291	Turkey	486279-141
Latin America	486279-161	The United Kingdom	486279-031
The Netherlands	486279-B31	The United States	486279-001

Before removing the keyboard, follow these steps:

1. Shut down the computer. If you are unsure whether the computer is off or in Hibernation, turn the computer on, and then shut it down through the operating system.
2. Disconnect all external devices connected to the computer.
3. Disconnect the power from the computer by first unplugging the power cord from the AC outlet and then unplugging the AC adapter from the computer.
4. Remove the battery (see [Battery on page 46](#)).
5. Remove the memory/WLAN module compartment cover (see [WLAN module on page 57](#)).

Remove the keyboard:

1. Loosen the three Phillips PM2.5×9.0 captive screws that secure the keyboard to the computer.

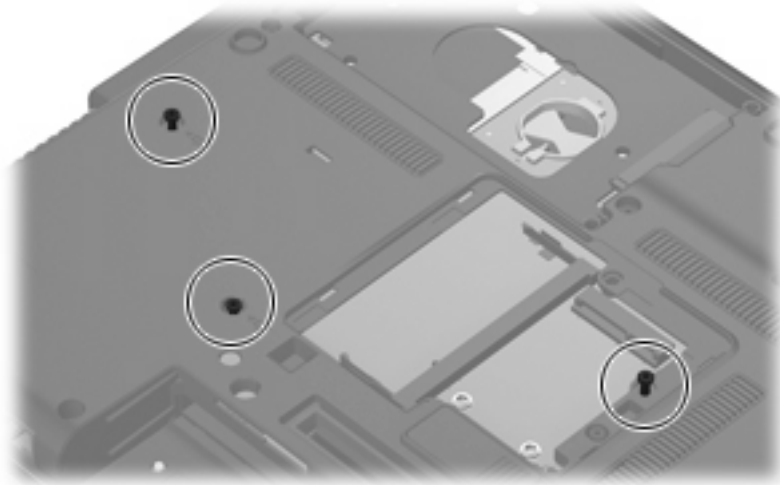

2. Turn the computer display-side up, with the front toward you.
3. Open the computer as far as possible.
4. Slide the four keyboard retention tabs (1) toward you. The tabs are located between the **esc** and **f1** keys, between the **f4** and **f5** keys, between the **f8** and **f9** keys, and between the **f12** and **scroll** keys.
5. Lift the rear edge of the keyboard (2) until it rests at an angle, and slide it back (3) until it rests on the display assembly and switch cover.



6. Release the zero insertion force (ZIF) connector (1) to which the keyboard cable is attached, and disconnect the keyboard cable (2) from the system board.

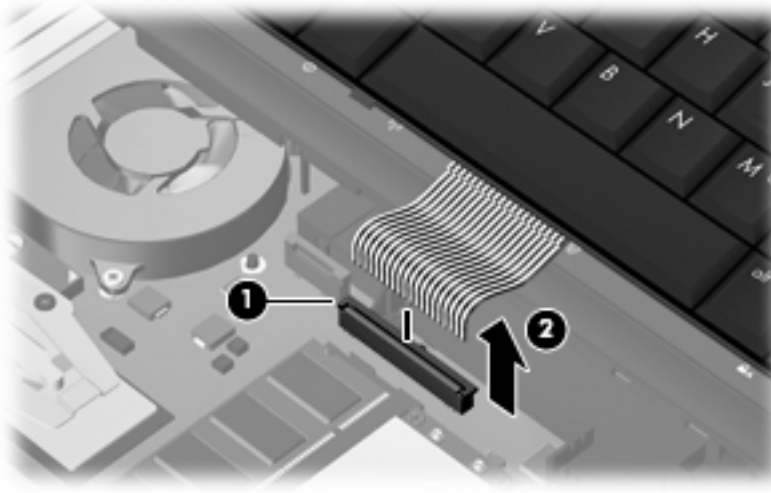

7. Remove the keyboard.

Reverse this procedure to install the keyboard.

Primary memory module

Description	Spare part number
2048-MB (PC2-6400, 667-MHz, DDR2)	483194-001
1024-MB (PC2-6400, 667-MHz, DDR2)	483193-001

Before removing the primary memory module, follow these steps:

1. Shut down the computer. If you are unsure whether the computer is off or in Hibernation, turn the computer on, and then shut it down through the operating system.
2. Disconnect all external devices connected to the computer.
3. Disconnect the power from the computer by first unplugging the power cord from the AC outlet and then unplugging the AC Adapter from the computer.
4. Remove the battery (see [Battery on page 46](#)).
5. Release the keyboard (see [Keyboard on page 61](#)).

Remove the primary memory module:

1. Spread the retaining tabs (1) on each side of the memory module slot to release the memory module. (The edge of the module opposite the slot rises away from the computer.)

2. Remove the memory module (2) by pulling the module away from the slot at an angle.

 **NOTE:** Memory modules are designed with a notch (3) to prevent incorrect insertion into the memory module slot.

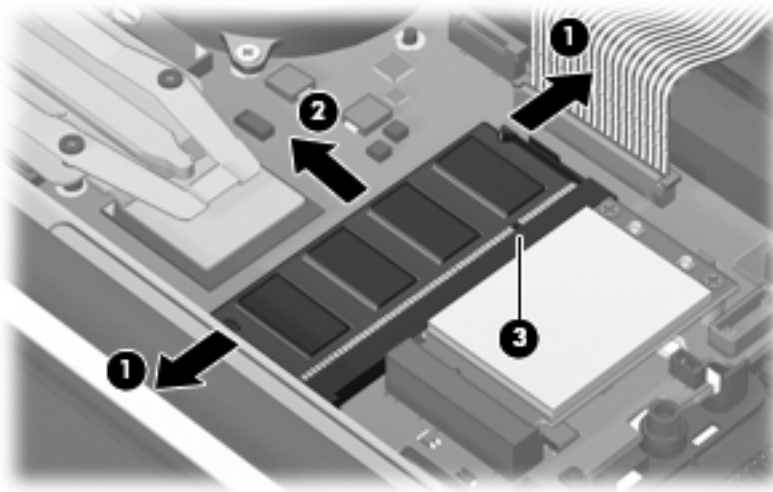

Reverse this procedure to install the primary memory module.

WWAN module

Description	Spare part number
HSDPA EVDO WWAN module	483377-001

Before removing the primary WWAN module, follow these steps:

1. Shut down the computer. If you are unsure whether the computer is off or in Hibernation, turn the computer on, and then shut it down through the operating system.
2. Disconnect all external devices connected to the computer.
3. Disconnect the power from the computer by first unplugging the power cord from the AC outlet and then unplugging the AC Adapter from the computer.
4. Remove the battery (see [Battery on page 46](#)).
5. Release the keyboard (see [Keyboard on page 61](#)).

Remove the WWAN module:

1. Disconnect the WWAN antenna cables (1) from the terminals on the WWAN module.

 **NOTE:** The red WWAN antenna cable is connected to the WWAN module “Main” terminal. The blue WWAN antenna cable is connected to the WWAN module “Aux” terminal.

2. Remove the two Phillips PM2.5×4.0 screws (2) that secure the WWAN module to the computer. (The edge of the module opposite the slot rises away from the computer.)

3. Remove the WWAN module (3) by pulling the module away from the slot at an angle.

 **NOTE:** WWAN modules are designed with a notch (4) to prevent incorrect insertion into the WWAN module slot.

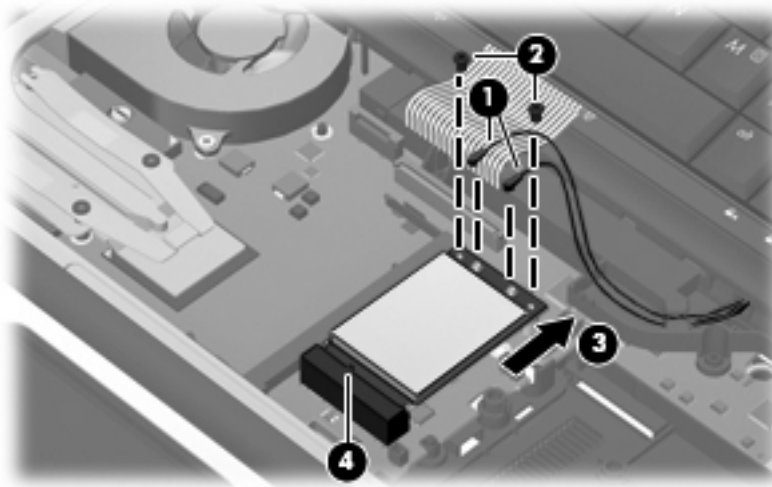

Reverse this procedure to install the WWAN module.

Switch cover

Description	Spare part number
Switch cover (includes power button board and cable and LED board and cable)	486282-001

Before removing the switch cover, follow these steps:

1. Shut down the computer. If you are unsure whether the computer is off or in Hibernation, turn the computer on, and then shut it down through the operating system.
2. Disconnect all external devices connected to the computer.
3. Disconnect the power from the computer by first unplugging the power cord from the AC outlet and then unplugging the AC Adapter from the computer.
4. Remove the battery (see [Battery on page 46](#)).
5. Remove the keyboard (see [Keyboard on page 61](#)).

Remove the switch cover:

1. Release the ZIF connector to which the LED board cable (1) is attached, and disconnect the LED board cable from the system board.
2. Lift the left and right sides of the switch cover (2) until it detaches from the computer.
3. Release the switch cover (3) as far as the power button board cable allows.

4. Disconnect the power button board cable (4) from the system board.

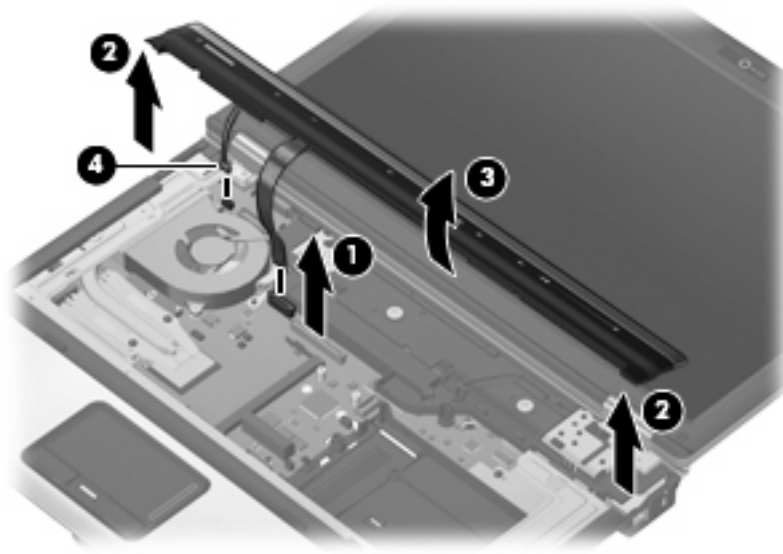

5. Remove the switch cover.

Reverse this procedure to install the switch cover.

Fan

Description	Spare part number
Fan	486288-001

Before removing the fan, follow these steps:

1. Shut down the computer. If you are unsure whether the computer is off or in Hibernation, turn the computer on, and then shut it down through the operating system.
2. Disconnect all external devices connected to the computer.
3. Disconnect the power from the computer by first unplugging the power cord from the AC outlet and then unplugging the AC adapter from the computer.
4. Remove the battery (see [Battery on page 46](#)).
5. Remove the keyboard (see [Keyboard on page 61](#)).
6. Remove the switch cover (see [Switch cover on page 65](#)).

Remove the fan:

1. Disconnect the fan cable (1) from the system board.
2. Loosen the two Phillips PM2.5×7.0 captive screws (2) that secure the fan to the base enclosure.

3. Remove the fan (3).

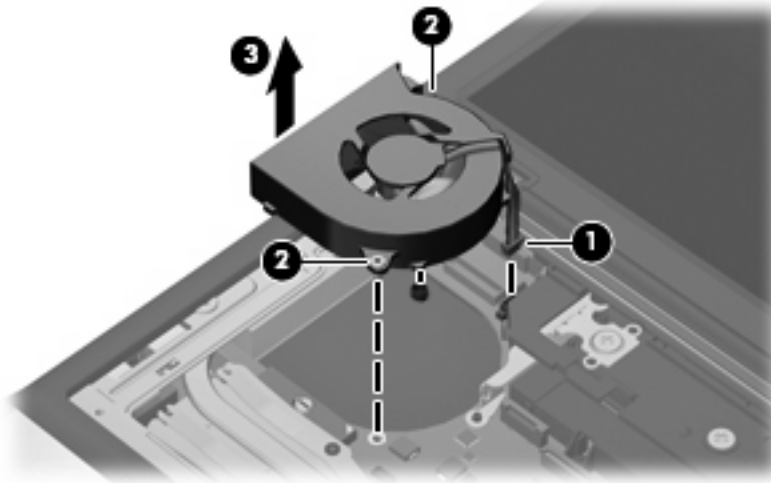

Reverse this procedure to install the fan.

 **NOTE:** To properly ventilate the computer, allow at least a 7.6-cm (3-inch) clearance on the left side of the computer.

The computer uses an electric fan for ventilation. The fan is controlled by a temperature sensor and is designed to turn on automatically when high temperature conditions exist. These conditions are affected by high external temperatures, system power consumption, power management/battery conservation configurations, battery fast charging, and software requirements. Exhaust air is displaced through the ventilation grill located on the left side of the computer.

Heat sink

 **NOTE:** The heat sink spare part kits include replacement thermal material.

Description	Spare part number
For use only with HP Compaq 6535b computer models	488315-001
For use only with HP Compaq 6530b computer models	486289-001

Before removing the heat sink, follow these steps:

1. Shut down the computer. If you are unsure whether the computer is off or in Hibernation, turn the computer on, and then shut it down through the operating system.
2. Disconnect all external devices connected to the computer.
3. Disconnect the power from the computer by first unplugging the power cord from the AC outlet and then unplugging the AC adapter from the computer.
4. Remove the battery (see [Battery on page 46](#)).
5. Remove the keyboard (see [Keyboard on page 61](#)).
6. Remove the fan (see [Fan on page 66](#)).

Remove the heat sink:

 **NOTE:** Steps 1 through 4 apply only to HP Compaq 6530b computer models. See steps 5 through 8 for removing the heat sink on HP Compaq 6535b computer models.

1. Loosen the two Phillips PM2.0×4.0 captive screws (**1**) that secure the heat sink clip to the heat sink.
2. Remove the heat sink clip (**2**) by sliding it to the right, and then lifting it up.

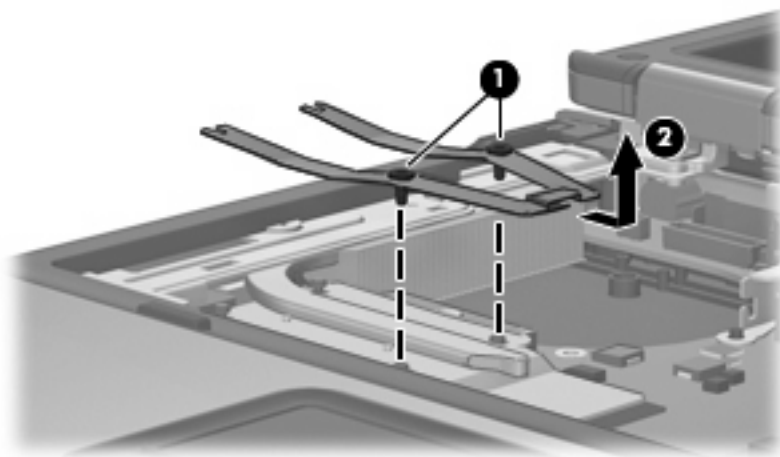

3. Lift the right side of the heat sink (**1**) until it releases from the system board components.

 **NOTE:** Due to the adhesive quality of the thermal material located between the heat sink and system board components, it may be necessary to move the heat sink from side to side to detach it.

4. Remove the heat sink (2) by sliding it to the right.

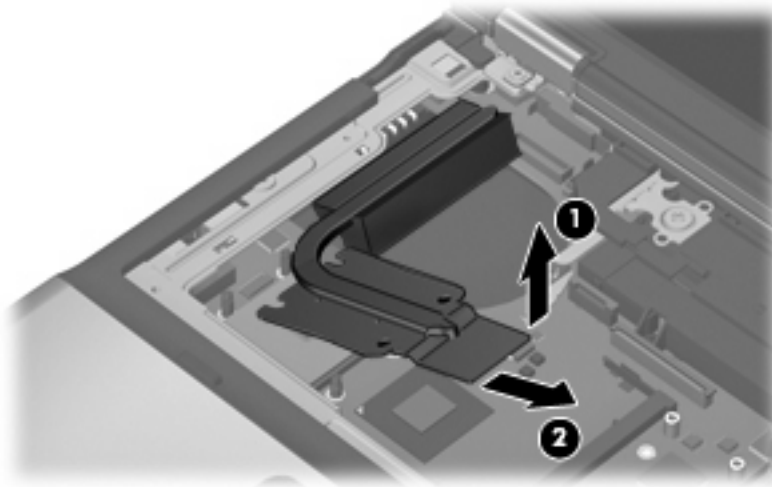

NOTE: The thermal material must be thoroughly cleaned from the surfaces of the heat sink and the system board components each time the heat sink is removed. Thermal pads are used on the Northbridge chip (1) and the section of the heat sink (1) that services it. Thermal paste is used on the processor (2) and the section of the heat sink (2) that services it. Replacement thermal material is included with all heat sink, system board, and processor spare part kits.

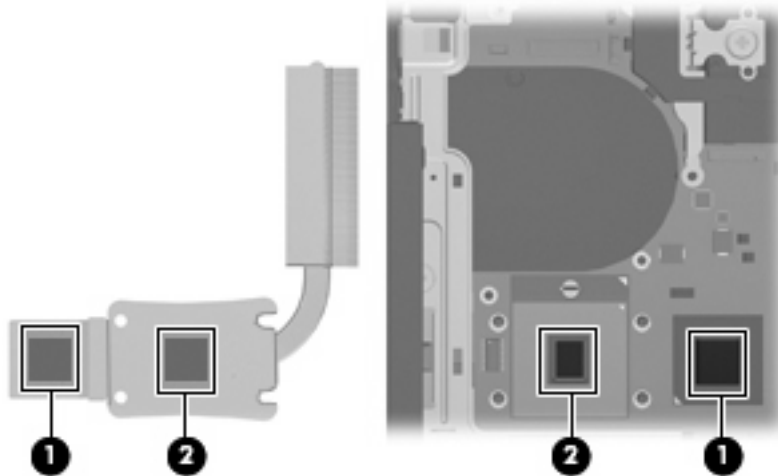

NOTE: Steps 5 through 8 apply only to HP Compaq 6535b computer models. See steps 1 through 4 for removing the heat sink on HP Compaq 6530b computer models.

5. Remove the two Phillips PM2.0×4.0 screws (1) that secure the heat sink clips to the heat sink.

6. Remove the heat sink clips (2) by sliding them to left, and then lifting them up.

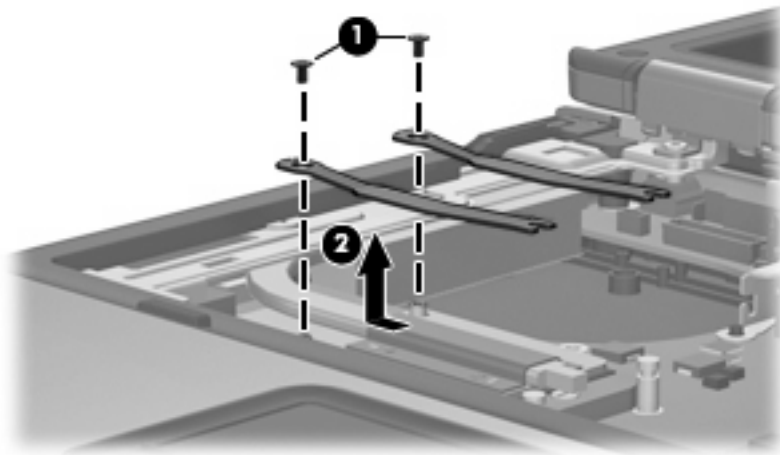

7. Lift the right side of the heat sink (1) until it releases from the system board components.

 **NOTE:** Due to the adhesive quality of the thermal material located between the heat sink and system board components, it may be necessary to move the heat sink from side to side to detach it.

8. Remove the heat sink (2) by sliding it to the right.

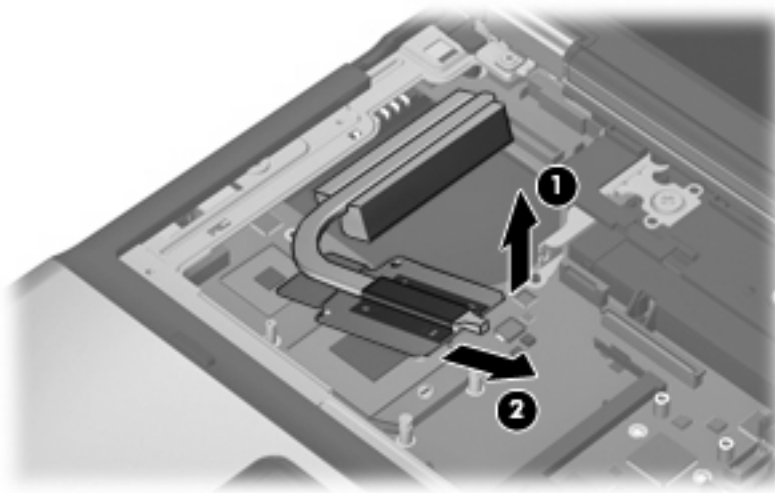

 **NOTE:** The thermal material must be thoroughly cleaned from the surfaces of the heat sink and the system board components each time the heat sink is removed. Thermal paste is used on the processor (1) and the section of the heat sink (1) that services it. Thermal pads are used on the Northbridge chip (2) and the section of the heat sink (2) that services it. Replacement thermal material is included with all heat sink, system board, and processor spare part kits.

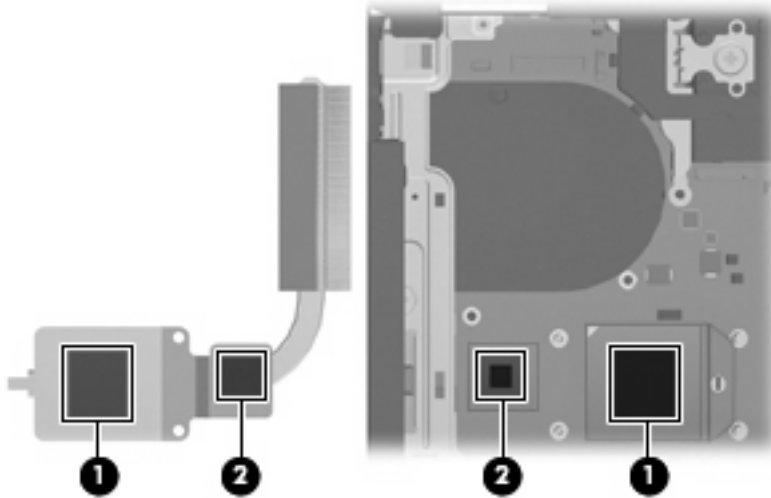

Reverse this procedure to install the heat sink.

Processor

 **NOTE:** All processor spare part kits include replacement thermal material.

Description	Spare part number
AMD processors for use only with HP Compaq 6535b computer models:	
Turion 64 ZM-86 2.40-GHz processor	488198-001
Turion 64 ZM-82 2.20-GHz processor	488196-001
Turion 64 ZM-80 2.10-GHz processor	488195-001
Turion 64 RM-70 2.00-GHz processor	488199-001
Sempron SI-40 2.00-GHz processor	488197-001
Athlon QL-60 1.90-GHz processor	488200-001
Intel processors for use only with HP Compaq 6530b computer models:	
Intel Core2 Duo T9600 2.80-GHz processor (6-MB L2 cache, 800-MHz FSB)	486257-001
Intel Core2 Duo T9400 2.53-GHz processor (6-MB L2 cache, 800-MHz FSB)	486256-001
Intel Core2 Duo T8600 2.40-GHz processor (3-MB L2 cache, 800-MHz FSB)	486255-001
Intel Core2 Duo T8400 2.26-GHz processor (3-MB L2 cache, 800-MHz FSB)	486254-001

Before removing the processor, follow these steps:

1. Shut down the computer. If you are unsure whether the computer is off or in Hibernation, turn the computer on, and then shut it down through the operating system.
2. Disconnect all external devices connected to the computer.
3. Disconnect the power from the computer by first unplugging the power cord from the AC outlet and then unplugging the AC adapter from the computer.
4. Remove the battery (see [Battery on page 46](#)).
5. Remove the following components:
 - a. Keyboard (see [Keyboard on page 61](#))
 - b. Switch cover (see [Switch cover on page 65](#))
 - c. Fan (see [Fan on page 66](#))
 - d. Heat sink (see [Heat sink on page 68](#))

Remove the processor:

 **NOTE:** Steps 1 and 2 apply only to HP Compaq 6530b computer models. See steps 3 and 4 for instructions on removing the processor on HP Compaq 6535b computer models.

1. Use a flat-bladed screwdriver to turn the processor locking screw **(1)** one-half turn counterclockwise until you hear a click.

- Lift the processor (2) straight up and remove it.

 **NOTE:** When you install the processor, the gold triangle (3) on the processor must be aligned with the triangle (4) embossed on the processor slot.

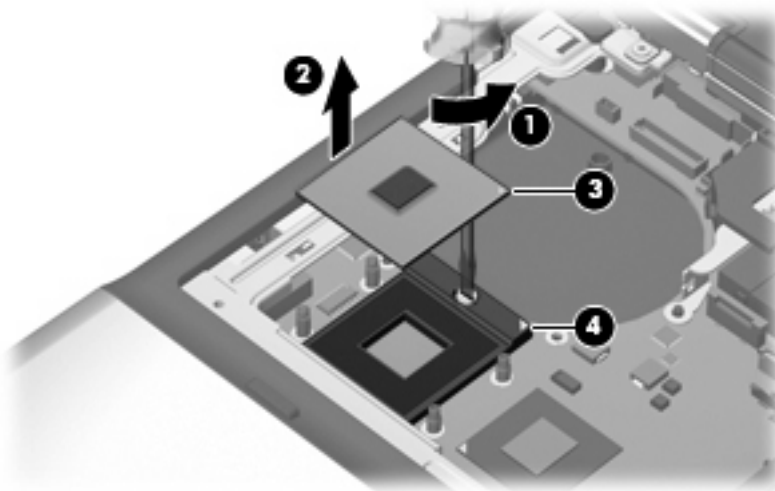

 **NOTE:** Steps 3 and 4 apply only to HP Compaq 6535b computer models. See steps 1 and 2 for instructions on removing the processor on HP Compaq 6530b computer models.

- Use a flat-bladed screwdriver to turn the processor locking screw (1) one-half turn counterclockwise until you hear a click.
- Lift the processor (2) straight up and remove it.

 **NOTE:** When you install the processor, the gold triangle (3) on the processor must be aligned with the triangle (4) embossed on the processor slot.

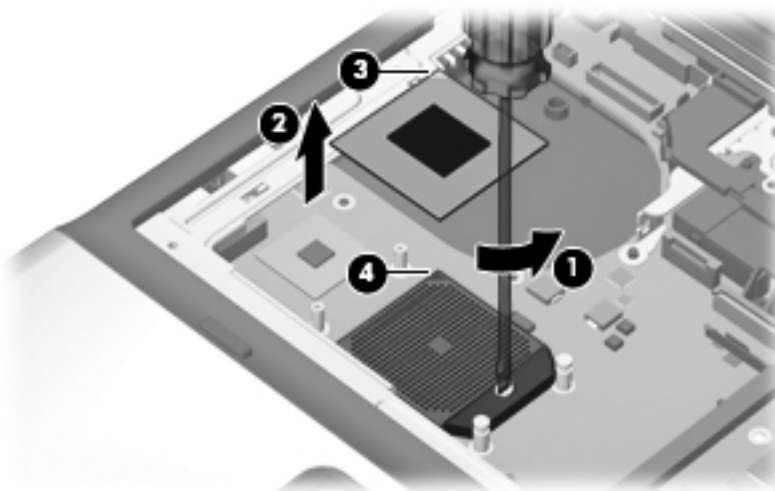

Reverse this procedure to install the processor.

Display assembly

 **NOTE:** All display assembly spare part kits include 2 WLAN antenna transceivers and cables.

Description	Spare part number
For use only with HP Compaq 6535b computer models equipped with both WLAN and WWAN modules	
14.1-inch WXGA BrightView display assembly with 2 microphones and webcam	492169-001
14.1-inch WXGA BrightView display assembly with 1 microphone	492170-001
14.1-inch WXGA+ display assembly with 2 microphones and webcam	492165-001
14.1-inch WXGA+ display assembly with 1 microphone	492166-001
14.1-inch WXGA display assembly with 2 microphones and webcam	492161-001
14.1-inch WXGA display assembly with 1 microphone	492162-001
For use only with HP Compaq 6535b computer models equipped with a WLAN and no WLAN module	
14.1-inch WXGA BrightView display assembly with 2 microphones and webcam	492171-001
14.1-inch WXGA BrightView display assembly with 1 microphone	492172-001
14.1-inch WXGA+ display assembly with 2 microphones and webcam	492167-001
14.1-inch WXGA+ display assembly with 1 microphone	192168-001
14.1-inch WXGA display assembly with 2 microphones and webcam	492163-001
14.1-inch WXGA display assembly with 1 microphone	492164-001
For use only with HP Compaq 6530b computer models equipped with both WLAN and WWAN modules	
14.1-inch WXGA BrightView display assembly with 2 microphones and webcam	486273-001
14.1-inch WXGA BrightView display assembly with 1 microphone	486274-001
14.1-inch WXGA+ display assembly with 2 microphones and webcam	486269-001
14.1-inch WXGA+ display assembly with 1 microphone	486270-001
14.1-inch WXGA display assembly with 2 microphones and webcam	486265-001
14.1-inch WXGA display assembly with 1 microphone	486266-001
For use only with HP Compaq 6530b computer models equipped with a WLAN module and no WWAN module	
14.1-inch WXGA BrightView display assembly with 2 microphones and webcam	486275-001
14.1-inch WXGA BrightView display assembly with 1 microphone	486276-001
14.1-inch WXGA+ display assembly with 2 microphones and webcam	486271-001
14.1-inch WXGA+ display assembly with 1 microphone	486272-001
14.1-inch WXGA display assembly with 2 microphones and webcam	486267-001
14.1-inch WXGA display assembly with 1 microphone	486268-001

Before removing the display assembly, follow these steps:

1. Shut down the computer. If you are unsure whether the computer is off or in Hibernation, turn the computer on, and then shut it down through the operating system.
2. Disconnect all external devices connected to the computer.
3. Disconnect the power from the computer by first unplugging the power cord from the AC outlet and then unplugging the AC adapter from the computer.
4. Remove the battery (see [Battery on page 46](#)).
5. Disconnect the wireless antenna cables from the WLAN module (see [WLAN module on page 57](#)).
6. Remove the keyboard (see [Keyboard on page 61](#)).
7. Remove the switch cover (see [Switch cover on page 65](#)).

Remove the display assembly:

1. Close the computer and turn it upside down, with the rear panel toward you.
2. Remove the Torx T8M2.5×9.0 screw **(1)** that secures the display assembly to the computer.
3. Remove the four Torx T8M2.5×9.0 screws **(2)** that secure the display assembly to the computer.

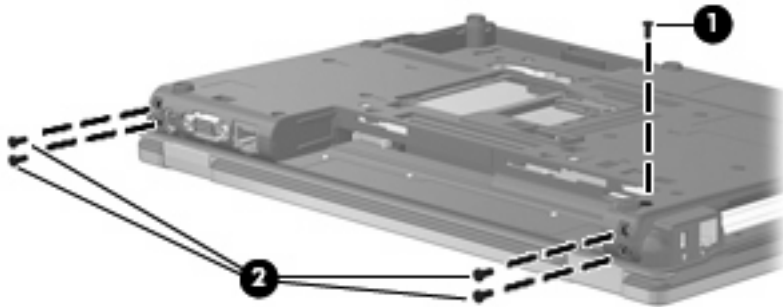

4. Turn the computer right-side up, with the front toward you.
 5. Open the computer as far as possible.
- △ **CAUTION:** The display assembly will be unsupported when the left and right hinge cover screws are removed. To prevent damage to the display assembly, support it before removing the screws.
6. Remove the Phillips PM2.5×4.0 screw **(1)** that secures the left hinge cover to the computer.
 7. Remove the left hinge cover **(2)**. The display hinge covers are available using spare part number 486287-001.
 8. Disconnect the display panel cable **(3)** from the system board.

9. Disconnect the microphone extension cable (4) from the system board.

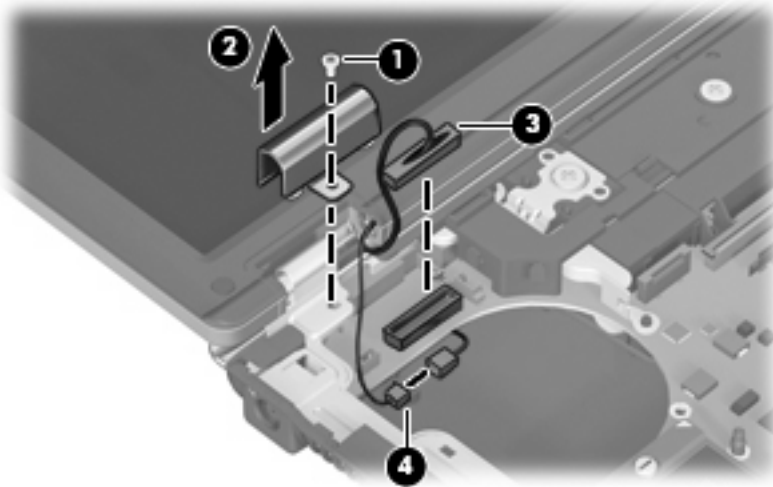

10. Remove the Phillips PM2.5×4.0 screw (1) that secures the right hinge cover to computer.
11. Remove the right hinge cover (2). The display hinge covers are available using spare part number 486287-001.
12. Disconnect the webcam cable (3) from the system board.
13. Remove the wireless antenna cables (4) from the clips (5) and routing channels built into the top cover.

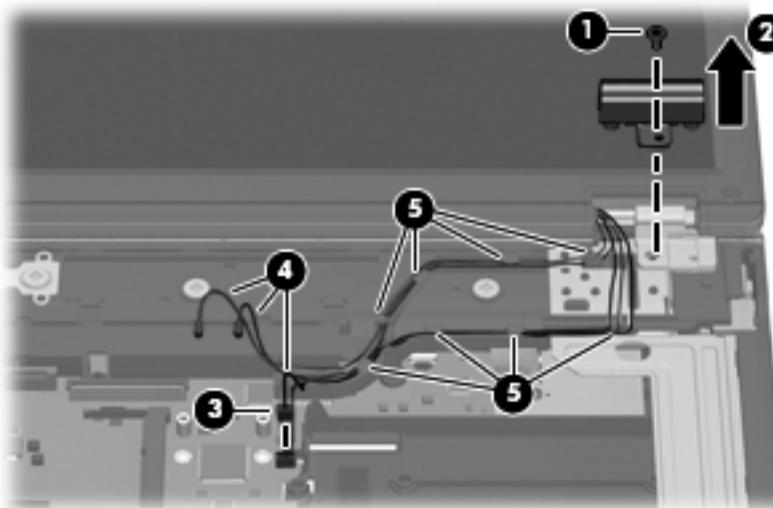

14. Lift the display assembly straight up and remove it.

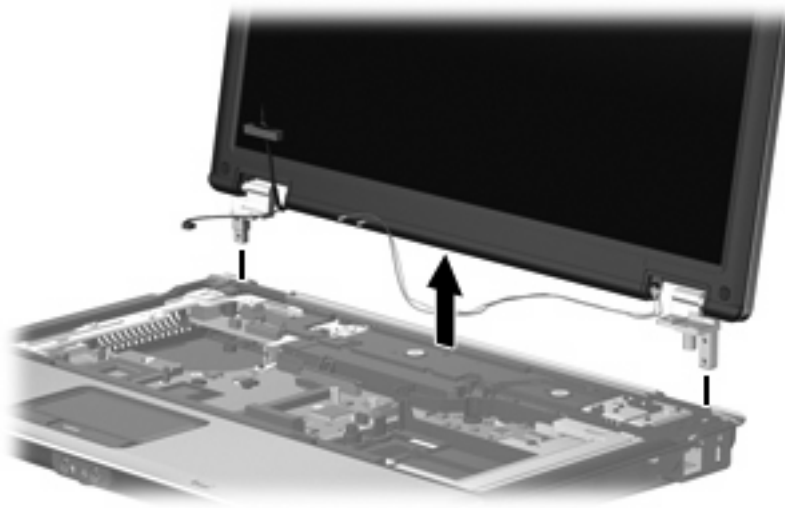

15. If it is necessary to replace the display bezel, display panel, or display hinges, remove the following:

 **NOTE:** See [Display inverter on page 48](#) for instructions on replacing the display inverter.

(1) Four beveled rubber screw covers on the display bezel top edge.

(2) Two flat rubber screw covers on the display bezel bottom edge.

 **NOTE:** The display bezel rubber screw covers are available in the Display Rubber Kit, spare part number 486775-001.

(3) Six Torx T8M2.5×6.0 screws.

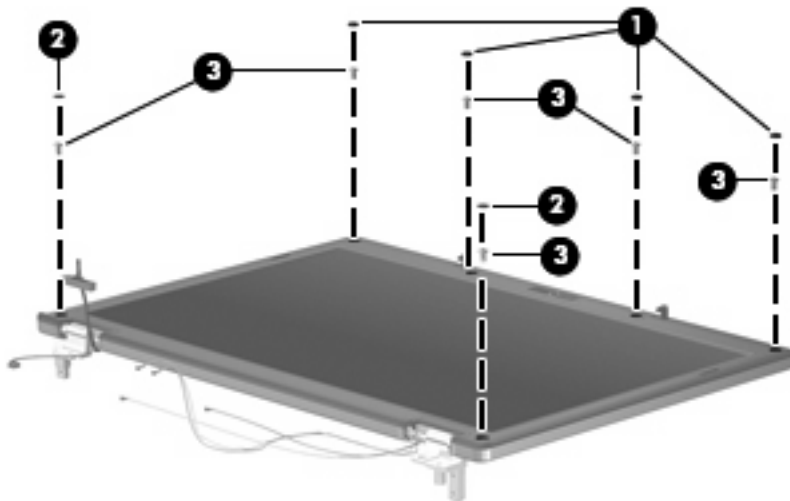

16. Flex the inside edges of the left and right sides (1) and the top and bottom sides (2) of the display bezel until the bezel disengages from the display enclosure.

17. Remove the display bezel (3). The display bezel is available using spare part numbers 486770-001 (for use with computer models equipped with a webcam) and 487339-001 (for use with computer models not equipped with a webcam).

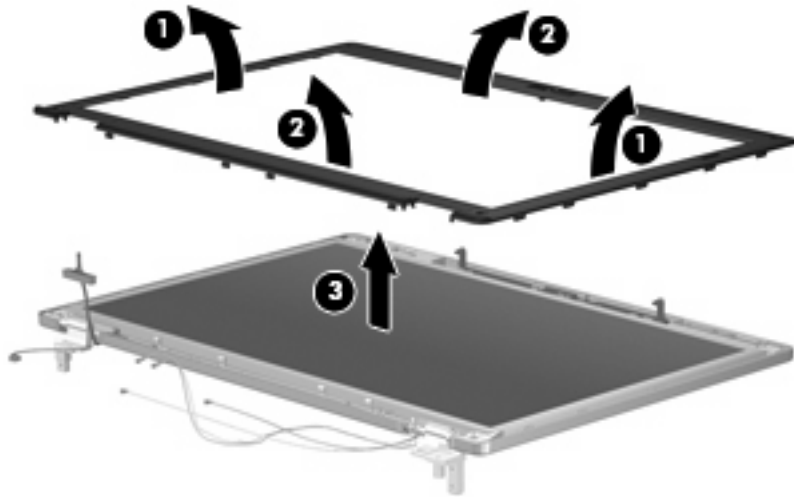

18. If it is necessary to replace the display hinges, remove the four Torx T8M2.5×6.0 screws (1) that secure the display panel to the display enclosure.
19. Remove the display panel (2).

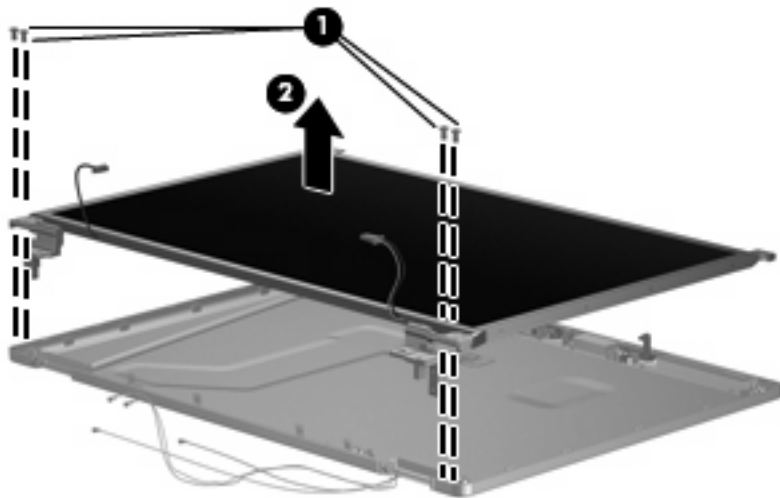

20. Remove the four Phillips PM2.0×3.0 screws (1) that secure each display hinge to the display panel.

21. Remove the display hinges (2). The left and right display hinges are available using spare part number 486772-001.

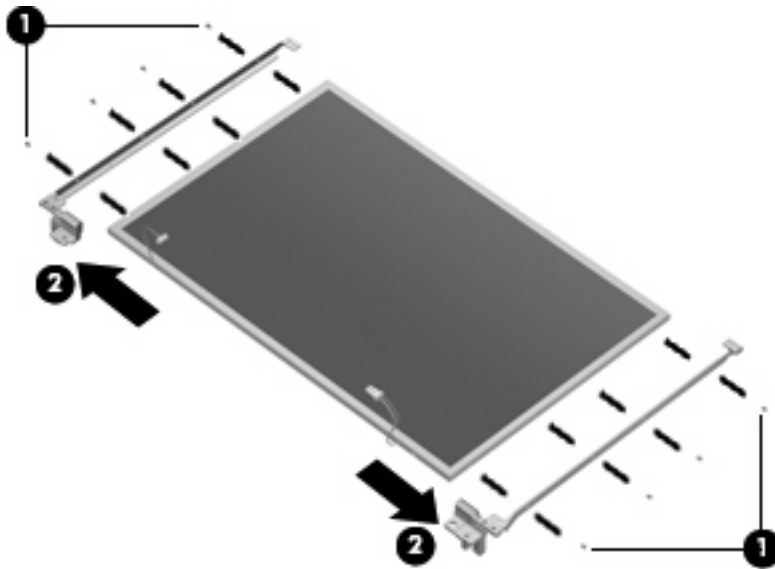

22. If it is necessary to replace the WLAN antenna transceivers and cables, detach the WLAN antenna transceivers (1) from the display enclosure. The WLAN antenna transceivers are attached to the display enclosure with double-sided tape.
23. Remove the WLAN antenna cables from the clips (2) built into the left and right sides of the display enclosure.

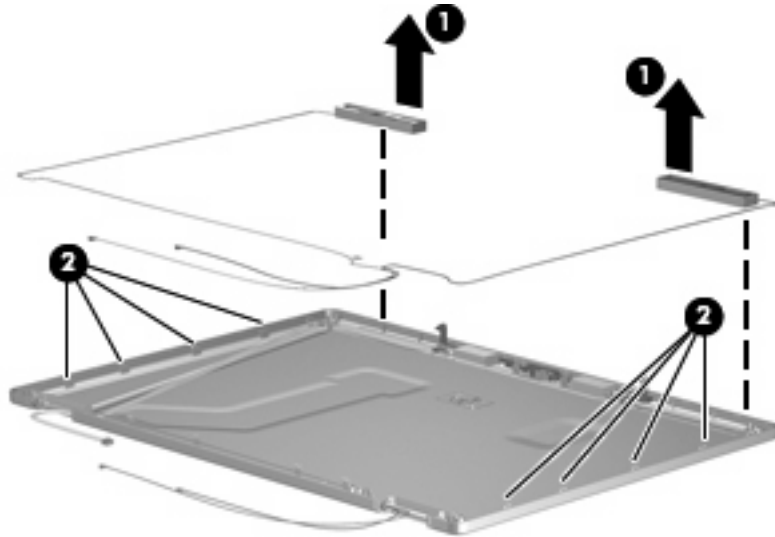

24. Remove the WLAN antenna transceivers and cables. The WLAN antenna transceivers and cables are available using spare part number 486777-001.
25. If it is necessary to replace the WWAN antenna transceivers and cables, detach the WWAN antenna transceivers (1) from the display enclosure. The WWAN antenna transceivers are attached to the display enclosure with double-sided tape.

26. Remove the WWAN antenna cables from the clips (2) built into the left and right sides of the display enclosure.

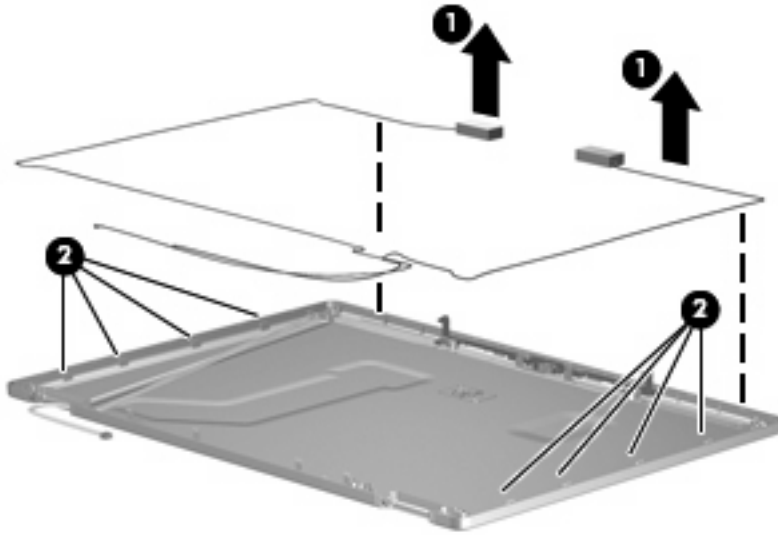

27. Remove the WWAN antenna transceivers and cables. The WWAN antenna transceivers and cables are available using spare part number 486778-001.

Reverse this procedure to reassemble and install the display assembly.

Top cover

Description	Spare part number
Top cover	486283-001

Before removing the top cover, follow these steps:

1. Shut down the computer. If you are unsure whether the computer is off or in Hibernation, turn the computer on, and then shut it down through the operating system.
2. Disconnect all external devices connected to the computer.
3. Disconnect the power from the computer by first unplugging the power cord from the AC outlet and then unplugging the AC adapter from the computer.
4. Remove the battery (see [Battery on page 46](#)).
5. Remove the following components:
 - a. Hard drive (see [Hard drive on page 52](#))
 - b. Optical drive (see [Optical drive on page 55](#))
 - c. Keyboard (see [Switch cover on page 65](#))
 - d. Switch cover (see [Switch cover on page 65](#))
 - e. Display assembly (see [Display assembly on page 74](#))

Remove the top cover:

1. Turn the computer upside down, with the front toward you.
2. Remove the two rubber screw covers (1) and the seven Torx T8M2.5×9.0 screws (2) that secure the top cover to the computer. The rubber screw covers are available in the Rubber Kit, spare part number 486293-001.

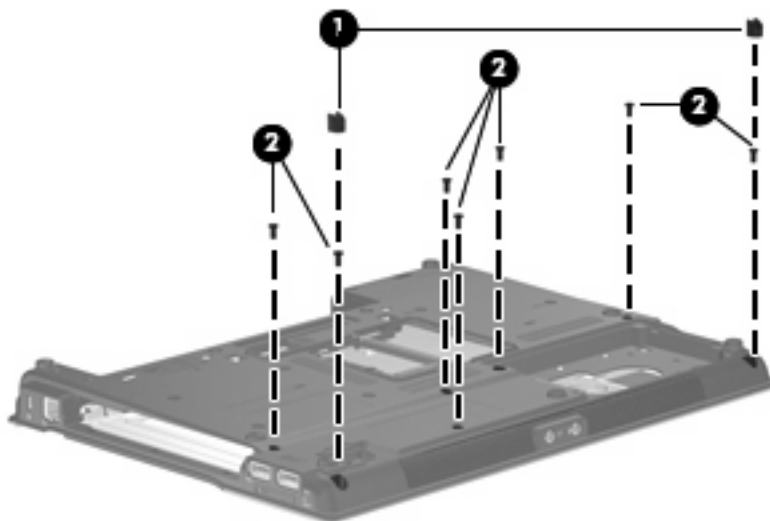

3. Remove the three Phillips PM2.0×3.0 screws that secure the top cover to the computer.

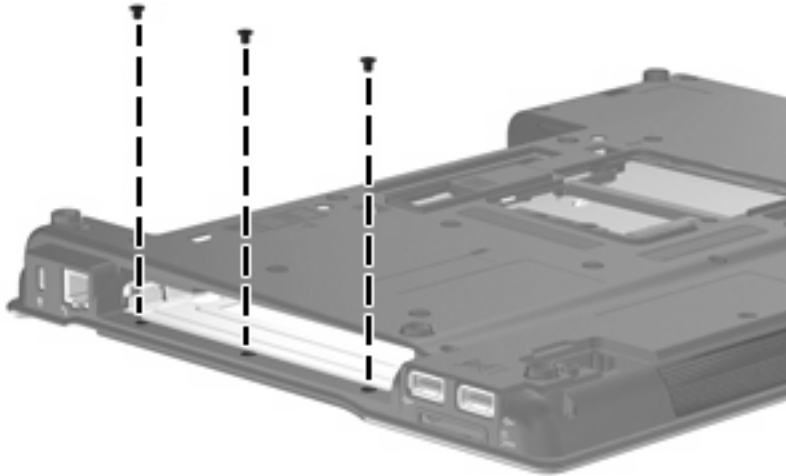

4. Turn the computer right side up, with the front toward you.
5. Lift the rear edge of the top cover and swing it up and forward until it rests at an angle.

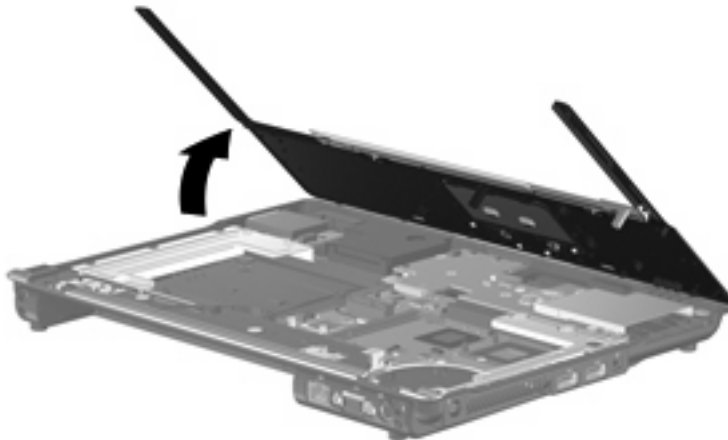

6. Release the ZIF connector to which the TouchPad board cable (1) is attached, and disconnect the TouchPad board cable from the system board.

 **NOTE:** The fingerprint reader board is available only on select models.

7. Disconnect the fingerprint reader board cable (2) from the system board.

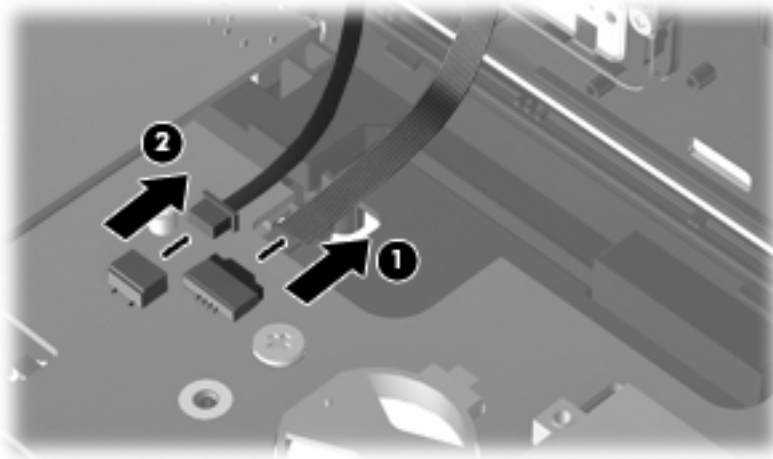

8. Remove the top cover.

Reverse this procedure to install the top cover.

TouchPad board

Description	Spare part number
For use only with computer models equipped with a fingerprint reader (includes a TouchPad bracket and a fingerprint reader board and cable)	486278-001
For use only with computer models not equipped with a fingerprint reader (includes a TouchPad bracket)	486277-001

Before removing the TouchPad board, follow these steps:

1. Shut down the computer. If you are unsure whether the computer is off or in Hibernation, turn the computer on, and then shut it down through the operating system.
2. Disconnect all external devices connected to the computer.
3. Disconnect the power from the computer by first unplugging the power cord from the AC outlet and then unplugging the AC Adapter from the computer.
4. Remove the battery (see [Battery on page 46](#)).
5. Remove the following:
 - a. Hard drive (see [Hard drive on page 52](#))
 - b. Optical drive (see [Optical drive on page 55](#))
 - c. Keyboard (see [Keyboard on page 61](#))
 - d. Switch cover (see [Switch cover on page 65](#))
 - e. Display assembly (see [Display assembly on page 74](#))
 - f. Top cover (see [Top cover on page 81](#))

Remove the TouchPad board:

1. Turn the top cover upside down, with the front toward you.
2. Remove the six Phillips PM2.0×3.0 screws that secure the TouchPad bracket to the top cover.

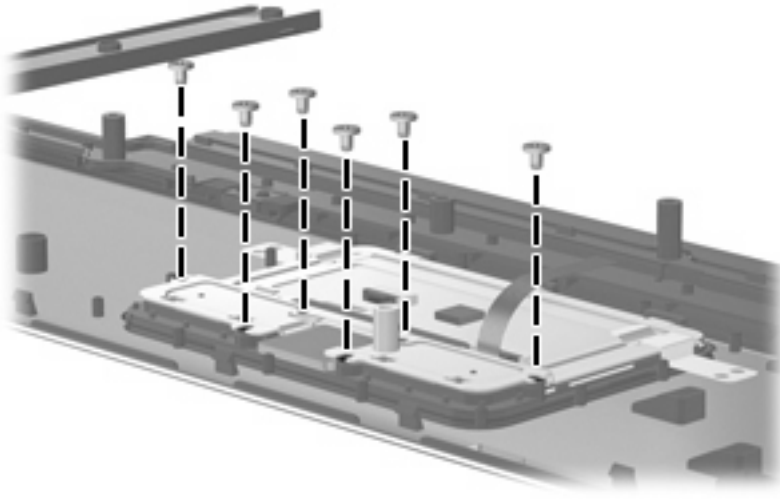

△ **CAUTION:** When removing the TouchPad bracket, be sure that the fingerprint reader board cable (1) is removed through the opening in the TouchPad bracket. Failure to follow this caution may result in damage to the fingerprint reader board cable.

📄 **NOTE:** The fingerprint reader board cable is present only on computer models equipped with a fingerprint reader.

3. Release the TouchPad bracket (2) by sliding it forward until the bracket clears the spring clips (3) built into the top cover.
4. Remove the TouchPad bracket (4).

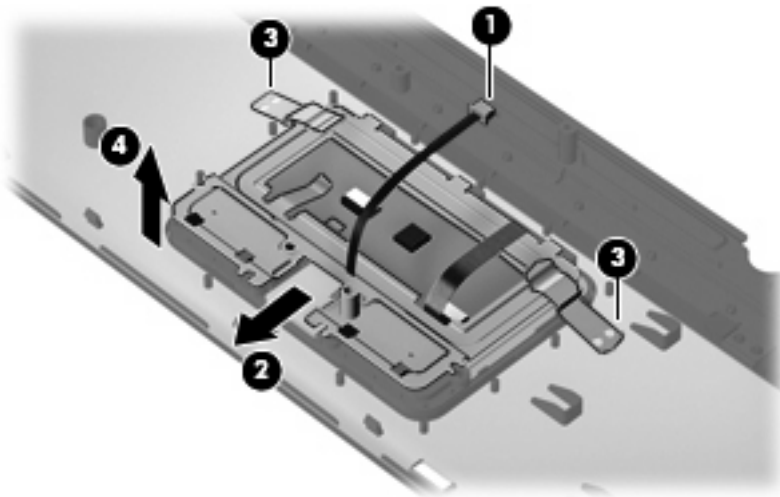

5. Release the TouchPad board (1) by sliding it forward until the board clears the spring clips (2) built into the top cover.

6. Remove the TouchPad board (3).

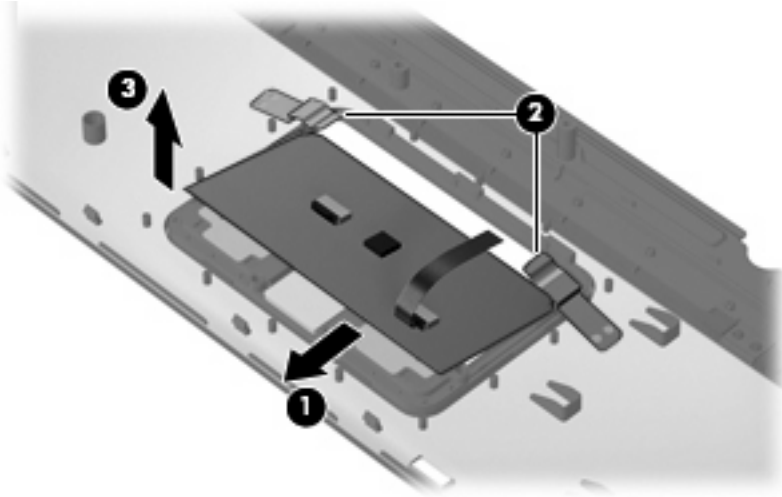

7. If it is necessary to replace the fingerprint reader board and cable, release the TouchPad button cable (1) to provide access to the fingerprint reader board.
8. Detach the fingerprint reader board (2) from the top cover. The fingerprint reader board is attached to the top cover with double-sided tape.

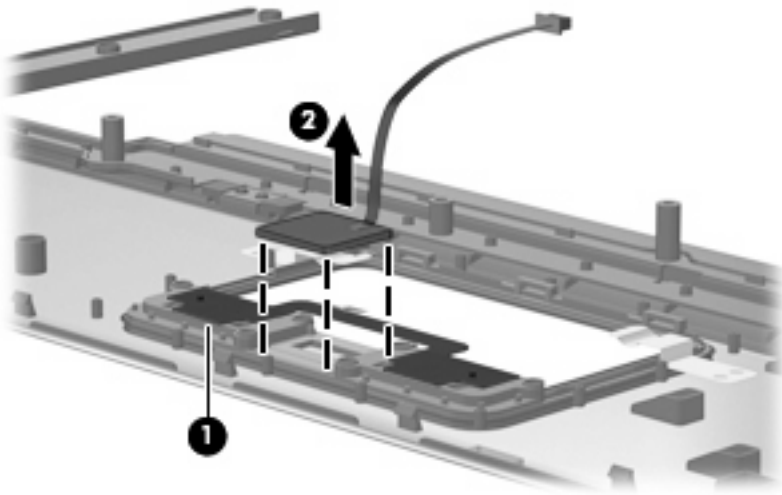

Reverse this procedure to install the TouchPad board.

ExpressCard board

Description	Spare part number
ExpressCard board (includes RTC battery)	486251-001

Before removing the ExpressCard board, follow these steps:

1. Shut down the computer. If you are unsure whether the computer is off or in Hibernation, turn the computer on, and then shut it down through the operating system.
2. Disconnect all external devices connected to the computer.
3. Disconnect the power from the computer by first unplugging the power cord from the AC outlet and then unplugging the AC adapter from the computer.
4. Remove the battery (see [Battery on page 46](#)).
5. Remove the following:
 - a. Hard drive (see [Hard drive on page 52](#))
 - b. Optical drive (see [Optical drive on page 55](#))
 - c. Keyboard (see [Keyboard on page 61](#))
 - d. Switch cover (see [Switch cover on page 65](#))
 - e. Display assembly (see [Display assembly on page 74](#))
 - f. Top cover (see [Top cover on page 81](#))

Remove the ExpressCard board:

1. Remove the two Phillips PM2.5×3.0 broad-head screws (1) that secure the ExpressCard board to the computer.
2. Remove the ExpressCard board (2).

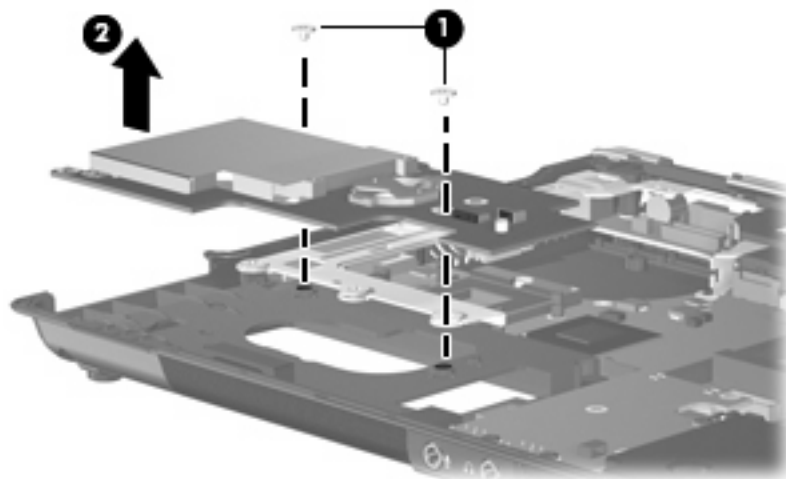

Reverse this procedure to install the ExpressCard board.

Audio board

Description	Spare part number
Audio board (includes cable)	486250-001

Before removing the audio board, follow these steps:

1. Shut down the computer. If you are unsure whether the computer is off or in Hibernation, turn the computer on, and then shut it down through the operating system.
2. Disconnect all external devices connected to the computer.
3. Disconnect the power from the computer by first unplugging the power cord from the AC outlet and then unplugging the AC Adapter from the computer.
4. Remove the battery (see [Battery on page 46](#)).
5. Remove the following:
 - a. Hard drive (see [Hard drive on page 52](#))
 - b. Optical drive (see [Optical drive on page 55](#))
 - c. Keyboard (see [Keyboard on page 61](#))
 - d. Switch cover (see [Switch cover on page 65](#))
 - e. Display assembly (see [Display assembly on page 74](#))
 - f. Top cover (see [Top cover on page 81](#))
 - g. ExpressCard board (see [ExpressCard board on page 86](#))

Remove the audio board:

1. Remove the three Phillips PM2.5×5.0 screws **(1)** that secure the audio board to the system board.
 **NOTE:** The audio board cable ground loop **(2)** is secured by the audio board rear screw.
2. Disconnect the speaker cable **(3)** from the audio board.

3. Disconnect the audio board cable (4) from the system board.

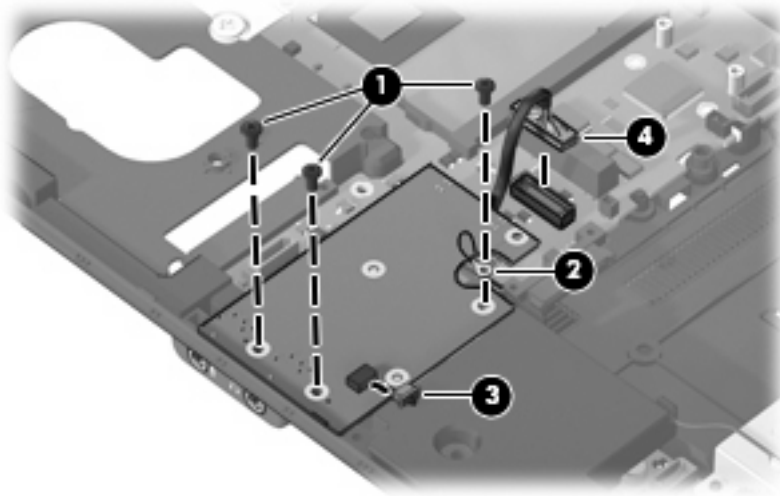

4. Release the audio board (1) by sliding it up and away from the front edge of the base enclosure.
5. Disconnect the microphone extension cable (2) from the audio board.
6. Disconnect the modem module cable (3) from the modem module.

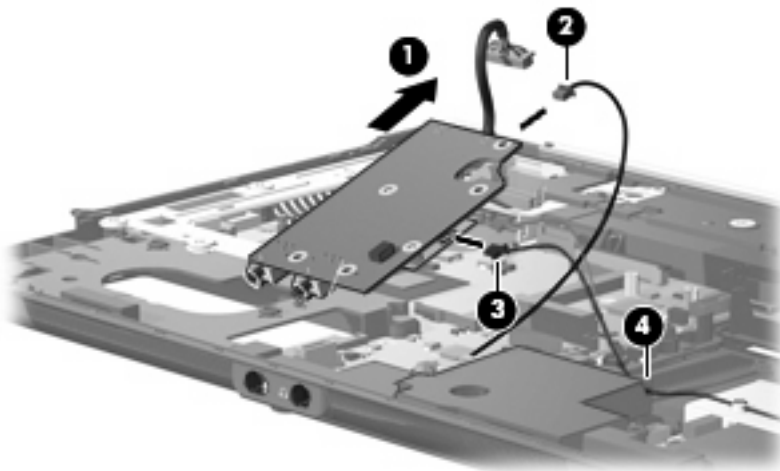

7. Remove the audio board.

Reverse this procedure to install the audio board.

Modem module

 **NOTE:** The modem module spare part kits do not include a modem module cable. The modem module cable is included in the Cable Kit, spare part number 486281-001.

Description	Spare part number
For use in all countries and regions except Australia and New Zealand	491575-001
For use only in Australia and New Zealand	491575-011

Before removing the modem module, follow these steps:

1. Shut down the computer. If you are unsure whether the computer is off or in Hibernation, turn the computer on, and then shut it down through the operating system.
2. Disconnect all external devices connected to the computer.
3. Disconnect the power from the computer by first unplugging the power cord from the AC outlet and then unplugging the AC adapter from the computer.
4. Remove the battery (see [Battery on page 46](#)).
5. Remove the following components:
 - a. Hard drive (see [Hard drive on page 52](#))
 - b. Optical drive (see [Optical drive on page 55](#))
 - c. Keyboard (see [Keyboard on page 61](#))
 - d. Switch cover (see [Switch cover on page 65](#))
 - e. Display assembly (see [Display assembly on page 74](#))
 - f. Top cover (see [Top cover on page 81](#))
 - g. ExpressCard board (see [ExpressCard board on page 86](#))
 - h. Audio board (see [Audio board on page 87](#))

Remove the modem module:

1. Turn the audio board upside down, with the audio connectors toward you.
2. Remove the two Phillips PM2.5×3.0 screws **(1)** that secure the modem module to the audio board.

 **NOTE:** The audio board cable ground loop **(2)** is secured by the modem module rear screw.

3. Lift the modem module (3) straight up to disconnect it from the audio board.

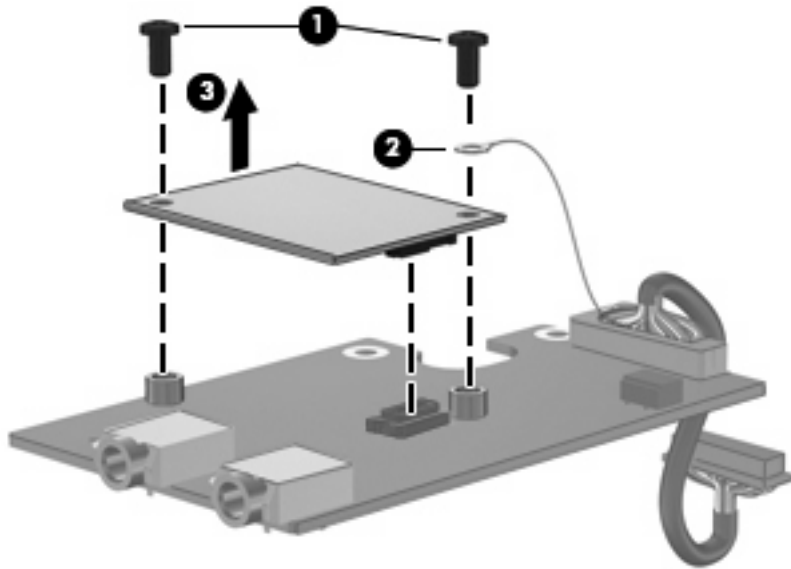

4. Remove the modem module.

Reverse this procedure to install the modem module.

Speaker

Description	Spare part number
Speaker	486280-001

Before removing the speaker, follow these steps:

1. Shut down the computer. If you are unsure whether the computer is off or in Hibernation, turn the computer on, and then shut it down through the operating system.
2. Disconnect all external devices connected to the computer.
3. Disconnect the power from the computer by first unplugging the power cord from the AC outlet and then unplugging the AC adapter from the computer.
4. Remove the battery (see [Battery on page 46](#)).
5. Remove the following:
 - a. Hard drive (see [Hard drive on page 52](#))
 - b. Optical drive (see [Optical drive on page 55](#))
 - c. Keyboard (see [Keyboard on page 61](#))
 - d. Switch cover (see [Switch cover on page 65](#))
 - e. Display assembly (see [Display assembly on page 74](#))
 - f. Top cover (see [Top cover on page 81](#))
 - g. ExpressCard board (see [ExpressCard board on page 86](#))
 - h. Audio board (see [Audio board on page 87](#))

Remove the speaker:

1. Remove the three Phillips PM2.0×5.0 screws **(1)** that secure the speaker to the base enclosure.

2. Remove the speaker (2) from the base enclosure.

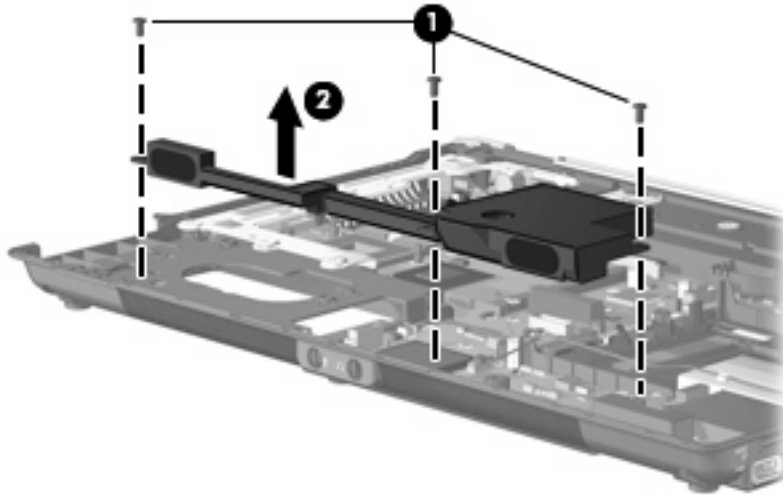

Reverse this procedure to install the speaker.

USB/digital media board

Description	Spare part number
USB/digital media board (includes cable)	486249-001

Before removing the USB/digital media board, follow these steps:

1. Shut down the computer. If you are unsure whether the computer is off or in Hibernation, turn the computer on, and then shut it down through the operating system.
2. Disconnect all external devices connected to the computer.
3. Disconnect the power from the computer by first unplugging the power cord from the AC outlet and then unplugging the AC Adapter from the computer.
4. Remove the battery (see [Battery on page 46](#)).
5. Remove the following:
 - a. Hard drive (see [Hard drive on page 52](#))
 - b. Optical drive (see [Optical drive on page 55](#))
 - c. Keyboard (see [Keyboard on page 61](#))
 - d. Switch cover (see [Switch cover on page 65](#))
 - e. Display assembly (see [Display assembly on page 74](#))
 - f. Top cover (see [Top cover on page 81](#))

Remove the USB/digital media board cable:

1. Disconnect the USB/digital media board cable (1) from the system board.
2. Remove the three Phillips PM2.5×5.0 screws (2) that secure the USB/digital media board to the base enclosure.
3. Remove the USB/digital media board (3).

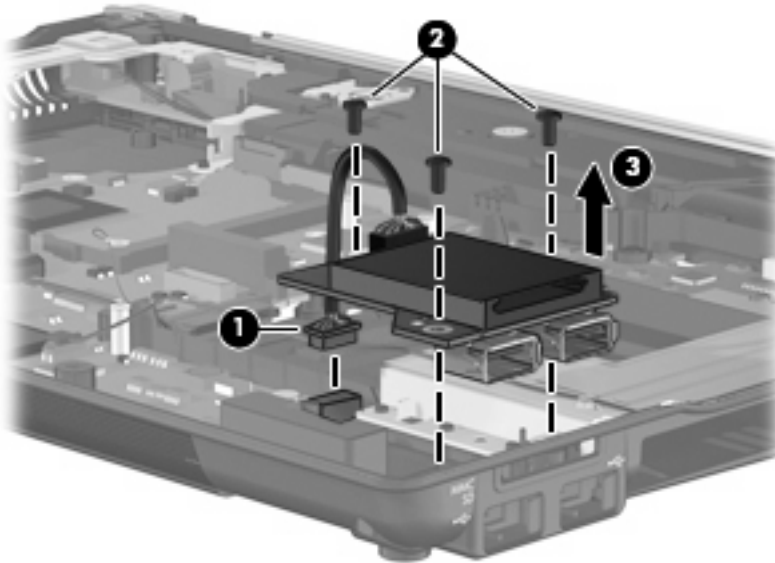

Reverse this procedure to install the USB/digital media board.

Rear cover

Description	Spare part number
Rear cover	486291-001

Before removing the rear cover, follow these steps:

1. Shut down the computer. If you are unsure whether the computer is off or in Hibernation, turn the computer on, and then shut it down through the operating system.
2. Disconnect all external devices connected to the computer.
3. Disconnect the power from the computer by first unplugging the power cord from the AC outlet and then unplugging the AC Adapter from the computer.
4. Remove the battery (see [Battery on page 46](#)).
5. Remove the following:
 - a. Hard drive (see [Hard drive on page 52](#))
 - b. Optical drive (see [Optical drive on page 55](#))
 - c. Keyboard (see [Keyboard on page 61](#))
 - d. Switch cover (see [Switch cover on page 65](#))

- e. Display assembly (see [Display assembly on page 74](#))
- f. Top cover (see [Top cover on page 81](#))

Remove the rear cover:

1. Turn the computer upside down, with the rear panel toward you.
2. Remove the three Torx8 T8M2.5×9.0 screws that secure the rear cover to the base enclosure.

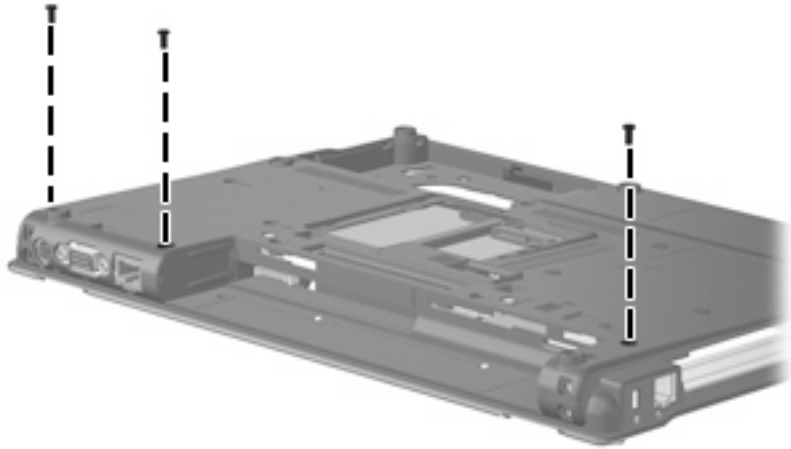

3. Turn the computer right side up, with the front toward you.
4. Remove the three Phillips PM2.5×3.0 broad-head screws (1) and the two Phillips PM2.5×5.0 screws (2) that secure the rear cover to the base enclosure.

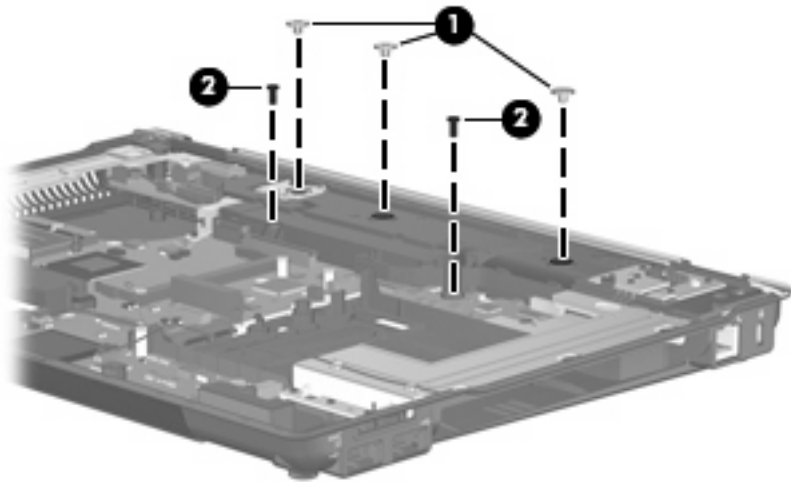

5. Lift the rear edge of the rear cover (1) until it disengages from the base enclosure.

6. Remove the rear cover (2) by lifting it straight up.

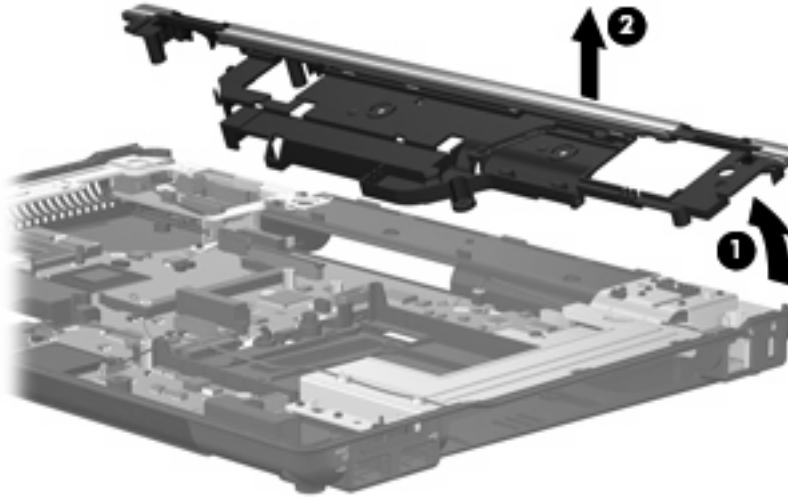

Reverse this procedure to install the rear cover.

SIM connector board

 **NOTE:** This section applies only to computer models equipped with a WWAN module.

Description	Spare part number
SIM connector board	486252-001

Before removing the SIM connector board, follow these steps:

1. Shut down the computer. If you are unsure whether the computer is off or in Hibernation, turn the computer on, and then shut it down through the operating system.
2. Disconnect all external devices connected to the computer.
3. Disconnect the power from the computer by first unplugging the power cord from the AC outlet and then unplugging the AC Adapter from the computer.
4. Remove the battery (see [Battery on page 46](#)).
5. Remove the following:
 - a. Hard drive (see [Hard drive on page 52](#))
 - b. Optical drive (see [Optical drive on page 55](#))
 - c. Keyboard (see [Keyboard on page 61](#))
 - d. Switch cover (see [Switch cover on page 65](#))
 - e. Display assembly (see [Display assembly on page 74](#))
 - f. Top cover (see [Top cover on page 81](#))
 - g. Rear cover (see [Rear cover on page 93](#))

Remove the SIM connector board:

1. Remove the two Phillips PM2.0×5.0 screws (1) that secure the SIM connector board to the base enclosure.
2. Remove the SIM connector board (2) by sliding it forward, and then lifting it out of the base enclosure.

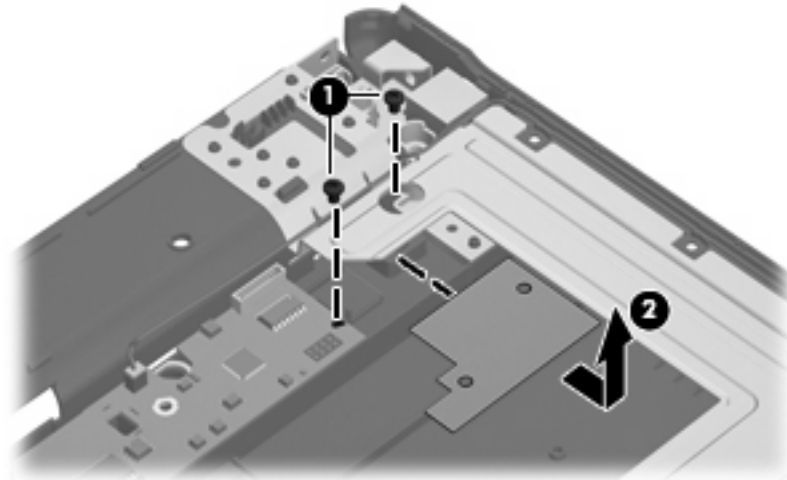

Reverse this procedure to install the SIM connector board.

Modem module cable

 **NOTE:** The modem module cable is included in the Cable Kit, spare part number 486281-001.

Before removing the modem module cable, follow these steps:

1. Shut down the computer. If you are unsure whether the computer is off or in Hibernation, turn the computer on, and then shut it down through the operating system.
2. Disconnect all external devices connected to the computer.
3. Disconnect the power from the computer by first unplugging the power cord from the AC outlet and then unplugging the AC Adapter from the computer.
4. Remove the battery (see [Battery on page 46](#)).
5. Remove the following:
 - a. Hard drive (see [Hard drive on page 52](#))
 - b. Optical drive (see [Optical drive on page 55](#))
 - c. Keyboard (see [Keyboard on page 61](#))
 - d. Switch cover (see [Switch cover on page 65](#))
 - e. Display assembly (see [Display assembly on page 74](#))
 - f. Top cover (see [Top cover on page 81](#))
 - g. Rear cover (see [Rear cover on page 93](#))

Remove the modem module cable:

1. Disconnect the modem module cable (1) from the system board.
2. Remove the modem module cable (2) from the clips built into the system board bracket.
3. Remove the RJ-11 connector (3) from the clip built into the base enclosure.

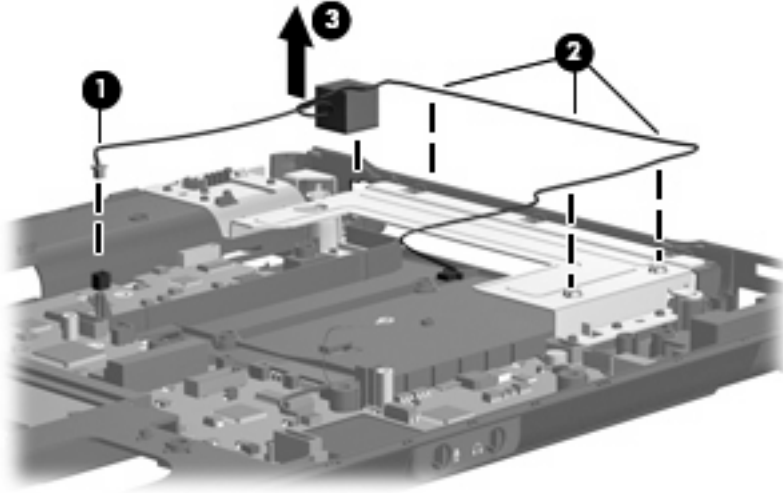

4. Remove the modem module cable.

Reverse this procedure to install the modem module cable.

Bluetooth module cable

 **NOTE:** The Bluetooth module cable is included in the Cable Kit, spare part number 486281-001.

Before removing the Bluetooth module cable, follow these steps:

1. Shut down the computer. If you are unsure whether the computer is off or in Hibernation, turn the computer on, and then shut it down through the operating system.
2. Disconnect all external devices connected to the computer.
3. Disconnect the power from the computer by first unplugging the power cord from the AC outlet and then unplugging the AC Adapter from the computer.
4. Remove the battery (see [Battery on page 46](#)).
5. Remove the following:
 - a. Hard drive (see [Hard drive on page 52](#))
 - b. Optical drive (see [Optical drive on page 55](#))
 - c. Keyboard (see [Keyboard on page 61](#))
 - d. Switch cover (see [Switch cover on page 65](#))
 - e. Display assembly (see [Display assembly on page 74](#))

- f. Top cover (see [Top cover on page 81](#))
- g. Rear cover (see [Rear cover on page 93](#))

Remove the Bluetooth module cable:

1. Disconnect the Bluetooth module cable (1) from the system board.
2. Remove the Bluetooth module cable (2) from the opening built into the base enclosure.

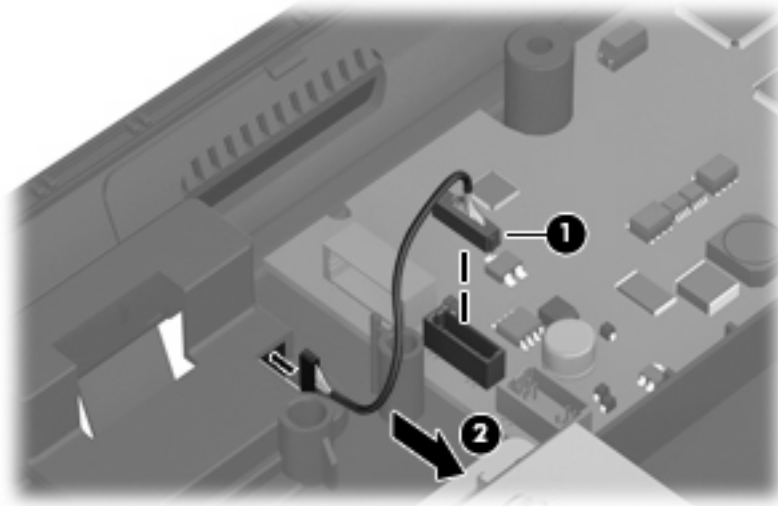

3. Remove the Bluetooth module cable.

Reverse this procedure to install the Bluetooth module cable.

System board

 **NOTE:** All system board spare part kits include replacement thermal material.

Description	Spare part number
For use only with HP Compaq 6535b computer models equipped with both WLAN and WWAN modules	488193-001
For use only with HP Compaq 6535b computer models equipped with a WLAN module but not a WWAN module	488194-001
For use only with HP Compaq 6530b computer models equipped with both WLAN and WWAN modules	486247-001
For use only with HP Compaq 6530b computer models equipped with a WLAN module but not a WWAN module	486248-001

Before removing the system board, follow these steps:

1. Shut down the computer. If you are unsure whether the computer is off or in Hibernation, turn the computer on, and then shut it down through the operating system.
2. Disconnect all external devices connected to the computer.
3. Disconnect the power from the computer by first unplugging the power cord from the AC outlet and then unplugging the AC Adapter from the computer.
4. Remove the battery (see [Battery on page 46](#)).
5. Remove the following:
 - a. Hard drive (see [Hard drive on page 52](#))
 - b. Optical drive (see [Optical drive on page 55](#))
 - c. Keyboard (see [Keyboard on page 61](#))
 - d. Switch cover (see [Switch cover on page 65](#))
 - e. Fan (see [Fan on page 66](#))
 - f. Heat sink (see [Heat sink on page 68](#))
 - g. Display assembly (see [Display assembly on page 74](#))
 - h. Top cover (see [Top cover on page 81](#))
 - i. ExpressCard board (see [ExpressCard board on page 86](#))
 - j. Audio board (see [Audio board on page 87](#))
 - k. Speaker (see [Speaker on page 91](#))
 - l. Rear cover (see [Rear cover on page 93](#))
 - m. SIM connector board (see [SIM connector board on page 95](#))

When replacing the system board, be sure that the following components are removed from the defective system board and installed on the replacement system board:

- RTC battery (see [RTC battery on page 54](#))
- WLAN module (see [WLAN module on page 57](#))
- Memory modules (see [Expansion memory module on page 59](#) and [Primary memory module on page 63](#))
- WWAN module (see [WWAN module on page 64](#))
- Processor (see [Processor on page 72](#))

Remove the system board:

1. Position the computer with rear panel toward you.
2. Remove the four Phillips PM2.0×3.0 broad-head screws **(1)** and the two hex HM5.0×9.0 screw locks **(2)** that secure the system board bracket to the base enclosure.
3. Remove the system board bracket **(3)**.

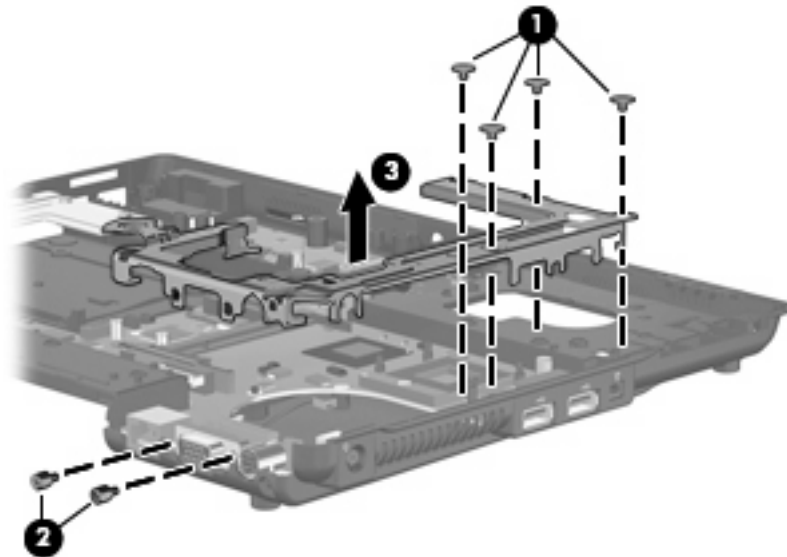

4. Position the computer with the front toward you.
5. Disconnect the Bluetooth module cable **(1)** and the modem module cable **(2)** from the system board.

 **NOTE:** Step 6 applies only to computer models not equipped with WWAN capability.

6. Remove the Phillips PM2.0×5.0 screw (3) that secures the system board to the base enclosure.

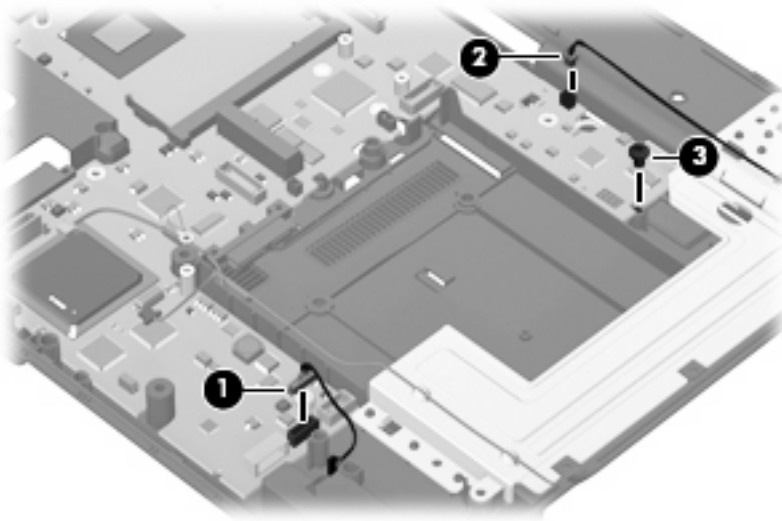

7. Use the optical drive connector (1) to lift the right side of the system board (2) until it rests at an angle.
8. Remove the system board (3) from the base enclosure by sliding it up and to the right.

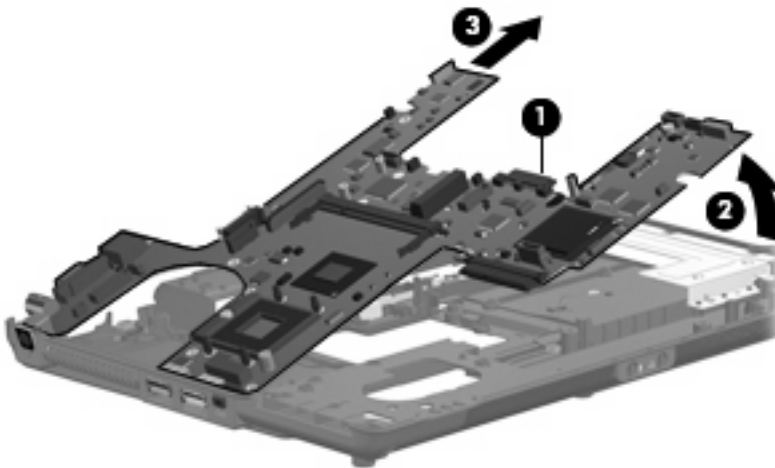

Reverse the preceding procedure to install the system board.

Microphone extension cable

 **NOTE:** The microphone extension cable is included in the Cable Kit, spare part number 486281-001.

Before removing the microphone extension cable, follow these steps:

1. Shut down the computer. If you are unsure whether the computer is off or in Hibernation, turn the computer on, and then shut it down through the operating system.
2. Disconnect all external devices connected to the computer.
3. Disconnect the power from the computer by first unplugging the power cord from the AC outlet and then unplugging the AC Adapter from the computer.
4. Remove the battery (see [Battery on page 46](#)).
5. Remove the following:
 - a. Hard drive (see [Hard drive on page 52](#))
 - b. Optical drive (see [Optical drive on page 55](#))
 - c. Keyboard (see [Keyboard on page 61](#))
 - d. Switch cover (see [Switch cover on page 65](#))
 - e. Display assembly (see [Display assembly on page 74](#))
 - f. Top cover (see [Top cover on page 81](#))
 - g. Rear cover (see [Rear cover on page 93](#))
 - h. SIM connector board (see [SIM connector board on page 95](#))
 - i. System board (see [System board on page 99](#))

Remove the microphone extension cable:

- Remove the microphone extension cable (1) from the clips (2) built into the base enclosure.

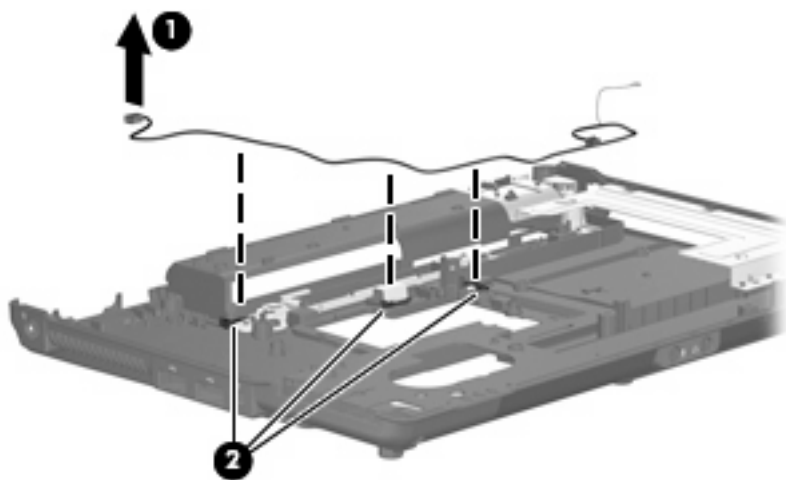

Reverse this procedure to install the microphone extension cable.

5 Computer Setup

This user guide describes features that are common to most models. Some features may not be available on your computer.

Starting Computer Setup

Computer Setup is a preinstalled, ROM-based utility that can be used even when the operating system is not working or will not load.

 **NOTE:** Some of the Computer Setup menu items listed in this guide may not be supported by your computer.

NOTE: An external keyboard or mouse connected to a USB port can be used with Computer Setup only if USB legacy support is enabled.

To start Computer Setup, follow these steps:

1. Turn on or restart the computer, and then press **esc** while the “Press the ESC key for Startup Menu” message is displayed at the bottom of the screen.
2. Press **f10** to enter BIOS Setup.

Using Computer Setup

Navigating and selecting in Computer Setup

The information and settings in Computer Setup are accessed from the File, Security, Diagnostics, and System Configuration menus.

To navigate and select in Computer Setup, follow these steps:

1. Turn on or restart the computer, and then press **esc** while the “Press the ESC key for Startup Menu” message is displayed at the bottom of the screen.

 **NOTE:** You can use either a pointing device (TouchPad, pointing stick, or USB mouse) or the keyboard to navigate and make selections in Computer Setup.

- To select a menu or a menu item, use the keyboard arrow keys and then press **enter**, or use a pointing device to click the item.
 - To scroll up and down, click the plus sign (+) or the minus sign (-) in the upper-right corner of the screen.
 - To close open dialog boxes and return to the main Computer Setup screen, press **esc**, and then follow the on-screen instructions.
2. Press **f10** to enter BIOS Setup.
 3. Select the **File**, **Security**, **Diagnostics**, or **System Configuration** menu.

To exit Computer Setup menus, choose one of the following methods:

- To exit Computer Setup menus without saving your changes, click **Exit** in the lower-left corner of the screen, and then follow the on-screen instructions.
– or –
Use the arrow keys to select **File > Ignore changes and exit**, and then press **enter**.
– or –
- To save your changes and exit Computer Setup menus, click **Save** in the lower-left corner of the screen, and then follow the on-screen instructions.
– or –
Use the arrow keys to select **File > Save changes and exit**, and then press **enter**.

Your changes go into effect when the computer restarts.

Restoring factory settings in Computer Setup

 **NOTE:** Restoring defaults will not change the hard drive mode.

To return all settings in Computer Setup to the values that were set at the factory, follow these steps:

1. Turn on or restart the computer, and then press **esc** while the “Press the ESC key for Startup Menu” message is displayed at the bottom of the screen.
2. Press **f10** to enter BIOS Setup.
3. Use a pointing device or the arrow keys to select **File > Restore defaults**.
4. Follow the on-screen instructions.
5. To save your changes and exit, click **Save** in the lower-left corner of the screen, and then follow the on-screen instructions.

– or –

Use the arrow keys to select **File > Save changes and exit**, and then press **enter**.

Your changes go into effect when the computer restarts.

 **NOTE:** Your password settings and security settings are not changed when you restore the factory settings.

Computer Setup Menus

The menu tables in this section provide an overview of Computer Setup options.

 **NOTE:** Some of the Computer Setup menu items listed in this chapter may not be supported by your computer.

File menu

Select	To do this
System Information	<ul style="list-style-type: none">• View identification information for the computer and the batteries in the system.• View specification information for the processor, cache and memory size, system ROM, video revision, and keyboard controller version.
Set System Date and Time	Set or change the date and time on the computer.
Restore defaults	Replace the configuration settings in Computer Setup with the original factory settings. (Hard drive mode, password settings, and security settings are not changed when you restore the factory settings.)
Ignore changes and exit	Cancel any changes entered during the current session. Then exit and restart the computer.
Save changes and exit	Save changes and exit Save any changes entered during the current session. Then exit and restart the computer. Your changes go into effect when the computer restarts.

Security menu

 **NOTE:** Some of the menu items listed in this section may not be supported by your computer.

Select	To do this
User Management (requires an administrator password)	<ul style="list-style-type: none">• Create a new BIOS user account.• View a list of ProtectTools users.
Password Policy (requires an administrator password)	Revise password policy criteria.
Allow HP SpareKey Enrollment	Enable/disable permission to enroll or reset HP SpareKey.
HP SpareKey	Enable/disable HP SpareKey (enabled by default).
Fingerprint Reset on Reboot (if Present)	Enable/disable the fingerprint reader (select models only; disabled by default).
Change Password	Enter, change, or delete a BIOS administrator password.
DriveLock Passwords	<ul style="list-style-type: none">• Enable/disable DriveLock on any computer hard drive (enabled by default).• Change a DriveLock user password or master password. <p>NOTE: DriveLock settings are accessible only when you enter Computer Setup by turning on (not restarting) the computer.</p>
Automatic DriveLock	Enable/disable Automatic DriveLock support.

Select	To do this
TPM Embedded Security (requires an administrator password)	<ul style="list-style-type: none"> • Change TPM (Trusted Platform Module) Embedded Security device state at restart. The following options are available: <ul style="list-style-type: none"> ◦ Do Nothing (enabled by default) ◦ Available and Disabled ◦ Available and Enabled ◦ Factory Defaults • Reset Authentication Credential. • Enable/disable support for the following: <ul style="list-style-type: none"> ◦ Power-on authentication support (enabled by default) ◦ Operating system TPM management (enabled by default) ◦ Reset of TPM from operating system (disabled by default)
Disk Sanitizer	<p>Run Disk Sanitizer to destroy all existing data on the primary hard drive.</p> <p>CAUTION: If you run Disk Sanitizer, the data on the primary hard drive is destroyed permanently.</p>
System IDs	Enter a user-defined computer asset tracking number and ownership tag.

Diagnostics menu

Select	To do this
System Diagnostics menu	<ul style="list-style-type: none"> • F1 System Information—Displays the following information: <ul style="list-style-type: none"> ◦ Identification information for the computer and the batteries in the system. ◦ Specification information for the processor, cache and memory size, system ROM, video revision, and keyboard controller version. • F2 Start-up Test—Verifies the system components needed for starting the computer. • F3 Run-In Test—Runs a comprehensive check on system memory. • F4 Hard Disk Test—Runs a comprehensive self-test on any hard drive in the system.

System Configuration menu

 **NOTE:** Some of the listed System Configuration options may not be supported by your computer.

Select	To do this
Language	Change the Computer Setup language.
Boot Options	<ul style="list-style-type: none"> • Set a Startup Menu delay (in seconds). • Enable/disable Custom Logo (disabled by default). • Enable/disable Display Diagnostic URL (disabled by default).

Select	To do this
	<ul style="list-style-type: none"> • Enable/disable CD-ROM boot (enabled by default). • Enable/disable SD Card boot (enabled by default). • Enable/disable diskette boot (enabled by default). • Enable/disable boot from Extensible Firmware Interface (EFI) File (select models only; enabled by default). • Enable/disable internal network adapter boot and set the Preboot eXecution Environment (PXE) (enabled by default). • Set the Express Boot Popup delay in seconds. • Set the boot order.
Device Configurations	<ul style="list-style-type: none"> • Enable/Disable Unified Extensible Firmware Interface (UEFI) mode (disabled by default). • Enable/disable USB legacy support (enabled by default). When enabled, USB legacy support allows the following: <ul style="list-style-type: none"> ◦ Use of a USB keyboard in Computer Setup even when a Windows® operating system is not running. ◦ Startup from bootable USB devices, including a hard drive, diskette drive, or optical drive connected by a USB port to the computer. • Select a parallel port mode: ECP (Enhanced Capabilities Port), standard, bidirectional, or EPP (Enhanced Parallel Port). • Enable/disable BIOS DMA data transfers (select models only; enabled by default). • Enable/disable fan always on while connected to an AC outlet (disabled by default). • Enable/disable LAN Power Save. When enabled, saves power by turning off the LAN when not in use (enabled by default). • Enable/disable Data Execution Prevention. When enabled, the processor can disable some virus code execution, which helps to improve computer security. • SATA (Serial Advanced Technology Attachment) device mode. The following options are available: <ul style="list-style-type: none"> ◦ AHCI (Advanced Host Controller Interface) ◦ IDE (Integrated Drive Electronics) <p>NOTE: Availability of the options above varies by computer model.</p> • Enable/disable secondary battery fast charge (enabled by default). • Enable/disable HP QuickLook 2 (enabled by default). • Enable/disable Virtualization Technology (select models only; enabled by default). • Enable/disable TXT (Intel® Trusted Execution Technology) (select models only; enabled by default). • Enable/disable Dual Core CPU (select models only; enabled by default).
Built-In Device Options	<ul style="list-style-type: none"> • Enable/disable the wireless button state (enabled by default). • Enable/disable embedded WWAN device radio (select models only; enabled by default).

Select	To do this
	<ul style="list-style-type: none"> • Enable/disable embedded Bluetooth® device radio (enabled by default). • Enable/disable the Network Interface Controller (LAN) (enabled by default). • Set the wake on LAN state. Options include the following: <ul style="list-style-type: none"> ◦ Disabled ◦ Boot to Network (set by default) ◦ Follow Boot Order • Enable/disable the fingerprint device (enabled by default). • Enable/disable a modem device (enabled by default).
Port Options (all are enabled by default)	<p>NOTE: All port options are enabled by default.</p> <ul style="list-style-type: none"> • Enable/disable the smart card slot. • Enable/disable the ExpressCard slot. • Enable/disable the serial port. • Enable/disable the parallel port. • Enable/disable the flash media reader. • Enable/disable the USB port. <p>CAUTION: Disabling the USB port also disables MultiBay devices and ExpressCard devices on the advanced port replicator.</p> <ul style="list-style-type: none"> • Enable/disable the 1394 port.
Set Security Level	Change, view, or hide security levels for all BIOS menu items.
Restore Security Defaults	Restore the default security settings.

6 Specifications

Computer specifications

	Metric	U.S.
Dimensions		
Depth	24.28 cm	9.56 in
Width	33.48 cm	13.18 in
Height	3.26 cm	1.28 in
Weight (equipped with optical drive, hard drive, and battery)	2.41 kg	5.31 lbs
Input power		
Operating voltage	18.5 V dc @ 3.5 A - 65 W or 19.0 V dc @ 4.74 A - 90 W	
Operating current	3.5 A or 4.74 A	
Temperature		
Operating (not writing to optical disc)	0°C to 35°C	32°F to 95°F
Operating (writing to optical disc)	5°C to 35°C	41°F to 95°F
Nonoperating	-20°C to 60°C	-4°F to 140°F
Relative humidity (noncondensing)		
Operating	10% to 90%	
Nonoperating	5% to 95%	
Maximum altitude (unpressurized)		
Operating	-15 m to 3,048 m	-50 ft to 10,000 ft
Nonoperating	-15 m to 12,192 m	-50 ft to 40,000 ft
Shock		
Operating	125 g, 2 ms, half-sine	
Nonoperating	200 g, 2 ms, half-sine	
Random vibration		
Operating	0.75 g zero-to-peak, 10 Hz to 500 Hz, 0.25 oct/min sweep rate	

	Metric	U.S.
Nonoperating	1.50 g zero-to-peak, 10 Hz to 500 Hz, 0.5 oct/min sweep rate	

NOTE: Applicable product safety standards specify thermal limits for plastic surfaces. The computer operates well within this range of temperatures.

14.1-inch, WXGA display specifications

	Metric	U.S.
Dimensions		
Height	27.94 cm	11.0 in
Width	20.83 cm	8.2 in
Diagonal	35.56 cm	14.1 in
Number of colors	Up to 16.8 million	
Contrast ratio	250:1 (typical)	
Brightness	180 nits (typical)	
Pixel resolution		
Pitch	0.279 × 0.279 mm	
Format	1280 × 800	
Configuration	RGB vertical stripe	
Backlight	Edge lit	
Character display	80 × 25	
Total power consumption	4.0 W	
Viewing angle	+/-40 horizontal, +20/-40° vertical (typical)	

Hard drive specifications

	250-GB*	160-GB*	120-GB*
Dimensions			
Height	9.5 mm	9.5 mm	9.5 mm
Width	70 mm	70 mm	70 mm
Weight	101 g	101 g	101 g
Interface type			
	SATA	SATA	SATA
Transfer rate			
	100 MB/sec	100 MB/sec	100 MB/sec
Security			
	ATA security	ATA security	ATA security
Seek times (typical read, including setting)			
Single track	3 ms	3 ms	3 ms
Average	13 ms	13 ms	13 ms
Maximum	24 ms	24 ms	24 ms
Logical blocks			
	488,376,280	312,560,640	234,420,480
Disc rotational speed			
	5400 rpm	5400 rpm	7200 rpm and 5400 rpm
Operating temperature			
	5°C to 55°C (41°F to 131°F)		
*1 GB = 1 billion bytes when referring to hard drive storage capacity. Actual accessible capacity is less. Actual drive specifications may differ slightly.			
NOTE: Certain restrictions and exclusions apply. Contact technical support for details.			

DVD±RW and CD-RW Double-Layer Combo Drive specifications

Applicable disc	Read:	Write:
	CD-DA, CD+(E)G, CD-MIDI, CD-TEXT, CD-ROM, CD-ROM XA, MIXED MODE CD, CD-I, CD-I Bridge (Photo-CD, Video CD), Multisession CD (Photo-CD, CD-EXTRA, Portfolio, CD-R, CD-RW), CD-R, CD-RW, DVD-ROM (DVD-5, DVD-9, DVD-10, DVD-18), DVD-R, DVD-RW, DVD+R, DVD+RW, DVD-RAM	CD-R and CD-RW DVD+R, DVD+RW, DVD-R, DVD-RW, DVD-RAM
Access time	CD	DVD
Random	< 175 ms	< 230 ms
Cache buffer	2 MB	
Data transfer rate		
24X CD-ROM	3,600 KB/sec	
8X DVD-ROM	10,800 KB/sec	
24X CD-R	3,600 KB/sec	
16X CD-RW	2,400 KB/sec	
8X DVD+R	10,800 KB/sec	
4X DVD+RW	5,400 KB/sec	
8X DVD-R	10,800 KB/sec	
4X DVD-RW	5,400 KB/sec	
2.4X DVD+R(9)	2,700 KB/sec	
5X DVD-RAM	6,750 KB/sec	

DVD/CD-RW Combo Drive specifications

Applicable disc	Read:	Write:
	CD-DA, CD+(E)G, CD-MIDI, CD-TEXT, CD-ROM, CD-ROM XA, MIXED MODE CD, CD-I, CD-I Bridge (Photo-CD, Video CD), Multisession CD (Photo-CD, CD-EXTRA, Portfolio, CD-R, CD-RW), CD-R, CD-RW, DVD-ROM (DVD-5, DVD-9, DVD-10, DVD-18), DVD-R, DVD-RW, DVD+R, DVD+RW, DVD-RAM	CD-R and CD-RW
Access time	CD	DVD
Random	< 110 ms	< 130 ms
Cache buffer	2 MB	
Data transfer rate		
24X CD-ROM	3,600 KB/sec	
8X DVD	3,600 KB/sec	
24X CD-R	3,600 KB/sec	
24X CD-RW	3,600 KB/sec	

DVD-ROM Drive

Applicable disc	DVD-ROM (DVD-5, DVD-9, DVD-10, DVD-18, CD-ROM (Mode 1 and 2), CD Digital Audio, CD-XA ready (Mode 2, Form 1 and Form 2), CD-I (Mode 2, Form 1 and Form 2), CD-R, CD-RW, Photo CD (single and multisession), CD-Bridge)	
Access time	CD	DVD
Random	< 100 ms	< 125 ms
Cache buffer	512 KB	
Data transfer rate		
CD-R (24X)	3600 KB/s (150 KB/s at 1X CD rate)	
CD-RW (10X)	1500 KB/s (150 KB/s at 1X CD rate)	
CD-ROM (24X)	3600 KB/s (150 KB/s at 1X CD rate)	
DVD (8X)	10,800 KB/s (1,352 KB/s at 1X DVD rate)	
Multiword DMA mode 2	16.6 MB/s	

System DMA specifications

Hardware DMA	System function
DMA0	Not applicable
DMA1*	Not applicable
DMA2*	Not applicable
DMA3	Not applicable
DMA4	Direct memory access controller
DMA5*	Available for PC Card
DMA6	Not assigned
DMA7	Not assigned

*PC Card controller can use DMA 1, 2, or 5.

System interrupt specifications

Hardware IRQ	System function
IRQ0	System timer
IRQ1	Standard 101-/102-Key or Microsoft® Natural Keyboard
IRQ2	Cascaded
IRQ3	Intel 82801DB/DBM USB2 Enhanced Host Controller—24CD
IRQ4	COM1
IRQ5*	Conexant AC—Link Audio Intel 82801DB/DBM SMBus Controller—24C3 Data Fax Modem with SmartCP
IRQ6	Diskette drive
IRQ7*	Parallel port
IRQ8	System CMOS/real-time clock
IRQ9*	Microsoft ACPI-compliant system
IRQ10*	Intel USB UHCI controller—24C2 Intel 82852/82855 GM/GME Graphic Controller Realtek RTL8139 Family PCI Fast Ethernet Controller
IRQ11	Intel USB EHCI controller—24CD Intel USB UHCI controller—24C4 Intel USB UHCI controller—24C7 Intel Pro/Wireless 2200BG TI OHCI 1394 host controller TI PCI1410 CardBus controller
IRQ12	Synaptics PS/2 TouchPad
IRQ13	Numeric data processor
IRQ14	Primary IDE channel
IRQ15	Secondary IDE channel

*Default configuration; audio possible configurations are IRQ5, IRQ7, IRQ9, IRQ10, or none.

NOTE: PC Cards may assert IRQ3, IRQ4, IRQ5, IRQ7, IRQ9, IRQ10, IRQ11, or IRQ15. Either the infrared or the serial port may assert IRQ3 or IRQ4.

System I/O address specifications

I/O address (hex)	System function (shipping configuration)
000 - 00F	DMA controller no. 1
010 - 01F	Unused
020 - 021	Interrupt controller no. 1
022 - 024	Opti chipset configuration registers
025 - 03F	Unused
02E - 02F	87334 "Super I/O" configuration for CPU
040 - 05F	Counter/timer registers
044 - 05F	Unused
060	Keyboard controller
061	Port B
062 - 063	Unused
064	Keyboard controller
065 - 06F	Unused
070 - 071	NMI enable/RTC
072 - 07F	Unused
080 - 08F	DMA page registers
090 - 091	Unused
092	Port A
093 - 09F	Unused
0A0 - 0A1	Interrupt controller no. 2
I/O Address (hex)	System Function (shipping configuration)
0A2 - 0BF	Unused
0C0 - 0DF	DMA controller no. 2
0E0 - 0EF	Unused
0F0 - 0F1	Coprocessor busy clear/reset
0F2 - 0FF	Unused
100 - 16F	Unused
170 - 177	Secondary fixed disk controller
178 - 1EF	Unused
1F0 - 1F7	Primary fixed disk controller
1F8 - 200	Unused
201	JoyStick (decoded in ESS1688)
202 - 21F	Unused

I/O address (hex)	System function (shipping configuration)
220 - 22F	Entertainment audio
230 - 26D	Unused
26E - 26	Unused
278 - 27F	Unused
280 - 2AB	Unused
2A0 - 2A7	Unused
2A8 - 2E7	Unused
2E8 - 2EF	Reserved serial port
2F0 - 2F7	Unused
2F8 - 2FF	Infrared port
300 - 31F	Unused
320 - 36F	Unused
370 - 377	Secondary diskette drive controller
378 - 37F	Parallel port (LPT1/default)
380 - 387	Unused
388 - 38B	FM synthesizer—OPL3
38C - 3AF	Unused
3B0 - 3BB	VGA
3BC - 3BF	Reserved (parallel port/no EPP support)
3C0 - 3DF	VGA
3E0 - 3E1	PC Card controller in CPU
3E2 - 3E3	Unused
3E8 - 3EF	Internal modem
3F0 - 3F7	"A" diskette controller
3F8 - 3FF	Serial port (COM1/default)
CF8 - CFB	PCI configuration index register (PCIDIVO-1)
CFC - CFF	PCI configuration data register (PCIDIVO-1)

System memory map specifications

Size	Memory address	System function
640 KB	00000000-0009FFFF	Base memory
128 KB	000A0000-000BFFFF	Video memory
48 KB	000C0000-000CBFFF	Video BIOS
160 KB	000C8000-000E7FFF	Unused
64 KB	000E8000-000FFFFFF	System BIOS
15 MB	00100000-00FFFFFF	Extended memory
58 MB	04800000-07FFFFFF	Super extended memory
58 MB	04800000-07FFFFFF	Unused
2 MB	08000000-080FFFFFF	Video memory (direct access)
4 GB	08200000-FFFFFF	Unused
64 KB	FFFF0000-FFFFFFFF	System BIOS

7 Screw listing

This section provides specification and reference information for the screws and screw locks used in the computer. All screws listed in this section are available in the Screw Kit, spare part number 486294-001, and the Display Screw Kit, spare part number 486774-001.

Phillips PM2.0×5.0 captive screw

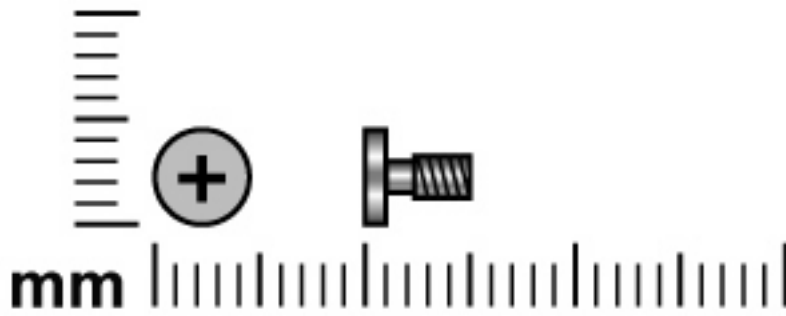

Color	Quantity	Length	Thread	Head diameter
Black	4	5.0 mm	2.0 mm	5.0 mm

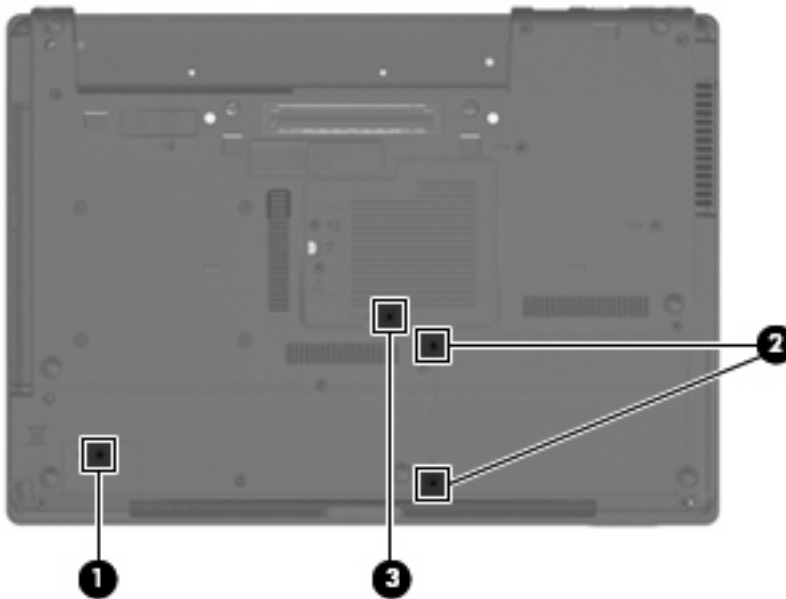

Where used:

- (1) One captive screw that secures the Bluetooth module compartment cover to the computer (screw is secured by a C-clip)
- (2) Two captive screws that secure the hard drive bay cover to the computer (screws are secured by C-clips)
- (3) One captive screw that secures the memory/WLAN module compartment cover to the computer (screw is secured by a C-clip)

Phillips PM2.5×10.0 captive screw

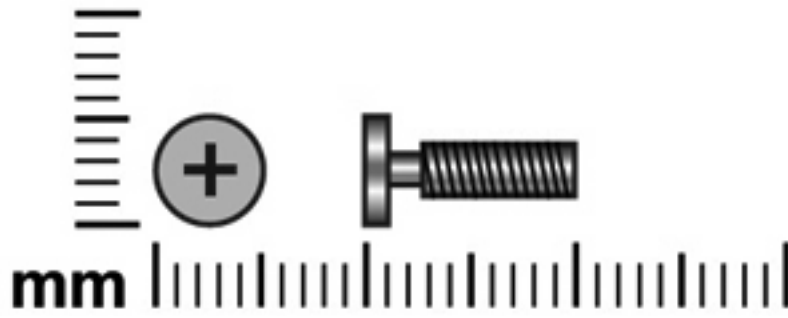

Color	Quantity	Length	Thread	Head diameter
Silver	1	10.0 mm	2.5 mm	5.0 mm

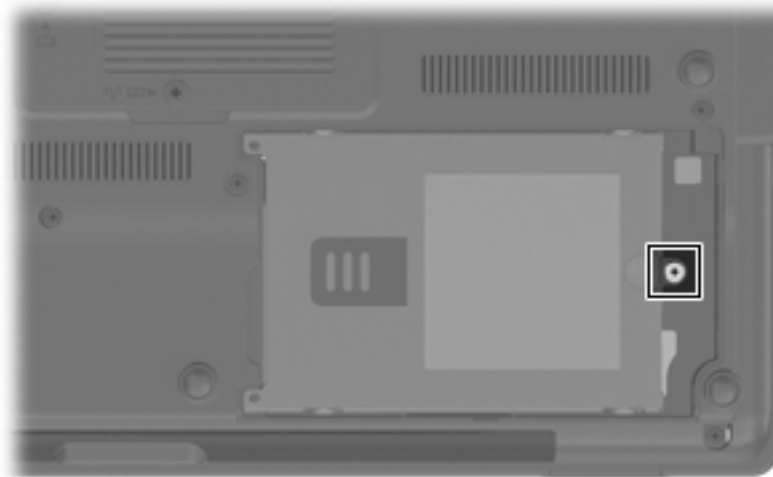

Phillips PM3.0×4.0 screw

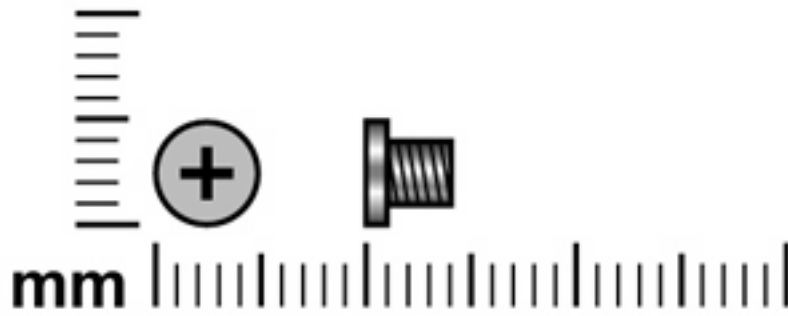

Color	Quantity	Length	Thread	Head diameter
Silver	4	4.0 mm	3.0 mm	5.0 mm

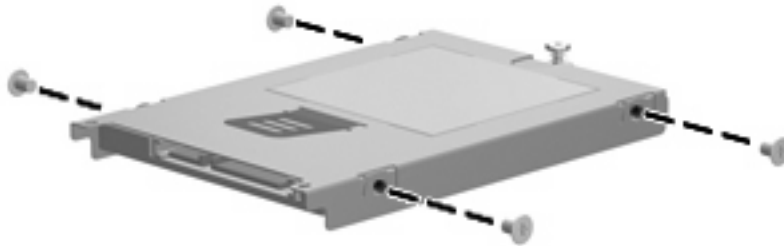

Where used: 4 screws that secure the hard drive bracket to the hard drive

Phillips PM2.5×9.0 captive screw

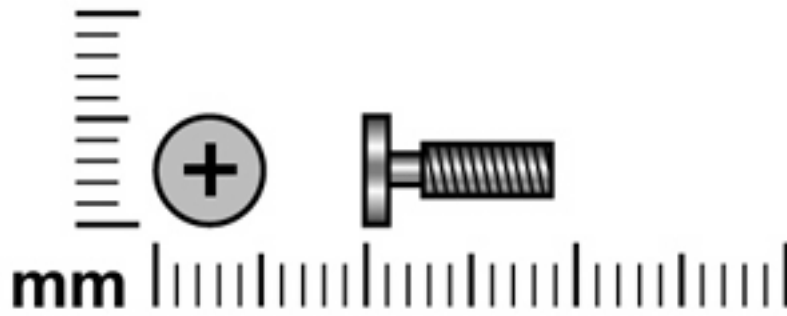

Color	Quantity	Length	Thread	Head diameter
Black	4	9.0 mm	2.5 mm	5.0 mm

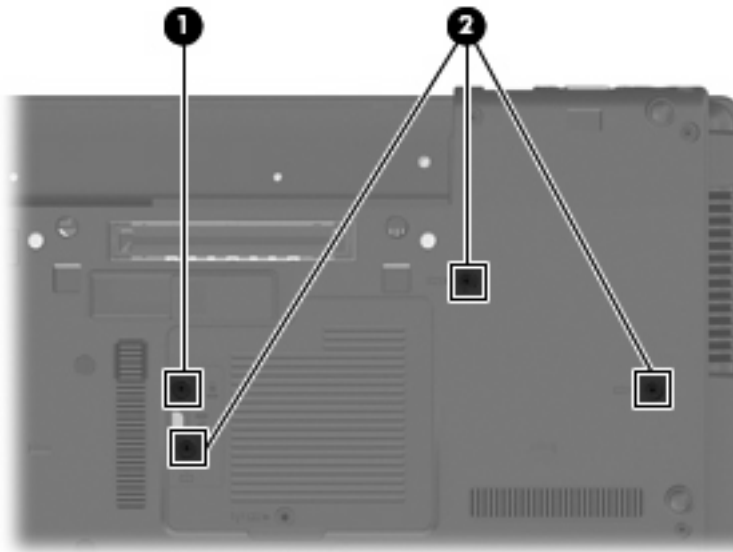

Where used:

- (1) One captive screw that secures the optical drive to the computer (screw is secured by a C-clip)
- (2) Three captive screws that secure the keyboard to the computer (screws are secured by C-clips)

Phillips PM2.0×3.0 screw

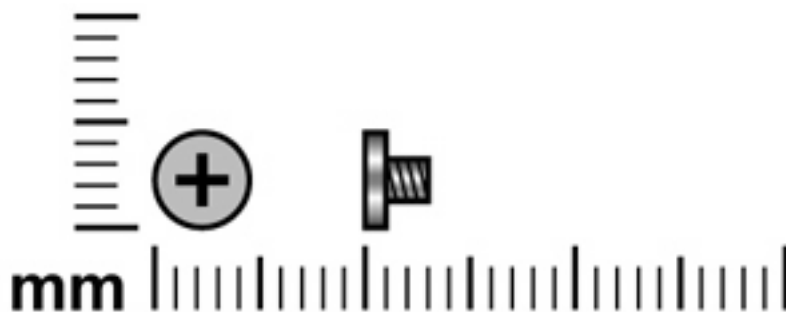

Color	Quantity	Length	Thread	Head diameter
Silver	19	3.0 mm	2.0 mm	4.5 mm

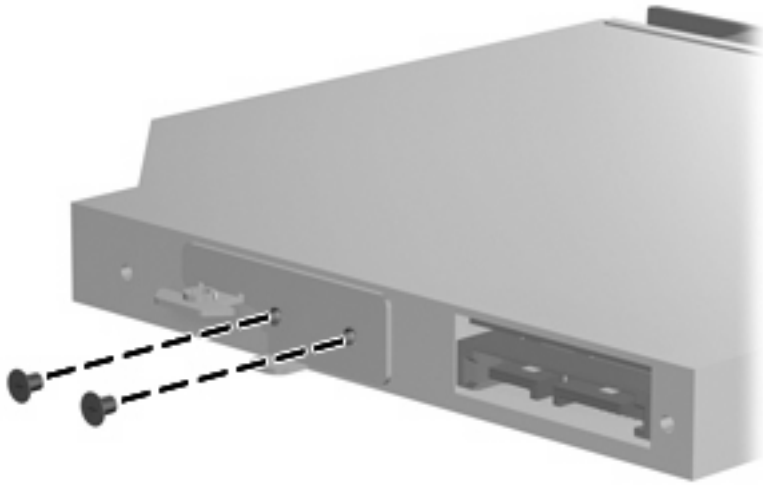

Where used: 2 screws that secure the optical drive bracket to the optical drive

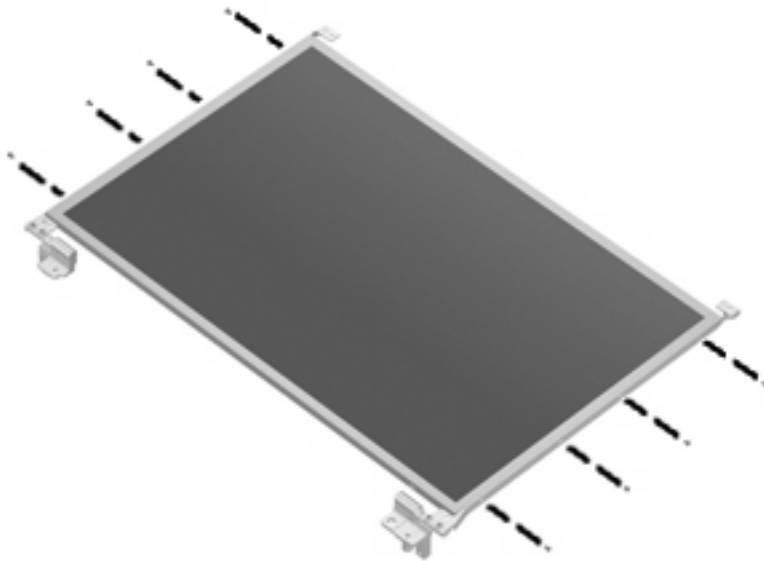

Where used: 8 screws that secure the display hinges to the display panel

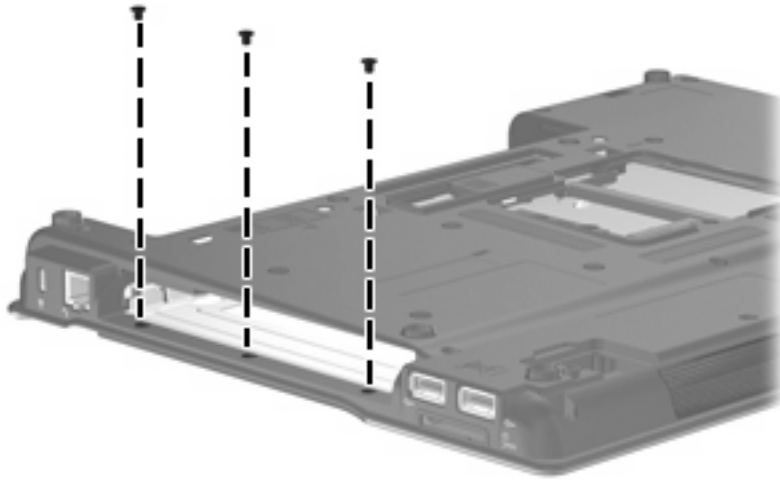

Where used: 3 screws that secure the top cover to the base enclosure

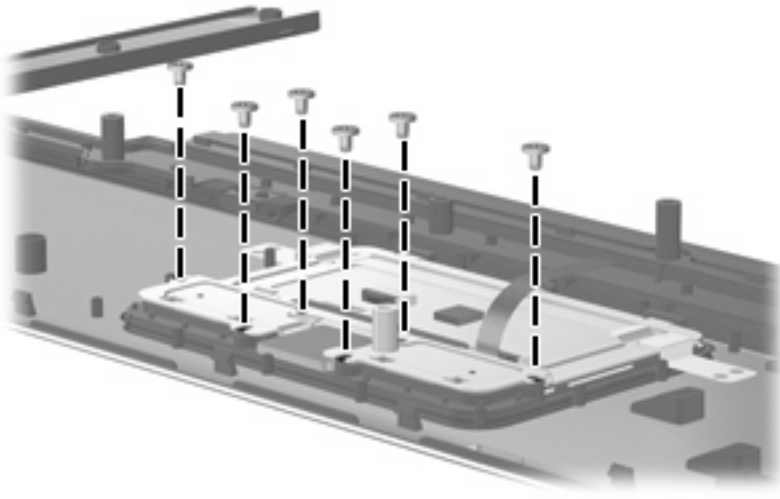

Where used: 6 screws that secure the TouchPad bracket to the top cover

Phillips PM2.5×4.0 screw

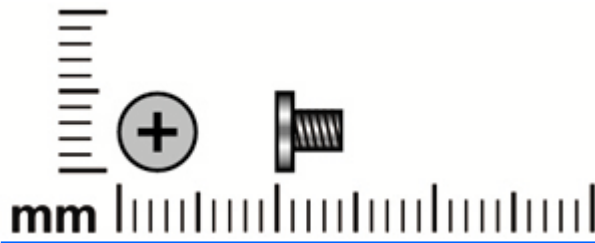

Color	Quantity	Length	Thread	Head diameter
Silver	4	4.0 mm	2.5 mm	5.0 mm

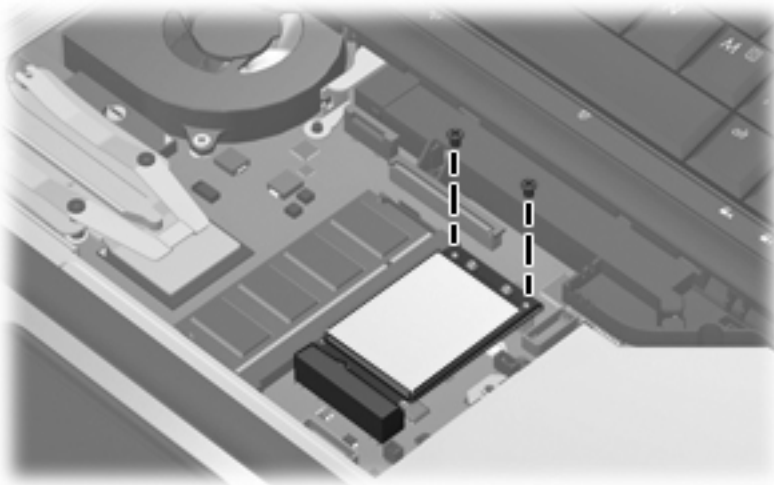

Where used: 2 screws that secure the WLAN module to the system board

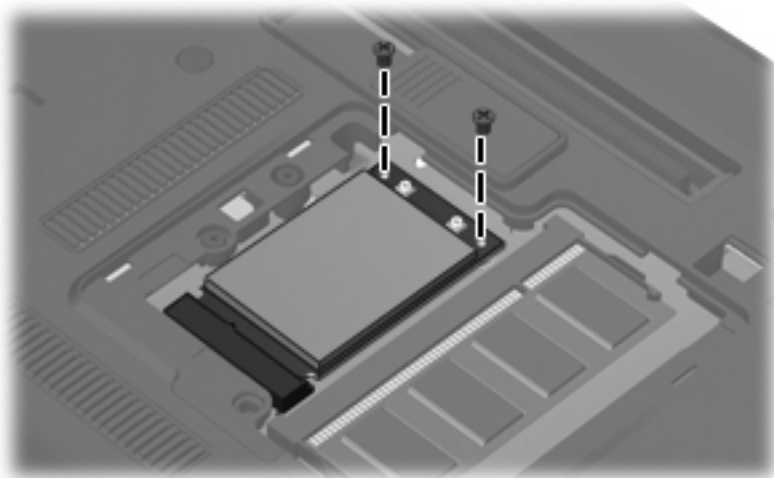

Where used: 2 screws that secure the WWAN module to the system board

Phillips PM2.5×4.0 screw

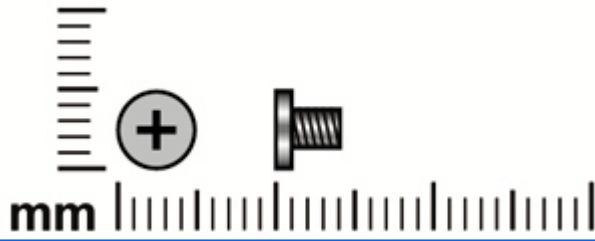

Color	Quantity	Length	Thread	Head diameter
Black	2	4.0 mm	2.5 mm	5.0 mm

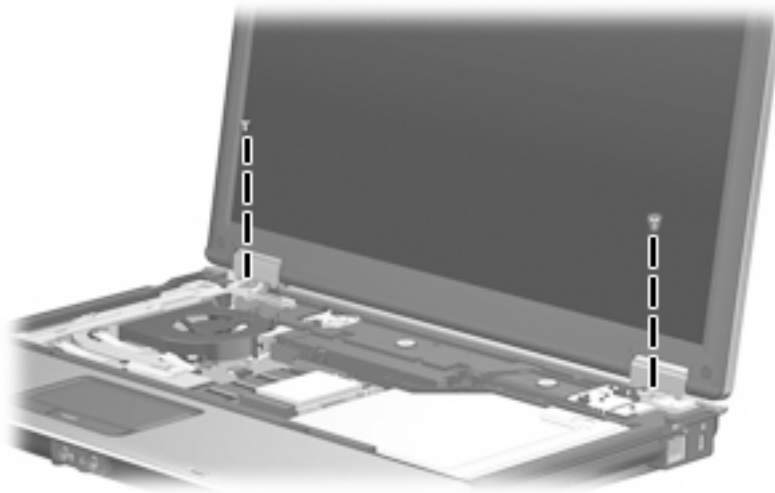

Where used: 2 screws that secure the display hinge covers to the computer

Phillips PM2.0×5.0 screw

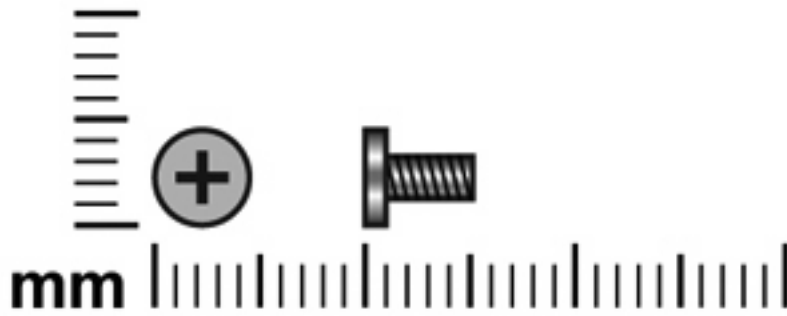

Color	Quantity	Length	Thread	Head diameter
Black	6	5.0 mm	2.0 mm	4.5 mm

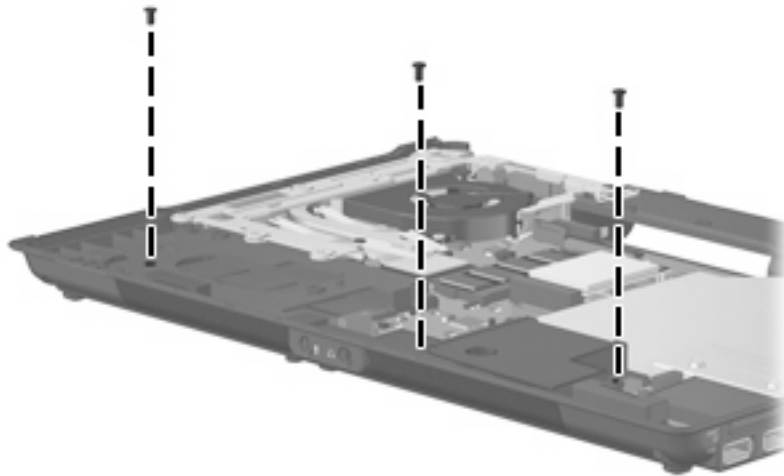

Where used: 3 screws that secure the speaker to the base enclosure

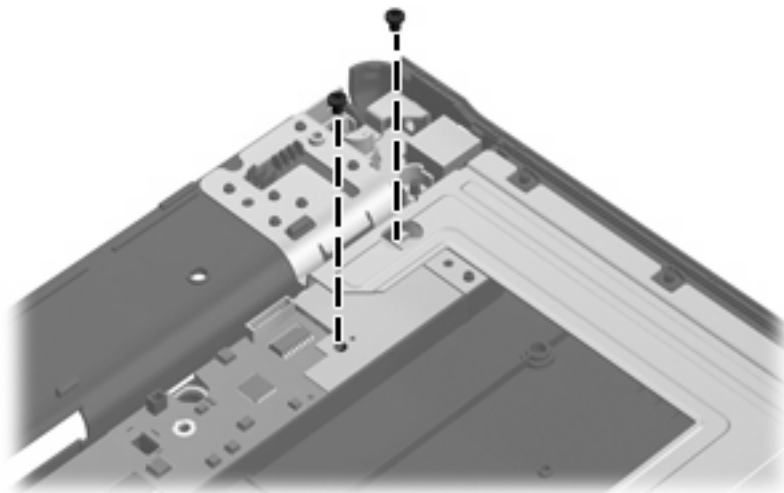

Where used: 2 screws that secure the SIM connector board to the base enclosure on computer models equipped with a WWAN module

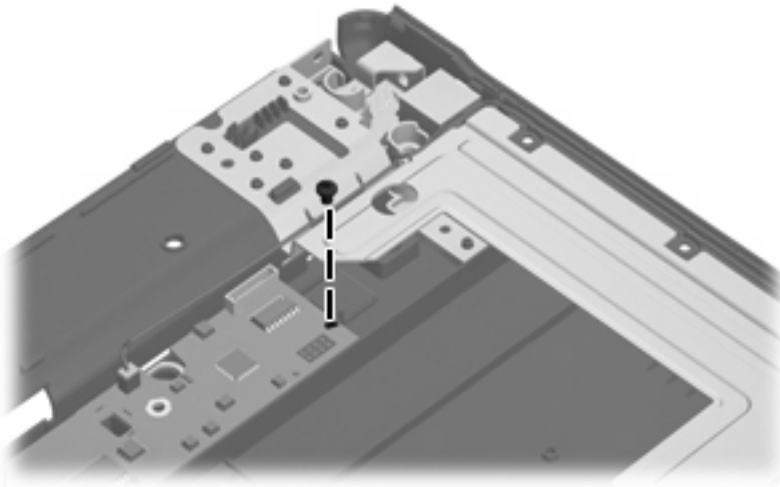

Where used: One screw that secures the system board to the base enclosure on computer models not equipped with a WWAN module

Phillips PM2.5×7.0 captive screw

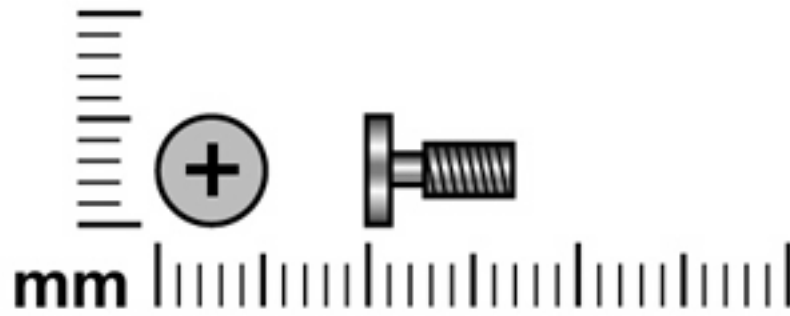

Color	Quantity	Length	Thread	Head diameter
Silver	2	7.0 mm	2.5 mm	5.0 mm

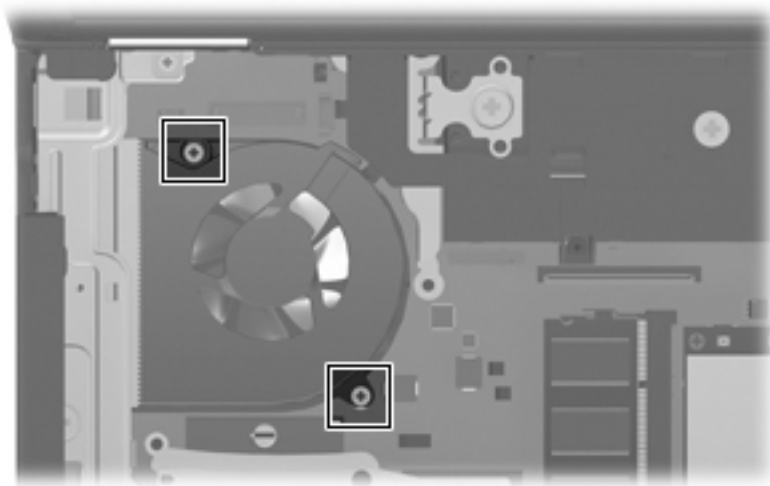

Where used: 2 captive screws that secure the fan to the system board (screws are secured by C-clips)

Phillips PM2.0×4.0 captive screw

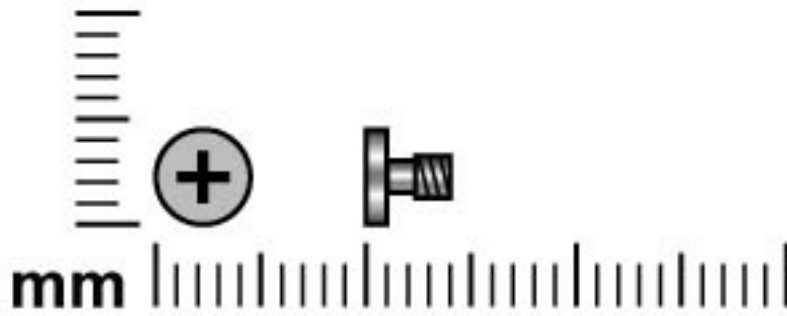

Color	Quantity	Length	Thread	Head diameter
Black	2	4.0 mm	2.0 mm	4.5 mm

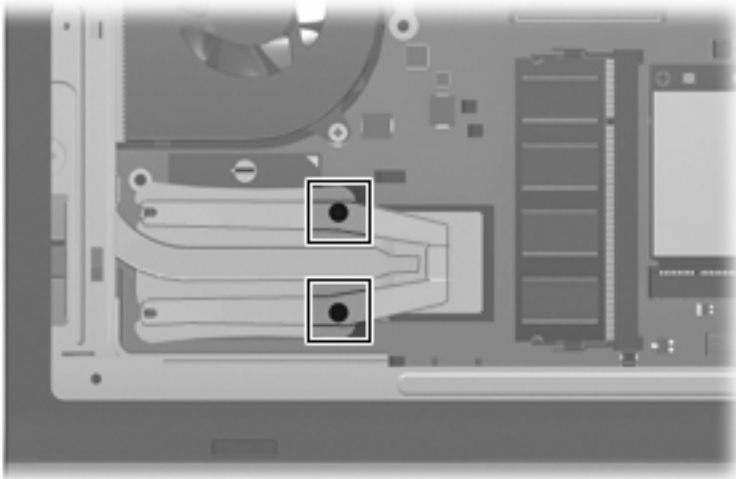

Where used: 2 captive screws that secure the heat sink clip to the system board on HP Compaq 6530b computer models (screws are secured by C-clips)

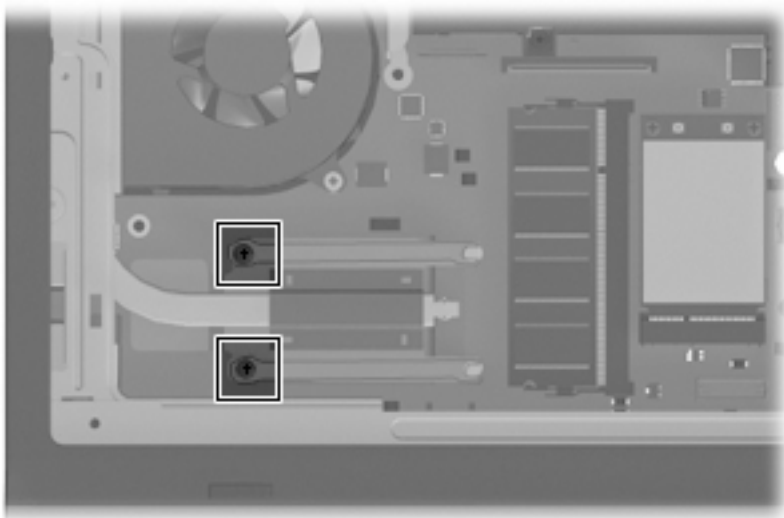

Where used: 2 captive screws that secure the heat sink clip to the system board on HP Compaq 6535b computer models (screws are secured by C-clips)

Torx8 T8M2.5×9.0 screw

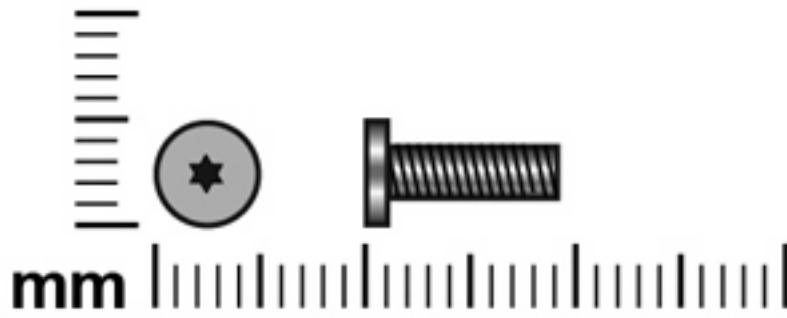

Color	Quantity	Length	Thread	Head diameter
Black	15	9.0 mm	2.5 mm	5.0 mm

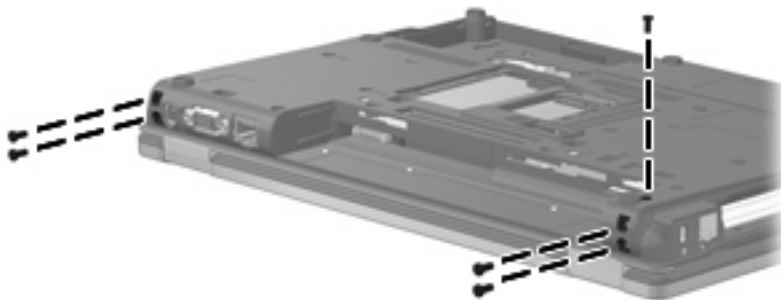

Where used: 5 screws that secure the display assembly to the computer

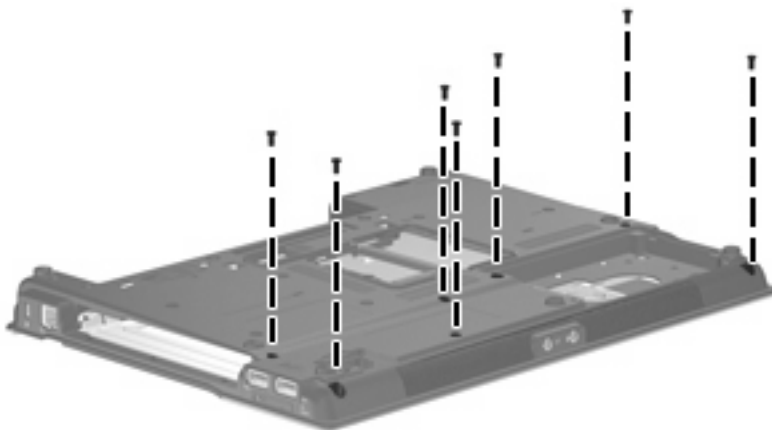

Where used: 7 screws that secure the top cover to the base enclosure

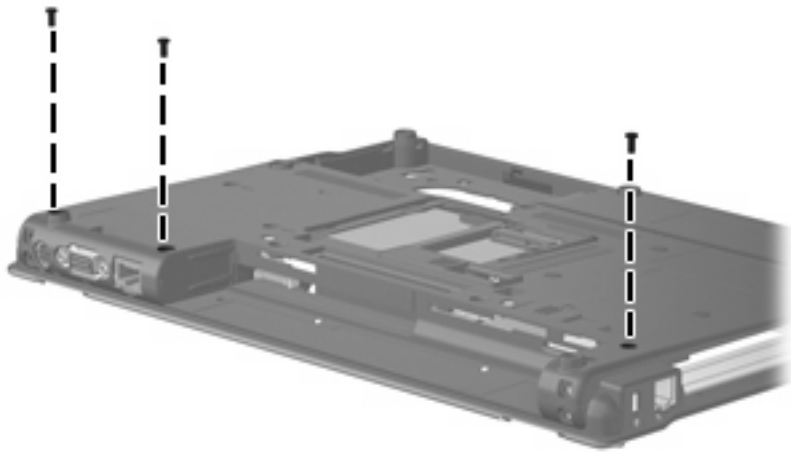

Where used: 3 screws that secure the rear cover to the base enclosure

Torx8 T8M2.5×6.0 screw

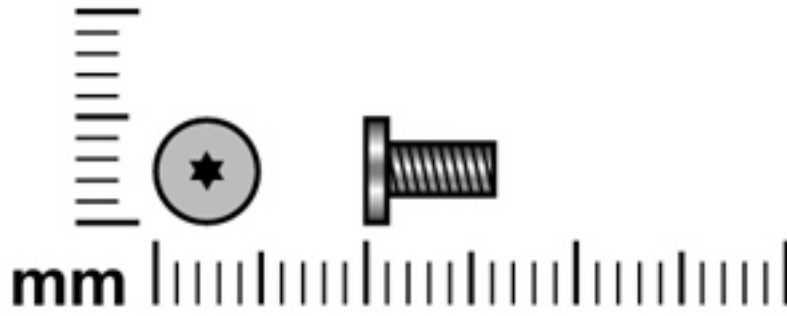

Color	Quantity	Length	Thread	Head diameter
Silver	10	6.0 mm	2.5 mm	5.0 mm

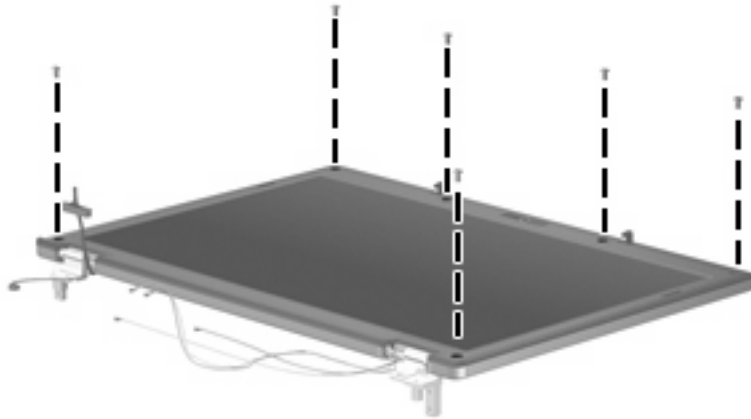

Where used: 6 screws that secure the display bezel to the display enclosure



Where used: 4 screws that secure the display panel to the display enclosure

Phillips PM2.5×3.0 broad-head screw

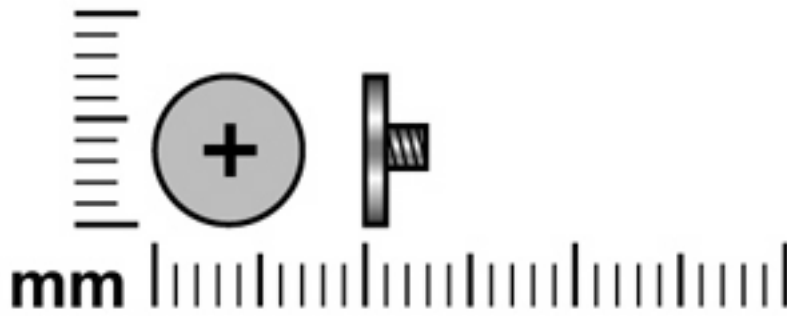

Color	Quantity	Length	Thread	Head diameter
Silver	9	3.0 mm	2.5 mm	7.0 mm

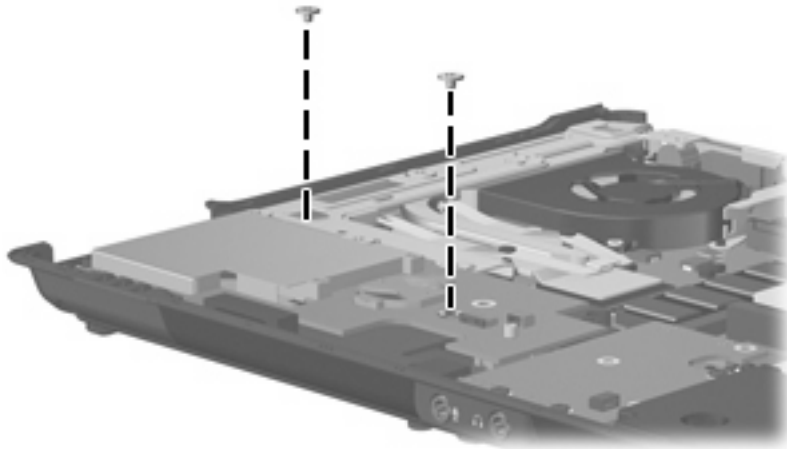

Where used: 2 screws that secure the ExpressCard board to the system board

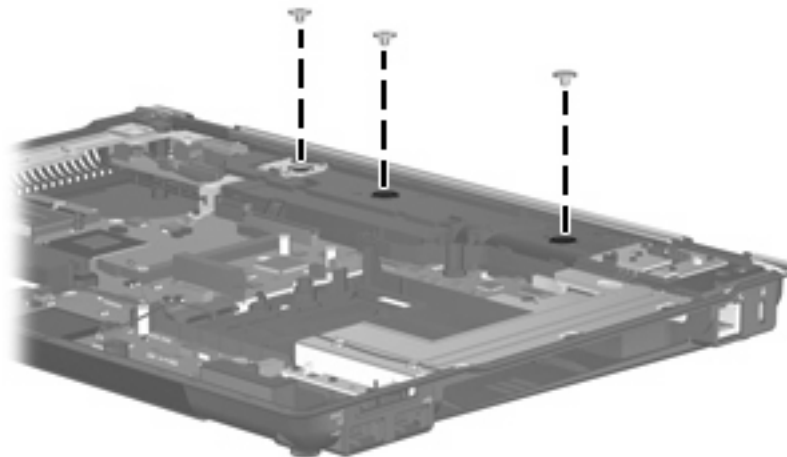

Where used: 3 screws that secure the rear cover to the base enclosure

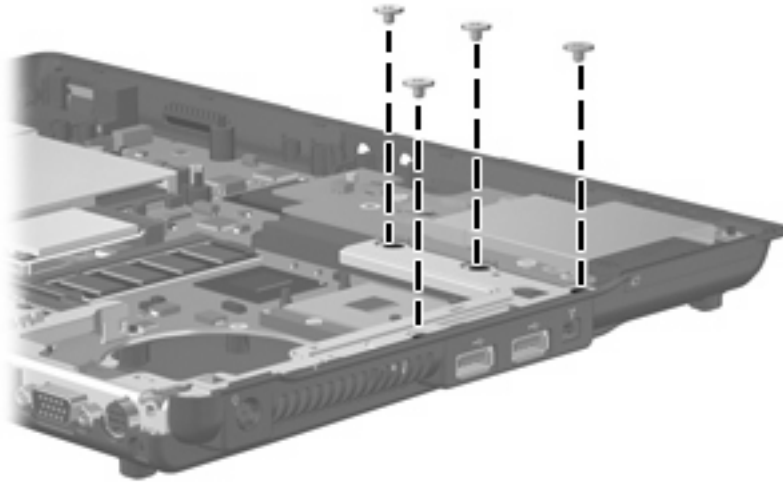

Where used: 4 screws that secure the system board bracket to the base enclosure

Phillips PM2.5×5.0 screw

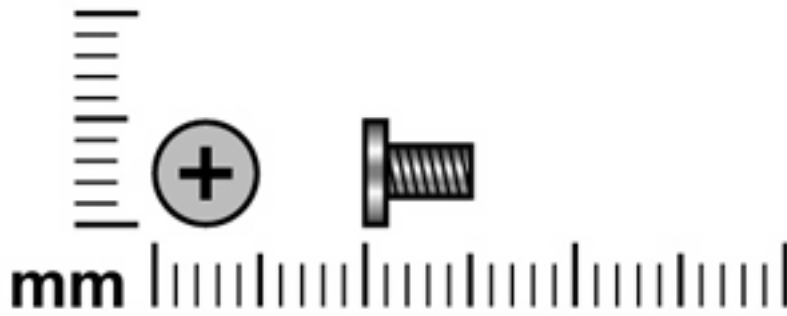

Color	Quantity	Length	Thread	Head diameter
Black	8	5.0 mm	2.5 mm	5.0 mm

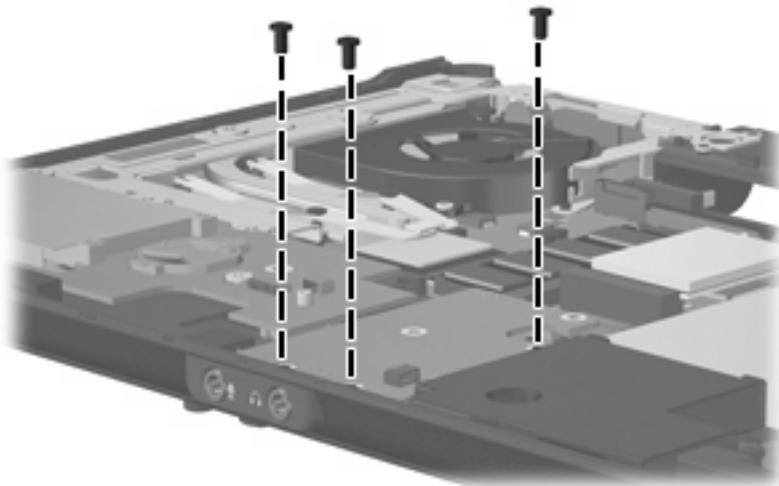

Where used: 3 screws that secure the audio board to the base enclosure

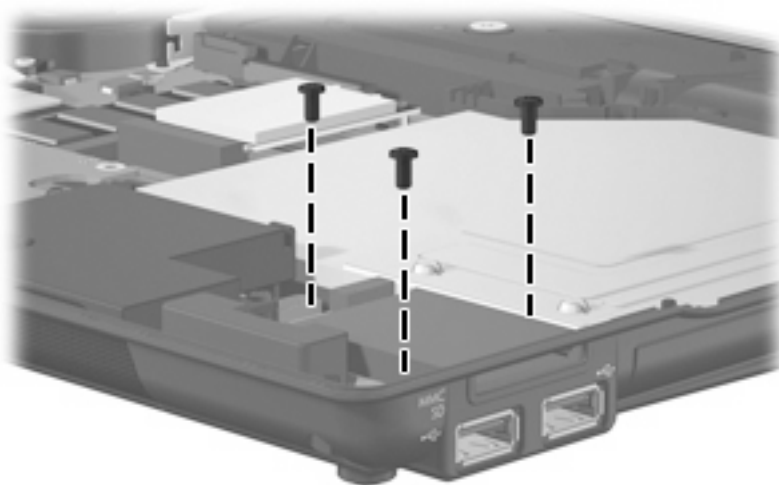

Where used: 3 screws that secure the USB/digital media board to the base enclosure

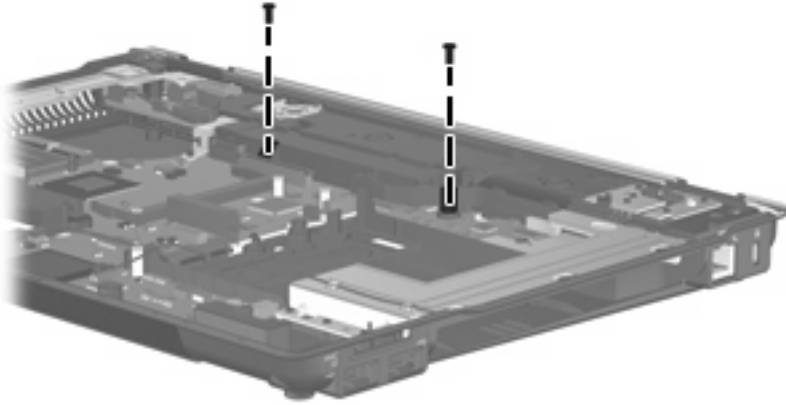

Where used: 2 screws that secure the rear cover to the base enclosure

Phillips PM2.5×3.0 screw

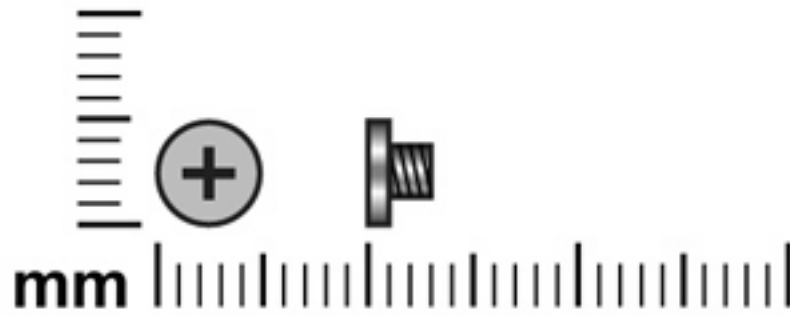

Color	Quantity	Length	Thread	Head diameter
Black	2	3.0 mm	2.5 mm	5.0 mm

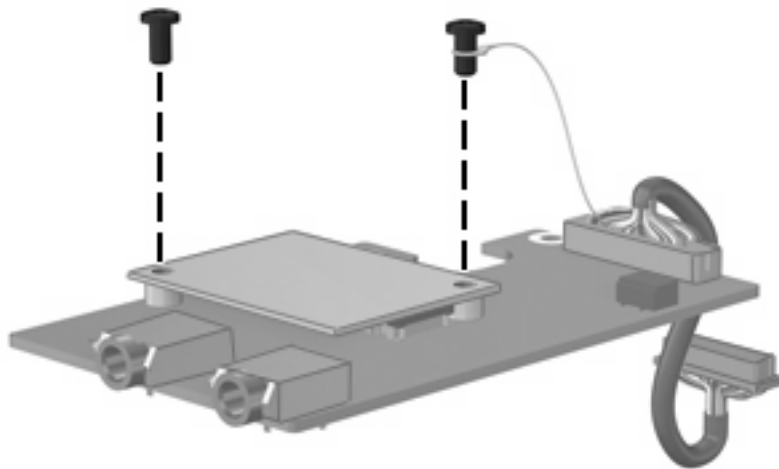

Where used: 2 screws that secure the modem module to the audio board

Hex HM5.0×9.0 screw lock

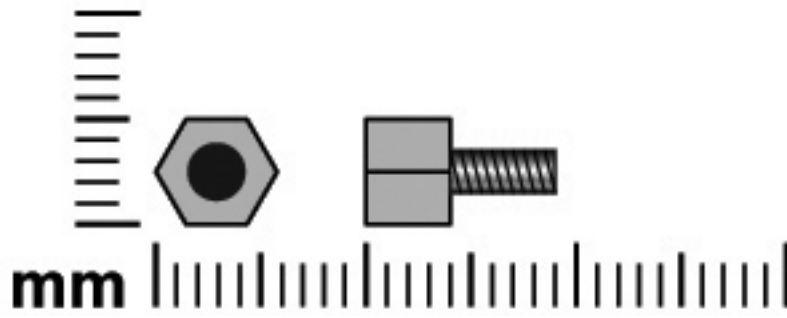

Color	Quantity	Length	Thread	Head diameter
Silver	2	9.0 mm	2.5 mm	5.0 mm

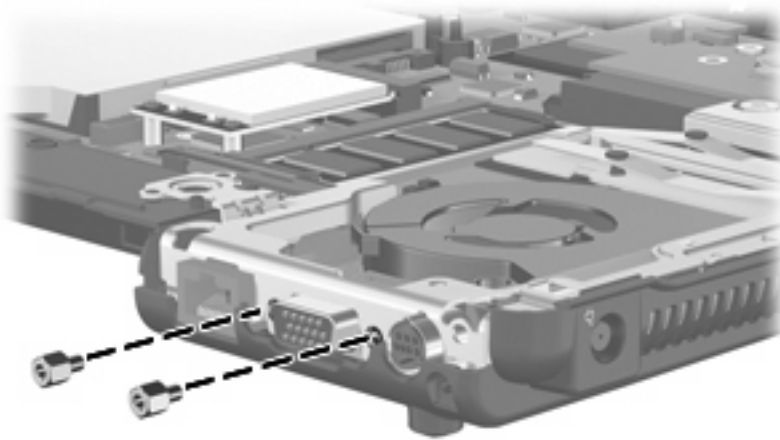

Where used: 2 screw locks that secure the system board bracket to the base enclosure

8 Backup and recovery

Overview

To protect your information, use the Backup and Restore Center to back up individual files and folders, back up your entire hard drive (select models only), or create system restore points. In case of system failure, you can use the backup files to restore the contents of your computer.

Windows Vista® provides the following advanced backup and recovery options:

- Backing up individual files and folders
- Backing up the entire hard drive (select models only)
- Scheduling automatic backups (select models only)
- Creating system restore points
- Recovering individual files
- Restoring the computer to a previous state
- Recovering information using recovery tools

 **NOTE:** For detailed instructions, perform a search for these topics in Help and Support.

Backing up

Backup tips

- Connect the computer to AC power during the backup process.
- Store personal files in the Documents folder and back them up regularly.
- Back up templates that are stored in their associated programs.
- Save customized settings that appear in a window, toolbar, or menu bar by taking a screen shot of your settings. The screen shot can be a time-saver if you have to reset your preferences.

To create a screen shot:

1. Display the screen you want to save.
2. Copy the screen image:

To copy only the active window, press **alt+fn+prt sc**.

To copy the entire screen, press **fn+prt sc**.

3. Open a word-processing document, and then select **Edit > Paste**.

The screen image is added to the document.

4. Save the document.

Backing up your information

Recovery after a system failure is as complete as your most current backup. You should create your initial backup immediately after software setup. As you add new software and data files, you should continue to back up your system on a regular basis to maintain a reasonably current backup.

To create a backup using Backup and Restore Center, follow these steps:

1. Select **Start > All Programs > Maintenance > Backup and Restore Center**.
2. Follow the on-screen instructions to back up your entire computer (select models only) or your files.



NOTE: Windows includes the User Account Control feature to improve the security of your computer. You may be prompted for your permission or password for tasks such as installing software, running utilities, or changing Windows settings. Refer to Help and Support for more information.

Performing a recovery

In case of system failure, use the **f11** recovery tool to recover your original hard drive image. The image includes the Windows operating system and software programs installed at the factory.

 **NOTE:** Windows Vista provides additional recovery tools through the operating system. For additional information, go to Help and Support.

NOTE: If you are unable to boot (start up) your computer, you must purchase a Windows Vista operating system DVD to reboot the computer and repair the operating system. For additional information, refer to the “Recovering information using a Windows Vista operating system DVD (purchased separately)” section in this guide.

Recovering the hard drive using f11

△ **CAUTION:** Using **f11** will completely erase hard drive contents and reformat the hard drive. All files you have created and any software installed on the computer will be permanently removed. The **f11** recovery tool reinstalls the operating system and HP programs and drivers that were installed at the factory. Software not installed at the factory must be reinstalled.

To recover the original hard drive image, follow these steps:

1. If possible, back up all personal files.
2. If possible, check for the presence of the HP Recovery partition. To find the partition, select **Start > Computer**.

 **NOTE:** If the HP Recovery partition has been deleted, you will need to recover your operating system and programs using the Windows Vista operating system DVD and the *Driver Recovery* disc (purchased separately). For additional information, refer to the “Recovering information using a Windows Vista operating system DVD (purchased separately)” section in this guide.

3. Turn on or restart the computer, and then press **esc** while the “Press the ESC key for Startup Menu” message is displayed at the bottom of the screen.
4. Press **f11** while the “Press for recovery” message is displayed on the screen.
5. Follow the on-screen instructions.

Recovering information using a Windows Vista operating system DVD (purchased separately)

If you are unable to boot (start up) your computer, you must purchase a Windows Vista operating system DVD to reboot the computer and repair the operating system. Make sure that your most recent backup (stored on discs or on an external drive) is easily accessible. To order a Windows Vista operating system DVD, go to <http://www.hp.com/support>, select your country or region, and follow the on-screen instructions. You can also order the DVD by calling technical support. For contact information, refer to the Worldwide Telephone Numbers booklet included with the computer.

△ **CAUTION:** Using a Windows Vista operating system DVD will completely erase hard drive contents and reformat the hard drive. All files you have created and any software installed on the computer will be permanently removed. When reformatting is complete, the recovery process will help you restore the operating system, as well as drivers, software, and utilities.

To initiate recovery using a Windows Vista operating system DVD, follow these steps:

 **NOTE:** This process will take several minutes.

1. If possible, back up all personal files.
2. Restart the computer, and then insert the Windows Vista operating system DVD into the optical drive before the Windows operating system loads.
3. When prompted, press any keyboard key.
4. Follow the on-screen instructions.
5. Click **Next**.
6. Select **Repair your computer**.
7. Follow the on-screen instructions.

9 Connector pin assignments

1394

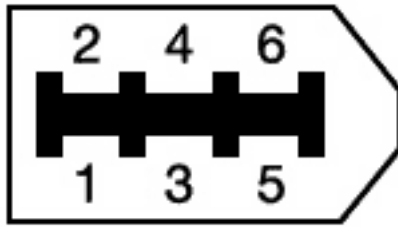

Pin	Assignment
1	Power
2	Ground
3	TPB-
4	TPB+
5	TPA-
6	TPA+

Audio-in (microphone)

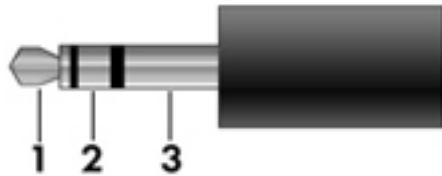

Pin	Signal
1	Audio signal in
2	Audio signal in
3	Ground

Audio-out (headphone)

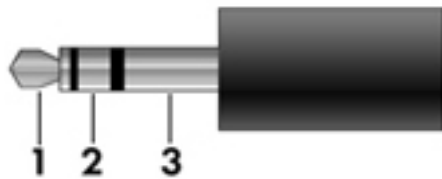

Pin	Signal
1	Audio out, left channel
2	Audio out, right channel
3	Ground

External monitor

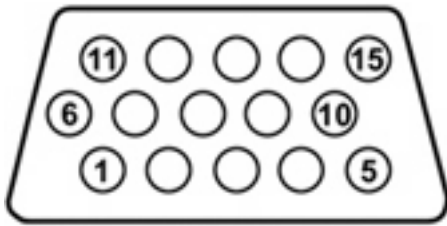

Pin	Signal
1	Red analog
2	Green analog
3	Blue analog
4	Not connected
5	Ground
6	Ground analog
7	Ground analog
8	Ground analog
9	+5 VDC
10	Ground
11	Monitor detect
12	DDC 2B data
13	Horizontal sync
14	Vertical sync
15	DDC 2B clock

RJ-11 (modem)

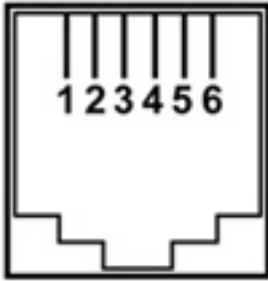

Pin	Signal
1	Unused
2	Tip
3	Ring
4	Unused
5	Unused
6	Unused

RJ-45 (network)

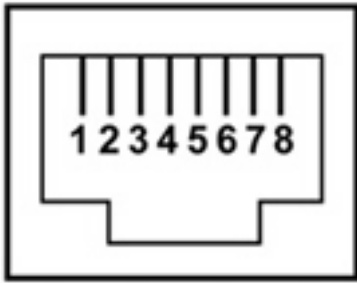

Pin	Signal
1	Transmit +
2	Transmit -
3	Receive +
4	Unused
5	Unused
6	Receive -
7	Unused
8	Unused

S-Video-out



Pin	Signal
1	Ground (Y)
2	Ground (C)
3	Y intensity (luminance)
4	C color (Chrominance)

Serial port

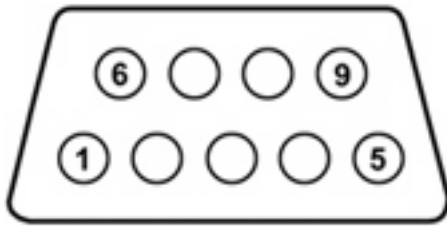

Pin	Signal
1	Data carrier detect
2	Received data
3	Transmitted data
4	Data terminal ready
5	Signal ground
6	Data set ready
7	Request to send
8	Clear to send
9	Ring indicator

Universal Serial Bus

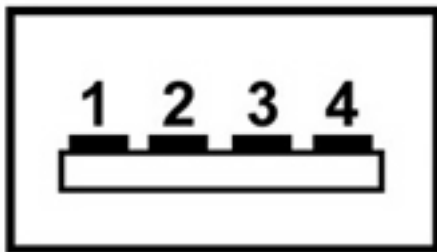

Pin	Signal
1	+5 VDC
2	Data -
3	Data +
4	Ground

10 Power cord set requirements

The wide range input feature of the computer permits it to operate from any line voltage from 100 to 120 volts AC or from 220 to 240 volts AC.

The 3-conductor power cord set included with the computer meets the requirements for use in the country or region where the equipment is purchased.

Power cord sets for use in other countries and regions must meet the requirements of the country or region where the computer is used.

Requirements for all countries and regions

The requirements listed below are applicable to all countries and regions:

- The length of the power cord set must be at least 1.5 m (5.0 ft) and no more than 2.0 m (6.5 ft).
- All power cord sets must be approved by an acceptable accredited agency responsible for evaluation in the country or region where the power cord set will be used.
- The power cord sets must have a minimum current capacity of 10 amps and a nominal voltage rating of 125 or 250 V AC, as required by the power system of each country or region.
- The appliance coupler must meet the mechanical configuration of an EN 60 320/IEC 320 Standard Sheet C13 connector for mating with the appliance inlet on the back of the computer.

Requirements for specific countries and regions

Country/region	Accredited agency	Applicable note number
Australia	EANSW	1
Austria	OVE	1
Belgium	CEBC	1
Canada	CSA	2
Denmark	DEMKO	1
Finland	FIMKO	1
France	UTE	1
Germany	VDE	1
Italy	IMQ	1
Japan	METI	3
The Netherlands	KEMA	1
Norway	NEMKO	1
The People's Republic of China	CCC	5
South Korea	EK	4
Sweden	SEMKO	1
Switzerland	SEV	1
Taiwan	BSMI	4
The United Kingdom	BSI	1
The United States	UL	2

1. The flexible cord must be Type HO5VV-F, 3-conductor, 1.0-mm² conductor size. Power cord set fittings (appliance coupler and wall plug) must bear the certification mark of the agency responsible for evaluation in the country or region where it will be used.
2. The flexible cord must be Type SPT-3 or equivalent, No. 18 AWG, 3-conductor. The wall plug must be a two-pole grounding type with a NEMA 5-15P (15 A, 125 V) or NEMA 6-15P (15 A, 250 V) configuration.
3. The appliance coupler, flexible cord, and wall plug must bear a "T" mark and registration number in accordance with the Japanese Dentori Law. The flexible cord must be Type VCT or VCTF, 3-conductor, 1.00-mm² conductor size. The wall plug must be a two-pole grounding type with a Japanese Industrial Standard C8303 (7 A, 125 V) configuration.
4. The flexible cord must be Type RVV, 3-conductor, 0.75-mm² conductor size. Power cord set fittings (appliance coupler and wall plug) must bear the certification mark of the agency responsible for evaluation in the country or region where it will be used.
5. The flexible cord must be Type VCTF, 3-conductor, 0.75-mm² conductor size. Power cord set fittings (appliance coupler and wall plug) must bear the certification mark of the agency responsible for evaluation in the country or region where it will be used.

11 Recycling

Battery

When a battery has reached the end of its useful life, do not dispose of the battery in general household waste. Follow the local laws and regulations in your area for computer battery disposal.

Display

-
- ⚠ **WARNING!** The backlight contains mercury. Exercise caution when removing and handling the backlight to avoid damaging this component and causing exposure to the mercury.
 - ⚠ **CAUTION:** The procedures in this appendix can result in damage to display components. The only components intended for recycling purposes are the liquid crystal display (LCD) panel and the backlight. Careful handling must be exercised when removing these components. When you remove these components, handle them carefully.
 - 📄 **NOTE: Materials Disposal.** This HP product contains mercury in the backlight in the display assembly that might require special handling at end-of-life. Disposal of mercury may be regulated because of environmental considerations. For disposal or recycling information, contact your local authorities, or see the Electronic Industries Alliance (EIA) Web site at <http://www.eiae.org>.
-

This section provides disassembly instructions for the display assembly. The display assembly must be disassembled to gain access to the backlight **(1)** and the liquid crystal display (LCD) panel **(2)**.



-
- 📄 **NOTE:** The procedures provided in this appendix are general disassembly instructions. Specific details, such as screw sizes, quantities, and locations, and component shapes and sizes, may vary from one computer model to another.
-

Perform the following steps to disassemble the display assembly:

1. Remove all screw covers (1) and screws (2) that secure the display bezel to the display assembly.

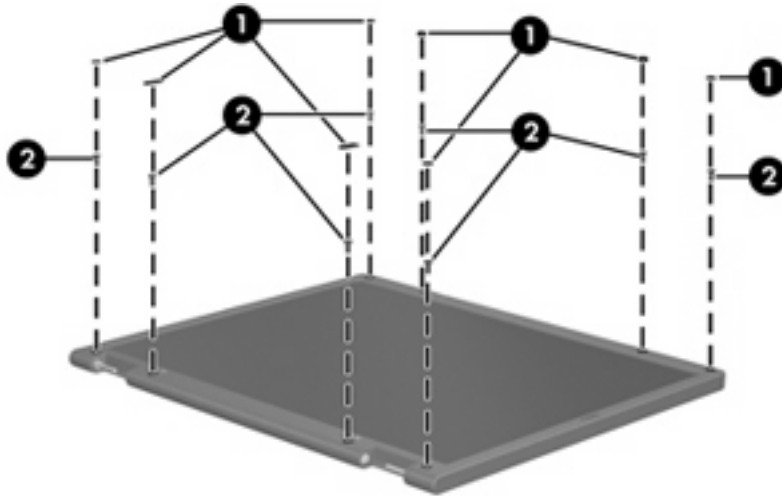

2. Lift up and out on the left and right inside edges (1) and the top and bottom inside edges (2) of the display bezel until the bezel disengages from the display assembly.

3. Remove the display bezel (3).

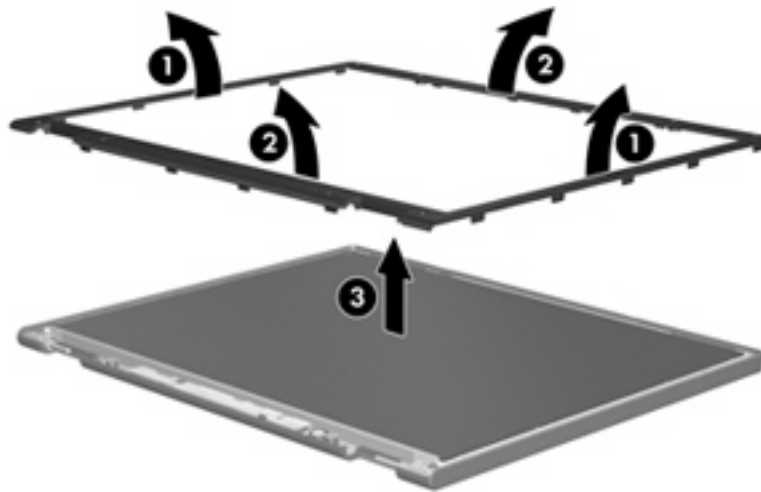

4. Disconnect all display panel cables (1) from the display inverter and remove the inverter (2).

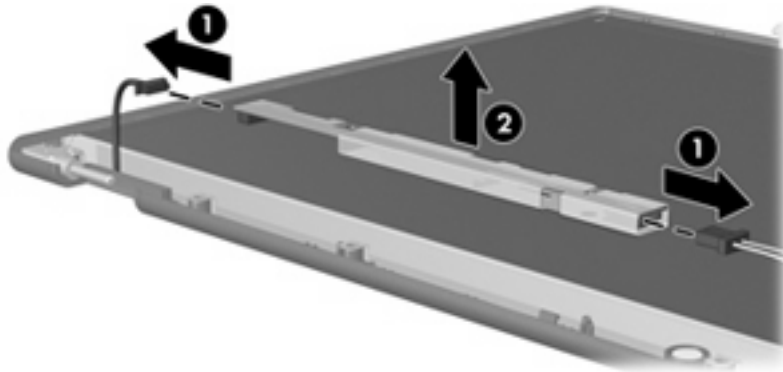

5. Remove all screws (1) that secure the display panel assembly to the display enclosure.
6. Remove the display panel assembly (2) from the display enclosure.

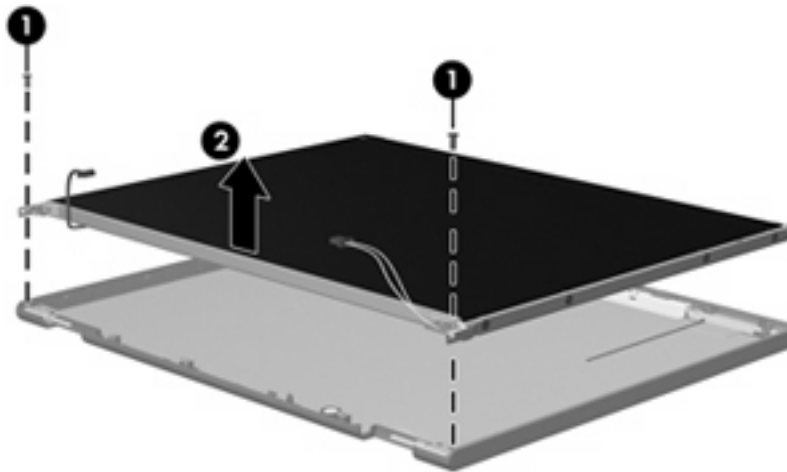

7. Turn the display panel assembly upside down.
8. Remove all screws that secure the display panel frame to the display panel.

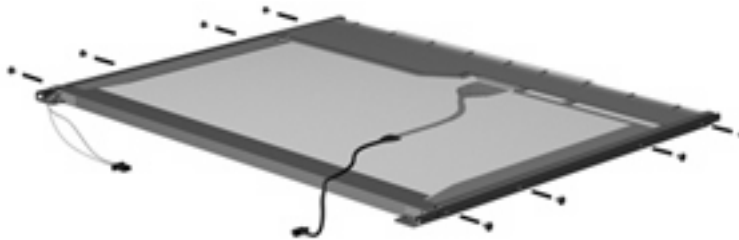

9. Use a sharp-edged tool to cut the tape (1) that secures the sides of the display panel to the display panel frame.

10. Remove the display panel frame (2) from the display panel.

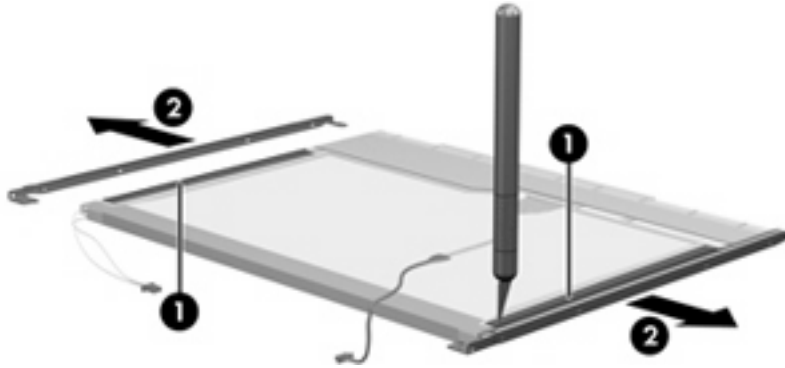

11. Remove the screws (1) that secure the backlight cover to the display panel.
12. Lift the top edge of the backlight cover (2) and swing it outward.

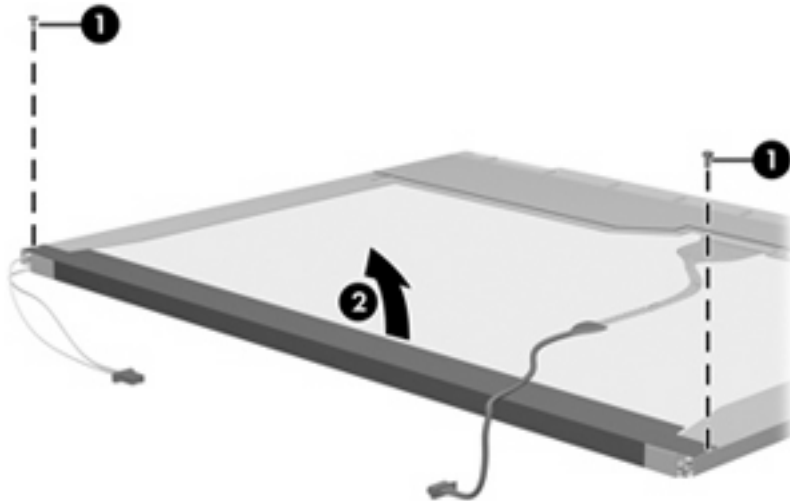

13. Remove the backlight cover.
14. Turn the display panel right-side up.

15. Remove the backlight cables (1) from the clip (2) in the display panel.

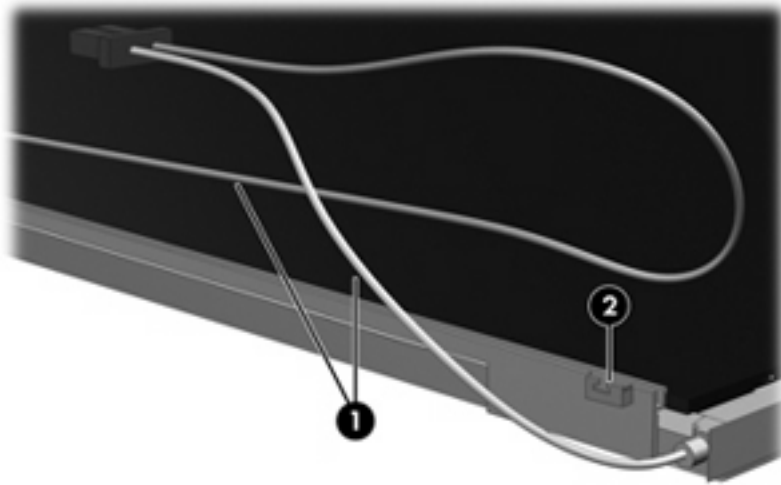

16. Turn the display panel upside down.

⚠ WARNING! The backlight contains mercury. Exercise caution when removing and handling the backlight to avoid damaging this component and causing exposure to the mercury.

17. Remove the backlight frame from the display panel.

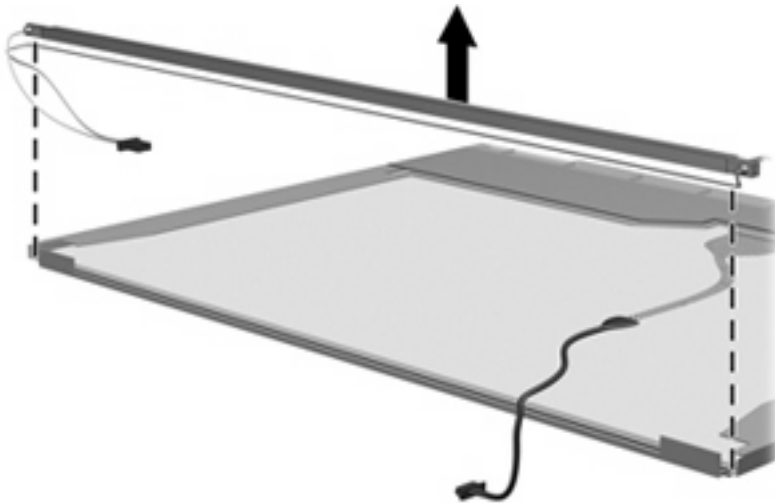

18. Remove the backlight from the backlight frame.

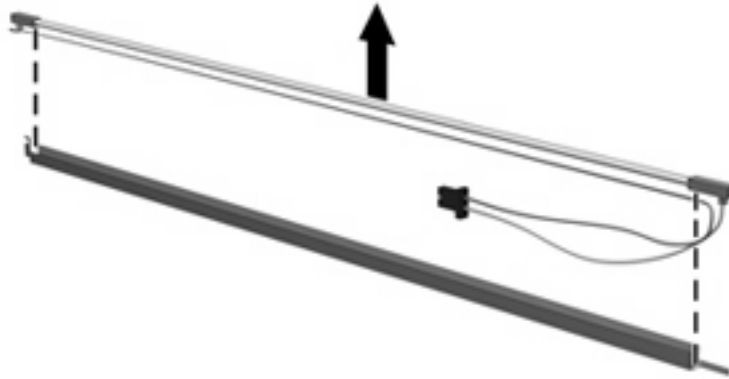

19. Disconnect the display panel cable (1) from the LCD panel.
20. Remove the screws (2) that secure the LCD panel to the display rear panel.
21. Release the LCD panel (3) from the display rear panel.
22. Release the tape (4) that secures the LCD panel to the display rear panel.

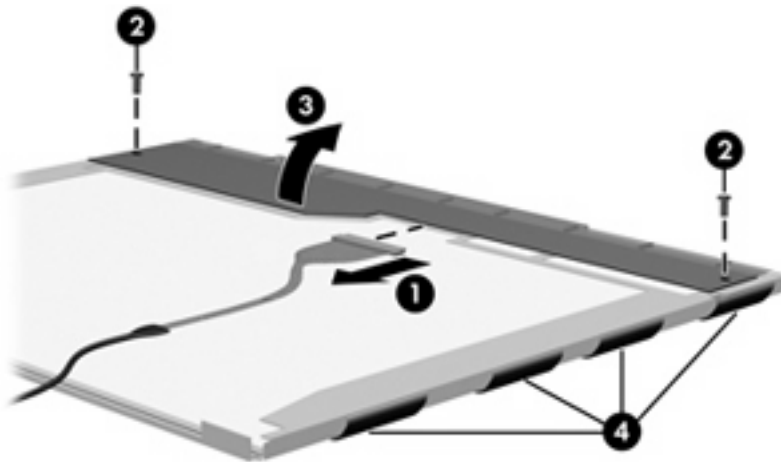

23. Remove the LCD panel.

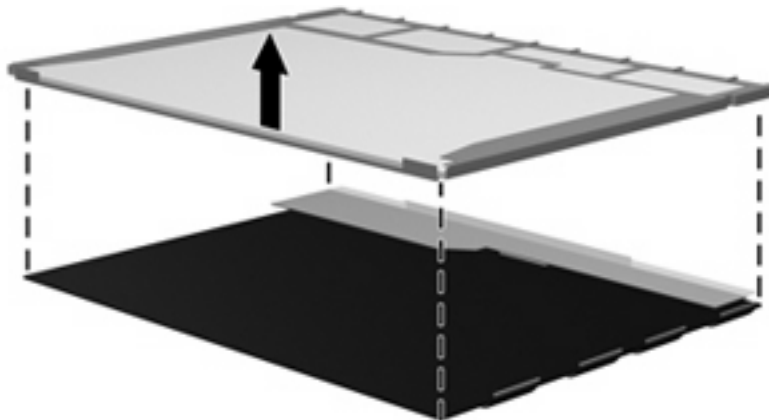

24. Recycle the LCD panel and backlight.

Index

Symbols/Numerics

1394 port
location 16
pin assignments 148

A

AC adapter, spare part
numbers 31, 32
accessory battery connector 18
antenna
disconnecting 58, 64
locations 9
removal 79
spare part numbers 23, 35,
79, 80
audio board
removal 87
spare part number 25, 32,
87
audio, product description 4
audio-in jack
location 14
pin assignments 148
audio-out jack
location 14
pin assignments 148

B

backing up files 144
Backup and Restore Center 144
backup tips 144
base enclosure, spare part
numbers 25, 35
battery
removal 46
spare part numbers 26, 35,
46
battery bay 18
battery light 14
battery release latch 18

Bluetooth compartment 18
Bluetooth module
removal 50
spare part numbers 27, 32,
36, 50
Bluetooth module cable
illustrated 29
removal 97
Bluetooth module compartment
cover
illustrated 28
removal 50
boot options 106
boot order 107
bottom components 18
built-in device
Bluetooth device radio 108
fingerprint reader 108
modem 108
Network Interface Controller
(LAN) 108
Wake on LAN 108
wireless button 107
WWAN device radio 107
built-in device options 107
button components 10
buttons
info 11
power 10
presentation 11
TouchPad 13
volume mute 11
wireless 11

C

Cable Kit
contents 29
spare part number 24, 29,
34
cables, service considerations 39

chipset, product description 2
CMOS clearing 43
components
bottom 18
buttons 10
display 9
fingerprint reader 10
front 14
keys 12
left-side 16
pointing device 13
rear 17
right-side 15
switches 10
top 9
TouchPad 13
computer feet
locations 45
spare part number 45
Computer Setup
accessing 103
Diagnostics menu 106
File menu 105
navigating and selecting 103
restoring factory settings 104
Security menu 105
System Configuration
menu 106
using 103
computer specifications 109
connectors, service
considerations 39
creating a backup 144

D

device configurations 107
Diagnostics menu 106
Disk Sanitizer 106

- diskette drive
 - precautions 39
 - product description 4
 - display assembly
 - removal 74
 - spare part numbers 21, 33, 37, 74
 - display bezel
 - removal 77
 - spare part numbers 22, 35, 36, 78
 - display component recycling 156
 - display components 9
 - display enclosure, spare part number 23, 35
 - display hinge
 - removal 78
 - spare part number 22, 35, 79
 - display hinge cover
 - spare part number 22, 35, 75, 76
 - display inverter
 - removal 48
 - spare part numbers 22, 35, 37, 48
 - Display Logo Kit, spare part number 23, 35
 - display panel cable, spare part number 23, 35
 - display panel, removal 78
 - display release latch 14
 - Display Rubber Kit, spare part number 23, 35
 - Display Screw Kit, spare part number 23, 35
 - display specifications 110
 - docking connector 18
 - docking, product description 6
 - drive light 14
 - DriveLock password 105
 - DriveLock, automatic 105
 - drives
 - boot order 107
 - preventing damage 39
 - Dual Core CPU 107
 - DVD-ROM Drive
 - precautions 39
 - removal 55
 - spare part number 26, 30, 33, 55
 - specifications 114
 - DVD/CD-RW Combo Drive
 - precautions 39
 - removal 55
 - spare part number 26, 30, 33, 55
 - specifications 113
 - DVD±RW and CD-RW Combo Drive
 - precautions 39
 - removal 55
 - spare part number 26, 30, 33, 55
 - specifications 112
- E**
- electrostatic discharge 40
 - embedded numeric keypad keys 12
 - esc key 12
 - Ethernet, product description 5
 - Execution Disable 107
 - ExpressCard board
 - removal 86
 - spare part number 25, 32, 86
 - ExpressCard slot 16
 - external media cards, product description 5
 - external monitor port
 - location 17
 - pin assignments 149
- F**
- f11 recovery 145
 - fan
 - removal 66
 - spare part number 25, 35, 66
 - feet
 - locations 45
 - spare part number 45
 - fingerprint reader 10, 13
 - fingerprint reader board, removal 85
 - fn key 12
 - front components 14
 - function key 12
- G**
- graphics, product description 2
 - grounding equipment and methods 42
- H**
- hard disk test 106
 - hard drive
 - precautions 39
 - product description 3
 - removal 52
 - spare part numbers 26, 30, 33, 35, 52
 - specifications 111
 - hard drive bay 18
 - hard drive bay cover
 - illustrated 28
 - removal 52
 - hard drive bracket, removal 53
 - hard drive recovery 145
 - headphone jack
 - location 14
 - pin assignments 148
 - heat sink
 - removal 68
 - spare part numbers 25, 35, 36, 68
 - hinge
 - removal 78
 - spare part number 22, 35, 79
 - hinge cover
 - spare part number 22, 35, 75, 76
 - HP QuickLook 107
- I**
- I/O address specifications 117
 - info button 11
 - internal display switch 10
 - interrupt specifications 116
- J**
- jacks
 - audio-in 14
 - audio-out 14
 - headphone 14
 - microphone 14
 - modem 16, 17
 - network 17
 - RJ-11 16, 17

- RJ-45 17
- S-Video-out 17
- K**
- key components 12
- keyboard
 - product description 6
 - removal 61
 - spare part numbers 23, 33, 61
- keys
 - embedded numeric keypad 12
 - esc 12
 - fn 12
 - function 12
 - Windows applications 12
 - Windows logo 12
- L**
- LAN Power Save 107
- language, changing in Computer Setup 106
- left-side components 16
- legacy support, USB 103, 107
- lights
 - battery 14
 - drive 14
 - power 14
 - wireless 14
- M**
- mass storage devices, spare part numbers 30
- Media Card Reader 15
- memory map specifications 119
- memory module
 - product description 2
 - removal 59, 63
 - spare part numbers 24, 32, 59, 63
- memory module compartment 18
- memory/WLAN module
 - compartment cover
 - illustrated 28
 - removal 58
- microphone extension cable
 - illustrated 29
 - removal 102
- microphone jack
 - location 14
 - pin assignments 148
- microphones 9
- model name 1
- modem jack
 - location 17
 - pin assignments 150
- modem module
 - product description 4
 - removal 89
 - spare part numbers 25, 37, 89
- modem module cable
 - illustrated 29
 - removal 96
- monitor port
 - location 17
 - pin assignments 149
- N**
- network jack
 - location 17
 - pin assignments 151
- O**
- operating system, product description 7
- optical drive
 - location 15, 16
 - precautions 39
 - product description 4
 - removal 55
 - spare part numbers 26, 30, 55
 - specifications 112, 113, 114
- P**
- packing guidelines 41
- panels, product description 2
- parallel port mode 107
- password clearing 43
- passwords 105
- PC Card slot bezel, illustrated 28
- pin assignments
 - 1394 port 148
 - audio-in jack 148
 - audio-out jack 148
 - external monitor port 149
 - headphone jack 148
 - microphone jack 148
 - modem jack 150
 - monitor port 149
 - network jack 151
 - RJ-11 150
 - RJ-45 jack 151
 - S-Video-out jack 152
 - serial port 153
 - Universal Serial Bus (USB) port 153
- plastic parts 38
- Plastics Kit
 - contents 28
 - spare part number 24, 28, 35
- pointing device components 13
- pointing devices, product description 6
- port options
 - 1394 port 108
 - ExpressCard slot 108
 - flash media reader 108
 - parallel port 108
 - serial port 108
 - smart card slot 108
 - USB port 108
- ports
 - 1394 16
 - external monitor 17
 - monitor 17
 - product description 6
 - USB 16
- power button 10
- power connector 16
- power cord
 - set requirements 154
 - spare part numbers 31, 32
- power light 14
- power requirements, product description 6
- presentation button 11
- processor
 - product description 1
 - removal 72
 - spare part numbers 25, 36, 72
- product description
 - audio 4
 - chipset 2
 - diskette drive 4
 - docking 6

- Ethernet 5
- external media cards 5
- graphics 2
- hard drives 3
- keyboard 6
- memory module 2
- modem module 4
- operating system 7
- optical drives 4
- panels 2
- pointing devices 6
- ports 6
- power requirements 6
- processors 1
- product name 1
- security 7
- serviceability 8
- wireless 5
- product name 1
- R**
- rear components 17
- rear cover
 - removal 93
 - spare part number 25, 35, 93
- recovering information 146
- recovery partition 145
- removal/replacement
 - preliminaries 38
 - procedures 44
- restore security defaults 108
- restoring the factory settings 104
- restoring the hard drive 146
- right-side components 15
- RJ-11 jack
 - location 17
 - pin assignments 150
- RJ-45 jack
 - location 17
 - pin assignments 151
- RTC battery
 - removal 54
 - spare part number 26, 32, 54
- Rubber Kit, spare part
 - number 26, 35
- run-in test 106

- S**
- S-Video-out jack
 - location 17
 - pin assignments 152
- SATA (Serial Advanced Technology Attachment) device
 - AHCI (Advanced Host Controller Interface) 107
 - IDE (Integrated Drive Electronics) 107
- Screw Kit
 - contents 120
 - spare part number 31, 35
- screw listing 120
- Secondary Battery Fast Charge 107
- security cable slot 16, 17
- Security menu
 - Automatic DriveLock 105
 - change password 105
 - Disk Sanitizer 106
 - DriveLock 105
 - fingerprint reader reset 105
 - HP SpareKey 105
 - HP SpareKey Enrollment 105
 - password policy 105
 - System IDs 106
 - TPM embedded Security 106
 - user management 105
- security, product description 7
- serial port
 - location 15
 - pin assignments 153
- service considerations 38
- service tag 19, 44
- serviceability, product
 - description 8
- set security level 108
- SIM connector board
 - removal 95
 - spare part number 25, 32, 95
- SIM slot 18
- SIM, removal 47
- speaker
 - removal 91
 - spare part number 25, 34, 91
- speakers 14

- specifications
 - computer 109
 - display 110
 - DVD-ROM Drive 114
 - DVD/CD-RW Combo Drive 113
 - DVD±RW and CD-RW Combo Drive 112
 - hard drive 111
 - I/O addresses 117
 - interrupts 116
 - memory map 119
 - optical drive 112, 113, 114
 - system DMA 115
- start-up test 106
- static-shielding materials 42
- switch components 10
- switch cover
 - removal 65
 - spare part number 23, 34, 65
- system board
 - removal 99
 - spare part numbers 24, 32, 36, 99
- system board bracket,
 - removal 100
- System Configuration menu 106
- system date and time 105
- System Diagnostics menu 106
- system DMA 115
- system fan 107
- system IDs 106
- system information 105
- system memory map 119
- T**
- thermal material,
 - replacement 69, 71
- tools required 38
- top components 9
- top cover
 - removal 81
 - spare part number 25, 34, 81
- TouchPad
 - location 13
- TouchPad assembly
 - spare part numbers 24, 33

- TouchPad board
 - removal 83
 - spare part numbers 83
- TouchPad button 13
- TouchPad components 13
- TouchPad scroll zone 13
- transporting guidelines 41
- Trusted Platform Module
 - Embedded Security 106
- TXT (Intel Trusted Execution Technology) 107

- WWAN module
 - removal 64
 - spare part number 25, 32, 64

U

- Unified Extensible Firmware Interface (UEFI) 107
- unknown password 43
- USB legacy support 103, 107
- USB port
 - location 15, 16
 - pin assignments 153
- USB/digital media board
 - removal 92
 - spare part number 25, 32, 92

V

- vents 16, 18
- Virtualization Technology 107
- volume mure button 11
- volume scroll zone 11

W

- webcam light 10
- webcam, location 10
- Windows applications key 12
- Windows logo key 12
- Windows Vista operating system
 - DVD 146
- wireless antenna
 - disconnecting 58, 64
 - locations 9
 - removal 79
 - spare part numbers 79, 80
- wireless button 11
- wireless light 14
- wireless, product description 5
- WLAN module
 - removal 57
 - spare part numbers 26, 35, 36, 57
- workstation guidelines 41

