



SUPERSERVER

5018A-LTN4



User's Manual

Revision 1.0

The information in this User's Manual has been carefully reviewed and is believed to be accurate. The vendor assumes no responsibility for any inaccuracies that may be contained in this document, makes no commitment to update or to keep current the information in this manual, or to notify any person or organization of the updates. **Please Note: For the most up-to-date version of this manual, please see our web site at www.supermicro.com.**

Super Micro Computer, Inc. ("Supermicro") reserves the right to make changes to the product described in this manual at any time and without notice. This product, including software and documentation, is the property of Supermicro and/or its licensors, and is supplied only under a license. Any use or reproduction of this product is not allowed, except as expressly permitted by the terms of said license.

IN NO EVENT WILL SUPERMICRO BE LIABLE FOR DIRECT, INDIRECT, SPECIAL, INCIDENTAL, SPECULATIVE OR CONSEQUENTIAL DAMAGES ARISING FROM THE USE OR INABILITY TO USE THIS PRODUCT OR DOCUMENTATION, EVEN IF ADVISED OF THE POSSIBILITY OF SUCH DAMAGES. IN PARTICULAR, SUPERMICRO SHALL NOT HAVE LIABILITY FOR ANY HARDWARE, SOFTWARE, OR DATA STORED OR USED WITH THE PRODUCT, INCLUDING THE COSTS OF REPAIRING, REPLACING, INTEGRATING, INSTALLING OR RECOVERING SUCH HARDWARE, SOFTWARE, OR DATA.

Any disputes arising between manufacturer and customer shall be governed by the laws of Santa Clara County in the State of California, USA. The State of California, County of Santa Clara shall be the exclusive venue for the resolution of any such disputes. Super Micro's total liability for all claims will not exceed the price paid for the hardware product.

FCC Statement: This equipment has been tested and found to comply with the limits for a Class B digital device pursuant to Part 15 of the FCC Rules. These limits are designed to provide reasonable protection against harmful interference when the equipment is operated in a commercial environment. This equipment generates, uses, and can radiate radio frequency energy and, if not installed and used in accordance with the manufacturer's instruction manual, may cause harmful interference with radio communications. Operation of this equipment in a residential area is likely to cause harmful interference, in which case you will be required to correct the interference at your own expense.

California Best Management Practices Regulations for Perchlorate Materials: This Perchlorate warning applies only to products containing CR (Manganese Dioxide) Lithium coin cells. "Perchlorate Material-special handling may apply. See www.dtsc.ca.gov/hazardouswaste/perchlorate"

WARNING: Handling of lead solder materials used in this product may expose you to lead, a chemical known to the State of California to cause birth defects and other reproductive harm.

Manual Revision 1.0
Release Date: May 12, 2016

Unless you request and receive written permission from Super Micro Computer, Inc., you may not copy any part of this document.

Information in this document is subject to change without notice. Other products and companies referred to herein are trademarks or registered trademarks of their respective companies or mark holders.

Copyright © 2016 by Super Micro Computer, Inc.
All rights reserved.

Printed in the United States of America

Preface

About This Manual

This manual is written for professional system integrators and PC technicians. It provides information for the installation and use of the SuperServer 5018A-LTN4. Installation and maintenance should be performed by experienced technicians only.

The SuperServer 5018A-LTN4 is a compact server based on the SC504-203B rackmountable chassis and the A1SAi-2750F single processor motherboard.

Manual Organization

Chapter 1: Introduction

The first chapter provides a checklist of the main components included with the server system and describes the main features of the A1SRi-2358F motherboard and the SC504-203B chassis.

Chapter 2: Server Installation

This chapter describes the steps necessary to install the SuperServer 5018A-LTN4 into a rack and check out the server configuration prior to powering up the system. If your server was ordered without processor and memory components, this chapter will refer you to the appropriate sections of the manual for their installation.

Chapter 3: Standardized Warning Statements

Refer here for details on the system interface, which includes the functions and information provided by the control panel on the chassis as well as other LEDs located throughout the system.

Chapter 4: Standardized Warning Statements

You should thoroughly familiarize yourself with this chapter for a general overview of safety precautions that should be followed when installing and servicing the SuperServer 5018A-LTN4.

Chapter 5: Advanced Motherboard Setup

Chapter 5 provides detailed information on the A1SRi-2358F motherboard, including the locations and functions of connections, headers and jumpers. Refer to this chapter when adding or removing processors or main memory and when reconfiguring the motherboard.

Chapter 6: Advanced Chassis Setup

Refer to Chapter 6 for detailed information on the SC504-203B server chassis. You should follow the procedures given in this chapter when installing, removing or reconfiguring SAS/SATA or peripheral drives and when replacing system power supply units and cooling fans.

Chapter 7: BIOS

The BIOS chapter includes an introduction to BIOS and provides detailed information on running the CMOS Setup Utility.

Appendix A: BIOS Error Beep Codes

Appendix B: System Specifications

Notes

Table of Contents

Chapter 1 Introduction

1-1	Overview	1-1
1-2	Motherboard Features.....	1-2
	Processors	1-2
	Memory	1-2
	Serial ATA.....	1-2
	I/O Ports.....	1-2
	Expansion Slot.....	1-2
	LAN Ports.....	1-2
1-3	Server Chassis Features	1-3
	System Power.....	1-3
	Hard Drive Subsystem.....	1-3
	Front Control Panel.....	1-3
1-4	Contacting Supermicro.....	1-5

Chapter 2 Server Installation

2-1	Overview	2-1
2-2	Unpacking the System.....	2-1
2-3	Preparing for Setup.....	2-1
	Choosing a Setup Location.....	2-2
2-4	Warnings and Precautions	2-2
	Rack Precautions	2-2
	Server Precautions.....	2-2
	Rack Mounting Considerations	2-3
	Ambient Operating Temperature	2-3
	Reduced Airflow	2-3
	Mechanical Loading	2-3
	Circuit Overloading.....	2-3
	Reliable Ground	2-3
2-5	Installing the System into a Rack	2-4
	Installing the Chassis into a Standard Rack.....	2-4
	Telco Rack.....	2-5
	Installing the Chassis into a Telco Rack.....	2-6

Chapter 3 System Interface

3-1	Overview	3-1
3-2	Control Panel Buttons	3-1
	Reset.....	3-1
	Power.....	3-1

3-3	Control Panel LEDs	3-2
	Power Fail	3-2
	Information LED	3-2
	NIC1	3-2
	NIC2	3-3
	HDD.....	3-3
	Power	3-3

Chapter 4 Standardized Warning Statements for AC Systems

4-1	About Standardized Warning Statements.....	4-1
	Warning Definition	4-1
	Installation Instructions.....	4-4
	Circuit Breaker	4-5
	Power Disconnection Warning	4-6
	Equipment Installation.....	4-8
	Restricted Area.....	4-9
	Battery Handling.....	4-10
	Redundant Power Supplies	4-12
	Backplane Voltage	4-13
	Comply with Local and National Electrical Codes	4-14
	Product Disposal	4-15
	Hot Swap Fan Warning.....	4-16
	Power Cable and AC Adapter	4-18

Chapter 5 Advanced Motherboard Setup

5-1	Handling the Motherboard	5-1
	Precautions	5-1
	Unpacking	5-1
5-2	Connecting Cables.....	5-2
	Connecting Data Cables	5-2
	Connecting Power Cables	5-2
	Connecting the Control Panel.....	5-2
5-3	I/O Ports.....	5-3
5-4	Memory Support.....	5-4
	Memory Population Guidelines	5-4
	Installing SODIMM Memory Modules	5-5
5-5	Expansion Cards.....	5-5
5-6	Motherboard Details.....	5-6
	A1SRi-2358F Motherboard Quick Reference	5-7

5-7	Connector Definitions	5-9
	Control Panel Connectors	5-10
	Input/Output Connectors	5-12
	Other Connectors	5-13
5-8	Jumper Settings	5-16
5-9	Onboard Indicators	5-18
5-10	SATA Ports	5-19
5-11	Installing Software	5-20
	SuperDoctor® 5	5-21
5-12	Serverboard Battery	5-22

Chapter 6 Advanced Chassis Setup

6-1	Static-Sensitive Devices	6-1
	Precautions	6-1
	Unpacking	6-1
6-2	Control Panel	6-2
6-3	Removing the Chassis Cover	6-3
6-4	System Fans	6-4
6-5	Installing Hard Drives	6-4
	Hard Drive Configuration Options	6-6
6-6	Installing an Expansion Card	6-7
6-7	Power Supply	6-9
	Replacing the Power Supply	6-9

Chapter 7 BIOS

7-1	Introduction	7-1
	Starting BIOS Setup Utility	7-1
	How To Change the Configuration Data	7-1
	How to Start the Setup Utility	7-2
7-2	Main Setup	7-2
7-3	Advanced Setup Configurations	7-4
7-4	Event Logs	7-27
7-5	IPMI	7-29
7-6	Security Settings	7-31
7-7	Boot Settings	7-34
7-8	Save & Exit	7-35

Appendix A BIOS POST Error Codes

Appendix B System Specifications

Chapter 1

Introduction

1-1 Overview

The SuperServer 5018A-LTN4 is a compact server comprised of two main subsystems: the SC504-203B 1U chassis and the A1SRi-2358F single processor motherboard. Please refer to our web site for information on operating systems that have been certified for use with the system (www.supermicro.com).

In addition to the motherboard and chassis, various hardware components have been included with the 5018A-LTN4, as listed below:

- One riser card bracket for slot 7 (MCP-120-00063-0N)
- One 4-cm PWM fan (FAN-0100L4)
- One riser card (RSC-RR1U-E8)
- Optional: one tray for 4-cm fan (MCP-320-81302-0B)

Note: For your system to work properly, please follow the links below to download all necessary drivers/utilities and the user's manual for your server.

- Supermicro product manuals: <http://www.supermicro.com/support/manuals/>
- Product drivers and utilities: <ftp://ftp.supermicro.com>
- Product safety info: http://super-dev/about/policies/safety_information.cfm
- If you have any questions, please contact our support team at: support@supermicro.com

1-2 Motherboard Features

At the heart of the SuperServer A1SRi-2358F lies the A1SRi-2358F, a single processor motherboard based on the Intel Atom System on a Chip (see Figure 1-1 for a block diagram).

Processors

The motherboard supports a single Intel Atom C2758 Tri-Gate, SoC FCBGA 1283 socket, 20W 8-Core processor.

Memory

The motherboard can support up to 64 GB of unbuffered ECC UDIMM DDR3 SDRAM memory at 1600/1333 MHz speeds, in eight (8) slots, and in either 2, 4, 8, or 16 GB size SODIMMs.

Serial ATA

The motherboard offers two SATA3 (6Gbps) ports and four SATA2 (3Gbps) ports.

I/O Ports

The motherboard includes four LAN ports, an IPMI port, two USB 3.0 rear ports, two USB 2.0 rear ports, two USB 3.0 (one Type A, one header), one SATA DOM power connector, one rear COM port, one front accessible COM port header, and one VGA port.

Expansion Slot

The server supports one low profile PCI Express 2.0 x8 card.

LAN Ports

The system features four GbE LAN ports and one IPMI LAN connector.

1-3 Server Chassis Features

The SC504-203B is a mini-ITX form factor chassis designed to be used in a 1U rackmount configuration. The following is a general outline of the main features of the SC504-203B server chassis.

System Power

The SC504-203B features a single 200 Watt power supply. Power must be removed from the system and the AC power cord removed when replacing. See Chapter 6 for details.

Hard Drive Subsystem

Either four (4) 3.5" hot-swap drive bays or two (2) 2.5" fixed internal drives (with a 2.5" HDD bracket) are supported by the system. These are not hot-swap drives.

Front Control Panel

The control panel on the SC504-203B provides you with system monitoring and control. LEDs indicate system power, HDD activity, network activity, system information and power supply failure. A main power button and a system reset button are also included.

Figure 1-1. System Block Diagram

Note: This is a general block diagram. Please see Chapter 5 for details.

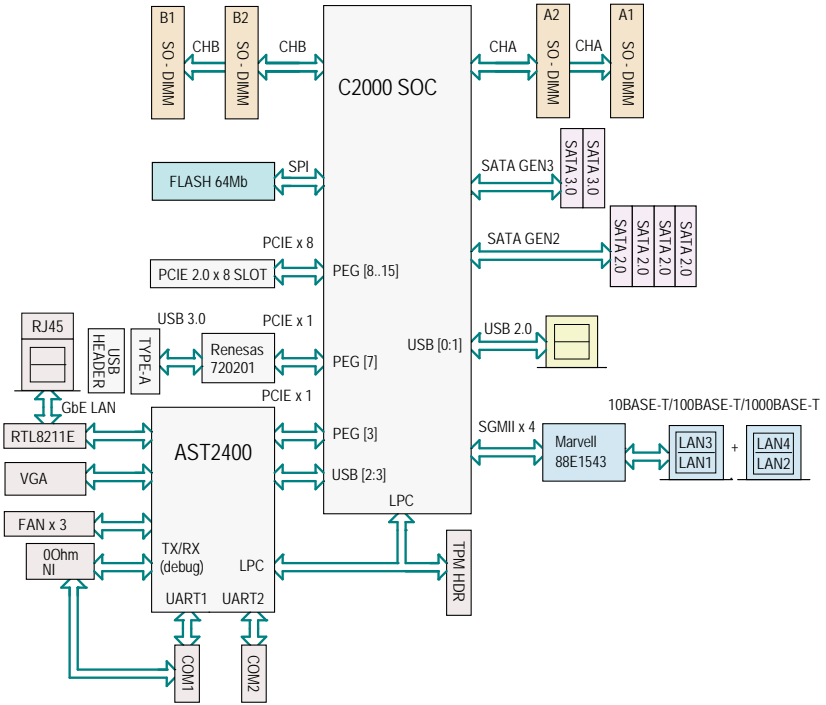

1-4 Contacting Supermicro

Headquarters

Address: Super Micro Computer, Inc.
980 Rock Ave.
San Jose, CA 95131 U.S.A.

Tel: +1 (408) 503-8000

Fax: +1 (408) 503-8008

Email: marketing@supermicro.com (General Information)
support@supermicro.com (Technical Support)

Web Site: www.supermicro.com

Europe

Address: Super Micro Computer B.V.
Het Sterrenbeeld 28, 5215 ML
's-Hertogenbosch, The Netherlands

Tel: +31 (0) 73-6400390

Fax: +31 (0) 73-6416525

Email: sales@supermicro.nl (General Information)
support@supermicro.nl (Technical Support)
rma@supermicro.nl (Customer Support)

Web Site: www.supermicro.nl

Asia-Pacific

Address: Super Micro Computer, Inc.
3F, No. 150, Jian 1st Rd.
Zhonghe Dist., New Taipei City 235
Taiwan (R.O.C)

Tel: +886-(2) 8226-3990

Fax: +886-(2) 8226-3992

Email: support@supermicro.com.tw

Web Site: www.supermicro.com.tw

Notes

Chapter 2

Server Installation

2-1 Overview

This chapter provides a quick setup checklist to get your SuperServer 5018A-LTN4 up and running. Following these steps in the order given should enable you to have the system operational within a minimum amount of time. This quick setup assumes that your system has come to you with the processors and memory preinstalled. If your system is not already fully integrated with a serverboard, processors, system memory etc., then please turn to the chapter or section noted in each step for details on installing specific components.

2-2 Unpacking the System

You should inspect the box the SuperServer 5018A-LTN4 was shipped in and note if it was damaged in any way. If the server itself shows damage you should file a damage claim with the carrier who delivered it.

Decide on a suitable location for the rack unit that will hold the SuperServer 5018A-LTN4. It should be situated in a clean, dust-free area that is well ventilated. Avoid areas where heat, electrical noise and electromagnetic fields are generated. You will also need it placed near a grounded power outlet. Read the Rack and Server Precautions in the next section.

2-3 Preparing for Setup

The box the SuperServer 5018A-LTN4 was shipped in should include two sets of rail assemblies, two rail mounting brackets and the mounting screws you will need to install the system into the rack. Follow the steps in the order given to complete the installation process in a minimum amount of time. Please read this section in its entirety before you begin the installation procedure outlined in the sections that follow.

Choosing a Setup Location

- Leave enough clearance in front of the rack to enable you to open the front door completely (~25 inches) and approximately 30 inches of clearance in the back of the rack to allow for sufficient airflow and ease in servicing.
- This product is for installation only in a Restricted Access Location (dedicated equipment rooms, service closets and the like).
- This product is not suitable for use with visual display work place devices according to §2 of the the German Ordinance for Work with Visual Display Units.

2-4 Warnings and Precautions

Rack Precautions

- Ensure that the leveling jacks on the bottom of the rack are fully extended to the floor with the full weight of the rack resting on them.
- In single rack installation, stabilizers should be attached to the rack. In multiple rack installations, the racks should be coupled together.
- Always make sure the rack is stable before extending a component from the rack.
- You should extend only one component at a time - extending two or more simultaneously may cause the rack to become unstable.

Server Precautions

- Review the electrical and general safety precautions in Chapter 4.
- Determine the placement of each component in the rack *before* you install the rails.
- Install the heaviest server components on the bottom of the rack first, and then work up.
- Use a regulating uninterruptible power supply (UPS) to protect the server from power surges, voltage spikes and to keep your system operating in case of a power failure.
- Allow any hot plug drives and power supply modules to cool before touching them.
- Always keep the rack's front door and all panels and components on the servers closed when not servicing to maintain proper cooling.

Rack Mounting Considerations

Ambient Operating Temperature

If installed in a closed or multi-unit rack assembly, the ambient operating temperature of the rack environment may be greater than the ambient temperature of the room. Therefore, consideration should be given to installing the equipment in an environment compatible with the manufacturer's maximum rated ambient temperature (Tmra).

Reduced Airflow

Equipment should be mounted into a rack so that the amount of airflow required for safe operation is not compromised.

Mechanical Loading

Equipment should be mounted into a rack so that a hazardous condition does not arise due to uneven mechanical loading.

Circuit Overloading

Consideration should be given to the connection of the equipment to the power supply circuitry and the effect that any possible overloading of circuits might have on overcurrent protection and power supply wiring. Appropriate consideration of equipment nameplate ratings should be used when addressing this concern.

Reliable Ground

A reliable ground must be maintained at all times. To ensure this, the rack itself should be grounded. Particular attention should be given to power supply connections other than the direct connections to the branch circuit (i.e. the use of power strips, etc.).



Warning! To prevent bodily injury when mounting or servicing this unit in a rack, you must take special precautions to ensure that the system remains stable. The following guidelines are provided to ensure your safety:

- This unit should be mounted at the bottom of the rack if it is the only unit in the rack.
- When mounting this unit in a partially filled rack, load the rack from the bottom to the top with the heaviest component at the bottom of the rack.
- If the rack is provided with stabilizing devices, install the stabilizers before mounting or servicing the unit in the rack.

2-5 Installing the System into a Rack

This section provides information on installing the SC504 chassis into a rack unit. There are a variety of rack units on the market, which may mean the assembly procedure will differ slightly. You should also refer to the installation instructions that came with the rack unit you are using.

Installing the Chassis into a Standard Rack

1. Confirm that chassis includes the four mounting screws required to mount the chassis into a rack
2. Align the thru holes of the chassis with the thru holes of the rack.
3. Insert the mounting screws into the thru holes in the front of the chassis and through the thru holes in the rack and secure.

Figure 2-1. Installing the Chassis into a Rack

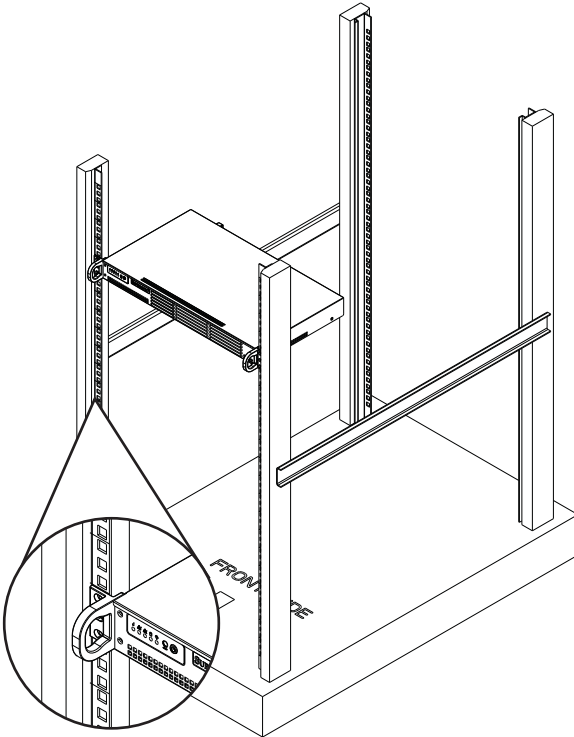

Stability hazard. The rack stabilizing mechanism must be in place, or the rack must be bolted to the floor before you slide the unit out for servicing. Failure to stabilize the rack can cause the rack to tip over.

Telco Rack

The SC504 supports Telco Rack installation. The compact design of the SC504 chassis allows it to be installed into a Telco rack without the use of rails.

Figure 2-2. Installing the Chassis into a Telco Rack

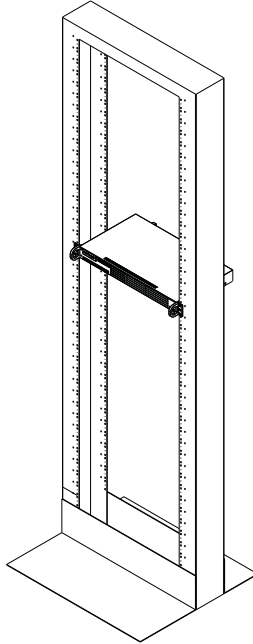

Note: the figures are for illustrative purposes only. Always install servers to the bottom of a rack first.



Warning: do not pick up the server with the front handles. They are designed to pull the system from a rack only.

Installing the Chassis into a Telco Rack

1. To install the chassis into a Telco style two-post rack, use two L-shaped brackets on either side of the chassis (four total).
2. First, determine how far follow the server will extend out the front of the rack. Larger chassis should be positioned to balance the weight between front and back.
3. If a bezel is included on your chassis, remove it. Then attach the two front brackets to each side of the chassis, then the two rear brackets positioned with just enough space to accommodate the width of the Telco rack.
4. Finish by sliding the chassis into the rack and tightening the brackets to the rack.

Chapter 3

System Interface

3-1 Overview

There are several LEDs on the control panel as well as others on the drive carriers to keep you constantly informed of the overall status of the system and the activity and health of specific components. There are also two buttons on the chassis control panel.

3-2 Control Panel Buttons

There are two buttons located on the front of the chassis: a reset button and a power on/off button.

RESET



Reset

Use the reset button to reboot the system.



Power

This is the main power button, which is used to apply or turn off the main system power. Turning off system power with this button removes the main power but keeps standby power supplied to the system.

3-3 Control Panel LEDs

The control panel located on the front of the chassis has six LEDs. These LEDs provide you with critical information related to different parts of the system. This section explains what each LED indicates when illuminated and any corrective action you may need to take.



Power Fail

Indicates a power supply module has failed. The second power supply module will take the load and keep the system running but the failed module will need to be replaced. Refer to Chapter 6 for details on replacing the power supply. This LED should be off when the system is operating normally.



Information LED

The Information LED doubles as a unit indicator and as a warning LED. See the table below for details.

Information LED	
Status	Description
Continuously on and red	An overheat condition has occurred. (This may be caused by cable congestion.)
Blinking red (1Hz)	Fan failure, check for an inoperative fan.
Blinking red (0.25Hz)	Power failure, check for a non-operational power supply.
Solid blue	Local UID has been activated. Use this function to locate the server in a rack mount environment.
Blinking blue (300 m/s)	Remote UID is on. Use this function to identify the server from a remote location.



NIC1

Indicates network activity on the LAN1 port when flashing.



NIC2

Indicates network activity on the LAN2 port when flashing.



HDD

On the SuperServer 5018A-LTN4, this LED indicates SATA drive activity when flashing.



Power

Indicates power is being supplied to the system's power supply units. This LED should normally be illuminated when the system is operating.

Notes

Chapter 4

Standardized Warning Statements for AC Systems

4-1 About Standardized Warning Statements

The following statements are industry standard warnings, provided to warn the user of situations which have the potential for bodily injury. Should you have questions or experience difficulty, contact Supermicro's Technical Support department for assistance. Only certified technicians should attempt to install or configure components.

Read this appendix in its entirety before installing or configuring components in the Supermicro chassis.

These warnings may also be found on our web site at http://www.supermicro.com/about/policies/safety_information.cfm.

Warning Definition



Warning!

This warning symbol means danger. You are in a situation that could cause bodily injury. Before you work on any equipment, be aware of the hazards involved with electrical circuitry and be familiar with standard practices for preventing accidents.

警告の定義

この警告サインは危険を意味します。

人身事故につながる可能性がありますので、いずれの機器でも動作させる前に、電気回路に含まれる危険性に注意して、標準的な事故防止策に精通して下さい。

此警告符号代表危險。

您正處於可能受到嚴重傷害的工作環境中。在您使用設備開始工作之前，必須充分意識到觸電的危險，並熟練掌握防止事故發生的標準工作程序。請根據每項警告結尾的聲明號碼找到此設備的安全性警告說明的翻譯文本。

此警告符號代表危險。

您正處於可能身體可能會受損傷的工作環境中。在您使用任何設備之前，請注意觸電的危險，並且要熟悉預防事故發生的標準工作程序。請依照每一注意事項後的號碼找到相關的翻譯說明內容。

Warnung

WICHTIGE SICHERHEITSHINWEISE

Dieses Warnsymbol bedeutet Gefahr. Sie befinden sich in einer Situation, die zu Verletzungen führen kann. Machen Sie sich vor der Arbeit mit Geräten mit den Gefahren elektrischer Schaltungen und den üblichen Verfahren zur Vorbeugung vor Unfällen vertraut. Suchen Sie mit der am Ende jeder Warnung angegebenen Anweisungsnummer nach der jeweiligen Übersetzung in den übersetzten Sicherheitshinweisen, die zusammen mit diesem Gerät ausgeliefert wurden.

BEWAHREN SIE DIESE HINWEISE GUT AUF.

INSTRUCCIONES IMPORTANTES DE SEGURIDAD

Este símbolo de aviso indica peligro. Existe riesgo para su integridad física. Antes de manipular cualquier equipo, considere los riesgos de la corriente eléctrica y familiarícese con los procedimientos estándar de prevención de accidentes. Al final de cada advertencia encontrará el número que le ayudará a encontrar el texto traducido en el apartado de traducciones que acompaña a este dispositivo.

GUARDE ESTAS INSTRUCCIONES.

IMPORTANTES INFORMATIONS DE SÉCURITÉ

Ce symbole d'avertissement indique un danger. Vous vous trouvez dans une situation pouvant entraîner des blessures ou des dommages corporels. Avant de travailler sur un équipement, soyez conscient des dangers liés aux circuits électriques et familiarisez-vous avec les procédures couramment utilisées pour éviter les accidents. Pour prendre connaissance des traductions des avertissements figurant dans les consignes de sécurité traduites qui accompagnent cet appareil, référez-vous au numéro de l'instruction situé à la fin de chaque avertissement.

CONSERVEZ CES INFORMATIONS.

תקנון הצהרות אזהרה

הצהרות הבאות הן אזהרות על פי תקני התעשייה, על מנת להזהיר את המשתמש מפני חבלה פיזית אפשרית. במידה ויש שאלות או היתקלות בבעיה כלשהי, יש ליצור קשר עם מחלקת תמיכה טכנית של סופרמיקרו. טכנאים מוסמכים בלבד רשאים להתקין או להגדיר את הרכיבים.

יש לקרוא את הנספח במלואו לפני התקנת או הגדרת הרכיבים במארזי סופרמיקרו.

تحذير! هذا الرمز يعني خطر انك في حالة يمكن أن تتسبب في اصابة جسدية .
قبل أن تعمل على أي معدات، كن على علم بالمخاطر الناجمة عن الدوائر
الكهربائية
وكن على دراية بالممارسات الوقائية لمنع وقوع أي حوادث
استخدم رقم البيان المنصوص في نهاية كل تحذير للعثور ترجمتها

안전을 위한 주의사항

경고!

이 경고 기호는 위험이 있음을 알려 줍니다. 작업자의 신체에 부상을 야기 할 수 있는 상태에 있게 됩니다. 모든 장비에 대한 작업을 수행하기 전에 전기회로와 관련된 위험요소들을 확인하시고 사전에 사고를 방지할 수 있도록 표준 작업절차를 준수해 주시기 바랍니다.

해당 번역문을 찾기 위해 각 경고의 마지막 부분에 제공된 경고문 번호를 참조하십시오

BELANGRIJKE VEILIGHEIDSINSTRUCTIES

Dit waarschuwings symbool betekent gevaar. U verkeert in een situatie die lichamelijk letsel kan veroorzaken. Voordat u aan enige apparatuur gaat werken, dient u zich bewust te zijn van de bij een elektrische installatie betrokken risico's en dient u op de hoogte te zijn van de standaard procedures om ongelukken te voorkomen. Gebruik de nummers aan het eind van elke waarschuwing om deze te herleiden naar de desbetreffende locatie.

BEWAAR DEZE INSTRUCTIES

Installation Instructions



Warning!

Read the installation instructions before connecting the system to the power source.

設置手順書

システムを電源に接続する前に、設置手順書をお読み下さい。

警告

将此系统连接电源前，请先阅读安装说明。

警告

將系統與電源連接前，請先閱讀安裝說明。

Warnung

Vor dem Anschließen des Systems an die Stromquelle die Installationsanweisungen lesen.

¡Advertencia!

Lea las instrucciones de instalación antes de conectar el sistema a la red de alimentación.

Attention

Avant de brancher le système sur la source d'alimentation, consulter les directives d'installation.

יש לקרוא את הוראות התקנה לפני חיבור המערכת למקור מתח.

اقر إرشادات التركيب قبل توصيل النظام إلى مصدر للطاقة

시스템을 전원에 연결하기 전에 설치 안내를 읽어주십시오.

Waarschuwing

Raadpleeg de installatie-instructies voordat u het systeem op de voedingsbron aansluit.

Circuit Breaker



Warning!

This product relies on the building's installation for short-circuit (overcurrent) protection. Ensure that the protective device is rated not greater than: 250 V, 20 A.

サーキット・ブレーカー

この製品は、短絡(過電流)保護装置がある建物での設置を前提としています。
保護装置の定格が250 V、20 Aを超えないことを確認下さい。

警告

此产品的短路(过载电流)保护由建筑物的供电系统提供,确保短路保护设备的额定电流不大于250V,20A。

警告

此產品的短路(過載電流)保護由建築物的供電系統提供,確保短路保護設備的額定電流不大於250V,20A。

Warnung

Dieses Produkt ist darauf angewiesen, dass im Gebäude ein Kurzschluss- bzw. Überstromschutz installiert ist. Stellen Sie sicher, dass der Nennwert der Schutzvorrichtung nicht mehr als: 250 V, 20 A beträgt.

¡Advertencia!

Este equipo utiliza el sistema de protección contra cortocircuitos (o sobrecorrientes) del edificio. Asegúrese de que el dispositivo de protección no sea superior a: 250 V, 20 A.

Attention

Pour ce qui est de la protection contre les courts-circuits (surtension), ce produit dépend de l'installation électrique du local. Vérifiez que le courant nominal du dispositif de protection n'est pas supérieur à :250 V, 20 A.

מוצר זה מסתמך על הגנה המותקנת במבנים למניעת קצר חשמלי. יש לוודא כי
המכשיר המגן מפני הקצר החשמלי הוא לא יותר מ-250 V, 20 A

هذا المنتج يعتمد على معدات الحماية من الدوائر القصيرة التي تم تثبيتها في
المبنى

تأكد من أن تقييم الجهاز الوقائي ليس أكثر من: 20A, 250V

경고!

이 제품은 전원의 단락(과전류)방지에 대해서 전적으로 건물의 관련 설비에 의존합니다. 보호장치의 정격이 반드시 250V(볼트), 20A(암페어)를 초과하지 않도록 해야 합니다.

Waarschuwing

Dit product is afhankelijk van de kortsluitbeveiliging (overspanning) van uw elektrische installatie. Controleer of het beveiligde apparaat niet groter gedimensioneerd is dan 220V, 20A.

Power Disconnection Warning



Warning!

The system must be disconnected from all sources of power and the power cord removed from the power supply module(s) before accessing the chassis interior to install or remove system components.

電源切斷の警告

システムコンポーネントの取り付けまたは取り外しのために、シャーシー内部にアクセスするには、

システムの電源はすべてのソースから切斷され、電源コードは電源モジュールから取り外す必要があります。

警告

在你打开机箱并安装或移除内部器件前,必须将系统完全断电,并移除电源线。

警告

在您打開機殼安裝或移除內部元件前,必須將系統完全斷電,並移除電源線。

Warnung

Das System muss von allen Quellen der Energie und vom Netzanschlusskabel getrennt sein, das von den Spg.Versorgungsteilmodulen entfernt wird, bevor es auf den Chassisinnenraum zurückgreift, um Systemsbestandteile anzubringen oder zu entfernen.

¡Advertencia!

El sistema debe ser disconnected de todas las fuentes de energía y del cable eléctrico quitado de los módulos de fuente de alimentación antes de tener acceso el interior del chasis para instalar o para quitar componentes de sistema.

Attention

Le système doit être débranché de toutes les sources de puissance ainsi que de son cordon d'alimentation secteur avant d'accéder à l'intérieur du chasis pour installer ou enlever des composants de système.

אזהרה מפני ניתוק חשמלי

אזהרה!

יש לנתק את המערכת מכל מקורות החשמל ויש להסיר את כבל החשמלי מהספק לפני גישה לחלק הפנימי של המארז לצורך התקנת או הסרת רכיבים.

يجب فصل النظام من جميع مصادر الطاقة وإزالة سلك الكهرباء من وحدة امداد الطاقة قبل الوصول إلى المناطق الداخلية للهيكल لتثبيت أو إزالة مكونات الجهاز

경고!

시스템에 부품들을 장착하거나 제거하기 위해서는 새시 내부에 접근하기 전에 반드시 전원 공급장치로부터 연결되어있는 모든 전원과 전기코드를 분리해주어야 합니다.

Waarschuwing

Voordat u toegang neemt tot het binnenwerk van de behuizing voor het installeren of verwijderen van systeem onderdelen, dient u alle spanningsbronnen en alle stroomkabels aangesloten op de voeding(en) van de behuizing te verwijderen

Equipment Installation



Warning!

Only trained and qualified personnel should be allowed to install, replace, or service this equipment.

機器の設置

トレーニングを受け認定された人だけがこの装置の設置、交換、またはサービスを許可されています。

警告

只有经过培训且具有资格的人员才能进行此设备的安装、更换和维修。

警告

只有經過受訓且具資格人員才可安裝、更換與維修此設備。

Warnung

Das Installieren, Ersetzen oder Bedienen dieser Ausrüstung sollte nur geschultem, qualifiziertem Personal gestattet werden.

¡Advertencia!

Solamente el personal calificado debe instalar, reemplazar o utilizar este equipo.

Attention

Il est vivement recommandé de confier l'installation, le remplacement et la maintenance de ces équipements à des personnels qualifiés et expérimentés.

אזהרה!

צוות מוסמך בלבד רשאי להתקין, להחליף את הציוד או לתת שירות עבור הציוד.

يجب أن يسمح فقط للموظفين المؤهلين والمدربين لتثبيت واستبدال أو خدمة هذا الجهاز

경고!

훈련을 받고 공인된 기술자만이 이 장비의 설치, 교체 또는 서비스를 수행할 수 있습니다.

Waarschuwing

Deze apparatuur mag alleen worden geïnstalleerd, vervangen of hersteld door geschoold en gekwalificeerd personeel.

Restricted Area



Warning!

This unit is intended for installation in restricted access areas. A restricted access area can be accessed only through the use of a special tool, lock and key, or other means of security. (This warning does not apply to workstations).

アクセス制限区域

このユニットは、アクセス制限区域に設置されることを想定しています。

アクセス制限区域は、特別なツール、鍵と錠前、その他のセキュリティの手段を用いてのみ出入りが可能です。

警告

此部件应安装在限制进出的场所，限制进出的场所指只能通过使用特殊工具、锁和钥匙或其它安全手段进出的场所。

警告

此裝置僅限安裝於進出管制區域，進出管制區域係指僅能以特殊工具、鎖頭及鑰匙或其他安全方式才能進入的區域。

Warnung

Diese Einheit ist zur Installation in Bereichen mit beschränktem Zutritt vorgesehen. Der Zutritt zu derartigen Bereichen ist nur mit einem Spezialwerkzeug, Schloss und Schlüssel oder einer sonstigen Sicherheitsvorkehrung möglich.

¡Advertencia!

Esta unidad ha sido diseñada para instalación en áreas de acceso restringido. Sólo puede obtenerse acceso a una de estas áreas mediante la utilización de una herramienta especial, cerradura con llave u otro medio de seguridad.

Attention

Cet appareil doit être installée dans des zones d'accès réservés. L'accès à une zone d'accès réservé n'est possible qu'en utilisant un outil spécial, un mécanisme de verrouillage et une clé, ou tout autre moyen de sécurité.

אזור עם גישה מוגבלת

אזהרה!

יש להתקין את היחידה באזורים שיש בהם הגבלת גישה. הגישה ניתנת בעזרת כלי אבטחה בלבד (מפתח, מנעול וכד').

تم تخصيص هذه الوحدة لتركيبها في مناطق محظورة .
يمكن الوصول إلى منطقة محظورة فقط من خلال استخدام أداة خاصة،
قفل ومفتاح أو أي وسيلة أخرى للأمان

경고!

이 장치는 접근이 제한된 구역에 설치하도록 되어있습니다. 특수도구, 잠금 장치 및 키, 또는 기타 보안 수단을 통해서만 접근 제한 구역에 들어갈 수 있습니다.

Waarschuwing

Dit apparaat is bedoeld voor installatie in gebieden met een beperkte toegang. Toegang tot dergelijke gebieden kunnen alleen verkregen worden door gebruik te maken van speciaal gereedschap, slot en sleutel of andere veiligheidsmaatregelen.

Battery Handling



Warning!

There is the danger of explosion if the battery is replaced incorrectly. Replace the battery only with the same or equivalent type recommended by the manufacturer. Dispose of used batteries according to the manufacturer's instructions

電池の取り扱い

電池交換が正しく行われなかった場合、破裂の危険性があります。交換する電池はメーカーが推奨する型、または同等のものを使用下さい。使用済電池は製造元の指示に従って処分して下さい。

警告

电池更换不当会有爆炸危险。请只使用同类电池或制造商推荐的功能相当的电池更换原有电池。请按制造商的说明处理废旧电池。

警告

電池更換不當會有爆炸危險。請使用製造商建議之相同或功能相當的電池更換原有電池。請按照製造商的說明指示處理廢棄舊電池。

Warnung

Bei Einsetzen einer falschen Batterie besteht Explosionsgefahr. Ersetzen Sie die Batterie nur durch den gleichen oder vom Hersteller empfohlenen Batterietyp. Entsorgen Sie die benutzten Batterien nach den Anweisungen des Herstellers.

Attention

Danger d'explosion si la pile n'est pas remplacée correctement. Ne la remplacer que par une pile de type semblable ou équivalent, recommandée par le fabricant. Jeter les piles usagées conformément aux instructions du fabricant.

¡Advertencia!

Existe peligro de explosión si la batería se reemplaza de manera incorrecta. Reemplazar la batería exclusivamente con el mismo tipo o el equivalente recomendado por el fabricante. Desechar las baterías gastadas según las instrucciones del fabricante.

אזהרה!

קיימת סכנת פיצוץ של הסוללה במידה והוחלפה בדרך לא תקינה. יש להחליף את הסוללה בסוג התואם מחברת יצרן מומלצת.

סילוק הסוללות המשומשות יש לבצע לפי הוראות היצרן.

هناك خطر من انفجار في حالة استبدال البطارية بطريقة غير صحيحة فعليك استبدال البطارية فقط بنفس النوع أو ما يعادلها كما أوصت به الشركة المصنعة تخلص من البطاريات المستعملة وفقا لتعليمات الشركة الصانعة

경고!

배터리가 올바르게 교체되지 않으면 폭발의 위험이 있습니다. 기존 배터리와 동일하거나 제조사에서 권장하는 동등한 종류의 배터리로만 교체해야 합니다. 제조사의 안내에 따라 사용된 배터리를 처리하여 주십시오.

Waarschuwing

Er is ontploffingsgevaar indien de batterij verkeerd vervangen wordt. Vervang de batterij slechts met hetzelfde of een equivalent type die door de fabrikant aanbevolen wordt. Gebruikte batterijen dienen overeenkomstig fabrieksvoorschriften afgevoerd te worden.

Redundant Power Supplies



Warning!

This unit might have more than one power supply connection. All connections must be removed to de-energize the unit.

冗長電源装置

このユニットは複数の電源装置が接続されている場合があります。
ユニットの電源を切るためには、すべての接続を取り外さなければなりません。

警告

此部件连接的电源可能不止一个，必须将所有电源断开才能停止给该部件供电。

警告

此装置连接的电源可能不只一个，必须切断所有电源才能停止对该装置的供电。

Warnung

Dieses Gerät kann mehr als eine Stromzufuhr haben. Um sicherzustellen, dass der Einheit kein Strom zugeführt wird, müssen alle Verbindungen entfernt werden.

¡Advertencia!

Puede que esta unidad tenga más de una conexión para fuentes de alimentación. Para cortar por completo el suministro de energía, deben desconectarse todas las conexiones.

Attention

Cette unité peut avoir plus d'une connexion d'alimentation. Pour supprimer toute tension et tout courant électrique de l'unité, toutes les connexions d'alimentation doivent être débranchées.

אם קיים יותר מספק אחד

אזהרה!

ליחידה יש יותר מחיבור אחד של ספק. יש להסיר את כל החיבורים על מנת לרוקן את היחידה.

قد يكون لهذا الجهاز عدة اتصالات بوحدات امداد الطاقة.
يجب إزالة كافة الاتصالات لعزل الوحدة عن الكهرباء

경고!

이 장치에는 한 개 이상의 전원 공급 단자가 연결되어 있을 수 있습니다. 이 장치에 전원을 차단하기 위해서는 모든 연결 단자를 제거해야만 합니다.

Waarschuwing

Deze eenheid kan meer dan één stroomtoevoeraansluiting bevatten. Alle aansluitingen dienen verwijderd te worden om het apparaat stroomloos te maken.

Backplane Voltage



Warning!

Hazardous voltage or energy is present on the backplane when the system is operating. Use caution when servicing.

バックプレーンの電圧

システムの稼働中は危険な電圧または電力が、バックプレーン上にかかっています。
修理するには注意ください。

警告

当系统正在进行时，背板上有很危险的电压或能量，进行维修时务必小心。

警告

當系統正在進行時，背板上有很危險的電壓或能量，進行維修時務必小心。

Warnung

Wenn das System in Betrieb ist, treten auf der Rückwandplatine gefährliche Spannungen oder Energien auf. Vorsicht bei der Wartung.

¡Advertencia!

Cuando el sistema está en funcionamiento, el voltaje del plano trasero es peligroso. Tenga cuidado cuando lo revise.

Attention

Lorsque le système est en fonctionnement, des tensions électriques circulent sur le fond de panier. Prendre des précautions lors de la maintenance.

מתח בפנל האחורי

אזהרה!
קיימת סכנת מתח בפנל האחורי בזמן תפעול המערכת. יש להיזהר במהלך העבודה.

هناك خطر من التيار الكهربائي أو الطاقة الموجودة على اللوحة عندما يكون النظام يعمل كن حذرا عند خدمة هذا الجهاز

경고!

시스템이 동작 중일 때 후면판 (Backplane)에는 위험한 전압이나 에너지가 발생합니다. 서비스 작업 시 주의하십시오.

Waarschuwing

Een gevaarlijke spanning of energie is aanwezig op de backplane wanneer het systeem in gebruik is. Voorzichtigheid is geboden tijdens het onderhoud.

Comply with Local and National Electrical Codes



Warning!

Installation of the equipment must comply with local and national electrical codes.

地方および国の電気規格に準拠

機器の取り付けはその地方および国の電気規格に準拠する必要があります。

警告

设备安装必须符合本地与本国电气法规。

警告

設備安裝必須符合本地與本國電氣法規。

Warnung

Die Installation der Geräte muss den Sicherheitsstandards entsprechen.

¡Advertencia!

La instalacion del equipo debe cumplir con las normas de electricidad locales y nacionales. Attention

L'équipement doit être installé conformément aux normes électriques nationales et locales.

תיאום חוקי החשמל הארצי

אזהרה!

התקנת הציוד חייבת להיות תואמת לחוקי החשמל המקומיים והארציים.

تركيب المعدات الكهربائية يجب أن يمتثل للقوانين المحلية والوطنية المتعلقة بالكهرباء

경고!

현 지역 및 국가의 전기 규정에 따라 장비를 설치해야 합니다.

Waarschuwing

Bij installatie van de apparatuur moet worden voldaan aan de lokale en nationale elektriciteitsvoorschriften.

Product Disposal



Warning!

Ultimate disposal of this product should be handled according to all national laws and regulations.

製品の廃棄

この製品を廃棄処分する場合、国の関係する全ての法律・条例に従い処理する必要があります。

警告

本产品的废弃处理应根据所有国家的法律和规章进行。

警告

本產品的廢棄處理應根據所有國家的法律和規章進行。

Warnung

Die Entsorgung dieses Produkts sollte gemäß allen Bestimmungen und Gesetzen des Landes erfolgen.

¡Advertencia!

Al deshacerse por completo de este producto debe seguir todas las leyes y reglamentos nacionales.

Attention

La mise au rebut ou le recyclage de ce produit sont généralement soumis à des lois et/ou directives de respect de l'environnement. Renseignez-vous auprès de l'organisme compétent.

סילוק המוצר

אזהרה!

סילוק סופי של מוצר זה חייב להיות בהתאם להנחיות וחוקי המדינה.

عند التخلص النهائي من هذا المنتج ينبغي التعامل معه وفقا لجميع القوانين واللوائح الوطنية

경고!

이 제품은 해당 국가의 관련 법규 및 규정에 따라 폐기되어야 합니다.

Waarschuwing

De uiteindelijke verwijdering van dit product dient te geschieden in overeenstemming met alle nationale wetten en reglementen.

Hot Swap Fan Warning



Warning!

The fans might still be turning when you remove the fan assembly from the chassis. Keep fingers, screwdrivers, and other objects away from the openings in the fan assembly's housing.

ファン・ホットスワップの警告

シャーシから冷却ファン装置を取り外した際、ファンがまだ回転している可能性があります。ファンの開口部に、指、ドライバー、およびその他のものを近づけないで下さい。

警告

当您从机架移除风扇装置，风扇可能仍在转动。小心不要将手指、螺丝起子和其他物品太靠近风扇

警告

當您從機架移除風扇裝置，風扇可能仍在轉動。小心不要將手指、螺絲起子和其他物品太靠近風扇。

Warnung

Die Lüfter drehen sich u. U. noch, wenn die Lüfterbaugruppe aus dem Chassis genommen wird. Halten Sie Finger, Schraubendreher und andere Gegenstände von den Öffnungen des Lüftergehäuses entfernt.

¡Advertencia!

Los ventiladores podran dar vuelta cuando usted quite el montaje del ventilador del chasis. Mantenga los dedos, los destornilladores y todos los objetos lejos de las aberturas del ventilador

Attention

Il est possible que les ventilateurs soient toujours en rotation lorsque vous retirerez le bloc ventilateur du châssis. Prenez garde à ce que doigts, tournevis et autres objets soient éloignés du logement du bloc ventilateur.

אזהרה!

כאשר מסירים את חלקי המאוורר מהמארז, יתכן והמאווררים עדיין עובדים. יש להרחיק למרחק בטוח את האצבעות וכלי עבודה שונים מהפתחים בתוך המאוורר

من الممكن أن المراوح لا تزال تدور عند إزالة كتلة المروحة من الهيكل يجب إبقاء الأصابع ومفكات البراغي وغيرها من الأشياء بعيدا عن الفتحات في كتلة المروحة.

경고!

새시로부터 팬 조립품을 제거할 때 팬은 여전히 회전하고 있을 수 있습니다. 팬 조립품 외관의 열려있는 부분들로부터 손가락 및 스크류드라이버, 다른 물체들이 가까이 하지 않도록 배치해 주십시오.

Waarschuwing

Het is mogelijk dat de ventilator nog draait tijdens het verwijderen van het ventilatorsamenstel uit het chassis. Houd uw vingers, schroevendraaiers en eventuele andere voorwerpen uit de buurt van de openingen in de ventilatorbehuizing.

Power Cable and AC Adapter



Warning!

When installing the product, use the provided or designated connection cables, power cables and AC adaptors. Using any other cables and adaptors could cause a malfunction or a fire. Electrical Appliance and Material Safety Law prohibits the use of UL or CSA -certified cables (that have UL/CSA shown on the code) for any other electrical devices than products designated by Supermicro only.

電源コードとACアダプター

製品を設置する場合、提供または指定された接続ケーブル、電源コードとACアダプターを使用下さい。他のケーブルやアダプタを使用すると故障や火災の原因になることがあります。電気用品安全法は、ULまたはCSA認定のケーブル(UL/CSEマークがコードに表記)を Supermicroが指定する製品以外に使用することを禁止しています。

警告

安裝此產品時，請使用本身提供的或指定的連接線，電源線和電源適配器。使用其它線材或適配器可能會引起故障或火災。除了 Supermicro 所指定的產品，電氣用品和材料安全法律規定禁止使用未經 UL 或 CSA 認證的線材。(線材上會顯示 UL/CSA 符號)。

警告

安裝此產品時，請使用本身提供的或指定的連接線，電源線和電源適配器。使用其它線材或適配器可能會引起故障或火災。除了 Supermicro 所指定的產品，電氣用品和材料安全法律規定禁止使用未經 UL 或 CSA 認證的線材。(線材上會顯示 UL/CSA 符號)。

Warnung

Bei der Installation des Produkts, die zur Verfügung gestellten oder benannt Anschlusskabel, Stromkabel und Netzteile. Verwendung anderer Kabel und Adapter kann zu einer Fehlfunktion oder ein Brand entstehen. Elektrische Geräte und Material Safety Law verbietet die Verwendung von UL-oder CSA-zertifizierte Kabel, UL oder CSA auf der Code für alle anderen elektrischen Geräte als Produkte von Supermicro nur bezeichnet gezeigt haben.

¡Advertencia!

Al instalar el producto, utilice los cables de conexión previstos o designados, los cables y adaptadores de CA. La utilización de otros cables y adaptadores podría ocasionar un mal funcionamiento o un incendio. Aparatos Eléctricos y la Ley de Seguridad del Material prohíbe el uso de UL o CSA cables certificados que tienen UL o CSA se muestra en el código de otros dispositivos eléctricos que los productos designados por Supermicro solamente.

Attention

Lors de l'installation du produit, utilisez les bables de connection fournis ou désigné. L'utilisation d'autres cables et adaptateurs peut provoquer un dysfonctionnement ou un incendie. Appareils électroménagers et de loi sur la sécurité Matériel interdit l'utilisation de UL ou CSA câbles certifiés qui ont UL ou CSA indiqué sur le code pour tous les autres appareils électriques que les produits désignés par Supermicro seulement.

חשמליים ומתאמי AC**אזהרה !**

כאשר מתקינים את המוצר, יש להשתמש בכבלים, ספקים ומתאמים AC אשר נועדו וסופקו לשם כך. שימוש בכל כבל או מתאם אחר יכול לגרום לתקלה או קצר חשמלי. על פי חוקי שימוש במכשירי חשמל וחוקי בטיחות, קיים איסור להשתמש בכבלים המוסמכים ב- UL או ב- CSA (כשאר מופיע עליהם קוד של UL/CSA) עבור כל מוצר חשמלי אחר שלא צויין על ידי סופרמיקרו בלבד.

عند تركيب الجهاز يجب استخدام كابلات التوصيل، والكابلات الكهربائية ومحولات التيار المتردد

التي . أن استخدام أي كابلات ومحولات أخرى يتسبب في حدوث عطل أو حريق. تم توفيرها لك مع المنتج

الأجهزة الكهربائية ومواد قانون السلامة يحظر استخدام الكابلات CSA أو UL معتمدة من قبل

لأي أجهزة كهربائية أخرى غير المنتجات المعينة من قبل Supermicro (التي تحمل علامة UL/CSA)

경고!

제품을 설치할 때에는 제공되거나 지정된 연결케이블과 전원케이블, AC어댑터를 사용해야 합니다. 그 밖의 다른 케이블들이나 어댑터들은 고장 또는 화재의 원인이 될 수 있습니다. 전기용품안전법 (Electrical Appliance and Material Safety Law)은 슈퍼마이크로에서 지정된 제품들 외에는 그 밖의 다른 전기 장치들을 위한 UL 또는 CSA에서 인증한 케이블(전선 위에 UL/CSA가 표시)들의 사용을 금지합니다.

Waarschuwing

Bij het installeren van het product, gebruik de meegeleverde of aangewezen kabels, stroomkabels en adapters. Het gebruik van andere kabels en adapters kan leiden tot een storing of een brand. Elektrisch apparaat en veiligheidsinformatiebladen wet verbiedt het gebruik van UL of CSA gecertificeerde kabels die UL of CSA die op de code voor andere elektrische apparaten dan de producten die door Supermicro alleen.

Chapter 5

Advanced Motherboard Setup

This chapter covers the steps required to connect the A1SRi-2358F data and power cables. Motherboard jumpers and connections are also described. A layout and quick reference chart are included in this chapter for your reference.

Note: For this server, the CPU heatsink are pre-installed on the motherboard, and not replicable by the user.

5-1 Handling the Motherboard

Electrostatic Discharge (ESD) can damage electronic components. To prevent damage to any printed circuit boards (PCBs), it is important to handle them very carefully (see previous chapter). To prevent the motherboard from bending, keep one hand under the center of the board to support it when handling. The following measures are generally sufficient to protect your equipment from electric static discharge.

Precautions

- Use a grounded wrist strap designed to prevent ESD.
- Touch a grounded metal object before removing boards from antistatic bags.
- Handle a board by its edges only; do not touch its components, peripheral chips, memory modules or gold contacts.
- When handling chips or modules, avoid touching their pins.
- Put the motherboard, add-on cards and peripherals back into their antistatic bags when not in use.
- For grounding purposes, make sure your computer chassis provides excellent conductivity between the power supply, the case, the mounting fasteners and the motherboard.

Unpacking

The motherboard is shipped in antistatic packaging to avoid electrical static discharge. When unpacking the board, make sure the person handling it is static protected.

5-2 Connecting Cables

Once the motherboard is installed, the cables must be connected. These include the data (ribbon) cables for the peripherals and control panel and the power cables. See section 4-5 for connectors.

Connecting Data Cables

The ribbon cables used to transfer data from the peripheral devices have been carefully routed to prevent them from blocking the flow of cooling air that moves through the system from front to back. If you need to disconnect any of these cables, you should take care to keep them routed as they were originally after reconnecting them (make sure the red wires connect to the pin 1 locations). The following data cables (with their locations noted) should be connected.

- SATA drive data cables (I-SATA0 ~ 5)
- Control Panel cable (JF1)

Important! Make sure the the cables do not come into contact with the fans.

Connecting Power Cables

The motherboard has two power supply connectors, JPW1 and JPW2.

Connecting the Control Panel

The JF1 connector contains header pins for the front control panel.

All JF1 wires have been bundled into a single ribbon cable to simplify this connection. Make sure the red wire plugs into pin 1 as marked on the board. The other end connects to the Control Panel PCB board, located just behind the system status LEDs on the chassis.

5-3 I/O Ports

Figure 5-1. Rear I/O Ports

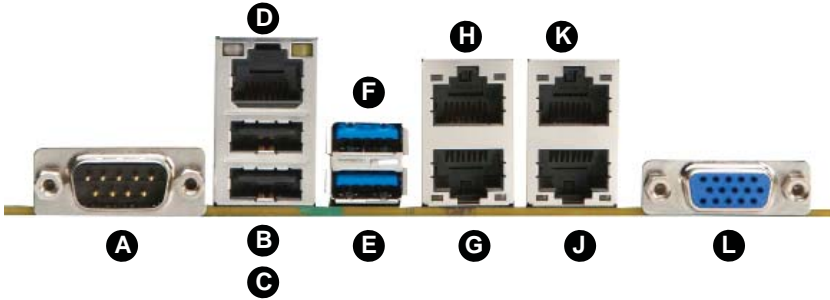

Back Panel I/O		
A. COM Port	E. USB 3.0	J. LAN
B. USB 2.0	F. USB 3.0	K. LAN
C. USB 2.0	G. LAN	L. VGA
D. IPMI LAN	H. LAN	

5-4 Memory Support

The A1SRi-2358F motherboard supports up to 64 GB of DDR3 ECC Unbuffered SODIMM 1600/1333 MHz in four memory slots. SODIMM sizes 2, 4, 8, or 16 GB are acceptable. Populating these with a pair of memory modules of the same type and same size results in interleaved memory, and provides superior memory performance.

Note: Check the Supermicro website for recommended memory modules.

Memory Population Guidelines

Please follow the table below when populating the motherboard.

Unbuffered DDR3 ECC SODIMM Memory				
DIMM Slots per Channel	DIMMs Populated per Channel	DIMM Type	POR Speeds	Memory Population Sequence
2	1	Unbuffered DDR3 SODIMM	1600,1333	A1, B1 (2 DIMMs)
2	2	Unbuffered DDR3 SODIMM	1600,1333	A1, B1, A2, B2 (4 DIMMs)

Figure 5-3. Memory Slot Labels

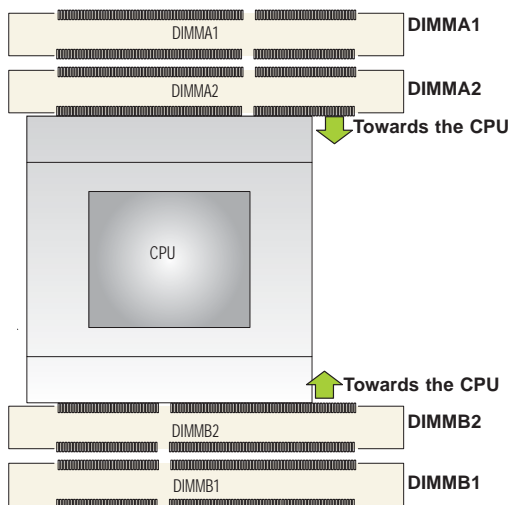

When installing memory modules, the DIMM slots should be populated in the following order: DIMMA1, DIMMB1, then DIMMA2, DIMMB2.

Notes:

- Use SODIMM modules of the same size, type and speed. Do not mix.
- For best memory performance, install SODIMM modules in pairs. The motherboard will support installing one module, but it is not optimal.
- Due to memory allocation to system devices, the amount of memory that remains available for operational use will be reduced when 4 GB of RAM is used. The reduction in memory availability is disproportional. See the following table for details.

Installing SODIMM Memory Modules

Caution: Exercise extreme care when installing or removing DIMM modules to prevent damage.

1. Align the key on the bottom of the DIMM module against the key on the memory slot. Take note of the notches on the side of the DIMM module and of the locking clips on the socket to avoid causing damage.

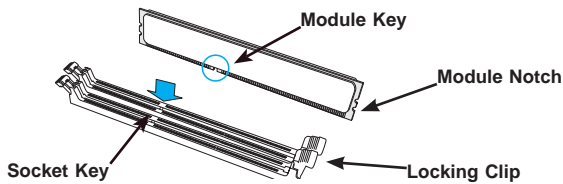

2. Install the SODIMM module straight down into the socket until it is securely seated in the socket. The side clips will automatically lock the module into place.

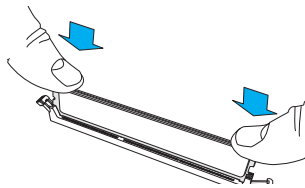

5-5 Expansion Cards

The motherboard supports one low profile PCI Express 2.0 x8 card. Refer to Chapter 5 for instructions on installing an expansion card in the system.

5-6 Motherboard Details

Figure 4-4. A1SRi-2358F Motherboard Layout

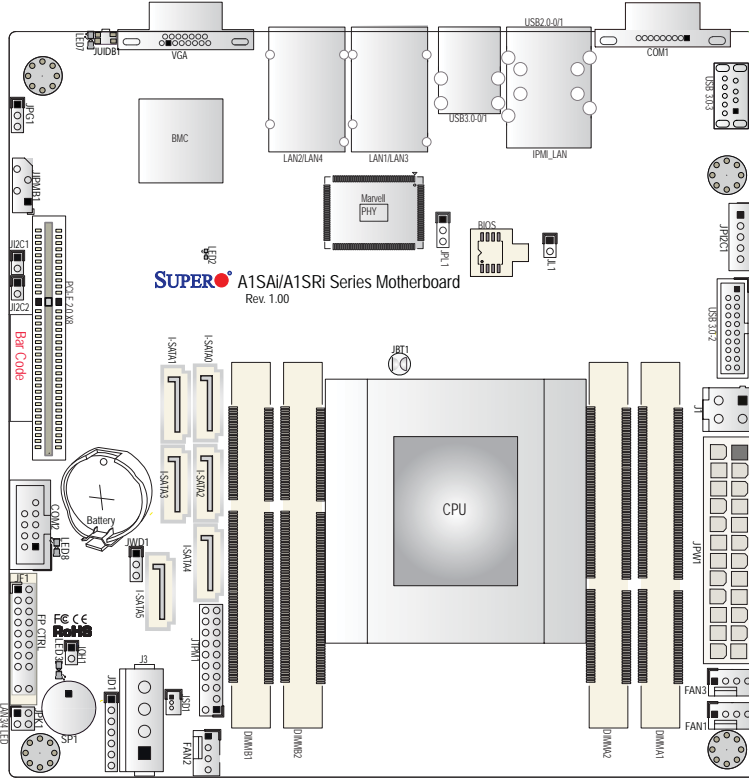

Notes:

1. " " indicates the location of "Pin 1". Jumpers not indicated are for testing only.
2. When LED3 (Onboard Power LED Indicator) is on, system power is on. Unplug the power cable before installing or removing any components.
3. The motherboard supports Intel QuickAssist Technology to enhance network routing and internet security for communications systems.
4. The motherboard supports Turbo Boost Technology, offering turbo-boost capabilities to maximize system performance for server platforms.

A1SRi-2358F Motherboard Quick Reference

Headers/Connectors	
Connector	Description
Battery (JBAT1)	Onboard Battery
COM1/COM2	COM1 Port/COM 2 Header
FAN1-FAN3	CPU/System Cooling Fans
J1*	4-pin 12V DC Power Connector (alternate power to 24-pin ATX)
J3	mSATA Slot (MUX with I-SATA0)
JD1	Speaker/Buzzer (Pins 1-3: Power LED, Pins 4-7: Speaker)
JF1	Front Panel Control Header
JIPMB1	4-pin External SMBus I2C Header (for an IPMI Card)
JL1	Chassis Intrusion Header
JOH1	Overheat LED Header
JPIC1	Power Supply System Management Bus (SMBus) I2C Header
JPK1	LAN3/LAN4 LED Indication Header
JPW1	24-pin ATX Main Power connector
JSD1	SATA DOM (Device_On_Module) Power Connector
JTPM1	Trusted Platform Module (TPM)/Port 80 Connector
JUID1	Unit Identifier (UID) Button
LAN1-4	Gigabit Ethernet (RJ45) Ports
I-SATA 0-5	Intel Serial ATA Ports (I-SATA4 supports SuperDOM)
PCI-E Slot	PCI-E slot 2.0 x4 (in x8)
SP1	Internal Speaker/Buzzer
USB2.0-0/1	Rear panel USB 2.0 Ports
USB3.0-0/1	Rear panel USB 3.0 Ports
USB 2/3	Front Access (USB 3.0 port 2) & Type A Connector (USB 3.0 port 3)
VGA	Backpanel VGA Port

Note: *Do not use the 4-pin DC power at J1 when the 24-pin ATX Power at JPW1 is connected to the power supply. Do not plug in both J1 and JPW1 at the same time.

Jumpers		
Jumper	Description	Default
JBT1	CMOS Clear	Open: Normal, Short: Clear CMOS
J1 ² C1/J1 ² C2	SMB to PCI-Exp. Slots	Pins 2-3 (Disabled)
JPG1	VGA Enable	Pins 1-2 (Enabled)
JPL1	Ethernet LAN Ports Enable	Pins 1-2 (Enabled)
JWD1	Watch Dog Enable	Pins 1-2 (Reset)

LED Indicators			
LED	Description	Color/State	Status
LED2	BMC Heartbeat LED	Green: Blinking	BMC: Normal
LED3	Power LED	Green: On	System Power On
LED7	UID Switch LED	Blue: On	Unit Identified
LED8	Overheat/PWR Fail/Fan Fail LED	Red: Solid on/Blinking	Solid On: Overheat, Blinking: PWR Fail or Fan Fail

5-7 Connector Definitions

Power Connectors

The 24-pin ATX power connector header (JPW1) is used to provide power to the motherboard. The 4-pin connector, J1, is the 12V DC power connector that provides alternative power for special enclosures when the 24-pin ATX power is not used. The 4-pin HDD power connector J3 provides power to onboard HDD devices.

Note: Do not use the 4-pin DC power at J1 when the 24-pin ATX Power at JPW1 is connected to the power supply.

ATX Power 24-pin Connector Pin Definitions (JPW1)			
Pin#	Definition	Pin#	Definition
13	+3.3V	1	+3.3V
14	NC	2	+3.3V
15	COM	3	COM
16	PS_ON	4	+5V
17	COM	5	COM
18	COM	6	+5V
19	COM	7	COM
20	NC	8	PWR_OK
21	+5V	9	5VSB
22	+5V	10	+12V
23	+5V	11	+12V
24	COM	12	+3.3V

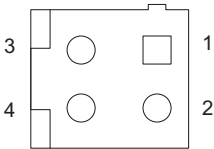

4-Pin HDD Power Pin Definitions (J1)	
Pin#	Definition
1,2	GND
3,4	12V

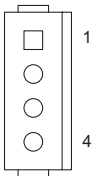

4-Pin HDD Power Pin Definitions (J3)	
Pin#	Definition
1	12V
2-3	GND
4	5V

Control Panel Connectors

Figure 5-5. Control Panel Header Pins

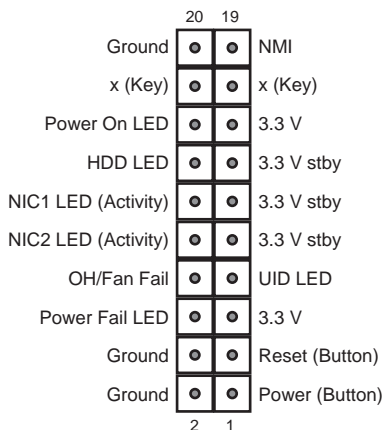

Power Button

The Power Button connection is located on pins 1 and 2 of JF1. Momentarily contacting both pins will power on/off the system. This button can also be configured to function as a suspend button (with a setting in the BIOS - see Chapter 7). To turn off the power in the suspend mode, press the button for at least 4 seconds. Refer to the table on the right for pin definitions.

Power Button Pin Definitions (JF1)	
Pin#	Definition
1	Signal
2	Ground

Reset Button

The reset button is located on pins 3 and 4 of JF1 and attaches to the reset switch on the computer chassis. See the table on the right for pin definitions.

Reset Button Pin Definitions (JF1)	
Pin#	Definition
3	Reset
4	Ground

Power Fail LED

The Power Fail LED connection is located on pins 5 and 6 of JF1. Refer to the table on the right for pin definitions.

PWR Fail LED Pin Definitions (JF1)	
Pin#	Definition
5	3.3V
6	PWR Supply Fail

Unit ID LED (Front Panel)

Connect an LED cable to pins 7 and 8 of Front Control Panel to use the Overheat/Fan Fail/Power Fail and UID LED connections. These functions are described in Chapter 3; more UID description in Section 4-10.

OH/Fan Fail/ PWR Fail/Blue_ UID LED Pin Definitions (JF1)	
Pin#	Definition
7	Blue_UID LED
8	OH/Fan Fail/Power Fail Cathode

NIC1/NIC2 (LAN1/LAN2)

The NIC (Network Interface Controller) LED connection for LAN ports 6 and 7 are located on pins 11 and 12 and pins 9 and 10 of JF1, respectively. Attach NIC LED cables to the NIC6 and NIC7 LED indicators to display network activity. Refer to the table on the right for pin definitions.

LAN1/LAN2 LED Pin Definitions (JF1)	
Pin#	Definition
9/11	3.3V Standby
10/12	NIC Activity LED

HDD LED

The HDD LED connection is located on pins 13 and 14 of JF1. Attach a cable here to indicate the status of HDD-related activities. See the table on the right for pin definitions.

HDD LED Pin Definitions (JF1)	
Pin#	Definition
13	3.3 V Stby
14	HDD LED

HDD LED Status	
State	Definition
Off	No Activity
Blinking	HDD Busy

Power LED

The Power LED connection is located on pins 15 and 16 of JF1. Refer to the table on the right for pin definitions.

Power LED Pin Definitions (JF1)	
Pin#	Definition
15	+5V
16	Ground

NMI Button

The non-maskable interrupt button header is located on pins 19 and 20 of JF1. Refer to the table on the right for pin definitions.

NMI Button Pin Definitions (JF1)	
Pin#	Definition
19	Control
20	Ground

Input/Output Connectors**Universal Serial Bus (USB)**

Two Universal Serial Bus 2.0 ports (0/1) and two USB 3.0 ports (0/1) are located on the I/O rear panel. One USB 3.0 header (USB2/3) can provide front panel access; USB 3.0 port 3 is Type A connector. Cables are not included. See the tables at the right for pin definitions.

USB2/3 Header Pin Definitions			
Pin #	Definition	Pin #	Definition
1	+5V	2	+5V
3	USB_PN2	4	USB_PN3
5	USB_PP2	6	USB_PP3
7	Ground	8	Ground
9	Key	10	Ground

Ethernet Ports (LAN1/LAN2)

Four Gigabit Ethernet ports (LAN1/3, 2/4) are located on the I/O rear panel ports accepting RJ45 type plugs. In addition, a LAN port is dedicated to IPMI, supported by the BMC controller.

Unit Identifier Switch (UID)

The Unit ID switch is located on the I/O rear panel.

Serial Ports

COM1 port is located on I/O rear panel to provide a serial port connection. The COM2 header is located next to the PCI-E slot to provide a front accessible serial connection.

VGA

A VGA port is located next to the LAN6/LAN7 ports on the I/O rear panel.

Other Connectors

Fan Headers

There are three fan 4-pin headers. Pins 1-3 are backward compatible with the traditional 3-pin fans, but you can use 4-pin fans to take advantage of the fan speed control using Pulse Width Modulation through the BMC. This allows the fan speeds to be automatically adjusted based on the motherboard temperature. Refer to the table on the right for pin definitions.

Fan Header Pin Definitions	
Pin#	Definition
1	Ground (Black)
2	+12V (Red)
3	Tachometer
4	PWM_Control

Chassis Intrusion

A Chassis Intrusion header is located at JL1 on the motherboard. Attach the appropriate cable from the chassis to inform you of a chassis intrusion when the chassis is opened.

Chassis Intrusion Pin Definitions (JL1)	
Pin#	Definition
1	Intrusion Input
2	Ground

Internal Buzzer (SP1)

The Internal Buzzer (SP1) can be used to provide audible indications for various beep codes. See the table on the right for pin definitions.

Internal Buzzer Pin Definition		
Pin#	Definitions	
Pin 1	Pos. (+)	5V
Pin 2	Neg. (-)	Beep In

DOM PWR Connector (JSD1)

The Disk-On-Module (DOM) power connector, located at JSD1, provides 5V (Gen1/Gen) power to a solid-state DOM storage device connected to one of the SATA ports. See the table on the right for pin definitions.

DOM PWR Pin Definitions	
Pin#	Definition
1	5V
2	Ground
3	Ground

TPM Header

The JTPM1 header is used to connect a Trusted Platform Module (TPM), which is available from a third-party vendor. A TPM is a security device that supports encryption and authentication in hard drives. It enables the motherboard to deny access if the TPM associated with the hard drive is not installed in the system. See the table on the right for pin definitions.

Trusted Platform Module Header (JTPM1) Pin Definitions			
Pin #	Definition	Pin #	Definition
1	LCLK	2	GND
3	LFRAME#	4	No Pin
5	LRESET#	6	+5V (X)
7	LAD3	8	LAD2
9	+3.3V	10	LAD1
11	LAD0	12	GND
13	NC	14	NC
15	+3V_DUAL	16	SERIRQ
17	GND	18	GND
19	3.3V	20	NC)

Overheat/Fan Fail LED

The JOH1 header is used to connect an LED indicator to provide warnings of chassis overheat. Refer to the table on right for pin definitions.

OH/Fan Fail LED (JOH1) Pin Definitions	
Pin#	Definition
1	3.3V
2	OH Active

OH/Fan Fail LED	
State	Message
Off	Normal
Flashing	Fan fail
Solid	Overheat

LAN3/LAN4 Activity LED Header

The JPK1 header provides LAN3/4 LED activity. LAN1/LAN2 LED indicator connections are located on pins 9/10 and 11/12 of the front control panel (JF1).

JPK1 LAN Activity LED Pin Definitions	
Pin#	Definition
1	3.3V Stby
2	LAN4 Activity LED
3	3.3V Stby
4	LAN3 Activity LED

PSU SMB (I²C) Connector

Power System Management Bus (I²C) Connector (JPI²C1) monitors power supply, fan and system temperatures. See the table on the right for pin definitions.

PSU SMB Pin Definitions	
Pin#	Definition
1	Clock
2	Data
3	PWR Fail
4	Ground
5	NC

System Management Bus Header

A System Management Bus header for IPMI 2.0 is located at JIPMIB1. Connect the appropriate cable here to use the IPMI I²C connection on your system.

SMBus Header Pin Definitions	
Pin#	Definition
1	Data
2	Ground
3	Clock
4	No Connection

Power LED/Speaker

On JD1 header, pins 1-3 are used for power LED indication, and pins 4-7 are for the speaker. See the tables on the right for pin definitions. The speaker connector pins (4-7) are used with an external speaker. If you wish to use the onboard speaker, close pins 6-7 with a jumper (default).

PWR LED Connector Pin Definitions	
Pin#	Definition
1	Anode (+)
2	Cathode (-)
3	NA

Speaker Connector Pin Definitions	
Pin	Definition
4-7	External Speaker
6-7	Internal Speaker (Default)

5-8 Jumper Settings

Explanation of Jumpers

To modify the operation of the motherboard, jumpers can be used to choose between optional settings. Jumpers create shorts between two pins to change the function of the connector. Pin 1 is identified with a square solder pad on the printed circuit board. See the motherboard layout pages for jumper locations.

Note: On a two-pin jumper, "Closed" means the jumper is on both pins and "Open" means the jumper is either on only one pin or completely removed.

CMOS Clear

JBT1 is used to clear CMOS (which will also clear any passwords). Instead of pins, this jumper consists of contact pads to prevent accidentally clearing the contents of CMOS.

To clear CMOS,

1. First power down the system and unplug the power cord(s).
2. With the power disconnected, short the CMOS pads with a metal object such as a small screwdriver.
3. Remove the screwdriver (or shorting device).
4. Reconnect the power cord(s) and power on the system.

Note: Do not use the PW ON connector to clear CMOS.

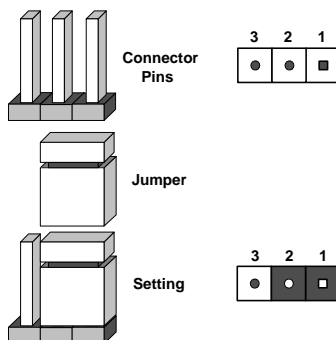

LAN Ports Enable/Disable

Jumper JPL1 enables or disables Ethernet LAN ports on the motherboard. See the table on the right for jumper settings. The default setting is enabled.

GbE LAN Enable Jumper Settings	
Setting	Definition
Pins 1-2	Enabled (default)
Pins 2-3	Disabled

VGA Enable/Disable

JPG1 allows you to enable or disable the VGA port. The default position is on pins 1 and 2 to enable VGA. See the table on the right for jumper settings.

VGA Enable/Disable Jumper Settings	
Setting	Definition
Pins 1-2	Enabled
Pins 2-3	Disabled

PCI Slot SMB Enable (J12C1/J12C2)

Use Jumpers I²C1/I²C2 to enable PCI SMB (System Management Bus) support to improve system management for the onboard PCI-E slot. See the table on the right for jumper settings.

PCI Slot SMB Enable (J12C) Jumper Settings	
Setting	Definition
Short	Enabled
Open	Disabled (Default)

Watch Dog Timer Enable

Watch Dog (JWD1) is a system monitor that can be used to reset the system or enter NMI when the Timer expires. Close pins 1-2 to reset the system if an application hangs. Close pins 2-3 to generate a non-maskable interrupt signal for the application that hangs. See the table on the right for jumper settings. Watch Dog may be enabled in the BIOS Setup. The default timer is around 5 minutes.

Watch Dog Jumper Settings	
Setting	Definition
Pins 1-2	Reset (default)
Pins 2-3	NMI
Open	Disable

5-9 Onboard Indicators

GbE LAN LEDs

There are four GbE LAN ports on the motherboard. Each Gigabit Ethernet LAN port has two LEDs. The Yellow LED on the right indicates connection and activity. The Link LED on the left side may be green, amber or off to indicate the speed of the connection. See the tables at right for more information.

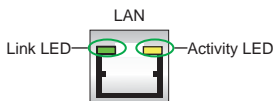

LAN Port Activity LED (Left) LED State		
Color	Status	Definition
Orange	Flashing	Active

1Gbps LAN Link LED Settings	
Color	Definition
Off	No Connection, 10 Mbps
Green	100 Mbps
Amber	1 Gbps

IPMI Dedicated LAN LEDs

In addition to LAN ports, an IPMI Dedicated LAN is also located on the I/O Backplane of the motherboard. The amber LED on the right indicates connection and activity, while the green LED on the left indicates the speed of the connection. See the tables at right for more information.

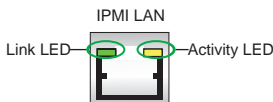

IPMI LAN Link/Speed LED (Left) & Activity LED (Right)		
LED	Color/Status	Definition
Link (Left)	Green: Solid	100 Mbps
	Amber: Solid	1 Gbps
Activity (Right)	Orange: Blinking	Active

Onboard Power LED

An Onboard Power LED is located at LED3 on the motherboard. When this LED is on, the system is on. See the table on the right for more information.

Onboard PWR LED Indicator LED Settings	
LED Color	Definition
Off	System Off (PWR cable not connected)
Green	System On

Overheat/PWR Fail/Fan Fail LED

An onboard Overheat/PWR Fail/Fan Fail LED is located at LED8. See the tables on the right for more information.

Overheat/PWR Fail/Fan Fail LED Settings	
Color/State	Definition
Solid	Overheat
Blinking	PWR Fail or Fan Fail

Unit Identification LED

Unit identifier (UID) LEDs help identify the server in a rack. A rear UID LED indicator (LED7) is located next to the UID switch on the I/O rear panel. The front control panel UID LED is connected to pin 7 of JF1. It is combined with the Overheat/PWR Fail/Fan Fail LED.

The UID function can be activated by the UID switch on the I/O rear panel or through IPMI. When activated, both front and rear LEDs are lighted blue. For the front LED, the red Overheat/PWR Fail/Fan Fail warnings take precedence over the blue UID by default.

Press the UID switch again to turn off both.

5-10 SATA Ports**SATA Ports (I-SATA0 - I-SATA5)**

There are six SATA ports on the motherboard. I-SATA0/1 support SATA 3.0 connections. I-SATA2~5 are SATA 2.0 ports. They provide serial-link signal connections for hard disk drives.

5-11 Installing Software

The Supermicro ftp site contains drivers and utilities for your system at <ftp://ftp.supermicro.com>. Some of these must be installed, such as the chipset driver.

After accessing the ftp site, go into the CDR_Images directory and locate the ISO file for your motherboard. Download this file to create a CD/DVD of the drivers and utilities it contains. (You may also use a utility to extract the ISO file if preferred.)

Another option is to go to the Supermicro Website at <http://www.supermicro.com/products/>. Find the product page for your motherboard here, where you may download individual drivers and utilities.

After creating a CD/DVD with the ISO files, insert the disk into the CD/DVD drive on your system and the display shown in Figure 5-6 should appear.

Figure 5-6. Driver/Tool Installation Display Screen

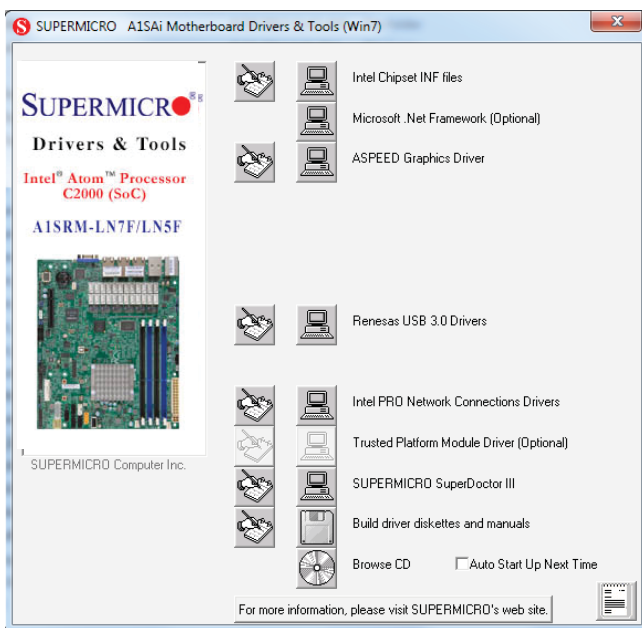

Note: Click the icons showing a hand writing on paper to view the readme files for each item. Click the computer icons to the right of these items to install each item (from top to the bottom) one at a time. After installing each item, you must reboot the system before moving on to the next item on the list. The bottom icon with a CD on it allows you to view the entire contents.

SuperDoctor® 5

The Supermicro SuperDoctor® 5 is a hardware and operating system services monitoring program that functions in a command-line or web-based interface in Windows and Linux operating systems. The program monitors system health information such as CPU temperature, system voltages, system power consumption, fan speed, and provides alerts via email or Simple Network Management Protocol (SNMP).

SuperDoctor 5 comes in local and remote management versions and can be used with Nagios to maximize your system monitoring needs. With SuperDoctor 5 Management Server (SSM Server), you can remotely control power on/off and reset chassis intrusion for multiple systems with SuperDoctor 5 or IPMI. SD5 Management Server monitors HTTP, FTP, and SMTP services to optimize the efficiency of your operation.

Note: The default User Name and Password for SuperDoctor 5 is ADMIN/ADMIN.

Figure 5-7. SuperDoctor 5 Interface Display Screen (Health Information)



Figure 5-8. SuperDoctor 5 Interface Display Screen (Remote Control)

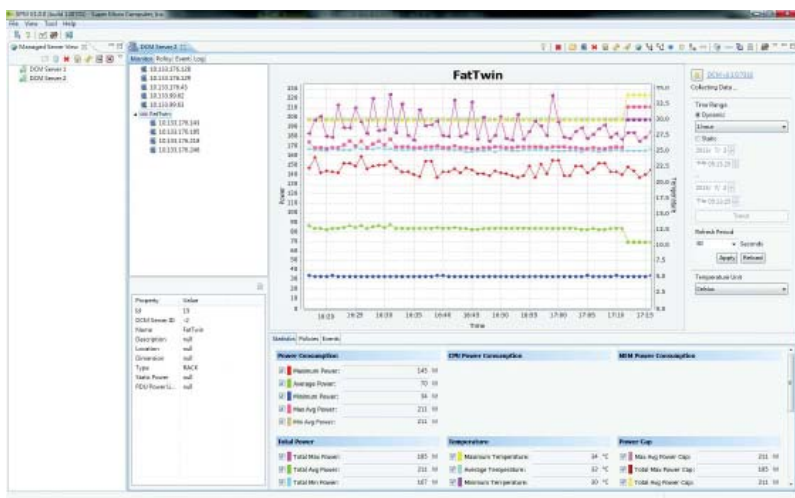

Note: The SuperDoctor 5 program and User's Manual can be downloaded from the Supermicro web site at http://www.supermicro.com/products/info/sms_sd5.cfm. For Linux, we recommend that you use the SuperDoctor II application instead.

5-12 Serverboard Battery

Caution: There is a danger of explosion if the onboard battery is installed upside down, which will reverse its polarities. This battery must be replaced only with the same or an equivalent type recommended by the manufacturer (CR2032). Dispose of used batteries according to the manufacturer's instructions.

Figure 5-9. Installing the Onboard Battery

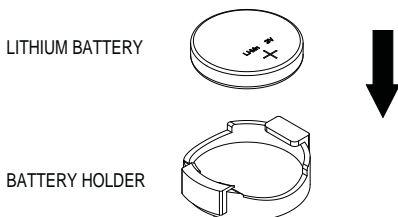

Please handle used batteries carefully. Do not damage the battery in any way; a damaged battery may release hazardous materials into the environment. Do not discard a used battery in the garbage or a public landfill. Please comply with the regulations set up by your local hazardous waste management agency to dispose of your used battery properly.

Chapter 6

Advanced Chassis Setup

This chapter covers the steps required to install components and perform maintenance on the SC504-203B chassis. For component installation, follow the steps in the order given to eliminate the most common problems encountered. If some steps are unnecessary, skip ahead to the step that follows.

Tools Required: The only tool you will need to install components and perform maintenance is a Philips screwdriver.

6-1 Static-Sensitive Devices

Electrostatic discharge (ESD) can damage electronic components. To prevent damage to any printed circuit boards (PCBs), it is important to handle them very carefully. The following measures are generally sufficient to protect your equipment from ESD damage.

Precautions

- Use a grounded wrist strap designed to prevent static discharge.
- Touch a grounded metal object before removing any board from its antistatic bag.
- Handle a board by its edges only; do not touch its components, peripheral chips, memory modules or gold contacts.
- When handling chips or modules, avoid touching their pins.
- Put the motherboard, add-on cards and peripherals back into their antistatic bags when not in use.
- For grounding purposes, make sure your computer chassis provides excellent conductivity between the power supply, the case, the mounting fasteners and the motherboard.

Unpacking

The motherboard is shipped in antistatic packaging to avoid static damage. When unpacking the board, make sure the person handling it is static protected.

Figure 6-1. Front and Rear Chassis Views

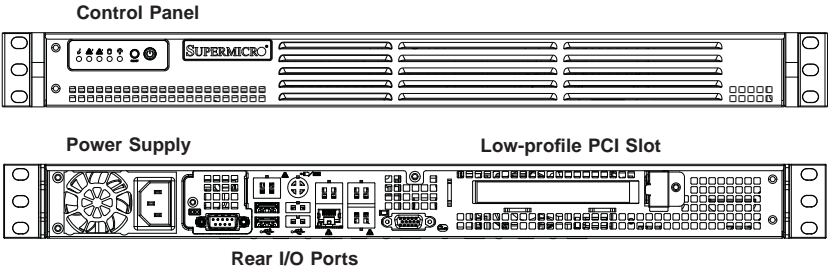

6-2 Control Panel

The control panel (located on the front of the chassis) must be connected to the JF1 connector on the motherboard to provide you with system status indications. A ribbon cable has bundled these wires together to simplify the connection. Connect the cable from JF1 on the motherboard to the Control Panel PCB (printed circuit board). Make sure the red wire plugs into pin 1 on both connectors. Pull all excess cabling out of the airflow path. The LEDs inform you of system status.

See Chapter 3 for details on the LEDs and the control panel buttons. Details on JF1 can be found in Chapter 5.

6-3 Removing the Chassis Cover

Figure 6-2. Removing the Chassis Cover

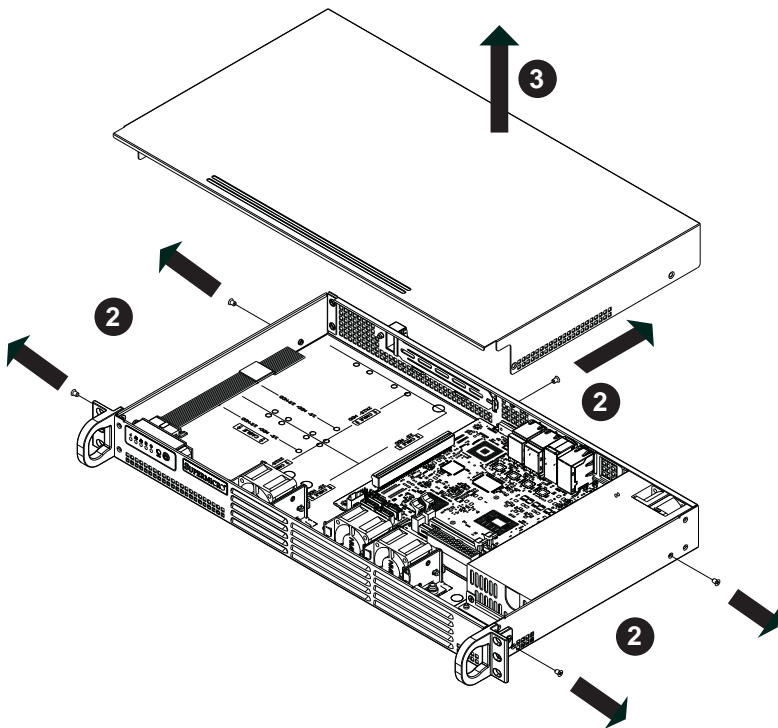

Removing the Chassis Cover

1. Power down the system and disconnect the power cord from the back of the power supply.
2. Remove the five screws that hold the chassis cover in place. There are two screws on each side of the chassis, and one screw on the back.
3. Once the screws have been removed, lift the cover upward to remove it from the chassis.

Caution: Except for short periods of time, do NOT operate the server without the cover in place. The chassis cover must be in place to allow proper airflow and prevent overheating.

6-4 System Fans

One system fan is included in the system. Up to two additional (optional) fans may be installed in the SC504 chassis.

Installing Optional System Fans

1. Position the dual system fan housing in the front of the chassis, facing forward as illustrated above, in front of the motherboard.
2. Align the mounting holes in the fan housing with the holes in the floor of the chassis.
3. Secure the dual fan housing to the chassis with the screws provided.
4. Position the single system fan to the left of the dual system fans.
5. Align the mounting holes in the single fan housing with the holes in the floor of the chassis.
6. Secure the single fan housing to the floor of the chassis.
7. Connect the fan cables to the motherboard and put the cover back on the chassis.

6-5 Installing Hard Drives

Follow the instructions that follow to install either four 2.5" or two 3.5" hard drives.

Installing 3.5" Hard Drives

1. Power down the server, disconnect the power cord from the power supply and remove the cover.
2. Place the 3.5" hard drive into the chassis as illustrated above.
3. Secure the hard drive to the chassis floor by inserting four screws up through the underside of the chassis.
4. Connect the hard drive wiring, reinstall the chassis cover and power cord, then power up the server.

Installing 2.5" Hard Drives

2.5" hard drives may be installed in several different configurations. Review the supported configuration options on page 6-6.

1. Power down the server, disconnect the power cord from the power supply and remove the cover.
2. Install up to four 2.5" hard drive(s) into the hard drive bracket(s) and secure them to the bracket with the screws provided. (See page 6-6 for supported configuration options.)

3. Place the hard drive and bracket into the chassis as illustrated in Figure 6-3. If up to four 2.5" hard drives are desired, rotate the hard drive brackets ninety degrees and place them side by side before attaching them to the chassis.
4. Secure the hard drive bracket(s) to the chassis floor by inserting the screws up through the underside of the chassis.
5. Expansion cards must be installed after installing the 2.5" hard drives.
6. Connect the hard drive wiring, reinstall the chassis cover and power cord, then power up the server

Note: bracket part number is MCP-220-00044-0N

Hard Drive Configuration Options

2.5" and 3.5" hard drives are supported in the following configurations:

Figure 6-3. Installing Hard Drives

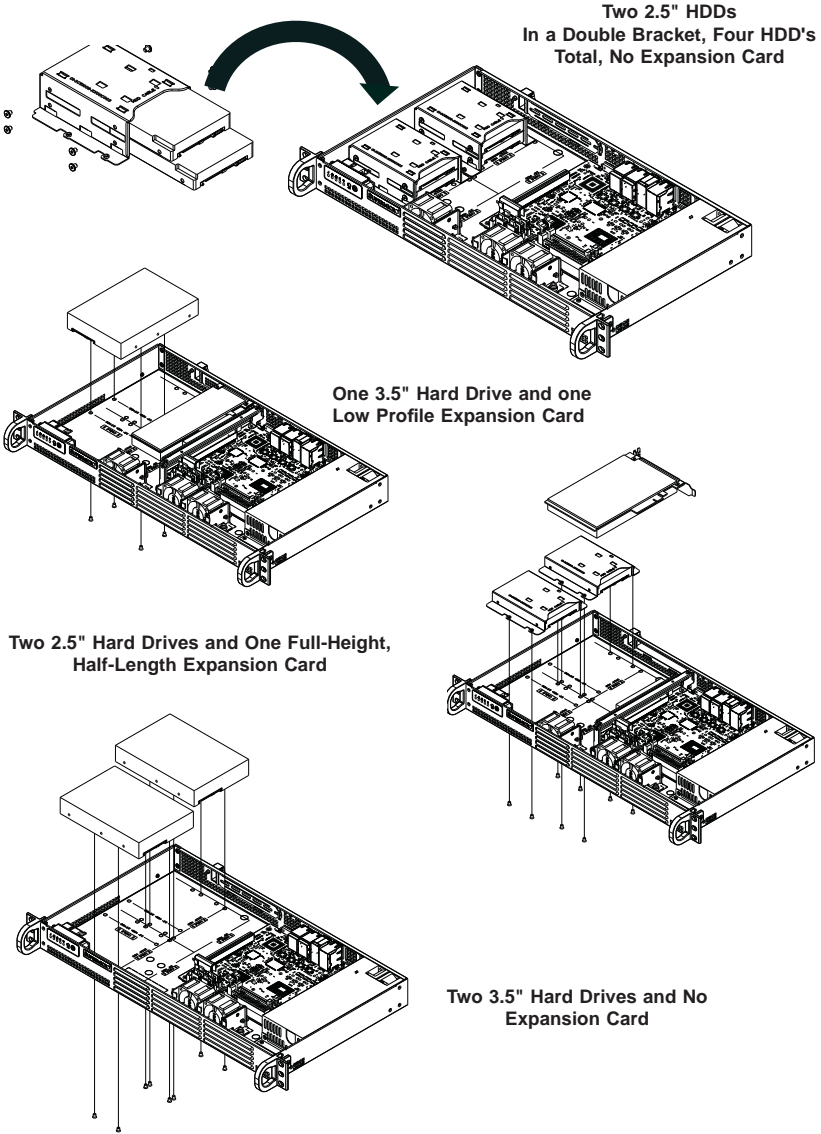

6-6 Installing an Expansion Card

The SC504 chassis includes a PCI slot for an optional full-height, half-length expansion card. A riser card is required in order to connect the expansion card to the motherboard. For further information on expansion on cards and risers cards, visit the Supermicro website at www.supermicro.com

Figure 6-4. Locating the Expansion Card Clip

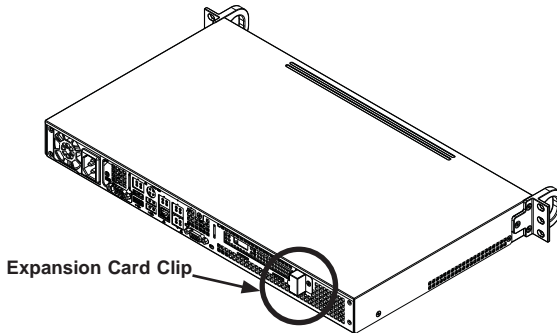

Installing the Expansion Card

1. Power down the server, disconnect the power cord from the power supply and remove the cover. Locate the expansion card clip on the back of the chassis
2. Remove the screws holding the expansion card clip and the PCI slot cover which covers the PCI slot opening in the back of the chassis.
3. Remove the expansion card clip and the PCI slot cover from the chassis.
4. Outside of the chassis, put the expansion card and the riser card together by inserting the expansion card into the riser card.

Figure 6-5. Installing the Expansion Card and Riser Card

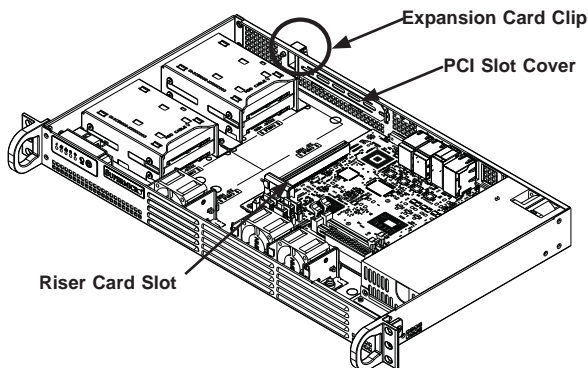

5. Simultaneously insert the PCI slot bracket of the expansion card into the open PCI slot and insert the riser card in to the riser card slot on the motherboard.

Figure 6-6. Installing the Expansion Card

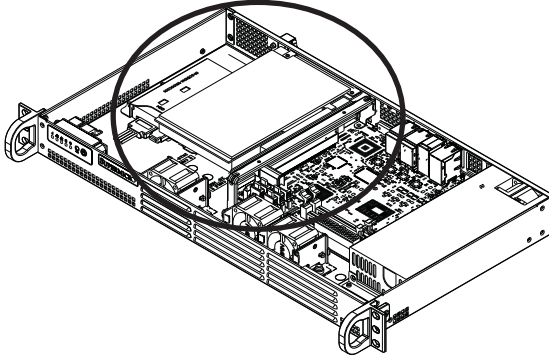

6. Replace the expansion card clip and screw it onto the chassis to hold the expansion card in place.

Figure 6-7. Replacing the Expansion Card Clip

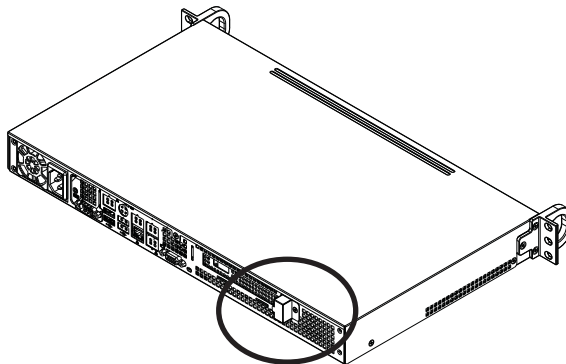

7. Replace the cover onto the chassis, reconnect the power cord and power up the server.

6-7 Power Supply

The SC504 chassis has a 200 Watt power supply. This power supply is auto-switching capable. This enables it to automatically sense and operate at a 100v to 240v input voltage. In the unlikely event that the power supply module fails, the system will shut down and you will need to replace the power supply module. New units can be ordered directly from Supermicro (see contact information in the Preface).

Replacing the Power Supply

Replacing the Power Supply

1. If the system is still operating, power it down then disconnect the power cord and remove the chassis cover.
2. Disconnect all wiring from the power supply.
3. Remove the four screws that hold the power supply in the chassis. Two rear mounting screws are located on the rear of the power supply. Two bottom mounting screws are accessed on the underside of the chassis and extend upwards through the mounting thru holes to hold the power supply in place. Set the screws aside for later use.

Figure 6-8. Installing the Power Supply

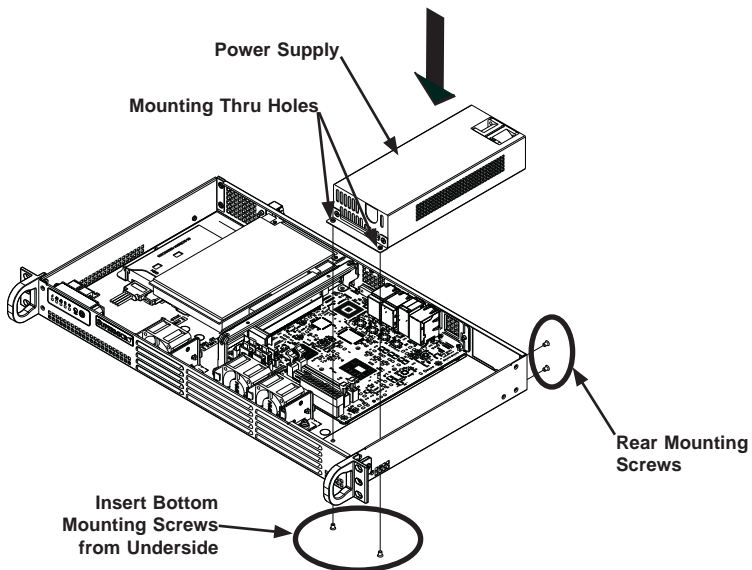

4. Remove the power supply from the chassis.
5. Align the mounting thru holes on the power supply with the mounting holes in the chassis and re-attach the power supply to the chassis using the four screws which were previously set aside
6. Reconnect the wiring and the power cord to the power supply, replace the cover and power up the server.

Chapter 7

BIOS

7-1 Introduction

This chapter describes the AMI BIOS Setup Utility for the A1SRi-2358F motherboard. The AMI ROM BIOS is stored in a Flash EEPROM and can be easily updated. This chapter describes the basic navigation of the AMI BIOS Setup Utility setup screens.

Note: For BIOS recovery, use the special recovery BIOS image AMI.ROM and special procedure based on FAQ 18625.

Starting BIOS Setup Utility

To enter the AMI BIOS Setup Utility screens, press the <Delete> key while the system is booting up.

Note: In most cases, the <Delete> key is used to invoke the AMI BIOS setup screen. There are a few cases when other keys are used, such as <F1>, <F2>, etc.

Each main BIOS menu option is described in this manual. The Main BIOS setup menu screen has two main frames. The left frame displays all the options that can be configured. Grayed-out options cannot be configured. Options in blue can be configured by the user. The right frame displays the key legend. Above the key legend is an area reserved for a text message. When an option is selected in the left frame, it is highlighted in white. Often informational text will accompany it. (**Note:** the AMI BIOS has default informational text built in. Supermicro retains the option to include, omit, or change any of these informational messages.)

The AMI BIOS Setup Utility uses a key-based navigation system called "hot keys". Most of the AMI BIOS setup utility "hot keys" can be used at any time during the setup navigation process. These keys include <F1>, <F10>, <Enter>, <ESC>, arrow keys, etc.

Note: Options printed in **Bold** are default settings.

How To Change the Configuration Data

The configuration data that determines the system parameters may be changed by entering the AMI BIOS Setup utility. This Setup utility can be accessed by pressing at the appropriate time during system boot.

How to Start the Setup Utility

Normally, the only visible Power-On Self-Test (POST) routine is the memory test. As the memory is being tested, press the <Delete> key to enter the main menu of the AMI BIOS setup utility. From the main menu, you can access the other setup screens. An AMI BIOS identification string is displayed at the left bottom corner of the screen, below the copyright message.

Warning: Do not update the BIOS unless your system has a BIOS-related issue. Flashing the wrong BIOS can cause irreparable damage to the system. In no event shall Supermicro be liable for direct, indirect, special, incidental, or consequential damages arising from a BIOS update. If you have to update the BIOS, do not shut down or reset the system while the BIOS is updating. This is to avoid possible boot failure.

7-2 Main Setup

When you first enter the AMI BIOS setup utility, you will enter the Main setup screen. You can always return to the Main setup screen by selecting the Main tab on the top of the screen. The Main BIOS Setup screen is shown below.

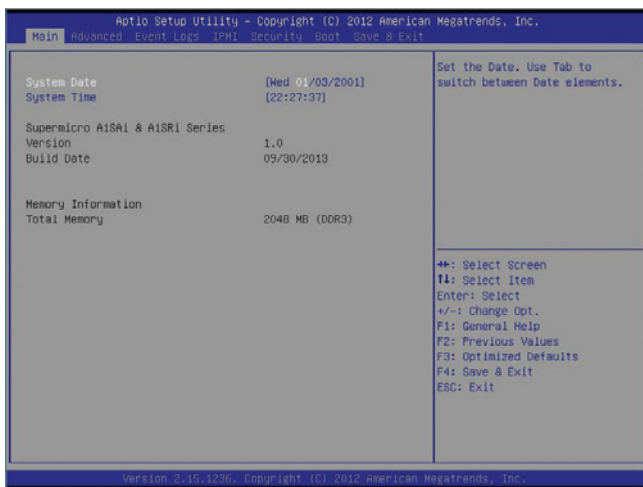

The following Main menu items will display:

System Date/System Time

Use this feature to change the system date and time. Highlight *System Date* or *System Time* using the arrow keys. Enter new values using the keyboard. Press the <Tab> key or the arrow keys to move between fields. The date must be entered in Day MM/DD/YY format. The time is entered in HH:MM:SS format.

Note: The time is in the 24-hour format. For example, 5:30 P.M. appears as 17:30:00.

The following BIOS items will also be displayed:

Supermicro A1SRi Series**Version****Build Date****Memory Information****Total Memory**

This displays the total size of memory available in the system.

7-3 Advanced Setup Configurations

Use the arrow keys to select Boot Setup and press <Enter> to access the submenu items.

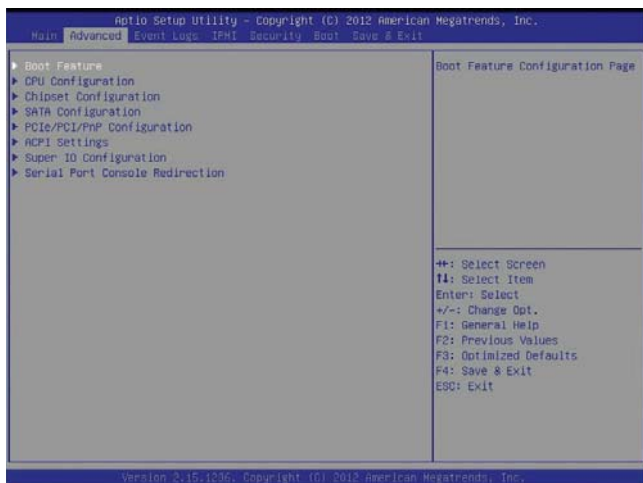

Warning: Take Caution when changing the Advanced settings. An incorrect value, a very high DRAM frequency, or an incorrect DRAM timing setting may make the system unstable. When this occurs, revert to the default to the manufacture default settings.

► Boot Feature

Quiet Boot

Use this feature to select the screen display between the POST messages and the OEM logo upon bootup. Select Disabled to display the POST messages. Select Enabled to display the OEM logo instead of the normal POST messages. The options are **Enabled** and Disabled.

AddOn ROM Display Mode

Use this feature to set the display mode for the Option ROM. Select Keep Current to display the current AddOn ROM setting. Select Force BIOS to use the Option ROM display set by the system BIOS. The options are **Force BIOS** and Keep Current.

Bootup Num-Lock

Use this feature to set the Power-on state for the <Numlock> key. The options are Off and **On**.

Wait For 'F1' If Error

Use this feature to force the system to wait until the 'F1' key is pressed if an error occurs. The options are Disabled and **Enabled**.

Interrupt 19 Capture

Interrupt 19 is the software interrupt that handles the boot disk function. When this item is set to Enabled, the ROM BIOS of the host adaptors will "capture" Interrupt 19 at bootup and allow the drives that are attached to these host adaptors to function as bootable disks. If this item is set to Disabled, the ROM BIOS of the host adaptors will not capture Interrupt 19, and the drives attached to these adaptors will not function as bootable devices. The options are **Immediately** and Postponed.

► Power Configuration**Watch Dog Function**

If enabled, the Watch Dog Timer will allow the system to reboot when it is inactive for more than 5 minutes. The options are Enabled and **Disabled**.

Power Button Function

This feature controls how the system shuts down when the power button is pressed. Select 4_Seconds_Override for the user to power off the system after pressing and holding the power button for 4 seconds or longer. Select Instant Off to instantly power off the system as soon as the user presses the power button. The options are 4 Seconds Override and **Instant Off**.

Restore on AC Power Loss

Use this feature to set the power state after a power outage. Select Stay-Off for the system power to remain off after a power loss. Select Power-On for the system power to be turned on after a power loss. Select Last State to allow the system to resume its last power state before a power loss. The options are Power-On, Stay-Off and **Last State**.

WOL (Wake-On_LAN) Support

Select Enabled to enable WOL support which will allow the system to "wake-up" when a device connected to a LAN port receives a signal. The options are Disabled and **Enabled**.

► CPU Configuration

The following CPU information will be displayed:

- Processor ID
- Processor Frequency
- Microcode Revision
- L1 Cache RAM
- L2 Cache RAM
- Processor Version

Clock Spread Spectrum

If this feature is set to Enabled, the BIOS utility will monitor the level of Electromagnetic Interference caused by the components and will attempt to reduce the interference whenever needed. The options are Enabled and **Disabled**.

EIST (GV3)

EIST (Enhanced Intel® SpeedStep Technology) GV3 allows the system to automatically adjust processor voltage and core frequency in an effort to reduce power consumption and heat dissipation. Select Auto to enable 80 CPU stepping support automatically and disabled other functions. The options are Disabled, Enabled, and **Auto**. **Please refer to the Intel® website for detailed information.**

P-STATE Coordination

This feature selects the type of coordination for the P-State of the processor. P-State is a processor operational state that reduces the processor's voltage and frequency to enhance CPU energy efficiency. The options are Hardware, **Package**, and Module.

TM1 (Available when supported by the CPU.)

Select Enable to activate TM1 support for system thermal monitoring. TM1 allows the CPU to regulate its power consumption based upon the modulation of the CPU Internal clock when the CPU temperature reaches a pre-defined overheating threshold. The options are Disabled and **Enabled**.

TM2 Mode (Available when supported by the CPU.)

Use this feature to select the throttling mode for TM2. The options are LEM Throttling and Adaptive Throttling.

CPU C-States

C-States architecture, a processor power management platform developed by Intel, can further reduce power consumption from the basic C1 (Halt State) state that blocks clock cycles to the CPU. Select Enabled for CPU C-States support. The options are **Enabled** and Disabled. If this feature is set to Enabled, the following items will display:

Package C-State limit

Select Auto for the AMI BIOS to automatically set the limit on the C-State package register. The options are **No Limit**, C1 State, C2 State, C3 State, C4 State, and C6 (Non Retention) State.

Enhanced Halt State (C1E) (Available when "CPU C-States" is set to Enabled)

Select Enabled to support Enhanced C1 Power State to boost system performance. Please reboot the system for the new setting to take effect. The options are **Disabled** and Enabled.

ACPI C2 (Available when "CPU C-States" is set to Enabled)

Select Enabled for ACPI C2 support to determine how the processor will report the CPU-C state to the operating system. The options are Disabled, **C6 NS**, and C6 FS.

Monitor/Mwait

Select Enabled to implement the Mwait instruction along with the Monitor instruction to allow the processor to specify the location for the BIOS to monitor activities and to issue the instruction to put the operation on hold (Mwait).

L1 Prefetcher (Available when supported by the CPU)

If enabled, the hardware prefetcher will prefetch streams of data and instructions from the main memory to the L1 cache to improve CPU performance. The options are Disabled and **Enabled**.

L2 Prefetcher (Available when supported by the CPU)

If enabled, the hardware prefetcher will prefetch streams of data and instructions from the main memory to the L2 cache to improve CPU performance. The options are Disabled and **Enabled**.

ACPI 3.0 T-States (Available when "CPU C-States" is set to Enabled)

Select Enabled to support ACPI (Advanced Configuration and Power Interface) 3.0 T-States to determine how the processor will report to the operating system during CPU-Throttling states. The options are Enabled and **Disabled**.

Fast String

Select Enabled to enable Fast String support for REP MOVSB/STOSB, which will carry out Repeat-String Operation instructions to move a string of commands to another location (MOVSB) or to add a string of commands to an existing instruction code (STOSB). The options are Disabled and **Enabled**.

Machine Check

Select Enabled to use Intel's machine check mechanism to detect and report hardware (machine) errors. The options are Disabled and **Enabled**.

Max CPUID Value Limit

Use this feature to set the maximum CPU ID value. Enable this feature to boot the legacy operating systems that cannot support processors with extended CPUID functions. The options are Enabled and **Disabled** (for the Windows OS.)

Execute Disable Bit (Available if supported by the OS & the CPU)

Set to Enabled to enable the Execute Disable Bit which will allow the processor to designate areas in the system memory where an application code can execute and where it cannot, thus preventing a worm or a virus from flooding illegal codes to overwhelm the processor and damage the system during an attack. The default is **Enabled**. (Refer to Intel® and Microsoft websites for more information.)

VMX (Available when supported by the CPU)

Select Enabled to enable Intel Vanderpool Technology support which will allow one platform to run multiple operating systems and applications in independent partitions, creating multiple "virtual" systems in one physical computer. The options are **Enabled** and Disabled.

BIST Selection (Available when supported by the CPU)

Select Enabled to set a BIST (Built-In-Self-Test) point selection to enhance system performance. The options are **Disabled** and Enabled.

MTRR (Memory Type Range Register) Default as Uncacheable

If this feature is set to Enabled, the default setting will be set to "Uncacheable" in the Memory-Type-Range Table to protect the data stored in the MTRR table from being cached. The options are **Disabled** and Enabled.

Extended APIC

Select Enabled to enable Extended APIC (Advanced Programmable Interrupt Control) support to enhance power management. The options are **Enabled** and Disabled.

AES-NI

Select Enabled to use the Advanced Encryption Standard in the processor. The options are **Enabled** and Disabled.

PECI Enable

Select Enabled to enable PECI (Platform Environment Control Interface) support, which will enhance CPU thermal management to achieve power efficiency. The options are **Disabled** and Enabled.

PECI Trusted

Select Enabled to support Trusted Platform Environment Control Interface to improve CPU thermal management. The options are **Disabled** and Enabled.

PECI SMBus Speed

Use this feature to set the speed for the physical bus to operate. The options are **Standard (80 kHz)**, Standard (100 kHz), Fast Mode (400 kHz), and Fast Mode Plus (1 MHz).

Turbo (Available if Intel® EIST technology is Enabled)

This feature allows processor cores to run faster than marked frequency in specific conditions. The options are Disabled and **Enabled**.

RAPL

Select Enabled to enable RAPL (Running Average Power Limit) support. Use the keyboard to enter your default setting.

MSR 606 PKG_POWER_SKU_UNIT

Use the keyboard to enter the number of the computer units that are SKU-specific in terms of power, energy, and time are concerned. .

MSR 610 PKG_TURBO_PWR_LIM

Use this feature to specify the processor power consumption limits during short and long duration.

MSR 670 PKG_TURBO_CFG1

Use this feature to specify various parameters of system components such as Turbo, Minimum Energy, SoC TDP Policy, ICMAX Control, and Turbo Mode.

MSR 672_TURBO_WKLD_CFG2

Use this feature to specify ICCMAX Throttle Ratio for C6 Exits when the value of PKG_TURBO_CFG1 [4:3] equals to 10Y.

Active Processor Cores

This feature determines how many CPU cores will be activated for each CPU. When all is selected, all cores in the CPU will be activated. (Please refer to the Intel® web site for more information.) The options are **All**, 1, 2, and 3.

CPU Flex Ratio Override

Select Enabled to support CPU Flex Ratio Programming. The options are **Disabled**, and Enabled.

CPU Core Ratio

Use this feature to set the CPU Core ratio. Use the keyboard to enter the desired value for the CPU core ratio.

► Chipset Configuration

Warning! Setting the wrong values in the following features may cause the system to malfunction.

► North Bridge

The following information will be displayed:

- Memory Information
- MRC Version
- Total Memory
- Memory Frequency

► Pass Gate Setup

Use the following items to configure Pass Gate settings and tests.

Pass Gate Feature Enable

Select Enabled to support Pass Gate features. The options are **Enabled** and Disabled.

2x Refresh Rate

Select Enabled to force the BIOS setup utility to use the x2 refresh rate in Pass-Gate operation regardless the temperatures of the processor and the motherboard. Refresh Rate is the total number of rows needed to refresh the entire DRAM array. x2 Refresh Rate will take 2000 rows of memory to refresh the entire DRAM array. The options are **Disabled** and Enabled.

Pass Gate Stress Test Configuration

Pass Gate Test

Select Enabled to use the Pass Gate test. The options are **Disabled** and Enabled.

Pass Gate Test Direction

This feature specifies how the BIOS setup utility should perform the Pass Gate test (from the lowest memory to the highest or from the highest memory to the lowest.) The options are **Lowest to Highest** and Highest to Lowest.

Pass Gate Test Repetition

Use this feature to specify how many times the Pass Gate test should be performed over the same memory row (x1000). The default setting is **900**.

Pass Gate Test Iterations

Use this feature to specify how many repetitions the Pass Gate test should be performed over the same memory row (refer to the item above). The default setting is **1**.

Pass Gate Test Swizzle (For Samsung Products)

Select Enabled to use the Pass Gate Test Swizzle mode to support Samsung products. Select Auto for the system to automatically switch to the Pass Gate Test Swizzle mode when a Samsung device is detected. The options are **Auto** and Enabled.

Pass Gate Pattern

Use the keyboard to enter the parameter value of the Pass Gate Pattern used for data input. The options are **0's** and **1's**.

Pass Gate Target Pattern

Use the keyboard to enter the target parameter value for the Pass Gate Pattern used for data input. The options are **0's** and **1's**.

Pass Gate Speed

Use this feature to set the Pass Gate speed. The options are Auto and **1x Only**.

Channel 0/Channel 1

Rank 0/Rank 1/Rank 2/Rank 3

Select Enabled to allow the Pass Gate test to be performed on a memory module specified by the user. The options are **Enabled** and Disabled.

Pass Gate MonteCarlo

Select Enabled to enable a algorithm search to find the maximum value of the Pass Gate test. The options are **Disabled** and Enabled.

Pass Gate Maximum Failures

Use this feature to specify the maximum number that Pass Gate failures will be counted for.

Pass Gate Maximum Repetition

Use this feature to specify the number that the Pass Gate tests will be repeated.

Fast Boot

Select Enabled to skip the routine memory procedure and attempt to boot the system using the last valid memory configuration settings at bootup. The options are **Disabled**, and Enabled.

Smm Size (MB)

Use the keyboard to enter a value for the size of the SMM/TSEG region where 1 MB is aligned to.

Force Memory Map Ax

Select Enabled to force the BIOS setup utility to specify the total number of Kb (or an error) of memory errors detected by the BIOS upon OS initialization. The options are **Enabled** and Auto.

Memory Frequency

This feature sets the memory frequency limits for the DIMM modules installed on the the motherboard. The options are **Auto**, DDR3-1333 (MHz), and DDR3-1600 (MHz).

Memory Channels

Use this feature to configure the settings for memory channels. The options are **Auto** and Single Channel.

MRC (Maximal Ratio Combining) Debug Messages

Use this feature to set the debug output display in MRC. The options are Disabled, Minimum, **Medium**, and Maximum.

DDR Voltage

Use this feature to set the DDR3 voltage setting. The default option is **100**.

Fine DDR Voltage

Use this feature to set the fine DDR3 voltage setting. The options are **Auto**, 1.25V, 1.35V, and 1.50V.

CKE Power Down

Select Enabled to enable CKE Power Down support which controls the low power mode for RAM in the active power standby mode. The options are **Enabled**, and Disabled.

ECC (Error Correctable Correction)

Select Enabled to enable ECC support. The options are **Enabled** and Disabled.

Faulty Part Tracking

Select Enabled to support faulty part tracking for the system to keep track of faulty memory parts. The options are **Disabled** and Enabled.

On Correctable Faulty Part

This feature displays the status of "On Correctable Faulty Part".

Patrol Scrub Enable

Patrol Scrubbing is a process that allows the CPU to correct correctable memory errors detected on a memory module and send the correction to the requestor (the original source). When this item is set to Enabled, North Bridge will read and write back one cache line every 16K cycles, if there is no delay caused by internal processing. By using this method, roughly 64 GB of memory behind North Bridge will be scrubbed every day. The options are Disabled and **Enabled**.

Patrol Scrub Period

Use this item to specify how often Patrol Scrubbing should be performed. Select 24 hours to allow Patrol Scrubbing to be performed every 24 hours. The options are **24 hours**, 10 hours, 4 hours, and 1 hour.

Demand Scrub Enable

Demand Scrubbing is a process that allows the CPU to correct correctable memory errors found on a memory module. When the CPU or I/O issues a demand-read command, and the read data from memory turns out to be a correctable error, the error will be corrected and sent to the requestor (the original source). Memory will be updated at the same time. Select Enabled to use Demand Scrubbing for ECC memory correction. The options are **Enabled** and Disabled.

AB Segments In DRAM

When this feature is set to Enabled, Target A- or B- segments will be routed to DRAM during memory read and write cycles. The options are Enabled and **Disabled**.

E Segment In DRAM

When this feature is set to Enabled, Target E segment will be routed to DRAM during memory read and write cycles. The options are **Enabled** and Disabled.

F Segment In DRAM

When this feature is set to Enabled, Target F segment will be routed to DRAM during memory read and write cycles. The options are **Enabled** and Disabled.

ZQ Calibration

When this feature is set to Enabled, commands to calibrate DRAM output drivers will be issued so that ZQ Calibration will be performed during a system boot or system reset. The options are **Enabled** and Disabled.

Rank Margin Tool

Select Enabled to enable Rank Margin Tool support. The options are Enabled and **Disabled**.

CMD Rate (Command Rate)

Use this feature to set the CMD rate, which is the number of clock cycles needed for the memory to send data. The options are **Auto**, 1N, 2N and 3N.

Out-of-Order Memory Processing

Select Enabled to support Out-of-Order Memory Processing, which is a process used by a computer to retrieve instructions from its memory to improve CPU performance. The options are **Enabled** and Disabled.

Out-of-Order Aging Threshold

In a multi-core architecture, the DRAM system in a computer processes multiple threads or streams of requests from the In_Order (FIFO: First_In_First_Out) queue and the Out_of_Order queue in the interleaved/interconnect mode. This feature allows the user to specify the maximum number of requests to be processed for the same order before the system moves on and process the next thread of requests in the "Out_Of_Order" queue while in the "Out_of_Order" cycle. Once the "Out_of_Order" cycle expires, the system will move to the "In_Order" cycle and starts to process the requests in the "In-Order" queue. The default setting is **31**.

New Request Bypass

Select Enabled for the system to skip the process currently in progress and process a new request immediately. The options are **Enabled** and Disabled.

Dynamic Self Refresh

Select Enabled to support Dynamic Self-Refreshing for the onboard memory controller. The options are **Enabled** and Disabled.

PMOP Value for PCO

Use the keyboard to enter the Opcode value for the SPID Power Mode. The default setting is **4**.

PMOP Value for PCX

Use the keyboard to enter the PCX value for the SPID Power Mode. The default setting is **7**.

Per-Bit Margins

Select Enabled to set the "per-bit margins" used in the Maximal Ratio Combining (MRC) technique. The options are **Disabled** and Enabled.

Open Page Policy Timer

Use the feature to set the Page_Closure timer, which will specify how long a DRAM memory page should remain open. The options are Disabled, Immediate, **30-60 ns**, .60-120 ns, 120-240 ns, 240-480 ns, 480-960 ns, and 1-2 us.

Memory Thermal

Select Enabled to support Memory-Thermal-Management. The options are **Disabled** and Enabled.

Memory Scrambler

Select Enabled to enable memory scrambler support for memory error correction. The settings are **Enabled** and Disabled.

Slow Power Down Exit

Select Enabled to use the slow-power-down mode when the system memory exits from the pre-charge state. The settings are **Enabled** and Disabled.

Verf Override Enable

Select Enabled to verify an override command before it is executed. The settings are **Disabled** and Enabled.

► South Bridge**► USB Configuration**

This submenu displays the following sub-items:

- USB Module Version
- USB Devices

Legacy USB Support

This feature enables support for legacy USB devices. Select Auto to disable legacy support if USB devices are not present. Select Disable to have USB devices available only for EFI applications. The options are **Enabled**, Disabled and Auto.

USB 3.0 Support

Select Enabled for onboard USB 3.0 support. The options are **Enabled** and Disabled.

XHCI Hand-Off

This item is a work-around solution for operating systems that do not support XHCI (Extensible Host Controller Interface) hand-off. The XHCI ownership change should be claimed by the XHCI driver. The options are **Enabled** and Disabled.

EHCI Hand-Off

This item is for the Operating Systems that do not support Enhanced Host Controller Interface (EHCI) hand-off. When this item is enabled, EHCI ownership change will be claimed by the EHCI driver. The settings are Enabled and **Disabled**.

USB Mass Storage Driver Support

Select Enabled for USB Mass Storage Driver support. The options are **Enabled** and Disabled.

Port 60/64 Emulation

This feature enables or disables I/O port 60h/64h emulation support. This feature should be enabled for complete USB keyboard legacy support for operating systems that cannot detect the presence of USB devices. The options are **Disabled** and Enabled.

USB Hardware Delays and Time-Out

USB Transfer Time-Out

Use the keyboard to enter the time-out value for USB Control/Bulk/Interrupt transfers. The default setting is **20 seconds**.

Device Reset Time-Out

Use the keyboard to enter time-out value during a USB mass_storage_device reset. The options are **Auto** and Manual.

Device Power-Up Delay

Use the feature to set the maximum time a USB device will wait before reporting itself to the host controller. Select Auto to use the manufacturer's default setting. Select Manual to set the default setting manually. The default setting is **20 seconds**.

► SATA Configuration

When this submenu is selected, the AMI BIOS automatically detects the presence of the SATA Devices and displays the following items:

SATA 3 Controller

This feature allows the user to configure the settings of SATA 3.0 devices

SATA 3 Controller

Select Enabled to enable the onboard SATA 3.0 controller. The options are **Enabled** and Disabled.

SATA Mode

This item sets SATA device mode. The options are IDE and **AHCI**.

LPM (Link Power Management)

Select Enabled to support Link Power Management to improve system power management. The options are Disabled, and **Enabled**.

ALPM (Aggressive Link Power Management)

Select Enabled to support Aggressive Link Power Management to enhance system power performance. The options are Disabled, and **Enabled**.

Overwrite SIR Values

Select Enabled to overwrite SIR values. The options are Enabled, and **Disabled**.

SATA Port 0/SATA Port 1

The submenu below allows the user to configure the following settings for SATA Port 0 or SATA Port 1.

Spin Up

On an edge detect from 0 to 1, use this feature to set a COMRESET initialization sequence for a device. The options are Enabled and **Disabled**.

Hot Plug

This feature designates this port for hot plugging. Set this item to Enabled for hot-plugging support, which will allow the user to replace a SATA drive without shutting down the system. The options are **Enabled** and Disabled.

External Device

Select Enabled for external SATA device support. The options are **Enabled** and Disabled.

Mechanical Switch

Select Enabled for mechanical switch support. The options are **Disabled** and Enabled.

SATA 2 Controller

This feature allows the user to configure the settings of SATA 2.0 devices

SATA Controller

Select Enabled to enable the onboard SATA 2.0 controller on the motherboard. The options are **Enabled** and Disabled.

SATA Mode

This item selects the mode for the installed SATA drives. The options are IDE, and **AHCI**.

LPM (Link Power Management)

Select Enabled to support Link Power Management to improve system power management. The options are Disabled, and **Enabled**.

Aggressive Link Power Management

This feature Enables or Disables Aggressive Link Power Management support for Cougar Point B0 stepping and later. The options are **Enabled** and Disabled.

Overwrite SIR Values

Select Enabled to overwrite SIR values. The options are Enabled, and **Disabled**.

SATA Port 2/SATA Port 3/SATA Port 4/SATA Port 5

The submenu below allows the user to configure the following settings for SATA Port 2, SATA Port 3, SATA Port 4, or SATA Port 5.

Spin Up

On an edge detect from 0 to 1, use this feature to set a COMRESET initialization sequence for a device. The options are Enabled and **Disabled**.

Hot Plug

This feature designates a port specified by a user for hot plugging. Set this item to Enabled for hot-plugging support, which will allow the user to replace a SATA drive without shutting down the system. The options are **Enabled** and Disabled.

External Device

Select Enabled for external SATA device support. The options are **Enabled** and Disabled.

Mechanical Switch

Select Enabled for mechanical switch support. The options are **Disabled** and Enabled.

► PCIe/PCI/PnP Configuration

PCI Latency Timer

Use this feature to set the latency Timer of each PCI device installed on a PCI bus. Select 32 to set the PCI latency to 32 PCI clock cycles. The options are **32 PCI Bus Clocks**, 64 PCI Bus Clocks, 96 PCI Bus Clocks, 128 PCI Bus Clocks, 160 PCI Bus Clocks, 192 PCI Bus Clocks, 224 PCI Bus Clocks and 248 PCI Bus Clocks.

VGA Palette Snoop

Select Enabled to support VGA palette register snooping which will allow the PCI cards that do not contain their own VGA color palettes to examine the video cards palette to mimic it for proper color display. The options are **Disabled** and Enabled.

PERR# Generation

Select Enabled to allow a PCI device to generate a PERR number for a PCI Bus Signal Error Event. The options are **Disabled** and Enabled.

SERR# Generation

Select Enabled to allow a PCI device to generate an SERR number for a PCI Bus Signal Error Event. The options are **Enabled** and Disabled.

System Error Logging

If this item is set to enabled, an error log will be created when a system error occurs. The options are Enabled and **Disabled**.

Maximum Payload

Select Auto to allow the system BIOS to automatically set the maximum payload value for a PCI-E device to enhance system performance. The options are **Auto**, 128 Bytes, 256 Bytes, 512 Bytes, 1024 Bytes, 2048 Bytes, and 4096 Bytes.

Maximum Read Request

Select Auto to allow the system BIOS to automatically set the maximum Read Request size for a PCI-E device to enhance system performance. The options are **Auto**, 128 Bytes, 256 Bytes, 512 Bytes, 1024 Bytes, 2048 Bytes, and 4096 Bytes.

ASPM Support

This feature allows the user to set the Active State Power Management (ASPM) level for a PCI-E device. Select Force L0 to force all PCI-E links to operate at L0 state. Select Auto to allow the system BIOS to automatically set the ASPM level for the system. Select Disabled to disable ASPM support. The options are **Disabled**, Force L0, and Auto.

Warning: Enabling ASPM support may cause some PCI-E devices to fail!

Above 4G Decoding (Available if the system supports 64-bit PCI decoding)

Select Enabled to decode a 64-bit PCI device in the space above 4G Address. The options are Enabled and **Disabled**.

Launch Storage OPROM Policy

This feature controls how the system executes UEFI (Unified Extensible Firmware Interface), and legacy storage OPROM. Select Legacy Only to boot the system using a legacy storage device. The options are Do Not Use, UEFI Only **Legacy Only**, Legacy First, UEFI First.

PCIe Slot 1 OPROM

Select Enabled to enable Option ROM support to boot the computer using a network interface device install in the slot specified above. The options are **Enabled** and Disabled.

Launch Video OPROM Policy

This feature controls how the system executes UEFI (Unified Extensible Firmware Interface) and video device OPROM. Select Legacy Only to boot the system using a legacy device installed in a video port. The options are Do Not Use, UEFI Only **Legacy Only**, Legacy First, UEFI First.

VGA Priority

This feature allows the user to select the graphics adapter to be used as the primary boot device. The options are **Onboard**, and Offboard.

Launch Network OPROM Policy

This feature controls how the system executes UEFI (Unified Extensible Firmware Interface) and LAN device OPROM. Select Legacy Only to boot the system using a legacy device installed in a LAN port. The options are Do Not Use, UEFI Only **Legacy Only**, Legacy First, UEFI First.

Onboard LAN Option ROM Select

Select iSCSI to use the iSCSI Option ROM to boot the computer using a network device. Select PXE (Preboot Execution Environment) to use an PXE Option ROM to boot the computer using a network device. The options are iSCSI and **PXE**.

Load Onboard LAN1 Option ROM/Load Onboard LAN2 Option ROM/Load Onboard LAN3 Option ROM/Load Onboard LAN4 Option ROM

Select Enabled to enable the onboard LAN1 Option ROM~LAN4 Option ROM. This is to boot the computer using a network device. The default setting for LAN1 Option ROM is **Enabled**, and the default settings for LAN2 Option ROM/LAN3 Option ROM/LAN4 Option ROM are **Disabled**.

►ACPI Settings

High Precision Event Timer

Select Enabled to activate the High Performance Event Timer (HPET) that produces periodic interrupts at a much higher frequency than a Real-time Clock (RTC) does in synchronizing multimedia streams, providing smooth playback and reducing the dependency on other timestamp calculation devices, such as an x86 RDTSC Instruction embedded in the CPU. The High Performance Event Timer is used to replace the 8254 Programmable Interval Timer. The options are **Enabled** and Disabled.

WHEA Support

This feature Enables the Windows Hardware Error Architecture (WHEA) support for the Windows 2008 (or a later vision) operating system. The options are **Enabled** and Disabled.

► Trusted Computing Configuration (Available when a TPM Device is Detected and TPM Jumper is Enabled)

Configuration

Security Device Support

Select Enable for the AMI BIOS to automatically download the drivers needed to provide Trusted Computing platform support for this machine to ensure data integrity and network security. The options are **Disable** and Enable.

TPM State

Select Enabled to use TPM (Trusted Platform Module) settings for system data security. The options are Disabled and **Enabled**.

Note: The system will reboot for the change on TPM State to take effect.

Pending Operation

Use this item to schedule a TPM-related operation to be performed by a security device for TPM support. The options are **None**, Enable Take Ownership, Disable Take Ownership, and TPM Clear.

Note: The computer will reboot to carry out a pending TPM operation and change TPM state for a TPM device.

Current Status Information

This feature indicates the status of the following TPM items:

TPM Enabled Status

TPM Active Status

TPM Owner Status

► Super IO Configuration

Super IO Chip AST2400

► Serial Port 0 Configuration /Serial Port 1 Configuration

This submenu allows the user the configure settings of Serial Port 1 or Serial Port 2.

Serial Port

Select Enabled to enable the a selected onboard serial port. The options are **Enabled** and Disabled.

Device Settings

This item displays the status of a serial part specified by the user.

Change Settings

This feature specifies the base I/O port address and the Interrupt Request address of a serial port specified by the user. Select **Auto** to allow the BIOS to automatically assign the base I/O and IRQ address.

The options for Serial Port 1 are **Auto**, (IO=3F8h; IRQ=4), (IO=3F8h; IRQ=3, 4, 5, 6, 7, 9, 10, 11, 12), (IO=2F8h; IRQ=3, 4, 5, 6, 7, 9, 10, 11, 12), (IO=3E8h; IRQ=3, 4, 5, 6, 7, 9, 10, 11, 12) and (IO=2E8h; IRQ=3, 4, 5, 6, 7, 9, 10, 11, 12).

The options for Serial Port 2 are **Auto**, (IO=2F8h; IRQ=3), (IO=3F8h; IRQ=3, 4, 5, 6, 7, 9, 10, 11, 12), (IO=2F8h; IRQ=3, 4, 5, 6, 7, 9, 10, 11, 12), (IO=3E8h; IRQ=3, 4, 5, 6, 7, 9, 10, 11, 12) and (IO=2E8h; IRQ=3, 4, 5, 6, 7, 9, 10, 11, 12).

Device Mode

Use this feature to set the optimal setting for a super I/O device. The options are **24MHz/13** and 24MHz.

Serial Port 2 Attribute (Available for Serial Port 2 only)

This feature specifies the attribute of Serial Port 2. The options are **SOL** and **COM**.

► Serial Port Console Redirection

COM1 Console Redirection, COM2/SOL Console Redirection

Console Redirection

Select **Enabled** to enable console redirection support for a serial port specified by the user. The options are **Enabled** and **Disabled**.

► Console Redirection Settings

This feature allows the user to specify how the host computer will exchange data with the client computer, which is the remote computer used by the user.

Terminal Type

This feature allows the user to select the target terminal emulation type for Console Redirection. Select **VT100** to use the ASCII Character set. Select **VT100+** to add color and function key support. Select **ANSI** to use the Extended ASCII Character Set. Select **VT-UTF8** to use UTF8 encoding to map Unicode characters into one or more bytes. The options are **ANSI**, **VT100**, **VT100+**, and **VT-UTF8**.

Bits Per second

Use this feature to set the transmission speed for a serial port used in Console Redirection. Make sure that the same speed is used in the host computer and the client computer. A lower transmission speed may be required for long and busy lines. The options are 9600, 19200, 38400, 57600 and **115200** (bits per second).

Data Bits

Use this feature to set the data transmission size for Console Redirection. The options are 7 Bits and **8 Bits**.

Parity

A parity bit can be sent along with regular data bits to detect data transmission errors. Select Even if the parity bit is set to 0, and the number of 1's in data bits is even. Select Odd if the parity bit is set to 0, and the number of 1's in data bits is odd. Select None if you do not want to send a parity bit with your data bits in transmission. Select Mark to add a mark as a parity bit to be sent along with the data bits. Select Space to add a Space as a parity bit to be sent with your data bits. The options are **None**, Even, Odd, Mark and Space.

Stop Bits

A stop bit indicates the end of a serial data packet. Select 1 Stop Bit for standard serial data communication. Select 2 Stop Bits if slower devices are used. The options are **1** and 2.

Flow Control

Use this feature to set the flow control for Console Redirection to prevent data loss caused by buffer overflow. Send a "Stop" signal to stop sending data when the receiving buffer is full. Send a "Start" signal to start sending data when the receiving buffer is empty. The options are **None** and Hardware RTS/CTS.

VT-UTF8 Combo Key Support

Select Enabled to enable VT-UTF8 Combination Key support for ANSI/VT100 terminals. The options are **Enabled** and Disabled.

Recorder Mode

Select Enabled to capture the data displayed on a terminal and send it as text messages to a remote server. The options are **Disabled** and Enabled.

Resolution 100x31

Select Enabled for extended-terminal resolution support. The options are Disabled and **Enabled**.

Legacy OS Redirection Resolution

Use this feature to select the number of rows and columns used in Console Redirection for legacy OS support. The options are 80x24 and **80x25**.

Putty KeyPad

This feature selects the settings for Function Keys and KeyPad used for Putty, which is a terminal emulator designed for the Windows OS. The options are **VT100**, LINUX, XTERMR6, SC0, ESCN, and VT400.

Redirection After BIOS Post

Use this feature to enable or disable legacy console redirection after BIOS POST. When set to Bootloader, legacy console redirection is disabled before booting the OS. When set to Always Enable, legacy console redirection remains enabled when booting the OS. The options are **Always Enable** and Bootloader.

Serial Port for Out-of-Band Management/Windows Emergency Management Services (EMS)

The submenu allows the user to configure Console Redirection settings to support Out-of-Band Serial Port management.

Console Redirection (for EMS)

Select Enabled to use a COM Port selected by the user for Console Redirection. The options are Enabled and **Disabled**.

► Console Redirection Settings (for EMS)

This feature allows the user to specify how the host computer will exchange data with the client computer, which is the remote computer used by the user.

Out-of-Band Management Port

The feature selects a serial port used by the Microsoft Windows Emergency Management Services (EMS) to communicate with a remote server. The options are **COM1 Console Redirection** and COM2/SOL Console Redirection.

Terminal Type

This feature allows the user to select the target terminal emulation type for Console Redirection. Select VT100 to use the ASCII character set. Select VT100+ to add color and function key support. Select ANSI to use the extended ASCII character set. Select VT-UTF8 to use UTF8 encoding to map Unicode characters into one or more bytes. The options are ANSI, VT100, VT100+, and **VT-UTF8**.

Bits Per Second

This item sets the transmission speed for a serial port used in Console Redirection. Make sure that the same speed is used in the host computer and the client computer. A lower transmission speed may be required for long and busy lines. The options are 9600, 19200, 57600, and **115200** (bits per second).

Flow Control

This feature allows the user to set the flow control for Console Redirection to prevent data loss caused by buffer overflow. Send a "Stop" signal to stop sending data when the receiving buffer is full. Send a "Start" signal to start sending data when the receiving buffer is empty. The options are **None**, Hardware RTS/CTS, and Software Xon/Xoff.

Data Bits, Parity, Stop Bits

The status of each item above is displayed.

7-4 Event Logs

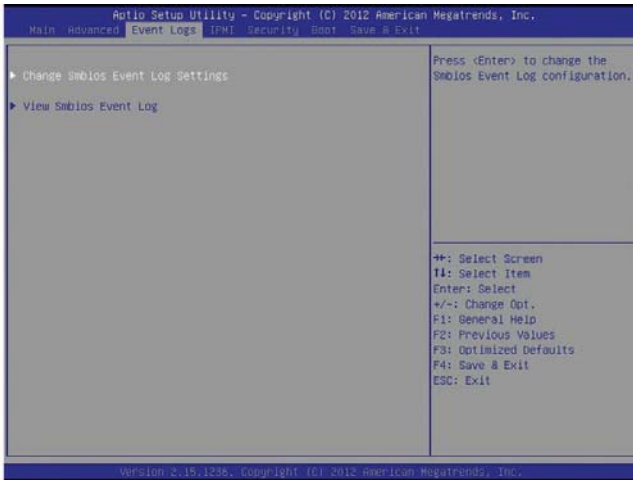

► Change SMBIOS Event Log Settings

Enabling/Disabling Options

SMBIOS Event Log

Change this item to enable or disable all features of the SMBIOS Event Logging during system boot. The options are **Enabled** and Disabled.

Erasing Settings

Erase Event Log

If No is selected, data stored in the event log will not be erased. Select Yes, Next Reset, data in the event log will be erased upon next system reboot. Select Yes, Every Reset, data in the event log will be erased upon every system reboot. The options are **No**, Yes, Next reset, and Yes, Every reset.

When Log is Full

Select Erase Immediately for all messages to be automatically erased from the event log when the event log memory is full. The options are **Do Nothing** and Erase Immediately.

SMBIOS Event Long Standard Settings

Log System Boot Event

This option toggles the System Boot Event logging to enabled or disabled. The options are **Disabled** and Enabled.

MECI

The Multiple Event Count Increment (MECI) counter counts the number of occurrences that a duplicate event must happen before the MECI counter is incremented. This is a numeric value. The default value is **1**.

METW

The Multiple Event Time Window (METW) defines number of minutes must pass between duplicate log events before MECI is incremented. This is in minutes, from 0 to 99. The default value is **60**.

Customer Options

Log OEM Codes

Select Enabled to log the status of OEM EFI codes. The options are **Enabled** and Disabled.

Convert OEM Codes

Select Enabled to convert the OEM Status codes to the standard SMBIOS codes. The options are Enabled and **Disabled**.

►View SMBIOS Event Log

This section displays the contents of the SMBIOS Event Log.

7-5 IPMI

Use this feature to configure Intelligent Platform Management Interface (IPMI) settings.

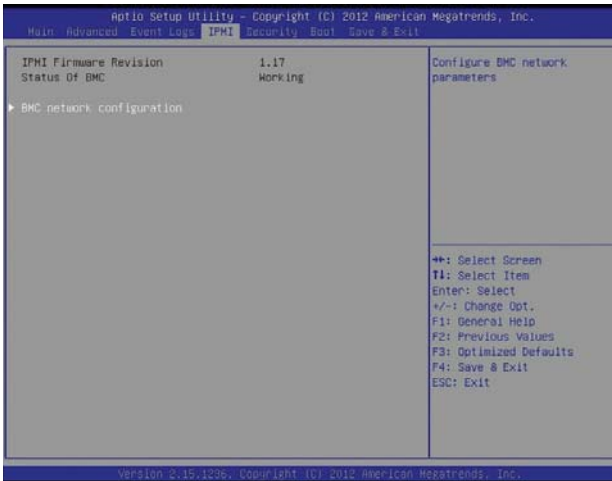

IPMI Firmware Revision

This item indicates the IPMI firmware revision used in your system.

Status BMC (Baseboard Management Cont

This item indicates the status of the IPMI firmware installed in your system.

► BMC Network Configuration

BMC Network Congifuration

LAN Channel 1: This feature allows the user to configure the setting for LAN Port 1.

Configuration Address Source

This feature allows the user to select the source of the IP address for this computer. If Static is selected, you will need to know the IP address of this computer and enter it to the system manually in the field. If DHCP is selected, the BIOS will search for a DHCP (Dynamic Host Configuration Protocol) server in the network that is attached to and request the next available IP address for this computer. The options are **DHCP** and Static. The following items are assigned IP addresses automatically if DHCP is selected.

Station IP Address

This item displays the Station IP address for this computer. This should be in decimal and in dotted quad form (i.e., 192.168.10.253).

Subnet Mask

This item displays the sub-network that this computer belongs to. The value of each three-digit number separated by dots should not exceed 255.

Station MAC Address

This item displays the Station MAC address for this computer. Mac addresses are 6 two-digit hexadecimal numbers.

Router IP Address

This item displays the Router IP address for this computer. This should be in decimal and in dotted quad form (i.e., 192.168.10.253).

Router MAC Address

This item displays the Router MAC address for this computer. Mac addresses are 6 two-digit hexadecimal numbers.

7-6 Security Settings

This menu allows the user to configure the following security settings for the system.

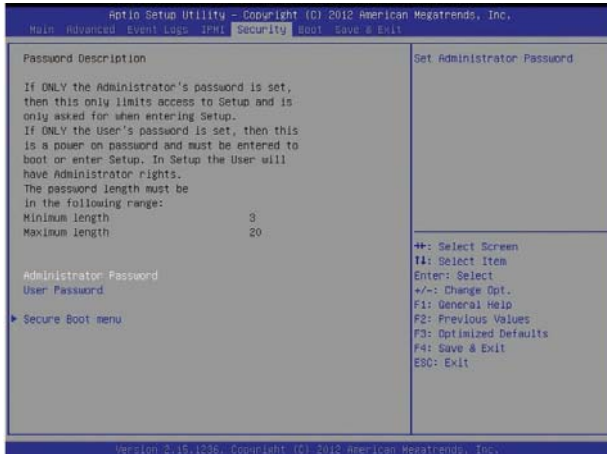

- If the Administrator password is defined ONLY - this controls access to the BIOS setup ONLY.
- If the User's password is defined ONLY - this password will need to be entered upon each system boot, and will also have Administrator rights in the setup.
- Passwords must be at least 3 and up to 20 characters long.

Administrator Password

Press Enter to create a new, or change an existing Administrator password.

User Password

Use this feature to set a User Password which is required to log into the system and to enter the BIOS setup utility. The length of the password should be from 3 characters to 20 characters long.

► Secure Boot Menu

This section displays the contents of the following secure boot features:

- System Mode
- Secure Boot

Secure Boot Mode

Use this item to select the secure boot mode. The options are **Standard** and **Custom**.

►Key Management

This submenu allows the user to configure the following Key Management settings.

Factory Default Key Provision

Select Enabled to install the default Secure-Boot keys set by the manufacturer. The options are **Disabled** and Enabled.

►Enroll All Factory Default Keys

Select Yes to install all default secure keys set by the manufacturer. The options are **Yes** and No.

Save All Secure Boot Variables

This feature allows the user to decide if all secure boot variables should be saved.

Platform Key (PK)

This feature allows the user to configure the settings of the platform keys.

Delete PK (Platform Keys)

This feature allows the user to configure the settings for platform keys deletion.

►Set New PK (Platform Keys)

Select Yes to load the new platform keys from the manufacturer's defaults. Select No to load the platform keys from a file. The options are **Yes** and No.

Key Exchange Key DataBase (KEK)

►Save Key Exchange Key DataBase (KEK)

Select Yes to load the KEK from the manufacturer's defaults. Select No to load the KEK from a file. The options are **Yes** and No.

►Append Key Exchange Key (KEK)

Select Yes to add the KEK from the manufacturer's defaults list to the existing KEK. Select No to load the KEK from a file. The options are **Yes** and No.

Authorized Signature Database (DB)

►Set New DB

Select Yes to load the database from the manufacturer's defaults. Select No to load the DB from a file. The options are **Yes** and No.

► Append DB

Select Yes to add the database from the manufacturer's defaults to the existing DB. Select No to load the DB from a file. The options are **Yes** and No.

Forbidden Signature Database (DBX)**► Set New DBX**

Select Yes to load the DBX from the manufacturer's defaults. Select No to load the DBX from a file. The options are **Yes** and No.

► Append DBX

Select Yes to add the DBX from the manufacturer's defaults to the existing DBX. Select No to load the DBX from a file. The options are **Yes** and No.

► Image Execution Policy

This submenu allows the user to configure the following settings for the Image Execution Policy.

Internal FV

This feature allows the user to set the Image Execution policy for each device path when a security violation occurs. The default setting is **Always Execute**.

Option ROM

This feature allows the user to set the Option ROM Execution policy for each device path when a security violation occurs. The default setting is **Deny Execute**.

Removable Media

This feature allows the user to set the Removable Media Execution policy for each device path when a security violation occurs. The default setting is **Deny Execute**.

Fixed Media

This feature allows the user to set the Fixed Media Execution policy for each device path when a security violation occurs. The default setting is **Deny Execute**.

7-7 Boot Settings

Use this feature to configure Boot Settings:



Boot Option Priorities

This option prioritizes the order of bootable devices that the system to boot from. Press [ENTER] on each entry from top to bottom to select devices.

- Boot Option #1
- Boot Option #2

7-8 Save & Exit

Select the Exit tab from the BIOS setup utility screen to enter the Exit BIOS Setup screen.

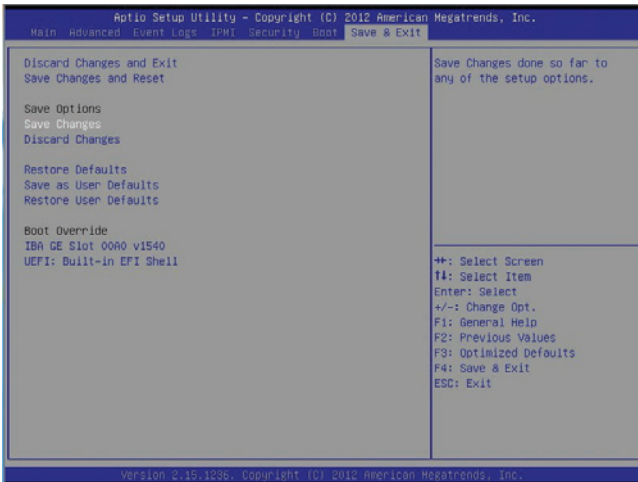

Discard Changes and Exit

Select this option to quit the BIOS Setup without making any permanent changes to the system configuration, and reboot the computer. Select Discard Changes and Exit from the Exit menu and press <Enter>.

Save Changes and Reset

When you have completed the system configuration changes, select this option to leave the BIOS setup utility and reboot the computer, so the new system configuration parameters can take effect. Select Save Changes and Exit from the Exit menu and press <Enter>.

Save Options

Save Changes

After completing the system configuration changes, select this option to save the changes you have made. This will not reset (reboot) the system.

Discard Changes

Select this option and press <Enter> to discard all the changes and return to the AMI BIOS utility Program.

Restore Defaults

To set this feature, select Restore Defaults from the Save & Exit menu and press <Enter>. These are factory settings designed for maximum system stability, but not for maximum performance.

Save As User Defaults

To set this feature, select Save as User Defaults from the Exit menu and press <Enter>. This enables the user to save any changes to the BIOS setup for future use.

Restore User Defaults

To set this feature, select Restore User Defaults from the Exit menu and press <Enter>. Use this feature to retrieve user-defined settings that were saved previously.

Boot Override

Listed on this section are other boot options for the system (i.e., Built-in EFI shell). Select an option and press <Enter>. Your system will boot to the selected boot option.

Appendix A

BIOS POST Error Codes

During the POST (Power-On Self-Test) routines, which are performed each time the system is powered on, errors may occur.

Non-fatal errors are those which, in most cases, allow the system to continue the boot-up process. The error messages normally appear on the screen.

Fatal errors will not allow the system to continue the boot-up procedure. If a fatal error occurs, you should consult with your system manufacturer for possible repairs.

BIOS POST Error Codes		
Beep Code	Error Message	Description
1 beep	Refresh	Circuits have been reset. (Ready to power up)
5 short beeps + 1 long beep	Memory error	No memory detected in the system
1 long beep + 8 short beeps	Display memory read/write error or no video	No video display, video adapter missing or with faulty memory
Continuous high (pitch) + low (pitch)	System Overheat	System overheat

Notes

Appendix B

System Specifications

Processors

One Intel Atom C2758 Tri-Gate, SoC processor

BIOS

64Mb SPI Flash EEPROM with AMI UEFI BIOS

Memory

Support up to 64 GB of unbuffered ECC UDIMM DDR3 SDRAM memory at 1600/1333 MHz speeds, in eight (8) slots, and in either 2, 4, 8, or 16 GB size SODIMMs.

SATA Controller

Two SATA3 (6Gbps) ports and four SATA2 (3Gbps) ports.

Drives

Supports up to four 3.5" hot-swap SAS/SATA drives using a backplane with SES2 and two 2.5" fixed internal drives, and also supports one slim DVD drive

Expansion Slots

One low profile PCI Express 2.0 x8 card

Motherboard

A1SRi-2358F (mini-ITX form factor)

Dimensions: 6.75" x 6.75" (171.45mm x 171.45mm)

Chassis

SC504-203B (1U rackmount)

Dimensions: (WxHxD) 17.2 x 1.7 x 9.8 in. (437 x 43 x 249 mm)

Weight

8 lbs. (3.62 kg.)

System Input Requirements

AC Input Voltage: 100 - 240V AC auto-range

Rated Input Current: 2.6A max

Rated Input Frequency: 50 to 60 Hz

Power Supply

Rated Output Power: 200W (Part# PWS-203-1H)

Rated Output Voltages: +5V (8A), +12V (16A), +3.3V (8A), +5Vsb (2A)

Operating Environment

Operating Temperature: 10° to 35° C (50° to 95° F)

Non-operating Temperature: -40° to 70° C (-40° to 158° F)

Operating Relative Humidity: 8% to 90% (non-condensing)

Non-operating Relative Humidity: 5% to 95% (non-condensing)

Regulatory Compliance

Electromagnetic Emissions: FCC Class B, EN 55022 Class B, EN 61000-3-2/-3-3, CISPR 22 Class B

Electromagnetic Immunity: EN 55024/CISPR 24, (EN 61000-4-2, EN 61000-4-3, EN 61000-4-4, EN 61000-4-5, EN 61000-4-6, EN 61000-4-8, EN 61000-4-11)

Safety: CSA/EN/IEC/UL 60950-1 Compliant, UL or CSA Listed (USA and Canada), CE Marking (Europe)

California Best Management Practices Regulations for Perchlorate Materials: This Perchlorate warning applies only to products containing CR (Manganese Dioxide) Lithium coin cells. "Perchlorate Material-special handling may apply. See www.dtsc.ca.gov/hazardouswaste/perchlorate"

Notes

(continued from front)

The products sold by Supermicro are not intended for and will not be used in life support systems, medical equipment, nuclear facilities or systems, aircraft, aircraft devices, aircraft/emergency communication devices or other critical systems whose failure to perform be reasonably expected to result in significant injury or loss of life or catastrophic property damage. Accordingly, Supermicro disclaims any and all liability, and should buyer use or sell such products for use in such ultra-hazardous applications, it does so entirely at its own risk. Furthermore, buyer agrees to fully indemnify, defend and hold Supermicro harmless for and against any and all claims, demands, actions, litigation, and proceedings of any kind arising out of or related to such ultra-hazardous use or sale.