



# SC-P5000 Series

# User's Guide

---

---

CMP0089-00 EN

## Copyrights and Trademarks

---

### **Copyrights and Trademarks**

No part of this publication may be reproduced, stored in a retrieval system, or transmitted in any form or by any means, electronic, mechanical, photocopying, recording, or otherwise, without the prior written permission of Seiko Epson Corporation. The information contained herein is designed only for use with this Epson printer. Epson is not responsible for any use of this information as applied to other printers.

Neither Seiko Epson Corporation nor its affiliates shall be liable to the purchaser of this product or third parties for damages, losses, costs, or expenses incurred by the purchaser or third parties as a result of accident, misuse, or abuse of this product or unauthorized modifications, repairs, or alterations to this product, or (excluding the U.S.) failure to strictly comply with Seiko Epson Corporation's operating and maintenance instructions.

Seiko Epson Corporation shall not be liable for any damages or problems arising from the use of any options or any consumable products other than those designated as Original Epson Products or Epson Approved Products by Seiko Epson Corporation.

Seiko Epson Corporation shall not be held liable for any damage resulting from electromagnetic interference that occurs from the use of any interface cables other than those designated as Epson Approved Products by Seiko Epson Corporation.

EPSON®, Epson UltraChrome®, SpectroProofer®, EPSON EXCEED YOUR VISION, EXCEED YOUR VISION and their logos are registered trademarks or trademarks of the Seiko Epson Corporation.

Microsoft®, Windows®, Windows Vista® and PowerPoint® are registered trademarks of Microsoft Corporation.

Apple®, Macintosh®, and Mac OS® are registered trademarks of Apple Inc.

Intel® is a registered trademark of Intel Corporation.

PowerPC® is a registered trademark of International Business Machines Corporation.

Adobe®, Photoshop®, Lightroom®, and Adobe® RGB (1998) are either registered trademarks or trademarks of Adobe Systems Incorporated in the United States and/or other countries.

*General Notice: Other product names used herein are for identification purposes only and may be trademarks of their respective owners. Epson disclaims any and all rights in those marks.*

© 2016 Seiko Epson Corporation. All rights reserved.

## Contents

### Copyrights and Trademarks

### Introduction

Important Safety Instructions. . . . .	6
The symbols on the product. . . . .	6
Notes on Installing. . . . .	6
Notes on Handling. . . . .	7
Notes on the Power Supply. . . . .	8
Notes on Consumables (Ink, Media, and so on) . . . . .	9
Other Notes. . . . .	9
Notes on Manuals. . . . .	10
Meaning of Symbols. . . . .	10
Manual Organization. . . . .	10
Opening and Viewing Manuals. . . . .	10
Operating System Versions. . . . .	10
Printer Parts. . . . .	11
Front. . . . .	11
Rear/Spindle. . . . .	14
Control panel. . . . .	16
Screen View. . . . .	18
Features. . . . .	20
Realizing High Resolution. . . . .	20
Realizing High Productivity. . . . .	20
Superior Ease of Use. . . . .	21
Notes on Usage and Storage. . . . .	22
Installation space. . . . .	22
Notes when using the printer. . . . .	22
Notes when not using the printer. . . . .	22
Notes on handling ink cartridges. . . . .	23
Notes on handling paper. . . . .	23
Introducing the Software. . . . .	25
Software on the Disc. . . . .	25
Software on the Website. . . . .	27
Starting and Closing Software. . . . .	28
Starting. . . . .	28
Closing. . . . .	28
Uninstalling Software. . . . .	28
Windows. . . . .	28
Mac OS X. . . . .	29

### Basic Operations

Loading and Removing the Roll Paper. . . . .	30
Printing and Reading Roll Paper Information . . . . .	30

Setting Auto Roll Paper Feeding. . . . .	31
Loading Roll Paper. . . . .	31
Cutting the roll paper. . . . .	36
Removing Roll Paper. . . . .	36
Loading Cut Sheets. . . . .	38
Loading the Paper Cassette. . . . .	39
Loading Manually from the Rear. . . . .	44
Loading and Ejecting Thick Paper. . . . .	46
Basic Printing Methods. . . . .	48
Printing (Windows). . . . .	48
Printing (Mac OS X). . . . .	49
Canceling Printing (Windows). . . . .	51
Canceling Printing (Mac OS X). . . . .	51
Canceling Printing (from the Printer). . . . .	51
Printable area. . . . .	52
Roll Paper Printable Area. . . . .	52
Cut Sheets Printable Area. . . . .	52
Changing the Type of Black Ink. . . . .	53
Switching Automatically. . . . .	53
Switching Manually. . . . .	54
Power Saving Settings. . . . .	55

### Using the Printer Driver(Windows)

Displaying the Settings Screen. . . . .	56
From the Control Panel. . . . .	56
Displaying Help. . . . .	57
Click the Help Button to Display. . . . .	57
Right-click on the item you want to check and display. . . . .	57
Customizing the Printer Driver. . . . .	58
Saving various settings as your Select Settings . . . . .	58
Adding a Paper Type. . . . .	58
Rearranging display items. . . . .	59
Summary of the Utility Tab. . . . .	61

### Using the Printer Driver(Mac OS X)

Displaying the Settings Screen. . . . .	63
Displaying Help. . . . .	63
Using Presets. . . . .	63
Saving to Presets. . . . .	63
Deleting from Presets. . . . .	64
Using Epson Printer Utility 4. . . . .	64
Starting Epson Printer Utility 4. . . . .	64

## Contents

Epson Printer Utility 4 Functions. . . . .	64
--------------------------------------------	----

### Printing Varieties

Auto Color Adjustment by PhotoEnhance (Windows Only). . . . .	66
Correct color and print. . . . .	67
Printing Black and White Photos. . . . .	70
Borderless Printing. . . . .	73
Types of Borderless Printing Methods. . . . .	73
Supported Media Sizes for Borderless Printing . . . . .	74
About Roll Paper Cutting. . . . .	75
Setting Procedures for Printing. . . . .	76
Enlarged/Reduced Printing. . . . .	78
Fit to Page/Scale to fit paper size. . . . .	79
Fit to Roll Paper Width(Windows Only). . . . .	80
Custom Scale Setting. . . . .	80
Multi-Page Printing. . . . .	82
Manual Double-Sided Printing(Windows Only) . . . . .	83
Cautions when Performing Double-Sided Printing. . . . .	83
Setting Procedures for Printing. . . . .	84
Poster Printing (Enlarge to cover several sheets and print - Windows only). . . . .	85
Setting Procedures for Printing. . . . .	85
Joining the output paper together. . . . .	87
Printing at Non-Standard Sizes. . . . .	90
Banner printing (on roll paper). . . . .	92
Layout Manager(Windows Only). . . . .	94
Setting Procedures for Printing. . . . .	95
Saving and Recalling Settings. . . . .	96

### Color Management Printing

About Color Management. . . . .	98
Color Management Print Settings. . . . .	98
Setting profiles. . . . .	99
Setting color management with the applications . . . . .	99
Setting color management with the printer driver . . . . .	101
Color management printing by Host ICM (Windows). . . . .	101
Color management printing by ColorSync (Mac OS X). . . . .	102
Color management printing by Driver ICM(Windows Only). . . . .	102

### Using the Control Panel Menu

Menu Operations. . . . .	105
Menu List. . . . .	106
Maintenance menu. . . . .	106
Paper menu. . . . .	106
Printer Setup Menu. . . . .	108
Printer Status Menu. . . . .	108
SpectroProofer Menu. . . . .	109
Network Setup Menu. . . . .	109
Preferences Menu. . . . .	109
Administrator Menu. . . . .	110
Menu Descriptions. . . . .	111
Maintenance. . . . .	111
Paper. . . . .	113
Printer Setup. . . . .	117
Printer Status. . . . .	118
SpectroProofer. . . . .	119
Network Setup. . . . .	119
Preferences. . . . .	120
Administrator Menu. . . . .	121

### Maintenance

Print Head Maintenance. . . . .	122
Maintenance Operations. . . . .	122
Checking for clogged nozzles. . . . .	123
Cleaning the print head. . . . .	124
Adjusting print misalignments (Head Alignment). . . . .	126
Replacing Consumables. . . . .	130
Replacing Ink Cartridges. . . . .	130
Replacing Maintenance Box 1 and 2. . . . .	132
Replacing the Cutter. . . . .	134
Cleaning the Printer. . . . .	137
Cleaning the outside. . . . .	137
Cleaning the inside. . . . .	137

### Problem Solver

What to do When a Message is Displayed. . . . .	141
When a Maintenance Call/Service Call Occurs. . . . .	148
Troubleshooting. . . . .	150
You cannot print (because the printer does not work). . . . .	150
The printer sounds like it is printing, but nothing prints. . . . .	152
The prints are not what you expected. . . . .	152
Feeding or ejecting problems. . . . .	156
Others. . . . .	158

## Contents

### **Appendix**

Options and Consumable Products. . . . .	161
Supported Media. . . . .	163
Epson Special Media Table. . . . .	163
Supported Commercially Available Paper. . . . .	173
Before Printing on Commercially Available Paper. . . . .	174
Notes When Moving or Transporting the Printer . . . . .	177
Before Moving or Transporting. . . . .	177
Notes on Transporting. . . . .	177
After Moving or Transporting. . . . .	177
System Requirements. . . . .	178
Specifications Table. . . . .	179
Information of EU Declaration of Conformity . . . . .	180

### **Where To Get Help**

Technical Support Web Site. . . . .	181
Contacting Epson Support. . . . .	181
Before Contacting Epson. . . . .	181
Help for Users in North America. . . . .	182
Help for Users in Europe. . . . .	182
Help for Users in Australia. . . . .	182
Help for Users in Singapore. . . . .	183
Help for Users in Thailand. . . . .	183
Help for Users in Vietnam. . . . .	183
Help for Users in Indonesia. . . . .	183
Help for Users in Hong Kong. . . . .	184
Help for Users in Malaysia. . . . .	184
Help for Users in India. . . . .	184
Help for Users in the Philippines. . . . .	185

### **Software License Terms**

Open Source Software Licenses. . . . .	186
Bonjour. . . . .	186
Other Software Licenses. . . . .	191
Info-ZIP copyright and license. . . . .	191

---

# Introduction

---

## Important Safety Instructions

Read all of these instructions before using the printer. Also be sure to follow all warnings and instructions marked on the printer.

### For Users in Europe

**Warning:**

This is a class A product. In a domestic environment this product may cause radio interference in which case the user may be required to take adequate measures.

---

## The symbols on the product

The symbols on this Epson product are used in order to ensure safety and proper use of the product and to prevent danger to customers and other persons, and property damage.

The symbols indicate the meaning below. Be sure that you completely understand the meaning of symbols on this product before using it.



Stand-by



Alternating current

---

## Notes on Installing

**Warning****Do not obstruct the vents on the product.**

If the vents are obstructed, the internal temperature could rise and cause a fire. Do not cover the printer with a cloth or install it in a location with poor ventilation. Make sure you secure sufficient space for the installation as described in the manual.

 *Setup Guide*

**Caution****Do not install or store the printer in an unstable location or a location subject to vibrations from other equipment.**

The printer could fall or tip over and cause an injury.

**Do not install the printer in locations subject to oily smoke and dust, or in locations subject to humidity or where it could easily get wet.**

An electric shock or fire could occur.

**Do not tilt the product more than 10 degrees forward, back, left, or right while moving it.**

Failure to observe this precaution could result in the printer falling over, causing accidents.

## Introduction

**Caution****Because the product is heavy, it should not be carried by one person.**

Two people are needed to unpack or carry the printer. See the following for details on the product's weight.

*Setup Guide*

**Make sure you use the correct posture when lifting the product.**

Lifting using the wrong posture could cause an injury.

**When lifting the product, make sure you lift at the locations indicated in the manual.**

If you lift holding other parts, the printer may fall, catching your fingers and causing an injury. See the following for details on lifting the product.

*Setup Guide*

**When placing the product on a stand with casters (wheels), make sure you secure the casters before you perform the work so that they do not move.**

If the stand moves while you are performing the work, it could cause an injury.

---

## Notes on Handling

**Warning****Do not use the printer in locations with volatile substances such as alcohol or thinner, or near naked flames.**

An electric shock or fire could occur.

**Do not use the printer if it is giving off smoke or if you notice any abnormal odors or noises.**

An electric shock or fire could occur. If any abnormalities occur, turn off the power and unplug the power cable immediately, and then contact your dealer or Epson Support.

**Never try to repair the printer yourself as this is extremely dangerous.****Do not use the printer in an environment where flammable gas or explosive gas may exist. Do not use sprays that contain flammable gas inside or near the product.**

A fire could occur.

**Only route the cables as indicated in the manual.**

A fire could occur. This could also cause damage to connected devices.

**Do not insert or drop any metallic or flammable items into the openings on the printer.**

An electric shock or fire could occur.

**Do not touch any areas inside the printer except for those indicated in the manual.**

An electric shock or burn could occur.

**Do not disassemble anything except when indicated to do so in the manual.****If the LCD for the control panel is damaged, be careful of any leaking liquid crystal.**

Provide first aid under any of the following conditions.

- If liquid adheres to your skin, immediately wipe it off and then wash the area using large volumes of soapy water.
- If any liquid gets in your eyes, flush them with clean water for at least 15 minutes, and consult a physician immediately.
- If liquid is swallowed, rinse your mouth out with water, swallow large quantities of water and vomit it back up, and consult a physician immediately.

**If any foreign objects or liquid such as water enters the printer, stop using it immediately.**

An electric shock or fire could occur. Turn off the power and unplug the power cable immediately, and then contact your dealer or Epson Support.

## Introduction

 <b>Caution</b>
<p><b>Do not sit on the product or place any heavy objects on the product.</b> Pay particular attention in houses with children. The printer could tip over or break and cause an injury.</p>
<p><b>Do not put your fingers near the paper roller section when the printer is on or when it is printing.</b> If your fingers are caught in the paper roller, an injury could occur. Only handle the paper after it has been ejected completely.</p>
<p><b>When transporting or storing the product, be sure that it is level: do not tilt it at an angle or place it upside down.</b> Ink could leak.</p>
<p><b>Do not forcefully remove the paper if it is jammed. Additionally, do not work in an unstable position.</b> The force of suddenly removing the paper could cause injury.</p>
<p><b>Do not store the cutter within the reach of children.</b> The cutter's blade could cause an injury. Pay careful attention when replacing the cutter.</p>
<p><b>Be careful not to trap your hands or fingers when opening or closing the roll paper cover.</b> Failure to observe this precaution could result in injury.</p>
<p><b>When connecting cables or optional accessories, make sure they are installed in the correct direction and that you follow the procedures exactly.</b> A fire or an injury could occur. Install the printer correctly by following the instructions in the manual.</p>
<p><b>When moving the product, make sure it is turned off, the power cable is unplugged from the outlet, and all connecting cables have been removed.</b> If cables are damaged, an electric shock or fire could occur.</p>

## Notes on the Power Supply

 <b>Warning</b>
<p><b>Make sure the blades on the plug are inserted completely into the power outlet.</b> An electric shock or fire could occur.</p>
<p><b>Unplug the plug regularly and clean between the blades and around the base of the blades.</b> If the plug is plugged in for an extended period of time, dust collects around the base of the blades and a short circuit or fire could occur.</p>
<p><b>When unplugging the plug, grip the plug itself; do not pull the power cable.</b> If the cable is damaged or the plug is deformed, an electric shock or fire could occur.</p>
<p><b>Do not insert or unplug the plug with wet hands.</b> An electric shock could occur.</p>
<p><b>Use only the type of power source indicated on the printer's label.</b> An electric shock or fire could occur.</p>
<p><b>Do not use the plug if any foreign objects such as dust have adhered to the plug.</b> An electric shock or fire could occur.</p>
<p><b>Do not use any other power cables except for the cable supplied with the printer. Also, do not use the power cable supplied with the printer for any other devices.</b> An electric shock or fire could occur.</p>



## Introduction



### Warning

**Do not use the power cable if it is damaged.**

An electric shock or fire could occur. If the power cable is damaged, contact Epson Support. Note the following points to avoid damaging the power cable.

- Do not modify the power cable.
- Do not place anything heavy on the power cable.
- Do not bend, twist, or pull forcefully on the power cable.
- Do not route the power cable near heaters.

**Do not connect too many cables to the power outlet for the power cable.**

The temperature could rise and cause a fire. Connect the power cable directly to an outlet for domestic use.



### Caution

**If you are not going to use the printer for an extended period, unplug the printer for safety reasons.**

## Notes on Consumables (Ink, Media, and so on)



### Caution

**If ink contacts your skin or enters your eyes or mouth, immediately take the following actions.**

- If ink adheres to your skin, immediately wash it off using soap and water.
- If ink enters your eyes, rinse immediately with water. Failure to observe this precaution could result in bloodshot eyes or mild inflammation. If problems persist, consult a physician immediately.
- If ink enters your mouth, consult a physician immediately.

**Do not store ink cartridges within the reach of children.**

**Do not shake the ink cartridges too hard.**

Ink may leak from the cartridge if you shake it too hard.

**Do not disassemble ink cartridges.**

If it is disassembled, ink could get in your eyes or adhere to your skin.

**Do not rub the edges of the printing paper with your hand.**





The edges of the paper are thin and sharp and could cause an injury.

## Other Notes

- Be sure your power cable meets relevant safety standards of the area where you plan to use it.
- Connect all equipment to properly grounded power outlets.
- Do not put your hand inside this product or touch the ink cartridges during printing.
- Do not put your hand inside this product or touch the printer head during printing.
- Do not put your hand inside this product or touch the white flat cable during printing.

## Notes on Manuals

### Meaning of Symbols

 <b>Warning:</b>	Warnings must be followed to avoid serious bodily injury.
 <b>Caution:</b>	Cautions must be followed to avoid bodily injury.
 <b>Important:</b>	Important must be followed to avoid damage to this product.
<b>Note:</b>	Notes contain useful or additional information on the operation of this product.
	Indicates related reference content.

### Manual Organization

The manuals for the product are organized as shown below.

You can view the PDF manuals using Adobe Reader or Preview (Mac OS X).

Setup Guide (booklet)	Provides information on how to setup the printer after unpacking it from the box. Make sure you read this manual to perform operations safely.
Online Manuals	
User's Guide (this manual)	This manual explains how to use the printer.
Network Guide (PDF)	This manual provides information on using the printer over a network.

## Opening and Viewing Manuals

### Opening Manuals

- 1 See the "Setup Guide" and execute software installation from the supplied software disc or Setup Navi.  
When installation is complete, an **EPSON Manuals** icon is created on the desktop of the computer being used.
- 2 Double-click the **EPSON Manuals** icon on the desktop.
- 3 Select the manual you want to view.

### Operating System Versions

In this documentation, the following abbreviations are used.

#### Windows

In this manual, "Windows" refers to "Windows 10", "Windows 8.1", "Windows 8", "Windows 7", "Windows Vista", "Windows XP", "Windows Server 2012", "Windows Server 2008", and "Windows Server 2003".

#### Mac OS X

In this manual, "Mac OS X" refers to "OS X El Capitan", "OS X Yosemite", "OS X Mavericks", "OS X Mountain Lion", "OS X Lion", and "Mac OS X v10.6.8".

# Printer Parts

## Front

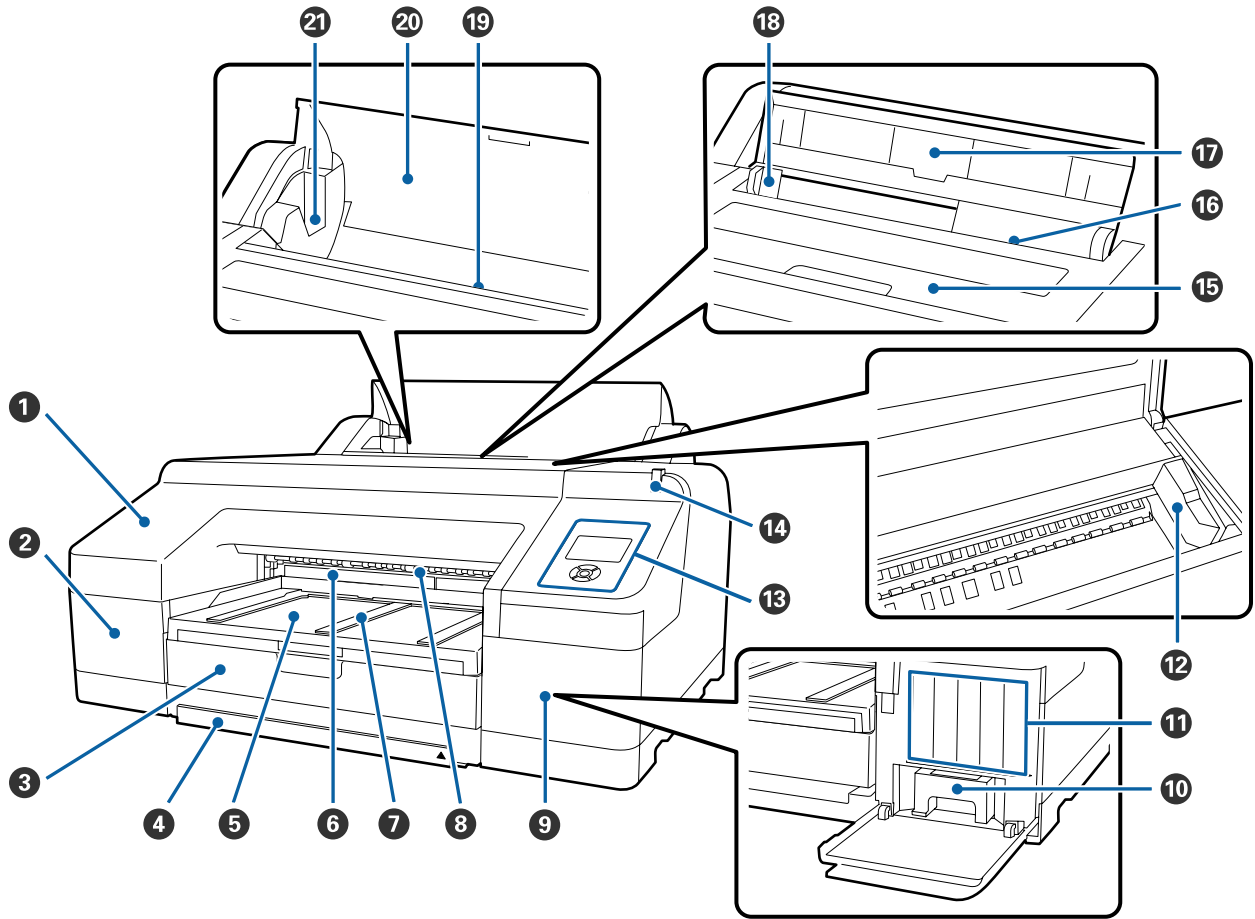

**1 Front cover**

Remove when replacing the built-in cutter or installing the optional SpectroProofer. Normally installed when using the printer.

**2 Cartridge cover (left)**

Open when replacing ink cartridges.

 [“Replacing Ink Cartridges” on page 130](#)

**3 Paper cassette**

Load cut sheets from 8 to 17 inches wide.

 [“Loading the Paper Cassette” on page 39](#)

## Introduction

### 4 Paper cassette cover

To prevent the inside of the printer from getting dusty, attach the cover to the paper cassette when printing cut sheets on super A3 or larger.

You do not need to use the cover for other cases.

 [“Loading the Paper Cassette” on page 39](#)

### 5 Output tray

Ejected paper is collected here. Extend according to the size of the paper being ejected.

### 6 Maintenance Box 2

This container collects waste ink when printing beyond the edges of the paper for borderless printing.

 [“Replacing Maintenance Box 2” on page 133](#)

### 7 Paper eject support

Supports smooth ejection of the paper by raising the paper eject support when printing on plain roll paper and when the optional SpectroProofer is installed.

 [“Loading roll paper” on page 33](#)

### 8 Front manual feeder

Feed paper into this slot when printing on cut sheets that are 0.8 mm thick or thicker.

 [“Loading and Ejecting Thick Paper” on page 46](#)

### 9 Cartridge cover (right)

Open when replacing ink cartridges or Maintenance Box 1.

 [“Replacing Ink Cartridges” on page 130](#)

 [“Replacing Maintenance Box 1” on page 132](#)

### 10 Maintenance Box 1

Container for collecting waste ink.

### 11 Ink cartridges

Install ink cartridges on the left and right for a total of 11 colors. Ink cartridge order

 [“Screen View” on page 18](#)

### 12 Print head

Fires ink via high density nozzles while moving left and right to print.

Do not move the print head by hand.

### 13 Control panel

 [“Control panel” on page 16](#)

## Introduction

### 14 Large alert lamp

Lit or flashing when an error or warning occurs in the printer.

On : An error occurred. Check the contents of the error on the control panel's screen.

Flashing : An ink or paper low warning occurred. You can specify for which consumable this warning should occur. The factory default setting is Off (do not warn).

 [“Preferences” on page 120](#)

Off : No error.

### 15 Printer cover

Open when loading thick paper, cleaning the inside of the printer, or removing jammed paper. Normally closed when using the printer.

### 16 Rear manual feeder

Manually feed paper into this slot when printing cut sheets one at a time.

 [“Loading Manually from the Rear” on page 44](#)

### 17 Paper support

Raise this support when manually feeding paper to load the paper properly. Supports paper to prevent it from falling forward or backward.

### 18 Edge guide

Move left and right depending on the size of the paper that you want to load. This prevents paper being fed at a slant.

### 19 Roll paper feeder

Paper feed slot for roll paper printing.

 [“Loading Roll Paper” on page 31](#)

### 20 Roll paper cover

To prevent the inside of the printer from getting dusty, keep this closed except when replacing roll paper.

### 21 Spindle holders

Holds the spindle loaded with roll paper. There is one on both the left and the right sides.

 [“Loading roll paper” on page 33](#)

Introduction

Rear/Spindle

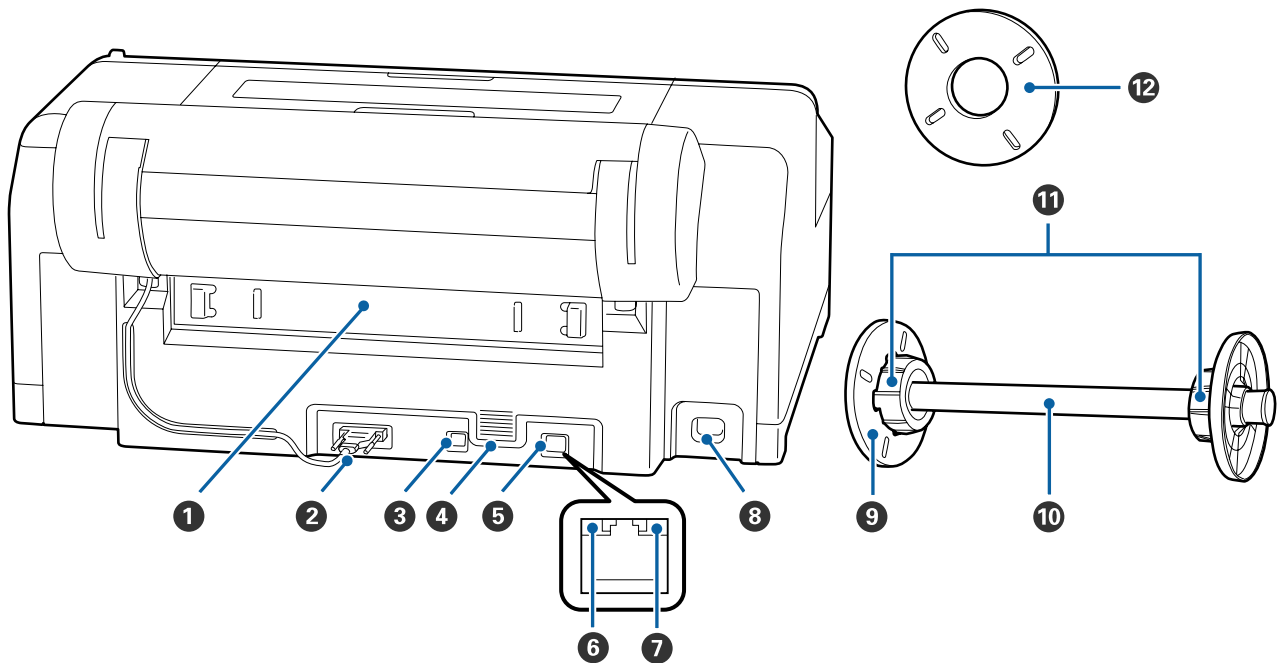

- 1 Rear unit**  
Remove if the paper jams, and then clear the jammed paper. Normally installed when using the printer.
- 2 Roll paper holder unit connector**  
Always use with the cable connected.
- 3 USB port**  
Connects the USB cable.
- 4 Airflow vents**  
Vents the air used to cool the inside of the printer.
- 5 LAN port**  
Connects the LAN cable.
- 6 Status light (green and red)**  
The color indicates the network transmission speed.  
  
 Off : 10BASE-T  
  
 Red : 100BASE-TX  
  
 Green : 1000BASE-T
- 7 Data light (orange)**  
The network connection status and data reception are indicated by a lit or flashing light.  
  
 On : Connected.  
  
 Flashing : Receiving data.

## Introduction

- ⑧ **AC inlet**  
Connects the power cable.
- ⑨ **Movable flange (black)**  
Fixes the roll paper placed on the spindle. Remove and install when loading or removing roll paper on the spindle.
- ⑩ **Spindle**  
When you want to load roll paper into the printer, place the roll paper on the spindle.
- ⑪ **Attachment**  
Install when placing roll paper with a 3-inch core on the spindle.
- ⑫ **Spacer for borderless printing**  
Install and use when you perform borderless printing on roll paper with a 2-inch core.

Paper widths that need the spacer installed for borderless printing

 [“Supported Media Sizes for Borderless Printing” on page 74](#)

Introduction

Control panel

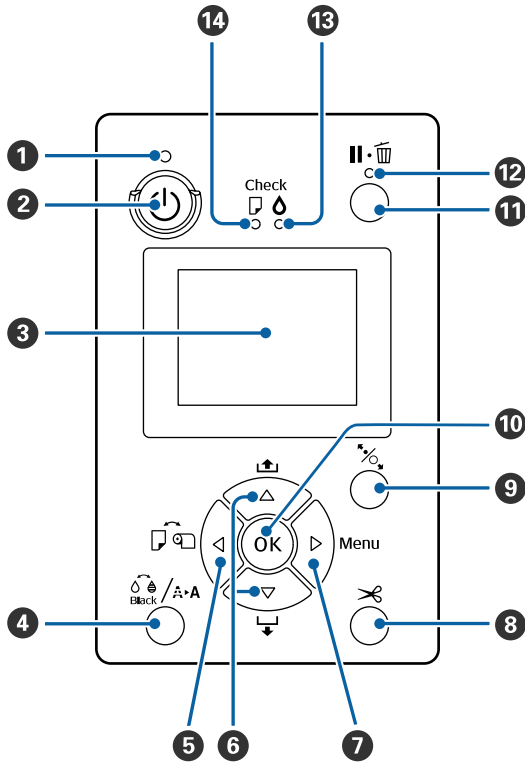

**1** **light (Power light)**  
The printer's operational status is indicated by a lit or flashing light.

On : The power is on.

Flashi ng : Receiving data or performing processes such as turning off the power, head cleaning, auto nozzle check, or changing the type of black ink.

Off : The power is off.

**2** **button (Power button)**  
Turns the power on and off.

**3** **Screen**  
Displays the printer's status, menus, error messages, and so on. ["Screen View" on page 18](#)

**4** **button (Maintenance button)**

If pressed in the ready status, the **Maintenance Menu** is displayed on the screen, and you can clean the print head, perform a nozzle check, or switch the type of black ink. If pressed while printing is temporarily stopped (paused), you can only perform a nozzle check or head cleaning. ["Maintenance menu" on page 106](#)

**5** **button (Paper Source button)**

If pressed in the ready status, or when no paper is loaded, the Paper Type Menu is displayed, and you can switch between roll paper and cut sheets, and check the paper loading method. When settings are changed, the screen icons change as shown below. You can also make the same settings from the printer driver. When printing from the printer driver, the printer driver settings are given priority regardless of the settings on the control panel.

: Prints on roll paper and cuts automatically after printing each page.

: Prints on roll paper. Does not cut after printing.

: Prints on cut sheets.

Returns to the previous screen (Parameter > Item > Menu > Ready) if pressed while the Menu is displayed on the screen.

**6** **buttons (Paper Feed buttons)**

When roll paper is loaded, you can feed (▼ button) or rewind (▲ button) the roll paper. You can feed up to a maximum of 3 m of paper by holding down the ▼ button. You can speed up the paper feed rate by holding down the button for at least two seconds. You can rewind up to 20 cm of paper by holding down the ▲ button.

If you press the ▼ button when no roll paper is loaded and **Cut Sheet** is selected from the Paper Type Menu, paper is fed from the paper cassette and ejected. ["Cleaning the paper cassette printing path" on page 138](#)

When feeding cut sheets from the rear manual feeder, press the ▼ button to feed the paper and enter ready status. ["Loading Manually from the Rear" on page 44](#)

If pressed while the Menu is displayed, you can select items and parameters. ["Menu Operations" on page 105](#)



## Introduction

**7 ▶ button (Menu button)**

- ❑ If pressed in the ready status or when no paper is loaded, the Menu is displayed. [☞ “Menu Operations” on page 105](#)
- ❑ Goes to the next screen (Menu > Item > Parameter) if pressed while the Menu is displayed.

**8 ✂ button (Paper Cut button)**

Press to cut roll paper with the built-in cutter. [☞ “Manual cut method” on page 36](#)

**9 ⌘ button (Paper Set button)**

- ❑ Locks or releases the pressure roller. [☞ “Loading and Ejecting Thick Paper” on page 46](#)  
[☞ “Loading roll paper” on page 33](#)
- ❑ When pressed after roll paper printing is complete, the pressure roller is unlocked, roll paper is automatically wound up and can be removed. When **Remaining Paper Setup** in the Menu is set to **On**, the roll paper is wound up after printing a barcode on the edge of the paper that indicates such paper information as the amount of remaining roll paper. [☞ “Printing and Reading Roll Paper Information” on page 30](#)

**10 OK button**

- ❑ If this is pressed while a parameter is selected from the Menu, the parameter is set or executed.
- ❑ If pressed while the ink is drying, the drying process is canceled.

**11 II-⏸ button (Pause/Cancel button)**

- ❑ The printer enters pause status if this is pressed while printing. To release the pause status, press the II-⏸ button again, or select **Pause Cancel** on the screen and then press the OK button. To cancel print jobs being processed, select **Job Cancel** on the screen and then press the OK button.
- ❑ If pressed while the Menu is displayed, the Menu is closed and it returns to ready status.

**12 II-⏸ light (Pause light)**

Indicates whether or not the printer is ready.

On : Cannot print. Pausing or canceling job.

Off : Ready to print.

**13 △ light (Ink Check light)**

The ink status is indicated by a lit or flashing light.

On : Indicates errors such as an installed ink cartridge is expended, an ink cartridge is not installed, or a wrong ink cartridge is installed. Check the contents of the error on the control panel's screen.

Flashi : The ink is low. We recommend replacing ng the ink cartridge as soon as possible because the ink may be expended while printing.

Off : No error.

**14 □ light (Paper Check light)**

The paper status is indicated by a lit or flashing light.

On : Indicates an error such as there is no paper or that the paper differs to the paper setting. Check the contents of the error on the control panel's screen.

Flashi : Indicates an error such as a paper jam or ng that the paper has skewed. Check the contents of the error on the control panel's screen.

Off : No error.

Introduction

Screen View

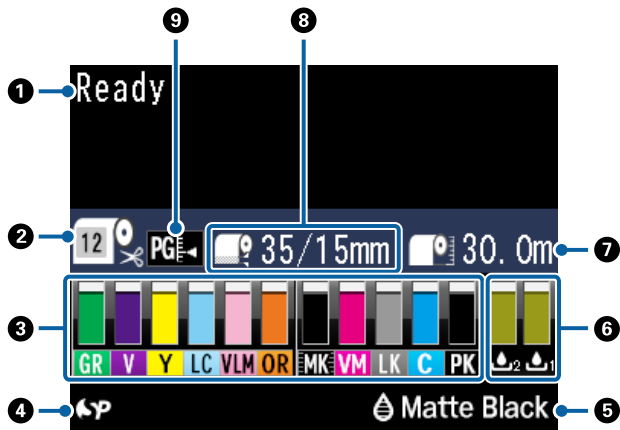

1 Messages

Displays the printer's status, operations, and error messages.

☞ "What to do When a Message is Displayed" on page 141

☞ "Using the Control Panel Menu" on page 105

2 Paper Type

The statuses of the Paper Type (roll paper or cut sheets) setting and the Auto Cut setting (roll paper) that were selected with the ◀ button are indicated by the icons in the following table.

When **Custom Paper** is selected, a number is displayed on the paper icon.

☞ "Paper" on page 113

Icon	Explanation
	Prints on roll paper. The paper is cut automatically after printing one page.
	Prints on roll paper. Auto cut is not performed.
	Prints on cut sheets.

3 Ink Cartridge Status

Displays the approximate level of remaining ink and the current status. The ink cartridge icons change as follows when the ink is low or an error occurs.

Normal                      Warning or Error

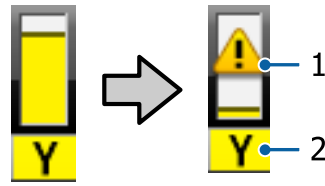

1. Status indicators

Icon	Status
	No alarm No error. The height of the indicator changes with the level of ink remaining.
	Ink is low. You need to prepare a new ink cartridge.
	An error occurred. Check the message on the screen, and clear the error.

2. Ink codes

C	Cyan
OR	Orange
Y	Yellow
LC	Light Cyan
MK	Matte Black
PK	Photo Black
VM	Vivid Magenta
LK	Light Black
GR	Green
LLK/V*	Light Light Black/Violet
VLM	Vivid Light Magenta

\* The display differs depending on the ink sets being used.

4 SpectroProofer Usage Status

The following icons indicate the installation status of the optional SpectroProofer.



SpectroProofer Mounter 17"

Icon	Status
	Available
No icon	Not installed, or it is not installed correctly.

Introduction



**5 Usage status of black ink**  
 Displays the selected black ink.

**6 Maintenance Box Status**  
 Displays the approximate amount of space in the Maintenance Box.

Icon	Status
	No error. The height of the indicator corresponds to the amount of space.
	The Maintenance Box is nearing the end of its service life. You need to prepare a new Maintenance Box.
	Maintenance Box is at the end of its service life. Replace the Maintenance Box with a new one.

**7 Remaining Paper**  
 The following icons indicate the remaining amount of loaded paper.

One of the following icons is displayed depending on whether roll paper or cut sheet is set as the paper source.





Icon	Explanation
	The amount of remaining roll paper (length) is indicated after the icon. This is displayed only when <b>Paper - Roll Paper Remaining - Remaining Paper Setup</b> is set to <b>On</b> .  <a href="#">"Printing and Reading Roll Paper Information" on page 30</a>
	The amount of remaining paper (number of sheets) in the paper cassette is indicated after the icon. This is displayed only when <b>Preferences - Cut Sheet Remaining</b> is set to <b>On</b> and <b>Cut Sheet Remaining</b> is set in the <b>Paper Menu</b> .  <a href="#">"Preferences" on page 120</a> <a href="#">"Paper" on page 113</a>

**8 Roll Paper Margin**  
 Displays the value set for **Roll Paper Margin**.

- Auto: **Standard** is set
- 15 mm: **Top 15mm/Bottom 15mm** is set
- 35/15mm: **Top 35mm/Bottom 15mm** is set
- 3mm: **3mm** is set

- 15mm: **15mm** is set
- ["Paper" on page 113](#)

**9 Platen Gap Settings**  
 Displays the **Platen Gap** settings.  
["Printer Setup" on page 117](#)

Icon	Explanation
	<b>Standard</b> is selected
	<b>Narrow</b> is selected
	<b>Wide</b> is selected
	<b>Wider</b> is selected
	<b>Widest</b> is selected

## Introduction

# Features

The main features of this printer are described below.

---

## Realizing High Resolution

Epson UltraChrome HDX ink technology provides high resolution printing to meet professional needs for photo, fine art and proofing.

## Pigmented inks with superior resistance

Pigment inks maintain more beautiful and more vibrant prints over a long period of time with their high light fastness. They are also extremely fade-resistant and can be safely displayed in direct sunlight. Additionally, the high water and ozone resistance is not only ideal for photo printing, but also allows for store displays and banners, outdoor displays of posters and so on. When you are printing for outdoor use, use lamination processing.

## Two types of black ink with maximum black density (Dmax)

By automatically switching to suit the paper type being used, the two types of black ink provided are Photo Black which realizes a smooth, professional finish on glossy paper, and Matte Black which increases black optical density using matte paper. The maximum density (Dmax) improves on previous black inks and brings out delicate tone differences in gradations.

 [“Changing the Type of Black Ink” on page 53](#)

## Chooses between two types of 10 color inks to suit your use

The following shows the two types of ink sets available for Epson UltraChrome HDX. The ink set cannot be changed once it has begun to be used.

- ❑ Light Light Black ink set ideal for gradations  
Three types of black ink density, Photo Black, Light Black and Light Light Black, allows you to

bring out delicate tone differences in black-and-white images.

In addition, the other seven colors, including Orange and Green, realize superior color reproduction creating bright and vivid images in green to yellow and yellow to red.

- ❑ Violet ink set providing a wide range of color reproduction  
As well as Orange and Green, this set comes with eight color inks including the newly developed Violet. By realizing superior color reproduction creating bright and vivid images in green to yellow and yellow to red, as well as deep shades of blue, we have achieved the industry's best PANTONE cover ratio.

---

## Realizing High Productivity

### Excellent color stability leads to efficient printing

The color stabilizes in a short time so it can safely be used for pre-press workflow and color editing, achieving high work efficiency.

### Realizing high productivity through continuous printing

Our paper cassettes, which can be used even for glossy paper, can hold up to 250 sheets of plain paper (for paper 0.1 mm thick) or up to 100 sheets of Epson proofing paper.

Also, up to 50 sheets of printed paper can be held in the output tray (up to the number of sheets in the paper cassette when there are less than 50 sheets loaded in the paper cassette). This helps to reduce the burden of handling output paper or replenishing cut sheets.

 [“Loading the Paper Cassette” on page 39](#)

### Paper cutting speed

With the addition of a high speed rotary cutter you can cut paper faster than ever.

 [“Cutting the roll paper” on page 36](#)

## Introduction

### Automatic color management (SpectroProofer mouter)

With the optional SpectroProofer Mounter 17" installed, you can print, dry, and do color measurement work in sequence on roll paper. Another optional colorimeter ILS30EP can be used for a variety of color measurement conditions including the new M1 standard. (Supports M0/M1/M2)

Also, with the addition of a function to prevent misaligned measurement positions, this model provides more accurate readings than conventional models.

To use this you need commercially available RIP software.

---

## Superior Ease of Use

### Automatically switch roll paper and cut sheets for printing

You can load roll paper in the printer and load cut sheets in the paper cassette at the same time. The required paper is automatically fed if you specify the paper source when printing.

 [“Loading roll paper” on page 33](#)

### Auto nozzle check prevents printing mistakes

Missing dots are detected on all nozzles extremely quickly and head cleaning is performed automatically if any missing dots are detected. This prevents printing mistakes and reduces unnecessary costs and wasted time.

 [“Print Head Maintenance” on page 122](#)

### Checking current operating status even from a distance, thanks to a large alert lamp

When an error occurs, or when ink or paper is running low, you can easily check the status of the printer even from afar, thanks to a highly visible, large alert lamp.

This helps prevent any wasted time when printing has stopped due to running out of ink or paper.

### Simplified setting operations when changing roll paper

When changing between many different types of roll paper for your printing, you can automatically make settings by using the barcode printing function, as the printer reads the recorded information such as the paper type, the amount of remaining roll paper, and low paper warning values.

 [“Printing and Reading Roll Paper Information” on page 30](#)

### Improved color adjustment function (Epson Color Calibration Utility)

The Epson Color Calibration Utility software provided on the software disc supplied allows you to easily perform color calibration using the printer's built-in sensors.

#### Adjust all prints with one calibration

By saving the calibration data to the printer, you do not need to perform calibration for every paper type or mode. Also, you do not need to make individual calibrations when sharing the printer with multiple users.

#### Perform color management for multiple printers

You can perform color management for multiple printers that use the same ink set.

See the Epson Color Calibration Utility manual for details.

### Improved energy efficiency with sleep mode and Power Off Timer

When no print jobs are being handled, or when no operation has been performed for some time, the printer enters sleep mode to reduce power consumption. Furthermore, if the Power Off Timer function is enabled, the printer can automatically switch off to avoid wasting electricity. This function works if no print jobs are received and no operations are carried out on the control panel while the printer is not in an error status for a specified duration of time.

 [“Power Saving Settings” on page 55](#)

# Notes on Usage and Storage

## Installation space

Make sure that you secure the following space, clear of any other objects, so that paper ejection and consumable replacement are not obstructed.

See the "Specifications Table" for the external dimensions of the printer.

 ["Specifications Table" on page 179](#)

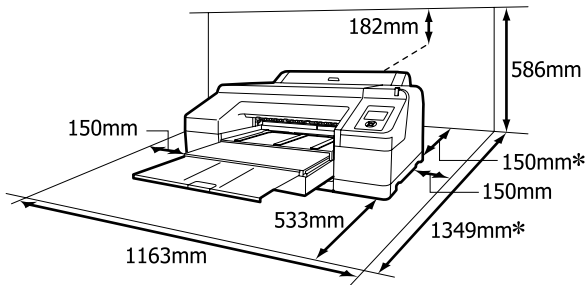

\* The following space is necessary at the rear of the printer when printing on thick paper and when printing from a paper cassette with the optional SpectroProofer installed.

Paper Size	Rear Space
A2	Approx. 370 mm
Super A3	Approx. 260 mm
A3	Approx. 200 mm
A4	Approx. 70 mm

## Notes when using the printer

Note the following points when using this printer to avoid breakdowns, malfunctions, and print quality decline.

- When using the printer, observe the operating temperature and humidity range described in the "Specifications Table".  ["Specifications Table" on page 179](#)  
Even when the conditions above are met, you may not be able to print properly if the environmental

conditions are not suitable for the paper. Be sure to use the printer in an environment where the paper's requirements are met. For more details, see the documentation supplied with the paper. Also, when operating in dry areas, air conditioned environment, or under direct sunlight, maintain the appropriate humidity.

- Capping may not occur (the print head is not positioned on the right-hand side) if the printer is turned off during a paper jam or when an error occurs. Capping is a function for automatically covering the print head with a cap (lid) to prevent the print head from drying out. In this case, turn on the power and wait a while until capping is performed automatically.
- When the power is on, do not remove the power plug or cut the power at the breaker. The print head may not be capped properly. In this case, turn on the power and wait a while until capping is performed automatically.
- Even when the printer is not in use, some ink will be consumed by head cleaning and other maintenance operations needed to keep the print head in good condition.
- Use this printer at altitudes below 2000 m.

## Notes when not using the printer

If you are not using it, note the following points when storing the printer. If it is not stored correctly, you may not be able to print properly the next time it is used.

- If you do not print for a long time, the print head nozzles may become clogged. We recommend that you print once a week to prevent the print head from clogging.
- If the paper is left in the printer, the roller of the pressure roller may leave a mark on the surface of the paper. This can also cause wavy or curled paper resulting in paper feeding problems or the print head could be scratched. Remove any paper when storing.

## Introduction

- ❑ Store the printer after confirming that the print head has been capped (the print head is positioned at the far right). If the print head is left uncapped for a long time, the print quality may decline.

**Note:**

*If the print head is not capped, turn the printer on, and then turn it off.*

- ❑ Close the roll paper cover and printer cover before storing. If you are not using the printer for a long time, put an anti-static cloth or cover on the printer to prevent dust. The print head nozzles are very small, and they can become clogged easily if fine dust gets on the print head, and you may not be able to print properly.
- ❑ If you have not used the printer for a long time, check the print head for clogging before you start printing. Perform head cleaning if the print head is clogged.  
🔗 [“Checking for clogged nozzles” on page 123](#)

## Notes on handling ink cartridges

Note the following points when handling ink cartridges to maintain good print quality.

- ❑ The ink cartridges that are included are for the initial ink charging. The first time the printer is filled with ink after purchase, ink is consumed to make it possible to print. Prepare replacement ink cartridges and maintenance boxes in advance.
- ❑ We recommend storing ink cartridges at normal room temperature, and to use them by the expiry date printed on the cartridge packaging.
- ❑ For the best printing results, use up ink cartridges within six months after installation.
- ❑ If you move ink cartridges from a cold place to a warm place, leave them at room temperature for more than four hours before using them.
- ❑ Do not touch the IC chips on the ink cartridges. You may not be able to print properly.
- ❑ Install all ink cartridges into each slot. You cannot print if any of the slots are empty.

- ❑ Do not leave the printer without ink cartridges installed. The ink in the printer may dry, preventing it from printing as expected. Leave ink cartridges in all slots, even while you are not using the printer.
- ❑ Because the green IC chip contains the cartridge's own information, such as the remaining ink level, you can still reinstall and use the ink cartridge after removing it from the printer.
- ❑ To avoid getting dirt on the ink supply port, store the removed ink cartridge properly. The ink supply port has a valve in it so it does not need to be capped.
- ❑ Removed ink cartridges may have ink around the ink supply port, so be careful not to get any ink on the surrounding area when removing the cartridges.
- ❑ To maintain the quality of the print head, this printer stops printing before ink cartridges are completely expended.
- ❑ Although the ink cartridges may contain recycled materials, this does not affect printer function or performance.
- ❑ Do not dismantle or remodel ink cartridges. You may not be able to print properly.
- ❑ Do not drop or knock ink cartridges against hard objects; otherwise, the ink may leak.

## Notes on handling paper

Note the following points when handling and storing the paper. If the paper is not in good condition, print quality may decline.

Check the documentation supplied with each paper.

## Notes on Handling

- ❑ Use Epson special media under normal room conditions (temperature: 15 to 25°C, humidity: 40 to 60%).
- ❑ Do not fold the paper or scratch the surface of the paper.



## Introduction

- ❑ Avoid touching the printable surface of the paper with your bare hands. Moisture and oils from your hands can affect print quality.
- ❑ Handle roll paper by holding the edges. We recommend wearing cotton gloves.
- ❑ Cut sheets may be wavy or curled if the temperature and humidity change. Be careful not to scratch or soil the paper, and flatten it with your hand before loading it in the printer.
- ❑ Do not wet the paper.
- ❑ Do not throw away the paper packaging as you can use it for storing the paper.
- ❑ Avoid locations that are subject to direct sunlight, excessive heat, or humidity.
- ❑ Keep cut sheets in their original package after opening, and keep them in a flat place.
- ❑ Remove roll paper that is not in use from the printer. Rewind it correctly and then store it in the original packaging that came with the roll paper. If you leave the roll paper in the printer for a long time, its quality may decline.

### Notes on handling printed paper

To maintain long lasting, high quality print results, note the following points.

- ❑ Do not rub or scratch the printed surface. If they are rubbed or scratched, the ink may peel off.
- ❑ Do not touch the printed surface; Failure to observe this precaution may cause ink to rub off.
- ❑ Make sure the print outs are completely dry before folding or stacking; otherwise, the color may change where they touch (leaves a mark). These marks will disappear if they are separated immediately and dried; however, they will remain if not separated.
- ❑ If you put the print outs in an album before they are completely dry, they may be blurred.
- ❑ Do not use a dryer to dry the print outs.
- ❑ Avoid direct sunlight.

- ❑ Prevent color distortion while displaying or storing the print outs by following the instructions in the paper's documentation.

#### **Note:**

*Typically, print outs and photos fade over time (color distortion) due to the effects of light and various constituents in the air. This also applies to Epson special media. However, with the correct storage method, the degree of color distortion can be minimized.*

- ❑ *See the documentation supplied with Epson special media for detailed information on handling the paper after printing.*
- ❑ *The colors of photos, posters, and other printed materials appear different under different lighting conditions (light sources<sup>\*</sup>). The colors of print outs from this printer may also appear different under different light sources.*  
<sup>\*</sup> *Light sources include sunlight, fluorescent light, incandescent light, and other types.*



## Introduction

# Introducing the Software

As well as the printer driver, a variety of software packages are also provided such as Network easy configuration and plug-in software to add functionality to commercially available packages. You can install the software from the software disc supplied, or by downloading from the Epson website.

 [“Software on the Disc” on page 25](#)

 [“Software on the Website” on page 27](#)

---

## Software on the Disc

The supplied Software Disc contains the following software only for Windows.

If you are using Mac OS X, or if you do not have a disc drive, go to <http://epson.sn> and search for your printer. For details on using the software, see the PDF manuals or the on-line help for the software in question.

Software Name	Explanation
Printer Driver	The printer driver is required when using the printer. Follow the steps in the " <i>Setup Guide</i> " to install.  <a href="#">“Summary of the Printer Driver” on page 26</a>
Epson Manual	This software shows a list of manuals already installed on your computer. You can also check manuals updated by the EPSON Software Updater from here. Follow the steps in the supplied <i>Setup Guide</i> to install the manuals.
EPSON Software Updater	This software checks on the internet for update information for manuals and printer drivers and installs the updates. Follow the steps in the supplied <i>Setup Guide</i> to install.
Epson Network Utilities	When a network connection is setup using the <i>Setup Guide</i> , network related modules are installed. For details, see the <i>Network Guide</i> (PDF).
EpsonNet Config	With this software, you can configure various network settings for the printer from your computer. This is useful as it allows you to enter addresses and names using the keyboard.
EPSON LFP Remote Panel 2	Software for registering custom paper from a computer.
Epson Color Calibration Utility	Software that performs calibrations using the printer's built-in sensors.

Introduction

Summary of the Printer Driver

The main functions of the printer driver are described below.

- ❑ Converts print data received from applications into printable data and sends it to the printer.
- ❑ Settings such as document size and print quality can be adjusted from the settings dialogs.

Windows

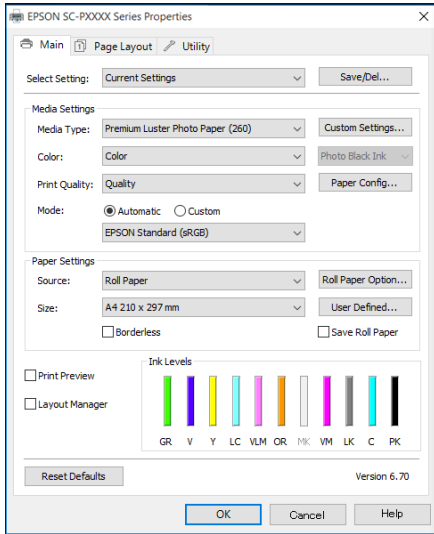

You can save these settings and easily import or export these saved settings.

👉 “Customizing the Printer Driver” on page 58

Mac OS X

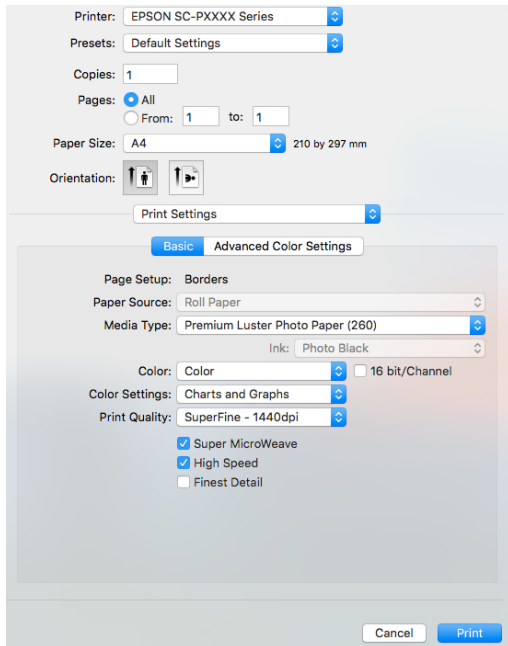

- ❑ Allows you to execute printer maintenance functions to maintain print quality, check the printer's status, and so on.

Windows

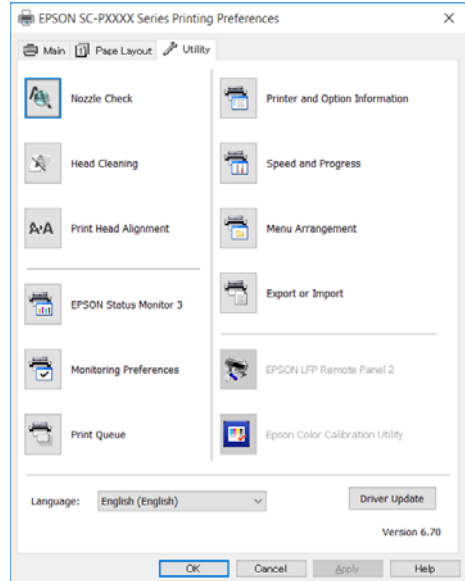

You can easily import or export printer driver settings.

👉 “Summary of the Utility Tab” on page 61

Mac OS X

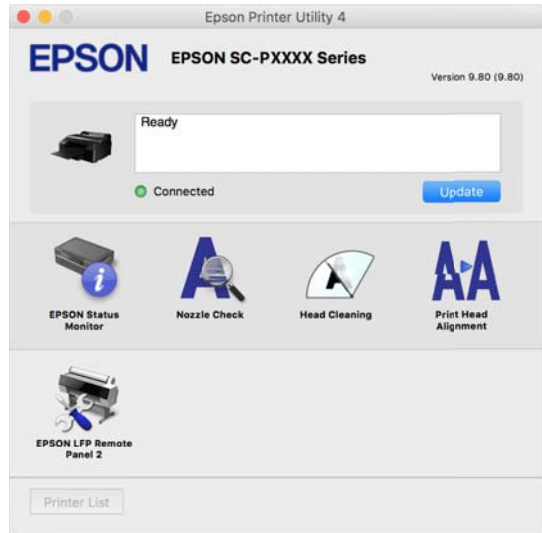

## Introduction

### Software on the Website

Aside from the software supplied on the software disc, the latest software versions for this printer can also be found on the Epson website. Download as required.

<http://www.epson.com>

**Note:**

*Depending on your country or region, you may not be able to download software from the website.*

*For more details, contact your dealer or Epson Support.*

For details on using the software, see the PDF manuals or the on-line help for the software in question.

See the following for instructions on starting and closing the software.

 [“Starting and Closing Software” on page 28](#)

Software Name	Explanation
Epson Print Layout	<p>This is a plug-in for Adobe Photoshop and Adobe Lightroom.</p> <ul style="list-style-type: none"> <li><input type="checkbox"/> By operating with Adobe Photoshop and Adobe Lightroom, you can easily perform color management.</li> <li><input type="checkbox"/> You can check the adjusted image for black-and-white photographs on the screen.</li> <li><input type="checkbox"/> You can save your preferred paper type and size and load them easily.</li> <li><input type="checkbox"/> You can easily layout and print photos.</li> </ul>
LFP Accounting Tool*	This software provides total cost calculations for printed paper, job information, and so on.
CopyFactory*	This software allows you to make enlarged copies using an Epson scanner. Check for supported scanners on the Epson website.

\* Windows only

## Starting and Closing Software

### Starting

You can start by using any of the following methods.

#### Double-click the shortcut icon on the desktop

Depending on the software being used, a shortcut icon may not be created during installation.

#### Starting from the menu

- ❑ Windows 8.1/Windows 8  
Enter the software name in the search charm, and then select the icon displayed.
- ❑ Other than Windows 8.1/Windows 8  
Click the Start button. Click the installed software name from **All Programs** (or **Programs** or **All Applications**), or from the **EPSON** folder, and then select the software you want to start.
- ❑ Mac OS X  
Click the installed software name from **Applications** or the **EPSON** folder, and then select the software you want to start.

#### Click the icon on the desktop taskbar (Windows only)

Click the icon and select the software you want to start from the menu displayed.

### Closing

The application can be closed using one of the following methods.

- ❑ Click the button (**Exit**, **Close**, , and so on).
- ❑ Select **Exit** from the toolbar menu.

## Uninstalling Software

### Windows

#### **Important:**

- ❑ *You must log in with an Administrators group.*
- ❑ *If an Administrator password or confirmation is requested, enter the password and then continue with the operation.*

**1** Turn off the printer, and unplug the interface cable.

**2** Go to the **Control Panel** and click **Uninstall a program** from the **Programs** category.

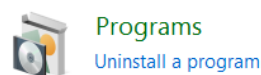

**3** Select the software you want to remove and then click **Uninstall/Change** (or **Change/Remove/Add or remove**).

You can remove EPSON Status Monitor 3 and the printer driver by selecting **EPSON SC-XXXXX Series Printer Uninstall**.

Select **EPSON LFP Remote Panel 2** to remove EPSON LFP Remote Panel 2.

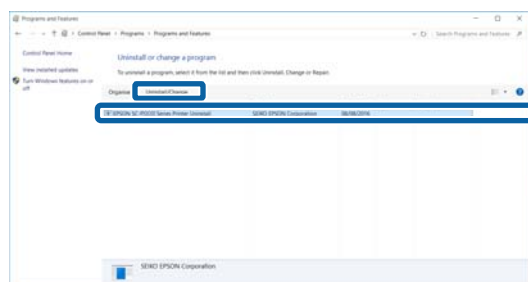

**4** Select the target printer icon, and then click **OK**.

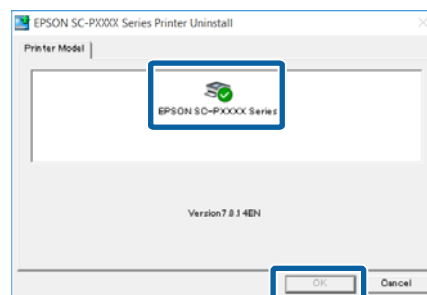

## Introduction

- 5 Follow the on-screen instructions to continue.  
When the delete confirmation message appears, click **Yes**.

Restart the computer if you are reinstalling the printer driver.

---

## Mac OS X

When reinstalling or upgrading the printer driver or other software, follow the steps below to uninstall the software in question first.

### Printer Driver

Use the "Uninstaller".

### Downloading the Uninstaller

Download the Uninstaller from the Epson website.

<http://www.epson.com/>

### Using the Uninstaller

Follow the instructions on the Epson website.

### Other software

Drag and drop folder with the software name from the **Applications** folder into **Trash** to delete.

# Basic Operations

## Loading and Removing the Roll Paper

We recommend setting **Remaining Paper Setup** before loading roll paper into the printer. See the following for more information on making settings.

Also, when loading the Epson special media UltraSmooth Fine Art Paper, you need to turn the **Auto Roll Feeding** setting to **Off** in advance. To turn the setting to **Off**, see [“Setting Auto Roll Paper Feeding” on page 31](#)

**Note:**  
The paper that can be used in the printer is detailed in the following section.  
[“Supported Media” on page 163](#)

## Printing and Reading Roll Paper Information

The printer can automatically print the following roll paper related settings in a barcode on the leading edge of the roll paper before the roll paper is removed.

- Roll Paper Remaining
- Roll Length Alert
- Paper Type

This is useful when multiple rolls are used because the barcode is read automatically and the paper settings are updated as roll paper is replaced.

To print roll paper information in a barcode and to read the printed information, set **Remaining Paper Setup** to **On** and configure the **Roll Paper Length** and the **Roll Length Alert** from the Menu.

The factory setting for **Remaining Paper Setup** is **Off**. You can change the Menu using the following procedures.

**Important:**

- Be sure to press the **⏻** button when removing the roll paper. If you do not press the **⏻** button when removing the roll paper, the barcode is not printed and you cannot manage the roll paper information.
- If **Paper Size Check** is set to **Off** from the Menu, the amount of remaining paper may not be detected correctly. When **Remaining Paper Setup** is set to **On**, do not set **Paper Size Check** to **Off**. The factory setting for **Paper Size Check** is **On**.  
[“Printer Setup Menu” on page 108](#)

Buttons that are used in the following settings

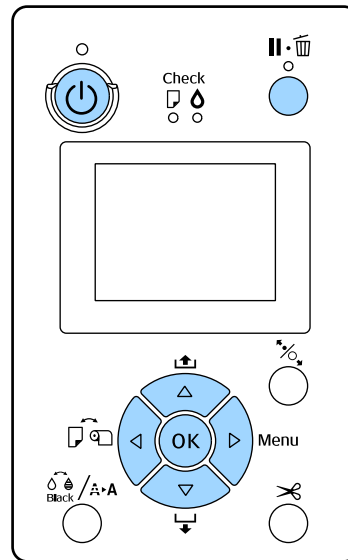

- 1** Turn on the printer by pressing the **⏻** button.
- 2** Check that paper is not loaded in the printer, and then press the **▶** button to display the Menu.
- 3** Press the **▼/▲** buttons to select **Paper**, and then press the **▶** button.
- 4** Select **Roll Paper Remaining**, and then press the **▶** button.
- 5** Select **Remaining Paper Setup**, and then press the **▶** button.
- 6** Press the **▼/▲** buttons to select **On**, and then press the **OK** button.

## Basic Operations

- 7 Press the ◀ button to return to the previous screen.
- 8 Press the ▼/▲ buttons to select **Roll Paper Length**, and then press the ▶ button.
- 9 Press the ▼/▲ buttons to set the length of the roll paper, and then press the OK button.
- 10 Press the ◀ button to return to the previous screen.
- 11 Press the ▼/▲ buttons to select **Roll Length Alert**, and then press the ▶ button.
- 12 Press the ▼/▲ buttons to set when to display the running low warning (amount of remaining roll paper), and then press the OK button.
- 13 Press the ⏏ button to close the Menu.

## Setting Auto Roll Paper Feeding

The factory setting for **Auto Roll Feeding** is **On**.

When using the Epson special media UltraSmooth Fine Art Paper, set **Auto Roll Feeding** to **Off** from the Menu before loading it in the printer. If UltraSmooth Fine Art Paper is loaded while **Auto Roll Feeding** is set to **On**, the roller of the pressure roller may leave a mark on the surface of the paper.

When using paper other than UltraSmooth Fine Art Paper, set it to **On**.

### Note:

The following differences in operation occur when turning this setting from **On** to **Off**.

- ❑ An error occurs if you try to switch to **Cut Sheet** in the Paper Type Menu while roll paper is loaded. Remove the roll paper and then change to **Cut Sheet**.
- ❑ An error occurs if you try to print by specifying the paper cassette from the printer driver while roll paper is loaded. Remove the roll paper, change to **Cut Sheet** in the Paper Type Menu, and then try again.

When using UltraSmooth Fine Art Paper, turn the setting to **Off** using the following procedure.

- 1 Make sure the printer is on.
- 2 Check that paper is not loaded in the printer, and then press the ▶ button to display the Menu.
- 3 Press the ▼/▲ buttons to select **Paper**, and then press the ▶ button.
- 4 Press the ▼/▲ buttons to select **Roll Paper Setup**, and then press the ▶ button.
- 5 Select **Auto Roll Feeding**, and then press the ▶ button.
- 6 Press the ▼/▲ buttons to select **Off**, and then press the OK button.
- 7 Press the ⏏ button to close the Menu.

## Loading Roll Paper

### Removing and mounting the attachment

Load the roll paper into the printer after placing it on the spindle supplied with the printer.

Depending on the size of the paper core, follow the steps below to mount or remove the attachment from the spindle. At the time of purchase, the flanges of the spindle are installed with an attachment.

Roll core size	Attachment mounted
2 inches	Not necessary
3 inches	Necessary

### Removing the attachment

Remove the attachment from both flanges to use roll paper with a 2-inch core.

 [“Supported Media” on page 163](#)

**Basic Operations**

- 1 Remove the black flange and the attachment from the spindle.

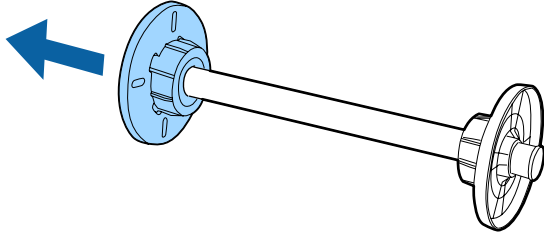

- 2 Outwardly open the two hooks clasped on the flange.

You can remove the attachment by releasing the hooks.

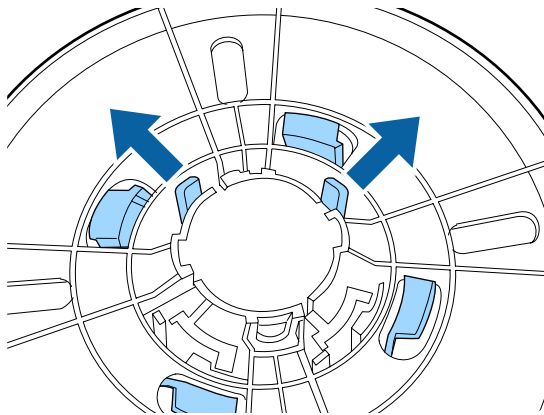

- 3 In the same way, remove the attachment on the side of the flange fixed to the spindle by outwardly opening the hooks and removing the attachment from the spindle.

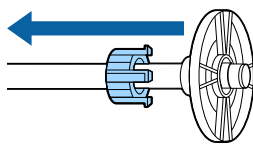

You may need the attachment for roll paper with a 3-inch core, so make sure you keep it in a safe place after removing it.

**Mounting the attachment**

Mount the attachment to both flanges to use roll paper with a 3-inch core.

[“Supported Media” on page 163](#)

- 1 Remove the black flange from the spindle.

- 2 Align the triangle marks on the flange and attachment, and then push until the hooks are fixed into place.

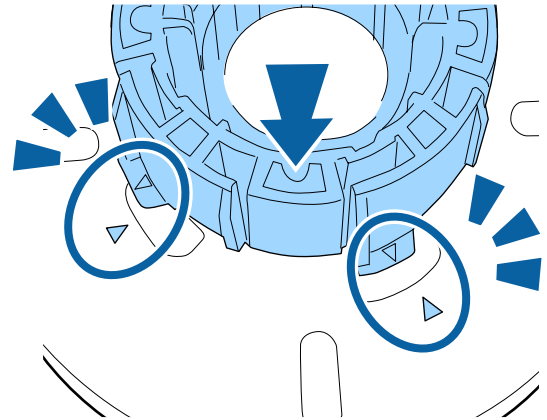

- 3 In the same way, fasten the attachment to the side of the flange fixed to the spindle by inserting the attachment into the spindle, and then fixing the attachment into place.

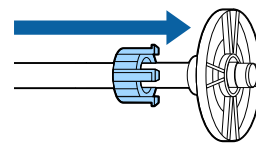

**Removing and installing the spacer**

When you perform borderless printing on roll paper, depending on the width of the roll paper, you may need to install the spacer for borderless printing supplied with the printer.

However, you cannot install the spacer for roll paper with a 3-inch core, since it is already using the attachment. Paper widths that need the spacer installed for borderless printing [“Supported Media Sizes for Borderless Printing” on page 74](#)

**Installing the spacer**

- 1 Remove the black flange from the spindle.  
When the attachment is mounted to the spindle, remove both left and right attachments.



## Basic Operations

- 2 Install the spacer into the gray flange (fixed part).  
Push the spacer until the holes in the spacer and the flange line up exactly.

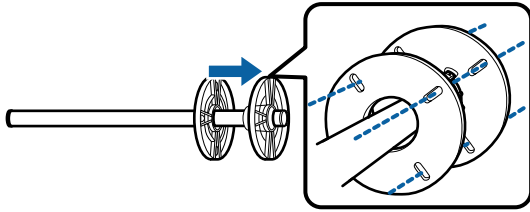

### Removing the spacer

- 1 Remove the black flange from the spindle.
- 2 Remove the spacer.  
Hold the outer edge of the spacer and pull it straight off.

### Placing roll paper on the spindle

Follow the steps below to set roll paper on the spindle supplied with the printer.

- 1 Remove the black flange from the spindle.

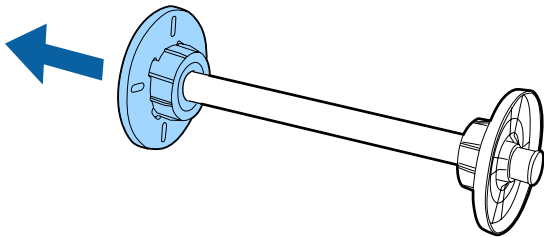

- 2 Insert the spindle into the roll paper.  
Place the roll paper on a flat surface where the end of the roll paper is hanging down towards you, and insert the spindle from the right.

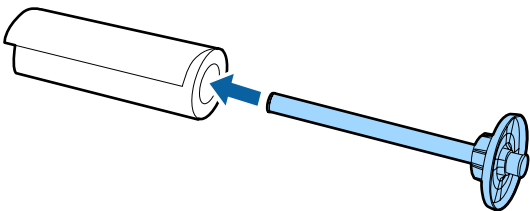

- 3 Push the roll paper so that there is no space between it and the flange fixed to the spindle.

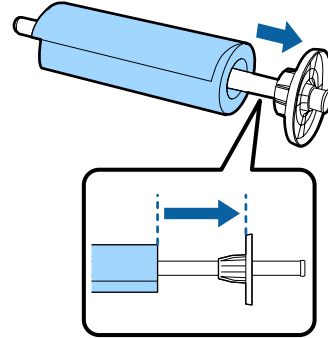

- 4 Push the black flange so that there is no space between the flange and the roll paper.

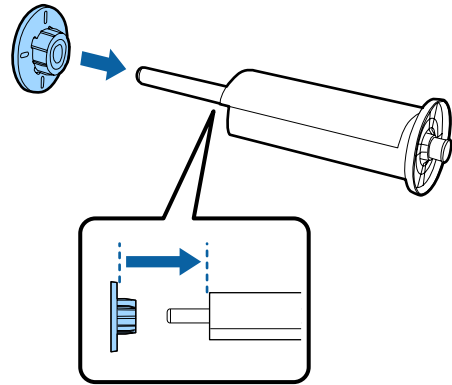

### Loading roll paper

Follow the steps below to load roll paper on the printer.

#### **!** Important:



*Insert the paper just before printing. If the paper is left in the printer, the pressure roller may leave a mark on the surface of the paper.*

- 1 Make sure the printer is on.

Basic Operations

- 2** Check the paper source settings.  
Check the paper source icon on the screen, and if it differs from the paper that you want to load, change the setting.



-  : Prints on roll paper and cuts automatically after printing each page.
-  : Prints on roll paper. Does not cut after printing.
-  : Prints on cut sheets.

To change the setting, press the ◀ button. When the Paper Type menu is displayed on the screen, select **Roll Paper/Cut** or **Roll Paper/No Cut**, and then press the OK button.

- 3** Open the roll paper cover.

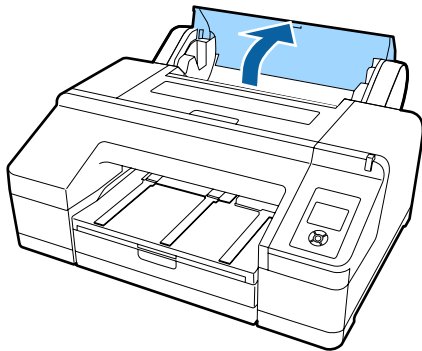

- 4** Hold with the gray flange (fixed) on the right, place both sides of the spindle into the spindle holder on the printer.  
Match the colors of the spindle holder to the colors on the end of the spindle.

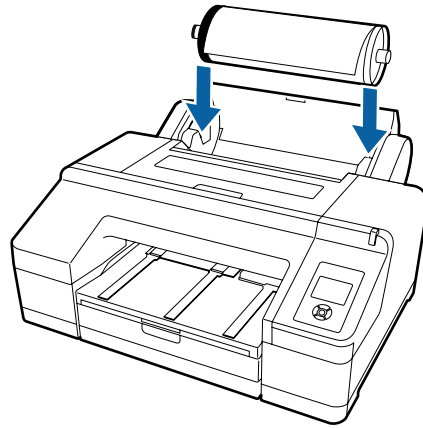

**! Important:**  
*If the spindle is set in the wrong direction, paper is not fed correctly.*

- 5** Press the  button on the control panel.  
**Insert paper until the message on the LCD panel changes** is displayed on the screen.

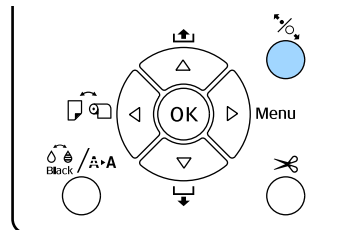

- 6** Insert the leading edge of the roll paper in the roll paper feeder.  
When inserting, make sure not to fold the edge and remove any slack.

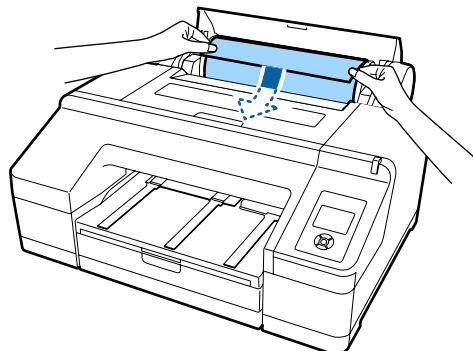

**Basic Operations**

**7** Feed the paper.

**When Auto Roll Feeding is On**

When the paper is inserted a little, the screen display changes to **Press the % button.**

Check that the screen display has changed, and then press the % button to automatically feed the paper to the start position.

**When Auto Roll Feeding is Off**

Insert the paper (so that the edge of the paper comes out of the front manual feeder) until the screen display changes.

Check that the screen display has changed, and then press the % button to automatically feed the paper to the start position.

**Note:**

When **Auto Roll Feeding** is set to **On**, and a paper cassette is specified from the printer driver, the roll paper automatically returns to its standby position and the cut sheet is fed and printed from the paper cassette, even if the roll paper was loaded on the printer.

The factory setting for **Auto Roll Feeding** is **On**.

**8** Close the roll paper cover.

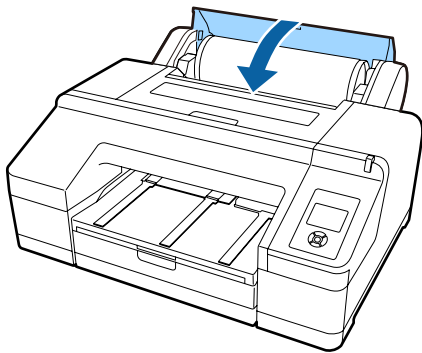

Proceed to step 9 if loading roll paper on which there is no printed bar code.

Proceed to step 10 if loading roll paper on which there is a printed bar code.

**9** Check the media type.

**Are these settings OK?** is displayed on the screen, and the media type currently specified on the printer is displayed.

When the displayed media type and the loaded media type match, press the ▼/▲ buttons to select **Yes**, and then press the OK button.

If you want to change the media type, select **No** and then press the OK button. When the Paper Type Menu is displayed, select the category according to the loaded media type, and then press the ► button. Select the media type, and then press the OK button.

**10** Slide the output tray out to the second and third extensions.

Do not raise the flap. If the flap is raised while printing, the paper may not be ejected correctly.

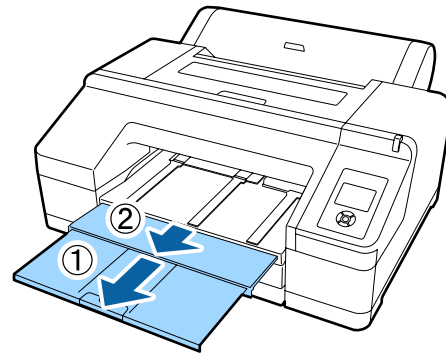

**Important:**

- ❑ The output tray can only hold one sheet of roll paper at a time. Remove each sheet of roll paper as it is ejected without letting the sheets stack up on the output tray. Also, do not allow cut sheets and roll paper to stack up together.
- ❑ Do not raise the flap when **Roll Paper/No Cut** is set from the Paper Type Menu or while performing banner printing. If the flap is raised while printing, the paper may not be ejected correctly.

**11** Raise the paper eject support depending on the paper type.

Raise the paper eject support when plain paper is loaded.

## Basic Operations

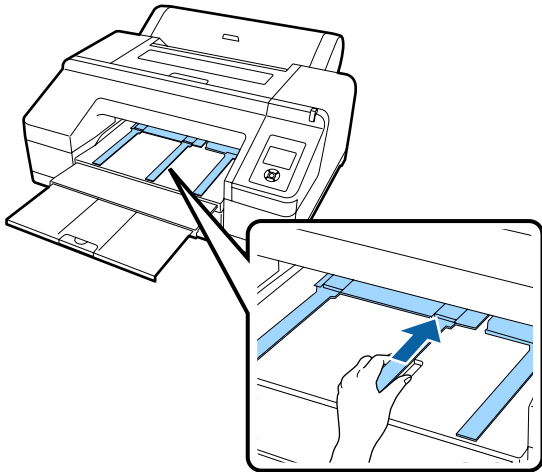

### Cutting the roll paper

After printing, you can cut the roll paper using one of the following two methods. You can specify the method either on the control panel or the printer driver. However, when printing from the printer driver, the printer driver settings are given priority regardless of the settings on the control panel.

- Auto cut:  
Cut the roll paper after printing each page automatically using the built-in cutter.
- Manual cut:  
Press the ✂ button to cut the roll paper with the built-in cutter, or use a cutter sold at a store.

**Note:**

- Some types of roll paper cannot be cut using the built-in cutter. Use a cutter sold at a store to cut the paper.
- It may take a while to cut the roll paper.

### Setting methods

#### Setting on the computer

Set **Auto Cut** from the **Main** screen - **Roll Paper Option** in the printer driver's **Properties** (or **Print Preferences**) screen.

#### Setting from the printer

Press the ◀ button on the control panel to display the Paper Type Menu, and then select it.

[“Control panel” on page 16](#)

### Manual cut method

If you set **Off** or **Roll Paper/No Cut** on the printer driver or control panel, you can cut the paper after printing using the following procedure.

- 1** While watching the inside of the printer through the window in the printer cover, press the ▼ button to feed the roll paper and adjust the cutting position to the ←✂ mark on the inside of the printer on the right-hand side.

**Note:**

The minimum length of paper you can cut with the built-in cutter is fixed to 80 or 127 mm and cannot be changed. The length is 210 mm when the optional SpectroProofer is installed. If the cutting position is shorter than the shortest length above, the paper has to be automatically fed to that length, creating a margin. Cut off the margin with a cutter sold at a store.

- 2** Press the ✂ button. When the confirmation message is displayed on the screen, use the ▼ button to select **Cut**, and then press the OK button.

The paper is cut by the built-in cutter.

**Note:**

If the roll paper cannot be cut by the built-in cutter, press the ▼ button to feed the paper to a position where you can cut it manually.

### Removing Roll Paper

Remove the roll paper from the printer after printing and store it. If the roll paper is left in the printer, the roller of the pressure roller may leave a mark on the surface of the paper.

- 1** Make sure the printer is on.

**Basic Operations**

- 2** Open the roll paper cover.

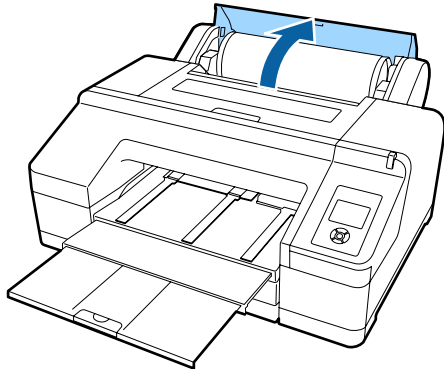

- 3** Press the **⏏** button on the control panel to release the pressure roller.

The roll paper is rewound automatically after cutting or if the printer is standing by. The printer starts to print a barcode if **Remaining Paper Setup** is set to **On** from the Menu. When barcode printing is complete, the paper rewinds.

If it does not rewind automatically, rotate the flanges in the opposite direction to rewind.

**! Important:**

*Be sure to press the **⏏** button when removing the roll paper.*

*If you do not press the **⏏** button when removing the roll paper, the barcode is not printed even if **Remaining Paper Setup** is set to **On** from the Menu, and you cannot manage the roll paper information.*

- 4** Hold both ends of the spindle and lift up from the spindle holder.

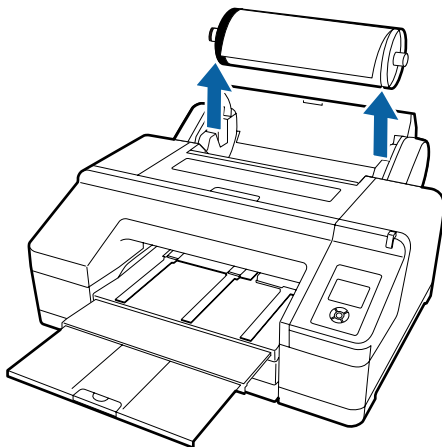

**! Important:**

*Always check that the roll paper is rewound before removing the spindle.*

*If the roll paper is not rewound, the spindle may be locked. If you try to remove the spindle when it is locked, the printer could be damaged.*

**Note:**

*When removing the roll paper, you can use the optional roll paper belt to prevent the roll paper from unwinding.*

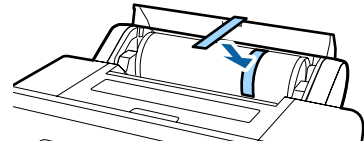

- 5** Remove the black flange from the spindle.

While holding the black flange as shown in the illustration, push the end of the spindle to pop the flange off the spindle.

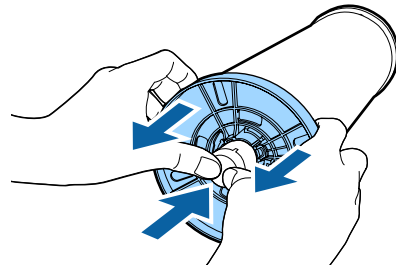

If the flange does not come off easily, lightly tap the end of the spindle on the black flange side.

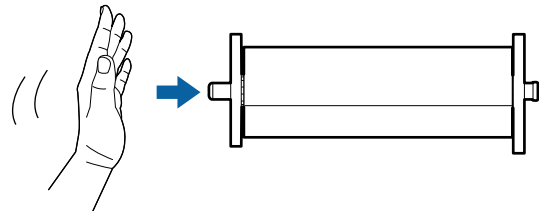

When removing a flange from the spindle while only the paper core is left on it, hold the core and push the spindle.

Basic Operations

**!** *Important:*

*When removing the roll paper, do not knock the right side of the spindle (the gray flange side) hard against the floor.*

*The right side of the spindle may be damaged by the impact.*

**6** Remove the roll paper from the spindle.

After rewinding the roll paper carefully, store it in the original package.

If you are not loading another roll paper, attach the black flange to the spindle, load it in the printer, and then close the roll paper cover.

## Loading Cut Sheets

You can load cut sheets using the following three methods.

**!** *Important:*

*If the paper is wavy or curled, flatten the paper before loading it in the printer, or use new paper. If wavy or curled paper is loaded, this printer may not be able to recognize the paper size, feed the paper, or print correctly.*

*We recommend that you return the paper to its original package and store it flat, and take it out of the package just before you use it.*

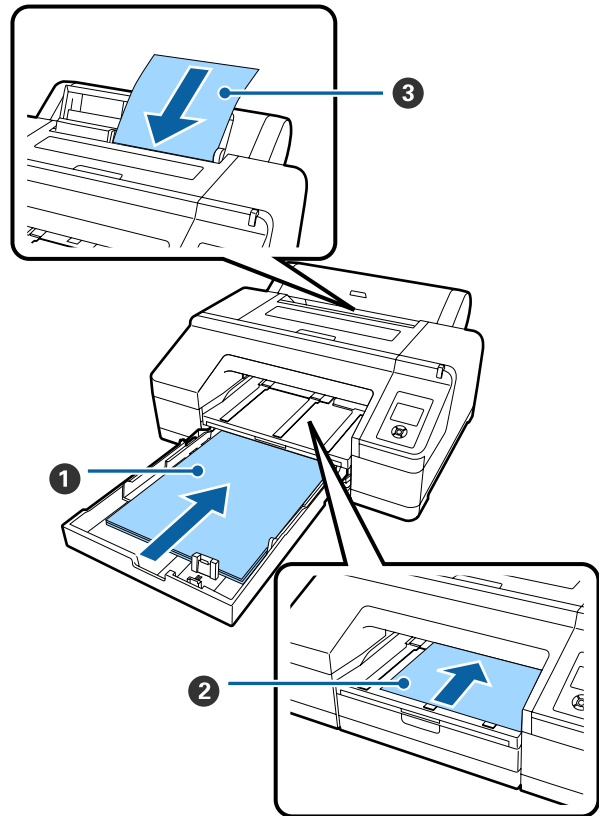

**1 Paper cassette**

You can load a stack of paper if you normally print on the same paper, or you are printing multiple pages of the same paper. You can load paper with the following specifications.

Size : 8 x 10 inch to A2

Width : 203 to 432 mm (8 to 17 inch)

## Basic Operations

Length : 254 to 594 mm (10 to 23.4 inch)

Thickne: 0.08 to 0.27 mm  
ss

How to load  "Loading the Paper Cassette" on page 39

### 2 Front manual feed (loading thick paper)

You can load thick paper with the following specifications from the front feeder. However, you cannot feed from the front feeder when the optional SpectroProofer is installed.

Size : 8 x 10 inch to A2

Width : 203 to 432 mm (8 to 17 inch)

Length : 254 to 610 mm (10 to 24 inch)

Thickne: 0.8 to 1.50 mm  
ss

How to load  "Loading and Ejecting Thick Paper" on page 46

### 3 Rear manual feed

You can load cut sheets with the following specifications manually one by one. Use this feeding method to print one sheet of a media type or paper size that is different from the ones loaded in the paper cassette, or when measuring colors on color charts that have already been printed with the Epson Color Calibration Utility.

Size : 8 x 10 inch to A2

Width : 203 to 432 mm (8 to 17 inch)

Length : 254 to 610 mm (10 to 24 inch)

Thickne: 0.08 to 0.79 mm  
ss

How to load  "Loading Manually from the Rear" on page 44

### Space at the rear

When loading thick paper or printing from the paper cassette with the optional SpectroProofer installed, paper is ejected once from the rear of the printer before printing. Therefore, make sure the following space is secured. If the printer is set up near a wall, make sure there is enough space at the rear.

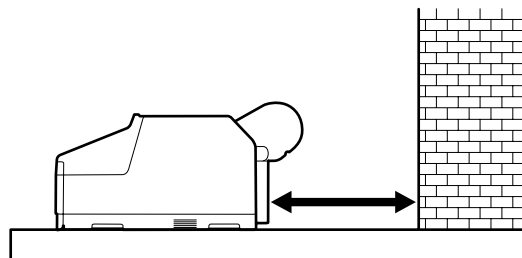

Paper Size	Rear Space
A2	Approx. 370 mm
Super A3	Approx. 260 mm
A3	Approx. 200 mm
A4	Approx. 70 mm

## Loading the Paper Cassette

### Important:

- Do not remove or insert the paper cassette while printing. It may cause print quality to decline or cause a paper jam. If you remove the paper cassette while printing, wait until printing is complete to reinsert it.
- When loading paper in the paper cassette, always remove the paper cassette from the printer and follow the steps below. If paper is loaded while the paper cassette is still in the printer, it could cause print quality to decline or cause a paper jam.

### Note:

Some paper types cannot be printed from the paper cassette.  "Epson Special Media Table" on page 163  
Use the front manual feed or rear manual feed method for these papers.



### Basic Operations

Unless otherwise noted, these illustrations show when loading paper that is super A3 or larger.

- 1 Remove the output tray.  
Lift the edge of the output tray slightly to remove it.

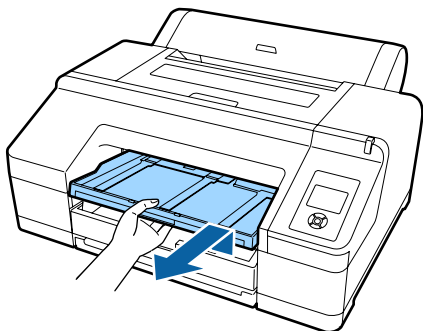

- 2 Slide out the paper cassette, and then hold both sides of the cassette to pull it out.

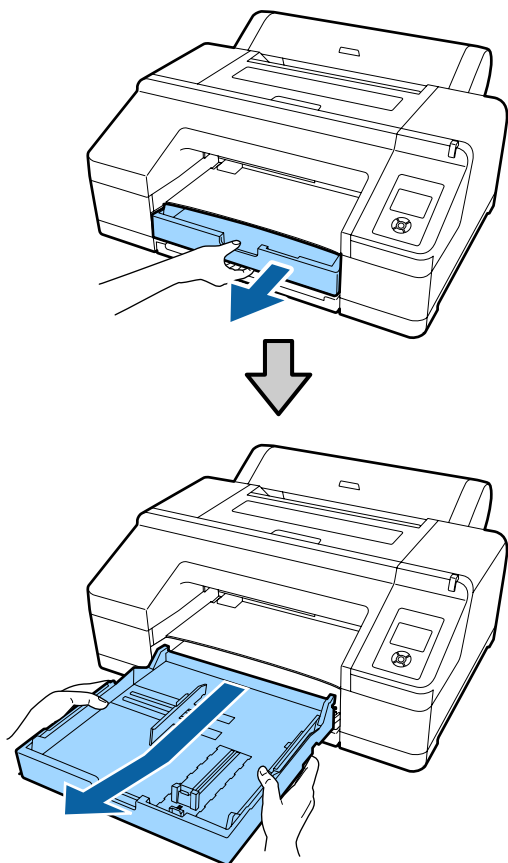

Proceed to step 6 if loading paper that is A3 or smaller.

- 3 Remove the paper cassette cover if loading paper that is super A3 or larger.  
Use a soft cloth to wipe away any dust on the paper cassette cover.

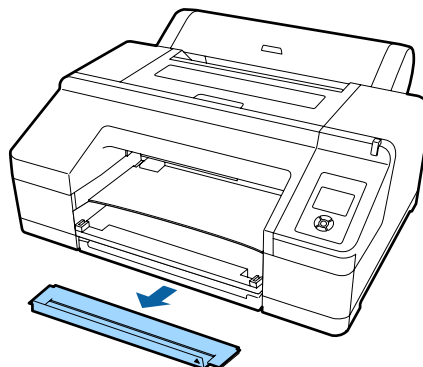

- 4 Extend the paper cassette as far as possible.

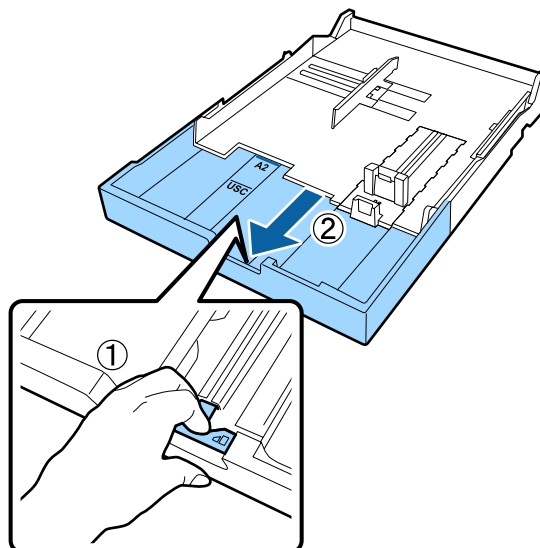

When extending the paper cassette, pull the lever in the paper cassette while extending. It locks in place when the lever is released.

Extend the paper cassette as far as possible.



Basic Operations

- 5** Expand the slider.  
Make sure you move the slider to the edge of the paper cassette.

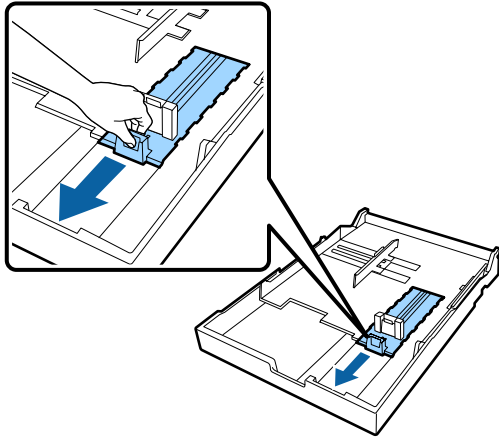

- 6** Expand the edge guide.

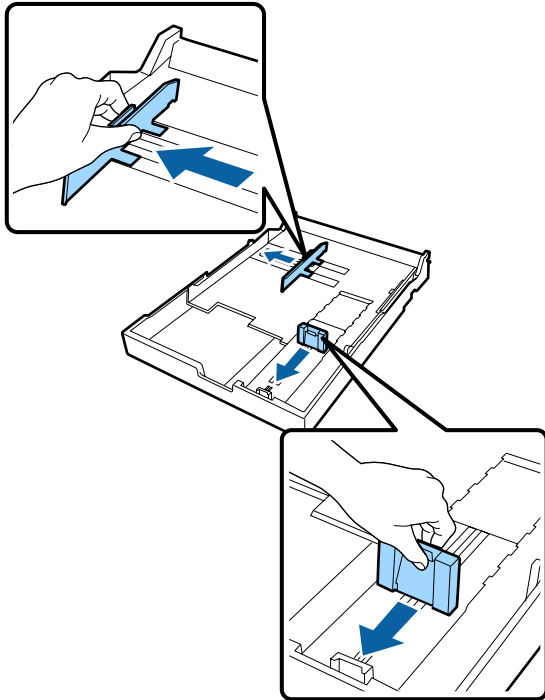

- 7** Fan the paper you want to load three times on each side before loading.

When loading paper into the paper cassette, be sure to fan paper for the front and rear three times on each side.

Number of sheets that can be loaded at one time "Cut sheet" on page 168

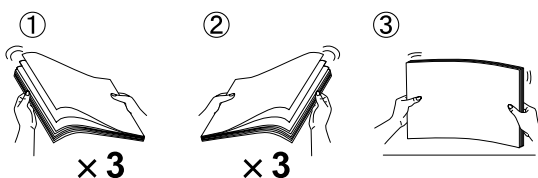

- 8** Load paper in the paper cassette with the printable side face down.

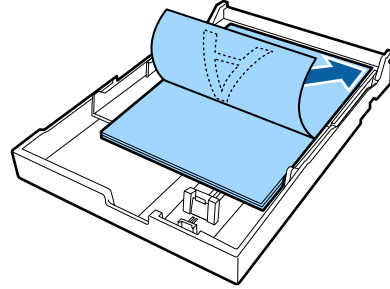

**Note:**

- You can load up to 250 sheets (thickness 0.1 mm) of plain paper in the paper cassette. If paper is loaded above the edge guide mark (▼), paper cannot be fed correctly. The maximum number of sheets you can load in the paper cassette differs depending on the paper type. See the following for more information on the maximum number of sheets for Epson special media. "Cut sheet" on page 168
- We recommend refilling the paper cassette once paper has completely run out, rather than adding on top of paper already in the cassette.

- 9** Fit the edge guide to the edge of the paper.  
Move the edge guide without moving the slider.

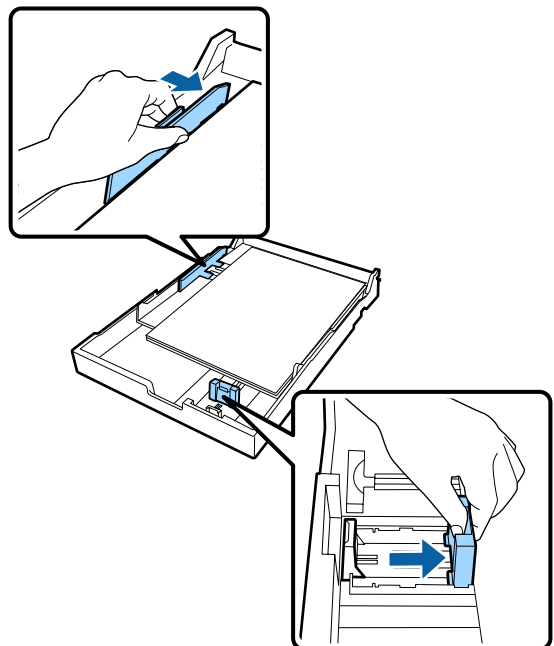

## Basic Operations

- 10** Insert the paper cassette.  
Push it firmly into the printer.

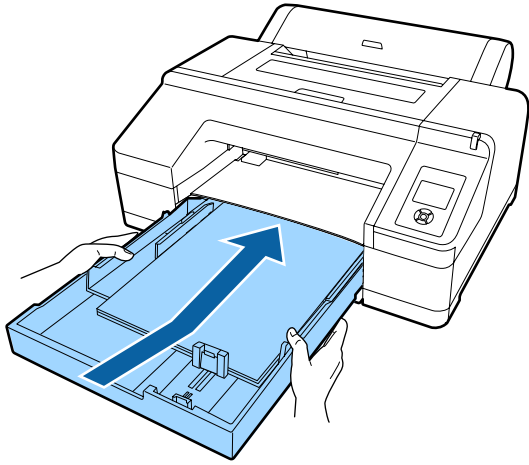

- 11** Install the paper cassette cover removed in step 3 when loading paper that is super A3 or larger.

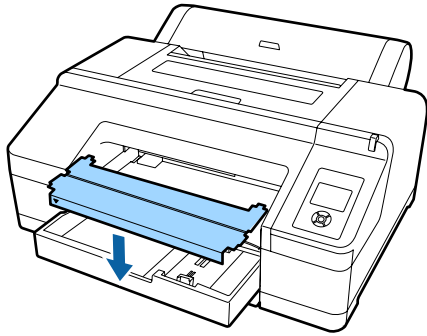

**Note:**  
*Fold up the paper cassette cover and store it at the bottom front of the printer when loading paper that is A3 or smaller.*

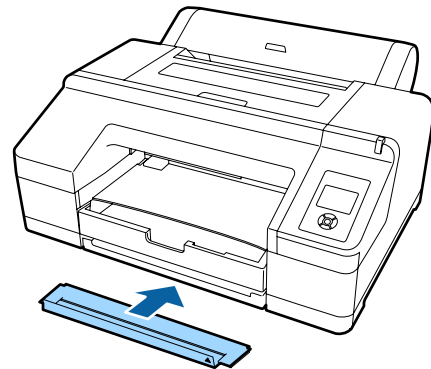
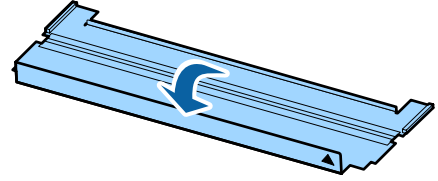

- 12** Replace the output tray.

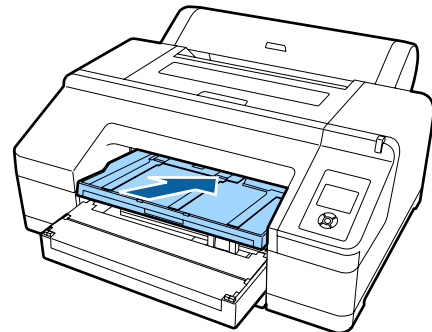

- 13** Extend output tray to suit the paper size and raise the flap.  
Adjust the output tray as follows depending on the size of the paper loaded in the paper cassette.

**Basic Operations**

**For A4**

Slide out the third extension of the output tray, raise the flap, and then push the extension back in.

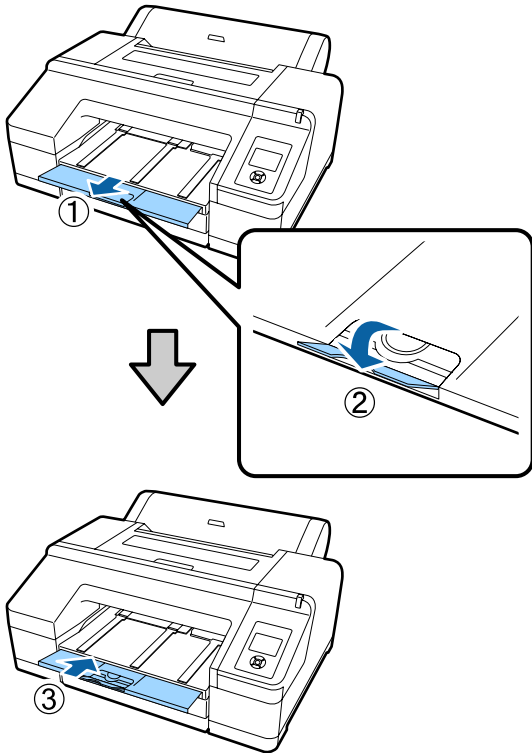

**For A3**

Pull out the third extension of the output tray, and then raise the flap.

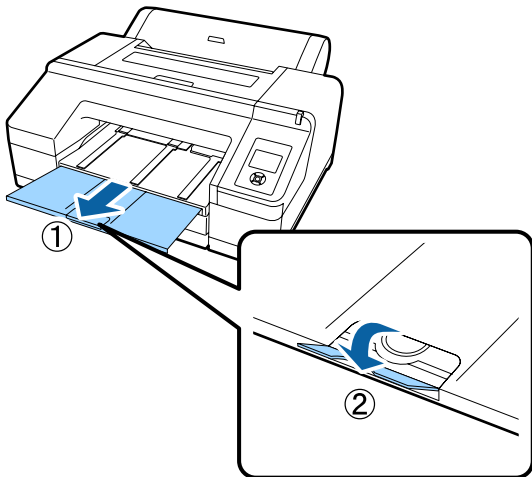

**For super A3 or larger**

Slide out the second and third extensions of the output tray, and then raise the flap. Make sure that you align the marks on the second extension of the output tray and the paper cassette.

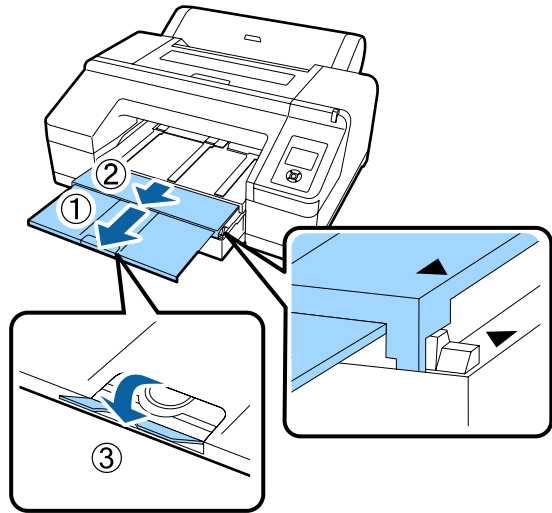

**! Important:**

The output tray can hold up to 50 ejected cut sheets. However, when the number of sheets that can be loaded in the paper cassette is less than 50, the maximum number the output tray can hold is the same as the number of sheets in the paper cassette. Do not allow more than 50 cut sheets to stack up on the output tray. Also, do not mix roll paper and cut sheets on the output tray.

When the optional SpectroProofer is installed, remove each sheet as it is printed, regardless of the size. If multiple sheets stack up on the output tray, color measurement accuracy may decline.

**Note:**

Confirm that the paper eject support is lowered, unless the optional SpectroProofer is installed. If the paper eject support is raised, lower it before printing.

**14** Make sure the printer is on.

Basic Operations

- 15 Check the paper source settings.  
Check the paper source icon on the screen, and if it differs from the paper that you want to load, change the setting.

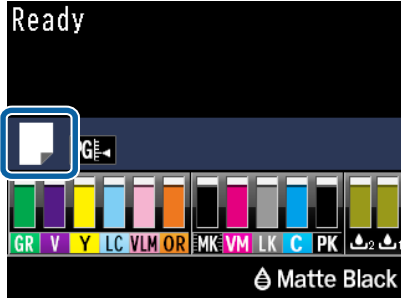

- : Prints on roll paper and cuts automatically after printing each page.
- : Prints on roll paper. Does not cut after printing.
- : Prints on cut sheets.

To change the setting, press the ◀ button. When the Paper Type Menu is displayed on the screen, select **Cut Sheet** and then press the OK button.

**Note:**  
When **Auto Roll Feeding** is set to **On** in the Menu, and a paper cassette is specified from the printer driver, the roll paper automatically returns to its standby position and the cut sheet is fed and printed from the paper cassette even if roll paper was loaded on the printer.  
However, if roll paper is specified from the printer driver in a subsequent job, the roll paper is automatically fed and printed.  
The factory setting for **Auto Roll Feeding** is **On**.

**Loading Manually from the Rear**

- 1 Make sure the printer is on.

- 2 Check the paper source settings.  
Check the paper source icon on the screen, and if it differs from the paper that you want to load, change the setting.

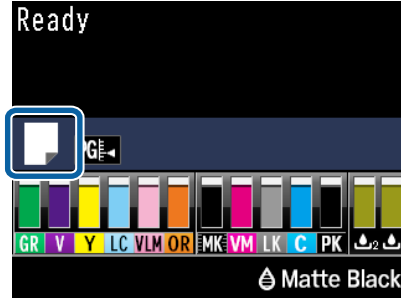

- : Prints on roll paper and cuts automatically after printing each page.
- : Prints on roll paper. Does not cut after printing.
- : Prints on cut sheets.

To change the setting, press the ◀ button. When the Paper Type Menu is displayed on the screen, select **Cut Sheet** and then press the OK button.

- 3 Raise the paper support.  
Extend the paper support when loading A3 or larger paper.

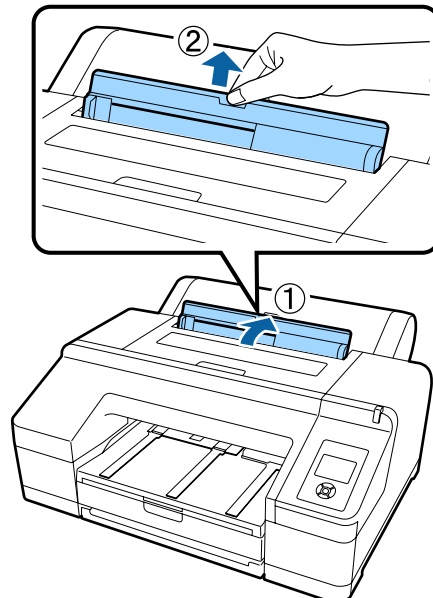

### Basic Operations

- 4** Set the edge guide according to the width of the paper you want to load.

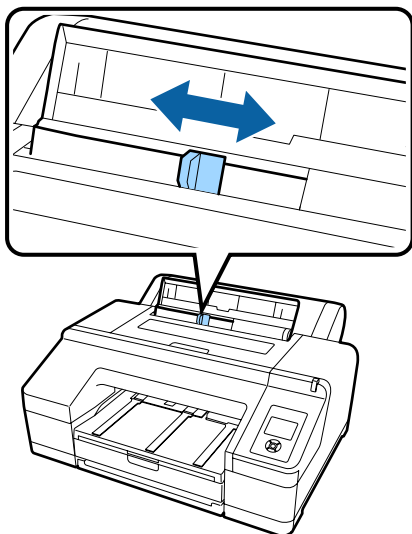

- 5** Insert the paper into the rear manual feeder with the printable side face up as shown in the illustration.

Insert the paper until it reaches the bottom.

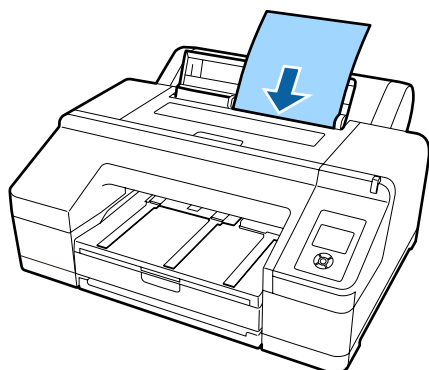

**Note:**

For Epson Color Calibration Utility color charts, insert the page from the top with the printed side facing up.

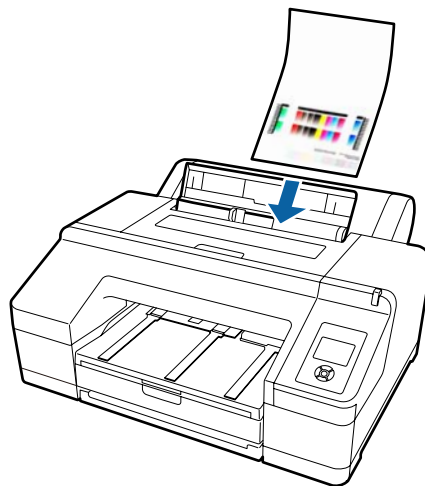

- 6** Check that the edge of the paper is inserted all the way to the part that has gray rollers. Press the ▼ button to feed the paper.

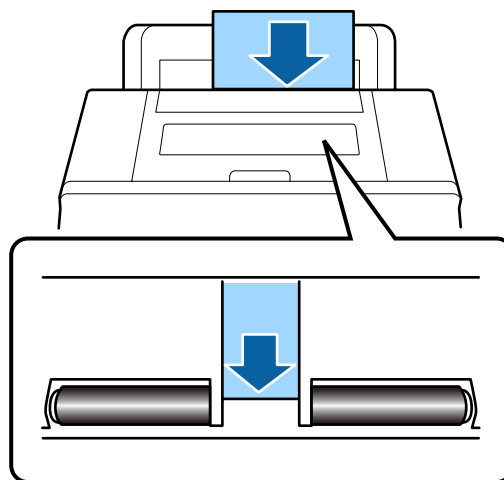

- 7** Slide the output tray out to the second and third extensions.

Do not raise the flap. If the flap is raised while printing, the paper may not be ejected correctly.

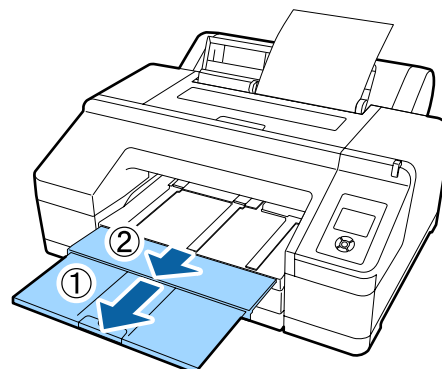

## Basic Operations

**Important:**

Remove each sheet of paper as it is ejected without letting the sheets stack up on the output tray.

**Note:**

Confirm that the paper eject support is lowered, unless the optional SpectroProofer is installed. If the paper eject support is raised, lower it before printing.

## Loading and Ejecting Thick Paper

**Important:**

When the optional SpectroProofer is installed, you cannot print from the front manual feeder. Remove it by doing the opposite of the installation procedure.

*SpectroProofer Mounter 17" Setup Guide (booklet)*

### How to load

- 1 Make sure the printer is on.
- 2 Check the paper source settings. Check the paper source icon on the screen, and if it differs from the paper that you want to load, change the setting.



 : Prints on roll paper and cuts automatically after printing each page.

 : Prints on roll paper. Does not cut after printing.

 : Prints on cut sheets.

To change the setting, press the ◀ button. When the Paper Type Menu is displayed on the screen, select **Cut Sheet** and then press the OK button.

- 3 Press the ⌘ button to release the pressure roller. Insert paper until its edge aligns with line on output tray is displayed on the screen.
- 4 Insert the paper with the printable side face up over the black roller in the front manual feeder as shown in the illustration.

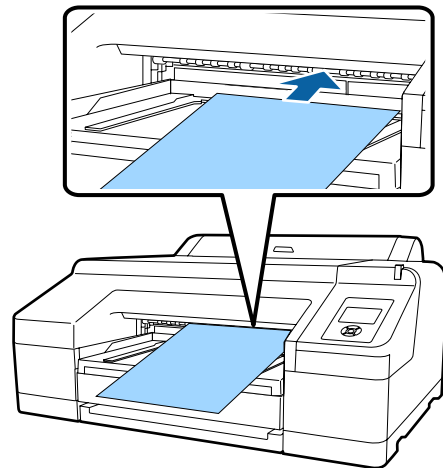

- 5 Open the printer cover.

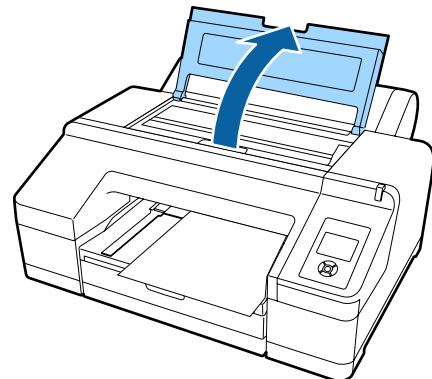

**Basic Operations**

- 6** Insert the paper under the gray roller inside the printer.  
Do not touch any of the internal printer parts as you insert the paper.

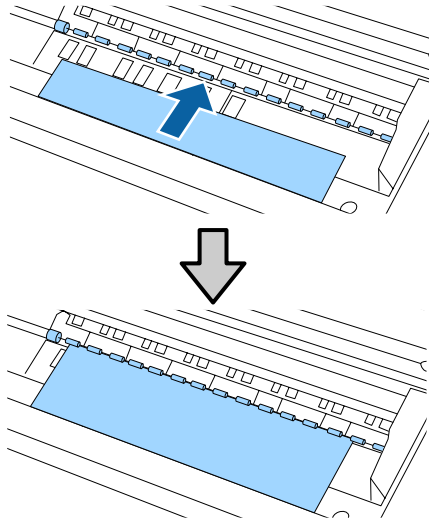

- 7** Close the printer cover.

- 8** Insert the paper and align its edge with the guide line on the output tray.

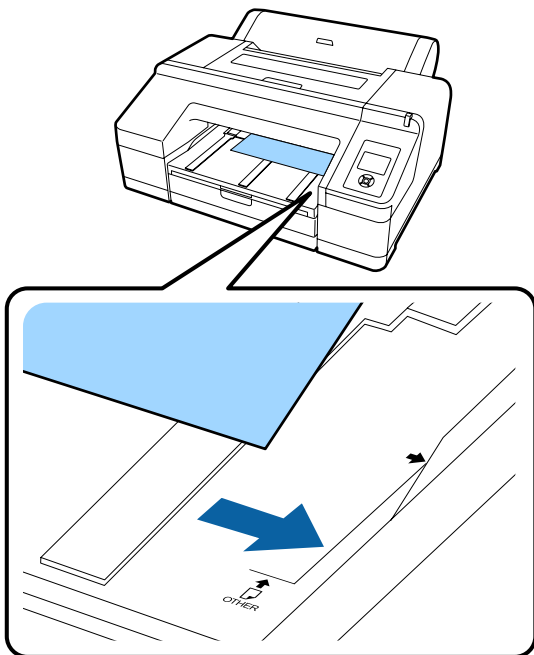

- 9** Feed the paper.  
When the paper is inserted, the screen display changes to **Press the % button**.  
Check that the screen display has changed, and then press the % button to automatically feed the paper to the start position.

- 10** Slide out the output tray to the second and third extensions.  
Do not raise the flap. If the flap is raised while printing, the paper may not be ejected correctly.

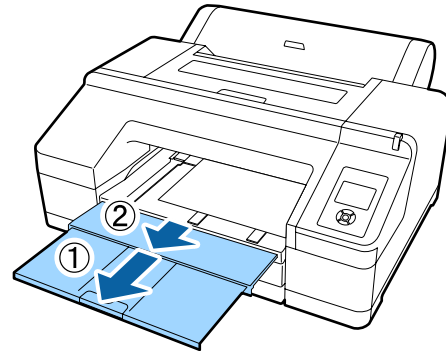

**! Important:**  
*The output tray can only hold one sheet of thick paper at a time. Remove each sheet of thick paper as it is ejected without letting the sheets stack up on the output tray.*

**Note:**  
*If the paper eject support is raised, lower it before printing.*

**How to eject paper**

Thick paper is held by the pressure roller after printing. Follow the steps below to eject paper.

- 1** Check that **Press the % button** is displayed on the screen.
- 2** Press the % button to release the pressure roller, and then pull out the paper.

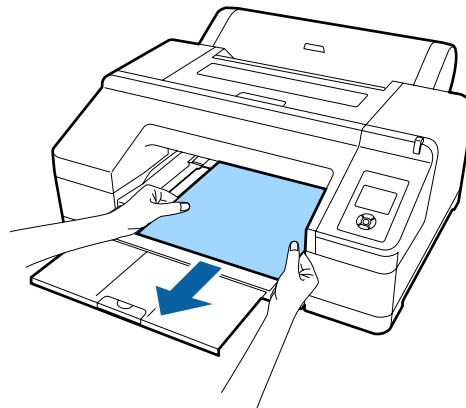

- 3** After removing the paper, press the % button.



Basic Operations

# Basic Printing Methods

This section explains how to print and how to cancel printing.

## Printing (Windows)

Make print settings such as paper size and paper source from the connected computer and then print.

- 1 Turn on the printer, and load the paper.  
 ↳ “Loading and Removing the Roll Paper” on page 30  
 ↳ “Loading Cut Sheets” on page 38

- 2 When you have created the data, click **Print** in the **File** menu.

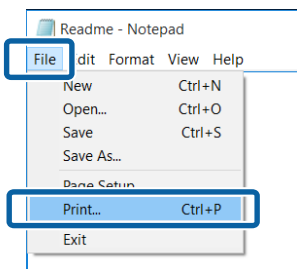

- 3 Make sure your printer is selected, and then click **Preferences** or **Properties** to display the settings screen.

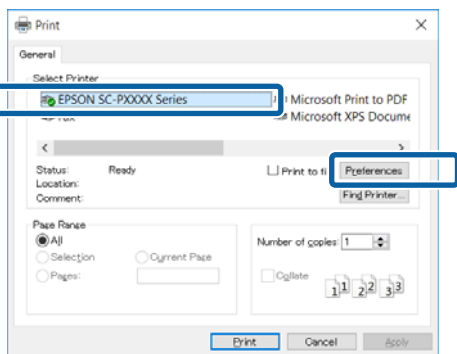

- 4 Select the **Media Type**, **Color**, **Print Quality**, **Mode**, and **Source** according to the paper loaded in the printer.

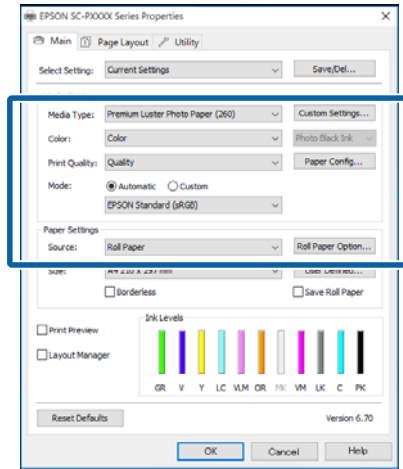

- 5 Make sure you select the same **Size** as you set in the application.

After making the settings, click **OK**.

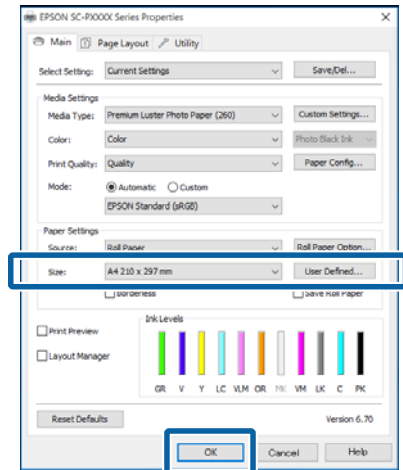

- 6 When settings are complete, click **Print**.

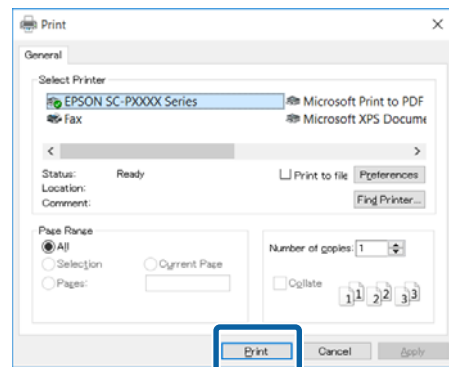

The progress bar is displayed, and printing starts.



## Basic Operations

### Screen while printing

The following screen is displayed when you start printing, and the progress bar (the computer's processing status) is displayed. On this screen you can check the remaining ink level, product numbers for the ink cartridges, and so on.

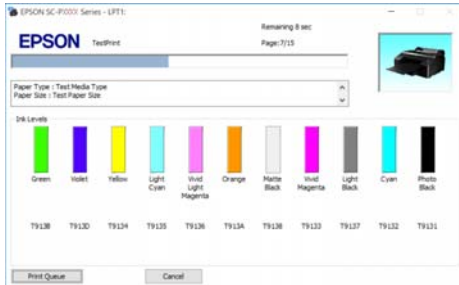

An error message is displayed if an error occurs or an ink cartridge needs replacing while printing.

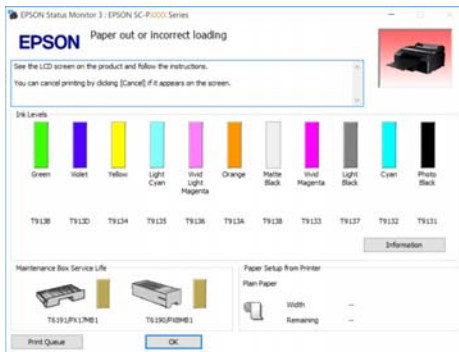

## Printing (Mac OS X)

Make print settings such as paper size and paper source from the connected computer and then print.

- 1 Turn on the printer, and load the paper.
  - 🔗 [“Loading and Removing the Roll Paper” on page 30](#)
  - 🔗 [“Loading Cut Sheets” on page 38](#)
- 2 When you have created the data, from the **File** menu of the application, click **Print** and so on.

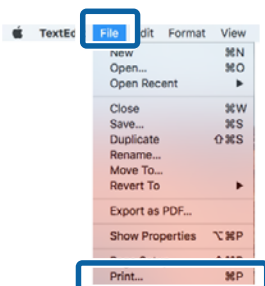

- 3 Click **Show Details** at the bottom of the screen.

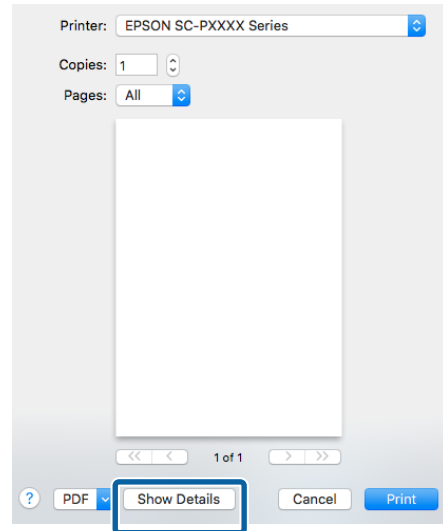

For Mac OS X v10.6.8, click the arrow (⌵) on the right of the printer name to make settings on the Page Setup screen.

**Note:**  
If page settings are not displayed in the print dialog, click the "page settings" option (e.g., **Page Setup**) in the **File** menu of the application.

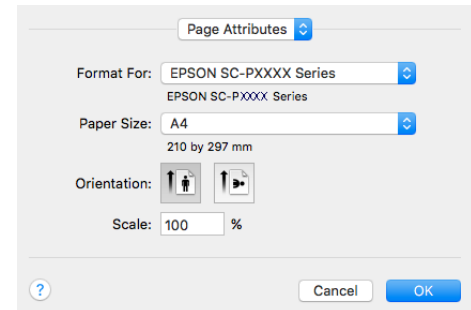

- 4 Check that this printer is selected, and then set the paper size.  
Select the paper size, borderless printing options, and paper source in the **Paper Size** menu.

## Basic Operations

Settings for the paper source must also be done in step 5, depending on the item.

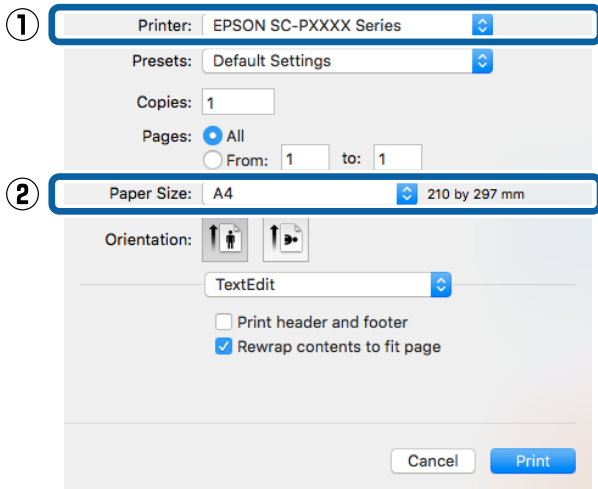

Also, if an error occurs while printing, a notification message is displayed.

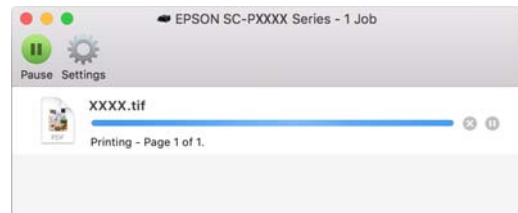

**5** Select **Print Settings** from the list, and then set each item.

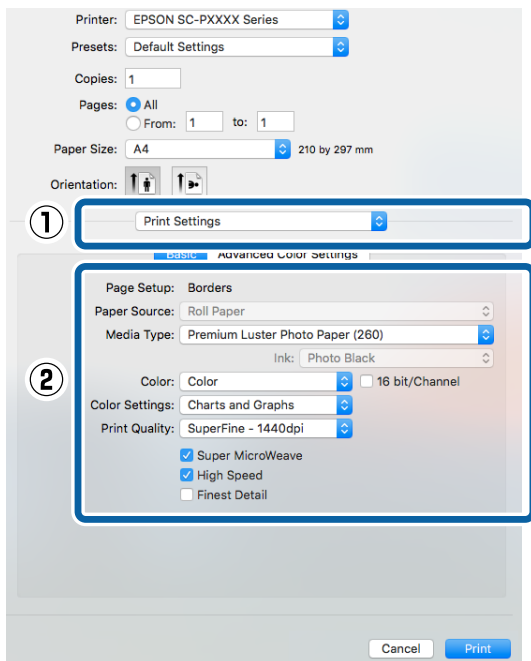

Set the **Media Type**, **Color**, **Print Quality**, and other settings according to the type of paper loaded in the printer. Normally, you can print correctly just by setting items in the **Print Settings** screen.

**6** When settings are complete, click **Print**.

The printer icon is displayed in the Dock while printing. Click the printer icon to display the status. You can check the progress of the current print job and the printer status information. You can also cancel a print job.

Basic Operations

### Canceling Printing (Windows)

When the computer has finished sending data to the printer, you cannot cancel the print job from the computer. Cancel on the printer.

🔗 “Canceling Printing (from the Printer)” on page 51

**When the progress bar is displayed**  
Click **Cancel**.

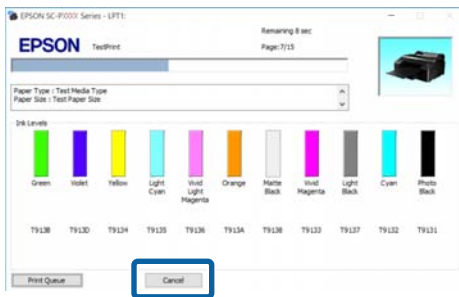

**When the progress bar is not displayed**

1 Click the printer icon on the Taskbar.



Whether or not an icon is displayed depends on the settings selected for Windows.

2 Select the job you want to cancel, and then select **Cancel** from the **Document** menu.

To cancel all jobs, click **Cancel All Documents** in the **Printer** menu.

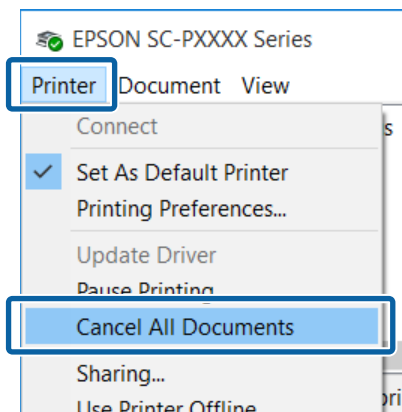

If the job has been sent to the printer, print data is not displayed on the above screen.

### Canceling Printing (Mac OS X)

When the computer has finished sending data to the printer, you cannot cancel the print job from the computer. Cancel on the printer.

🔗 “Canceling Printing (from the Printer)” on page 51

1 Click the printer icon in the Dock.



2 Select the job you want to cancel, and then click **Delete**.

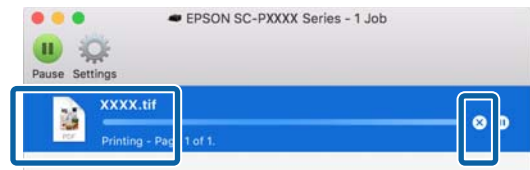

If the job has been sent to the printer, print data is not displayed on the above screen.

### Canceling Printing (from the Printer)

Press the **II** button, select **Job Cancel** on the screen, and then press the **OK** button.

The print job is canceled even in the middle of printing. It may take a while before the printer returns to ready status after canceling a job.

**Note:**

You cannot delete print jobs which are in the print queue on the computer using the above operation. See "Canceling Printing (Windows)" or "Canceling Printing (Mac OS X)" in the previous section for information on deleting print jobs from the print queue.

Basic Operations

# Printable area

This section describes the printable areas for the printer.

If the margin set in an application is larger than the following setting values, sections beyond the specified margins are not printed. For example, if 15 mm is selected for the left and right margins in the printer menus and the document fills the page, the 15 mm at the left and right sides of the page will not be printed.

## Roll Paper Printable Area

The gray area in the illustration below shows the printable area.

When printing borderless on the left and right, the left and right margins are 0 mm. When printing borderless on all edges, all margins are 0 mm.

The arrow in the illustration indicates the direction of the ejected paper.

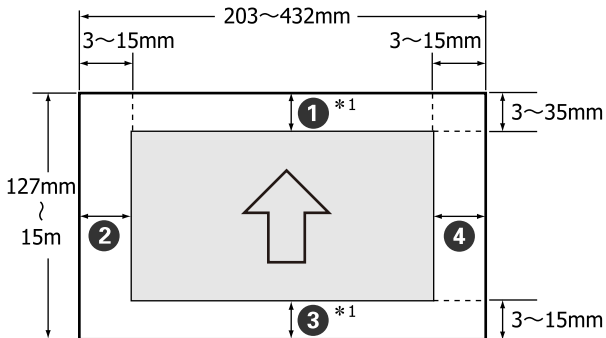

The margins for roll paper differ as shown below, depending on the Roll Paper Margin setting in the Menu.

Roll Paper Margin Settings "Printer Setup Menu" on page 108

indicates factory default settings.

Roll Paper Margin Parameter	Margin Values
Standard	①, ③ = 15 mm*2
	②, ④ = 3 mm
Top 15mm/Bottom 15mm	①, ③ = 15mm
	②, ④ = 3 mm

Roll Paper Margin Parameter	Margin Values
Top35mm/Bottom15mm	①=35 mm
	③=15mm
	②, ④=3 mm
3mm	①, ②, ③, ④=3 mm
15mm	①, ②, ③, ④=15mm

- \*1 Selecting **Roll Paper (Banner)** in the printer driver sets the top and bottom margins of the paper to 0 mm.
- \*2 When **Standard** is selected, the value for ① is 20 mm for the following paper.

Premium Glossy Photo Paper (250)/Premium Semigloss Photo Paper (250)/Premium Luster Photo Paper (260)/Premium Semimatte Photo Paper (260)

**Important:**

- Printing is distorted when the trailing edge of the roll paper comes off the core. Make sure the trailing edge does not come inside the printing area.
- The print size does not change even when the margins are changed.

## Cut Sheets Printable Area

When printing borderless on the left and right, the left and right margins are 0 mm.

The arrow in the illustration indicates the direction of the ejected paper.

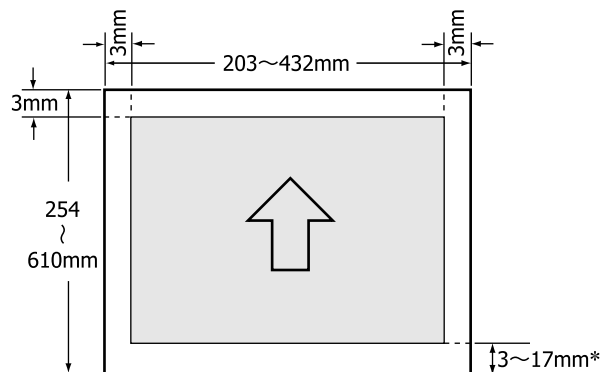

## Basic Operations

- \* When printing with margins the default value is 14 mm.

The default value for the bottom margin is 17 mm when printing borderless on the left and right.

## Changing the Type of Black Ink

This printer allows you to set both Photo Black ink and Matte Black ink and switch between them depending on the paper type.

Photo black ink reduces the grainy feeling of photo papers, giving them a smooth, professional finish. Matte black ink significantly increases black optical density when printing on matte type papers.

See the following section to select a suitable black ink for the media type.

 [“Epson Special Media Table” on page 163](#)

### **Note:**

*If there is not enough ink remaining for the switch, you will need to replace the cartridge. It may be possible to print with ink cartridges that could not be used for a black ink switch.*

---

## Switching Automatically

You can switch black inks and print from the printer driver.

Set **Auto Black Ink Change** to **Auto** from the Printer Setup menu in advance.

 [“Printer Setup” on page 117](#)

**1**

Display the printer driver's Main screen.

 [“Printing \(Windows\)” on page 48](#)

 [“Printing \(Mac OS X\)” on page 49](#)

**2**

Select the paper type from the **Media Type** menu.

Depending on the media type you select, black ink is switched automatically during printing.

Basic Operations

Windows

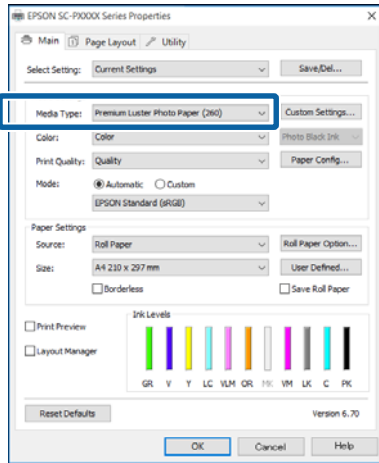

Mac OS X

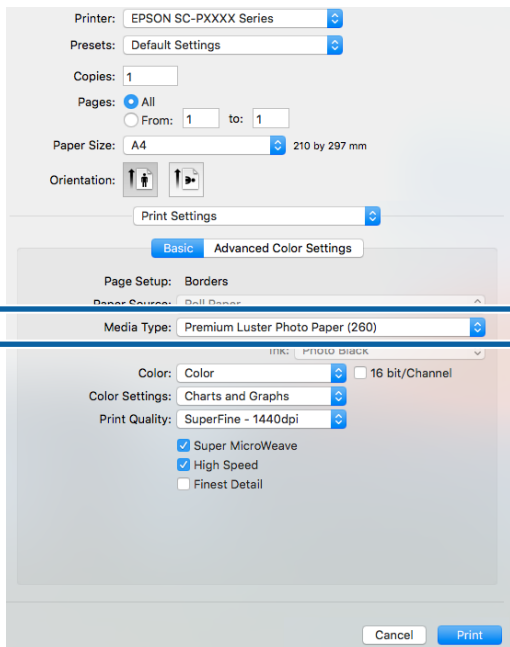

**Note:**

- ❑ The black ink type that can be used for printing varies depending on the media type.
- ❑ You can select the type of black ink from the printer driver when the media type selected supports both Photo Black and Matte Black. [☞ “Supported Media” on page 163](#)
- ❑ If the printer status cannot be acquired, the black ink type may change automatically.

**3** Check other settings, and then start printing.

Switching Manually

Change from the control panel.

Buttons that are used in the following settings

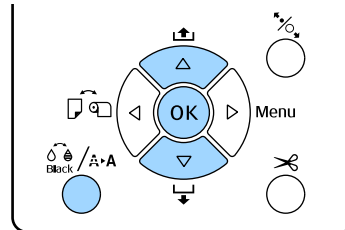

**1** Turn on the printer by pressing the ⏻ button.

**2** Press the button to display the **Maintenance Menu**.

**Note:**  
 You cannot change the types of black ink by pressing the button while printing is paused. **Change Black Ink** is not displayed on the menu.

**3** Press the / buttons to select **Change Black Ink**, and then press the OK button.

**4** The name of the black ink to be switched to is displayed based on the current settings. Press the OK button.

After switching is complete, the Menu closes. Make sure that the type of black ink has changed at the bottom right on the screen.

## Power Saving Settings

The printer offers the following two power management options.

### Sleep mode

The printer enters sleep mode when there are no errors, no print jobs being received, and no control panel or other operations performed. When the printer enters sleep mode, the control panel's screen turns off and the internal motors and other parts switch off to consume less power.

Press any button on the control panel (except for the ) to display the control panel's screen. However, under these conditions, the screen display turns off again after 30 seconds if no operations are performed.

The printer comes out of sleep mode completely and resumes its normal status only when it needs to perform hardware operations, for example, when it receives a print job, or if you press the  button after recovering the screen display.

You can select the time to enter sleep mode from **5 minutes, 15 minutes, 60 minutes, 120 minutes, and 210 minutes**. At default settings, the printer enters sleep mode if no operations are performed for 15 minutes. The delay can be changed from the Preferences menu.

 [“Preferences” on page 120](#)

#### Note:

*When the printer enters sleep mode, the control panel's screen goes blank as if the power has been turned off, but the  light remains lit.*

### Power Management

The printer is equipped with a Power Management option that automatically turns the printer off if no errors occur, no print jobs are received, and no control panel or other operations are performed for a set period of time. The delay before the printer turns off automatically can be selected from values between 1 and 24 hours in increments of 1 hour.

The default setting is 8 hours.

The printer turns off automatically if no errors occur, no print jobs are received, and no operations on the panel or other operations are performed for eight hours or longer.

Power Off Timer settings can be adjusted from the Preferences menu.

 [“Preferences” on page 120](#)

### About Power Management

You can adjust the time before Power Management is applied. Any increase will affect the printer's energy efficiency. Please consider the environment before making any change.

Using the Printer Driver(Windows)

# Using the Printer Driver (Windows)

## Displaying the Settings Screen

You can access the printer driver in the following two ways:

- From Windows applications  
📖 "Printing (Windows)" on page 48
- From the Control Panel

### From the Control Panel

Follow the steps below when specifying common settings among applications or performing printer maintenance, such as Nozzle Check or Head Cleaning.

**1** On the **Control Panel** click **Hardware and Sound** and then **View devices and printers**.

**For Windows Vista**

Click **Control Panel - Hardware and Sound**, and then **Printer**.

**For Windows XP**

Click **Control Panel - Printers and Other Hardware**, and then **Printers and Faxes**.

**Note:**

*If your Windows XP Control Panel is in **Classic View**, click **Control Panel**, and then **Printers and Faxes**.*

**2** Right-click your printer icon, and click **Printing preferences**.

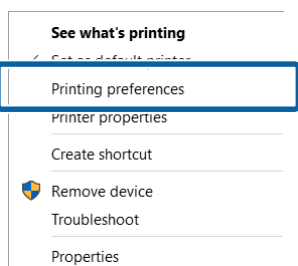

The printer driver setting screen is displayed.

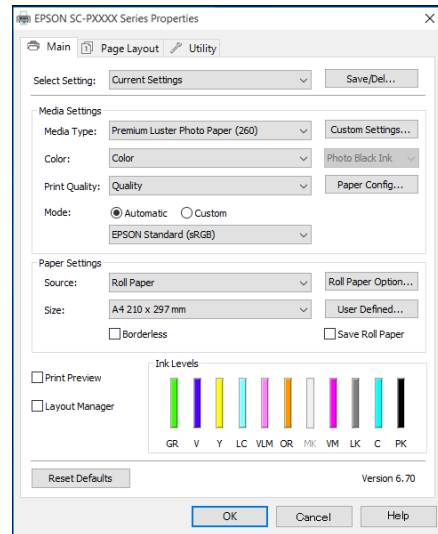

Make the necessary settings. These settings become the default settings of the printer driver.



Using the Printer Driver(Windows)

# Displaying Help

You can access the printer driver help in the following two ways:

- ❑ Click **Help**
- ❑ Right-click on the item you want to check and display

## Click the Help Button to Display

By displaying help, you can use the contents page or keyword search to read the help.

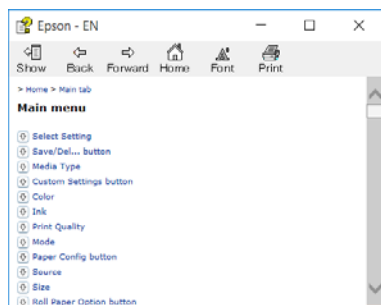
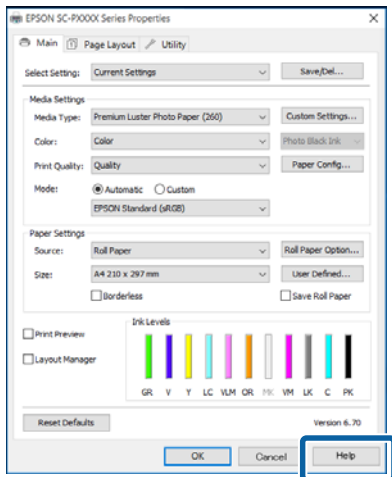

## Right-click on the item you want to check and display

Right-click the item, and then click **Help**.

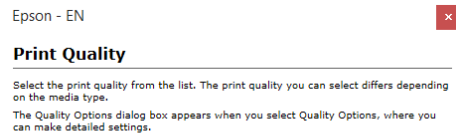
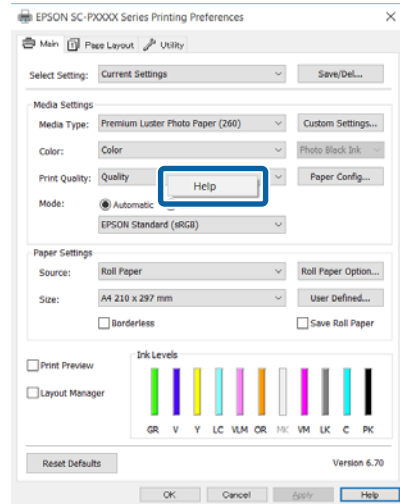

**Note:**

In Windows XP, click  on the title bar, and then click the help item you want to view.

Using the Printer Driver(Windows)

# Customizing the Printer Driver

You can save the settings or change the display items as you prefer.

## Saving various settings as your Select Settings

You can save all printer driver settings as a Select Setting. Additionally, in Select Setting the recommended settings for a variety of uses are already available.

This allows you to easily load settings that have been stored in Select Settings, and repeatedly print using exactly the same settings.

- 1 Set each item for the **Main** screen and the **Page Layout** screen that you want to save as your Select Settings.
- 2 Click **Save/Del** in the **Main** or **Page Layout** tab.

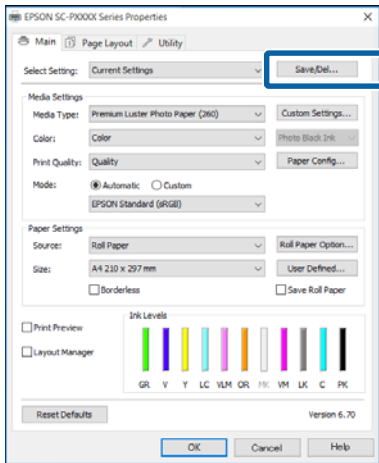

- 3 When you enter a name in **Name** and click **Save**, the settings are saved in **List**.

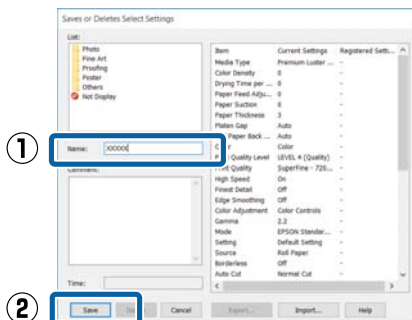

You can load the settings you have saved from **Select Setting** on the Main screen.

**Note:**

- ❑ You can save up to 100 settings.
- ❑ Select the settings you want to save, and then click **Export** to save them to a file. You can share the settings by clicking **Import** to import the saved file on another computer.
- ❑ Select the settings you want to delete, and then click **Delete**.

## Adding a Paper Type

This section explains how to register new paper information (Paper Configuration) for Print Quality and Paper Settings (Custom Settings). When settings have been registered, they are displayed in **Media Type** on the printer settings screen and can be selected.

**Important:**

When using commercially available paper in *Epson Color Calibration Utility*, make sure you register the paper information.

- 1 Display the printer driver's Main screen.  
[☞ "Printing \(Windows\)" on page 48](#)
- 2 Select **Media Type**, and then click **Paper Configuration**.

When registering commercially available paper as custom paper, select the Epson special media type that is closest to the paper you are using.

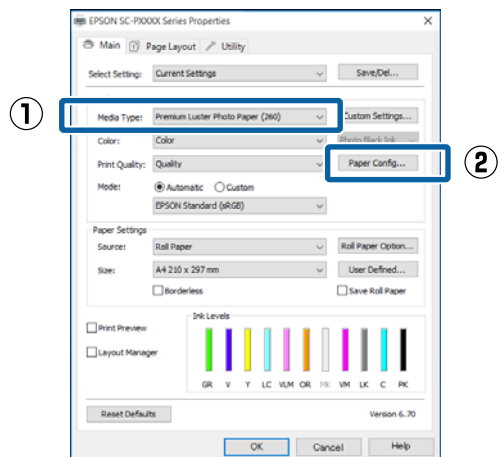

Using the Printer Driver(Windows)

**3** Adjust settings for the new custom media and click **OK**.

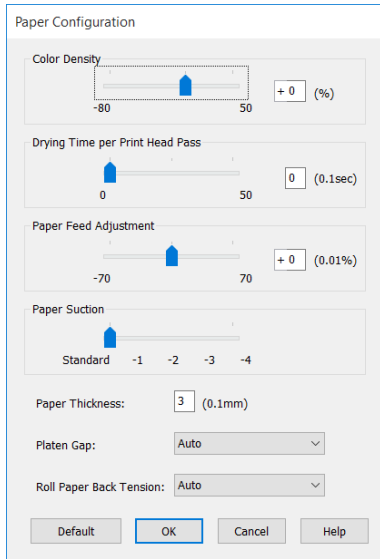

**4** Click **Custom Settings**.

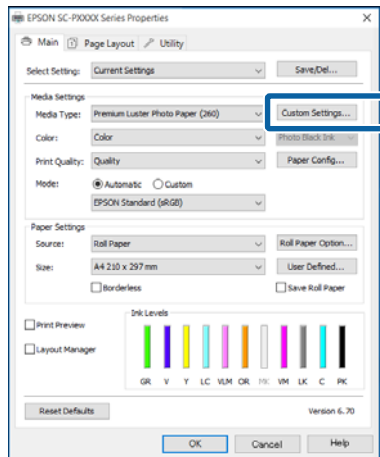

**5** When you enter a name in **Name** and click **Save**, the settings are saved in **List**.

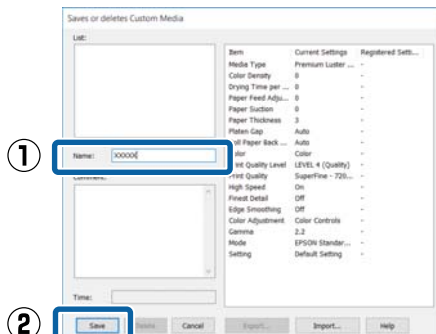

You can select saved settings from **Media Type** on the Main screen.

**Note:**

- You can save up to 100 settings.
- Select the settings you want to save, and then click **Export** to save them to a file. You can share the settings by clicking **Import** to import the saved file on another computer.
- Select the settings you want to delete, and then click **Delete**.

**Rearranging display items**

To display frequently used items right away, you can arrange **Select Setting**, **Media Type**, and **Paper Size** as follows.

- Hide unnecessary items.
- Rearrange in an order of most frequent use.
- Arrange in groups (folders).

**1** Go to the **Utility** tab and click **Menu Arrangement**.

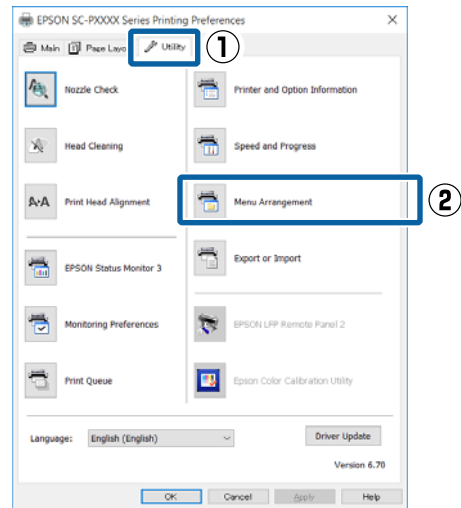

## Using the Printer Driver(Windows)

**2** Select **Edit Item**.

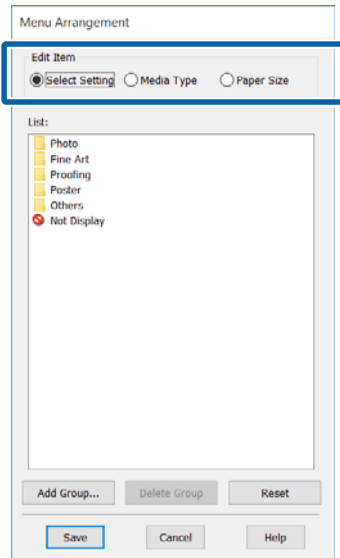

**4** Click **Save**.

**3** Order or group items in the **List** box.

- You can move and order items by dragging and dropping.
- To add a new group (folder), click **Add Group**.
- To delete a group (folder), click **Delete Group**.
- Drag and drop unnecessary items to **Not Display**.

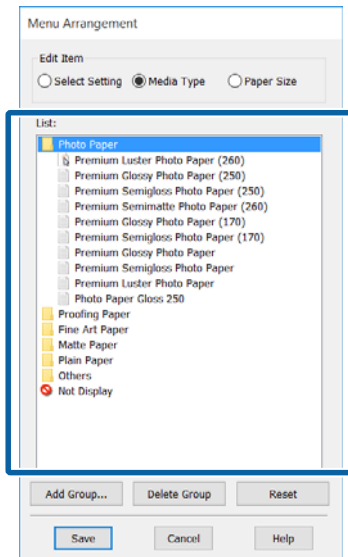

**Note:**

When **Delete Group** is performed, the group (folder) is deleted, however the settings in the deleted group (folder) remain. You also need to delete individually from **List**: in the save location.

Using the Printer Driver(Windows)

# Summary of the Utility Tab

You can perform the following maintenance functions from the printer driver's **Utility** tab.

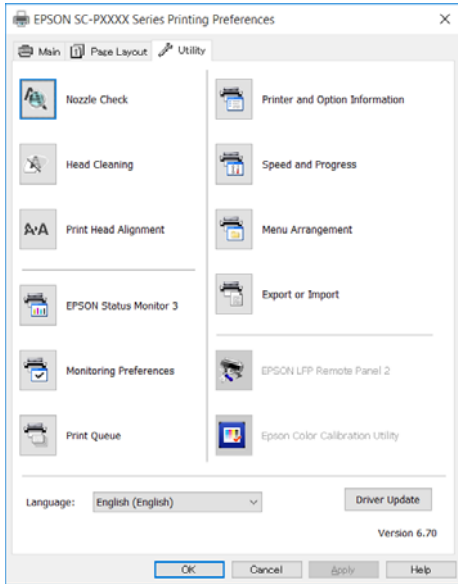

### Nozzle Check

This function prints a nozzle check pattern to check if the print head nozzles are clogged.

If you see banding or gaps in the print outs, perform head cleaning to clear any clogged nozzles.

[“Checking for clogged nozzles” on page 123](#)

### Head Cleaning

If you see banding or gaps in the print outs, perform head cleaning. Cleans the surface of the print head to improve the print quality.

[“Cleaning the print head” on page 124](#)

### Print Head Alignment

If the print results appear grainy or out of focus, perform Print Head Alignment. The Print Head Alignment function corrects print head gaps.

[“Adjusting print misalignments \(Head Alignment\)” on page 126](#)

### EPSON Status Monitor 3

You can check the printer's status, such as the remaining ink level and error messages, on the computer's screen.

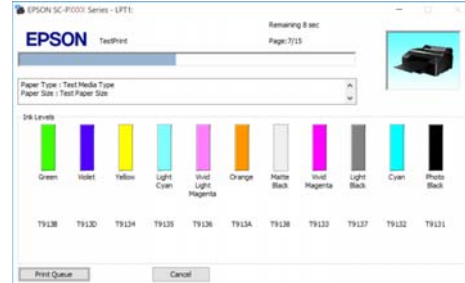

### Monitoring Preferences

You can select the error notifications displayed on the EPSON Status Monitor 3 screen, or register a shortcut for the Utility icon to the Taskbar.

**Note:**

*If you select the **Shortcut Icon** on the **Monitoring Preferences** screen, the Utility shortcut icon is displayed on the Windows Taskbar.*

*By right-clicking the icon, you can display the following menu and perform maintenance functions.*

*EPSON Status Monitor 3 starts when the printer name is clicked from the displayed menu.*

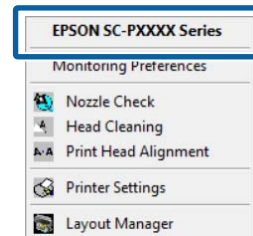

### Print Queue

You can display the list of all waiting jobs.

On the Print Queue screen, you can view information on the data waiting to be printed, delete and reprint these jobs.

### Printer and Option Information

Displays the ink set information. These settings should not normally be changed.

If you cannot acquire ink set information automatically, select an ink set according to the ink type that is installed in the printer.

### Speed and Progress

You can set various functions for printer driver basic operations.

## Using the Printer Driver(Windows)

### Menu Arrangement

You can arrange the display items of **Select Setting**, **Media Type**, and **Paper Size**. For example, you can reorder them by frequency of access.

 [“Rearranging display items” on page 59](#)

### Export or Import

You can export or import the printer driver settings. This function is useful when you want to make the same printer driver settings on multiple computers.

### EPSON LFP Remote Panel 2

You can configure custom paper settings and other settings. For details, see the EPSON LFP Remote Panel 2 help.

### Epson Color Calibration Utility

Start Epson Color Calibration Utility and perform calibration. See the Epson Color Calibration Utility manual for details.

**Note:**

*If EPSON LFP Remote Panel 2 and Epson Color Calibration Utility are grayed out, the applications are not installed on the computer being used.*

*You can download the latest applications from the Epson website.*

 [“Software on the Website” on page 27](#)

# Using the Printer Driver (Mac OS X)

## Displaying the Settings Screen

The display method of the printer driver setting screen may differ depending on the application or the OS version.

"Printing (Mac OS X)" on page 49

## Displaying Help

Click in the printer driver setting screen to display Help.

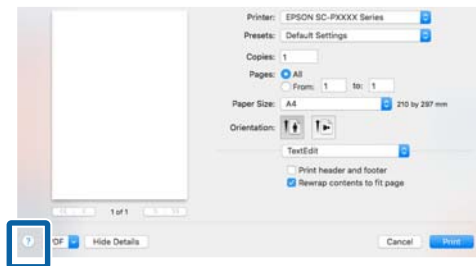

## Using Presets

You can enter a name in **Presets** and save the settings for frequently used setting information (items in Paper Size or Print Settings), and setting information for commercially available paper.

This allows you to easily load settings and repeatedly print using exactly the same settings.

**Note:**

*Settings saved in Presets can also be selected from Epson Color Calibration Utility. When using commercially available paper with the Epson Color Calibration Utility, we recommend saving settings in Presets.*

## Saving to Presets

- 1 Set each item in Paper Size and Print Settings that you want to save to the preset.

**When registering commercially available paper as custom paper**

- (1) Select **Print Settings** from the list, and then select the Epson special media type that is closest to the paper you are using from **Media Type**.
- (2) Select **Paper Configuration** from the list, and then make settings according to the paper you want to register. See the printer driver help for more details on each setting item.

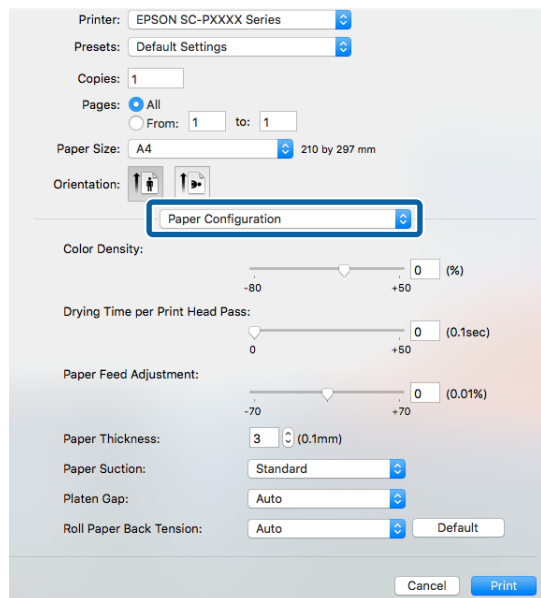

- 2 Click **Save Current Settings as Preset...** from **Presets**.

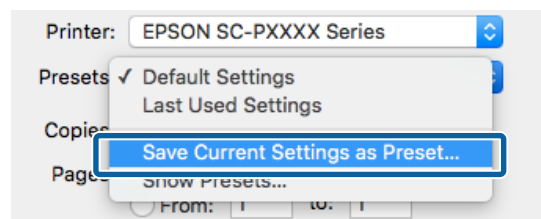

- 3 Enter a name, and then click **OK**.

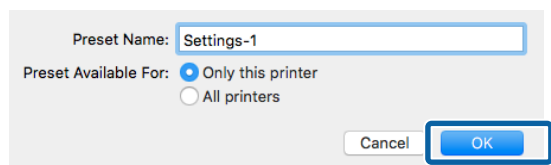

Using the Printer Driver(Mac OS X)

**Note:**  
When **All printers** is selected from **Preset Available For**, you can select the saved **Preset** from all printer drivers installed on your computer.

The settings are saved to **Presets**.  
You can then select the settings you saved from **Presets**.

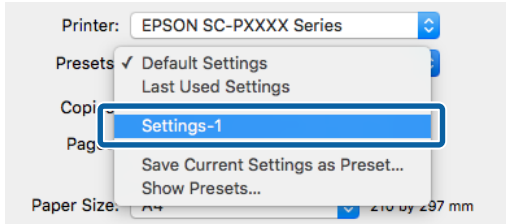

**Deleting from Presets**

**1** On the Print screen, select **Show Presets...** from **Presets**.

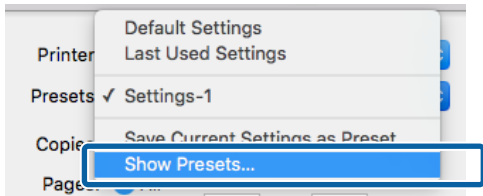

**2** Select the setting you want to delete, click **Delete**, and then click **OK**.

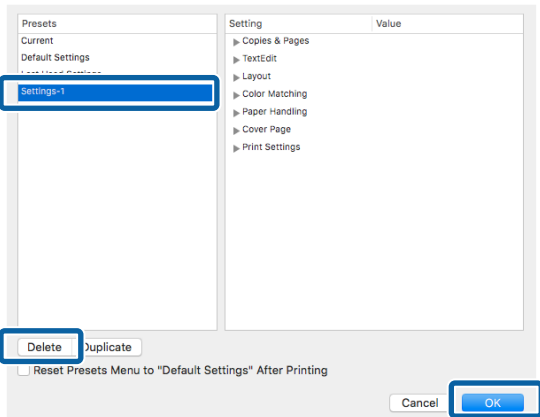

**Using Epson Printer Utility 4**

You can perform maintenance tasks such as Nozzle Check or Head Cleaning by using Epson Printer Utility 4. This utility is installed automatically when you install the printer driver.

**Starting Epson Printer Utility 4**

- 1** Click the Apple menu - **System Preferences - Printers & Scanners** (or **Print & Fax**).
- 2** Select the printer and click **Options & Supplies > Utility > Open Printer Utility**.

**Epson Printer Utility 4 Functions**

You can perform the following maintenance functions from Epson Printer Utility 4.





## Using the Printer Driver(Mac OS X)

### EPSON Status Monitor

You can check the printer's status, such as the remaining ink level and error messages, on the computer's screen.



### Nozzle Check

This function prints a nozzle check pattern to check if the print head nozzles are clogged.

If you see banding or gaps in the print outs, perform head cleaning to clear any clogged nozzles.

[“Checking for clogged nozzles” on page 123](#)

### Head Cleaning

If you see banding or gaps in the print outs, perform head cleaning. Cleans the surface of the print head to improve the print quality.

[“Cleaning the print head” on page 124](#)

### Print Head Alignment

Perform print head alignment if the print results appear grainy or blurred. The Print Head Alignment function corrects print head gaps.

[“Adjusting print misalignments \(Head Alignment\)” on page 126](#)

### EPSON LFP Remote Panel 2

You can configure custom paper settings and other settings. For details, see the EPSON LFP Remote Panel 2 help.

#### **Note:**

If EPSON LFP Remote Panel 2 is grayed out, the application is not installed on the computer being used.

You can download the latest applications from the Epson website.

[“Software on the Website” on page 27](#)

Printing Varieties

# Printing Varieties

## Auto Color Adjustment by PhotoEnhance (Windows Only)

The printer driver for this printer comes with the Epson proprietary function PhotoEnhance that makes the most efficient use of the color reproduction area, corrects image data to improve colors before printing.

By using PhotoEnhance, you can correct photo colors to match the subject types such as people, scenery, or night view. You can print color data in sepia or black and white. Colors are automatically corrected simply by selecting the print mode.

**Note:**  
It is recommended that you use images with a color space of sRGB.

**1** When using applications featuring a color management function, specify how to adjust colors from these applications.

When using applications without a color management function, start from step 2.

Depending on the type of the application, make the settings following the table below.

Adobe Photoshop CS3 or later  
 Adobe Photoshop Elements 6.0 or later  
 Adobe Photoshop Lightroom 1 or later

OS	Color Management Settings
Windows 10, Windows 8.1, Windows 8, Windows 7, Windows Vista	Printer Manages Colors
Windows XP (Service Pack 2 or later and .NET 3.0 or later)	

OS	Color Management Settings
Windows XP (other than the above)	No Color Management

In other applications, set **No Color Management**.

**Note:**  
For information on supported platforms, see the website for the application in question.

Setting example for Adobe Photoshop CS5

Open the **Print** screen.

Select **Color Management** and then **Document**. Select **Printer Manages Colors** as the **Color Handling** setting, and then click **Print**.

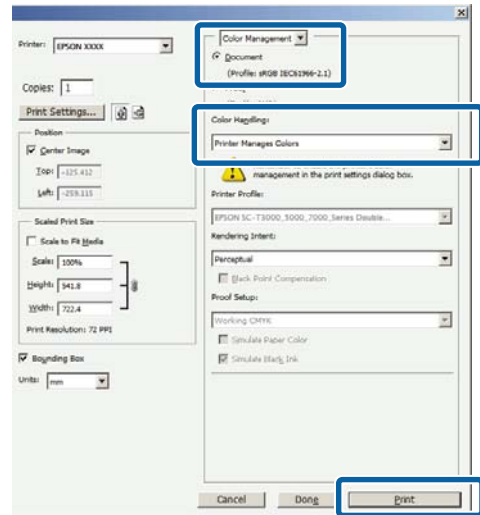

**2** Display the printer driver's **Main** screen.  
 ☞ ["Printing \(Windows\)" on page 48](#)

Printing Varieties

**3** Select **Custom** from **Mode**, and then select **PhotoEnhance**.

To make more detailed adjustments, click **Advanced**, and then proceed to step 4.

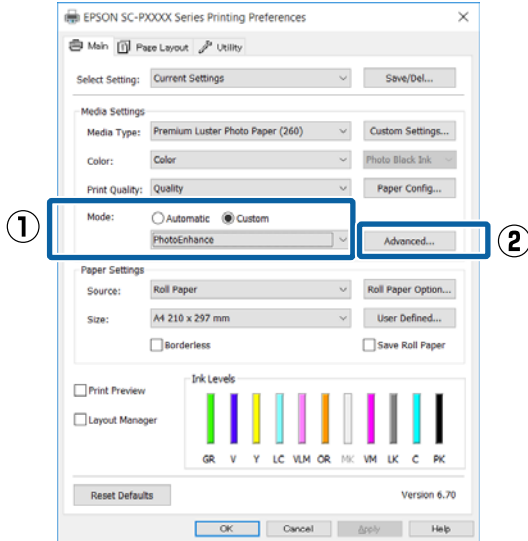

**4** On the **PhotoEnhance** screen, you can set effects to apply to the print data.

See the printer driver help for more details on each item.

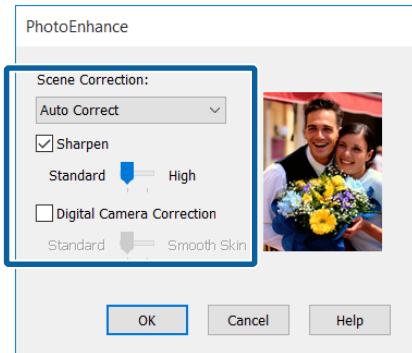

**5** Check other settings, and then start printing.

## Correct color and print

The printer driver automatically and internally corrects colors to match the color space. You can select from the following color correction modes.

- Charts and Graphs**  
Performs color correction to sharpen your images based on the sRGB space.
- EPSON Standard (sRGB)**  
Optimizes the sRGB space and corrects the color.
- Adobe RGB**  
Adobe RGB Optimizes the sRGB space and corrects the color.

Note that if you click **Advanced** when one of the above color processing options is selected, you can fine-tune Gamma, Brightness, Contrast, Saturation, and color balance for the selected option.

Use this option when the application in use does not have a color correction function.

### Making Settings in Windows

**1** When using applications featuring a color management function, specify how to adjust colors from these applications.

When using applications without a color management function, start from step 2.

Depending on the type of the application, make the settings following the table below.

Adobe Photoshop CS3 or later  
 Adobe Photoshop Elements 6.0 or later  
 Adobe Photoshop Lightroom 1 or later

OS	Color Management Settings
Windows 10, Windows 8.1, Windows 8, Windows 7, Windows Vista	Printer Manages Colors
Windows XP (Service Pack 2 or later and .NET 3.0 or later)	

### Printing Varieties

OS	Color Management Settings
Windows XP (other than the above)	No Color Management

In other applications, set **No Color Management**.

**Note:**  
For information on supported platforms, see the website for the application in question.

Setting example for Adobe Photoshop CS5

Open the **Print** screen.

Select **Color Management** and then **Document**. Select **Printer Manages Colors** as the **Color Handling** setting, and then click **Print**.

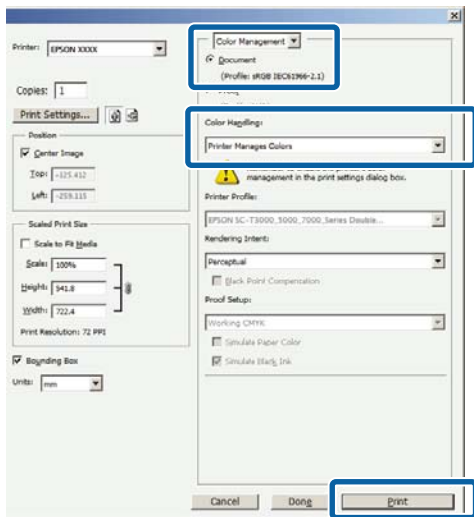

**2** Display the printer driver's **Main** screen.  
 ["Printing \(Windows\)" on page 48](#)

**3** Select **Custom** from **Mode**, and then select **Color Controls**.

To make more detailed adjustments, click **Advanced**, and then proceed to step 4.

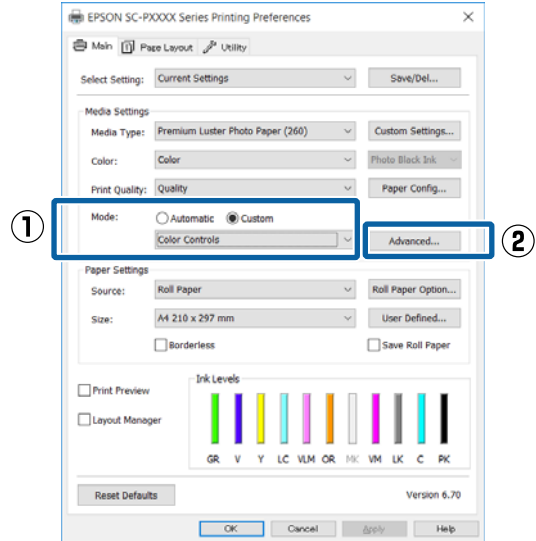

**4** Make the necessary settings.

See the printer driver help for more details on each item.

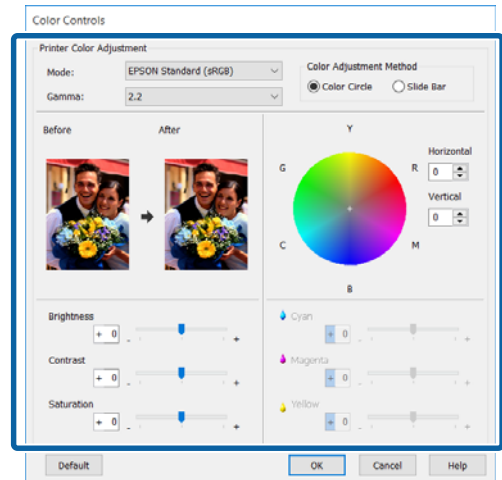

**Note:**  
You can adjust the correction value by checking the sample image on the left side of the screen. You can also use the color circle to fine-tune the color balance.

**5** Check other settings, and then start printing.

## Printing Varieties

### Making Settings for Mac OS X

**1** When using applications featuring a color management function, specify how to adjust colors from these applications.

When using applications without a color management function, start from step 2.

When using the following applications, select the **Printer Manages Colors** color management option.

- Adobe Photoshop CS3 or later
- Adobe Photoshop Elements 6 or later
- Adobe Photoshop Lightroom 1 or later

In other applications, set **No Color Management**.

**Note:**

For information on supported platforms, see the website for the application in question.

Setting example for Adobe Photoshop CS5

Open the **Print** screen.

Select **Color Management** and then **Document**. Select **Printer Manages Colors** as the **Color Handling** setting, and then click **Print**.

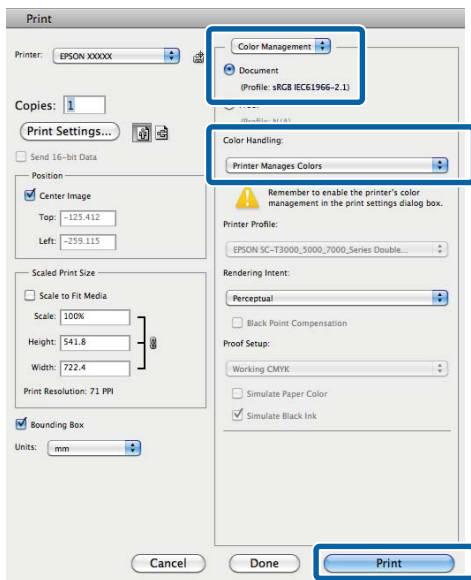

**2** Display the Print screen.

["Printing \(Mac OS X\)" on page 49](#)

**3** Select **Color Matching** from the list, and then click **EPSON Color Controls**.

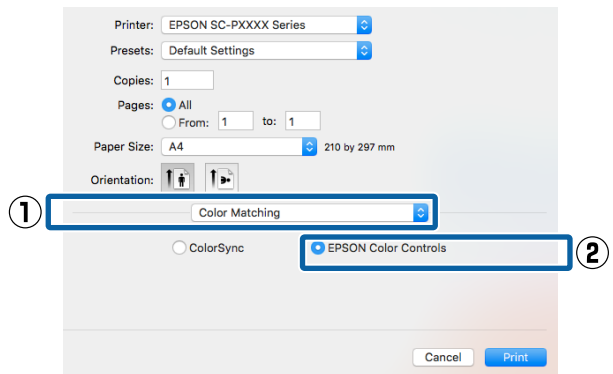

**Note:**

*EPSON Color Controls will not be available in the following applications if step 1 is omitted.*

- Adobe Photoshop CS3 or later
- Adobe Photoshop Lightroom 1 or later
- Adobe Photoshop Elements 6 or later

**4** Select **Print Settings** from the list, and then select **Color Controls** as the **Color Settings** setting. When adjusting the parameters manually, click **Advanced Color Settings**.

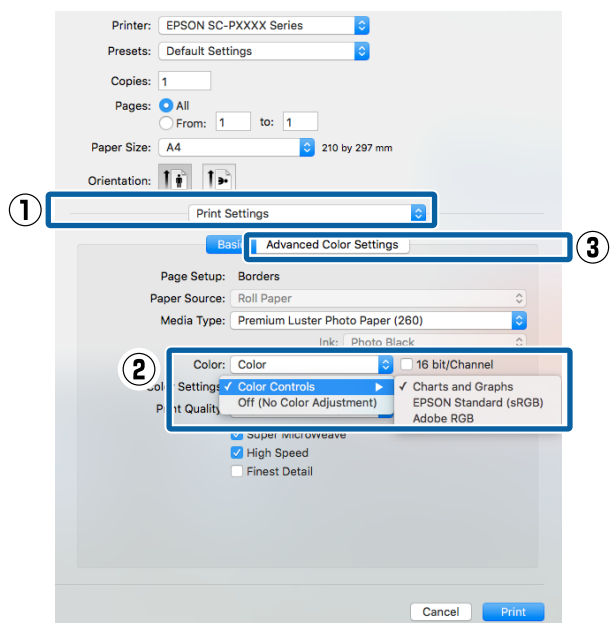

Printing Varieties

- 5 Make the necessary settings.  
See the printer driver help for more details on each item.

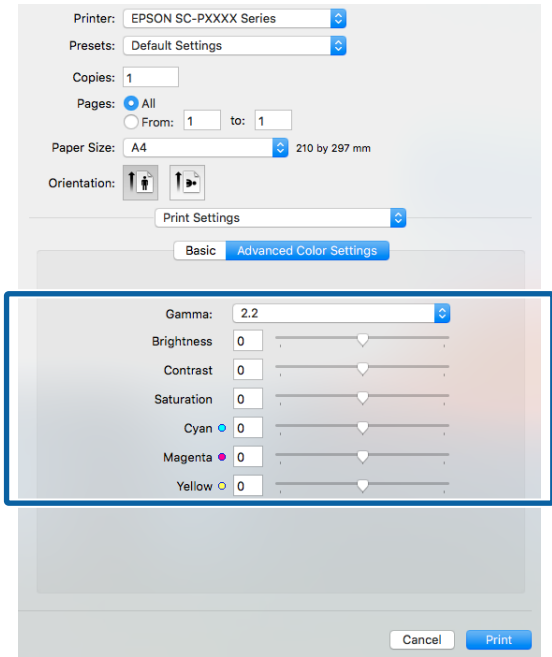

- 6 Check other settings, and then start printing.

## Printing Black and White Photos

You can print black and white photos with rich gradation by adjusting the image data color by the printer driver. You can correct image data when printing without processing the data from applications. The original data is not affected.

You cannot select **Advanced B&W Photo** in the following instances. When printing in black and white, select **Black** (Windows) or **Grayscale** (Mac OS X).

- When using the Violet ink set
- When using Singleweight Matte Paper, Photo Quality Ink Jet Paper, or Plain Paper

**Note:**

*It is recommended that you use images with a color space of sRGB.*

### Making Settings in Windows

- 1 When using applications featuring a color management function, specify how to adjust colors from these applications.

When using applications without a color management function, start from step 2.

Depending on the type of the application, make the settings following the table below.

- Adobe Photoshop CS3 or later
- Adobe Photoshop Elements 6.0 or later
- Adobe Photoshop Lightroom 1 or later

OS	Color Management Settings
Windows 10, Windows 8.1, Windows 8, Windows 7, Windows Vista	Printer Manages Colors
Windows XP (Service Pack 2 or later and .NET 3.0 or later)	

### Printing Varieties

OS	Color Management Settings
Windows XP (other than the above)	No Color Management

In other applications, set **No Color Management**.

**Note:**  
For information on supported platforms, see the website for the application in question.

Setting example for Adobe Photoshop CS5

Open the **Print** screen.

Select **Color Management** and then **Document**. Select **Printer Manages Colors** or **No Color Management** as the **Color Handling** setting, and then click **Print**.

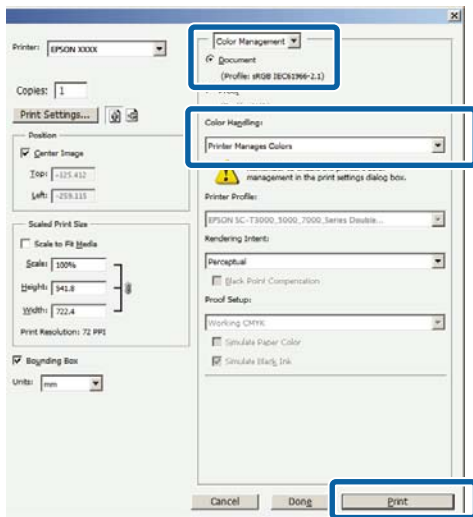

**2** Display the printer driver's **Main** screen.

☞ ["Printing \(Windows\)" on page 48](#)

**3** Select **Color** from **Advanced B&W Photo**.

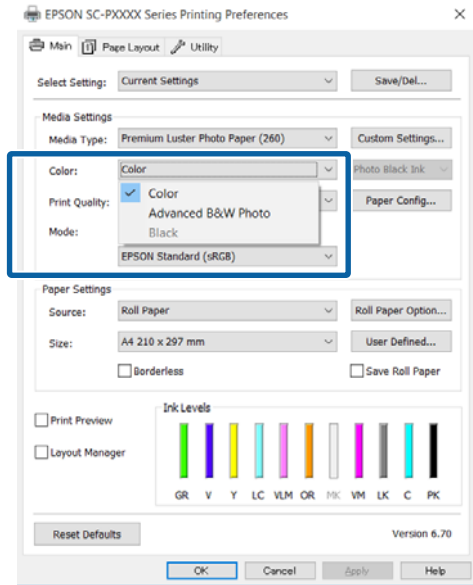

To make detailed adjustments, proceed to step 4. If you do not want to make adjustments, proceed to step 6.

**4** Select **Custom** from **Mode**, and then click **Advanced**.

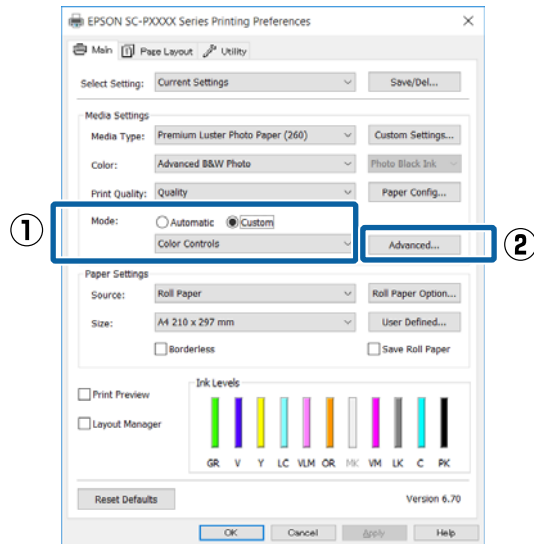



## Printing Varieties

- 5 Make the necessary settings.  
See the printer driver help for more details on each item.

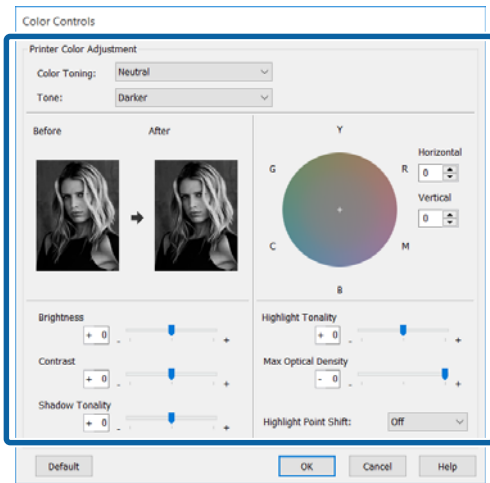

- 6 Check other settings, and then start printing.

### Making Settings for Mac OS X

- 1 When using applications featuring a color management function, specify how to adjust colors from these applications.

When using the following applications, select the **Printer Manages Colors** color management option.

Adobe Photoshop CS3 or later  
 Adobe Photoshop Elements 6 or later  
 Adobe Photoshop Lightroom 1 or later

In other applications, set **No Color Management**.

**Note:**

For information on supported platforms, see the website for the application in question.

Setting example for Adobe Photoshop CS5

Open the **Print** screen.

Select **Color Management** and then **Document**. Select **Printer Manages Colors** as the **Color Handling** setting, and then click **Print**.

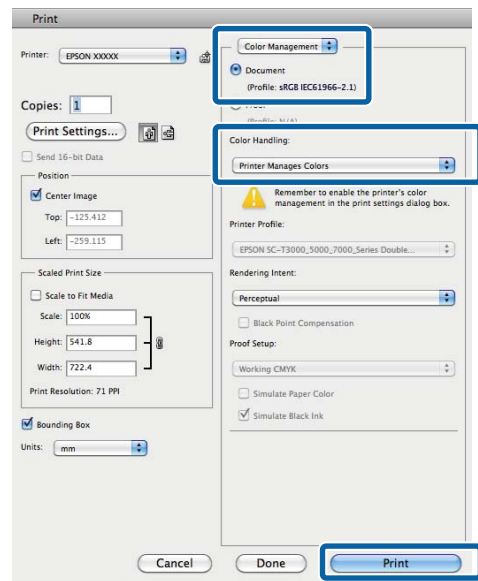

- 2 Display the Print screen, select **Print Settings** from the list, and then select **Advanced B&W Photo** as the **Color**.

[“Printing \(Mac OS X\)” on page 49](#)

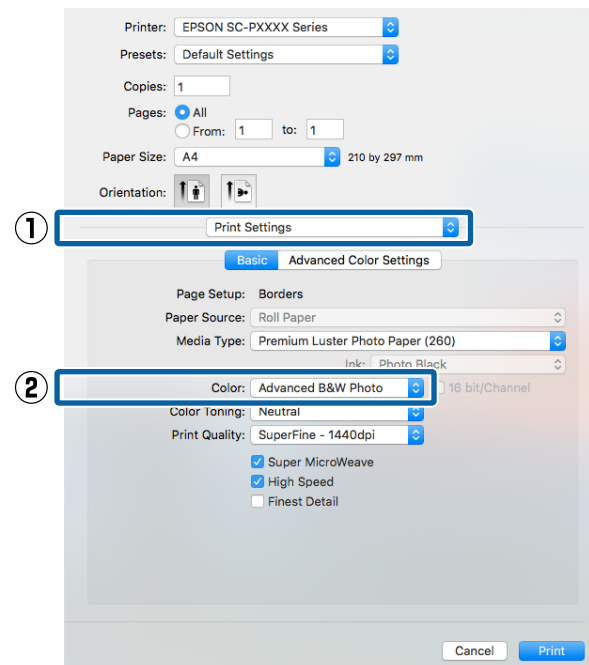



Printing Varieties

**3** Click **Advanced Color Settings**.

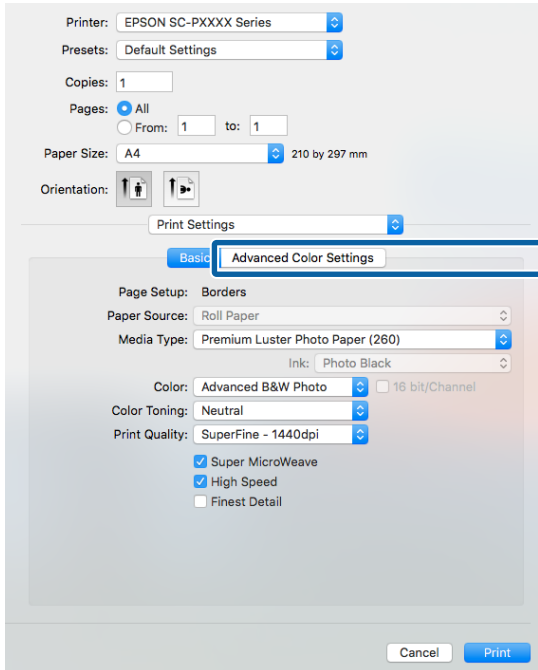

**4** Make the necessary settings.

See the printer driver help for more details on each item.

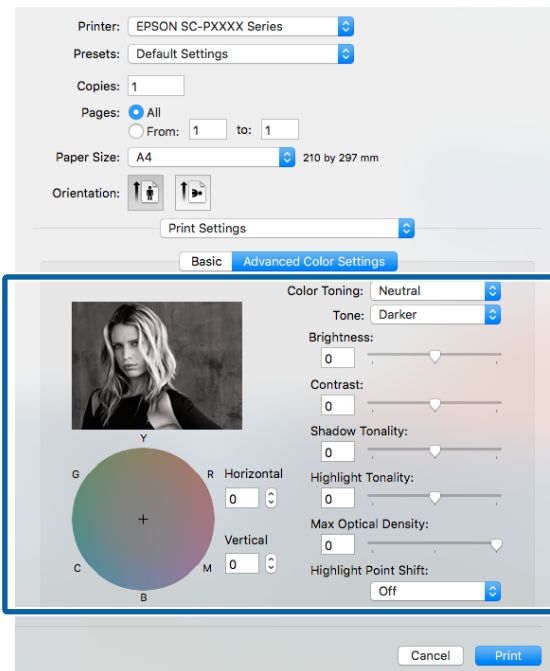

**5** Check other settings, and then start printing.

## Borderless Printing

You can print your data without margins on the paper.

The types of borderless printing you can choose vary as shown below depending on the media type.

Roll Paper: Borderless for all edges\*, no margins for the left and right

Cut Sheets: No margins for the left and right only

(Borderless printing is not available with poster board.)

\* When the optional SpectroProofer is installed, borderless printing for all edges cannot be performed.

When printing borderless for all edges, you can also configure the cutting operation.

[☞ “About Roll Paper Cutting” on page 75](#)

When performing left and right borderless printing, margins appear on the top and bottom of the paper.

Top and bottom margin values [☞ “Printable area” on page 52](#)

## Types of Borderless Printing Methods

You can perform borderless printing using the following two methods.

- ❑ **Auto Expand**  
The printer driver enlarges the print data to a size slightly larger than the paper size and prints the enlarged image. The sections which are beyond the paper edges are not printed; therefore, resulting in borderless printing.  
Use settings such as Page Setup in the applications to set the size of the image data as follows.
- Match the paper size and page setting for the print data.
- If the application has margin settings, set the margins to 0 mm.

### Printing Varieties

- Make the image data as large as the paper size.

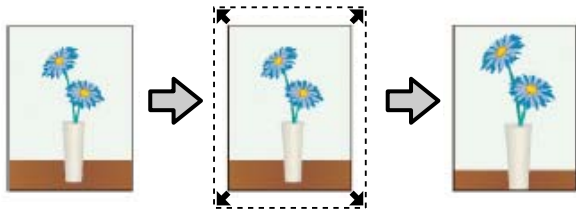

- Retain Size**  
Create the print data larger than the paper size in the applications to produce borderless output. The printer driver does not enlarge the image data. Use settings such as Page Setup in the applications to set the size of the image data as follows.

- Create print data larger than its actual print size by 3 mm on the left and right (6 mm in total).
- If the application has margin settings, set the margins to 0 mm.
- Make the image data as large as the paper size.

Select this setting if you want to avoid image enlargement by the printer driver.

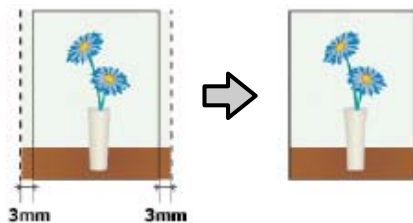

## Supported Media Sizes for Borderless Printing

The following media sizes are supported for borderless printing.

The supported paper sizes vary depending on if you are using roll paper or cut sheets.

Supported paper widths	Roll Paper	Cut sheet
A4/210 mm	✓	✓
A3/297 mm	✓	✓
Super A3/B/329 mm	✓	✓

Supported paper widths	Roll Paper	Cut sheet
SuperW A3/329 mm	✓	✓
A2/420 mm*	✓	-
US B/11 inch*	✓	-
US C/17 inch	✓	✓
8 inch*	✓	-
10 inch	✓	✓
16 inch	✓	✓
30 cm	✓	✓

\* You can perform borderless printing only when using the borderless printing spacer supplied with the printer and printing on roll paper with a 2-inch core. [☞ "Removing and installing the spacer" on page 32](#)

Depending on the media type, the print quality may decline or borderless printing cannot be selected.

[☞ "Epson Special Media Table" on page 163](#)

[☞ "Supported Commercially Available Paper" on page 173](#)

Printing Varieties

About Roll Paper Cutting

When performing borderless printing on roll paper, you can specify whether it is left and right borderless printing or all edges borderless printing, and how to cut the paper in the printer driver's **Roll Paper Option**. The cutting operation for each value is shown in the following chart.

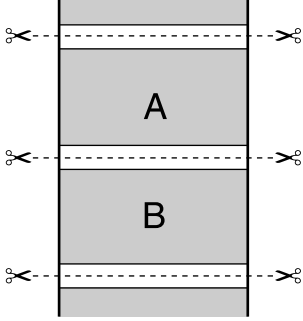
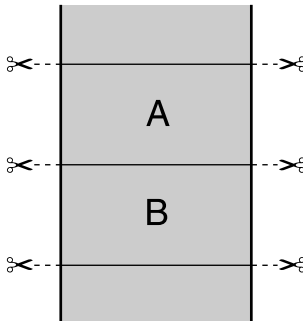
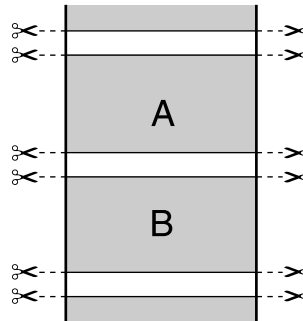
Printer driver settings	Normal Cut	Single Cut	Double Cut
Cutting Operation			
Explanation	<p>The default printer driver setting is <b>Normal Cut</b>.</p>	<ul style="list-style-type: none"> <li>❑ The top area may become slightly uneven depending on the image since the print operation stops while cutting the top edge of the roll paper.</li> <li>❑ If the cut position is misaligned slightly, small parts of the image may be shown on the top or bottom of the adjacent pages. If this occurs, perform <b>Adjust Cut Position</b>.  <a href="#">👉 "Maintenance" on page 111</a></li> <li>❑ When you print one page only or print one page multiple times, the operation is the same as that for <b>Double Cut</b>. When continuously printing multiple sheets, the printer cuts 1 mm inside on the top edge of the first page and the bottom edge of the subsequent pages to avoid showing margins.</li> </ul>	<ul style="list-style-type: none"> <li>❑ The top area may become slightly uneven depending on the image since the print operation stops while cutting the top edge of the roll paper.</li> <li>❑ The printed paper is approximately 2 mm shorter than the specified size since the printer cuts the paper inside the image to avoid showing top and bottom margins.</li> <li>❑ After cutting the bottom edge of the preceding page, the printer feeds the paper, and then cuts the top edge of the following page. Although this produces 80 to 127 mm cut-off pieces, the cut is more accurate.</li> </ul>

Printing Varieties

# Setting Procedures for Printing

## Making Settings in Windows

**1** When the printer driver's **Main** screen is displayed, you can configure various settings required for printing such as **Media Type**, **Source**, **Size**.

"Printing (Windows)" on page 48

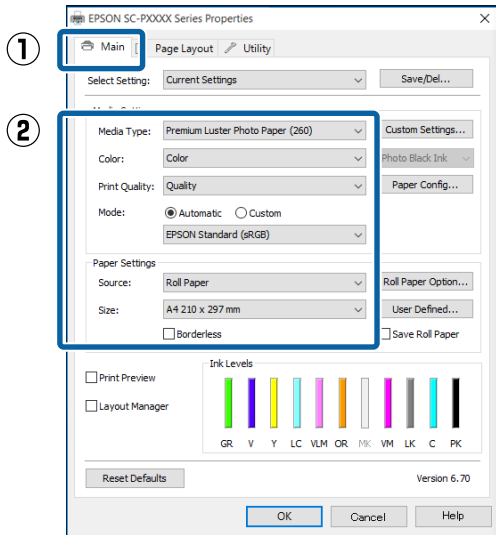

**2** Select **Borderless**, and then click **Expansion**. You cannot choose the expansion amount when **Roll Paper** or **Roll Paper (Banner)** is selected for **Source**.

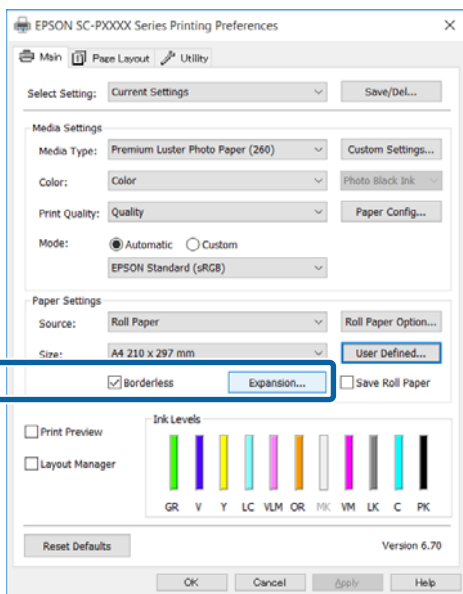

**3** Select **Auto Expand** or **Retain Size** as the **Method of Enlargement**.

If you select **Auto Expand**, set how much of the image goes beyond the edge of the paper as shown below.

Max : 3 mm for left and 5 mm for right (the image shifts 1 mm to the right)

Mid : 3 mm for left and right

Min : 1.5 mm for left and right

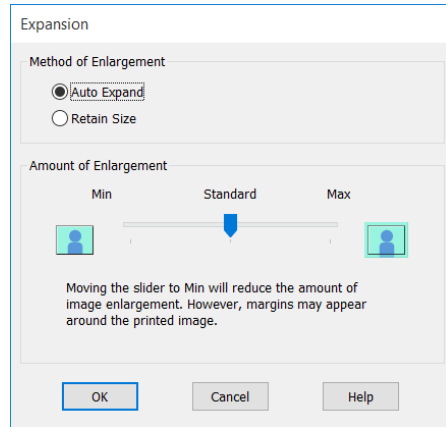

**Note:**  
Moving the slider towards **Min** decreases the image enlargement ratio. Therefore, some margins may appear at the edges of the paper depending on the paper and printing environment.

Printing Varieties

**4** When using roll paper, click **Roll Paper Option**, and then set **Auto Cut** option.

[“About Roll Paper Cutting” on page 75](#)

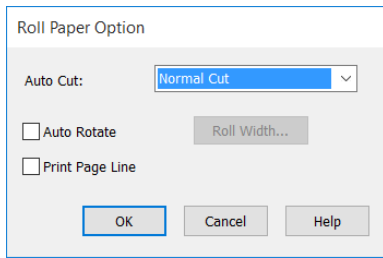
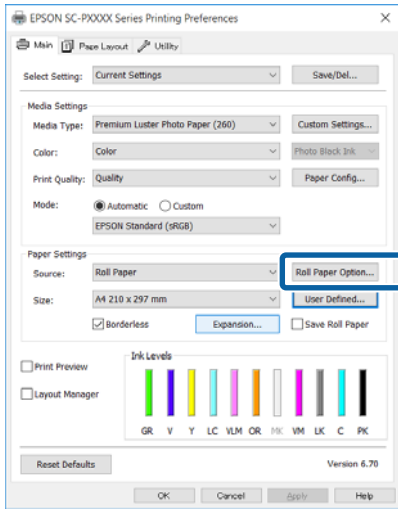

**5** Check other settings, and then start printing.

**Making Settings for Mac OS X**

**1** Open the Print screen and select the paper size from the **Paper Size** option, and then select a borderless printing method.

[“Printing \(Mac OS X\)” on page 49](#)

The selections for borderless printing methods are displayed as shown below.

- xxxx (Borderless, Auto Expand)
- xxxx (Borderless, Retain Size - Roll Paper)
- xxxx (Borderless, Retain Size - Sheet)
- xxxx (Borderless, Retain Size, Maximum - Sheet)

Where XXXX is the actual paper size, such as A4.

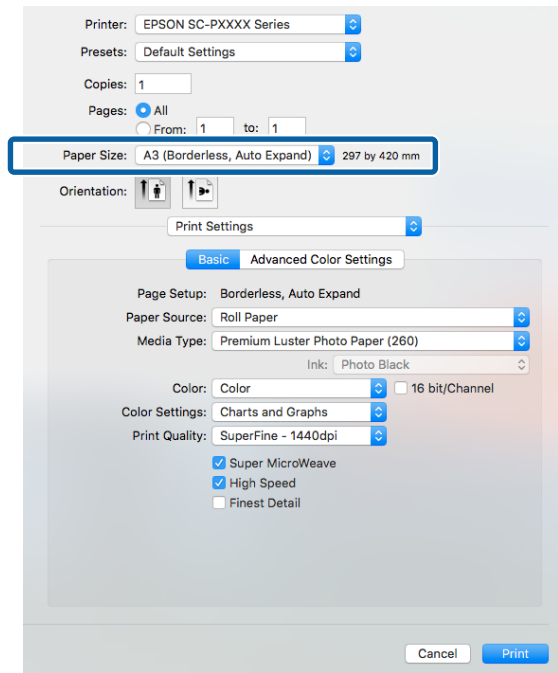

**Note:**  
*If page setting options are not available in the application's print dialog, display the page settings dialog.*

**2** Select **Page Layout Settings** from the list, and then set **Roll Paper Option** or **Expansion**.

See the following for more details on **Auto Cut** from **Roll Paper Option**.

[“About Roll Paper Cutting” on page 75](#)

**Expansion** is only available when **Auto Expand** is selected from **Paper Size**. The following shows the values for each item.

Max : 3 mm for left and 5 mm for right (the image shifts 1 mm to the right)

Standard : 3 mm for left and right

Min : 1.5 mm for left and right

Printing Varieties

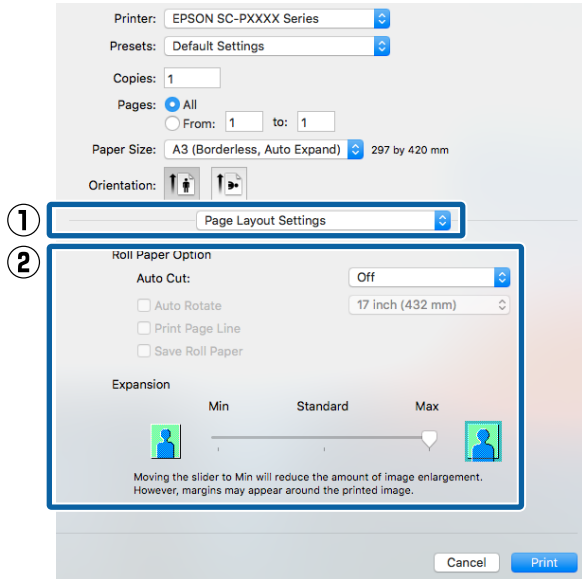

**Note:**  
 Moving the slider towards **Min** decreases the image enlargement ratio. Therefore, some margins may appear at the edges of the paper depending on the paper and printing environment.

**3** Check other settings, and then start printing.

## Enlarged/Reduced Printing

You can enlarge or reduce the size of your data. There are three setting methods.

- Fit to Page printing**  
 Automatically enlarges or reduces the image size to fit the paper size.

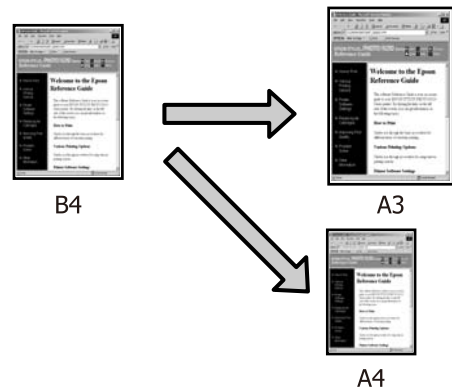

- Fit to Roll Paper Width (Windows only)**  
 Automatically enlarges or reduces the image size to fit the roll paper width.

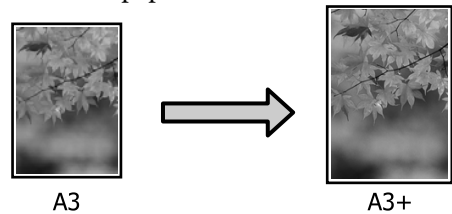

- Custom**  
 You can specify the enlargement or reduction ratio. Use this method for a non-standard paper size.

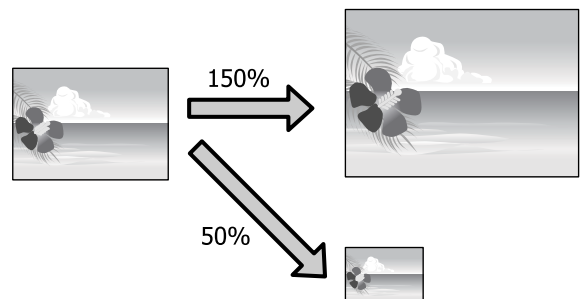

## Printing Varieties

### Fit to Page/Scale to fit paper size

#### Making Settings in Windows

**1** When the printer driver's **Page Layout** screen is displayed, set the same paper size as the data's paper size in **Page Size** or **Paper Size**.

[“Printing \(Windows\)” on page 48](#)

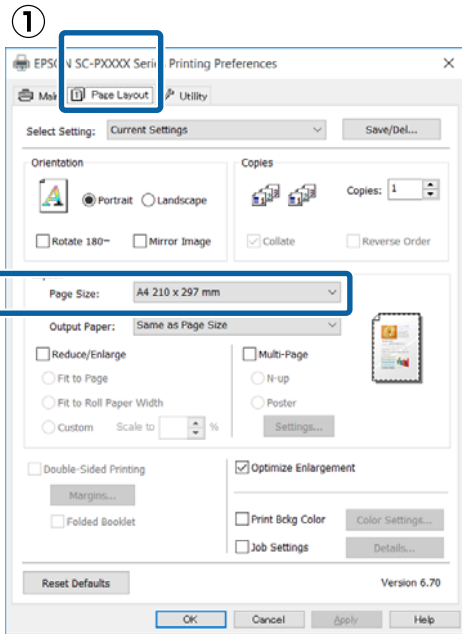

**2** Select the size of the paper loaded in the printer from the **Output Paper** list.

**Fit to Page** is selected as **Reduce/Enlarge**.

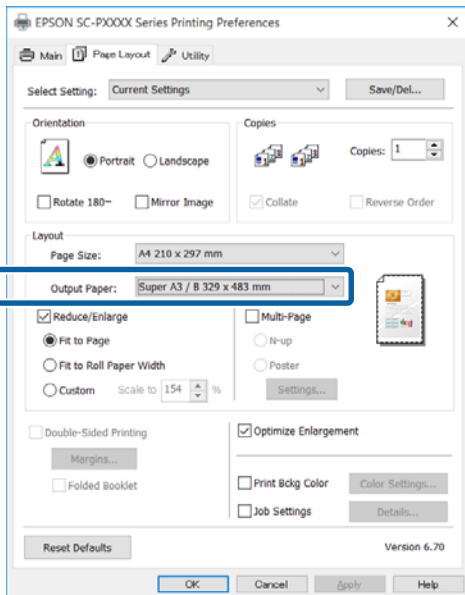

**3** Check other settings, and then start printing.

#### Making Settings for Mac OS X

**1** Open the Print screen, select **Paper Handling** from the list, and then check **Scale to fit paper size**.

[“Printing \(Mac OS X\)” on page 49](#)

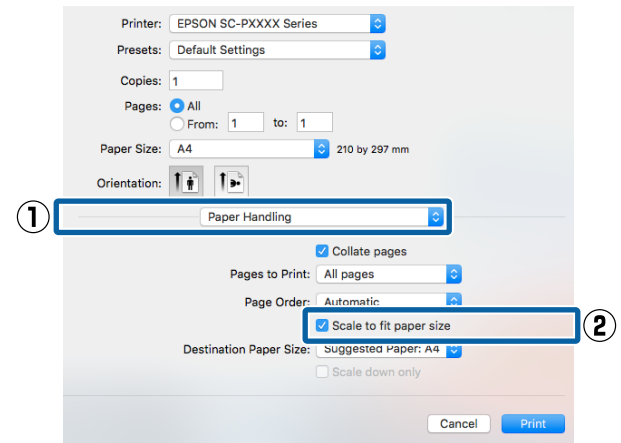

**2** Select the size of the paper loaded in the printer as the **Destination Paper Size**.

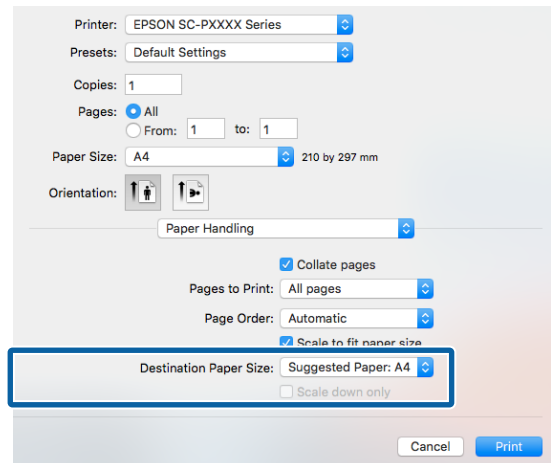

**Note:**

*When performing enlarged printing, clear the **Scale down only** check box.*

**3** Check other settings, and then start printing.

## Printing Varieties

### Fit to Roll Paper Width (Windows Only)

- 1 Display the printer driver **Main** tab and select **Roll Paper** for **Source**.  
[“Printing \(Windows\)” on page 48](#)
- 2 Display the **Page Layout** tab and choose a **Page Size** that matches the page size used in the document size.

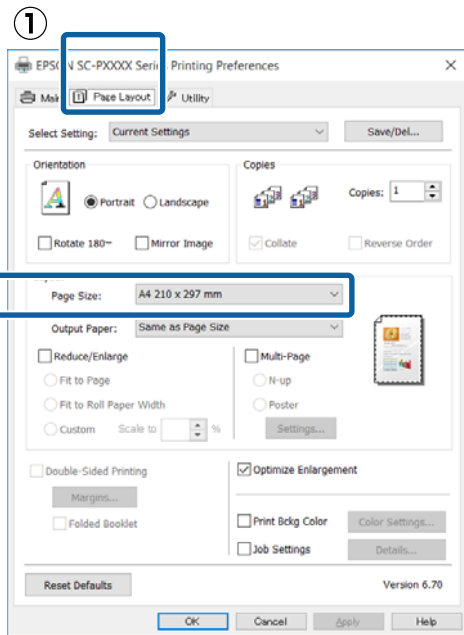

- 3 Select the size of the paper loaded in the printer from the **Output Paper** list.  
**Fit to Page** is selected as **Reduce/Enlarge**.

- 4 Select **Fit to Roll Paper Width**.

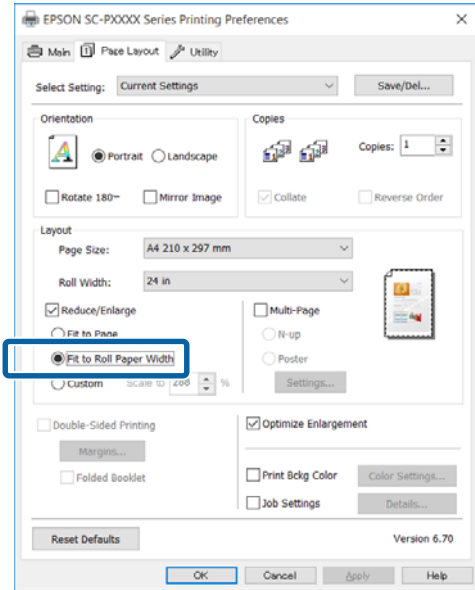

- 5 Select the width of the roll paper loaded in the printer from the **Roll Width** list.

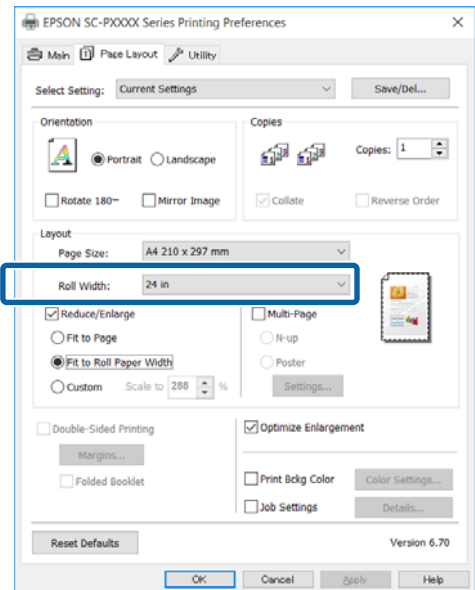

- 6 Check other settings, and then start printing.

### Custom Scale Setting

#### Making Settings in Windows

- 1 When the printer driver's **Page Layout** screen is displayed, set the same paper size as the data's paper size in **Page Size** or **Paper Size**.

[“Printing \(Windows\)” on page 48](#)



## Printing Varieties

**2** Select the size of the paper loaded in the printer from the **Output Paper** list.

**Fit to Page** is selected as **Reduce/Enlarge**.

**3** Select **Custom**, and then set the **Scale** to value.

Enter a value directly or click the arrows to the right of the scale box to set the value.

Select the scale within a range of 10 to 650 %.

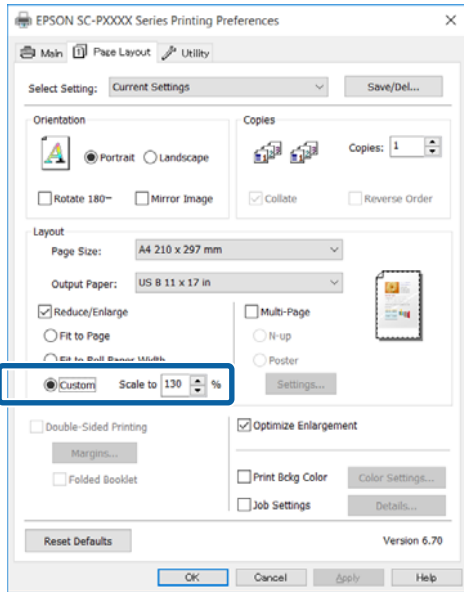

**4** Check other settings, and then start printing.

### Making Settings for Mac OS X

**1** When the Print screen is displayed, select the size of the paper loaded in the printer from the **Paper Size** list.

[“Printing \(Mac OS X\)” on page 49](#)

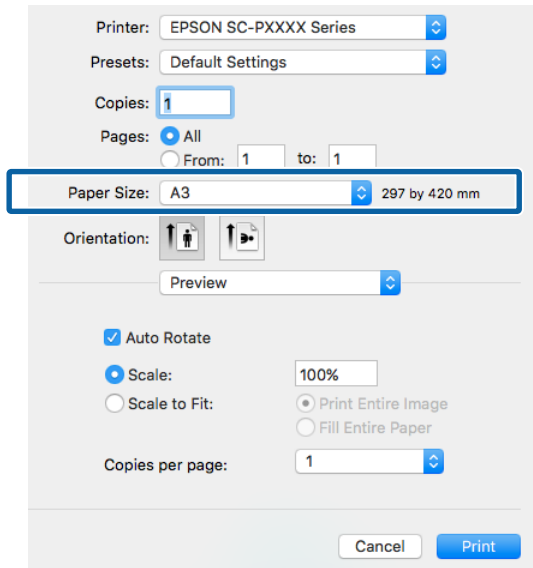

**2** Click **Scale**, and then enter the scale.

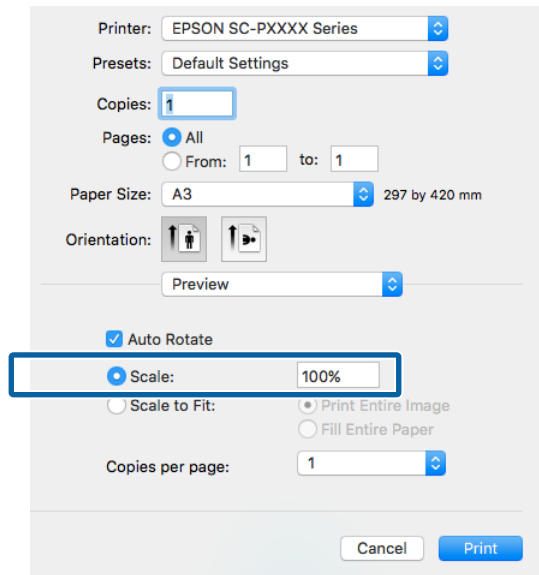

If the Print screen in the application you are using does not have an input item for the scale that you want to use, display the Page Setup screen and make settings.

[“Printing \(Mac OS X\)” on page 49](#)

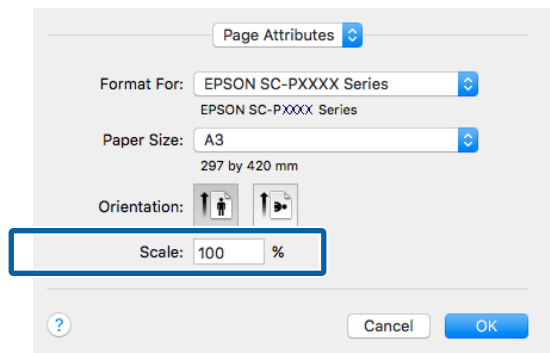

## Printing Varieties

### Multi-Page Printing

You can print multiple pages of your document on one sheet of paper.

If you print continuous data prepared at A4 size, it is printed as shown below.

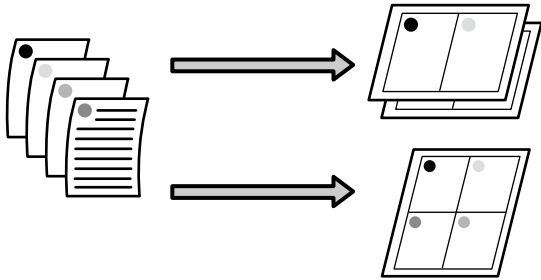

**Note:**

- In Windows, you cannot use the Multi-Page printing function when performing borderless printing.
- In Windows, you can use the reduce/enlarge function (Fit to Page) to print the data on different sizes of paper.

[“Enlarged/Reduced Printing” on page 78](#)

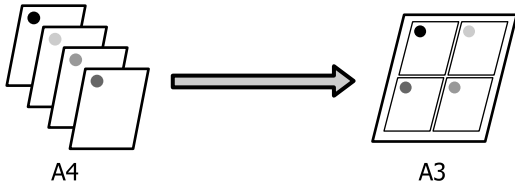

### Making Settings in Windows

**1** When the printer driver's **Page Layout** screen is displayed, select the **Multi-Page** check box, select **N-up**, and then click **Settings**.

[“Printing \(Windows\)” on page 48](#)

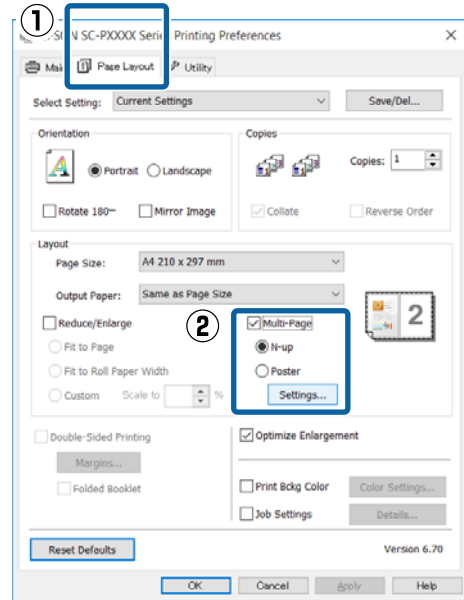

**2** In the **Print Layout** screen, specify the number of pages per sheet and the page order.

If the **Print page frames** check box is selected, page frames are printed on each page.

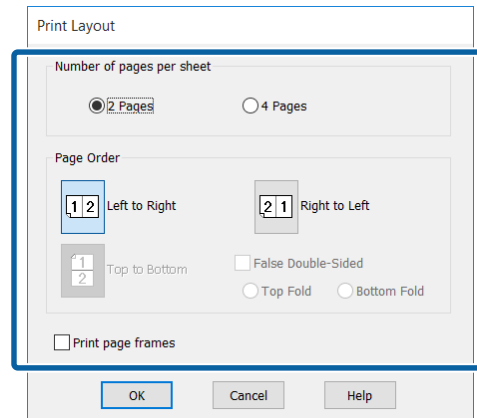

**3** Check other settings, and then start printing.

Printing Varieties

**Making Settings for Mac OS X**

**1** When the Print screen is displayed, select **Layout** from the list, and then specify the number of pages per sheet and so on.

[“Printing \(Mac OS X\)” on page 49](#)

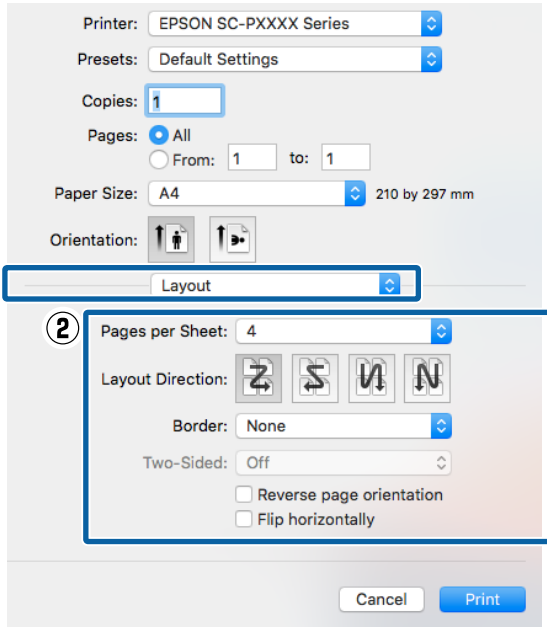

**Note:**  
You can print frames around arranged pages using the **Border** function.

**2** Check other settings, and then start printing.

## Manual Double-Sided Printing (Windows Only)

You can easily print on both sides of the paper by printing out all even numbered pages and then flipping those pages over and reloading them manually to print the odd numbered pages.

### Cautions when Performing Double-Sided Printing

When performing double-sided printing, note the following points.

- Always use paper suitable for double-sided printing.
- Depending on the paper type and the print data, ink may seep through to the back side of the paper.
- The double-sided printing function cannot be used when printing with roll paper.
- Performing successive double-sided print jobs from a paper cassette can cause a reduction in print quality or paper jams. If you notice a reduction in print quality, either lower the color density in the printer driver, or feed the paper manually one sheet at a time.
- Performing successive double-sided print jobs can soil the inside of the printer with ink. If the printed paper is soiled by ink on the roller, clean the printer.  
[“Cleaning the paper cassette printing path” on page 138](#)

**Note:**  
You can save even more paper by combining this printing method with printing multiple pages on a single page.

[“Multi-Page Printing” on page 82](#)

Printing Varieties

Setting Procedures for Printing

- 1 Load cut sheets.  
 ☞ “Loading Cut Sheets” on page 38
- 2 When the printer driver's **Page Layout** screen is displayed, select **Double-Sided Printing**.  
 When **Roll Paper** is selected as the **Source** setting, you cannot select **Double-Sided Printing**. In this case, set the **Source** first from the **Main**.

☞ “Printing (Windows)” on page 48

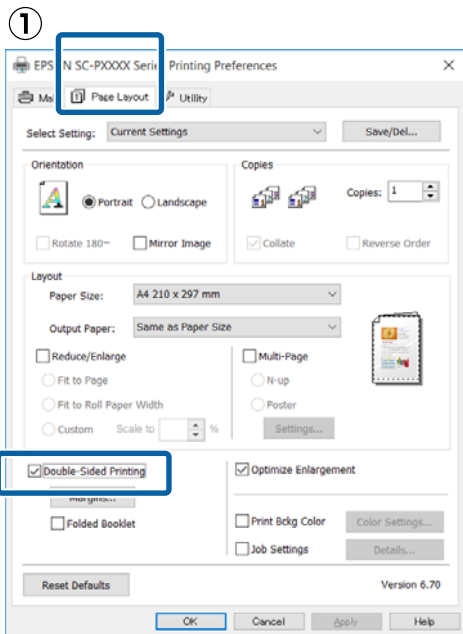

Note:

- ☐ You can set the **Binding Edge** and **Binding Margin** by clicking on **Margins**. Depending on the application, the specified binding margin and the actual print result may differ.

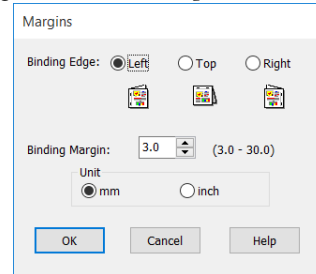

- ☐ Select **Folded Booklet** to print out as a booklet. In the example figure shown below, the pages that appear on the inside when the page is folded in two (pages 2, 3, 6, 7, 10, 11) are printed first.

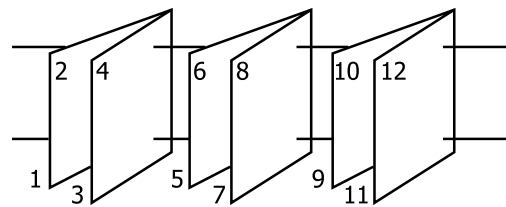

- 3 Check other settings, and then start printing.

- 4 When the odd pages have finished printing and the on-screen guide appears, reload the paper as instructed, and then click **Resume**.

Printing Varieties

# Poster Printing (Enlarge to cover several sheets and print - Windows only)

The poster printing function automatically enlarges and divides the print data. You can join the printed sheets to create a large poster or calendar. Poster printing is available up to 16-fold (four sheets by four sheets) of normal printing size. There are two ways to print posters.

- Borderless poster printing**  
This automatically enlarges and divides the print data and prints without margins. You can make a poster just by joining the output paper together. To perform borderless printing, the data is expanded so that it extends slightly over the paper size. Enlarged areas that exceed the paper are not printed. Therefore, the image may misalign at the joins. To join the pages precisely, perform the following poster printing with margins.

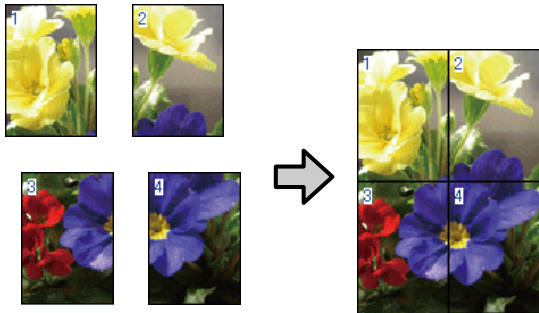

- Poster printing with margins**  
This automatically enlarges and divides the print data and prints with margins. You need to cut the margins and then join the output paper together to make a poster. Although the final size is slightly smaller since you have to cut off the margins, the image joins fit precisely.

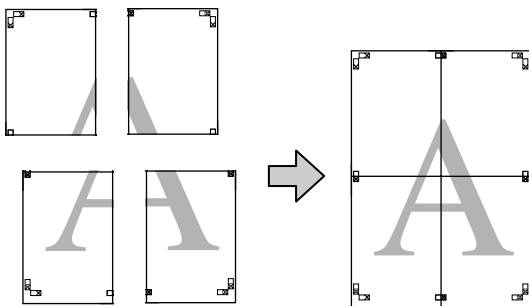

## Setting Procedures for Printing

- 1** Prepare the print data using applications.  
The printer driver automatically enlarges the image data when printing.
- 2** When the printer driver's **Page Layout** screen is displayed, select the **Multi-Page** check box, select **Poster**, and then click **Settings**.

☞ "Printing (Windows)" on page 48

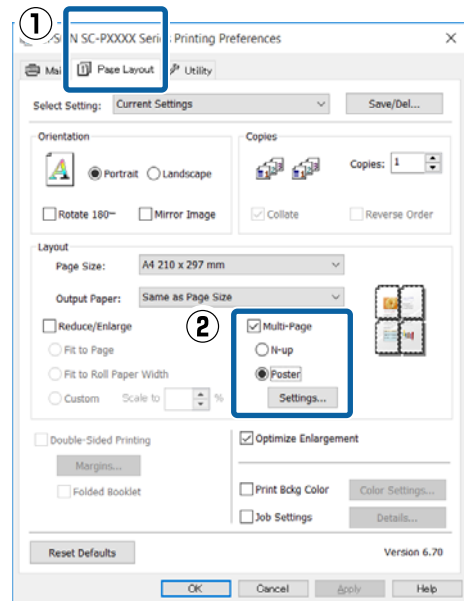

- 3** In the **Poster Settings** screen, select the number of sheets you want in the poster.

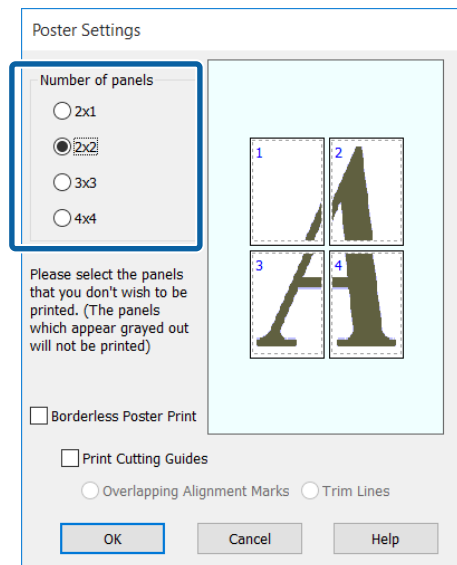

Printing Varieties

**4** Select borderless poster printing or poster printing with margins, and then select any pages that you do not want to print.

**When borderless is selected:**  
Select **Borderless Poster Print**.

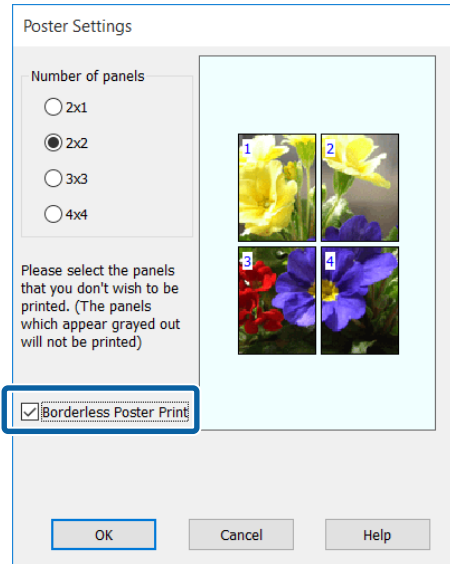

**Note:**  
If **Borderless Poster Print** is grayed out, the selected paper or the size does not support borderless printing.

[🔗 “Epson Special Media Table” on page 163](#)

[🔗 “Supported Commercially Available Paper” on page 173](#)

**When with margins is selected:**  
Clear **Borderless Poster Print**.

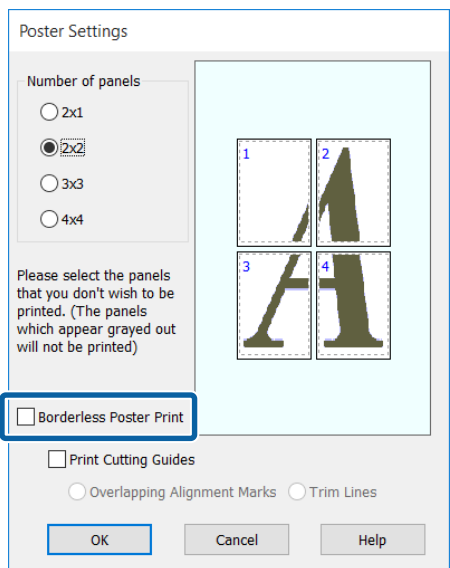

**Note:**  
Regarding the size after joining together:  
When **Borderless Poster Print** is cleared and printing with margins is selected, the **Print Cutting Guides** items are displayed.  
The finished size is the same whether or not **Trim Lines** is selected. However, if **Overlapping Alignment Marks** is selected, the finished size is smaller with an overlap.

**5** Check other settings, and then start printing.

Printing Varieties

## Joining the output paper together

The steps for joining the output paper together differ between borderless poster printing and poster printing with margins.

### Borderless poster printing

This section describes how to join four printed sheets together. Check and match the printed pages, and join them in the order indicated below using an adhesive tape on the back of the sheets.

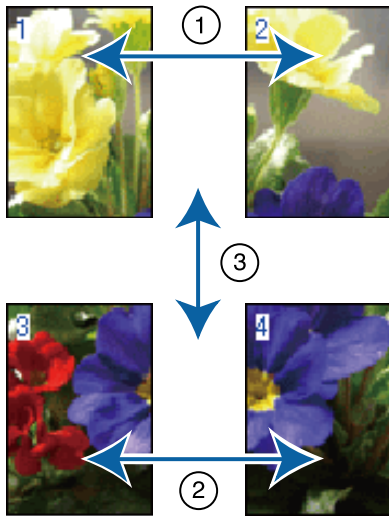

### Poster printing with margins

If **Overlapping Alignment Marks** is selected, join guides (indicated by the lines drawn through and around the X marks in the illustration below) will be printed on each sheet.

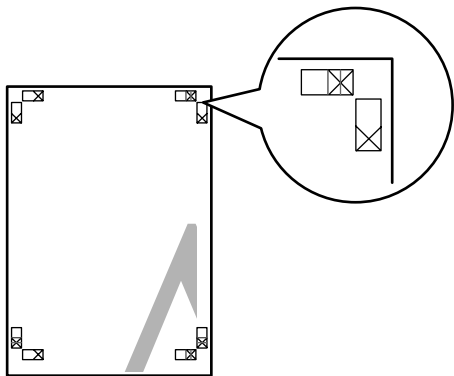

**Note:**  
The alignment marks are black for black-and-white printing.

The following section describes how to join four printed sheets together.

- 1 Ready the two top sheets and trim the excess from the left sheet by cutting along the line joining the two join guides (the centers of the X marks).

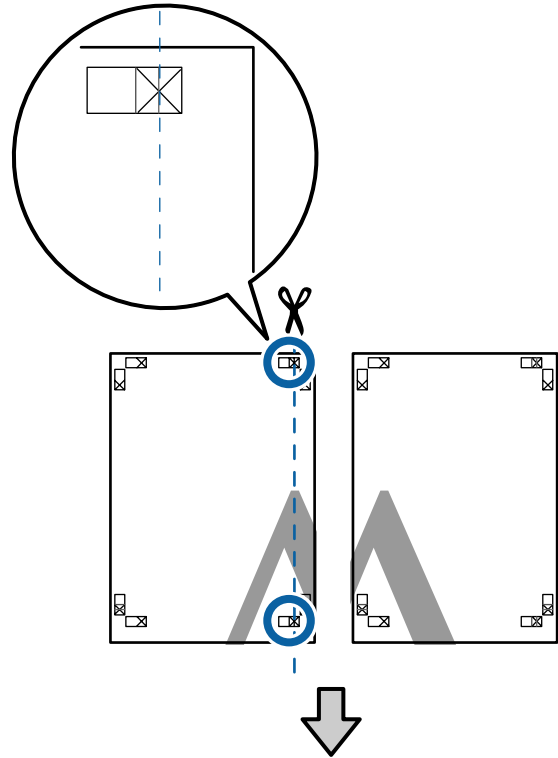

- 2 Lay the upper left sheet on top of upper right sheet. Lineup the X marks as shown in the illustration below, and temporarily fasten them using an adhesive tape on the back.

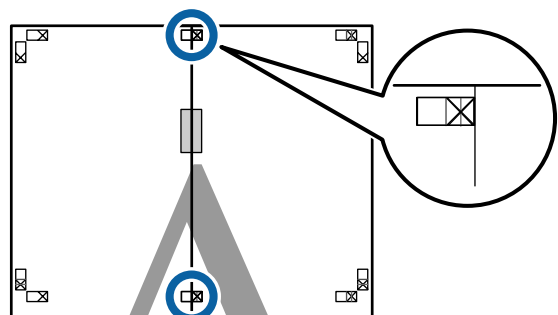

Printing Varieties

- 3** With the two sheets overlapping, trim the excess by cutting along the line joining the two cut guides (the lines to the left of the X marks).

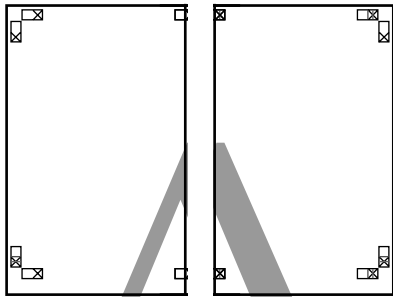
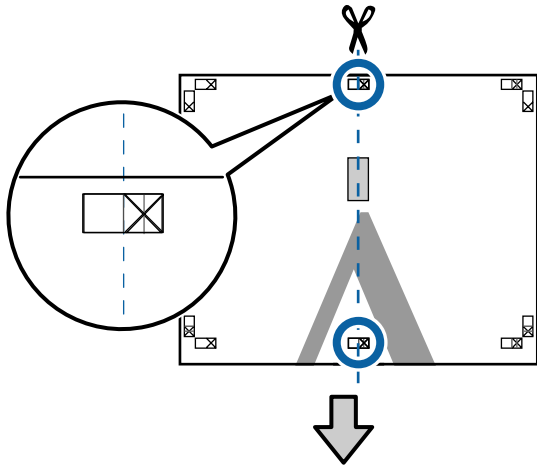

- 4** Rejoin the two sheets.  
Use an adhesive tape to stick the backs of the sheets together.

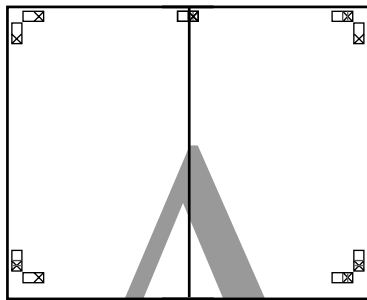

- 5** Repeat steps 1 to 4 for the two lower sheets.

- 6** Trim the bottom from the upper sheets by cutting along the line joining the two guides (the lines above the X marks).

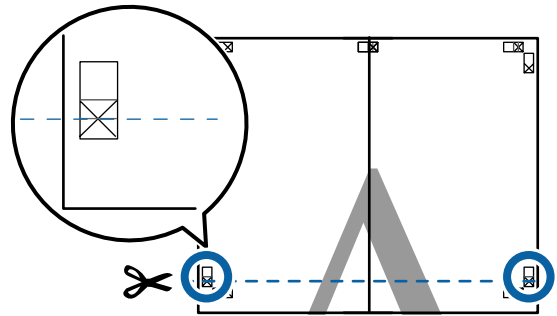

- 7** Lay the upper sheet on top of the lower sheet. Lineup the X marks as shown in the illustration below, and temporarily fasten them using an adhesive tape on the back.

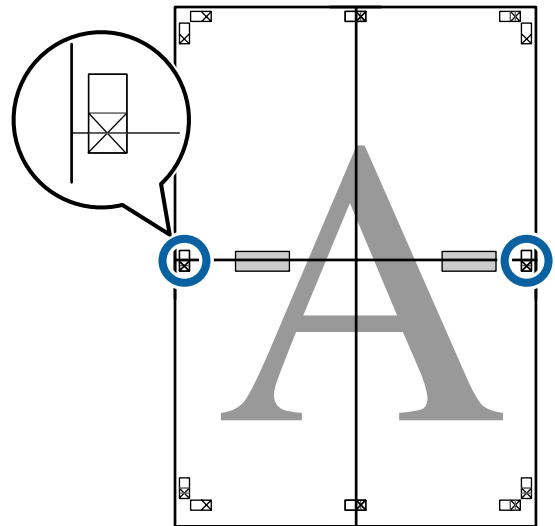



### Printing Varieties

- 8** With the two sheets overlapping, trim the excess by cutting along the line joining the two cut guides (the lines above the X marks).

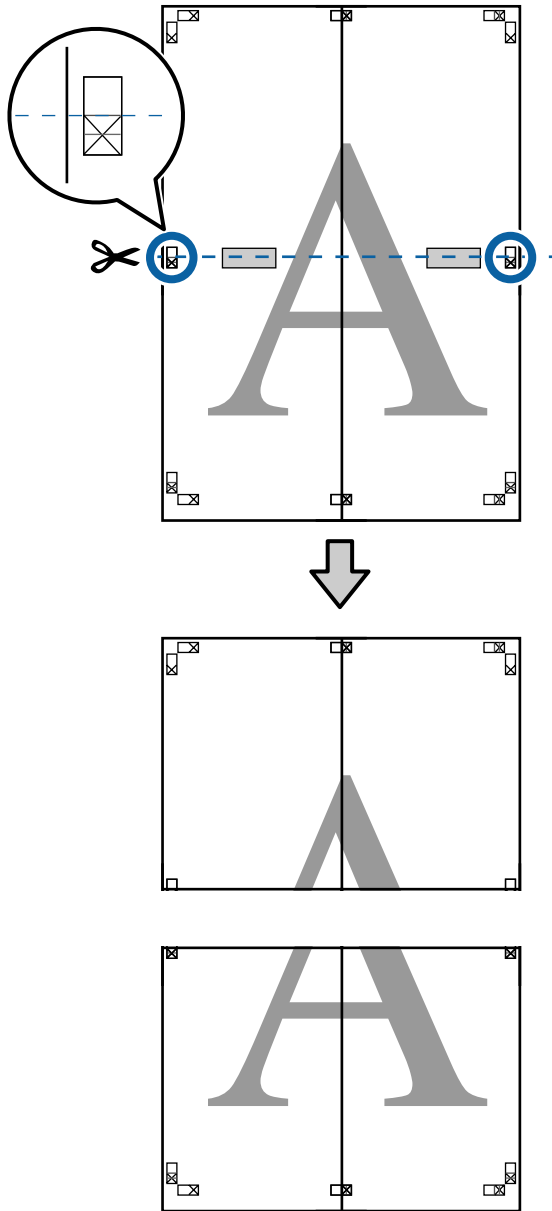

- 9** Join the upper and lower sheets together. Use an adhesive tape to stick the backs of the sheets together.

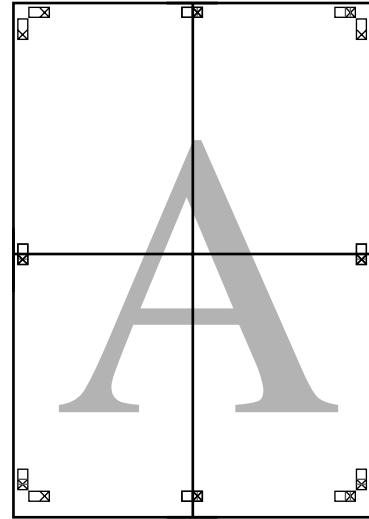

Printing Varieties

**10** After joining all the sheets, trim off the borders by cutting along the cut guides (outside the X marks).

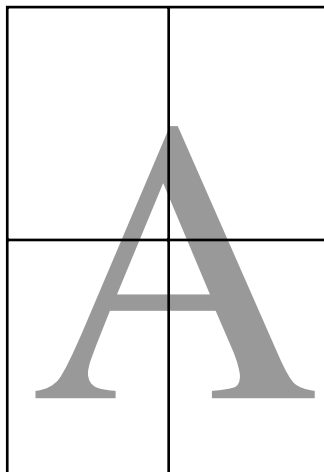
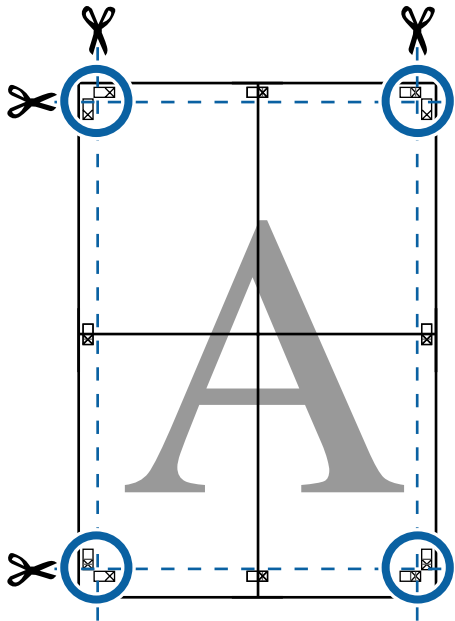

## Printing at Non-Standard Sizes

Before printing at non-standard sizes, including vertical or horizontal banners and documents with equal sides, save the desired paper size in the printer driver. Once they have been saved in the printer driver, custom sizes can be selected in the application **Page Setup** and other print dialogs.

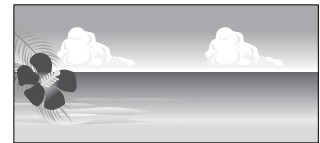

### Supported paper sizes

The following table shows the paper sizes that can be set in the printer driver. See the following for paper sizes supported by the printer.

[“Printable area” on page 52](#)

Paper Width	89 to 432 mm
Paper Height	Windows: 127* <sup>1</sup> to 15000 mm Mac OS X: 127* <sup>1</sup> to 15240 mm* <sup>2</sup>

- \*1 The smallest size supported by the printer is 203 mm wide by 254 mm long. If a smaller size is entered in the printer driver as a Custom Paper Size, the document will print with wider-than-expected margins, which must be trimmed.
- \*2 For Mac OS X **Custom Paper Sizes**, although you can specify a large paper size which cannot be loaded on this printer, it will not be printed properly.

**Important:**

*When using commercially available software, the possible output sizes are restricted. If you are using applications that support banner printing, you can set a longer paper length. See the application's manual for details.*

## Printing Varieties

### Making Settings in Windows

**1** When the printer driver's **Main** screen is displayed, click **User Defined**.

["Printing \(Windows\)" on page 48](#)

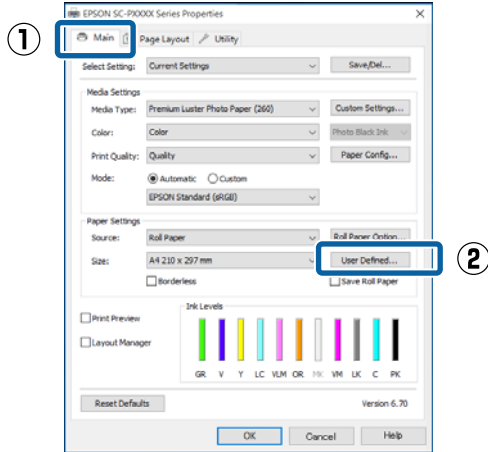

**2** In the **User Defined Paper Size** screen, set the paper size you want to use, and then click **Save**.

- You can enter up to 24 single-byte characters for the **Paper Size Name**.
- The length and width values for a pre-defined size close to the desired custom size can be displayed by selecting the appropriate option in the **Base Paper Size** menu.
- If the length and width ratio is the same as a defined paper size, select the defined paper size from **Fix Aspect Ratio** and select either **Landscape** or **Portrait** for the **Base**. In this case, you can only adjust either the paper width or paper height.

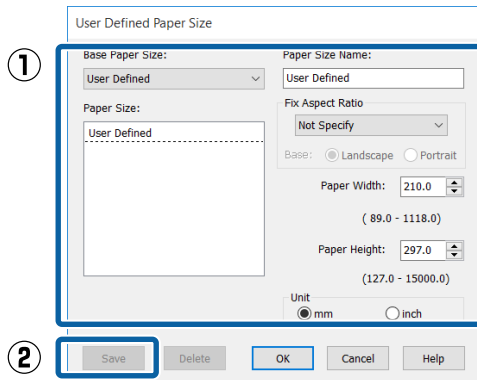

#### Note:

- To change the paper size you saved, select the paper size name from the list on the left.
- To delete the user-defined size you saved, select the paper size name from the list on the left, and then click **Delete**.
- You can save up to 100 paper sizes.

**3** Click **OK**.

You can now select the new paper size from the **Size** menu in the **Main** tab.

You can now print as normal.

### Making Settings for Mac OS X

**1** When the Print screen is displayed, select **Manage Custom Sizes** from the **Paper Size** list.

If page setting options are not available in the application's print dialog, display the page settings dialog.

["Printing \(Mac OS X\)" on page 49](#)

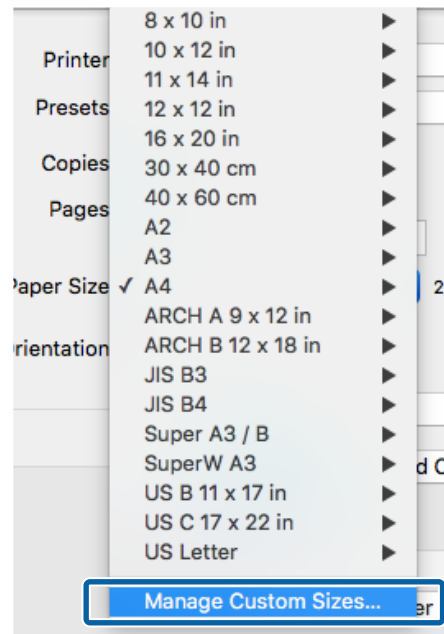

Printing Varieties

**2** Click +, and then enter the paper size name.

**3** Enter the **Width**, **Height** for the **Paper Size**, enter the margins, and then click **OK**.

You can set the page size and printer margins depending on the printing method.

**Note:**

- To edit a saved custom size, choose its name from the list on the left.
- To copy a saved custom size, select the size in the list on the left and click **Duplicate**.
- To delete a saved custom size, select it in the list on the left and click -.
- The custom paper size setting differs depending on the operating system version. See your operating system's documentation for details.

**4** Click **OK**.

You can select the paper size you saved from the Paper Size pop-up menu.

You can now print as normal.

## Banner printing (on roll paper)

You can print banners and panoramic pictures if you create and set print data for banner printing in your application.

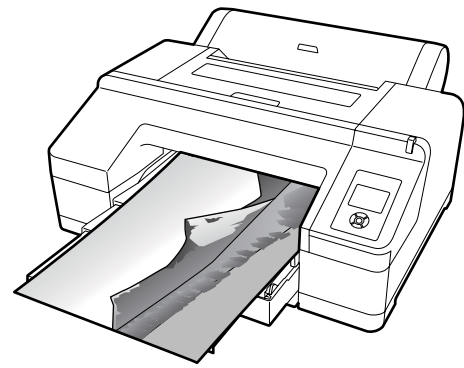

There are two ways to print a banner.

Printer Driver Source	Supported Applications
Roll Paper	Document preparation software, image editing software, and so on*1
Roll paper (Banner)*2	Applications that support banner printing

\*1 Create print data at a size supported by the given application while maintaining the printing length and width ratio.

\*2 Windows Only

See the following for available paper sizes.

["Printing at Non-Standard Sizes" on page 90](#)

## Printing Varieties

### Making Settings in Windows

**1** In the printer driver's **Main** screen, select **Media Type**.

"Printing (Windows)" on page 48

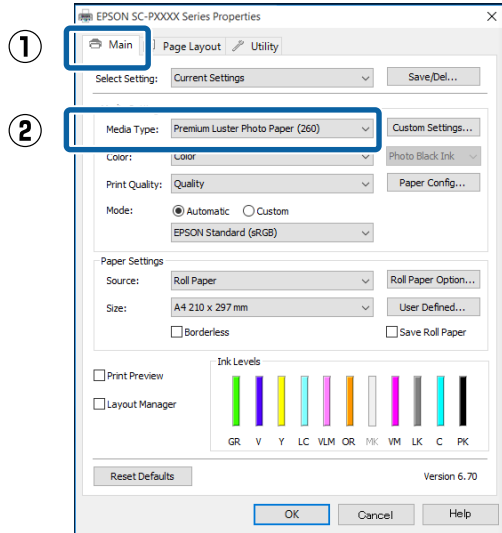

**2** Select **Roll Paper** or **Roll Paper (Banner)** from the **Source** list.

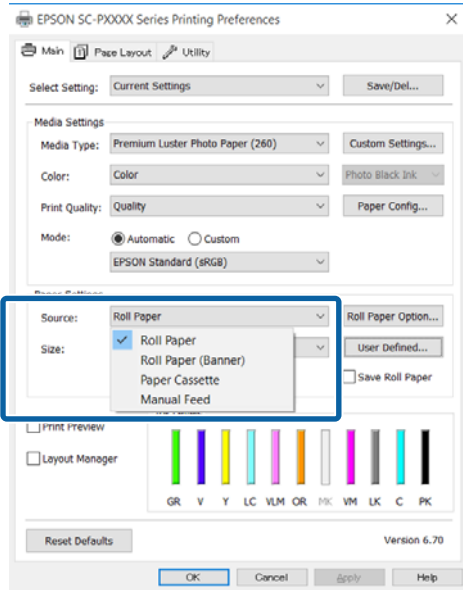

**Note:**

- You can only use **Roll Paper (Banner)** for applications that support banner printing.
- Selecting **Roll Paper (Banner)** sets the top and bottom margins of the paper to 0 mm.

**3** Click **User Defined** and match the paper size to the size of the data if necessary.

**Note:**

*If you are using applications that support banner printing, you do not need to set **User Defined Paper Size** if you select **Roll Paper (Banner)** as the **Source**.*

**4** On the **Page Layout** screen make sure the **Optimize Enlargement** check box is selected.

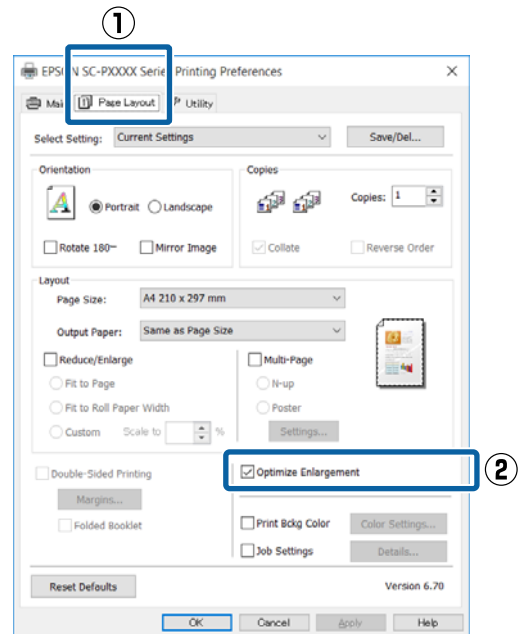

**5** Check other settings, and then start printing.

### Making Settings for Mac OS X

**1** When the **Print** screen is displayed, select the size of the data created with the application in **Paper Size**.

If page setting options are not available in the application's print dialog, display the page settings dialog.

Printing Varieties

“Printing (Mac OS X)” on page 49

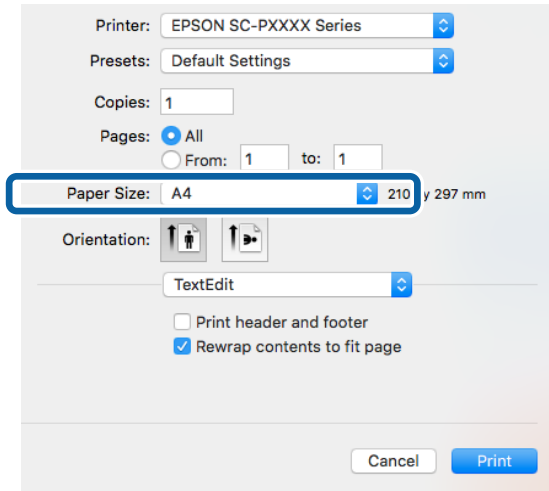

**2** Check other settings, and then start printing.

# Layout Manager (Windows Only)

The Layout Manager function allows you to place multiple pieces of print data created in different applications on the paper freely and print them at once.

You can create a poster or display material by placing multiple pieces of print data where you like. Also, Layout Manager allows you to use paper effectively.

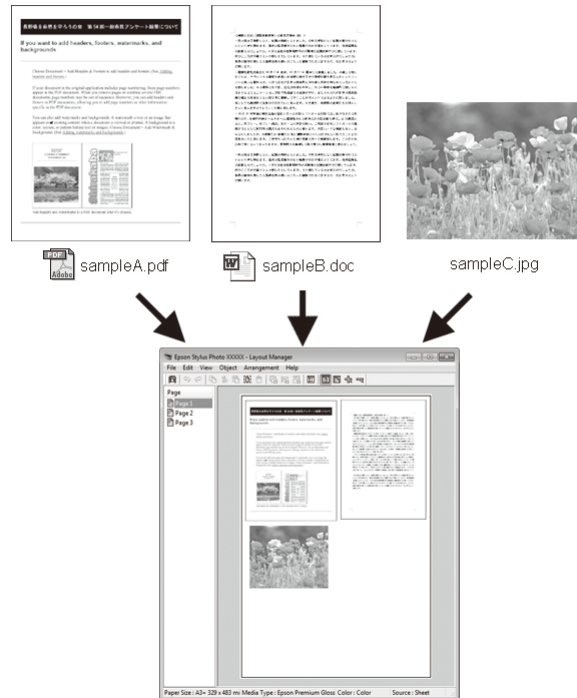

The following is a layout example.

### Placing multiple data items

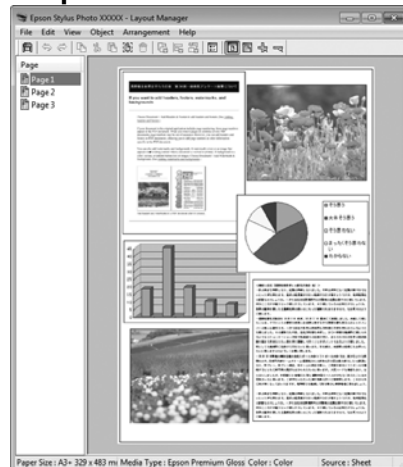

## Printing Varieties

### Placing the same data

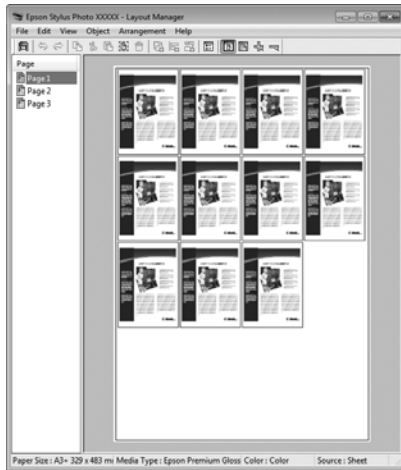

### Placing data freely

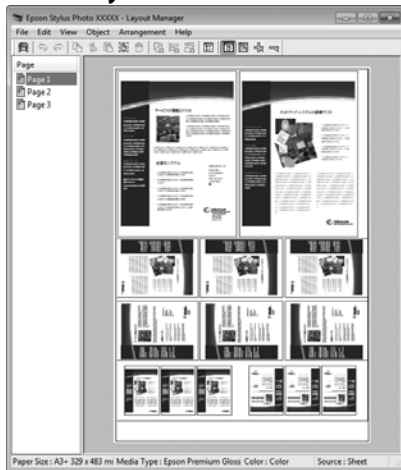

### Placing data on roll paper

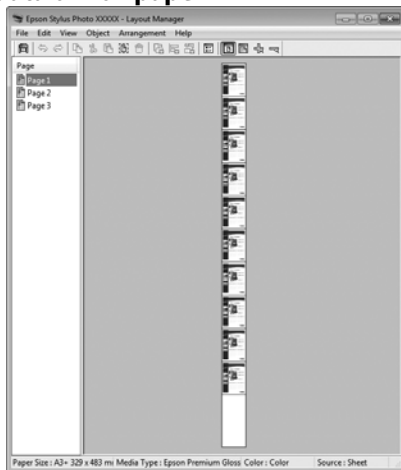

## Setting Procedures for Printing

**1** Check that the printer is connected and ready to print.

**2** Open the file you want to print in your application.

**3** Select **Layout Manager** in the **Main** tab of the printer driver and choose an option for **Size** that matches the size of the document created in the application.

“Printing (Windows)” on page 48



**Note:**

The option selected for **Size** is the size used in the **Layout Manager**. The actual printing paper size is set in the screen in step 7.

**4** Click **OK**. When printing with an application, the **Layout Manager** screen opens.

The print data is not printed, but one page is placed on the paper of the **Layout Manager** screen as one object.

**5** Leave the **Layout Manager** screen open and repeat steps 2 to 4 to arrange the next pieces of data.

The objects are added to the **Layout Manager** screen.

**6** Arrange the objects on the **Layout Manager** screen.

Objects can be dragged to new positions and resized; in addition, they can be rearranged or rotated using the options in the Object menu.

## Printing Varieties

The overall size and placement of the objects can be changed using the **Preferences** and **Arrangement** options in the File menu.

See the **Layout Manager** screen help for more details on each function.

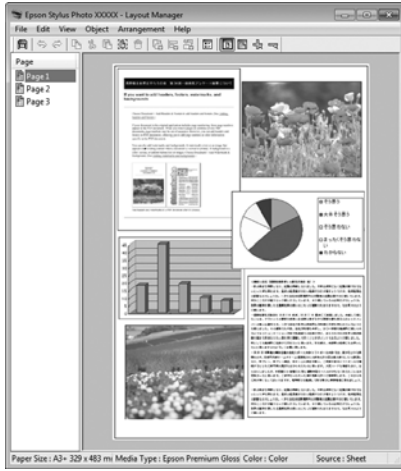

- 7 Click **File - Properties**, and make print settings on the printer driver screen.

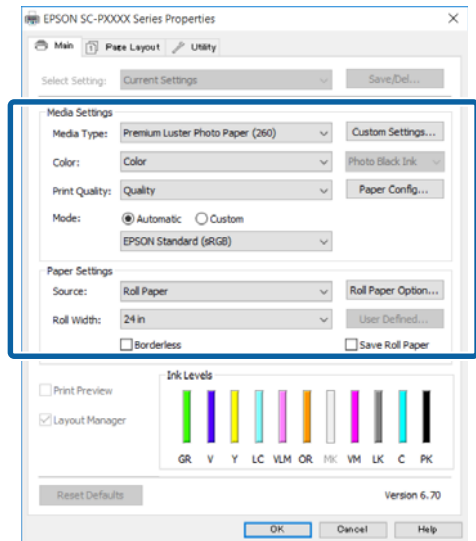
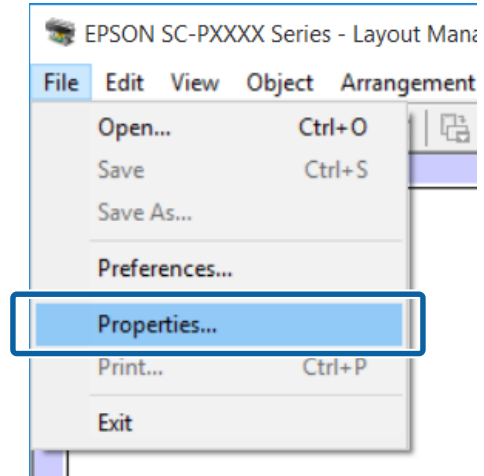

Set **Media Type, Source, Size or Roll Width**, and so on.

- 8 Click the **File** menu on the **Layout Manager** screen, and then click **Print**.

Printing starts.

## Saving and Recalling Settings

You can save the **Layout Manager** screen arrangement and setting contents to a file. If you need to close your application in the middle of a job, you can save it to a file and then open it later to continue your work.





## Printing Varieties

### Saving

- 1 On the **Layout Manager** screen, click **File** menu and then **Save As...**
- 2 Enter the file name, select the location, and then click **Save**.
- 3 Close the **Layout Manager** screen.

### Opening saved files

- 1 Right-click the utility icon () in the Windows taskbar and select **Layout Manager** from the menu that appears.  
  
The **Layout Manager** screen is displayed.  
  
If the Utility shortcut icon is not displayed on the Windows Taskbar  [“Summary of the Utility Tab” on page 61](#)
- 2 On the **Layout Manager** screen, click **File** menu and then **Open**.
- 3 Select the location and open the required file.

# Color Management Printing

## About Color Management

Even when using the same image data, the original image and the displayed image may look different, and the printed results may look different to the image you see on the display. This occurs due to the difference in characteristics when input devices such as scanners and digital cameras capture colors as electronic data, and when output devices such as display screens and printers reproduce colors from the color data. The color management system is a means to adjust differences in color conversion characteristics among input and output devices. As well as applications for image processing, each operating system is equipped with a color management system, such as ICM for Windows and ColorSync for Mac OS X.

In a color management system, a color definition file called a "Profile" is used to perform color matching between devices. (This file is also called an ICC profile.) The profile of an input device is called an input profile (or source profile), and the profile of an output device, such as a printer, is called a printer profile (or output profile). A profile is prepared for each media type in this printer's driver.

The color conversion areas by the input device and the color reproduction area by the output device differ. As a result, there are color areas that do not match even when performing color matching using a profile. In addition to specifying profiles, the color management system also specifies conversion conditions for areas where color matching failed as "intent". The name and type of intent vary depending on the color management system you are using.

You cannot match the colors on the printed results and display by color management between the input device and the printer. To match both colors, you need to perform color management between the input device and the display as well.

## Color Management Print Settings

You can perform color management printing using this printer's printer driver in the following two ways.

Choose the best method according to the application you are using, the operating system environment, the aim of the print out, and so on.



### Setting color management with the applications

This method is for printing from applications that support color management. All color management processes are carried out by the application's color management system. This method is useful when you want to obtain the same color management print results using a common application among different operating system environments.

 ["Setting color management with the applications" on page 99](#)

### Setting color management with the printer driver

The printer driver uses the operating system's color management system and carries out all color management processes. You can make color management settings in the printer driver using the following two methods.

- Host ICM (Windows) / ColorSync (Mac OS X)  
Set when printing from applications that support color management. This is effective in producing similar print results from different applications under the same operating systems.  
 ["Color management printing by Host ICM \(Windows\)" on page 101](#)  
 ["Color management printing by ColorSync \(Mac OS X\)" on page 102](#)
- Driver ICM (Windows only)  
This allows you to perform color management printing from applications that do not support color management.  
 ["Color management printing by Driver ICM\(Windows Only\)" on page 102](#)

Color Management Printing

## Setting profiles

Settings for the input profile, printer profile, and intent (matching method) vary between three types of color management printing since their color management engines are used differently. This is because color management usage differs between the engines. Make settings in the printer driver or application as described in the following table.

	Input profile settings	Printer profile settings	Intent settings
Driver ICM (Windows)	Printer Driver	Printer Driver	Printer Driver
Host ICM (Windows)	Application	Printer Driver	Printer Driver
ColorSync (Mac OS X)	Application	Printer Driver	Application
Application	Application	Application	Application

Printer profiles for each paper type that is needed when performing color management are installed with the printer's printer driver. You can select the profile from the printer driver's settings screen.

You can select the profile from the printer driver's settings screen.

[“Color management printing by Driver ICM\(Windows Only\)” on page 102](#)

[“Color management printing by Host ICM \(Windows\)” on page 101](#)

[“Color management printing by ColorSync \(Mac OS X\)” on page 102](#)

[“Setting color management with the applications” on page 99](#)

## Setting color management with the applications

Print using applications with a color management function. Make the color management settings in the application and disable the printer driver's color adjustment function.

**1** Make color management settings in the applications.

Setting example for Adobe Photoshop CS5

Open the **Print** screen.

Select **Color Management** and then **Document**. Select **Photoshop Manages Colors** as the **Color Handling** setting, select the **Printer Profile** and the **Rendering Intent**, and then click **Print**.

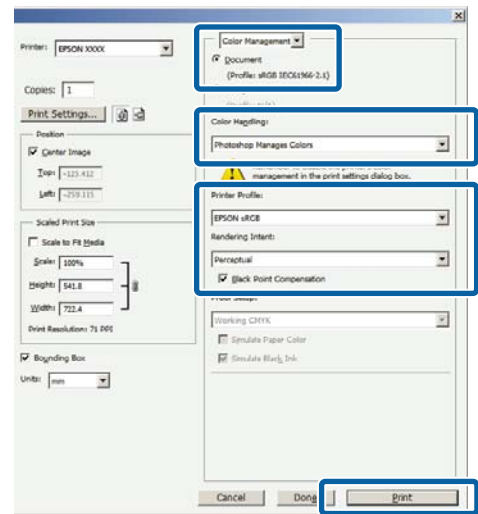

**2** Display the printer driver's settings screen (Windows) or Print screen (Mac OS X).

Make printer driver settings.

**For Windows**

[“Printing \(Windows\)” on page 48](#)

**For Mac OS X**

[“Printing \(Mac OS X\)” on page 49](#)

### Color Management Printing

**3** Set color management to off.

**For Windows**

In the **Main** screen, select **Custom** as the **Mode** setting, and select **Off (No Color Adjustment)**.

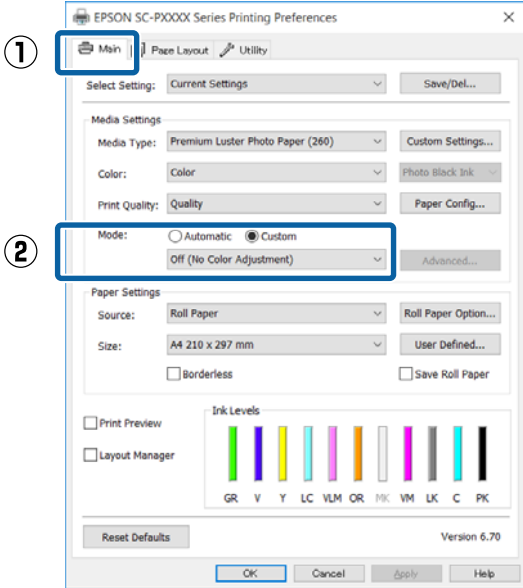

**Note:**

*In Windows 7, Windows Vista, and Windows XP (Service Pack 2 or later and .NET 3.0) Off (No Color Adjustment) is selected automatically.*

**For Mac OS X**

Select **Print Settings** from the list, and then select **Off (No Color Adjustment)** as the **Printer Color Adjustment** setting.

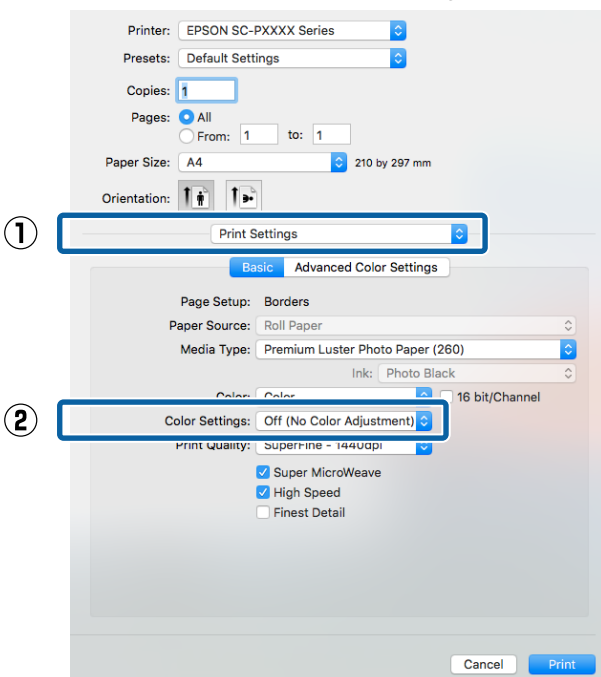

**4** Check other settings, and then start printing.

**Color Management Printing**

# Setting color management with the printer driver

## Color management printing by Host ICM (Windows)

Use image data in which an input profile has been embedded. Also, the application must support ICM.

**1** Make the settings for color adjustment using the application.

Depending on the type of the application, make the settings following the table below.

Adobe Photoshop CS3 or later  
 Adobe Photoshop Elements 6.0 or later  
 Adobe Photoshop Lightroom 1 or later

OS	Color Management Settings
Windows 10, Windows 8.1, Windows 8, Windows 7, Windows Vista	Printer Manages Colors
Windows XP (Service Pack 2 or later and .NET 3.0 or later)	Printer Manages Colors
Windows XP (other than the above)	No Color Management

In other applications, set **No Color Management**.

**Note:**  
 For information on supported platforms, see the website for the application in question.

Setting example for Adobe Photoshop CS5

Open the **Print** screen.

Select **Color Management** and then **Document**. Select **Printer Manages Colors** as the **Color Handling** setting, and then click **Print**.

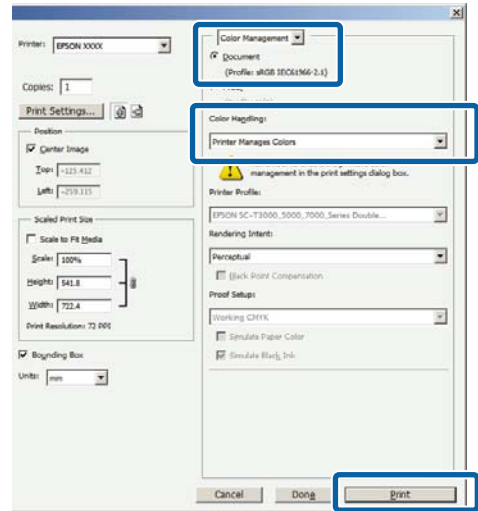

When using applications without a color management function, start from step 2.

**2** In the printer driver's **Main** screen, select **Custom** as the **Mode**, select **ICM**, and then click **Advanced**.

☞ [“Printing \(Windows\)” on page 48](#)

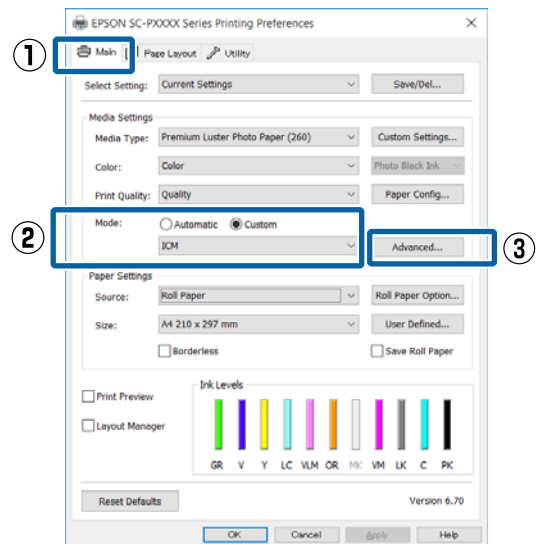

**3** Select **ICM Mode** in Printer Color Adjustment. See the printer driver help for more details.

## Color Management Printing

When Epson special media is selected for **Media Type** in the **Main** screen, the printer profile corresponding to the media type is automatically selected and displayed in the **Printer Profile Description** box.

To change the profile, select **Show all profiles** at the bottom.

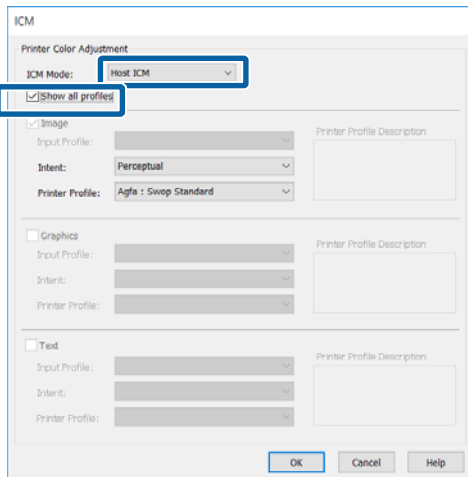

- 4 Check other settings, and then start printing.

### Color management printing by ColorSync (Mac OS X)

Use image data in which an input profile has been embedded. Also, the application must support ColorSync.

**Note:**  
Depending on the application, color management printing by **ColorSync** may not be supported.

- 1 Disable the color management functions in the application.
- 2 Display the Print screen.  
🔗 ["Printing \(Mac OS X\)" on page 49](#)

- 3 Select **Color Matching** from the list, and then click **ColorSync**.

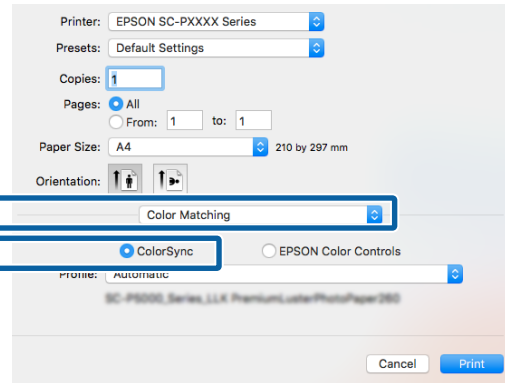

- 4 Check other settings, and then start printing.

### Color management printing by Driver ICM (Windows Only)

The printer driver uses its own printer profiles to perform color management. You can use the following two color correction methods.

- Driver ICM (Basic)  
Specify one type of profile and intent for processing the entire image data.
- Driver ICM (Advanced)  
The printer driver distinguishes the image data into the **Image**, **Graphics**, and **Text** areas. Specify three types of profiles and intents for processing each area.

#### When using applications featuring a color management function

Make the settings for color processing using the application before making printer driver settings.

Depending on the type of the application, make the settings following the table below.

Adobe Photoshop CS3 or later  
 Adobe Photoshop Elements 6.0 or later  
 Adobe Photoshop Lightroom 1 or later

### Color Management Printing

OS	Color Management Settings
Windows 10, Windows 8.1, Windows 8, Windows 7, Windows Vista	Printer Manages Colors
Windows XP (Service Pack 2 or later and .NET 3.0 or later)	
Windows XP (other than the above)	No Color Management

In other applications, set **No Color Management**.

**Note:**  
For information on supported platforms, see the website for the application in question.

Setting example for Adobe Photoshop CS5

Open the **Print** screen.

Select **Color Management** and then **Document**.  
Select **Printer Manages Colors** as the **Color Handling** setting, and then click **Print**.

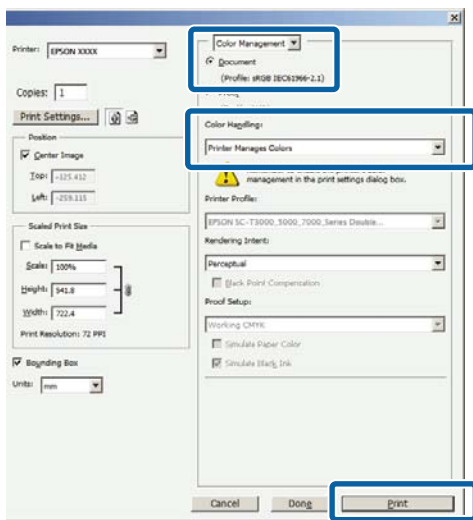

**1** In the printer driver's **Main** screen, select **Custom** as the **Mode**, select **ICM**, and then click **Advanced**.

“Printing (Windows)” on page 48

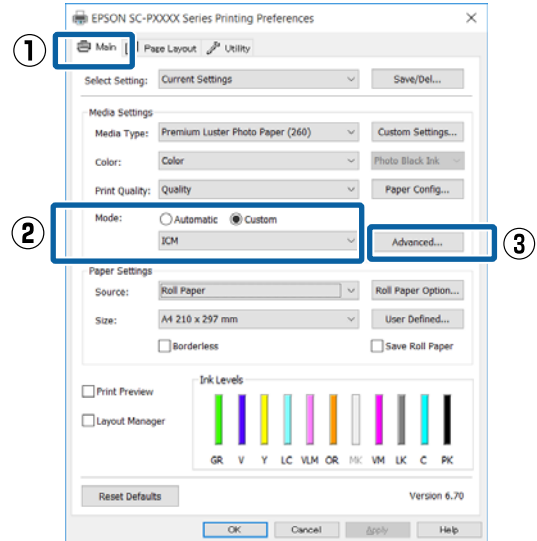

**2** From **ICM Mode** in the **ICM** screen, select **Driver ICM (Basic)** or **Driver ICM (Advanced)**.

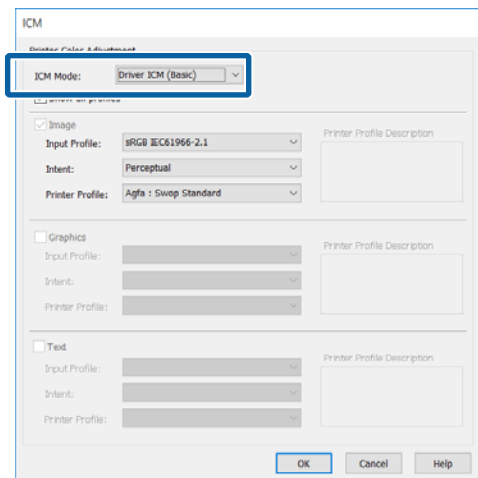

If you select **Driver ICM (Advanced)**, you can specify the profiles and intent for each image such as photos, graphics, and text data.

Intent	Explanation
Saturation	Keeps the current saturation unchanged and converts the data.
Perceptual	Converts the data so that a more visually natural image is produced. This feature is used when a wider gamut of color is used for image data.

## Color Management Printing

Intent	Explanation
Relative Colorimetric	Converts the data so that a set of color gamut and white point (or color temperature) coordinates in the original data match their corresponding print coordinates. This feature is used for many types of color matching.
Absolute Colorimetric	Assigns absolute color gamut coordinates to the original and print data and converts the data. Therefore, color tone adjustment is not performed on any white point (or color temperature) for the original or print data. This feature is used for special purposes such as logo color printing.

**3**

Check other settings, and then start printing.



# Using the Control Panel Menu

## Menu Operations

Operate the menus as shown below. The explanations use **Platen Gap** in the **Printer Setup** as an example.

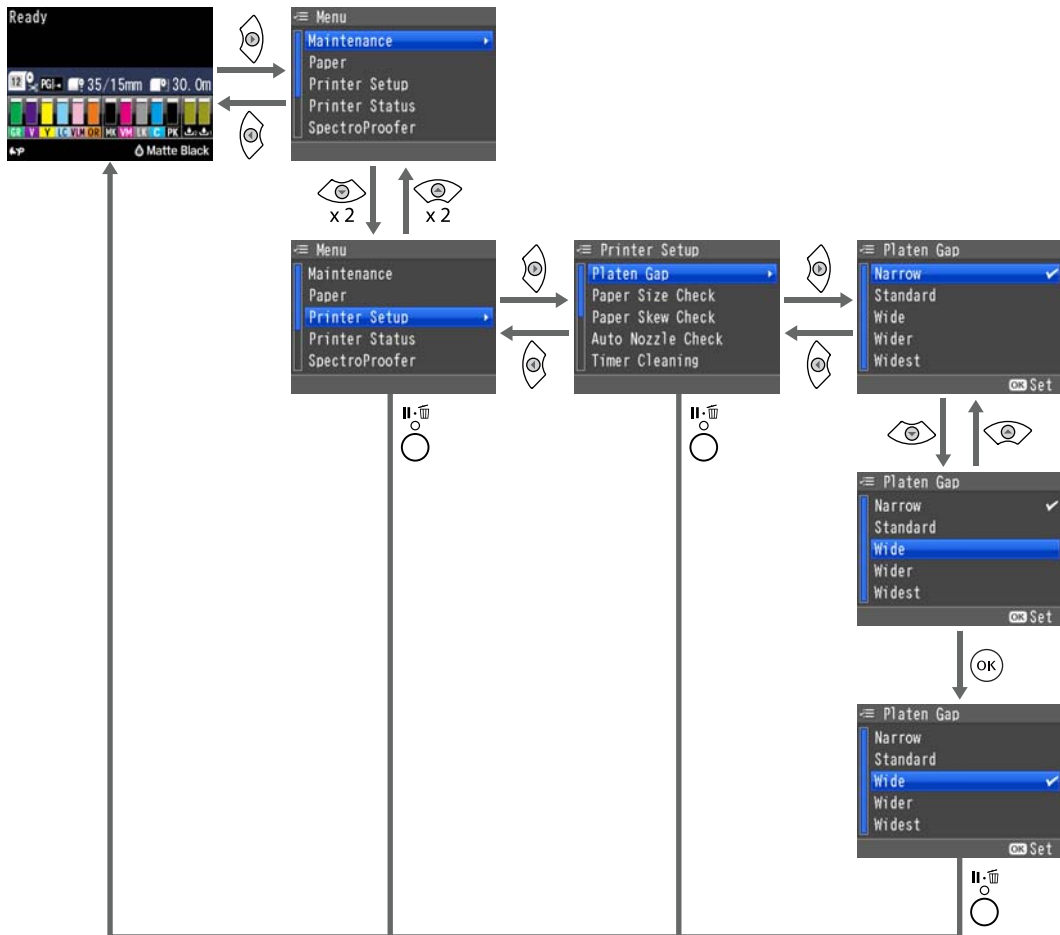

**Note:**

If the  $\text{Back}/\text{A}$  button is pressed in the ready status, the **Maintenance** Menu is displayed on the screen.

If the  $\text{Back}/\text{A}$  button is pressed while printing is temporarily stopped (paused), you can only perform a nozzle check or head cleaning.

## Using the Control Panel Menu

## Menu List

The items and options available in the menu are described below. See the reference pages for more details on each item.

---

### Maintenance menu

 [“Maintenance” on page 111](#)

Menu item		Description		
Nozzle Check	Printless Nozzle Check		Press OK to start checking.	
	Print Check Pattern		Press OK to start printing.	
Head Cleaning	Check And Clean Nozzle		Press OK to start cleaning.	
	All Nozzles	Normal, Heavy		
	Select Nozzles	C/VM, PK(MK)/LK, OR/GR, LGY(LLK)/Y, VLM/LC		Normal, Heavy
Head Alignment	Paper Thickness	Paper Type		Lists supported Epson media.
		Paper Thickness		0.1 to 1.5 mm
	Alignment	Auto	Uni-D, Bi-D 5-Color, Bi-D All	Press OK to start printing/alignment.
		Manual	Uni-D, Bi-D 2-color, Bi-D All	Press OK to start printing.
Adjust Cut Position			-3 to 3 mm	
Change Black Ink			Press OK to start switching black ink.	

---

### Paper menu

 [“Paper” on page 113](#)

**Using the Control Panel Menu**

Menu item			Description	
Paper Type			Photo Paper	Lists supported Epson media.
			Proofing Paper	
			Fine Art Paper	
			Matte Paper	
			Plain Paper	
			Others	
			Custom Paper	
			No Paper Selected	—
Custom Paper	Paper No. (XX)	Select Reference Paper	Photo Paper	Lists supported Epson media.
			Proofing Paper	
			Fine Art Paper	
			Matte Paper	
			Plain Paper	
			Others	
		Platen Gap		Standard, Wide, Wider
	Thickness Pattern		Press OK to start printing.	
	Paper Feed Adjust A	Pattern	Press OK to start printing.	
		Value	-0.70 to +0.70%	
	Paper Feed Adjust B		-0.70 to +0.70%	
	Drying Time		0.0 to 10.0 sec	
	Paper Suction		-4 to -1, Standard	
	Set Roll Paper Tension		Nomal, High, Extra High	
Remove Skew		On, Off		
Print Paper List			Press OK to start printing.	
Roll Paper Remaining			Remaining Paper Setup	On, Off
			Roll Paper Length	5.0 to 99.5 m
			Roll Length Alert	1 to 15 m
Cut Sheet Remaining			Sheet Number	10 to 990 sheets
			Sheet Number Alert	1 to 50 sheets

## Using the Control Panel Menu

Menu item		Description
Roll Paper Setup	Print Page Line	On, Off
	Roll Paper Margin	Standard, Top 15 mm/Bottom 15 mm, Top 35 mm/Bottom 15 mm, 3 mm, 15 mm
	Auto Roll Feeding	On, Off
Refresh Margin		On, Off

## Printer Setup Menu

 [“Printer Setup” on page 117](#)

Menu item		Description
Platen Gap		Narrow, Standard, Wide, Wider, Widest
Paper Size Check		On, Off
Paper Skew Check		On, Off
Auto Nozzle Check	Auto Cleaning Setting	On:Periodically, On:Every Job, Off
	Auto Cleaning Times	1 to 3
Timer Cleaning		6 to 60 hours, Off
Print Nozzle Pattern		Every 10 pages, Every Page, Off
Auto Black Ink Change		Manual, Auto
BK Ink Change Setting		Normal, Quick
Calibration Setting		On, Off
Initialize Settings		Reset with the OK button

## Printer Status Menu

 [“Printer Status” on page 118](#)

Menu item	Description
Firmware Version	xxxxxxx,xx.xx,xxxx
Print Status Sheet	Press OK to start printing.
Calibration Date	MM/DD/YY HH:MM
Total Prints	xxxxxx pages
Print Job Information	Press OK to start printing.

## Using the Control Panel Menu

### SpectroProofer Menu

The following menus are only displayed when the optional SpectroProofer mounter is installed.

 [“SpectroProofer” on page 119](#)

Menu item		Description
SProofer Status	Device Version:ILS	xxxxxx
	Calibration Tile S/N	xxxxxx
	Firmware Version	xxxxxx
	Device Temperature	XX°C
	Air Temperature	XX°C
	Backing Color	Displays the installed backing colors.
	Calibration Status	Shows either <b>Successful</b> or <b>Failed</b>

### Network Setup Menu

 [“Network Setup” on page 119](#)

Items indicated by \*1 are displayed when **Show** is selected in the **Network Settings**.

Items indicated by \*2 are displayed when **Panel** is selected in the **IP Address Setting**.

Menu item	Description
Network Settings	Hide, Show
IP Address Setting *1	Auto, Panel
IP, SM, DG Setting *2	IP Address, Subnet Mask, Default Gateway
Print Status Sheet *1	Press OK to start printing.
Init Network Setting *1	Reset with the OK button

### Preferences Menu

 [“Preferences” on page 120](#)

Menu item	Description
Language	Lists the supported languages.
Length Units	Metric, Feet/Inch
Temperature Units	°C, °F

## Using the Control Panel Menu

Menu item		Description
Maintenance Alert		Disable, Ink, Maintenance Box, Ink Or Maint Box, Paper, All
Cut Sheet Remaining		Off, On
Sleep Mode		5 minutes, 15 minutes, 60 minutes, 120 minutes , 210 minutes
Power Management	Power Off Timer	Disable, Enable
	Time To Off	After 1 to 24 hours

---

## Administrator Menu

 [“Administrator Menu” on page 121](#)

Menu item		Description
Powerful Cleaning	All Nozzles, C/VM, PK(MK)/LY, OR/GR, LGY(LLK)/Y, VLM/LC	Press OK to start cleaning.
Clock Setting		MM/DD/YY HH:MM
Reset All Settings		Reset with the OK button

Using the Control Panel Menu

# Menu Descriptions

## Maintenance

Item		Description		
Nozzle Check	Printless Nozzle Check		When you press the OK button, you can check the status of the nozzles, and the results of clogging detection are displayed on the control panel. When clogged nozzles are detected, if you press the  button, then cleaning starts automatically.	
	Print Check Pattern		Press the OK button to print a nozzle check pattern. Inspect the pattern visually and perform head cleaning if you detect faint or missing colors. <a href="#">☞ "Checking for clogged nozzles" on page 123</a>	
Head Cleaning	Check And Clean Nozzle		When you press the OK button, you can check the status of the nozzles and automatically clean only the nozzle arrays that are clogged.	
	All Nozzles	Normal, Heavy		
	Select Nozzles	C/VM, PK(MK)/LY, OR/GR, LGY(LLK)/Y, VLM/LC	Normal, Heavy	
			Select both the ink colors for head cleaning and the strength of the cleaning. Only use this menu when nozzles are clogged. <a href="#">☞ "Cleaning the print head" on page 123</a> <b>Ink colors to be cleaned</b> Check the ink colors with faint or missing segments in the check pattern, and then specify which nozzles to clean. The displayed items differ depending on the ink sets. <input type="checkbox"/> If there are faint or missing segments in all colors: Select <b>All Nozzles</b> . <input type="checkbox"/> If there are faint or missing segments in only a few colors: Select <b>Select Nozzles</b> , and then select the specific ink colors you want to clean. <b>Cleaning strength</b> Normally, select <b>Normal</b> . If nozzles are clogged even after performing <b>Normal</b> head cleaning several times, perform <b>Heavy</b> cleaning.	
Head Alignment	Paper Thickness	Paper Type		Perform print head alignment when the print results look grainy or out-of-focus. First, do <b>Paper Thickness</b> , and then do <b>Alignment</b> . <a href="#">☞ "Adjusting print misalignments (Head Alignment)" on page 126</a>
		Paper Thickness		
	Alignment	Auto	Uni-D, Bi-D 5-Color, Bi-D All	
		Manual	Uni-D, Bi-D 2-color, Bi-D All	
Adjust Cut Position	-3 to 3 mm		You can fine tune the cut position when printing to roll paper with no margins in all directions. The cut position can be adjusted in increments of 0.2 mm.	

### Using the Control Panel Menu

Item	Description
Change Black Ink	You can switch the type of black ink you want to use.  <a href="#">"Changing the Type of Black Ink" on page 53</a>



## Using the Control Panel Menu

## Paper

\* Default setting

Item		Description	
Paper Type	Photo Paper	Select the type of paper loaded. When loading commercially available paper, or when using customized paper settings, select the <b>Custom Paper</b> settings name.	
	Proofing Paper		
	Fine Art Paper		
	Matte Paper		
	Plain Paper		
	Others		
	Custom Paper		
	No Paper Selected		
Custom Paper	Paper Number	<p>Register paper information when using commercially available paper or when using customized paper settings for genuine Epson paper.</p> <p>You can register up to 10 by assigning them to Paper No. 1 to Paper No. 10. After registering, you can print using the saved settings simply by specifying the Paper No. Even when the printer is turned off, the saved settings are retained.</p> <p>See the following table for details on the setting content.</p> <p> <a href="#">"Custom Paper" on page 115</a></p>	
Print Paper List		Press the OK button to print a list of custom paper settings.	
Roll Paper Remaining	Remaining Paper Setup	On	<p>Select whether to display/record (<b>On</b>) or not to display/record (<b>Off</b>) the amount of remaining roll paper. If <b>On</b> is selected, you will be prompted to enter the length of the roll.</p> <p>When a length has been entered for the loaded roll paper, a barcode will automatically be printed on the roll stating the length remaining, the value selected for the roll remaining alert, and the paper type when the roll is removed.</p> <p>The barcode is automatically read and settings adjusted the next time the paper is used, improving efficiency when multiple rolls of paper are used.</p>
		Off*	
	Roll Paper Length	5.0 to 99.5 m	
Roll Length Alert	1 to 15 m (5*)	<p>Displayed when <b>On</b> is selected for <b>Remaining Paper Setup</b>.</p> <p>Set within a range from 1 to 15 m to display a warning when the amount of remaining roll paper drops below that limit. You can set in 1 m increments.</p>	

## Using the Control Panel Menu

Item			Description
Cut Sheet Remaining	Sheet Number	10 to 990 sheets	Set the number of sheets loaded in the paper cassette in a range from 10 to 990 sheets in increments of 10 sheets. The number of cut sheets remaining is displayed on the control panel's screen based on the settings you choose for <b>Sheet Number</b> and <b>Sheet Number Alert</b> .
	Sheet Number Alert	1 to 50 sheets	You can set the number of sheets left in the paper cassette at which a warning is displayed by entering a number between 1 and 50 sheets in increments of 1 sheet. The number of cut sheets remaining is displayed on the control panel's screen based on the settings you choose for <b>Sheet Number</b> and <b>Sheet Number Alert</b> .
Roll Paper Setup	Print Page Line	On*	Select whether to print ( <b>On</b> ) or not to print ( <b>Off</b> ) a page line (line along which to cut) on the roll paper. This is not printed on cut sheets. However, a vertical line is printed when the roll paper width that is specified on the computer is smaller than the width of the roll paper that is loaded in the printer. The setting selected with the printer driver takes priority when the printer driver is used.
		Off	
	Roll Paper Margin	Standard	When set to <b>Standard</b> , the top and bottom margins are 15 mm, and the left and right margins are 3 mm. Except for <b>15mm</b> , the left and right margins for all other settings are 3 mm.
		Top 15 mm/ Bottom 15 mm	
		Top 35 mm/ Bottom 15 mm	 <a href="#">"Printable area" on page 52</a>
		3 mm	
		15 mm	
Auto Roll Feeding	On*	When using the Epson special media UltraSmooth Fine Art Paper you must set this to Off before loading the paper. If set to On for UltraSmooth Fine Art Paper, the roller of the pressure roller may leave a mark on the surface of the paper. When using paper other than UltraSmooth Fine Art Paper, set it to On.	
	Off	When this is set to <b>On</b> , the following operations are available. When <b>Off</b> is selected, an error occurs and the following operations cannot be performed. <input type="checkbox"/> When a paper cassette is specified for printing from the printer driver and a print job is executed, roll paper is automatically set to saved mode and printing is performed by feeding from the paper cassette, even if roll paper is being fed to the printer. <input type="checkbox"/> Roll paper is automatically set to saved mode and cut paper can be fed when <b>Cut Sheet</b> is also selected from the <b>Paper Type</b> menu. After printing the cut sheets, and <b>Roll Paper/Cut</b> or <b>Roll Paper/No Cut</b> is selected from the <b>Paper Type</b> menu, roll paper is automatically fed from saved mode.	

### Using the Control Panel Menu

Item		Description
Refresh Margin	On*	This setting is effective for roll paper only.
	Off	After printing borderless on all edges, select whether to cut automatically ( <b>On</b> ) or not to cut ( <b>Off</b> ) the leading edge of the paper to remove any marks which may have been left in preparation for the next job when printing with margins.

## Custom Paper

Set all items in the following table for commercially available paper based on the characteristics of the paper. When customizing paper settings for genuine Epson paper, select the corresponding paper type from **Select Reference Paper**, and then enter your settings.

\* Default setting

Item		Description
Select Reference Paper	Photo Paper, Proofing Paper, Fine Art Paper, Matte Paper, Plain Paper, Others	You can select the media type that is the closest to the paper you are using.
Platen Gap	Standard*	Select the Platen Gap, which is the distance between the print head and the paper. Normally, select <b>Standard</b> . Select a wider setting if print results are scratched or smudged.
	Wide	
	Wider	
Thickness Pattern		<p>Press the OK button to print a pattern to determine the thickness of the current paper. Select the pattern number with the least misalignment from the print results.</p> <p>In the following example image, "4" is the best choice.</p> 

### Using the Control Panel Menu

Item		Description
Paper Feed Adjust A	Pattern	<p>Use this setting if you are unable to resolve banding issues (horizontal striped lines or uneven colors) in the standard print area (for cut sheets, the area excluding the 1 to 2 cm strip at the bottom of the paper) even after head cleaning or head alignment.</p> <p><b>Pattern selected</b> Press the OK button to print an adjustment pattern. Look for the adjustment pattern with the lightest colors from rows A to D, and enter the value.</p> <p>In the following example image, "3" is the best choice.</p> <div data-bbox="794 611 1297 891" style="text-align: center;"> </div> <p>When the adjustment pattern has been printed, a screen where you can enter the number is displayed on the control panel. Use the ▼/▲ buttons to enter the numbers in order, and then press the OK button.</p> <p><b>Value selected</b> Choose an adjustment between -0.70 and +0.70%.</p> <p>Selecting too small a value causes dark bands; adjust the amount upward. Similarly, choosing too large a value causes white bands; adjust the amount downward.</p>
	Value	
Paper Feed Adjust B	-0.70 to +0.70%	<p>Adjusts the paper feed adjustment value for the 1 to 2 cm region at the bottom of the cut sheets (the bottom area of the paper).</p> <p>Adjust this value if you notice any banding in this region of the paper.</p> <p>Selecting too small a value causes dark bands; adjust the amount upward. Similarly, choosing too large a value causes white bands; adjust the amount downward.</p> <p>This setting is ignored when printing on roll paper.</p>
Drying Time	0.0 to 10.0 sec	<p>You can set the time to pause the print head between each print head pass to allow the ink to dry. Depending on the ink density or paper type, the ink may take a while to dry. If the ink blurs on the paper, set a longer time for drying the ink.</p>
Paper Suction	-4 to -1, Standard*	<p>It is important to choose the appropriate amount of suction for the paper used in order to maintain the correct distance between the paper and the print head. Choosing too high a value for thin or soft paper will increase the distance between the paper and the print head, causing print quality to decline or preventing the paper feeding correctly. In such cases, you will need to lower the paper suction. The suction power is weakened when the parameter is lowered.</p>
Set Roll Paper Tension	Normal*	<p>If wrinkles appear in the roll paper while printing, select <b>High</b> or <b>Extra High</b>.</p>
	High	<p>It is not necessary to set this option for cut sheets.</p>
	Extra High	

### Using the Control Panel Menu



Item		Description
Remove Skew	On*	Select whether to enable (On) or disable (Off) paper skew reduction while printing on roll paper.
	Off	It is not necessary to set this option for cut sheets.

## Printer Setup

\* Default setting

Item		Description
Platen Gap	Narrow	Select the platen gap, which is the distance between the print head and the paper. Normally, select <b>Standard</b> . Select a wider setting if print results are scratched or smudged. If, upon performing head alignment, you feel that it is still not completely aligned, select <b>Narrow</b> .
	Standard*	
	Wide	
	Wider	This setting is cleared when the printer is turned off. When the printer is turned back on, this setting operates at the factory default setting.
	Widest	
Paper Size Check	On*	Choose whether the printer automatically detects ( <b>On</b> ), or does not automatically detect ( <b>Off</b> ), the width of the media. We generally recommend to operate with this setting set to <b>On</b> . Try choosing <b>Off</b> if a paper setting error is displayed when the paper is correctly loaded. Note, however, that the printer may print outside the paper when <b>Off</b> is selected. If it prints beyond the edges of the paper, the inside of the printer becomes dirty with ink.
	Off	
Paper Skew Check	On*	If <b>On</b> is selected, an error will be displayed in the control panel and printing will stop if the paper is skewed; select <b>Off</b> to disable this feature. <b>On</b> is recommended in most circumstances as skewed paper may cause the printer to jam.
	Off	
Auto Nozzle Check	Auto Cleaning Setting	On:Periodically* On:Every Job Off
	Auto Cleaning Times	Set the timing for performing an Auto Nozzle Check that will run before printing starts. <b>On:Periodically:</b> Checks at fixed intervals at a timing determined by the printer. <b>On:Every Job:</b> Checks at each job. <b>Off:</b> Checks only under specific conditions.  Auto Nozzle Check sets the timing that you want the printer to check the status of the nozzles, and if clogged nozzles are detected, sets the number of times to perform auto cleaning. If the nozzles are not clogged, cleaning is not performed. 📄 <a href="#">"Automatically detecting clogged nozzles" on page 122</a>
		1 to 3 (1*) When set to <b>On</b> in <b>Auto Cleaning Setting</b> , sets the number of times to automatically repeat cleaning if clogged nozzles are detected.

## Using the Control Panel Menu

Item		Description
Timer Cleaning	6 to 60 hours	<p>When the following operations are done after the set time has passed from the time the last print was completed, the status of the nozzles is checked. If clogged nozzles are detected, cleaning is done automatically.</p> <ul style="list-style-type: none"> <li><input type="checkbox"/> The printer is turned on.</li> <li><input type="checkbox"/> The printer returns from sleep mode.</li> </ul>
	Off*	
Print Nozzle Pattern	Every 10 pages*	This setting is effective for roll paper only.
	Every Page	Prints a nozzle check pattern at the top of the page after printing every page or every 10 pages.
	Off	You can check by viewing the pattern after printing, and determine if there are any problems in the print results before and after printing.
Auto Black Ink Change	Manual*	<p>If the black ink type setting in the printer and the printer driver differ, it can be changed automatically to the selected type by the printer driver.</p> <p> <a href="#">"Changing the Type of Black Ink" on page 53</a></p> <p><b>Auto:</b> The black ink type is changed automatically, and printing is performed.</p> <p><b>Manual:</b> An error message is displayed on the control panel's screen, and printing is paused.</p> <p> <a href="#">"What to do When a Message is Displayed" on page 141</a></p>
	Auto	
BK Ink Change Setting	Normal*	<p>When you select <b>Quick</b>, you can reduce the time necessary for changing the black ink type. However, when using the black ink immediately after changing, glossy sections may be uneven.</p> <p>Select <b>Normal</b> to maintain print quality immediately after changing the blank ink type.</p>
	Quick	
Calibration Setting	On*	You can make settings whether to enable the calibration data for Epson Color Calibration Utility.
	Off	For details on the calibration procedure and so on, see the software manual.
Initialize Settings	Yes	If <b>Yes</b> is selected, the <b>Printer Setup</b> is restored to default values.
	No	

## Printer Status

Item	Description
Firmware Version	You can see the firmware version.
Print Status Sheet	Press the OK button to print a list of current printer settings. Choose this option to view settings at a glance.
Calibration Date	Displays the latest Epson Color Calibration Utility execution log. You can check details on operations and so on in Epson Color Calibration Utility.

## Using the Control Panel Menu

Item	Description
Total Prints	You can see the total number of pages you have printed (up to 6 figures).
Print Job Information	You can print the job information saved in the printer (up to 10 jobs).

## SpectroProofer

Item	Description	
SProofer Status	Device Version:ILS	Displays the version of the ILS installed on the mounter.
	Calibration Tile S/N	Displays the calibration tile serial number of the ILS installed on the mounter.
	Device Temperature	Displays the temperature of the ILS installed on the mounter.
	Firmware Version	Displays the version of the mounter.
	Air Temperature	Displays the air temperature around the mounter.
	Backing Color	Displays the backing colors installed in the mounter. If the color differs from the actual color, check the status of the backing and make sure it is installed correctly. For details on installing the <i>SpectroProofer Mounter 17</i> , see the Setup Guide (booklet).
	Calibration Status	The status of the ILS calibration appears as <b>Successful</b> or <b>Failed</b> .

## Network Setup

You can make settings for the network connection. After setting the items, press the ◀ button to return to the previous screen. The network is reset and a network connection is available after 40 seconds. This setting is not displayed while resetting. Also, you cannot execute **Print Status Sheet** without doing a restart.

\* Default setting

Item	Description
Network Settings	The following items only appear when <b>Show</b> is selected.
Hide*	
Show	
IP Address Setting	Select whether to use DHCP to set the IP address ( <b>Auto</b> ), or to set the address manually ( <b>Panel</b> ). When you select <b>Panel</b> , the <b>IP, SM, DG Setting</b> below is displayed.
Auto*	
Panel	
IP, SM, DG Setting	You can set the IP address, Subnet Mask, and Default Gateway. Contact your system administrator for detailed information.
Print Status Sheet	Press the OK button to print a list of the <b>Network Setup</b> . Use this information for a complete overview of network settings.
Init Network Setting	Press the OK button to restore all <b>Network Setup</b> content to default values.

## Using the Control Panel Menu

## Preferences

\* Default setting

Item		Description	
Language	Japanese, English, French, Italian, German, Portuguese, Spanish, Dutch, Russian, Korean, Chinese	Select the language used on the control panel's screen.	
Length Units	Metric*	Select the unit of length which is displayed on the control panel's screen or printed on the patterns.	
	Feet/Inch		
Temperature Units	°C*	Select the temperature units used in the control panel display.	
	°F		
Maintenance Alert	Disable*	Sets the type of running low warnings to be displayed by the alert lamp.  If set to <b>Disable</b> , the alert lamp does not display any running low warnings.	
	Ink	The alert lamp flashes when running low on ink.	
	Maintenance Box	The alert lamp flashes when <b>Maintenance Box</b> 1/2 does not have enough empty space.	
	Ink Or Maint Box	The alert lamp flashes when running low on ink or when <b>Maintenance Box</b> 1/2 does not have enough empty space.	
	Paper	If either <b>Roll Paper Remaining</b> or <b>Cut Sheet Remaining</b> is set, the alert lamp flashes when either of these reaches their respective warning levels.	
	All	The alert lamp flashes when running low on ink, when <b>Maintenance Box</b> 1/2 does not have enough empty space, or when running low on paper.	
Cut Sheet Remaining	Off*	Choose whether or not to show <b>(On/Off) Cut Sheet Remaining</b> in the Menu. When set to <b>On</b> , you can set the number of pages to trigger a running low warning and the number of pages loaded in the paper cassette.	
	On		
Sleep Mode	5 minutes, 15 minutes*, 60 minutes, 120 minutes, 210 minutes	The printer will enter sleep mode if no errors have occurred, no print jobs have been received, and no actions are performed on the control panel for an extended period of time. This setting selects the amount of time until the printer enters sleep mode.   <a href="#">"Power Saving Settings" on page 55</a>	
Power Management	Power Off Timer	Disable	The printer turns off automatically when there are no errors, no print jobs being received, and no control panel or other operations are performed for eight hours.
		Enable*	
	Time To Off	1 to 24 hours (8*)	The delay before the printer turns off can be selected from values between 1 and 24 hours in increments of 1 hour.  If you do not want the printer to automatically turn itself off, set <b>Power Off Timer</b> to <b>Disable</b> .



## Using the Control Panel Menu

---

## Administrator Menu

\* Default setting

Item		Description
Powerful Cleaning	All Nozzles, C/VM, PK(MK)/LY, OR/GR, LGY(LLK)/Y, VLM/LC	Performs more powerful cleaning than <b>Head Cleaning</b> from the <b>Maintenance</b> menu. Check the ink colors with faint or missing segments in the check pattern, and then specify which nozzles to clean. <ul style="list-style-type: none"> <li><input type="checkbox"/> If there are faint or missing segments in all colors: Select <b>All Nozzles</b>.</li> <li><input type="checkbox"/> If there are faint or missing segments in only a few colors: Select the specific ink colors you want to clean.</li> </ul>
Clock Setting	MM/DD/YY HH:MM	Set the printer's built-in clock. The time provided by the clock is used when printing logs and status sheets.
Reset All Settings		Pressing the OK button restores all settings, such as settings in the menus on the control panel and paper settings, to their factory settings.

# Maintenance

## Print Head Maintenance

Do print head maintenance if white lines appear in your print outs, if the printouts are dirty, or if you any have problems with the printed results.

### Maintenance Operations

You can perform the following printer maintenance functions for maintaining the print head in good condition to ensure the best print quality. Carry out appropriate maintenance depending on the print results and situation.

#### Automatically detecting clogged nozzles

The printer has functions that allow it to automatically detect the position of clogged nozzles in the print head and perform cleaning without having to print a nozzle check pattern.

##### Note:

- ❑ This function does not guarantee 100% detection of clogged nozzles.
- ❑ A small amount of ink is consumed when detecting clogged nozzles.
- ❑ Ink is consumed when performing automatic cleaning.

You can set the following items on the Printer Setup menu and the Maintenance menu.

 [“Maintenance” on page 111](#)

 [“Printer Setup” on page 117](#)

#### Auto Nozzle Check

When this is set to On, the status of the nozzles is checked at the following times. When clogged nozzles are detected, cleaning is performed automatically the number of times set on the control panel.

- ❑ When printing starts (periodically or every job)

- ❑ Before and after head cleaning

#### Important:

Even if **Auto Cleaning Setting** from **Auto Nozzle Check** is set to **Off**, an auto nozzle check is always performed at the following times.

- ❑ **After initial ink charging**  
An auto nozzle check is performed after ink charging to check the status of the nozzles. If clogged nozzles are detected, auto cleaning is performed once.
- ❑ **Before changing the type of black ink**  
Since black inks cannot be changed correctly if nozzles are clogged, an auto nozzle check is performed. If nozzles are clogged, auto cleaning is performed (up to three times) until the nozzles are cleared regardless of the **Auto Cleaning Times** setting.
- ❑ **An auto nozzle check is done after the **Paper Jam** message is displayed on the control panel's screen and the printer is turned back on because a paper jam may cause the nozzles to clog. If the nozzles are clogged, Auto Cleaning is done just once.**

#### Timer Cleaning

After the set time has passed from the end of the previous print job, the status of the nozzle is checked when the following operations are performed. If clogged nozzles are detected, cleaning is done automatically.

- ❑ The printer is turned on
- ❑ The printer returns from sleep mode

#### Printless Nozzle Check

If you execute this, the status of the nozzles is checked and the results of the clogged nozzle detection are displayed on the control panel. When clogged nozzles are detected, if you then press the  button, cleaning is done automatically.

 [“Maintenance” on page 111](#)

#### Checking for clogged nozzles using the printed check pattern

The following two methods are available.

## Maintenance

### On-Demand Nozzle Check Pattern

We recommend printing a nozzle check pattern and performing a visual inspection before printing when the printer has not been used for an extended period or when printing important print jobs. Visually inspect the printed pattern and clean the print head if you notice faint or missing areas.

[“Checking for clogged nozzles” on page 123](#)

### Print Nozzle Pattern function (for roll paper only)

A nozzle check pattern is printed at the top of the specified page (every page or every 10 pages). When printing a large reel of jobs, or when printing important print jobs, you can check that there are no clogged nozzles and determine if there are any problems in the print results before and after printing.

[“Printer Setup” on page 117](#)

## Cleaning the print head

This function cleans the surface of the print head and clears clogged nozzles.

[“Cleaning the print head” on page 124](#)

### Check And Clean Nozzle

Perform this to check the status of the nozzles and automatically clean only the nozzle arrays that are clogged.

[“Maintenance” on page 111](#)

### All Nozzles/Select Nozzles

All Nozzles does Head Cleaning to all the nozzles. Select Nozzles lets you select for which nozzles to do Head Cleaning. Select which one according to the results of the printed check pattern. You can also select whether to do Normal Cleaning or Heavy Cleaning. Select Heavy Cleaning if the nozzles do not unclog even after doing Normal Cleaning multiple times.

[“Maintenance” on page 111](#)

## Adjusting print misalignments (Head Alignment)

This function adjusts the print misalignment. Use this if lines are misaligned or print results are grainy.

[“Adjusting print misalignments \(Head Alignment\)” on page 126](#)

## Checking for clogged nozzles

Nozzle checks can be performing from a computer or using printer's control panel.

### From the computer

Explanations in this section use the Windows printer driver as an example.

Use Epson Printer Utility 4 for Mac OS X.

[“Epson Printer Utility 4 Functions” on page 64](#)

- 1 Make sure that the roll paper or a cut sheet of A4 size or larger is loaded in the printer.
  - [“Loading and Removing the Roll Paper” on page 30](#)
  - [“Loading Cut Sheets” on page 38](#)

- 2 Click **Nozzle Check** from the **Utility** tab in the printer driver's **Properties** (or **Printing preferences**) screen.

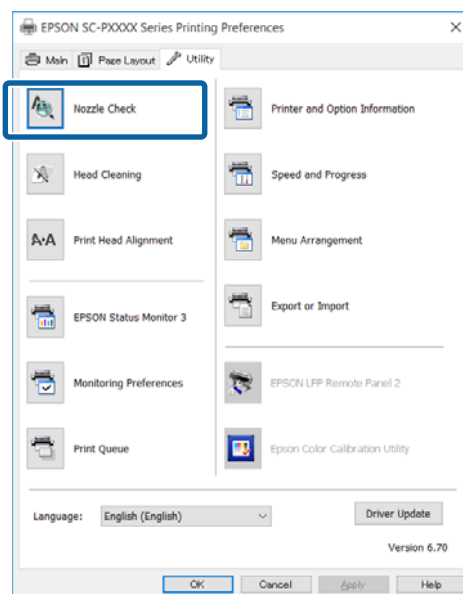

- 3 Click **Print**.  
The nozzle check pattern is printed.
- 4 Check the nozzle check pattern.  
If there is no problem: click **Finish**.  
If there is a problem: click **Clean**.

## Maintenance

After printing a nozzle check pattern, make sure that the nozzle check pattern printing is complete before printing your data or cleaning the print head.

### From the printer

This section explains the procedure to print and check a check pattern. To check the results without printing a check pattern, select **Printless Nozzle Check** in step 4, and then follow the on-screen instructions.

Buttons that are used in the following settings

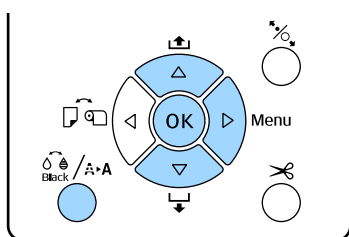

- 1 Make sure that the roll paper or a cut sheet of A4 size or larger is loaded in the printer.  
Choose a paper type that matches the paper in the printer.  
[“Paper menu” on page 106](#)
- 2 Check that it is ready to print. Press the button. The Maintenance menu will be displayed.
- 3 Press the buttons to select **Nozzle Check**, and then press the button.
- 4 Press the buttons to select **Print Check Pattern**, and then press the OK button.
- 5 Press the OK button to print a check pattern.  
Review the printed check pattern while referring to the following section.

#### Example of clean nozzles



There are no gaps in the nozzle check pattern.

#### Example of clogged nozzles



If any segments are missing in the nozzle check pattern, perform head cleaning.

[“Cleaning the print head” on page 124](#)

## Cleaning the print head

Although head cleaning can be performed from the computer or the printer, the cleaning procedures differ as explained below.

### From the computer

All nozzles are cleaned.

[“From the computer” on page 125](#)

### From the printer

You can clean all nozzles or select only those nozzles for which the printed nozzle check pattern indicates a problem.

[“From the printer” on page 125](#)

## Notes on Head Cleaning

### Ink is consumed during head cleaning.

Clean the print head only if print quality declines; for example, if the printout is blurry or the color is incorrect or missing.

### When cleaning all nozzles, ink is consumed from all colors.

Even if you are using only black inks for black and white printing, color inks are also consumed.

### Prepare a new maintenance box if there is not enough empty space in the box.

If you repeat head cleaning several times in a short period, the ink in the maintenance box may become full soon as ink does not evaporate quickly from the maintenance box.

### Powerful Cleaning consumes much more ink than Head Cleaning in the Maintenance menu.

Check the remaining ink level in advance, and prepare a new ink cartridge before you start cleaning if the ink is low.

### If the nozzles are still clogged after performing Powerful Cleaning, turn off the printer and leave it overnight or longer.

When left for some time, the clogged ink may dissolve.

If the nozzles are still clogged, contact your dealer or Epson Support.

## Maintenance

## From the computer

Before starting this procedure, be sure to read the following:

 [“Notes on Head Cleaning” on page 124](#)

Explanations in this section use the Windows printer driver as an example.

Use Epson Printer Utility 4 for Mac OS X.

 [“Using Epson Printer Utility 4” on page 64](#)

- 1 Click **Head Cleaning** from the **Utility** tab in the printer driver's **Properties** (or **Printing preferences**) screen.

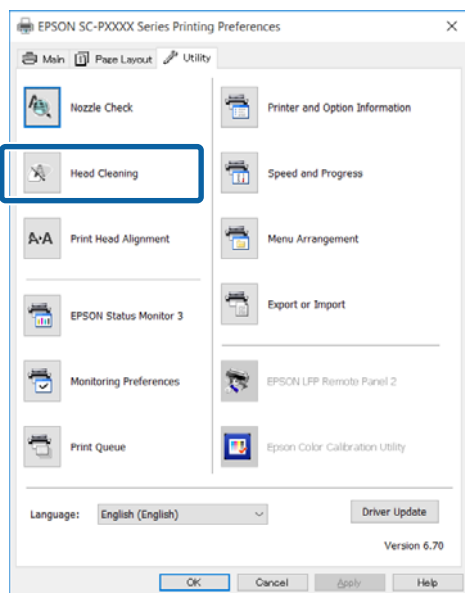

- 2 Click **Start**.  
Head Cleaning starts. Head Cleaning takes about 8 to 13 minutes.
- 3 Click **Print Nozzle Check Pattern**.  
Confirm the nozzle check pattern.  
If you see any faint or missing segments in the nozzle check pattern, click **Clean**.  
If you cannot clear the clogged nozzles even after repeating cleaning several times in succession, select **Heavy** from **Head Cleaning** on the printer's control panel.

 [“From the printer” on page 125](#)





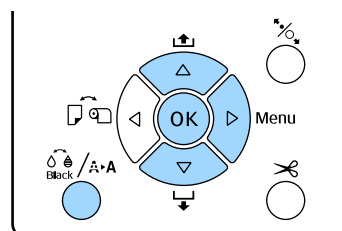

## From the printer

Before starting this procedure, be sure to read the following:

 [“Notes on Head Cleaning” on page 124](#)

Buttons that are used in the following settings



- 1 Check that it is ready to print. Press the  button. The Maintenance menu will be displayed.
- 2 Press the / buttons to select **Head Cleaning**, and then press the  button.
- 3 Press the / buttons to select the type of cleaning.



**When you want to check for clogs, and then do cleaning automatically**



Select **Check And Clean Nozzle** and press the  button. Press the **OK** button to start detecting clogs. When cleaning is complete, **Ready** appears on the screen.

**When you see faint or missing segments in all colors in the check pattern**

Select **All Nozzles**, and then press the  button.

**When you see faint or missing segments in some colors in the check pattern**

Select **Select Nozzles**, and then press the  button. Press the / buttons to select the colors that need cleaning, and then press the **OK** button.

- 4 Select the cleaning strength. To start, select **Normal**.  
Press the / buttons to select the strength, and then press the **OK** button to start cleaning.  
Head Cleaning takes about 2 to 17 minutes. When cleaning is complete, **Ready** appears on the screen.

## Maintenance

**Note:**

Cleaning depends on the status of the nozzles and the **Auto Cleaning Times** setting. This function can take up to about 50 minutes.

- 5** Print a check pattern, and check the results.

 [“Checking for clogged nozzles” on page 123](#)

If the nozzles are still clogged, repeat steps 1 to 4 several times. If the nozzles are still clogged after repeating the procedure several times in succession, repeat from step 1, and select **Heavy** in step 4.

If the nozzles are still clogged after performing **Heavy**, see the following section and perform **Powerful Cleaning**.

**Powerful Cleaning**

Before starting this procedure, be sure to read the following:

 [“Notes on Head Cleaning” on page 124](#)

- 1** Press the ► button to display the menu.
- 2** Press the ▼/▲ buttons to select **Administrator Menu**, and then press the ► button.
- 3** Press the ▼/▲ buttons to select **Powerful Cleaning**, and then press the ► button.

**When you see faint or missing segments in all colors in the check pattern**

Select **All Nozzles**, and then press the OK button.

**When you see faint or missing segments in some colors in the check pattern**

Press the ▼/▲ buttons to select the colors that need cleaning, and then press the OK button.

- 4** A confirmation dialog will be displayed. Select **Yes**, and then press the OK button to start Powerful Cleaning.

Powerful Cleaning takes about 6 to 31 minutes.

When Powerful Cleaning is complete, Ready appears on the screen.

- 5** Print a check pattern, and inspect the results to determine if the problem has been resolved.

 [“From the printer” on page 124](#)

**Adjusting print misalignments (Head Alignment)**

If lines are misaligned or print results are grainy, perform Head Alignment to adjust the print misalignment.

The print head fires ink when moving to the left and to the right while printing. Since there is a short distance (gap) between the paper surface and the print head, a print misalignment may occur due to the paper thickness, changes in temperature or humidity, and internal inertia while the print head moves.

Although Head Alignment can be performed from the computer or the printer, the alignment procedures differ as explained below.

**From the computer**

In auto adjustment (Bi-D 5-color), an adjustment pattern is printed on the loaded paper, read by the sensors, and the optimum adjustment value is registered to the printer. It takes about 3 minutes to complete the adjustments.

In most cases, head alignment can be performed successfully with just this operation. We normally recommend this method as this is the simplest method.

 [“From the computer” on page 127](#)

**From the printer**

You can perform auto or manual adjustments. There are four types of adjustment patterns.

Item Name	Explanation
<b>Uni-D</b>	Adjusts differences in the print position for uni-directional printing for each color based on Light Cyan.
<b>Bi-D 5-color</b>	Use Vivid Magenta, Black, Orange, Light Light Black, and Light Cyan ink colors to align the print head for bi-directional printing.  Either Matte Black or Photo Black ink is used for Black, based on the type of black ink currently selected.

## Maintenance

Item Name	Explanation
<b>Bi-D 2-color</b>	Adjusts differences in the print position for bi-directional printing for two colors, Light Cyan and Vivid Light Magenta.
<b>Bi-D All</b>	Adjusts differences in the print position for bi-directional printing for all colors.

- ❑ Auto adjustment  
The sensor reads the adjustment pattern printed on the paper, and automatically registers the optimum adjustment value to the printer. It takes about 3 to 4 minutes to complete the adjustments. The time required varies depending on the menu selected.
- ❑ Manual adjustment  
Visually check the adjustment patterns printed on the paper, and enter the optimal adjustment values. Use this if you cannot perform auto adjustment, or if you are not satisfied with the adjustment results when using Auto. It takes about 3 to 8 minutes to print an adjustment pattern. The time required varies depending on the menu selected.

 [“From the printer” on page 128](#)

### Notes on Head Alignment

#### Adjustments are made depending on the paper loaded in the printer.

Make sure that the paper is loaded correctly, and that a **Paper Type** is selected.

 [“Loading and Removing the Roll Paper” on page 30](#)

 [“Loading Cut Sheets” on page 38](#)

When adjusting using commercially available paper, make sure you register the custom paper in advance.

 [“Before Printing on Commercially Available Paper” on page 174](#)

#### Make sure that nozzles are not clogged.

If nozzles are clogged, adjustment may not be performed correctly. Print the check pattern, perform a visual inspection, and perform head cleaning if necessary.

 [“Checking for clogged nozzles” on page 123](#)

#### Auto adjustment cannot be performed when using the following paper.

- ❑ Plain Paper
- ❑ Transparent or colored paper

Perform manual adjustment when using these types of paper.

 [“From the printer” on page 128](#)

#### When performing auto adjustment, make sure that no external light (direct sunlight) enters the printer.

Otherwise, the printer's sensors may not read the adjustment pattern correctly. If auto adjustment cannot be performed even after making sure no external light is entering the printer, perform manual adjustment.

 [“From the printer” on page 128](#)

### From the computer

Before starting this procedure, be sure to read the following:

 [“Notes on Head Alignment” on page 127](#)

Explanations in this section use the Windows printer driver as an example.

Use Epson Printer Utility 4 for Mac OS X.

 [“Using Epson Printer Utility 4” on page 64](#)

**1**

Make sure that the roll paper or a cut sheet of A4 size or larger is loaded in the printer.

 [“Loading and Removing the Roll Paper” on page 30](#)

 [“Loading Cut Sheets” on page 38](#)

When adjusting using commercially available paper, make sure you register the Custom Paper in advance.

 [“Before Printing on Commercially Available Paper” on page 174](#)



## Maintenance

- 2 Click **Print Head Alignment** from the Utility tab in the printer driver's **Properties** (or **Print Preferences**) screen.

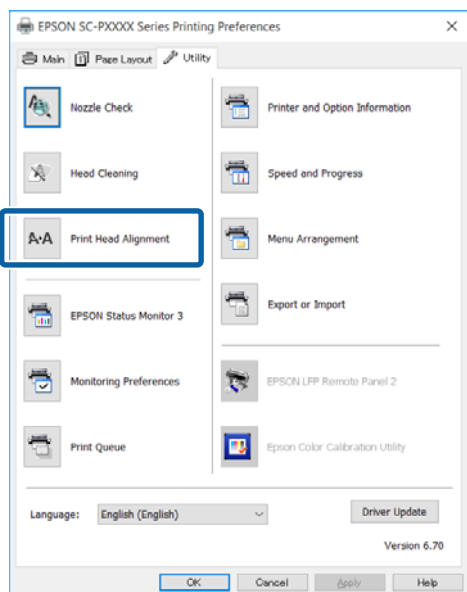

Follow the on-screen instructions.

The sensor reads the adjustment pattern while it is printing, and automatically registers the optimum adjustment value to the printer.

Check the adjustment results to confirm if graininess or misalignment recurs in the printed image.

If you are not satisfied with the adjustment results, perform manual adjustment from the printer.

[“From the printer” on page 128](#)

## From the printer

To perform Head Alignment from the printer, make adjustments in the following order.

- (1) Execute **Paper Thickness**.
- (2) Select automatic or manual adjustment, and then execute the adjustment.

**Note:**

*When printing a Head Alignment pattern, it prints with the black ink currently selected in the printer, regardless of the type of paper loaded.*

*When printing the pattern on glossy paper with Matte Black ink, try not to rub the printed surface as it is difficult to fix Matte Black ink on glossy paper.*

Before starting this procedure, be sure to read the following:

[“Notes on Head Alignment” on page 127](#)

Buttons that are used in the following settings

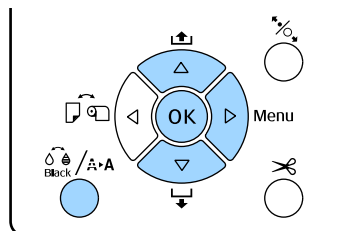

## Setting Paper Thickness

- 1 Make sure that the roll paper or a cut sheet of A4 size or larger is loaded in the printer.  
 [“Loading and Removing the Roll Paper” on page 30](#)

[“Loading Cut Sheets” on page 38](#)

When adjusting using commercially available paper, make sure you register the Custom Paper in advance.

[“Before Printing on Commercially Available Paper” on page 174](#)

- 2 Press the button to display the **Maintenance** Menu.
- 3 Press the buttons to select **Head Alignment**, and then press the button.
- 4 Press the buttons to select **Paper Thickness**, and then press the button.
- 5 Set the **Paper Type** for Epson special media, and set the **Paper Thickness** for commercially available media.

### Epson Special Media

- (1) Press the buttons to select **Paper Type**, and then press the button.
- (2) Press the buttons to select the paper type being used, and then press the OK button.

### Commercially available media

- (1) Press the buttons to select **Paper Thickness**, and then press the button.



**Maintenance**

(2) (2) Press the ▼/▲ buttons to select a paper thickness value between 0.1 to 1.5 mm, and then press the OK button.

For the paper's thickness, check the paper's manual or with your local dealer.

- 6 Press the II·☐ button to close the menu.
- Refer to the instructions for details on how to perform both auto and manual adjustment.

**Aligning the print head automatically**

- 1 Press the  button to display the **Maintenance Menu**.
- 2 Press the ▼/▲ buttons to select **Head Alignment**, and then press the ► button.
- 3 Press the ▼/▲ buttons to select **Alignment**, and then press the ► button.
- 4 Press the ▼/▲ buttons to select **Auto**, and then press the ► button.
- 5 Press the ▼/▲ buttons to select the type of alignment pattern, and then press the ► button.  
If you have already performed Head Alignment from the computer, select **Uni-D**. If you are performing Head Alignment for the first time, select **Bi-D 5-Color**.
- 6 Press the OK button.  
The sensor reads the adjustment pattern while it is printing, and automatically registers the optimum adjustment value to the printer.

**Note:**  
If the results of the **Bi-D 5-Color** alignment are unsatisfactory, execute **Uni-D** alignment. If the results of the **Uni-D** alignment are unsatisfactory, execute **Bi-D All** alignment.

**Aligning the print heads manually**

When doing Manual Alignment, align with **Uni-D** first, and then with **Bi-D 2-Color**. If you want to make more precise adjustments, try **Bi-D All**.

- 1 Press the  button to display the **Maintenance Menu**.

- 2 Press the ▼/▲ buttons to select **Head Alignment**, and then press the ► button.
- 3 Press the ▼/▲ buttons to select **Manual**, and then press the ► button.
- 4 Press the ▼/▲ buttons to select **Uni-D**, and then press the ► button.
- 5 Press the OK button.  
The adjustment pattern is printed on the loaded paper.  
The alignment pattern prints repeatedly from side to side of the paper.

**Note:**  
Multiple adjustment patterns are printed for cut sheets. Once printing the first sheet is complete, load the next sheet of paper.

- 6 Note the numbers of the patterns with the fewest white lines or in which the white lines are most evenly spaced.  
This would be pattern "3" in the example shown in the illustration.

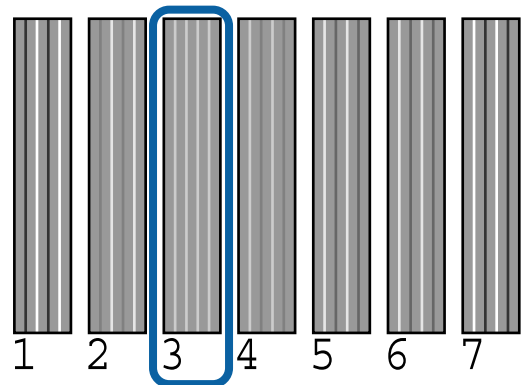

- 7 Check the abbreviation of the colors of ink displayed on the control panel's screen. Press the ▼/▲ buttons to select the number you confirmed in step 6, and then press the OK button.
- 8 Select the numbers for all the colors and then press the OK button.  
When the last color is set, Ready appears on the screen.

## Maintenance

- 9** Next, align with **Bi-D 2-Color**. Do the adjustment again from step 1, but select **Bi-D 2-Color** in step 4, and then do steps 5 to 8.

**Note:**

When Head Alignment is complete, press the  button.

**If you are not satisfied with the adjustment results**

Do the adjustment again from step 1, but select **Bi-D All** in step 4, and then do steps 5 to 8.

## Replacing Consumables

### Replacing Ink Cartridges

If one of the installed ink cartridges is expended, printing cannot be performed. If an ink low warning is displayed, we recommend replacing the ink cartridge(s) as soon as possible.

If an ink cartridge runs out while printing, you can continue printing after replacing the ink cartridge. However, when replacing ink during a print job, you may see a difference in color depending on the drying conditions.

Supported ink cartridges  [“Options and Consumable Products” on page 161](#)

### How to replace

The following procedure uses Matte Black ink as an example. You can use the same procedure to replace all ink cartridges.

 **Important:**

*Epson recommends the use of genuine Epson ink cartridges. Epson cannot guarantee the quality or reliability of non-genuine ink. The use of non-genuine ink may cause damage that is not covered by Epson's warranties, and under certain circumstances, may cause erratic printer behavior. Information about non-genuine ink levels may not be displayed, and use of non-genuine ink is recorded for possible use in service support.*

- 1** Make sure the printer is on.

Maintenance

- 2** Open the cartridge cover.  
Press the groove in the cartridge cover to open the cover.

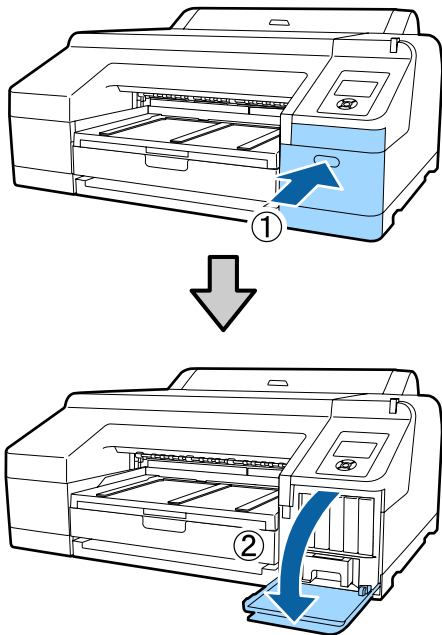

- 3** Push back the ink cartridge that you want to replace.  
You will hear a click and the ink cartridge pops out slightly.

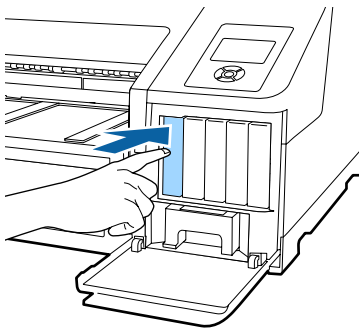

- 4** Carefully pull the cartridge straight out of the slot.

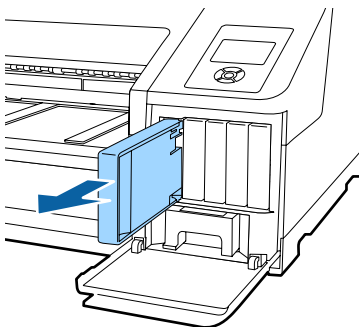

**!** **Important:**

*Removed ink cartridges may have ink around the ink supply port, so be careful not to get any ink on the surrounding area when removing the cartridges.*

- 5** Remove the new ink cartridge from the bag. Shake the ink cartridge for 5 seconds, 15 times horizontally in approximately 5 cm movements as shown in the illustration.

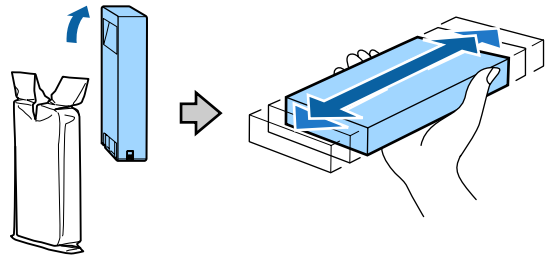

**!** **Important:**

*Do not touch the IC chips on the ink cartridges. You may not be able to print properly.*

- 6** With the ▲ mark on the ink cartridge facing up, press it in until you hear it click.

Match the ink cartridge color with the color label on the back of the cartridge cover.

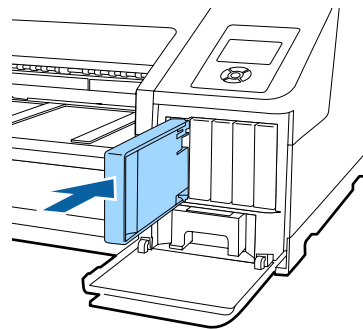

Repeat steps 3 to 6 to replace other ink cartridges.

**!** **Important:**

*Install all ink cartridges into each slot. You cannot print if any of the slots are empty.*

## Maintenance

- 7** Close the cartridge cover.

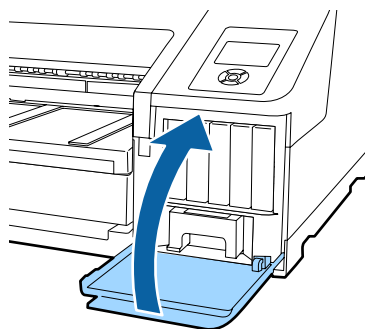

### Replacing Maintenance Box 1 and 2

If the message **Replace Maint Box** or **Not Enough Empty Space** is displayed, replace the specified Maintenance Box.

Supported Maintenance Boxes

[“Options and Consumable Products” on page 161](#)

**!** **Important:**

*Do not attempt to re-use Maintenance Box 1 or 2 that has been removed and left out in the open for a long period of time. The ink on the inside will be dry and hard and will be unable to absorb enough ink.*

### Replacing Maintenance Box 1

The on-screen message reads Maintenance Box 1, however the product name for this consumable is simply Maintenance Box.

**!** **Important:**

*Do not replace Maintenance Box 1 while printing. Waste ink may leak.*

- 1** Open the right-hand side cartridge cover.  
Press the groove in the cartridge cover to open the cover.

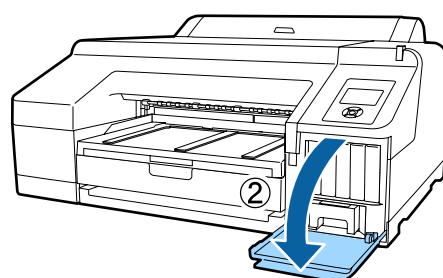
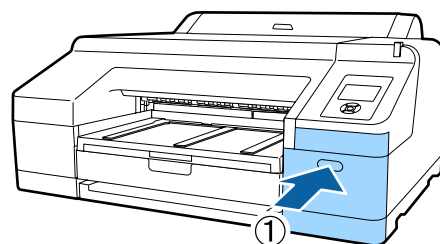

- 2** Pull Maintenance Box 1 out.  
Lifting Maintenance Box 1 up releases the lock, and you can simply pull it straight out.

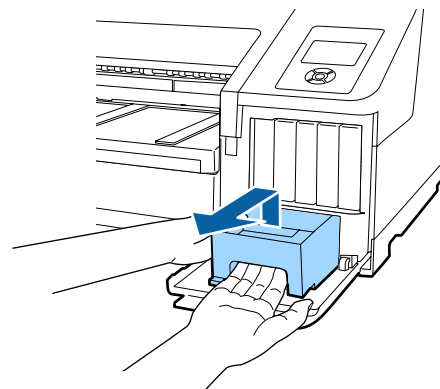

- 3** Place the used Maintenance Box 1 in the clear bag included with your new Maintenance Box 1, and make sure that the zipper is closed tight.

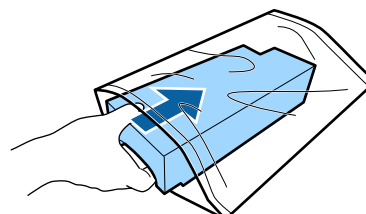

**Maintenance**

**4** Insert the new Maintenance Box 1.

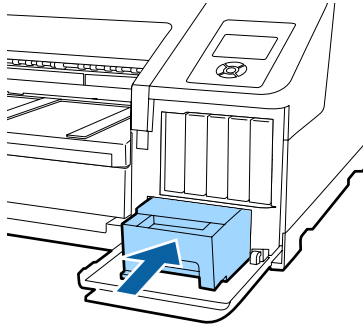

**! Important:**  
 Pay attention to the following since the printer may not operate or print correctly otherwise.

- Do not touch the green IC chip on the side of Maintenance Box 1.
- Do not remove the film from the top of Maintenance Box 1.

**5** Close the cartridge cover.

**Replacing Maintenance Box 2**

The instructions for replacing Maintenance Box 2 (Maintenance Box for borderless printing) are as follows.

The on-screen message reads Maintenance Box 2. However, the product name for this consumable is Borderless Maintenance Box.

**! Important:**  
 Do not replace Maintenance Box 2 while printing. Printing stops if the lock on Maintenance Box 2 is released. If stopped in the middle of printing, colors may vary and/or print quality may decline once printing is resumed.

**1** Remove the output tray.  
 Lift the edge of the output tray slightly to remove it. Also remove the optional SpectroProofer if installed.

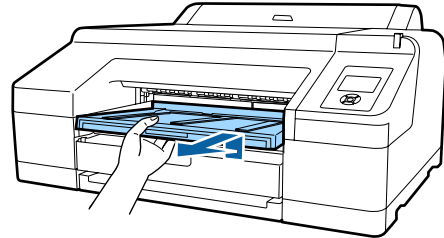

**2** Release the Maintenance Box 2 lock.

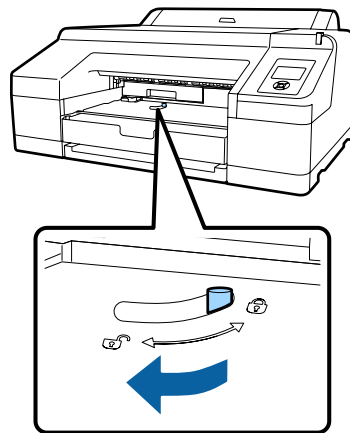

**3** Pull Maintenance Box 2 out carefully so that it does not tilt.

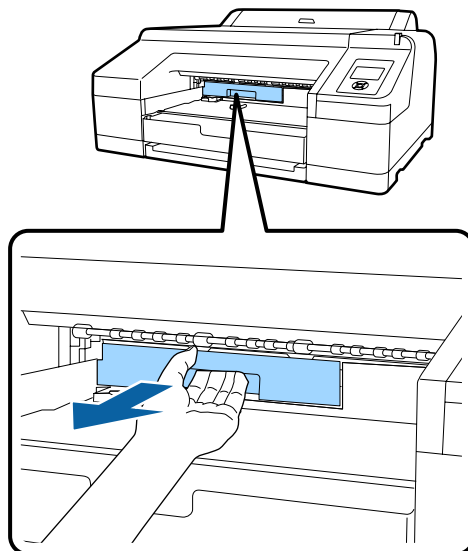

**! Caution:**  
 If ink should get on your skin or in your eyes, wash the affected area with water immediately.

Maintenance

- 4 Place the used Maintenance Box 2 in the clear bag included with your new Maintenance Box 2, and make sure that the zipper is closed tight.

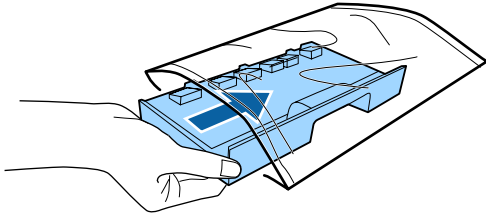

**! Important:**  
 Do not tilt Maintenance Box 2 until it is completely in the clear bag and the zipper is closed. The waste ink may leak and soil the surrounding area.

- 5 Insert the new Maintenance Box 2. Push it in firmly.

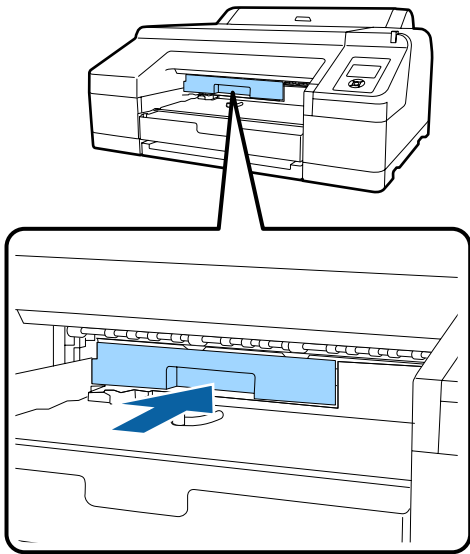

**! Important:**  
 Do not touch the IC chip on the Maintenance Box 2. Doing so may prevent normal operation and printing.

- 6 Set the lock.

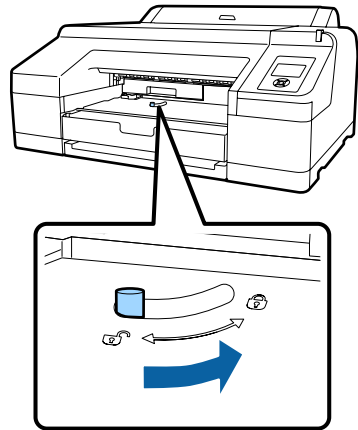

- 7 Attach the output tray. Return optional SpectroProofer if it was installed.

**Replacing the Cutter**

Replace the cutter when it is not cutting paper cleanly.

Supported cutter

[☞ “Options and Consumable Products” on page 161](#)

Use a cross-head screwdriver to replace the cutter. Make sure you have a cross-head screwdriver with you before replacing the cutter.

**! Important:**  
 Take care not to damage the cutter blade. Dropping it or knocking it against hard objects may chip the blade.

- 1 Turn off the printer. If paper is loaded, remove it from the printer.

Maintenance

**2** Open the cartridge covers on the left and right.

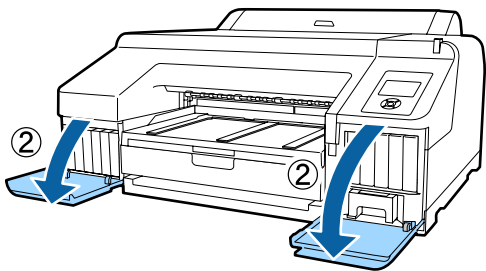
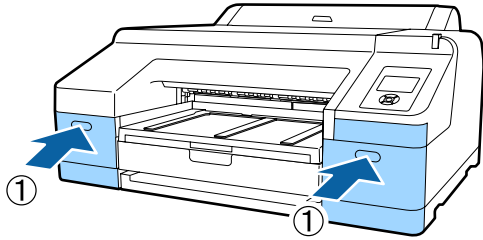

**3** Open the printer cover.

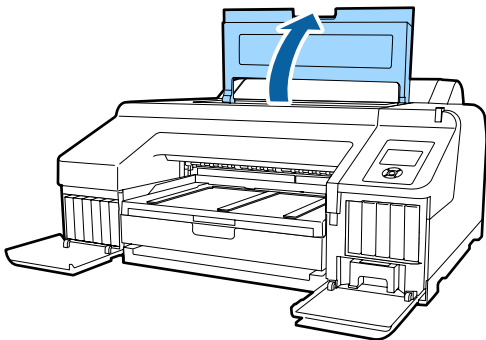

**4** Remove the front cover.  
Use a cross-head screwdriver and remove the four screws holding the front cover in place. Remove the front cover.

Remove when the optional SpectroProofer is installed.

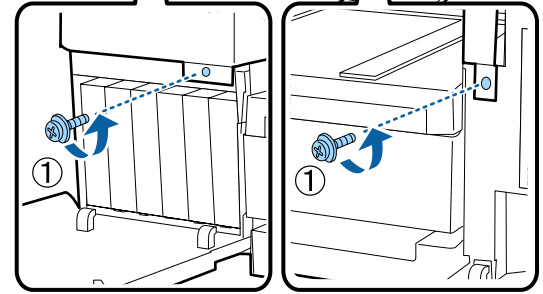
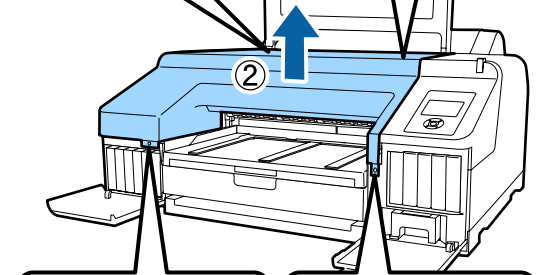
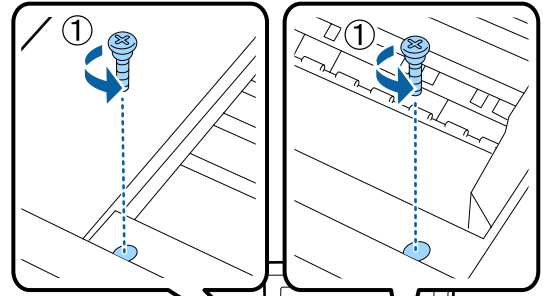

**5** Open the cutter cover.  
Pull the cover towards you while holding down the lock as shown in the figure to open the cover.

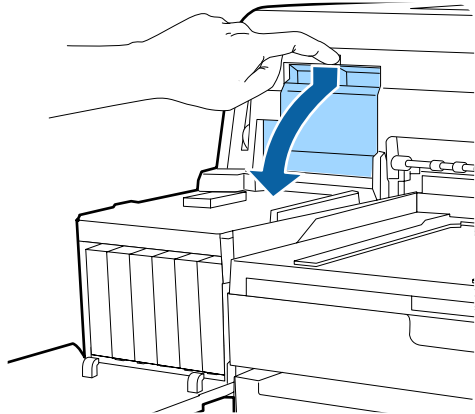

**6** Remove the old cutter from the printer.  
Loosen the screw holding the cutter in place using a cross-head screwdriver and pull the cutter straight out.

Maintenance

**⚠ Caution:**  
 Do not store the cutter within the reach of children. The cutter's blade could cause an injury. Pay careful attention when replacing the cutter.

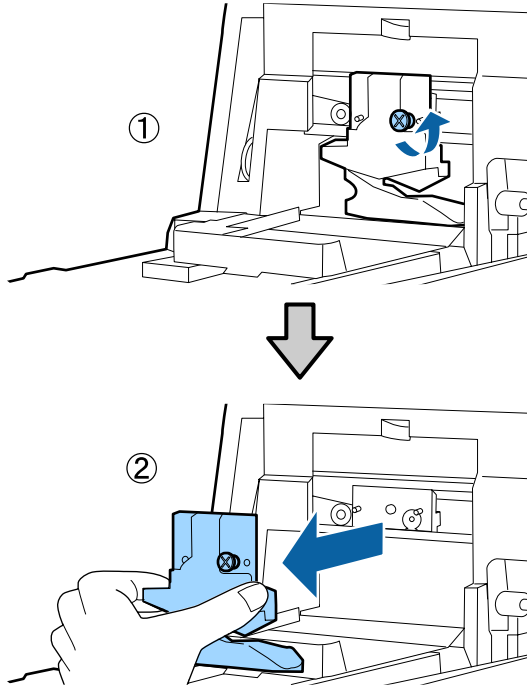

- 7** Install the new cutter.  
 Insert the cutter so that the pin on the printer matches up with the hole on the cutter. Use a cross-head screwdriver to tighten the screw to hold the cutter in place.

**⚠ Important:**  
 Tighten the cutter firmly, otherwise the cut position may be slightly shifted or skewed.

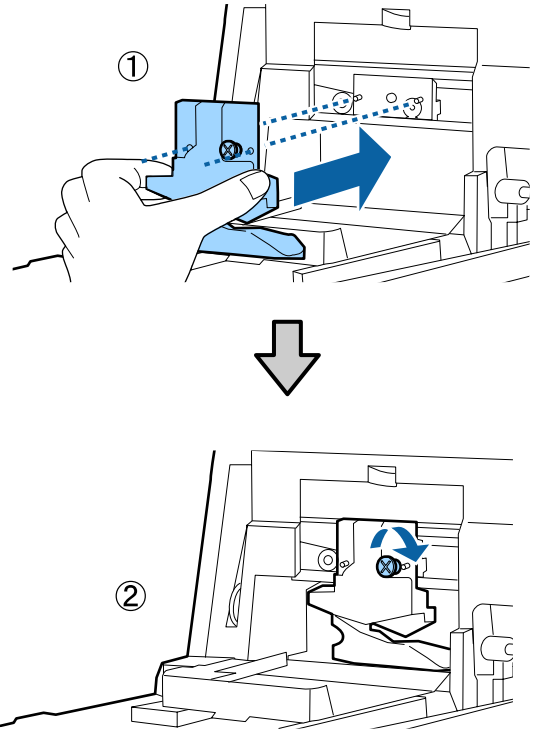

- 8** Close the cover.  
 Push in the cover until you hear the upper portion click into place.

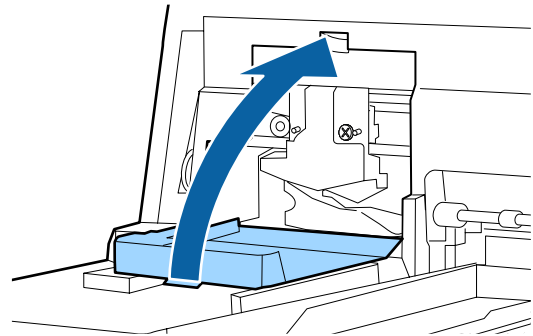

- 9** Return the front cover.  
 Re-insert the four screws that hold the cover in place and use a cross-head screwdriver to tighten them. The shape of the screws differ for the top and the front. Use the screws that come with a washer for the front section (the cartridge cover section).

If you are using the optional SpectroProofer, install the SpectroProofer into place without returning the front cover.

**⚠ Important:**  
 If the front cover is not properly in place, an error occurs and the printer does not respond.



Maintenance

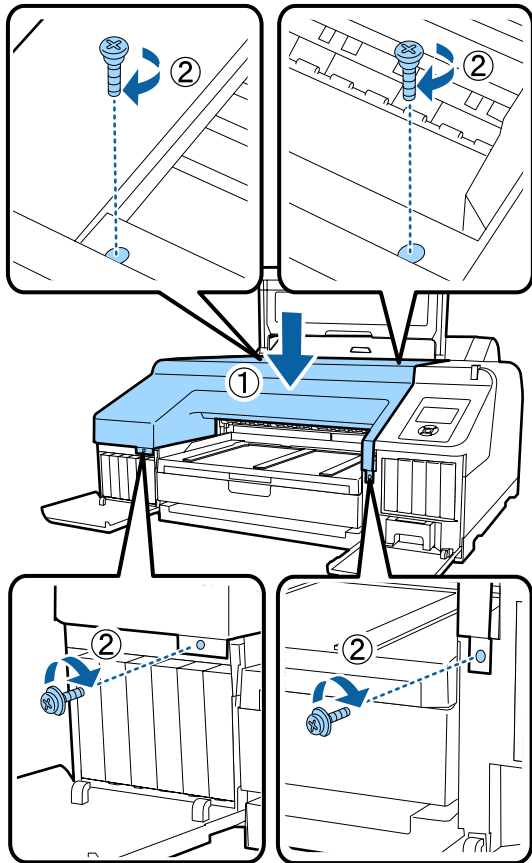

**10** Close the printer cover and the left and right cartridge covers.

## Cleaning the Printer

To keep your printer in optimum operating condition, clean it regularly (about once a month).

In addition, use the dedicated cleaning sheet to clean the roll paper feed slot once a year.

### Cleaning the outside

- 1** Remove any paper from the printer.
- 2** Make sure the printer is turned off and the screen has turned off, and then unplug the power cable from the outlet.
- 3** Use a soft, clean cloth to carefully remove any dust or dirt.

If the printer is particularly dirty, dampen the cloth with water containing a small amount of neutral detergent, and then firmly wring the cloth dry before using it to wipe the printer's surface. Next, use a dry cloth to wipe away any remaining moisture.

**! Important:**

*Never use benzene, thinners, or alcohol to clean the printer. They could cause discoloration and deformities.*

### Cleaning the inside

Perform one of the following cleaning operations if print outs are smudged or soiled.

- Cleaning the roller**  
Perform if roll paper, rear feed, or front feed print outs are smudged or soiled.
- Cleaning the paper cassette printing path**  
Perform if print outs from the paper cassette are soiled or paper particles are on the print out preventing ink from being applied in those areas.

### Cleaning the roller

Follow the steps below to clean the roller by feeding plain paper.

**Maintenance**

- 1 Turn on the printer, and load an A2 or 17 inch wide roll paper.  
[☞ “Loading and Removing the Roll Paper” on page 30](#)
- 2 Press the ▼ button.  
 Paper is fed as long as the button is pressed. If the paper is not soiled, cleaning is complete.

Cut the paper after cleaning is done.

[☞ “Manual cut method” on page 36](#)

**Cleaning the paper cassette printing path**

Follow the steps below to clean any soiled areas by outputting plain paper.

- 1 Load A2 or 17 inch wide cut sheets in the paper cassette.  
[☞ “Loading the Paper Cassette” on page 39](#)
- 2 Check that the printer is turned on, and check that Cut Sheet is selected as the paper type.
- 3 Press the ▼ button.  
 Paper is ejected from the paper cassette.

Repeat step 3 until the paper is not soiled with ink.

**Cleaning the roll paper feed slot**

A cloth is attached to the roll paper feed slot, to catch paper particles and dust that are adhered to the paper surface and edges.

Use the dedicated cleaning sheet in the following procedure to remove dust caught by the cloth in the roll paper feed slot. Always use a new cleaning sheet. Purchase a cleaning sheet, sold separately, when the supplied cleaning sheet has been used.

[☞ “Options and Consumable Products” on page 161](#)



**Important:**

*Clean the roll paper feed slot using a cleaning sheet approximately once a year.*

- 1 Turn on the printer by pressing the ⏻ button.
- 2 Press the ◀ button to display the **Paper Type** Menu.
- 3 Press the ▼/▲ buttons to select **Roll Paper / Cut** or **Roll Paper / No Cut**, and then press the OK button.
- 4 Press the ⌘ button.
- 5 Open the roll paper cover.

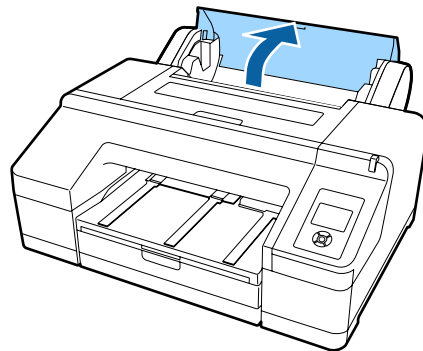

**Note:**

*Close this while the paper support is open.*

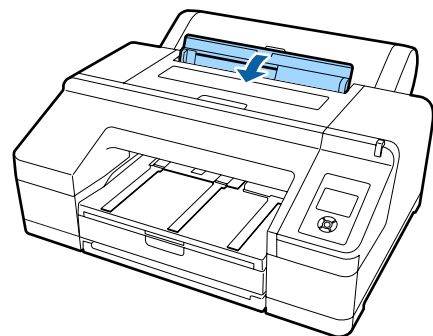

Maintenance

- 6 Remove the protective sheet that is on the cleaning sheet.  
The gray area indicated by A is adhesive face. Do not touch it with your hands or anything else.

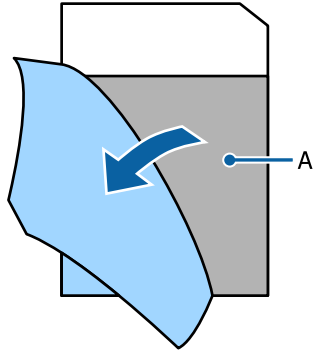

- 7 Insert the cleaning sheet until it reaches the end of the roll paper feed slot, and then pull it out. Repeat this two or three times.  
To clean the roll paper feed slot from end to end, do it several times on the right side, center, and left side sections.

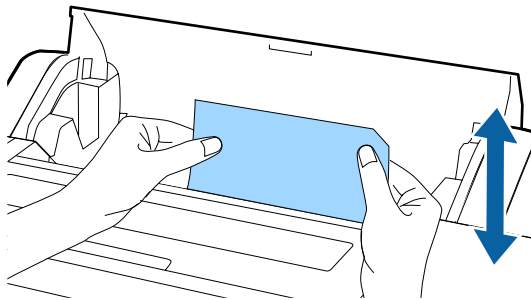

- 8 Press the  $\frac{\%}{\%}$  button. If you want to stop a job as is, press the  $\text{O}$  button on the printer to turn off the power. If you want to continue, see the following, according to the job to be done.

[“Loading Roll Paper” on page 31](#)

[“Loading Cut Sheets” on page 38](#)

**Note:**  
If the cleaning sheet gets fed, press the  $\frac{\%}{\%}$  button and then remove the cleaning sheet.

You cannot reuse a cleaning sheet that has been used once.

Cleaning Inside the Printer

- 1 Make sure the printer is turned off and the screen has turned off, and then unplug the power cable from the outlet.
- 2 Leave the printer for a minute.
- 3 Open the printer cover and use a soft, clean cloth to carefully wipe away any dust or dirt inside the printer.

Wipe the pink part shown in the following illustration. To avoid spreading the dirt, wipe from the inside to the outside. If there is a serious dirt problem, clean it using a soft, clean cloth dampened with a mild detergent. Then, wipe the inside of the printer with a dry, soft cloth.

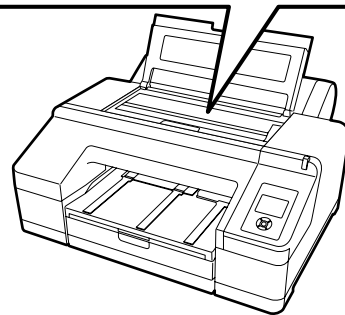
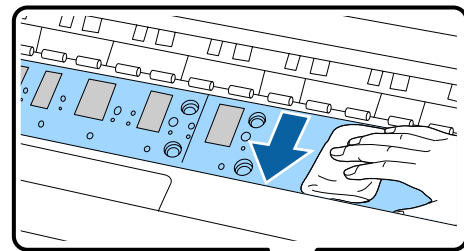

**Important:**

- When cleaning, do not touch the roller and the ink absorption parts (gray parts) in the illustration above; otherwise, prints may be soiled.
- Be careful not to touch the ink tubes inside the printer, otherwise, the printer may be damaged.

## Maintenance

- 4 If any paper particles (that looks like white powder) accumulates on the platen, use something like a cocktail stick to push it in.

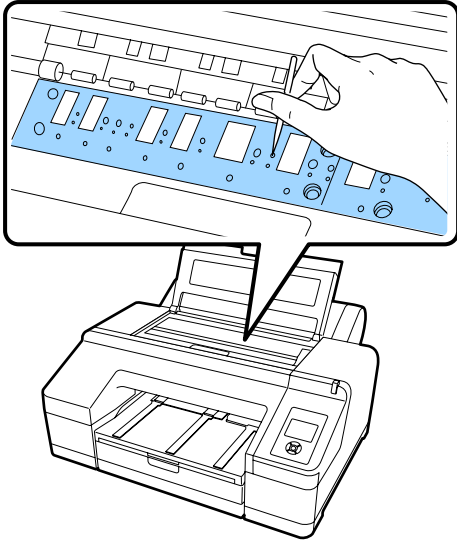













- 5 When you have finished cleaning, close the printer cover.

# Problem Solver

## What to do When a Message is Displayed

If an error occurs with the printer (it is not working properly), the large alert lamp and/or control panel light lights and a message is displayed on the screen informing you of the problem.

The messages displayed are described in the following section. If you encounter an error message, refer to the solutions listed here and perform the necessary steps to fix the problem.

Error messages	What to do
Ink Cartridge Expended Replace ink cartridge.	Replace the ink cartridge with a new one.  <a href="#">"Replacing Ink Cartridges" on page 130</a>
Ink Cartridge Alert Please use genuine Epson ink cartridges.	Replace the ink cartridge with a genuine Epson ink cartridge that can be used with this printer.  <a href="#">"Options and Consumable Products" on page 161</a>  <a href="#">"Replacing Ink Cartridges" on page 130</a>
Ink Cartridge Alert Non-genuine cartridge! Quality of non-genuine ink may vary.  Non-genuine cartridge may not perform at optimum. Continue? Decline Accept	Select <b>Decline</b> to replace the ink cartridge with a genuine Epson ink cartridge. Selecting <b>Accept</b> may void Epson's warranty.  <a href="#">"Options and Consumable Products" on page 161</a>  <a href="#">"Replacing Ink Cartridges" on page 130</a>
Ink Cartridge Error Replace ink cartridge(s).	<input type="checkbox"/> Remove the ink cartridge and reinstall it. If this message is displayed after reinstalling the ink cartridge, replace it with a new one (do not reinstall the ink cartridge that caused the error).  <a href="#">"Replacing Ink Cartridges" on page 130</a> <input type="checkbox"/> Condensation may occur in the ink cartridge. Leave it at room temperature for at least four hours before installing the ink cartridge.  <a href="#">"Notes on handling ink cartridges" on page 23</a>
Ink Cartridge Error Please install the correct ink cartridge.	Remove the ink cartridge, and install an ink cartridge that can be used with this printer.  <a href="#">"Options and Consumable Products" on page 161</a>  <a href="#">"Replacing Ink Cartridges" on page 130</a>
No Ink Cartridges Install ink cartridge(s).	Install ink cartridge(s).  <a href="#">"Replacing Ink Cartridges" on page 130</a>
Ink Low	Prepare new ink cartridges for replacement.  <a href="#">"Replacing Ink Cartridges" on page 130</a>
Cutter unit nearing end of service life. Recommend replacing the cutter unit.	Paper cutter may be blunt. Replace the cutter.  <a href="#">"Replacing the Cutter" on page 134</a>











## Problem Solver

Error messages	What to do
Cartridge Cover Open Close right and left cartridge covers.	Close the left and right cartridge covers.  <a href="#">"Replacing Ink Cartridges" on page 130</a>
Cartridge Cover Open Close left cartridge cover.	Close the cartridge cover on the left.  <a href="#">"Replacing Ink Cartridges" on page 130</a>
Cartridge Cover Open Close right cartridge cover.	Close the cartridge cover on the right.  <a href="#">"Replacing Ink Cartridges" on page 130</a>
Paper Load Error Remove paper from rear manual feeder and press the ▼ button.	Refer to the "Cut sheets from the front/rear manual feeder have jammed" section in the chart on the following reference page and remove the jammed paper.  <a href="#">"Feeding or ejecting problems" on page 156</a>
Paper Load Error Remove the rear unit to fix paper jam.	Refer to the "Cut sheets from the paper cassette have jammed while printing" section in the chart on the following reference page and remove the jammed paper.  <a href="#">"Feeding or ejecting problems" on page 156</a>
Paper Load Error Remove paper cassette to fix paper jam.	Refer to the "Cut sheets from the paper cassette have jammed while printing" section in the chart on the following reference page and remove the jammed paper.  <a href="#">"Feeding or ejecting problems" on page 156</a>
Paper Load Error ▲Press the ▲ button and remove the jammed paper.	Refer to the "Cut sheets from the front/rear manual feeder have jammed" section in the chart on the following reference page and remove the jammed paper.  <a href="#">"Feeding or ejecting problems" on page 156</a>
Paper Load Error ⌂Press the ⌂ button and remove the jammed paper.	Refer to the "Cut sheets from the front/rear manual feeder have jammed" section in the chart on the following reference page and remove the jammed paper.  <a href="#">"Feeding or ejecting problems" on page 156</a>
Paper Load Error ⌂Press the ⌂ button and reset roll paper.	Press the ⌂ button to rewind the roll paper, then load it into the printer.  <a href="#">"Loading roll paper" on page 33</a>
Cleaning Error Not enough ink. Continue cleaning? Yes (recommended) No	If you select <b>Yes</b> , the ink cartridge replacement message is displayed. Replace the ink cartridge with a new one to continue cleaning.  <a href="#">"Replacing Ink Cartridges" on page 130</a> If you select <b>No</b> , cleaning is canceled and it returns to a ready status.
Cleaning Error Automatic head cleaning failed. Retry? Yes No	Clogged nozzles could not be cleared even after cleaning. Select <b>Yes</b> to clean again.  <a href="#">"Cleaning the print head" on page 123</a> If the cleaning does not start, cancel printing from the computer, turn off the printer, wait for a while, and then turn it on again. If you select <b>No</b> , cleaning is canceled and it returns to a ready status.
Cleaning Error Not enough empty space in maint box 1. Continue cleaning? Yes (recommended) No	If you select <b>Yes</b> , the Maintenance Box 1 replacement message is displayed. Replace the Maintenance Box with a new one to continue cleaning.  <a href="#">"Replacing Maintenance Box 1" on page 132</a> If you select <b>No</b> , cleaning is canceled and it returns to a ready status.

### Problem Solver



















Error messages	What to do
<p>Ink Too Low To Clean Replace ink cartridge.</p> <p>The cartridge being used can be installed again for printing.</p>	<p>The message displayed when <b>Yes</b> is selected due to a Cleaning Error or Nozzle Clog Detected error. Replace the ink cartridge with a new one.</p> <p><a href="#">☞ "Replacing Ink Cartridges" on page 130</a></p>
<p>Command Error Check driver settings.</p>	<p>Press the <b>II</b> button and select <b>Job Cancel</b> to cancel printing. Then make sure that you have installed the correct printer driver for the printer.</p>
<p>Check And Clean Nozzle This feature is not available now. Print the check pattern in the nozzle check menu.</p>	<p>Press the OK button to clear the message and then execute <b>Print Check Pattern</b> from the <b>Maintenance</b> Menu.</p> <p><a href="#">☞ "Checking for clogged nozzles" on page 123</a></p>
<p>SpectroProofer Error Refer to the manual to find out how to solve the problem. XX</p> <p>(The error number is displayed instead of XX)</p>	<p>Check the error number and handle the problem as follows.</p> <ul style="list-style-type: none"> <li>❑ If error number 01 is displayed Turn off the printer, and then remove the SpectroProofer mounter. Turn on the printer when the cover is correctly installed. <a href="#">☞ SpectroProofer Mounter 17" User's Guide (PDF)</a> <a href="#">☞ SpectroProofer Mounter 17" Setup Guide (booklet)</a> If this message appears on the screen again, contact your dealer or Epson Support.</li> <li>❑ If error number 02 is displayed Turn off the printer, and then remove the SpectroProofer mounter. Remove the SpectroProofer paper guide unit, and then reinstall it correctly. Reinstall the SpectroProofer mounter correctly and then turn on the printer. <a href="#">☞ SpectroProofer Mounter 17" User's Guide (PDF)</a> <a href="#">☞ SpectroProofer Mounter 17" Setup Guide (booklet)</a> If this message appears on the screen again, contact your dealer or Epson Support.</li> <li>❑ Error number 13 or 15 is displayed Turn off the printer, and then remove the SpectroProofer mounter. Remove any foreign objects and packing materials around the backing of the printer. Reinstall the backing correctly. Reinstall the SpectroProofer mounter correctly and then turn on the printer. <a href="#">☞ SpectroProofer Mounter 17" User's Guide (PDF)</a> <a href="#">☞ SpectroProofer Mounter 17" Setup Guide (booklet)</a> Check that there are no problems with the media type or the environment. <a href="#">☞ SpectroProofer Mounter 17" User's Guide (PDF)</a> If this message appears on the screen again, contact your dealer or Epson Support.</li> <li>❑ If error number 80 is displayed Turn off the printer, and then remove the color measurement device and the white calibration tile from the SpectroProofer mounter. Check that the numbers on the color measurement device and the white calibration tile are the same. If they are different, use them with a combination of the same numbers. If the lens in the color measurement device or the white calibration tile is soiled, clean them. Reinstall it correctly, and then turn on the printer. <a href="#">☞ SpectroProofer Mounter 17" User's Guide (PDF)</a> If this message appears on the screen again, contact your dealer or Epson Support.</li> <li>❑ If any other code appears on the screen, note the code and contact your dealer or Epson Support.</li> </ul>
<p>SpectroProofer Error Connect cable of Spectro Proofer then restart printer.</p>	<p>Turn off the printer and connect the SpectroProofer mounter's printer connector cable. Turn on the printer once you are sure the printer connector cable is connected properly.</p> <p><a href="#">☞ SpectroProofer Mounter 17" Setup Guide (booklet)</a></p>

## Problem Solver

Error messages	What to do
<p>Printless Nozzle Check This feature is not available now. Print the check pattern in the nozzle check menu.</p>	<p>Press the OK button to clear the message and then execute <b>Print Check Pattern</b> from the <b>Maintenance</b> Menu.</p> <p> <a href="#">"Checking for clogged nozzles" on page 123</a></p>
<p>No Front Cover Attach front cover then restart printer.</p>	<p>Turn off the printer, then install the front cover. Reinstall it correctly and then turn on the printer. Installing the front cover  <a href="#">"Replacing the Cutter" on page 134</a></p>
<p>SpectroProofer Error Refer to the manual and connect the ILS to SpectroProofer. Turn the printer power off, and then on again.</p>	<p>Turn off the printer, and then remove the color measurement device from the SpectroProofer mounter. Reinstall it correctly, and then turn on the printer.</p> <p> <a href="#">SpectroProofer Mounter 17" Setup Guide (booklet)</a></p>
<p>Paper Skew Load paper properly.</p>	<p>The paper is not loaded straight. Press the  button to release the pressure roller, and then load the paper correctly.</p> <p> <a href="#">"Loading Roll Paper" on page 31</a></p> <p> <a href="#">"Loading Cut Sheets" on page 38</a></p>
<p>Clogged nozzles detected. Cleaning recommended.</p>	<p>Perform Head Cleaning to remove any clogs. This message continues to be displayed until the clogged nozzles have been cleared, but it disappears when a check pattern is printed. Printing is possible while the message is displayed.</p> <p> <a href="#">"Cleaning the print head" on page 124</a></p>
<p>Nozzle Clog Detected Not enough ink. Continue cleaning? Yes (recommended) No</p>	<p>If you select <b>Yes</b>, the ink cartridge replacement message is displayed. Replace the ink cartridge with a new one to continue cleaning.</p> <p> <a href="#">"Replacing Ink Cartridges" on page 130</a></p> <p>If you select <b>No</b>, cleaning is canceled and it returns to a ready status.</p>
<p>Nozzle Clog Detected Not enough empty space in maint box 1. Continue cleaning? Yes (recommended) No</p>	<p>If you select <b>Yes</b>, the Maintenance Box 1 replacement message is displayed. Replace the Maintenance Box with a new one to continue cleaning.</p> <p> <a href="#">"Replacing Maintenance Box 1" on page 132</a></p> <p>If you select <b>No</b>, cleaning is canceled and it returns to a ready status.</p>
<p>Nozzle Clog Detected Refer to the manual to find out how to solve the problem.</p>	<p>The nozzles may not be cleared of all clogs. Repair the printhead. Contact your dealer or Epson Support.</p> <p>There are also the following measures.</p> <ul style="list-style-type: none"> <li><input type="checkbox"/> If you want to try to clear the nozzles of all clogs one more time before doing repairs, perform Powerful Cleaning. This process consumes ink, but it may clear all of the nozzles of clogs.  <a href="#">"Powerful Cleaning" on page 126</a> If the nozzles are not cleared of all clogs despite performing Powerful Cleaning, repair the printhead.</li> <li><input type="checkbox"/> If you feel that clogged nozzles do not affect the quality of printing, you can continue to use the printer in this condition. However, because Auto Cleaning will occur frequently, turn <b>Off</b> the <b>Auto Nozzle Check</b> in the <b>Printer Setup</b> menu.</li> </ul>

















### Problem Solver

Error messages	What to do
<p>Periodic Cleaning To maintain printing quality, perform Periodic Cleaning. (max 28 min.) Press /A-A to execute, or press  to cancel.</p>	<p>If you continue to use the printer as is, the nozzles may become clogged. Perform Periodic Cleaning. Periodic Cleaning takes a maximum of 28 minutes.</p> <p>Pressing the /A-A button starts Periodic Cleaning.</p> <p>You can start a job without performing Periodic Cleaning by pressing the  button. When a job is complete, execute <b>All Nozzles</b> for <b>Powerful Cleaning</b> from the control panel.</p> <p> <a href="#">"Powerful Cleaning" on page 126</a></p> <p>If Cleaning is not performed, a message will be displayed again after 7 days.</p>
<p>Periodic Cleaning has not been performed.</p>	<p>If you continue to use the printer as is, the nozzles may become clogged. Execute <b>All Nozzles</b> for <b>Powerful Cleaning</b> from the control panel.</p> <p> <a href="#">"Powerful Cleaning" on page 126</a></p>
<p>Wrong Support Position Lower the paper eject support.</p>	<p>The paper eject support is raised. Lower the paper eject support.</p>
<p>Wrong Support Position Raise the paper eject support.</p>	<p>The paper eject support is lowered. Raise the paper eject support.</p>
<p>Paper Eject Error Remove paper from printer.</p>	<p>Press the  button to release the pressure roller, and then remove the paper.</p>
<p>Paper Eject Error Press the  button.</p>	<p>Press the  button to rewind the roll paper.</p> <p> <a href="#">"Removing Roll Paper" on page 36</a></p>
<p>No Rear Unit Install the rear unit.</p>	<p>Install the rear unit. For details on how to install the rear unit, refer to the "Cut sheets from the paper cassette have jammed while printing" section that follows.</p> <p> <a href="#">"Feeding or ejecting problems" on page 156</a></p>
<p>F/W Install Error Update failed. Restart the printer.</p>	<p>Turn the printer off, wait for a few minutes, and then turn on the printer again. Update the firmware again.</p> <p>If this message appears on the screen again, contact your dealer or Epson Support.</p>
<p>Borderless Error Load a supported paper size or load paper correctly.</p>	<p>Check the following points.</p> <ul style="list-style-type: none"> <li><input type="checkbox"/> Press the  button to perform <b>Job Cancel</b>, and then eject the paper. Load the correct size of paper. <ul style="list-style-type: none"> <li> <a href="#">"Loading Roll Paper" on page 31</a></li> <li> <a href="#">"Loading Cut Sheets" on page 38</a></li> <li> <a href="#">"Supported Media Sizes for Borderless Printing" on page 74</a></li> </ul> </li> <li><input type="checkbox"/> If the paper is wavy or curled, the printer cannot recognize the paper size correctly. Flatten the paper before loading it in the printer, or use new paper. <ul style="list-style-type: none"> <li> <a href="#">"Loading Cut Sheets" on page 38</a></li> </ul> </li> <li><input type="checkbox"/> Load paper in the correct position. <ul style="list-style-type: none"> <li> <a href="#">"Loading Roll Paper" on page 31</a></li> <li> <a href="#">"Loading Cut Sheets" on page 38</a></li> </ul> </li> <li><input type="checkbox"/> If <b>Paper Size Check</b> is set to <b>Off</b> from the Menu, try setting it to <b>On</b>. <ul style="list-style-type: none"> <li> <a href="#">"Printer Setup Menu" on page 108</a></li> </ul> </li> </ul>



## Problem Solver

Error messages	What to do
<p>Black Ink Error Black ink does not match print job.</p> <p>To cancel printing, press <b>II</b> button.</p> <p>To change black ink to print, press <b>Black / A·A</b> button.</p>	<p>The type of black ink that is set on the printer and in the printer driver is not the same. Press the <b>Black / A·A</b> button to switch to the type of black ink specified in the printer driver and continue printing. It takes approximately 2 to 3 minutes to switch black ink types (from ink replacement until ink charging is complete). Additionally, 2 to 4 ml from the new black ink will be consumed. Do not switch the black ink unless necessary.</p>
<p>Printer Cover Open Please close the cover.</p>	<p>Close the printer cover.</p>
<p>Maint Box 2 Unlocked Lock lever for maintenance box 2.</p>	<p>Lock Maintenance Box 2.</p> <p>The on-screen message reads Maintenance Box 2. However, the product name for this consumable is Borderless Maintenance Box.</p> <p><a href="#">"Replacing Maintenance Box 2" on page 133</a></p>
<p>Not Enough Empty Space Replace the maintenance box 1.</p>	<p>Replace Maintenance Box 1 with a new one.</p> <p>The on-screen message reads Maintenance Box 1. However, the product name for this consumable is Maintenance Box.</p> <p><a href="#">"Replacing Maintenance Box 1" on page 132</a></p>
<p>Maintenance Box Error Replace the maintenance box 1.</p>	<p>Set Maintenance Box 1 again correctly. If the same error occurs, replace Maintenance Box 1 with a new one.</p> <p>The on-screen message reads Maintenance Box 1. However, the product name for this consumable is Maintenance Box.</p> <p><a href="#">"Replacing Maintenance Box 1" on page 132</a></p>
<p>Maintenance Box Error Replace the maintenance box 2.</p>	<p>Set Maintenance Box 2 again correctly. If the same error occurs, replace Maintenance Box 2 with a new one.</p> <p>The on-screen message reads Maintenance Box 2. However, the product name for this consumable is Borderless Maintenance Box.</p> <p><a href="#">"Replacing Maintenance Box 2" on page 133</a></p>
<p>Replace Maint Box 1 At the end of service life. Replace maint box 1.</p>	<p>Replace Maintenance Box 1 with a new one.</p> <p>The on-screen message reads Maintenance Box 1. However, the product name for this consumable is Maintenance Box.</p> <p><a href="#">"Replacing Maintenance Box 1" on page 132</a></p>
<p>Replace Maint Box 2 To continue borderless printing, replace maint box 2.</p>	<p>To perform borderless printing you must replace Maintenance Box 2.</p> <p>The on-screen message reads Maintenance Box 2. However, the product name for this consumable is Borderless Maintenance Box.</p> <p><a href="#">"Replacing Maintenance Box 2" on page 133</a></p>
<p>No Maintenance Box 1 Install Maintenance box 1.</p>	<p>Install Maintenance Box 1 correctly.</p> <p><a href="#">"Replacing Maintenance Box 1" on page 132</a></p>
<p>No Maintenance Box 2 Install Maintenance box 2.</p>	<p>Install Maintenance Box 2 correctly.</p> <p><a href="#">"Replacing Maintenance Box 2" on page 133</a></p>
<p>Maint box near end of service life.</p>	<p>Check to see if free space is running low in Maintenance Box 1 or Maintenance Box 2 by looking at the control panel's screen. After confirming, replace the maintenance box running low on free space with a new one.</p> <p><a href="#">"Replacing Maintenance Box 1 and 2" on page 132</a></p>

## Problem Solver

Error messages	What to do
No Paper Cassette Install paper cassette.	Install paper cassette.  <a href="#">"Loading the Paper Cassette" on page 39</a>
Paper Cut Error Remove uncut paper.	Roll paper is not cut correctly. Press the  button to release the pressure roller and then remove the uncut paper.  <a href="#">"Feeding or ejecting problems" on page 156</a> Replace the cutter if the blade is blunt.  <a href="#">"Replacing the Cutter" on page 134</a>
Paper Size Error Load correct paper size.	The loaded paper width is not supported. Press the  button to release the pressure roller, and then remove the paper. Check the following conditions and load paper with an appropriate width. <input type="checkbox"/> The smallest paper width that can be used in the printer is 8 inches. <input type="checkbox"/> Make sure that A4 size or larger paper is loaded when performing head alignment.  If an error message is displayed even though paper with an appropriate width is loaded, you may be able to print by setting <b>Paper Size Check</b> to <b>Off</b> from the Menu.  <a href="#">"Printer Setup Menu" on page 108</a>
Paper Low	Prepare a new roll paper for replacement.  <a href="#">"Loading and Removing the Roll Paper" on page 30</a>
Paper Setting Error Check the paper source in your driver settings or reload paper correctly.	The paper feed setting in the printer driver and under Paper Type do not match. Check the loaded paper, the Paper Type settings, and the printer driver settings.
Paper Setting Error This paper cannot be loaded from paper cassette. Insert paper less than 0.8 mm thickness from rear manual feeder.	Paper that cannot be printed from the paper cassette has been loaded in the paper cassette. Press the  button and select <b>Job Cancel</b> , then remove the paper from the paper cassette. Print by feeding the paper into the front manual feeder or rear manual feeder, according to the thickness of the paper.  <a href="#">"Epson Special Media Table" on page 163</a>  <a href="#">"Loading Cut Sheets" on page 38</a>
Paper Setting Error Roll paper is loaded. Remove it and change paper source to roll paper.	Pull out the roll paper and select roll paper from the Paper Type menu.  <a href="#">"Loading roll paper" on page 33</a>
Paper Jam Remove paper from printer. Power off and then on.	Refer to the "Roll paper jam", "Cut sheets from the paper cassette have jammed while printing", or "Cut sheets from the front/rear manual feeder have jammed" sections on the reference page that follows and remove the jammed paper.  <a href="#">"Feeding or ejecting problems" on page 156</a>
Paper Out For paper less than 0.8 mm thickness, insert from rear manual feeder. For thicker paper, press  button then insert from front manual feeder.	Load the paper into the rear manual feeder or front manual feeder depending on the thickness of the paper.  <a href="#">"Loading Manually from the Rear" on page 44</a>  <a href="#">"Loading and Ejecting Thick Paper" on page 46</a>

## Problem Solver

Error messages	What to do
Paper Out Load paper in paper cassette.	Confirm that no paper is being printed, then remove the paper cassette and load the paper. <a href="#">☞ "Loading the Paper Cassette" on page 39</a>
Paper Out Press the  button.	Press the  button, then load the roll paper. <a href="#">☞ "Loading Roll Paper" on page 31</a>  If you run out of paper while printing, the remaining data is printed once you load new paper. If you want to print from the beginning on the new paper instead of continuing from where the job was paused, press the  button and select <b>Job Cancel</b> . After that, load new paper and do the print operation again.
Paper Sensor Error Loaded paper or print out has a problem. Refer to manual for details.	If this error is displayed when performing automatic head alignment, check the following items. <ul style="list-style-type: none"> <li><input type="checkbox"/> Did you load paper that is not supported for automatic head alignment? Automatic head alignment cannot be performed with plain paper or thick paper.</li> <li><input type="checkbox"/> Did you load paper that is smaller than A4 size? Load paper that is of A4 size or larger.</li> <li><input type="checkbox"/> Are some print head nozzles clogged? Execute head cleaning. <a href="#">☞ "Cleaning the print head" on page 124</a></li> </ul> <p>If this error is displayed at any other time besides when performing automatic head alignment, make sure that the paper loaded is supported by the printer. The printer cannot print correctly on paper such as tracing paper or transparencies.</p>
Paper Source Error Cut sheet is loaded. Remove it and change paper source to roll paper.	Press the OK button to clear the message, and then remove the cut sheets from the printer and change the source in the Paper Type Menu.
Paper Source Error Roll paper is loaded. Remove it and change paper source to cut sheet.	Press the OK button to clear the message, and then remove the roll paper from the printer and change the source in the Paper Type Menu. When <b>Auto Roll Feeding</b> is set to <b>Off</b> from the Menu, you cannot change the paper type when roll paper is fed. <a href="#">☞ "Removing Roll Paper" on page 36</a>

## When a Maintenance Call/Service Call Occurs

Error messages	What to do
Maintenance Request Replace Part Soon/ Replace Part Now XXXXXXXX	A part used in the printer is nearing the end of its service life. Contact your dealer or Epson Support and tell them the maintenance request code. You cannot clear the maintenance request until the part is replaced. A service call occurs if you continue to use the printer.

**Problem Solver**

<b>Error messages</b>	<b>What to do</b>
<p>Call For Service Code XXXX Power off and then on. If this does not work, note the code and call for service.</p>	<p>A call for service occurs when:</p> <ul style="list-style-type: none"> <li><input type="checkbox"/> The power cable is not connected securely</li> <li><input type="checkbox"/> An error that cannot be cleared occurs</li> </ul> <p>When a call for service has occurred, the printer automatically stops printing. Turn off the printer, disconnect the power cable from the outlet and from the AC inlet on the printer, and then reconnect. Turn on the printer again multiple times.</p> <p>If the same call for service is displayed on the screen, contact your dealer or Epson Support for assistance. Tell them the call for service code is "XXXX".</p>

## Troubleshooting

### You cannot print (because the printer does not work)

#### The printer does not turn on.

- **Is the power cable plugged into the electrical outlet or the printer?**  
Make sure the power cable is securely plugged into the printer.

- **Is there a problem with the power outlet?**  
Make sure your outlet works by connecting the power cable for another electric product.

#### The printer turns off automatically.

- **Is Power Management enabled?**  
To prevent the printer turning off automatically, select **Off**.  
["Preferences" on page 120](#)

#### The printer driver is not installed properly (Windows).

- **Is the icon for this printer displayed in the Devices and Printers/Printer/Printers and Faxes folder?**
  - Yes  
The printer driver is installed. See "The printer is not connected correctly to the computer" on the next page.
  - No  
The printer driver is not installed. Install the printer driver.

- **Does the printer port setting match the printer connection port?**

Check the printer port.

Click the **Port** tab in the printer Properties dialog and check the option selected for **Print to following port(s)**.

- USB:USBxxx (x stands for the port number) for the USB connection
- Network: The correct IP address for the network connection

If it is not indicated, the printer driver is not installed correctly. Delete and reinstall the printer driver.

["Uninstalling Software" on page 28](#)

#### The printer driver is not installed properly (Mac OS X).

- **Is the printer added to the printer list?**  
Click the Apple menu - **System Preferences** - **Printers & Scanners** (or **Print & Fax**).

If the printer name is not displayed, add the printer.

#### The printer is not communicating with the computer.

- **Is the cable plugged in properly?**  
Confirm that the interface cable is securely connected to both the printer port and the computer. Also, make sure the cable is not broken nor bent. If you have a spare cable, try connecting with the spare cable.

- **Does the interface cable specification match the specifications for the computer?**

Make sure the interface cable specifications match the specifications for the printer and the computer.

["System Requirements" on page 178](#)

- **When using a USB hub, is it being used correctly?**

In the USB specification, daisy-chains of up to five USB hubs are possible. However, we recommend that you connect the printer to the first hub connected directly to the computer. Depending on the hub you are using, the operation of the printer may become unstable. If this should occur, plug the USB cable directly into your computer's USB port.

## Problem Solver

- **Is the USB hub recognized correctly?**  
Make sure the USB hub is recognized correctly on the computer. If the computer correctly detects the USB hub, disconnect all USB hubs from the computer and connect the printer directly to the computer USB port. Ask the USB hub manufacturer about USB hub operation.

### You cannot print under the network environment.

- **Are the network settings correct?**  
Ask your network administrator for the network settings.

- **Connect the printer directly to the computer using a USB cable, and then try to print.**  
If you are able to print via USB, there is a problem with network settings. Ask your system administrator, or refer to the manual for your network system. If you cannot print via USB, see the appropriate section in this User's Guide.

### The printer has an error.

- **View the message displayed in the control panel.**  
[🔗 "Control panel" on page 16](#)  
[🔗 "What to do When a Message is Displayed" on page 141](#)

### The printer stops printing.

- **Is the status of print queue Pause? (Windows)**  
If you stop printing or the printer stops printing because of an error, the print queue enters a **Pause** status. You cannot print in this status.  
  
Double-click the printer icon in the **Devices and Printers, Printers, or Printers and Faxes** folder; if printing is paused, open the **Printer** menu and clear the **Pause** check box.

- **Does the current printer status show Printing Paused (Mac OS X)?**  
Open the status dialog for your printer and check whether printing is paused.  
  
(1) Select **System Preferences > Printers & Scanners** (or **Print & Fax**) > **Open Print Queue** > from the **Apple** menu.  
  
(2) Double-click the icon for any printer that is **Paused**.  
  
(3) Click **Resume Printer**.

### Your problem is not listed here.

- **Decide whether the trouble is caused by the printer driver or the application. (Windows)**  
Perform a test print from the printer driver so that you can check that the connection between the printer and computer is correct and the printer driver settings are correct.  
  
(1) Make sure that the printer is turned on and in ready status, and load A4 or larger paper.  
  
(2) Open the **Devices and Printers, Printers, or Printers and Faxes** folder.  
  
(3) Right-click the target printer icon, and select **Properties**.  
  
(4) In the Properties dialog, select the **General** tab and click **Print Test Page**.  
  
After a while the printer starts to print a test page.  
  
 If the test page is printed correctly, the connection between the printer and computer is correct. Go to the next section.  
  
 If the test page is not printed correctly, check the items above again.  
[🔗 "You cannot print \(because the printer does not work\)" on page 150](#)  
  
The "Driver Version" shown on the test page is the version number of the Windows internal driver. This differs from the Epson printer driver version that you installed.

## The printer sounds like it is printing, but nothing prints

### The print head moves, but nothing prints.

- **Confirm the printer operation.**  
Print a nozzle check pattern. Because a nozzle check pattern can be printed without connecting to a computer, you can check the operations and print status for the printer.

 ["Checking for clogged nozzles" on page 123](#)

Check the next section if the nozzle check pattern is not printed correctly.

- **Is the message Motor Self Adjustment displayed on the control panel's screen?**  
The printer adjusts the internal motor. Wait for a while without turning off the printer.

### The nozzle check pattern is not printed correctly.

- **Perform head cleaning.**  
The nozzles may be clogged. Print a nozzle check pattern again after performing head cleaning.

 ["Cleaning the print head" on page 124](#)

- **Has the printer been left unused for a long time?**  
If the printer has not been used for a long time, the nozzles may have dried up and have been clogged.

- **Do you mainly print on roll paper?**  
Dust may have collected on the roll paper's feed slot. Use the dedicated cleaning sheet to clean the roll paper feed slot.

See the following for the cleaning procedure.

 ["Cleaning the roll paper feed slot" on page 138](#)

## The prints are not what you expected

### Print quality is poor, uneven, too light, or too dark.

- **Are the print head nozzles clogged?**  
If the nozzles are clogged, specific nozzles do not fire ink and the print quality declines. Print a nozzle check pattern.

 ["Checking for clogged nozzles" on page 123](#)

- **Was Head Alignment performed?**  
With bidirectional printing, the print head prints while moving left and right. If the print head is misaligned, ruled lines may be misaligned accordingly. If vertical ruled lines are misaligned with bidirectional printing, perform Head Alignment.

 ["Adjusting print misalignments \(Head Alignment\)" on page 126](#)

- **Are you using a genuine Epson ink cartridge?**  
This printer is developed for use with Epson ink cartridges. If you use non-Epson ink cartridges, printouts may be faint, or the color of the printed image may be changed because the remaining ink level is not correctly detected. Be sure to use the correct ink cartridge.

- **Are you using an old ink cartridge?**  
The print quality declines when an old ink cartridge is used. Replace the old ink cartridge with a new one. We recommend using all the ink in the cartridge before the expiry date printed on the package (within six months of installation).

- **Have the ink cartridges been shaken?**  
The ink cartridges for this printer contain pigment inks. Shake the cartridges thoroughly before installing them in the printer.

 ["Replacing Ink Cartridges" on page 130](#)

- **Are the Media Type settings correct?**  
Print quality is affected if the **Media Type** you have selected in the Printer Settings screen (Windows) or Print screen (Mac OS X) in the printer driver does not match with the paper that is loaded in the printer. Be sure to match the media type setting with the paper that is loaded in the printer.



## Problem Solver

- **Did you select a low quality mode (such as Speed) as the Print Quality?**  
The print quality may decline when you select **Speed** for **Print Quality** or make **Quality Options** settings that assign priority to speed from the printer driver. If you want to improve your print quality, select a setting that assigns priority to quality.

- **Is color management enabled?**  
Enable color management.  
 ["Color Management Printing" on page 98](#)

- **Have you compared the printing result with the image on the display monitor?**  
Since monitors and printers produce colors differently, printed colors will not always match on-screen colors perfectly.

- **Did you open the printer cover while printing?**  
If the printer cover is opened while printing, the print head stops suddenly causing unevenness in the color. Do not open the printer cover while printing.

- **Is Ink Low displayed in the control panel?**  
The print quality may decline when the ink is low. We recommend replacing the ink cartridge with a new one. If there is a difference in color after replacing the ink cartridge, try performing head cleaning a few times.

- **Are you doing Hiigh Speed on commercially available paper?**  
If you have selected Custom Paper from **Paper Type** and the colors are uneven in your printouts, try the following.
  - If you have not registered settings for the commercially available paper  
See the following to register the settings.  
 ["Before Printing on Commercially Available Paper" on page 174](#)
  - If you have registered settings for the commercially available paper  
Perform uni-directional printing. Follow the steps below to clear the checkbox for **High Speed** in the printer driver.  
Windows: On the Main screen, select **Quality Options** from **Print Quality**.  
Mac OS X: Select **Print Settings** from the list, and then select the **Advanced Color Settings** tab.

## The color is not exactly the same as another printer.

- **Colors vary depending on the printer type due to each printer's characteristics.**  
Because inks, printer drivers, and printer profiles are developed for each printer model, the colors printed by different printer models are not exactly the same.  
  
You can achieve similar colors with the same color adjustment method or the same gamma setting by using the printer driver.  
  
 ["Color Management Printing" on page 98](#)  
  
To match the color precisely, use the color measurement device to perform color management.

## The print is not positioned properly on the media.

- **Have you specified the print area?**  
Check the print area in the settings of the application and the printer.
- **Is the correct option selected for Page Size?**  
If the option selected for **Page Size** or **Paper Size** in the printer driver does not match the paper loaded in the printer, the print may not be in the correct position or some of the data may be printed off the paper. In this case, check the print settings.
- **Is the paper skewed?**  
If **Off** is selected for **Paper Skew Check** in the Printer Setup menu, printing will continue even if the paper is skewed, resulting in data being printed off the paper. Set **On** for **Paper Skew Check** in the Printer Setup menu.  
  
 ["Printer Setup" on page 117](#)

- **Does the print data fit within the paper width?**  
Although under normal circumstances printing stops if the print image is wider than the paper, the printer may print outside the bounds of the paper when **Off** is selected for **Paper Size Check** in the Printer Setup menu. Change the setting to **On**.  
  
 ["Printer Setup Menu" on page 108](#)

## Problem Solver

### ■ Is the roll paper margin set to 15 mm or 35 mm?

If the value selected for **Roll Paper Margin** in the Paper menu is wider than the margins selected in the application, priority will be given to the value selected for **Roll Paper Margin**. For example, if 15 mm is selected for the left and right margins in the printer's Paper menu and the document fills the page, the 15 mm at the left and right sides of the page will not be printed.

 ["Printable area" on page 52](#)

### ■ Is the print head scuffing the printed surface?

If the surface of the paper is scuffed, select a **Platen Gap** option between **Wide** and **Widest**.

 ["Custom Paper" on page 115](#)

 ["Printer Setup" on page 117](#)

### ■ Is the print head scuffing the edge of the paper?

In the Paper menu, select **Top35mm/Bottom15mm** as the **Roll Paper Setup - Roll Paper Margin** option.

 ["Paper" on page 113](#)

## Vertical ruled lines are misaligned.

### ■ Is the print head misaligned? (in bidirectional printing)

With bidirectional printing, the print head prints while moving left and right. If the print head is misaligned, ruled lines may be misaligned accordingly. If vertical ruled lines are misaligned with bidirectional printing, perform Head Alignment.

 ["Adjusting print misalignments \(Head Alignment\)" on page 126](#)

### ■ Widen the bottom margin

Depending on the paper usage, storage conditions, and the content of the print data, the bottom edge may be scuffed when printing. In this situation it is best to create your data with a wider bottom margin.

### ■ Does the interior of the printer need cleaning?

The rollers may need cleaning. Clean the rollers by feeding and ejecting paper.

 ["Cleaning the inside" on page 137](#)

## The printed surface is scuffed or soiled.

### ■ Is the paper too thick or too thin?

Check that the paper specifications are compatible with this printer.

 ["Supported Media" on page 163](#)

For information about the media types and appropriate settings for printing on paper from other manufacturers or when using RIP software, see the documentation supplied with the paper, or contact the dealer of the paper or the manufacturer of the RIP.

### ■ Is the paper creased or folded?

Do not use old paper or paper with folds in it. Always use new paper.

### ■ Is the paper wavy or curled?

If the paper becomes wavy or curled due to changes in temperature or humidity, the paper may be scuffed.

Check the following points.

- Insert the paper just before printing.
- Do not use wavy or curled paper.  
For roll paper, cut off any parts that are wavy or curled, and then load the paper again.  
For cut sheets, use new paper.

## The paper is creased.

### ■ Are you using the printer at normal room temperature?

Epson special media should be used at normal room temperature (temperature: 15 to 25°C, humidity: 40 to 60%). For information about paper such as thin paper from other manufacturers that requires special handling, see the documentation supplied with the paper.

### ■ When using non-Epson special media, have you made the paper configuration?

When using non-Epson special media, configure the paper characteristics (custom paper) before printing.

 ["Before Printing on Commercially Available Paper" on page 174](#)

## Problem Solver

**The reverse side of the printed paper is soiled.**

■ **Select On for Paper Size Check in the Printer Setup menu.**

Although printing normally stops if the print image is wider than the paper, when **Off** is selected for **Paper Size Check** in the Printer Setup menu, the printer may print outside the bounds of the paper, getting ink on the inside of the printer in the process. This can be prevented by changing the setting to **On**.

 ["Printer Setup" on page 117](#)

 ["Cleaning the inside" on page 137](#)

■ **Is ink dry on the printed surface?**

Depending on the printing density and media type, the ink may take a while to dry. Do not stack the paper until the printed surface is dry.

Also, if you set the **Drying Time per Print Head Pass** in **Paper Configuration** from the printer driver, you can stop the operation after printing (ejecting and cutting paper) and wait until the ink is dry. See the printer driver help for more details on the Paper Configuration dialog box.

**Too much ink is fired.**

■ **Are the Media Type settings correct?**

Make sure that the printer driver's **Media Type** settings match the paper that you are using. The amount of ink to be fired is controlled according to the media type. If the settings do not match the paper loaded, too much ink may be fired.

■ **Is the Color Density setting correct?**

Lower the density of the ink in the **Paper Configuration** dialog box from the printer driver. The printer may be firing too much ink for some paper. See the printer driver help for more details on the Paper Configuration dialog box.

■ **Are you printing on paper that does not dry easily?**

If too much ink is used when printing on paper that does not dry easily, you may get better results by choosing a lower print density in the **Paper Configuration** dialog box.

**Margins appear in borderless printing.**

■ **Are the settings for the print data in the application correct?**

Make sure that the paper settings in the application are correct as well as in the printer driver.

 ["Borderless Printing" on page 73](#)

■ **Are the paper settings correct?**

Make sure that the paper settings of the printer match the paper that you are using.

■ **Have you changed the amount of enlargement?**

Adjust the amount of enlargement for borderless printing. Margins may appear if you set the amount of enlargement to **Min**.

 ["Borderless Printing" on page 73](#)

■ **Is the paper stored correctly?**

The paper may expand or contract if it is not stored correctly so that margins appear even when borderless is set. See the documentation supplied with the paper for more information on the storage method.

■ **Are you using paper that supports borderless printing?**

Paper that does not support borderless printing may expand or contract while printing so that margins appear even when borderless is set. We recommend using paper that is designed to support borderless printing.

■ **Try adjusting the cutter.**

When there are margins on the top and bottom of the roll paper while performing borderless printing, try performing **Adjust Cut Position**. It may reduce the margins.

 ["Maintenance" on page 111](#)

## Problem Solver

## Feeding or ejecting problems

### Unable to feed or eject paper.

■ **Is the paper loaded in the correct position?**

See the following for the correct paper loading positions.

 ["Loading and Removing the Roll Paper" on page 30](#)

 ["Loading Cut Sheets" on page 38](#)

If the paper is loaded correctly, check the condition of the paper that you are using.

■ **Is the paper loaded in the correct direction?**

Load cut sheets vertically. If they are not loaded in the correct direction, the paper may not be recognized and an error may occur.

 ["Loading Cut Sheets" on page 38](#)

■ **Are you trying to load cut sheets from the rear manual feeder or the front manual feeder when roll paper has already been loaded?**

Load cut sheets after selecting **Cut Sheet** from the **Paper Type** menu.

When **Auto Roll Feeding** is set to **Off**, remove the roll paper first, and then load cut sheets.

 ["Loading Manually from the Rear" on page 44](#)

 ["Loading and Ejecting Thick Paper" on page 46](#)

■ **Is the paper creased or folded?**

Do not use old paper or paper with folds in it. Always use new paper.

■ **Is the paper damp?**

Do not use paper that is damp. Also, Epson special media should be left in the bag until you intend to use it. If it is left out for a long time, the paper curls up and gets damp so that it does not feed properly.

■ **Is the paper wavy or curled?**

If the paper becomes wavy or curled due to changes in temperature or humidity, the printer may not be able to recognize the paper size correctly.

Check the following points.

- Insert the paper just before printing.
- Do not use wavy or curled paper. For roll paper, cut off any parts that are wavy or curled, and then load the paper again. For cut sheets, use new paper.

■ **Is the paper too thick or too thin?**

Check that the paper specifications are compatible with this printer. For information about the media types and appropriate settings for printing on paper from other manufacturers or when using RIP software, see the documentation supplied with the paper, or contact the dealer of the paper or the manufacturer of the RIP.

■ **Are you using the printer at normal room temperature?**

Epson special media should be used at normal room temperature (temperature: 15 to 25°C, humidity: 40 to 60%).

■ **Is paper jammed in the printer?**

Open the printer cover of the printer and check that there are no paper jams or foreign objects in the printer. If paper is jammed, see "Paper jams" below and clear the jammed paper.

■ **Is the paper suction too strong?**

If you continue to have problems with ejected paper, try lowering the Paper Suction (the amount of suction used to keep the paper on the paper feed path).

 ["Custom Paper" on page 115](#)

### Unable to rewind the roll paper.

■ **Is the printer in standby status after cutting?**

The roll paper is automatically rewound if you press the  button when the printer is in standby status after cutting the roll paper.

### Roll paper jam

To remove jammed paper, follow the steps below:

**Problem Solver**

- 1** Open the roll paper cover and cut off the paper at the slot of the roll paper feeder using a cutter sold at a store.

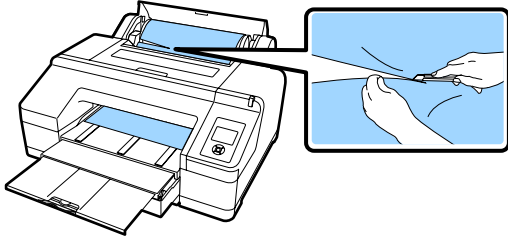

- 2** Hold both ends of the spindle and lift up from the spindle holder.

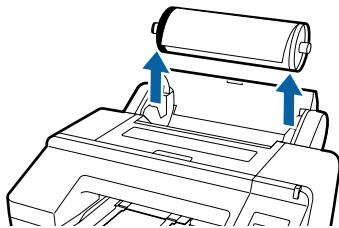

- 3** Remove the jammed paper from the roll paper feeder/front manual feeder.

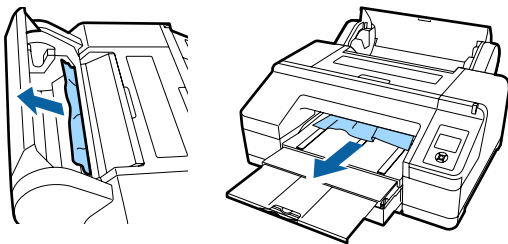

- 4** Open the printer cover and remove any other jammed paper if necessary.

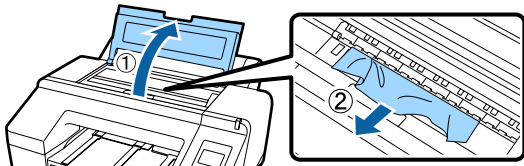

Turn off the printer, and then turn it back on.

Reload the paper and restart printing.

 [“Loading roll paper” on page 33](#)

**Cut sheets from the paper cassette have jammed while printing.**

To remove jammed paper, follow the steps below:

- 1** Remove the output tray and the paper cassette.

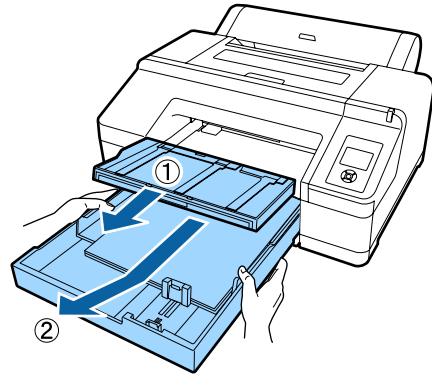

- 2** Remove the jammed paper from where the cassette was inserted.

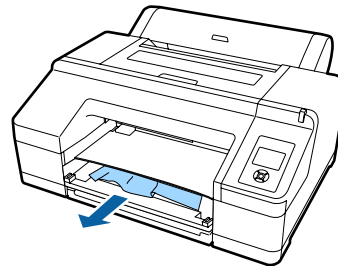

- 3** If paper is jammed in the rear, remove the rear unit by pulling it towards you with the knob moved to the inside as shown in the figure, and then remove the jammed paper.

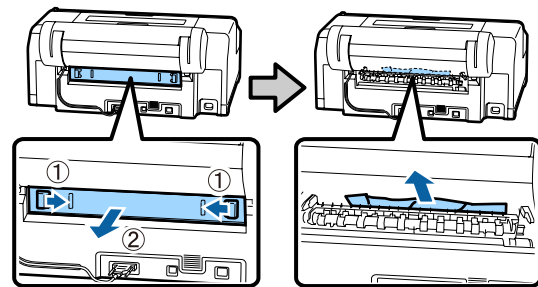

- 4** Replace the rear unit.

With the rear unit's knob moved to the inside, push it into the printer firmly until you hear it click into place.

Turn off the printer, and then turn it back on.

Reload the paper and restart printing.

 [“Loading the Paper Cassette” on page 39](#)

Problem Solver

**Cut sheets from the front/rear manual feeder have jammed.**

To remove jammed paper, follow the steps below:

- 1 Remove the jammed paper from the rear/front manual feeder.

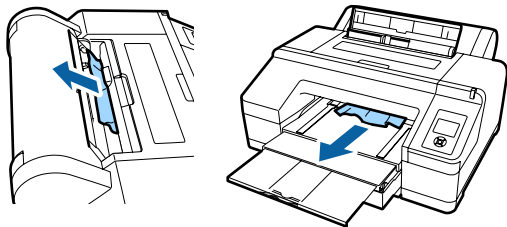

- 2 Open the printer cover and remove any other jammed paper if necessary.

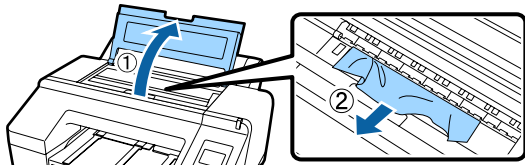

Turn off the printer, and then turn it back on.

Reload the paper and restart printing.

[“Loading Manually from the Rear” on page 44](#)

[“Loading and Ejecting Thick Paper” on page 46](#)

**Others**

**Cannot remove the paper cassette.**

- **You may have turned off the printer while an error had occurred.**  
Remove the paper cassette after turning the printer back on and waiting for a few minutes.

**The control panel display keeps turning off.**

- **Is the printer in sleep mode?**  
Sleep mode is exited if a print job is received or the button on the control panel is pressed. The delay can be changed from the Preferences menu.  
[“Preferences” on page 120](#)

**The printer is connected, but the firmware cannot be updated.**

- **Is the printer in sleep mode?**  
Update the firmware after sleep mode has been completely exited.  
There are the following two methods to completely recover from sleep mode.
  - ❑ From the printer  
Do an operation that entails a hardware operation or press the button after restarting the screen to have the printer recover from sleep mode.
  - ❑ From EpsonNet Config (Web)  
Start a web browser and input the printer's IP address in the address bar.  
If it takes a long time to start EpsonNet Config (Web), wait at least 30 seconds and then input the printer's IP address in the address bar again.

**Color ink runs out quickly even when printing in the Black&White mode or when printing black data.**

- **Color ink is consumed during the head cleaning process.**  
If you select **Check And Clean Nozzle, All Nozzles**, or **Powerful Cleaning**, inks of all colors will be consumed. (This is true even if you are currently printing in black and white.)  
[“Cleaning the print head” on page 124](#)

**The paper is not cut cleanly.**

- **Replace the cutter.**  
If the paper is not cut cleanly, replace the cutter.  
[“Replacing the Cutter” on page 134](#)

**A light is visible inside the printer.**

- **This is not a failure.**  
The light is a light inside the printer.

**Head cleaning is performed automatically**

- The printer may automatically perform head cleaning to ensure print quality.



## Problem Solver

## When an error occurs during color measurement (when using the SpectroProofer mounter), the colors do not match even after performing color calibration

### ■ Are the temperature and humidity within the range specified for the printer (during operation) and paper?

If the color measurement chart is printed outside the recommended environmental conditions, the correct color measurement is not acquired. See the manuals supplied with the printer and paper for the recommended environmental conditions.

Recommended environment for the printer  ["Specifications Table" on page 179](#)

### ■ Do the RIP or application print settings differ from the actual print conditions?

Printing cannot be performed correctly if the paper type or black ink type differ from the RIP or application settings. Check the the paper type loaded in the printer and the black ink type settings are correct.

### ■ Was the color measurement chart printed with clogged nozzles?

Check that there is no visible banding (horizontal lines at regular intervals) in the color measurement chart. If a color measurement chart is printed with clogged nozzles, the correct color measurement result cannot be acquired. If there are clogged nozzles, perform head cleaning, and then print the color measurement chart again.

 ["Cleaning the print head" on page 123](#)

### ■ Are there stains or scratches on the color measurement chart, or does ink peel off?



If there are stains or scratches on the color measurement chart, or if ink peels off, the correct color measurement result cannot be acquired. Reprint the color measurement chart.

### ■ Is the color measurement chart sufficiently dry?

If the ink has not dried sufficiently, the correct color measurement result cannot be acquired. When using commercially available paper, if the drying time is not increased beyond the standard time, ink will not be dried sufficiently. Set a longer drying time in the RIP or application you are using. See the manual supplied with the RIP or application for more information in setting the drying time. See the manual supplied with the paper for more information on the drying condition.

### ■ Was custom paper information registered?

When performing calibration for commercially available paper, use one of the following methods to register custom paper information. If the paper has not been registered, you cannot select it from the Epson Color Calibration Utility paper types.

- Register the paper in the printer driver.  
Windows  ["Adding a Paper Type" on page 58](#)  
Mac OS X  ["Saving to Presets" on page 63](#)
- Register the paper in the printer.  
In **Select Reference Paper**, select anything except for **No Paper Selected**. If you select **No Paper Selected**, an error is generated in Epson Color Calibration Utility and calibration cannot be done.  
 ["Custom Paper" on page 115](#)

### ■ Is any external light (direct sunlight) entering the printer when performing color measurement?

If any external light enters the printer, the correct color measurement result cannot be acquired. Prevent external light from entering the printer.

## The printer turned off due to a power cut

### ■ Turn off the printer, and then turn it back on.

When the printer is not turned off normally, the print head may not be capped correctly. If the print head is left uncapped for a long time, the print quality may decline.

When you turn on the printer, capping is performed automatically after a few minutes.

Also, if the printer is turned off during calibration, data transmission and writing adjustment values may not be performed correctly. Turn on the printer, and then check **Calibration Date** from the Printer Status menu. When the date is initialized, the adjustment values are also initialized.

Exit Epson Color Calibration Utility, and then restart. The adjustment values are automatically restored.

 ["Printer Status" on page 118](#)

 [Epson Color Calibration Utility Operator's Guide \(PDF\)](#)

## Forgot password set to protect the network

### ■ Contact your dealer or Epson Support.



# Appendix

## Options and Consumable Products

The following options and consumable products are available for use with your printer. (As of August, 2016)

For the latest information, see the Epson Web site.

Name		Product Code		Explanation
Epson special media		See the following section for media. <a href="#">“Epson Special Media Table” on page 163</a>		
Ink cartridges	Color	SC-P5000/SC-P5070	SC-P5080	Epson recommends the use of genuine Epson ink cartridges. Epson cannot guarantee the quality or reliability of non-genuine ink. The use of non-genuine ink may cause damage that is not covered by Epson's warranties, and under certain circumstances, may cause erratic printer behavior. Information about non-genuine ink levels may not be displayed, and use of non-genuine ink is recorded for possible use in service support.  <a href="#">“Replacing Ink Cartridges” on page 130</a>
	Photo Black	T9131	T9151	
	Cyan	T9132	T9152	
	Vivid Magenta	T9133	T9153	
	Yellow	T9134	T9154	
	Light Cyan	T9135	T9155	
	Vivid Light Magenta	T9136	T9156	
	Light Black	T9137	T9157	
	Matte Black	T9138	T9158	
	Light Light Black	T9139	T9159	
	Orange	T913A	T915A	
	Green	T913B	T915B	
	Violet	T913D	T915D	
Maintenance Box (Maintenance Box 1)	T6190		Replacement Maintenance Box for Maintenance Box 1, which is at the end of its service life.  <a href="#">“Replacing Maintenance Box 1” on page 132</a>	
Borderless Maintenance Box (Maintenance Box 2)	T6191		Replacement Maintenance Box for Maintenance Box 2, which is at the end of its service life.  <a href="#">“Replacing Maintenance Box 2” on page 133</a>	

**Appendix**

Name	Product Code	Explanation
Auto Cutter Spare Blade	C12C815351	<p>See the following section to replace the cutter.</p> <p><a href="#">↗ "Replacing the Cutter" on page 134</a></p>
2/3" Dual Roll Feed Spindle	C12C811251	<p>Same as the spindle supplied with the printer.</p>
Cleaning Sheet	C13S400045	<p>This is a sheet that removes dust from the roll paper feed slot.</p> <p><a href="#">↗ "Cleaning the roll paper feed slot" on page 138</a></p>
Roll Paper Belt	C12C890121	
SpectroProofer Mounter 17"	C12C890631	<p>When the optional ILS30EP is installed and attached to the printer, color measurement is automatically performed for printed material. See the manual supplied with the mounter for more information on installing.</p> <p>You need a commercially available software RIP to use the mounter.</p>
ILS30EP	C12C932021	<p>Colorimeter installed on the mounter. See the manual supplied with the colorimeter for more information on installing on the mounter.</p>

## Appendix

# Supported Media

The following types of paper can be used in the printer. (As of May, 2016)

We recommend you use the following Epson special media for high-quality printing results.

**Note:**

*For information about the media types and appropriate settings for printing on paper other than Epson special media, or when using raster image processing (RIP) software, see the documentation supplied with the paper, or contact the dealer of the paper or the manufacturer of the RIP.*

## Epson Special Media Table

The following provides the meaning of the table titles for supported paper sizes.

Title	Explanation
Size	This is the size of the paper that is available. For roll paper, this is indicated by the width of the roll.
Paper Thickness	This is the thickness of the paper.
Roll core size	This is the size of the core of the roll of paper.
Number of sheets	This is the maximum number of cut sheets of paper that can be loaded in the paper cassette. -: Paper cassette cannot be used
Borderless	This is the capability of borderless printing. ✓: Recommended paper, -: Unavailable paper
Types of ink	These are the abbreviation for the types of black in that the paper supports. PK: Photo Black/MK: Matte Black
Calibration	Describes whether or not Epson Color Calibration Utility is available. ✓: Available, -: Unavailable
Mounter	Describes whether or not the optional SpectroProofer mounter is available. ✓: Available, -: Unavailable

## Roll Paper

### **Premium Glossy Photo Paper (250)**

Printer driver settings

Photo Paper - Premium Glossy Photo Paper (250)

**Appendix**

ICC profile

(LLK ink set) SC-P5000\_Series\_LLK PremiumGlossyPhotoPaper250.icc

(V ink set) SC-P5000\_Series\_V PremiumGlossyPhotoPaper250.icc

Supported paper sizes

Size	Paper Thickness	Roll core size	Borderless	Types of ink	Calibration	Mounter
406 mm/16 inches	0.27 mm	3 inches	✓	PK	✓	✓

**Premium Semigloss Photo Paper (250)**

Printer driver settings

Photo Paper - Premium Semigloss Photo Paper (250)

ICC profile

(LLK ink set) SC-P5000\_Series\_LLK PremiumSemiglossPhotoPaper250.icc

(V ink set) SC-P5000\_Series\_V PremiumSemiglossPhotoPaper250.icc

Supported paper sizes

Size	Paper Thickness	Roll core size	Borderless	Types of ink	Calibration	Mounter
406 mm/16 inches	0.27 mm	3 inches	✓	PK	✓	✓

**Premium Luster Photo Paper (260)**

Printer driver settings

Photo Paper - Premium Luster Photo Paper (260)

ICC profile

(LLK ink set) SC-P5000\_Series\_LLK PremiumLusterPhotoPaper260.icc

(V ink set) SC-P5000\_Series\_V PremiumLusterPhotoPaper260.icc

Supported paper sizes

Size	Paper Thickness	Roll core size	Borderless	Types of ink	Calibration	Mounter
254 mm/10 inches	0.27 mm	3 inches	✓	PK	-	✓
300 mm/11.8 inches					✓	
406 mm/16 inches					✓	

**Appendix**

**Premium Semimatte Photo Paper (260)**

Printer driver settings

Photo Paper - Premium Semimatte Photo Paper (260)

ICC profile

(LLK ink set) SC-P5000\_Series\_LLK PremiumSemimattePhotoPaper260.icc

(V ink set) SC-P5000\_Series\_V PremiumSemimattePhotoPaper260.icc

Supported paper sizes

Size	Paper Thickness	Roll core size	Borderless	Types of ink	Calibration	Mounter
406 mm/16 inches	0.27 mm	3 inches	✓	PK	✓	✓

**Premium Glossy Photo Paper (170)**

Printer driver settings

Photo Paper - Premium Glossy Photo Paper (170)

ICC profile

(LLK ink set) SC-P5000\_Series\_LLK PremiumGlossyPhotoPaper170.icc

(V ink set) SC-P5000\_Series\_V PremiumGlossyPhotoPaper170.icc

Supported paper sizes

Size	Paper Thickness	Roll core size	Borderless	Types of ink	Calibration	Mounter
420 mm/A2	0.18 mm	2 inches	✓*	PK	✓	✓

\* The spacer for borderless printing provided with the product must be installed.

 [“Removing and installing the spacer” on page 32](#)

**Premium Semigloss Photo Paper (170)**

Printer driver settings

Photo Paper - Premium Semigloss Photo Paper (170)

ICC profile

(LLK ink set) SC-P5000\_Series\_LLK PremiumSemiglossPhotoPaper170.icc

(V ink set) SC-P5000\_Series\_V PremiumSemiglossPhotoPaper170.icc

**Appendix**

Supported paper sizes

Size	Paper Thickness	Roll core size	Borderless	Types of ink	Calibration	Mounter
420 mm/A2	0.18 mm	2 inches	✓*	PK	✓	✓

\* The spacer for borderless printing provided with the product must be installed.

 [“Removing and installing the spacer” on page 32](#)

**Photo Paper Gloss 250**

Printer driver settings

Photo Paper - Photo Paper Gloss 250

ICC profile

(LLK ink set) SC-P5000\_Series\_LLK PhotoPaperGloss250.icc

(V ink set) SC-P5000\_Series\_V PhotoPaperGloss250.icc

Supported paper sizes

Size	Paper Thickness	Roll core size	Borderless	Types of ink	Calibration	Mounter
432 mm/17 inches	0.25 mm	3 inches	✓	PK	✓	✓

**Epson Proofing Paper White Semimatte**

Printer driver settings

Proofing Paper - Epson Proofing Paper White Semimatte

ICC profile

(LLK ink set) SC-P5000\_Series\_LLK EpsonProofingPaperWhiteSemimatte.icc

(V ink set) SC-P5000\_Series\_V EpsonProofingPaperWhiteSemimatte.icc

Supported paper sizes

Size	Paper Thickness	Roll core size	Borderless	Types of ink	Calibration	Mounter
329 mm/13 inches	0.25 mm	3 inches	✓*	PK	✓	✓
432 mm/17 inches						

\* You can specify and perform borderless printing; however, margins may appear or the print quality may decline due to the paper expanding or contracting.

**Appendix**

**Epson Proofing Paper Commercial**

- Printer driver settings

Proofing Paper - Epson Proofing Paper Commercial

- ICC profile

(LLK ink set) SC-P5000\_Series\_LLK EpsonProofingPaperCommercial.icc

(V ink set) SC-P5000\_Series\_V EpsonProofingPaperCommercial.icc

- Supported paper sizes

Size	Paper Thickness	Roll core size	Borderless	Types of ink	Calibration	Mounter
329 mm/13 inches	0.20 mm	3 inches	✓*	PK	✓	✓
432 mm/17 inches						

\* You can specify and perform borderless printing; however, margins may appear or the print quality may decline due to the paper expanding or contracting.

**Singleweight Matte Paper**

- Printer driver settings

Matte Paper - Singleweight Matte Paper/Singleweight Matte Paper (line drawing)

- ICC profile

SC-P5000\_Series Standard.icc

- Supported paper sizes

Size	Paper Thickness	Roll core size	Borderless	Types of ink	Calibration	Mounter
432 mm/17 inches	0.15 mm	2 inches	✓	MK	✓	-

**Enhanced Matte Paper**

- Printer driver settings

Matte Paper - Enhanced Matte Paper

- ICC profile

(LLK ink set) SC-P5000\_Series\_LLK EnhancedMattePaper\_MK.icc

(V ink set) SC-P5000\_Series\_V EnhancedMattePaper\_MK.icc

- Supported paper sizes

## Appendix

Size	Paper Thickness	Roll core size	Borderless	Types of ink	Calibration	Mounter
432 mm/17 inches	0.25 mm	3 inches	✓*	MK	✓	✓

\* You can specify and perform borderless printing; however, margins may appear or the print quality may decline due to the paper expanding or contracting.

### **UltraSmooth Fine Art Paper**

#### Printer driver settings

Fine Art Paper - UltraSmooth Fine Art Paper

#### ICC profile

(LLK ink set, when MK is selected) SC-P5000\_Series\_LLK UltraSmoothFineArtPaper\_MK.icc

(LLK ink set, when PK is selected) SC-P5000\_Series\_LLK UltraSmoothFineArtPaper\_PK.icc

(V ink set, when MK is selected) SC-P5000\_Series\_V UltraSmoothFineArtPaper\_MK.icc

(V ink set, when PK is selected) SC-P5000\_Series\_V UltraSmoothFineArtPaper\_PK.icc

#### Supported paper sizes

Size	Paper Thickness	Roll core size	Borderless	Types of ink	Calibration	Mounter
432 mm/17 inches	0.34 mm	3 inches	✓*	PK/MK	✓	✓

\* You can specify and perform borderless printing; however, margins may appear or the print quality may decline due to the paper expanding or contracting.

## Cut sheet

### **Premium Glossy Photo Paper**

#### Printer driver settings

Photo Paper - Premium Glossy Photo Paper

#### ICC profile

(LLK ink set) SC-P5000\_Series\_LLK PremiumGlossyPhotoPaper.icc

(V ink set) SC-P5000\_Series\_V PremiumGlossyPhotoPaper.icc

#### Supported paper sizes



**Appendix**

Size	Paper Thickness	Number of sheets	Borderless	Types of ink	Calibration	Mounter
8" x 10"	0.27 mm	100	-	PK	-	✓
A4			✓			
11" x 14"		20	-			
US B (11" x 17")			✓			
A3						
A3+						
A2		25	-		✓	

**Premium Semigloss Photo Paper**

- Printer driver settings

Photo Paper - Premium Semigloss Photo Paper

- ICC profile

(LLK ink set) SC-P5000\_Series\_LLK PremiumSemiglossPhotoPaper.icc

(V ink set) SC-P5000\_Series\_V PremiumSemiglossPhotoPaper.icc

- Supported paper sizes

Size	Paper Thickness	Number of sheets	Borderless	Types of ink	Calibration	Mounter
A4	0.27 mm	100	✓	PK	-	✓
A3					✓	
A3+			-			
A2						

**Premium Luster Photo Paper**

- Printer driver settings

Photo Paper - Premium Luster Photo Paper

- ICC profile

(LLK ink set) SC-P5000\_Series\_LLK PremiumLusterPhotoPaper.icc

(V ink set) SC-P5000\_Series\_V PremiumLusterPhotoPaper.icc

- Supported paper sizes

**Appendix**

Size	Paper Thickness	Number of sheets	Borderless	Types of ink	Calibration	Mounter
A3	0.27 mm	100	✓	PK	✓	✓
A3+			-			
A2			-			

**EPSON Proofing Paper White Semimatte**

Printer driver settings

Proofing Paper - Epson Proofing Paper White Semimatte

ICC profile

(LLK ink set) SC-P5000\_Series\_LLK EpsonProofingPaperWhiteSemimatte.icc

(V ink set) SC-P5000\_Series\_V EpsonProofingPaperWhiteSemimatte.icc

Supported paper sizes

Size	Paper Thickness	Number of sheets	Borderless	Types of ink	Calibration	Mounter
A3+	0.25 mm	100	✓*	PK	✓	✓

\* You can specify and perform borderless printing; however, margins may appear or the print quality may decline due to the paper expanding or contracting.

**Photo Quality Ink Jet Paper**

Printer driver settings

Matte Paper - Photo Quality Ink Jet Paper

ICC profile

SC-P5000\_Series Standard.icc

Supported paper sizes

Size	Paper Thickness	Number of sheets	Borderless	Types of ink	Calibration	Mounter
A4	0.12 mm	100	✓*	MK	-	-
US-B			-			
A3			✓*			
A3+		-				
A2		30	-			

**Appendix**

\* You can specify and perform borderless printing; however, margins may appear or the print quality may decline due to the paper expanding or contracting.

**Archival Matte Paper**

Printer driver settings

Matte Paper - Archival Matte Paper

ICC profile

(LLK ink set) SC-P5000\_Series\_LLK ArchivalMattePaper\_MK.icc

(V ink set) SC-P5000\_Series\_V ArchivalMattePaper\_MK.icc

Supported paper sizes

Size	Paper Thickness	Number of sheets	Borderless	Types of ink	Calibration	Mounter
A4	0.25 mm	100	✓*	MK	-	✓
A3		50			-	
A3+			✓			
A2						

\* You can specify and perform borderless printing; however, margins may appear or the print quality may decline due to the paper expanding or contracting.

**Watercolor Paper - Radiant White**

Printer driver settings

Fine Art Paper - Watercolor Paper - Radiant White

ICC profile

(LLK ink set, when MK is selected) SC-P5000\_Series\_LLK WatercolorPaper-RadiantWhite\_MK.icc

(LLK ink set, when PK is selected) SC-P5000\_Series\_LLK WatercolorPaper-RadiantWhite\_PK.icc

(V ink set, when MK is selected) SC-P5000\_Series\_V WatercolorPaper-RadiantWhite\_MK.icc

(V ink set, when PK is selected) SC-P5000\_Series\_V WatercolorPaper-RadiantWhite\_PK.icc

Supported paper sizes

Size	Paper Thickness	Number of sheets	Borderless	Types of ink	Calibration	Mounter
A3+	0.29 mm	-	✓*1	PK/MK	✓	✓*2

**Appendix**

- \*1 You can specify and perform borderless printing; however, margins may appear or the print quality may decline due to the paper expanding or contracting.
- \*2 Operations are guaranteed (color measurements are not guaranteed).

**UltraSmooth Fine Art Paper**

Printer driver settings

Fine Art Paper - UltraSmooth Fine Art Paper

ICC profile

(LLK ink set, when MK is selected) SC-P5000\_Series\_LLK UltraSmoothFineArtPaper\_MK.icc

(LLK ink set, when PK is selected) SC-P5000\_Series\_LLK UltraSmoothFineArtPaper\_PK.icc

(V ink set, when MK is selected) SC-P5000\_Series\_V UltraSmoothFineArtPaper\_MK.icc

(V ink set, when PK is selected) SC-P5000\_Series\_V UltraSmoothFineArtPaper\_PK.icc

Supported paper sizes

Size	Paper Thickness	Number of sheets	Borderless	Types of ink	Calibration	Mounter
A3+	0.46 mm	-	✓*	PK/MK	✓	✓
A2			-			

- \* You can specify and perform borderless printing; however, margins may appear or the print quality may decline due to the paper expanding or contracting.

**Velvet Fine Art Paper**

Printer driver settings

Fine Art Paper - Velvet Fine Art Paper

ICC profile

(LLK ink set, when MK is selected) SC-P5000\_Series\_LLK VelvetFineArtPaper\_MK.icc

(LLK ink set, when PK is selected) SC-P5000\_Series\_LLK VelvetFineArtPaper\_PK.icc

(V ink set, when MK is selected) SC-P5000\_Series\_V VelvetFineArtPaper\_MK.icc

(V ink set, when PK is selected) SC-P5000\_Series\_V VelvetFineArtPaper\_PK.icc

Supported paper sizes

## Appendix

Size	Paper Thickness	Number of sheets	Borderless	Types of ink	Calibration	Mounter
A4	0.48 mm	-	✓*1	PK/MK	-	✓*2
A3+			-		✓	
A2			-			

\*1 You can specify and perform borderless printing; however, margins may appear or the print quality may decline due to the paper expanding or contracting.

\*2 Operations are guaranteed (color measurements are not guaranteed).

## Supported Commercially Available Paper

When using commercially available paper, make sure you register the paper information.

 [“Before Printing on Commercially Available Paper” on page 174](#)

This printer supports the following paper specifications for non-Epson media.

### Important:

- Do not use paper that is wrinkled, scuffed, torn, or dirty.
- Although plain paper and recycled paper manufactured by other companies can be loaded and fed in the printer as long as they meet the following specifications, Epson cannot guarantee the print quality.
- Although other paper types manufactured by other companies can be loaded in the printer as long as they meet the following specifications, Epson cannot guarantee the paper feeding and print quality.
- When using the SpectroProofer mounter, see the documentation supplied with your software RIP.

### Roll Paper

Roll core size	2 inch and 3 inch
Roll paper outer diameter	2-inch core: 103 mm or less 3-inch core: 150 mm or less
Paper Width	203 mm (8 inches) to 432 mm (17 inches)
Paper Length	2-inch core: 45 m or less 3-inch core: 30.5 m or less
Paper Thickness	0.08 mm to 0.50 mm

### Cut sheet

Paper Width	203 mm (8 inches) to 432 mm (17 inches)
Paper length	254 mm (10 inches) to 610 mm (24 inches)
Paper Thickness	0.08 mm to 1.50 mm (0.8 mm to 1.5 mm for thick paper)

## Appendix

### Supported paper widths for borderless printing (roll paper)

A4/210 mm	A2/420 mm*	10 inch
A3/297 mm	11 inch*	16 inch
Super A3/B/329 mm	17 inch	300 mm/11.8 inch
SuperW A3/329 mm	8 inch*	

\* You can only perform borderless printing when using the borderless printing spacer supplied with the printer and when you have loaded the roll paper with a 2 inch core.

 [“Removing and installing the spacer” on page 32](#)

### Supported paper widths for borderless printing (cut sheets)

A4/210 mm	SuperW A3/329 mm	16 inch
A3/297 mm	17 inch	300 mm/11.8 inch
Super A3/B/329 mm	10 inch	

### When using the Epson Color Calibration Utility

**Even if the specified conditions are met, you cannot use the following paper types.**

- Paper that is thin and soft (plain paper and so on)
- Paper with an uneven print surface
- Paper that is colored or transparent
- Paper on which ink blurs or overflows when printing
- Paper which bends seriously during loading and printing

**When performing color calibration for multiple printers, you can only use cut sheets A3 size or larger.**

For one printer, you can use A3 size or larger roll paper as well as cut sheets.

---

## Before Printing on Commercially Available Paper

**Note:**

- Be sure to check the paper characteristics (such as if the paper is glossy, the material, and the thickness) in the manual provided with the paper or contact the dealer of the paper.
- Test the print quality with this printer before purchasing a large amount of paper.

When using non-Epson media (Custom Paper), make the paper configuration according to the paper characteristics before printing. Printing without making configuring may cause wrinkles, rubbing, uneven colors, and so on.



Make sure you set the following three items.

## Appendix

Select Reference Paper	<p>The optimum settings for using different types of Epson special media have already been registered to this printer.</p> <p>Check the following, and then select the Epson special media type that is closest to the paper you are using.</p> <ul style="list-style-type: none"> <li><input type="checkbox"/> Glossy paper*: <b>Photo Paper</b> or <b>Proofing Paper</b></li> <li><input type="checkbox"/> Thick paper that is not glossy: <b>Matte Paper</b></li> <li><input type="checkbox"/> Thin, soft paper that is not glossy: <b>Plain Paper</b></li> <li><input type="checkbox"/> Cotton paper with an uneven surface: <b>Fine Art Paper</b></li> <li><input type="checkbox"/> Special media such as film, cloth, poster board, and tracing paper: <b>Others</b></li> </ul>
Paper Thickness	<p>Set the thickness of the paper. If you do not know the exact thickness, set <b>Thickness Pattern</b> from the control panel's Paper menu.</p> <p>This allows you to reduce the grainy feeling and scuff marks in print outs, as well as differences in the print position and color.</p>
Paper Feed Adjust A	<p>Optimizes the paper feed when printing. Reduces banding (horizontal stripes) or uneven colors.</p>

\* Check which to select in the manual provided with the paper or contact the dealer of the paper.

Make settings using one of the following three methods.

- Set **Custom Paper** from the control panel's Paper menu.  
You can make paper settings for all items except for the three mentioned above.  
 ["From the printer" on page 176](#)
- Set in EPSON LFP Remote Panel 2 (software supplied)  
You can make the same settings as the control panel's Paper menu from a computer. For details, see the EPSON LFP Remote Panel 2 help.
- Set in the printer driver.  
Make settings from the printer driver, and save to a computer.  
When **Custom Paper** is selected in **Paper Type** from the control panel's Paper menu, the control panel's settings are enabled regardless of the printer driver settings.  
 ["From the printer driver" on page 176](#)

When you have finished making settings, print using the saved settings and check the results. If you are not satisfied with the print results, check the following and set the item according to the problem.

 ["The prints are not what you expected" on page 152](#)

 **Important:**

*If you change one item set in the Paper menu, you need to perform **Paper Feed Adjust A** again.*

## From the printer

Buttons that are used in the following settings

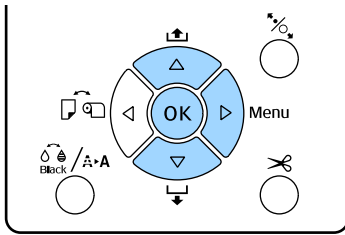

- 1 Press the ► button on the printer's control panel to display the menu.
- 2 Press the ▼/▲ buttons to select **Paper**, and then press the ► button.  
The Paper menu will be displayed.
- 3 Press the ▼/▲ buttons to select **Custom Paper**, and then press the ► button.  
The **Paper Number** menu will be displayed.
- 4 Press the ▼/▲ buttons to select the custom paper number (1 to 10) that you want to save the settings to, and then press the OK button.

A setting items screen is displayed. If you select a number to which settings have already been saved, the setting is overwritten.



Make sure you set the following three items.

- Select Reference Paper**
- Thickness Pattern**
- Paper Feed Adjust A**

See the following for more information on each setup item.

 [“Custom Paper” on page 115](#)

## From the printer driver

- Windows**  
Open the **Main** screen, and then save the settings in **Custom Settings** from **Paper Configuration**.  
 [“Adding a Paper Type” on page 58](#)
- Mac OS X**  
Select **Paper Configuration** from the list, make settings, and then save the settings in Presets.  
 [“Saving to Presets” on page 63](#)



## Notes When Moving or Transporting the Printer

Perform the following operations when moving or transporting the printer.

As shown below, always lift the printer by placing your hands in the indentations on the left and right sides.

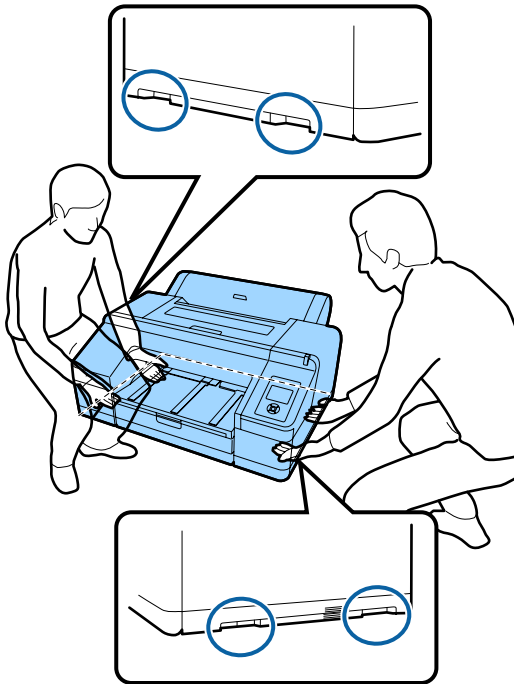

### **!** Important:

- Only hold the required area; otherwise, the printer may be damaged.
- Move and transport the printer with ink cartridges installed. Do not remove the ink cartridges; otherwise, the nozzles may be clogged and make it impossible to print, or ink may leak.

## Before Moving or Transporting

Make the following preparations in advance before moving or transporting the printer.

- Turn off the printer and remove all cables.
- Remove any paper.

- Remove any optional components if they are installed.

## Notes on Transporting

When transporting the printer, repack it using the original box and packing materials to protect it from shock and vibration.

## After Moving or Transporting

After moving or transporting, check if the print head is clogged before use.

 [“Checking for clogged nozzles” on page 123](#)

## Appendix

## System Requirements

The following system requirements are necessary to install and use the software for this printer.

### Windows

Operating system	Windows XP Windows Vista Windows 7 Windows 8 Windows 8.1 Windows 10 Windows Server 2003 Windows Server 2008 Windows Server 2008 R2 Windows Server 2012
CPU	Core 2 Duo 3.05 GHz or higher
Memory	1 GB or more available memory
Available hard disk space	32 GB or more
Interface	Hi-Speed USB-Compatible with the USB 2.0 Specification. Ethernet 10BASE-T* <sup>1</sup> /100BASE-TX* <sup>1</sup> /1000BASE-T* <sup>2</sup>
Display resolution	SVGA (800 x 600) or higher resolution

\*1 Use a shielded twisted-pair cable (Category 5 or higher).

\*2 Use a shielded twisted-pair cable (Category 5e or higher).

**Note:**

When installing, you must log in as a user with an computer administrator account (a user belonging to the Administrators group).

### Mac OS X

Operating system	Mac OS X v10.6.8 or later
CPU	Core 2 Duo 3.05 GHz or higher
Memory	1 GB or more available memory

Available hard disk space	32 GB or more
Display resolution	WXGA (1280 x 800) or higher resolution
Interface	Hi-Speed USB-Compatible with the USB 2.0 Specification. Ethernet 10BASE-T* <sup>1</sup> /100BASE-TX* <sup>1</sup> /1000BASE-T* <sup>2</sup>

\*1 Use a shielded twisted-pair cable (Category 5 or higher).

\*2 Use a shielded twisted-pair cable (Category 5e or higher).

Appendix

# Specifications Table

Printer Specifications	
Printing method	On-demand ink jet
Nozzle configuration	360 nozzles x 10 colors (Cyan, Light Cyan, Vivid Magenta, Vivid Light Magenta, Yellow, Orange, Green, Violet*/Light Light Black*, Light Black, Photo Black/Matte Black)  * Select one of these colors.
Resolution (maximum)	2880x1440 dpi
Control code	ESC/P raster (undisclosed command)
Media feed method	Friction feed
Built-in memory	256 MB for Main 128MB for Network
Rated voltage	AC 100 to 240 V
Rated frequency	50-60 Hz
Rated current	0.7 to 0.4 A
Power consumption	Printing: Approx. 52 W/Approx. 55 W (When the optional SpectroProofer is installed)  Sleep mode: Approx. 5.0 W* <sup>1</sup>  Power off: 0.5 W or less
Temperature	Operating: 10 to 35 °C (50 to 95°F)  Storage (before unpacking): -20 to 60 °C (within 120 hours at 60 °C, within a month at 40 °C)  Storage (after unpacking): -20 to 40 °C (within a month at 40 °C)
Humidity	Operating: 20 to 80% (without condensation)  Storage (before unpacking): 5 to 85% (without condensation)  Storage (after unpacking): 5 to 85% (without condensation)

Printer Specifications	
External size* <sup>2</sup>	(W) 863 x (D) 766 x (H) 405 mm
Weight	Approximately 52 kg (without ink cartridges)

\*1 Interface is 1000BASE-T

\*2 When the paper cassette and output tray are stored

Ink Specifications	
Type	Dedicated ink cartridges
Pigment ink	Black: Photo Black, Matte Black, Light Black, Light Light Black  Color: Green, Yellow, Orange, Cyan, Light Cyan, Vivid Magenta, Vivid Light Magenta, Violet
Use by date	See the date printed on the package (at normal temperature)
Print quality guarantee expiry	Six months (after installing in the printer)
Storage temperature	Uninstalled: -20 to 40°C (within a month at 40°C)  Installed: -20 to 40°C (within a month at 40°C)  Transporting: -20 to 60°C (within 1 month at 40°C, within 72 hours at 60°C)
Cartridge dimensions	200 ml: (W) 25 x (D) 200 x (H) 100 mm

**Important:**

- ❑ *The ink freezes if left at below -10°C for a long time. If it does freeze, leave it at room temperature (25°C) for at least four hours (without condensation).*
- ❑ *Do not refill the ink cartridges.*

---

## Information of EU Declaration of Conformity

The full text of the EU declaration of conformity of this equipment is available at the following internet address.

<http://www.epson.eu/conformity>

---

## Where To Get Help

---

### Technical Support Web Site

Epson's Technical Support Web Site provides help with problems that cannot be solved using the troubleshooting information in your product documentation. If you have a Web browser and can connect to the Internet, access the site at:

<http://support.epson.net/>

If you need the latest drivers, FAQs, manuals, or other downloadables, access the site at:

<http://www.epson.com>

Then, select the support section of your local Epson Web site.

## Contacting Epson Support

---

### Before Contacting Epson

If your Epson product is not operating properly and you cannot solve the problem using the troubleshooting information in your product documentation, contact Epson support services for assistance. If Epson support for your area is not listed below, contact the dealer where you purchased your product.

Epson support will be able to help you much more quickly if you give them the following information:

- Product serial number  
(The serial number label is usually on the back of the product.)
- Product model
- Product software version  
(Click **About**, **Version Info**, or similar button in the product software.)
- Brand and model of your computer
- Your computer operating system name and version
- Names and versions of the software applications you normally use with your product

## Where To Get Help

### Help for Users in North America

Epson provides the technical support services listed below.

#### Internet Support

Visit Epson's support website at <http://epson.com/support> and select your product for solutions to common problems. You can download drivers and documentation, get FAQs and troubleshooting advice, or e-mail Epson with your questions.

#### Speak to a Support Representative

Dial: (562) 276-1300 (U.S.), or (905) 709-9475 (Canada), 6 am to 6 pm, Pacific Time, Monday through Friday. Days and hours of support are subject to change without notice. Toll or long distance charges may apply.

Before you call Epson for support, please have the following information ready:

- Product name
- Product serial number
- Proof of purchase (such as a store receipt) and date of purchase
- Computer configuration
- Description of the problem

**Note:**

*For help using any other software on your system, see the documentation for that software for technical support information.*

#### Purchase Supplies and Accessories

You can purchase genuine Epson ink cartridges, ribbon cartridges, paper, and accessories from an Epson authorized reseller. To find the nearest reseller, call 800-GO-EPSON (800-463-7766). Or you can purchase online at <http://www.epsonstore.com> (U.S. sales) or <http://www.epson.ca> (Canadian sales).

### Help for Users in Europe

Check your **Pan-European Warranty Document** for information on how to contact Epson support.

### Help for Users in Australia

Epson Australia wishes to provide you with a high level of customer service. In addition to your product documentation, we provide the following sources for obtaining information:

#### Your Dealer

Don't forget that your dealer can often help identify and resolve problems. The dealer should always be the first call for advice on problems; they can often solve problems quickly and easily as well as give advice on the next step to take.

#### Internet URL

<http://www.epson.com.au>

Access the Epson Australia World Wide Web pages. Worth taking your modem here for the occasional surf! The site provides a download area for drivers, Epson contact points, new product information and technical support (e-mail).

#### Epson Helpdesk

Epson Helpdesk is provided as a final backup to make sure our clients have access to advice. Operators on the Helpdesk can aid you in installing, configuring and operating your Epson product. Our Pre-sales Helpdesk staff can provide literature on new Epson products and advise where the nearest dealer or service agent is located. Many types of queries are answered here.

The Helpdesk numbers are:

Phone: 1300 361 054

Fax: (02) 8899 3789

## Where To Get Help

We encourage you to have all the relevant information on hand when you ring. The more information you prepare, the faster we can help solve the problem. This information includes your Epson product documentation, type of computer, operating system, application programs, and any information you feel is required.

---

### Help for Users in Singapore

Sources of information, support, and services available from Epson Singapore are:

#### World Wide Web

(<http://www.epson.com.sg>)

Information on product specifications, drivers for download, Frequently Asked Questions (FAQ), Sales Enquiries, and Technical Support via e-mail are available.

#### Epson HelpDesk (Phone: (65) 6586 3111)

Our HelpDesk team can help you with the following over the phone:

- Sales enquiries and product information
- Product usage questions or problems
- Enquiries on repair service and warranty

---

### Help for Users in Thailand

Contacts for information, support, and services are:

#### World Wide Web

(<http://www.epson.co.th>)

Information on product specifications, drivers for download, Frequently Asked Questions (FAQ), and e-mail are available.

#### Epson Hotline (Phone: (66) 2685 -9899)

Our Hotline team can help you with the following over the phone:

- Sales enquiries and product information
- Product usage questions or problems
- Enquiries on repair service and warranty

---

### Help for Users in Vietnam

Contacts for information, support, and services are:

Epson Hotline (Phone): 84-8-823-9239

Service Center: 80 Truong Dinh Street,  
District 1, Hochiminh City  
Vietnam

---

### Help for Users in Indonesia

Contacts for information, support, and services are:

#### World Wide Web

(<http://www.epson.co.id>)

- Information on product specifications, drivers for download
- Frequently Asked Questions (FAQ), Sales Enquiries, questions through e-mail

#### Epson Hotline

- Sales enquiries and product information
- Technical support
 

Phone	(62) 21-572 4350
Fax	(62) 21-572 4357

#### Epson Service Center

Jakarta      Mangga Dua Mall 3rd floor No 3A/B  
Jl. Arteri Mangga Dua,  
Jakarta

Phone/Fax: (62) 21-62301104

## Where To Get Help

Bandung	Lippo Center 8th floor Jl. Gatot Subroto No.2 Bandung  Phone/Fax: (62) 22-7303766
Surabaya	Hitech Mall It IIB No. 12 Jl. Kusuma Bangsa 116 – 118 Surabaya  Phone: (62) 31-5355035 Fax: (62)31-5477837
Yogyakarta	Hotel Natour Garuda Jl. Malioboro No. 60 Yogyakarta  Phone: (62) 274-565478
Medan	Wisma HSBC 4th floor Jl. Diponegoro No. 11 Medan  Phone/Fax: (62) 61-4516173
Makassar	MTC Karebosi Lt. III Kav. P7-8 Jl. Ahmad Yani No.49 Makassar  Phone: (62)411-350147/411-350148

---

## Help for Users in Hong Kong

To obtain technical support as well as other after-sales services, users are welcome to contact Epson Hong Kong Limited.

### Internet Home Page

Epson Hong Kong has established a local home page in both Chinese and English on the Internet to provide users with the following information:

- Product information
- Answers to Frequently Asked Questions (FAQs)
- Latest versions of Epson product drivers

Users can access our World Wide Web home page at:

<http://www.epson.com.hk>

## Technical Support Hotline

You can also contact our technical staff at the following telephone and fax numbers:

Phone: (852) 2827-8911

Fax: (852) 2827-4383

---

## Help for Users in Malaysia

Contacts for information, support, and services are:

### World Wide Web

<http://www.epson.com.my>

- Information on product specifications, drivers for download
- Frequently Asked Questions (FAQ), Sales Enquiries, questions through e-mail

## Epson Trading (M) Sdn. Bhd.

Head Office.

Phone: 603-56288288

Fax: 603-56288388/399

### Epson Helpdesk

- Sales enquiries and product information (Infoline)  
Phone: 603-56288222
- Enquiries on repair services & warranty, product usage and technical support (Techline)  
Phone: 603-56288333

---

## Help for Users in India

Contacts for information, support, and services are:



## Where To Get Help

### World Wide Web

(<http://www.epson.co.in>)

Information on product specifications, drivers for download, and products enquiry are available.

### Epson India Head Office - Bangalore

Phone: 080-30515000

Fax: 30515005

### Epson India Regional Offices:

Location	Telephone number	Fax number
Mumbai	022-28261515/16/17	022-28257287
Delhi	011-30615000	011-30615005
Chennai	044-30277500	044-30277575
Kolkata	033-22831589/90	033-22831591
Hyderabad	040-66331738/39	040-66328633
Cochin	0484-2357950	0484-2357950
Coimbatore	0422-2380002	NA
Pune	020-30286000/30286001/30286002	020-30286000
Ahmedabad	079-26407176/77	079-26407347

### Helpline

For Service, Product info or to order a cartridge - 18004250011 (9AM - 9PM) - This is a Toll-free number.

For Service (CDMA & Mobile Users) - 3900 1600 (9AM - 6PM) Prefix local STD code

## Help for Users in the Philippines

To obtain technical support as well as other after sales services, users are welcome to contact the Epson Philippines Corporation at the telephone and fax numbers and e-mail address below:

Trunk Line: (63-2) 706 2609

Fax: (63-2) 706 2665

Helpdesk Direct Line: (63-2) 706 2625

E-mail: [epchelpdesk@epc.epson.com.ph](mailto:epchelpdesk@epc.epson.com.ph)

### World Wide Web

(<http://www.epson.com.ph>)

Information on product specifications, drivers for download, Frequently Asked Questions (FAQ), and E-mail Enquiries are available.

**Toll-Free No. 1800-1069-EPSON(37766)**

Our Hotline team can help you with the following over the phone:

- Sales enquiries and product information
- Product usage questions or problems
- Enquiries on repair service and warranty

---

# Software License Terms

---

---

## Open Source Software Licenses

---

### Bonjour

This printer product includes the open source software programs which apply the Apple Public Source License Version 1.2 or its latest version ("Bonjour Programs").

We provide the source code of the Bonjour Programs pursuant to the Apple Public Source License Version 1.2 or its latest version until five (5) years after the discontinuation of same model of this printer product. If you desire to receive the source code of the Bonjour Programs, please see the "Contacting Customer Support" in Appendix or Printing Guide of this User's Guide, and contact the customer support of your region.

You can redistribute Bonjour Programs and/or modify it under the terms of the Apple Public Source License Version 1.2 or its latest version.

These Bonjour Programs are WITHOUT ANY WARRANTY; without even the implied warranty of MERCHANTABILITY AND FITNESS FOR A PARTICULAR PURPOSE.

The Apple Public Source License Version 1.2 is as follows. You also can see the Apple Public Source License Version 1.2 at <http://www.opensource.apple.com/apsl/>.

APPLE PUBLIC SOURCE LICENSE  
Version 2.0 - August 6, 2003

1. General; Definitions. This License applies to any program or other work which Apple Computer, Inc. ("Apple") makes publicly available and which contains a notice placed by Apple identifying such program or work as "Original Code" and stating that it is subject to the terms of this Apple Public Source License version 2.0 ("License"). As used in this License:

1.1 "Applicable Patent Rights" mean: (a) in the case where Apple is the grantor of rights, (i) claims of patents that are now or hereafter acquired, owned by or assigned to Apple and (ii) that cover subject matter contained in the Original Code, but only to the extent necessary to use, reproduce and/or distribute the Original Code without infringement; and (b) in the case where You are the grantor of rights, (i) claims of patents that are now or hereafter acquired, owned by or assigned to You and (ii) that cover subject matter in Your Modifications, taken alone or in combination with Original Code.

1.2 "Contributor" means any person or entity that creates or contributes to the creation of Modifications.

1.3 "Covered Code" means the Original Code, Modifications, the combination of Original Code and any Modifications, and/or any respective portions thereof.

1.4 "Externally Deploy" means: (a) to sublicense, distribute or otherwise make Covered Code available, directly or indirectly, to anyone other than You; and/or (b) to use Covered Code, alone or as part of a Larger Work, in any way to provide a service, including but not limited to delivery of content, through electronic communication with a client other than You.

1.5 "Larger Work" means a work which combines Covered Code or portions thereof with code not governed by the terms of this License.

## Software License Terms

1.6 "Modifications" mean any addition to, deletion from, and/or change to, the substance and/or structure of the Original Code, any previous Modifications, the combination of Original Code and any previous Modifications, and/or any respective portions thereof. When code is released as a series of files, a Modification is: (a) any addition to or deletion from the contents of a file containing Covered Code; and/or (b) any new file or other representation of computer program statements that contains any part of Covered Code.

1.7 "Original Code" means (a) the Source Code of a program or other work as originally made available by Apple under this License, including the Source Code of any updates or upgrades to such programs or works made available by Apple under this License, and that has been expressly identified by Apple as such in the header file(s) of such work; and (b) the object code compiled from such Source Code and originally made available by Apple under this License

1.8 "Source Code" means the human readable form of a program or other work that is suitable for making modifications to it, including all modules it contains, plus any associated interface definition files, scripts used to control compilation and installation of an executable (object code).

1.9 "You" or "Your" means an individual or a legal entity exercising rights under this License. For legal entities, "You" or "Your" includes any entity which controls, is controlled by, or is under common control with, You, where "control" means (a) the power, direct or indirect, to cause the direction or management of such entity, whether by contract or otherwise, or (b) ownership of fifty percent (50%) or more of the outstanding shares or beneficial ownership of such entity.

2. Permitted Uses; Conditions & Restrictions. Subject to the terms and conditions of this License, Apple hereby grants You, effective on the date You accept this License and download the Original Code, a world-wide, royalty-free, non-exclusive license, to the extent of Apple's Applicable Patent Rights and copyrights covering the Original Code, to do the following:

2.1 Unmodified Code. You may use, reproduce, display, perform, internally distribute within Your organization, and Externally Deploy verbatim, unmodified copies of the Original Code, for commercial or non-commercial purposes, provided that in each instance:

(a) You must retain and reproduce in all copies of Original Code the copyright and other proprietary notices and disclaimers of Apple as they appear in the Original Code, and keep intact all notices in the Original Code that refer to this License; and

(b) You must include a copy of this License with every copy of Source Code of Covered Code and documentation You distribute or Externally Deploy, and You may not offer or impose any terms on such Source Code that alter or restrict this License or the recipients' rights hereunder, except as permitted under Section 6.

2.2 Modified Code. You may modify Covered Code and use, reproduce, display, perform, internally distribute within Your organization, and Externally Deploy Your Modifications and Covered Code, for commercial or non-commercial purposes, provided that in each instance You also meet all of these conditions:

(a) You must satisfy all the conditions of Section 2.1 with respect to the Source Code of the Covered Code;

(b) You must duplicate, to the extent it does not already exist, the notice in Exhibit A in each file of the Source Code of all Your Modifications, and cause the modified files to carry prominent notices stating that You changed the files and the date of any change; and

(c) If You Externally Deploy Your Modifications, You must make Source Code of all Your Externally Deployed Modifications either available to those to whom You have Externally Deployed Your Modifications, or publicly available. Source Code of Your Externally Deployed Modifications must be released under the terms set forth in this License, including the license grants set forth in Section 3 below, for as long as you Externally Deploy the Covered Code or twelve (12) months from the date of initial External Deployment, whichever is longer. You should preferably distribute the Source Code of Your Externally Deployed Modifications electronically (e.g. download from a web site).

## Software License Terms

2.3 Distribution of Executable Versions. In addition, if You Externally Deploy Covered Code (Original Code and/or Modifications) in object code, executable form only, You must include a prominent notice, in the code itself as well as in related documentation, stating that Source Code of the Covered Code is available under the terms of this License with information on how and where to obtain such Source Code.

2.4 Third Party Rights. You expressly acknowledge and agree that although Apple and each Contributor grants the licenses to their respective portions of the Covered Code set forth herein, no assurances are provided by Apple or any Contributor that the Covered Code does not infringe the patent or other intellectual property rights of any other entity. Apple and each Contributor disclaim any liability to You for claims brought by any other entity based on infringement of intellectual property rights or otherwise. As a condition to exercising the rights and licenses granted hereunder, You hereby assume sole responsibility to secure any other intellectual property rights needed, if any. For example, if a third party patent license is required to allow You to distribute the Covered Code, it is Your responsibility to acquire that license before distributing the Covered Code.

3. Your Grants. In consideration of, and as a condition to, the licenses granted to You under this License, You hereby grant to any person or entity receiving or distributing Covered Code under this License a non-exclusive, royalty-free, perpetual, irrevocable license, under Your Applicable Patent Rights and other intellectual property rights (other than patent) owned or controlled by You, to use, reproduce, display, perform, modify, sublicense, distribute and Externally Deploy Your Modifications of the same scope and extent as Apple's licenses under Sections 2.1 and 2.2 above.

4. Larger Works. You may create a Larger Work by combining Covered Code with other code not governed by the terms of this License and distribute the Larger Work as a single product. In each such instance, You must make sure the requirements of this License are fulfilled for the Covered Code or any portion thereof.

5. Limitations on Patent License. Except as expressly stated in Section 2, no other patent rights, express or implied, are granted by Apple herein. Modifications and/or Larger Works may require additional patent licenses from Apple which Apple may grant in its sole discretion.

6. Additional Terms. You may choose to offer, and to charge a fee for, warranty, support, indemnity or liability obligations and/or other rights consistent with the scope of the license granted herein ("Additional Terms") to one or more recipients of Covered Code. However, You may do so only on Your own behalf and as Your sole responsibility, and not on behalf of Apple or any Contributor. You must obtain the recipient's agreement that any such Additional Terms are offered by You alone, and You hereby agree to indemnify, defend and hold Apple and every Contributor harmless for any liability incurred by or claims asserted against Apple or such Contributor by reason of any such Additional Terms.

7. Versions of the License. Apple may publish revised and/or new versions of this License from time to time. Each version will be given a distinguishing version number. Once Original Code has been published under a particular version of this License, You may continue to use it under the terms of that version. You may also choose to use such Original Code under the terms of any subsequent version of this License published by Apple. No one other than Apple has the right to modify the terms applicable to Covered Code created under this License.

## Software License Terms

8. NO WARRANTY OR SUPPORT. The Covered Code may contain in whole or in part pre-release, untested, or not fully tested works. The Covered Code may contain errors that could cause failures or loss of data, and may be incomplete or contain inaccuracies. You expressly acknowledge and agree that use of the Covered Code, or any portion thereof, is at Your sole and entire risk. THE COVERED CODE IS PROVIDED "AS IS" AND WITHOUT WARRANTY, UPGRADES OR SUPPORT OF ANY KIND AND APPLE AND APPLE'S LICENSOR(S) (COLLECTIVELY REFERRED TO AS "APPLE" FOR THE PURPOSES OF SECTIONS 8 AND 9) AND ALL CONTRIBUTORS EXPRESSLY DISCLAIM ALL WARRANTIES AND/OR CONDITIONS, EXPRESS OR IMPLIED, INCLUDING, BUT NOT LIMITED TO, THE IMPLIED WARRANTIES AND/OR CONDITIONS OF MERCHANTABILITY, OF SATISFACTORY QUALITY, OF FITNESS FOR A PARTICULAR PURPOSE, OF ACCURACY, OF QUIET ENJOYMENT, AND NONINFRINGEMENT OF THIRD PARTY RIGHTS. APPLE AND EACH CONTRIBUTOR DOES NOT WARRANT AGAINST INTERFERENCE WITH YOUR ENJOYMENT OF THE COVERED CODE, THAT THE FUNCTIONS CONTAINED IN THE COVERED CODE WILL MEET YOUR REQUIREMENTS, THAT THE OPERATION OF THE COVERED CODE WILL BE UNINTERRUPTED OR ERROR-FREE, OR THAT DEFECTS IN THE COVERED CODE WILL BE CORRECTED. NO ORAL OR WRITTEN INFORMATION OR ADVICE GIVEN BY APPLE, AN APPLE AUTHORIZED REPRESENTATIVE OR ANY CONTRIBUTOR SHALL CREATE A WARRANTY. You acknowledge that the Covered Code is not intended for use in the operation of nuclear facilities, aircraft navigation, communication systems, or air traffic control machines in which case the failure of the Covered Code could lead to death, personal injury, or severe physical or environmental damage.

9. LIMITATION OF LIABILITY. TO THE EXTENT NOT PROHIBITED BY LAW, IN NO EVENT SHALL APPLE OR ANY CONTRIBUTOR BE LIABLE FOR ANY INCIDENTAL, SPECIAL, INDIRECT OR CONSEQUENTIAL DAMAGES ARISING OUT OF OR RELATING TO THIS LICENSE OR YOUR USE OR INABILITY TO USE THE COVERED CODE, OR ANY PORTION THEREOF, WHETHER UNDER A THEORY OF CONTRACT, WARRANTY, TORT (INCLUDING NEGLIGENCE), PRODUCTS LIABILITY OR OTHERWISE, EVEN IF APPLE OR SUCH CONTRIBUTOR HAS BEEN ADVISED OF THE POSSIBILITY OF SUCH DAMAGES AND NOTWITHSTANDING THE FAILURE OF ESSENTIAL PURPOSE OF ANY REMEDY. SOME JURISDICTIONS DO NOT ALLOW THE LIMITATION OF LIABILITY OF INCIDENTAL OR CONSEQUENTIAL DAMAGES, SO THIS LIMITATION MAY NOT APPLY TO YOU. In no event shall Apple's total liability to You for all damages (other than as may be required by applicable law) under this License exceed the amount of fifty dollars (\$50.00).

10. Trademarks. This License does not grant any rights to use the trademarks or trade names "Apple", "Apple Computer", "Mac", "Mac OS", "QuickTime", "QuickTime Streaming Server" or any other trademarks, service marks, logos or trade names belonging to Apple (collectively "Apple Marks") or to any trademark, service mark, logo or trade name belonging to any Contributor. You agree not to use any Apple Marks in or as part of the name of products derived from the Original Code or to endorse or promote products derived from the Original Code other than as expressly permitted by and in strict compliance at all times with Apple's third party trademark usage guidelines which are posted at <http://www.apple.com/legal/guidelinesfor3rdparties.html>.

11. Ownership. Subject to the licenses granted under this License, each Contributor retains all rights, title and interest in and to any Modifications made by such Contributor. Apple retains all rights, title and interest in and to the Original Code and any Modifications made by or on behalf of Apple ("Apple Modifications"), and such Apple Modifications will not be automatically subject to this License. Apple may, at its sole discretion, choose to license such Apple Modifications under this License, or on different terms from those contained in this License or may choose not to license them at all.

12. Termination.

12.1 Termination. This License and the rights granted hereunder will terminate:

(a) automatically without notice from Apple if You fail to comply with any term(s) of this License and fail to cure such breach within 30 days of becoming aware of such breach;

(b) immediately in the event of the circumstances described in Section 13.5(b); or

## Software License Terms

(c) automatically without notice from Apple if You, at any time during the term of this License, commence an action for patent infringement against Apple; provided that Apple did not first commence an action for patent infringement against You in that instance.

12.2 Effect of Termination. Upon termination, You agree to immediately stop any further use, reproduction, modification, sublicensing and distribution of the Covered Code. All sublicenses to the Covered Code which have been properly granted prior to termination shall survive any termination of this License. Provisions which, by their nature, should remain in effect beyond the termination of this License shall survive, including but not limited to Sections 3, 5, 8, 9, 10, 11, 12.2 and 13. No party will be liable to any other for compensation, indemnity or damages of any sort solely as a result of terminating this License in accordance with its terms, and termination of this License will be without prejudice to any other right or remedy of any party.

### 13. Miscellaneous.

13.1 Government End Users. The Covered Code is a "commercial item" as defined in FAR 2.101. Government software and technical data rights in the Covered Code include only those rights customarily provided to the public as defined in this License. This customary commercial license in technical data and software is provided in accordance with FAR 12.211 (Technical Data) and 12.212 (Computer Software) and, for Department of Defense purchases, DFAR 252.227-7015 (Technical Data -- Commercial Items) and 227.7202-3 (Rights in Commercial Computer Software or Computer Software Documentation). Accordingly, all U.S. Government End Users acquire Covered Code with only those rights set forth herein.

13.2 Relationship of Parties. This License will not be construed as creating an agency, partnership, joint venture or any other form of legal association between or among You, Apple or any Contributor, and You will not represent to the contrary, whether expressly, by implication, appearance or otherwise.

13.3 Independent Development. Nothing in this License will impair Apple's right to acquire, license, develop, have others develop for it, market and/or distribute technology or products that perform the same or similar functions as, or otherwise compete with, Modifications, Larger Works, technology or products that You may develop, produce, market or distribute.

13.4 Waiver; Construction. Failure by Apple or any Contributor to enforce any provision of this License will not be deemed a waiver of future enforcement of that or any other provision. Any law or regulation which provides that the language of a contract shall be construed against the drafter will not apply to this License.

13.5 Severability. (a) If for any reason a court of competent jurisdiction finds any provision of this License, or portion thereof, to be unenforceable, that provision of the License will be enforced to the maximum extent permissible so as to effect the economic benefits and intent of the parties, and the remainder of this License will continue in full force and effect. (b) Notwithstanding the foregoing, if applicable law prohibits or restricts You from fully and/or specifically complying with Sections 2 and/or 3 or prevents the enforceability of either of those Sections, this License will immediately terminate and You must immediately discontinue any use of the Covered Code and destroy all copies of it that are in your possession or control.

13.6 Dispute Resolution. Any litigation or other dispute resolution between You and Apple relating to this License shall take place in the Northern District of California, and You and Apple hereby consent to the personal jurisdiction of, and venue in, the state and federal courts within that District with respect to this License. The application of the United Nations Convention on Contracts for the International Sale of Goods is expressly excluded.

13.7 Entire Agreement; Governing Law. This License constitutes the entire agreement between the parties with respect to the subject matter hereof. This License shall be governed by the laws of the United States and the State of California, except that body of California law concerning conflicts of law.

Where You are located in the province of Quebec, Canada, the following clause applies: The parties hereby confirm that they have requested that this License and all related documents be drafted in English.

## Software License Terms

Les parties ont exigé que le présent contrat et tous les documents connexes soient rédigés en anglais.

EXHIBIT A.

"Portions Copyright (c) 1999-2003 Apple Computer, Inc. All Rights Reserved.

This file contains Original Code and/or Modifications of Original Code as defined in and that are subject to the Apple Public Source License Version 2.0 (the 'License'). You may not use this file except in compliance with the License. Please obtain a copy of the License at <http://www.opensource.apple.com/apsl/> and read it before using this file.

The Original Code and all software distributed under the License are distributed on an 'AS IS' basis, WITHOUT WARRANTY OF ANY KIND, EITHER EXPRESS OR IMPLIED, AND APPLE HEREBY DISCLAIMS ALL SUCH WARRANTIES, INCLUDING WITHOUT LIMITATION, ANY WARRANTIES OF MERCHANTABILITY, FITNESS FOR A PARTICULAR PURPOSE, QUIET ENJOYMENT OR NON-INFRINGEMENT. Please see the License for the specific language governing rights and limitations under the License."

## Other Software Licenses

---

### Info-ZIP copyright and license

This is version 2007-Mar-4 of the Info-ZIP license. The definitive version of this document should be available at <ftp://ftp.info-zip.org/pub/infozip/license.html> indefinitely and a copy at <http://www.info-zip.org/pub/infozip/license.html>.

Copyright © 1990-2007 Info-ZIP. All rights reserved.

For the purposes of this copyright and license, "Info-ZIP" is defined as the following set of individuals:

Mark Adler, John Bush, Karl Davis, Harald Denker, Jean-Michel Dubois, Jean-loup Gailly, Hunter Goatley, Ed Gordon, Ian Gorman, Chris Herborth, Dirk Haase, Greg Hartwig, Robert Heath, Jonathan Hudson, Paul Kienitz, David Kirschbaum, Johnny Lee, Onno van der Linden, Igor Mandrichenko, Steve P. Miller, Sergio Monesi, Keith Owens, George Petrov, Greg Roelofs, Kai Uwe Rommel, Steve Salisbury, Dave Smith, Steven M. Schweda, Christian Spieler, Cosmin Truta, Antoine Verheijen, Paul von Behren, Rich Wales, Mike White.

Permission is granted to anyone to use this software for any purpose, including commercial applications, and to alter it and redistribute it freely, subject to the above disclaimer and the following restrictions:

1. Redistributions of source code (in whole or in part) must retain the above copyright notice, definition, disclaimer, and this list of conditions.
2. Redistributions in binary form (compiled executables and libraries) must reproduce the above copyright notice, definition, disclaimer, and this list of conditions in documentation and/or other materials provided with the distribution. The sole exception to this condition is redistribution of a standard UnZipSFX binary (including SFXWiz) as part of a self-extracting archive; that is permitted without inclusion of this license, as long as the normal SFX banner has not been removed from the binary or disabled.

## Software License Terms

3. Altered versions--including, but not limited to, ports to new operating systems, existing ports with new graphical interfaces, versions with modified or added functionality, and dynamic, shared, or static library versions not from Info-ZIP--must be plainly marked as such and must not be misrepresented as being the original source or, if binaries, compiled from the original source. Such altered versions also must not be misrepresented as being Info-ZIP releases--including, but not limited to, labeling of the altered versions with the names "Info-ZIP" (or any variation thereof, including, but not limited to, different capitalizations), "Pocket UnZip," "WiZ" or "MacZip" without the explicit permission of Info-ZIP. Such altered versions are further prohibited from misrepresentative use of the Zip-Bugs or Info-ZIP e-mail addresses or the Info-ZIP URL(s), such as to imply Info-ZIP will provide support for the altered versions.
4. Info-ZIP retains the right to use the names "Info-ZIP," "Zip," "UnZip," "UnZipSFX," "WiZ," "Pocket UnZip," "Pocket Zip," and "MacZip" for its own source and binary releases.