

Floor-to-Ceiling Mount for 32" to 65" TVs and Monitors - Height Adjustable, Shelf for A/V Source

MODEL NUMBER: DMFC3265M

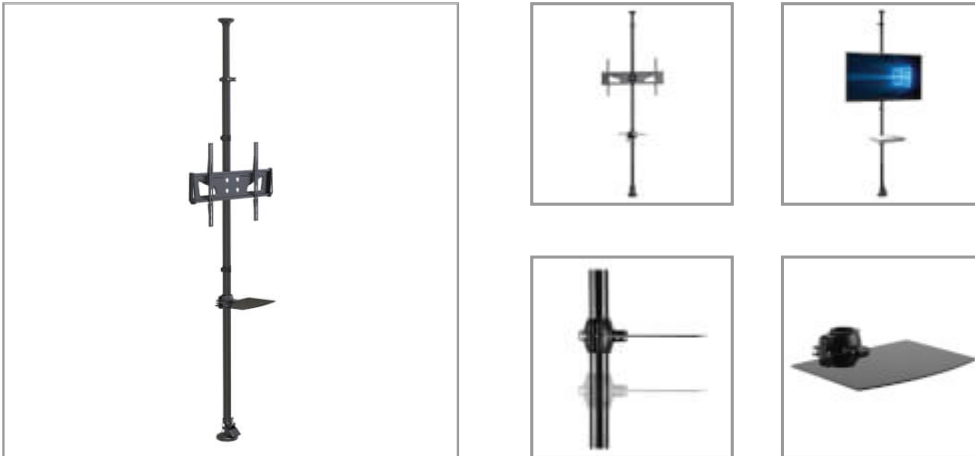

An adjustable-height support pole provides flexible screen placement in rooms with up to 12-foot ceilings. Includes A/V source shelf.

Features

Floor-to-Ceiling Mount Works in Almost Any Room with a Ceiling up to 12 ft. High

The DMFC3265M mount offers flexible screen placement in rooms where installing a display mount on a wall is not possible or desirable. Made of steel with a black powder-coated finish, the support pole has telescoping adjustment to mount in rooms with solid ceilings from 6.8 to 12 feet high. A pressure clamp at the base secures the pole. As long as you have access to power, you can mount the support pole anywhere in the room. Pole diameter is approximately 1.7 inches; the top telescoping section is slightly narrower.

Easily Mount a 32" to 65" Display and Adjust the Viewing Angle

Mount the display bracket to the support pole at the best height for your application. Designed for flat-panel displays from 32 to 65 inches, the DMFC3265M supports the following VESA mounting hole patterns: 200 x 200, 300 x 300, 400 x 200, 400 x 400 and 600 x 400. Maximum supported weight is 55 lb. The mount offers -3° to +3° screen level adjustment and ±180° swivel to improve the viewing angle for the audience.

Store Your Video Source on the Convenient Height-Adjustable Shelf

The shelf mounts to the support pole at a height of your choosing. It provides a convenient place for your laptop, DVD or Blu-ray player or other video source. The shelf is 11 x 7.8 inches and supports up to 11 lb. Cable guides route cords along the pole to reduce clutter.

Keep the Mount Portable or Choose Permanent Installation

Perfect for temporary digital signage, the DMFC3265M does not require permanent mounting. When needs change, it can be moved without damaging the ceiling or floor. You also have the option of securing the pole to a permanently mounted floor anchor (included).

Highlights

- Accommodates flat-panel displays from 32 to 65 in. and up to 55 lb.
- Support pole adjusts for ceilings up to 12 ft. high
- Pressure clamp at the floor holds mount in place
- Shelf supports a laptop, Blu-ray player or other component up to 11 lb.
- Option for mounting to a permanent floor anchor

Applications

- Show video in a multipurpose area not equipped with A/V equipment
- Create temporary digital signage in a retail environment
- Mount an extra screen in a lobby for a special event
- Move a screen to a different corner as seating arrangements change in a living room or conference room
- Add a screen to a classroom without drilling holes for a wall-mount display

Package Includes

- All DMFC3265M components (some assembly required)
- Assembly fasteners
- Display mounting fasteners
- Hex keys
- Owner's manual

Specifications



Tripp Lite
1111 W. 35th Street
Chicago, IL 60609 USA
Telephone: 773.869.1234
www.tripplite.com

OVERVIEW	
UPC Code	037332239396
PHYSICAL	
Mounting Location	Floor
Shipping Dimensions (hwd / in.)	84.60 x 9.10 x 5.10
Shipping Dimensions (hwd / cm)	214.88 x 23.11 x 12.95
Shipping Weight (lbs.)	21.40
Shipping Weight (kg)	9.71
Unit Dimensions (hwd / in.)	149.6 x 28.3 x 7.87
Unit Dimensions (hwd / cm)	379.98 x 71.8 x 19.99
Unit Weight (lbs.)	16.7
Unit Weight (kg)	7.57
Material of Construction	Steel
Color	Black
VESA Pattern (mm)	200x200; 300x300; 400x200; 400x400; 600x400
Maximum Weight Capacity (lbs.)	88
Maximum Weight Capacity (kg)	40
Number of Displays	1
FEATURES & SPECIFICATIONS	
Tools Necessary	Yes
Cord Management	No
WARRANTY	
Product Warranty Period (Worldwide)	5-year limited warranty

© 2019 Tripp Lite. All rights reserved. All product and company names are trademarks or registered trademarks of their respective holders. Use of them does not imply any affiliation with or endorsement by them. Tripp Lite has a policy of continuous improvement. Specifications are subject to change without notice. Tripp Lite uses primary and third-party agencies to test its products for compliance with standards. See a list of Tripp Lite's testing agencies: <https://www.tripplite.com/products/product-certification-agencies>