



S27B970D

User manual

The color and the appearance may differ depending on the product, and the specifications are subject to change without prior notice to improve the performance.

Table of Contents

Chapter. 1 BEFORE USING THE PRODUCT

- 5 **Copyright**
- 6 **Securing the Installation Space**
- 6 **Safety Precautions**
- 6 Symbols
- 7 **Cleaning**
- 7 Electricity and Safety
- 8 Installation and Safety
- 9 Operation and Safety
- 12 **Correct posture to use the product**

Chapter. 2 PREPARATION

- 13 **Checking the Contents**
- 13 Removing the Packaging
- 14 Checking the Components
- 15 **Parts**
- 15 Front Buttons
- 16 Rear View
- 17 Side View
- 17 **Adjusting the Product Tilt**
- 18 **Adjusting the Product Height**

Chapter. 3 USING NCE (NATURAL COLOR EXPERT)

- 19 **What is Monitor Calibration?**
- 19 Compatible Types of Calibrators
- 20 **What is NCE (Natural Color Expert)?**
- 20 NCE Program Installation/Uninstallation
- 21 **Starting NCE (Natural Color Expert)**
- 21 Connecting the Calibrator
- 21 **Features of the NCE Program**
- 21 Layout and Menu Items on the NCE Home Screen
- 22 Profile List
- 22 Layout and Menu Items on the Preference Screen
- 23 Layout and Menu Items on the Uniformity Screen
- 23 Layout and Menu Items on the Edit Screen
- 24 Layout and Menu Items on the Calibration Screen
- 24 Layout and Menu Items on the New Profile Screen
- 27 Preparing for Calibration
- 27 Completing Calibration

Chapter. 4 USING MHL

- 28 **MHL (Mobile High-Definition Link)**
- 28 Using MHL
- 29 Disabling MHL

Chapter. 5 CONNECTING AND USING A SOURCE DEVICE

- 30 Checklist before Connecting to Source Devices**
- 30 Pre-connection Checkpoints
- 30 Connecting the Power**
- 31 Connecting and Using a PC**
- 31 Connecting to a PC
- 33 Driver Installation
- 34 Setting Optimum Resolution
- 34 Changing the Resolution Using a PC
- 36 Connecting to a Video Device**

Chapter. 6 SCREEN SETUP

- 37 Dynamic Contrast**
- 37 Changing the Dynamic Contrast Setting
- 37 Brightness**
- 37 Configuring Brightness
- 38 Contrast**
- 38 Configuring Contrast
- 38 Sharpness**
- 38 Configuring Sharpness
- 39 Response Time**
- 39 Configuring Response Time
- 39 HDMI Black Level**
- 39 Configuring HDMI Black Level

Chapter. 7 CONFIGURING THE TINT SETTINGS

- 40 Color Mode**
- 40 Configuring Color Mode
- 41 Red**
- 41 Configuring Red
- 41 Green**
- 41 Configuring Green
- 42 Blue**
- 42 Configuring Blue
- 42 Color Temp.**
- 42 Configuring Color Temp.
- 43 Gamma**
- 43 Configuring Gamma

Chapter. 8 RESIZING OR RELOCATING THE SCREEN

- 44 Image Size**
- 44 Configuring Image Size
- 45 H-Position**
- 45 Configuring H-Position
- 45 V-Position**
- 45 Configuring V-Position
- 46 Menu H-Position**
- 46 Configuring Menu H-Position
- 46 Menu V-Position**
- 46 Configuring Menu V-Position

Chapter. 9 SETUP AND RESET

- 47 Eco Saving**
- 47 Configuring Eco Saving
- 47 Menu Transparency**
- 47 Configuring Menu Transparency
- 48 Language**
- 48 Configuring Language
- 48 PC/AV Mode**
- 48 Configuring PC/AV Mode
- 49 Auto Source**
- 49 Configuring Auto Source
- 49 Display Time**
- 49 Configuring Display Time
- 50 Key Repeat Time**
- 50 Configuring Key Repeat Time
- 50 Off Timer On/Off**
- 50 Configuring Off Timer On/Off
- 51 Off Timer Setting**
- 51 Configuring Off Timer Setting
- 51 Reset**
- 51 Restoring the default settings (Reset)

Chapter. 10

INFORMATION MENU AND OTHERS

- 52** **INFORMATION**
- 52 Viewing information (INFORMATION)
- 52** **Configuring Color Mode in the Initial Screen**
- 53** **Configuring Volume in the Initial Screen**
- 53** **Configuring Brightness and Contrast in the Initial Screen**

Chapter. 11

TROUBLESHOOTING GUIDE

- 54** **Requirements Before Contacting Samsung Customer Service Center**
- 54 Testing the Product
- 54 Checking the Resolution and Frequency
- 54 Check the following.
- 56** **Q & A**

Chapter. 12

SPECIFICATIONS

- 57** **General**
- 58** **PowerSaver**
- 58** **Preset Timing Modes**

Chapter. 13

APPENDIX

- 60** **Contact SAMSUNG WORLDWIDE**
- 63** **Responsibility for the Pay Service (Cost to Customers)**
- 64** **Correct Disposal**
- 65** **Terminology**
- 65 OSD(On Screen Display)
- 65 Gamma
- 65 Grey scale
- 65 Scanning rate
- 65 Horizontal Frequency
- 65 Vertical Frequency
- 65 Resolution
- 65 Plug & Play
- 65 MHL (Mobile High-Definition Link)

Before Using the Product

Copyright

The contents of this manual are subject to change without notice to improve quality.

© 2012 Samsung Electronics

Samsung Electronics owns the copyright for this manual.

Use or reproduction of this manual in parts or entirety without the authorization of Samsung Electronics is prohibited.

The SAMSUNG and SyncMaster logos are registered trademarks of Samsung Electronics.

Microsoft® and Windows are registered trademarks of Microsoft Corporation.

VESA, DPM and DDC are registered trademarks of the Video Electronics Standards Association.

Ownership of all other trademarks is attributed to their due owner.

- An administration fee may be charged if either:
 - (a) an engineer is called out at your request and there is no defect in the product (i.e. where you have failed to read this user manual).
 - (b) you bring the unit to a repair center and there is no defect in the product (i.e. where you have failed to read this user manual).
- The amount of such administration charge will be advised to you before any work or home visit is carried out.

Securing the Installation Space

Ensure some space around the product for ventilation. An internal temperature rise may cause fire and damage the product. Be sure to allow the amount of space as shown below or greater when installing the product.

- ✦ The exterior may differ depending on the product.

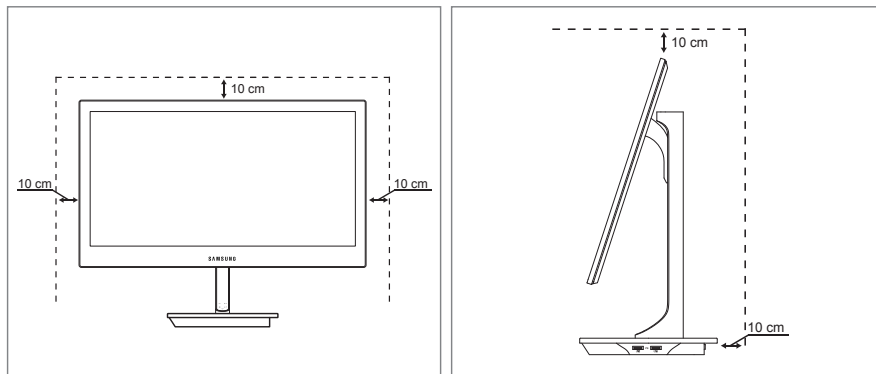

Precautions for storage

High-glossy models can develop white stains on the surface if an ultrasonic wave humidifier is used nearby.

- ✦ Contact your nearest Samsung Customer Service Center if you want to clean the inside of the product (Service fee will be charged.)

Safety Precautions

Caution

Do not open the cover. You may suffer an electric shock. The components inside this product must not be repaired by home users. Contact a technician for repair.

Symbols

Warning A serious or fatal injury may result if instructions are not followed.

Caution Personal injury or damage to properties may result if instructions are not followed.



Activities marked by this symbol are prohibited.



Instructions marked by this symbol must be followed.

Cleaning

The following images are for reference only. Real-life situations may differ from what is shown in the images.

Exercise care when cleaning as the panel and exterior of advanced LCDs are easily scratched.

Take the following steps when cleaning.

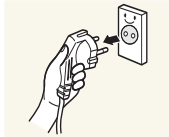

1. Power off the product.
2. Remove the power cable from the product.

NOTE

Hold the power cable by the plug and do not touch the cable with wet hands. Otherwise, an electric shock may result.

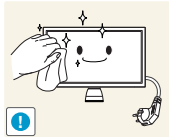

3. Wipe the product screen using a clean, soft and dry cloth.
 - Do not use detergents that contain alcohol, solvent or surface-active agents.
 - Do not spray water or detergent directly on the product.

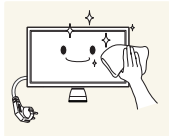

4. To clean the exterior of the product, use a moist soft cloth and wring thoroughly before wiping the exterior.



5. After cleaning the product, connect the power cable to the product.
6. Power on the product to use it.

Electricity and Safety

The following images are for reference only. Real-life situations may differ from what is shown in the images.

Warning

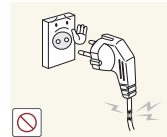

Do not use a damaged power cable or plug, or a loose power socket.

- An electric shock or fire may result.

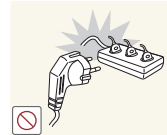

Do not use multiple products with a single power socket.

- Otherwise, the socket may cause a fire.



Do not touch the power cable with wet hands. Otherwise, an electric shock may result.

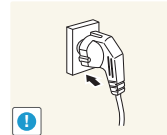

Insert the power cable all the way in so it is not loose.

- An unsecure connection may cause a fire.

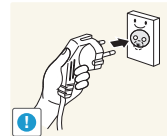

Be sure to plug the power cable into a grounded power socket. (type 1 insulated devices only).

- An electric shock or injury may result.

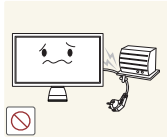

Do not bend or pull the power cable with force. Also, do not place a heavy object on the power cable.

- Damage to the cord may result in a fire or electric shock.

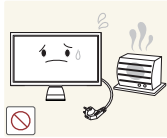

Do not place the power cable or product near heat sources.

- A fire or electric shock may result.

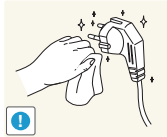

Clean any dust around the pins of the power cable or the power outlet using a dry cloth.

- A fire may result.

Caution



Do not disconnect the power cable while the product is being used.

- The product may become damaged by an electric shock.

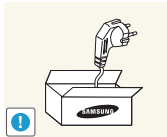

Only use the power cable provided with your product by Samsung. Do not use the power cord with other products.

- A fire or electric shock may result.

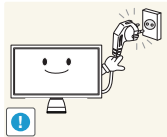

Keep the power socket where the power cable is connected unobstructed.

- In the event of a problem with the product, you must disconnect the power cable to cut the power supply to the product.

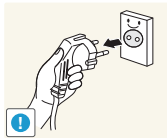

Hold the plug when disconnecting the power cable from the power socket.

- A fire or electric shock may result.

Installation and Safety

- ▣ The following images are for reference only. Real-life situations may differ from what is shown in the images.

Warning

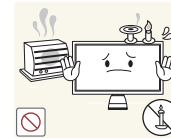

DO NOT PLACE CANDLES, INSECT REPELLANTS OR CIGARETTES ON TOP OF THE PRODUCT. DO NOT INSTALL THE PRODUCT NEAR HEAT SOURCES.

- A fire may result.



Do not install the product in poorly ventilated spaces such as a bookcase or closet.

- An increased internal temperature may cause a fire.



Keep the plastic packaging out of the reach of children.

- Children may suffocate.



Do not install the product on an unstable or vibrating surface (insecure shelf, sloped surface, etc.)

- The product may fall and become damaged and/or cause an injury.
- Using the product in an area with excess vibration may damage the product or cause a fire.

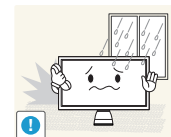

Do not install the product in a vehicle or a place exposed to dust, moisture (water drips, etc.), oil, or smoke.

- A fire or electric shock may result.

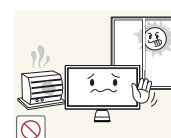

Do not expose the product to direct sunlight, heat, or a hot object such as a stove.

- The product lifespan may be reduced or a fire may result.



Do not install the product within the reach of young children.
The product may fall and injure children.



Edible oil, such as soybean oil, can damage or deform the product. Do not install the product in a kitchen or near a kitchen counter.

Caution



Do not drop the product while moving.
- Product failure or personal injury may result.

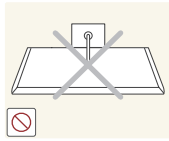

Do not set down the product on its front.
- The screen may become damaged.

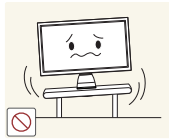

When installing the product on a cabinet or shelf, make sure that the bottom edge of the front of the product is not protruding.
- The product may fall and break or cause a personal injury.
- Install the product only on cabinets or shelves of the right size.

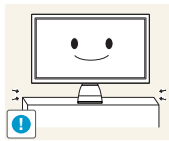

Set down the product gently
- Product failure or personal injury may result.



Installing the product in an unusual place (a place exposed to a lot of fine particles, chemical substances or extreme temperatures, or an airport or train station where the product should operate continuously for an extended period of time) may seriously affect its performance.

- Be sure to consult Samsung Customer Service Center if you want to install the product at such a place.

Operation and Safety

▣ The following images are for reference only. Real-life situations may differ from what is shown in the images.

Warning



There is a high voltage inside the product. Never disassemble, repair or modify the product yourself.

- A fire or electric shock may result.
- Contact Samsung Customer Service Center for repairs.

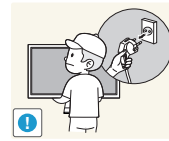

Before moving the product, turn off the power switch and disconnect the power cable and all other connected cables.

- Damage to the cord may result in a fire or electric shock.



If the product generates abnormal sounds, a burning smell or smoke, disconnect the power cable immediately and contact Samsung Customer Service Center.

- An electric shock or fire may result.

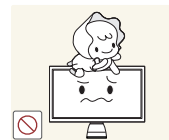

Do not let children hang from the product or climb on top of it.

- Children may become injured or seriously harmed.



If the product is dropped or the outer case is damaged, turn off the power switch and disconnect the power cable. Then contact Samsung Customer Service Center.

- Continued use can result in a fire or electric shock.



Do not leave heavy objects or items that children like (toys, sweets, etc.) on top of the product.

- The product or heavy objects may fall as children try to reach for the toys or sweets resulting in a serious injury.

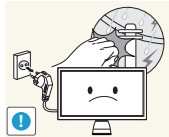

If there is a thunderstorm or lightning strike, turn off the power and disconnect the power cable.

- A fire or electric shock may result.



Do not drop objects on the product or apply impact.

- A fire or electric shock may result.



Do not pull on the product holding only the power cable or any other cable.

- Product failure, an electric shock or fire may result from a damaged cable.

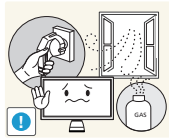

If a gas leakage is found, do not touch the product or power cable. Also, ventilate the area immediately.

- Sparks can cause an explosion or fire.

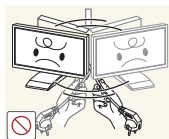

Do not lift or move the product by pulling the power cable or any cable.

- Product failure, an electric shock or fire may result from a damaged cable.

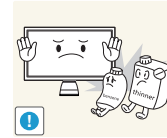

Do not use or keep combustible spray or an inflammable substance near the product.

- An explosion or fire may result.

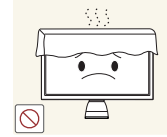

Ensure the vents are not blocked by tablecloths or curtains.

- An increased internal temperature may cause a fire.

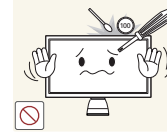

Do not insert metallic objects (chopsticks, coins, hairpins, etc) or objects that burn easily (paper, matches, etc) into the product (via the vent or input/output ports, etc).

- Be sure to power off the product and disconnect the power cable when water or other foreign substances have entered the product. Then contact Samsung Customer Service Center.
- Product failure, an electric shock or fire may result.

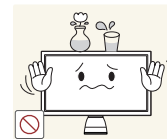

Do not place objects containing liquid (vases, pots, bottles, etc) or metallic objects on top of the product.

- Be sure to power off the product and disconnect the power cable when water or other foreign substances have entered the product. Then contact Samsung Customer Service Center.
- Product failure, an electric shock or fire may result.

Caution

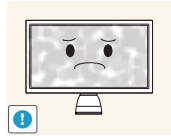

Leaving the screen fixed on a stationary image for an extended period of time may cause afterimage burn-in or defective pixels.

- If you are not going to use the product for an extended period of time, activate power-saving mode or a moving-picture screen saver.

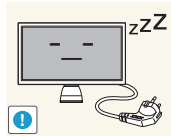

Disconnect the power cable from the power socket when not using the product for an extended period of time (vacation, etc.).

- Dust accumulation combined with heat can cause a fire, electric shock or electric leakage.



Use the product at the recommended resolution and frequency.

- Your eyesight may deteriorate.

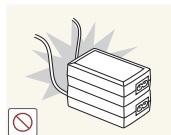

Do not put DC power adapters together.

- Otherwise, a fire may result.

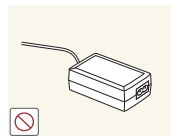

Remove the plastic bag from the DC power adapter before you use it.

- Otherwise, a fire may result.



Do not let water enter the DC power adapter or get the adapter wet.

- An electric shock or fire may result.
- Avoid using the product outdoors where it can be exposed to rain or snow.
- Take extra care to ensure the DC power adapter does not get wet when cleaning the floor with water.



Do not leave the DC power adapter near a heat source.

- Otherwise, a fire may result.

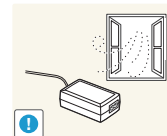

Keep the DC power adapter in a location with good ventilation.

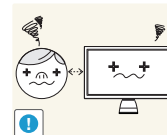

Looking at the screen too close for an extended period of time can deteriorate your eyesight.



Do not hold the product upside-down or move it by holding the stand.

- The product may fall and break or cause a personal injury.



Do not use humidifiers or stoves around the product.

- A fire or electric shock may result.

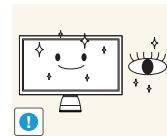

Rest your eyes for more than 5 minutes for every 1 hour of product use.

- Eye fatigue will be relieved.



Do not touch the screen when the product has been turned on for an extended period of time as it will become hot.

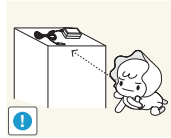

Store small accessories out of the reach of children.

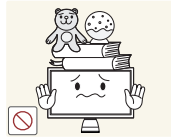

Do not place heavy objects on the product.

- Product failure or personal injury may result.

Correct posture to use the product

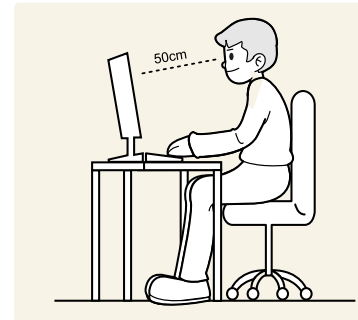

Use the product in the correct posture as follows:

- Straighten your back.
- Allow a distance of 45 to 50cm between your eye and the screen, and look slightly downward at the screen. Keep your eyes directly in front of the screen.
- Adjust the angle so light does not reflect on the screen.
- Keep your forearms perpendicular to your upper arms and level with the back of your hands.
- Keep your elbows at about a right angle.
- Adjust the height of the product so you can keep your knees bent at 90 degrees or more, your heels attached to the floor, and your arms lower than your heart.

Preparation

Checking the Contents

Removing the Packaging

⚠ The appearance of the actual product may differ from the images shown.

1. Open the packaging box. Be careful not to damage the product when you open the packaging with a sharp instrument.

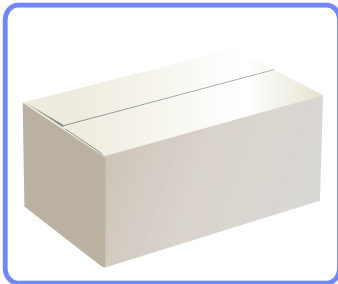

2. Remove the styrofoam from the product.

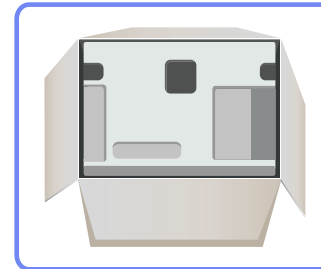

3. Check the product and remove the styrofoam and plastic bag.

NOTE

- The appearance of the actual product may differ from the image shown.
- This image is for reference only.

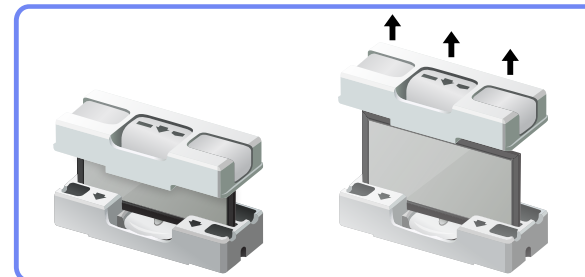

4. Store the box in a dry area so that it can be used when moving the product in the future.

Checking the Components

- ✦ Contact the vendor where you purchased the product if any components are missing.
- ✦ The appearance of the components and items sold separately may differ from the image shown.

Components

NOTE

Components may vary depending on the country.



Quick setup guide



Warranty card
(Not available in
some locations)



Natural Color Expert
Data Sheet



User manual

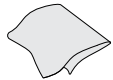

Cleaning cloth

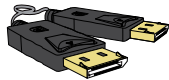

DP cable



Power cable



DC power adapter

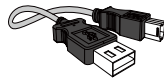

USB 2.0 cable



HDMI-MHL cable



Dual-link DVI cable

Items sold separately

NOTE

The following items can be purchased at your nearest retailer.



HDMI-DVI cable



HDMI cable

Parts

Front Buttons

- ❖ The color and shape of parts may differ from what is shown. Specifications are subject to change without notice to improve quality.
- ❖ This is a touch-type button. Tap the button lightly with a finger.
- ❖ This product contains a power circuit unit causing the stand to generate heat. The heat does not mean the product is defective.

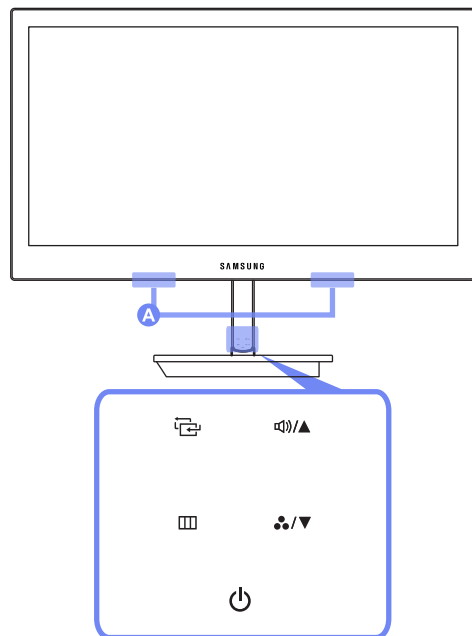

A Speakers





Icons	Description
	<p>Turn the power on or off.</p> <p>The power indicator will be lit when the product is operating normally.</p> <p>NOTE</p> <ul style="list-style-type: none"> For details on the power-saving function, refer to "Power-saving Function" in the product specifications. To reduce power consumption, it is best to remove the power cable when not using the product for an extended period of time.
	<p>This button can be used to display/exit from the OSD menu. The button can also be used to go back to the previous menu.</p> <p>To lock the OSD control, press and hold the [] button for 10 seconds.</p> <p>To unlock the OSD control, press and hold the [] button for more than 10 seconds.</p> <p>NOTE</p> <p>If the OSD control is locked,</p> <ul style="list-style-type: none"> Brightness, Contrast, Image Size can be adjusted, and INFORMATION can be viewed.
	<p>Move down to another menu item or adjust a setting when the OSD menu is displayed.</p> <p>Configure the Color Mode using the [/▼] buttons when no OSD menu is displayed.</p> <p>NOTE</p> <ul style="list-style-type: none"> For further details on Color Mode, refer to "Configuring Color Mode" in the section "Configuring the Tint Settings."
	<p>Confirm a menu selection.</p> <p>Pressing the [] button when no OSD menu is displayed will change the input source (DVI, HDMI/MHL, DisplayPort).</p> <p>NOTE</p> <p>A message that shows the current input source will appear at the top left corner of the screen each time you turn on the power or press the [] button to change the input source.</p>

Icons	Description
	<p>Move up to another menu item or adjust a setting when the OSD menu is displayed.</p> <p>When no OSD menu is displayed, the [🔊/▲] buttons can be used to adjust the Volume, Brightness or Contrast.</p> <p>NOTE</p> <ul style="list-style-type: none"> The Volume can be adjusted if the input source is DisplayPort or HDMI. The Brightness or Contrast can be adjusted if the input source is DVI. For further details on the Volume, Brightness or Contrast go to the section "INFORMATION Menu and Others" and refer to "Configuring Volume in the Initial Screen" or "Configuring Brightness and Contrast in the Initial Screen."

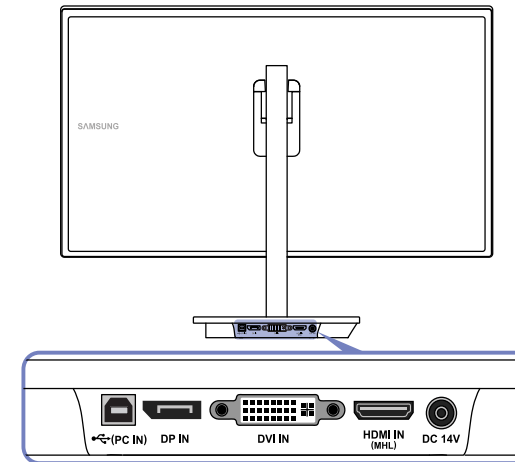
Rear View

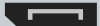
- The color and shape of parts may differ from what is shown. Specifications are subject to change without notice to improve quality.



Ports	About ports
 PC IN	Connect to a PC using a USB cable. NOTE This port can connect to a PC only.
 DP IN	Connects to a PC using a DP cable
 DVI IN	Connects to a PC via a DVI cable.
 HDMI IN (MHL)	Connect to a PC or source device using an HDMI cable. Connect to a source device that has the MHL function using the HDMI-MHL cable.
 DC 14V	Connect to a DC power adapter.

Side View

- ▣ The color and shape of parts may differ from what is shown. Specifications are subject to change without notice to improve quality.

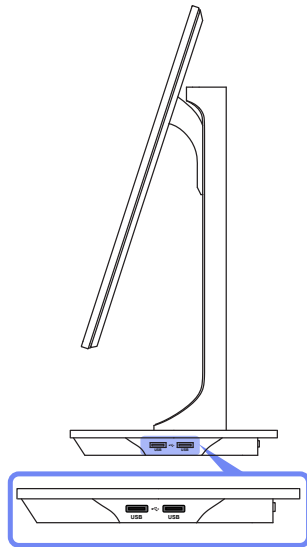

Ports	About ports
 USB ←→ USB	<p>Connect to a source device using a USB cable.</p> <p>NOTE Source devices can be charged using these USB ports.</p>

Adjusting the Product Tilt

- ▣ The color and shape of parts may differ from what is shown. Specifications are subject to change without notice to improve quality.

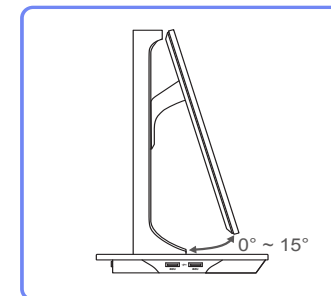
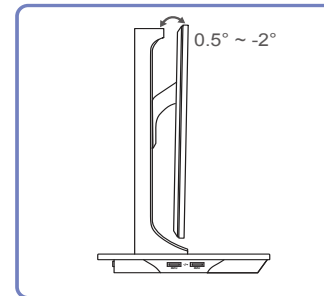

- You can adjust the product tilt.
- To avoid damage to the product when adjusting the tilt, push or pull the top area of the product at the center while holding the top of the stand.

Adjusting the Product Height

- The color and shape of parts may differ from what is shown. Specifications are subject to change without notice to improve quality.

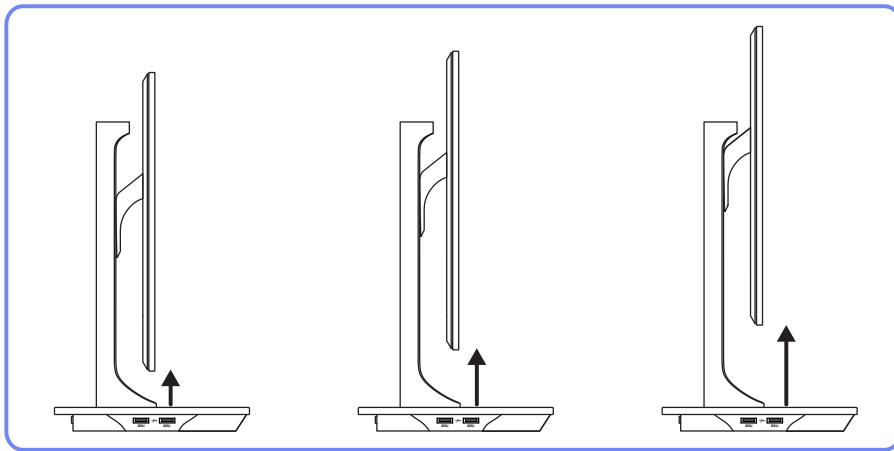

- You can adjust the product height.
- To avoid damage to the product, hold the middle of the left and right hand sides of the product when adjusting the tilt.

Using NCE (Natural Color Expert)

Configure the screen settings such as brightness and color tone.

What is Monitor Calibration?

Most of digital images are managed onscreen. That is why a monitor is very important for photographers and designers. The process to calibrate a monitor in order to display proper colors is called monitor calibration.

This product went through a calibration process using color measurement equipment in the factory before shipment.

To obtain the optimum picture quality after calibration, select "Standard" or "sRGB" mode on the monitor.

Compatible Types of Calibrators

	i1Pro series	i1Display Pro	ColorMunki Design ColorMunki Photo	CA-210 / CA-310
Manufacturer	xrite	xrite	xrite	KONICA MINOLTA
Product name	i1Photo Pro UV i1Publish Pro i1Basic Pro	i1Display Pro	ColorMunki Design ColorMunki Photo	CA-210 CA-310
Supported operating systems	Windows XP 32 & 64 Windows Vista 32 & 64 Windows 7 32 & 64	Windows XP 32 & 64 Windows Vista 32 & 64 Windows 7 32 & 64	Windows XP 32 & 64 Windows Vista 32 & 64 Windows 7 32 & 64	Windows XP 32 & 64 Windows Vista 32 & 64 Windows 7 32 & 64 Windows 2000

What is NCE (Natural Color Expert)?

The Natural Color Expert (hereinafter "NCE") program was developed by Samsung Electronics to display optimized colors customized by users.

NOTE

This product supports the monitor calibration feature through the internal NCE function and the provided NCE program.
(a calibrator can be purchased separately).

NCE Program Installation/Uninstallation

Installation

1. Insert the installation CD into the CD-ROM drive.
2. Click the **Natural Color Expert v2** installation program.

NOTE

If the software installation screen does not pop up on the main screen, go to CD-ROM → **AutoPlay** → **Manual** → **NCE** folder. Next, install using the **Natural Color Expert v2** execution file.

3. If the "**Natural Color Expert v2 InstallShield Wizard**" screen appears, click "**Next**" and "**Install**" in sequence.
4. Installation progress will be displayed.
5. Click "**Finish**" in the displayed "**InstallShield Wizard Complete**" screen.
6. The **Natural Color Expert v2** shortcut icon will be created on the desktop after installation.

NOTE

- The **Natural Color Expert v2** execution icon may not be displayed depending on the PC system or product specifications.
- Press the F5 key (**Refresh**) if the execution icon does not appear.

Uninstallation

1. Go to **Settings** → **Control Panel** on the Start menu and double-click **Add or Remove Programs**.
2. Select **Natural Color Expert v2** from the list and click **Change/Remove**.

NOTE

Natural Color Expert v2 installation can be affected by the graphics card, mother board and network conditions.

Starting NCE (Natural Color Expert)

Connecting the Calibrator

1. Connect the PC IN port on the product to a USB port on the PC using the USB cable.
2. Connect the calibrator to a USB port on the product.

NOTE

Install the driver (which is usually provided with a calibration program) provided by the calibrator manufacturer first before connecting the calibrator.

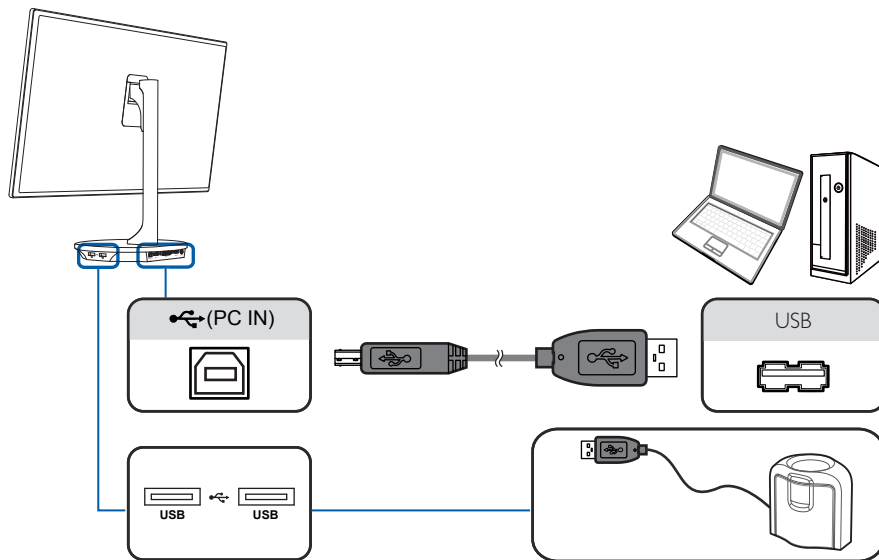

3. The connected calibrator will automatically appear in the "Select a Calibrator" screen.

NOTE

If more than one calibrator is connected, select the desired calibrator in the "Select a Calibrator" screen. Next, click "Next."

Features of the NCE Program

Layout and Menu Items on the NCE Home Screen

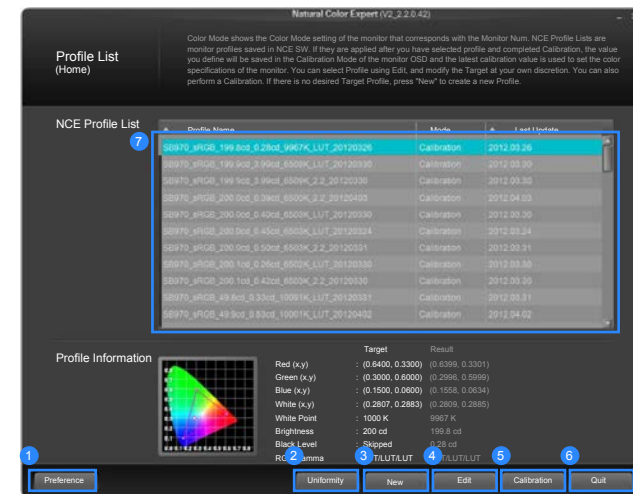

- 1 Change the custom settings for the NCE program. Measure the current settings (**COLOR, Uniformity**) of the monitor SB970.
- 2 Perform calibration for **Uniformity** to optimize the display uniformity of the monitor SB970.
- 3 Create a profile using the option "New" if a profile for the target settings is not found in the "NCE Profile List." Also, calibrate the monitor SB970 and save the changed color settings after calibration to the "NCE Profile List."
- 4 Select a profile from the "NCE Profile List" to modify the target settings as desired and perform calibration according to the modified settings.
- 5 Select a profile from the "NCE Profile List" and perform calibration according to the settings of the selected profile.
- 6 Close the program.
- 7 A profile of settings changed after calibration has been saved to the "NCE Profile List" as shown.

Profile List

This screen shows the current color settings on the monitor.

Files in the “**NCE Profile List**” are monitor profiles saved in the NCE program. If you select a profile and perform calibration, changed settings from the calibration will be saved to “**Calibration**” mode.

Layout and Menu Items on the Preference Screen

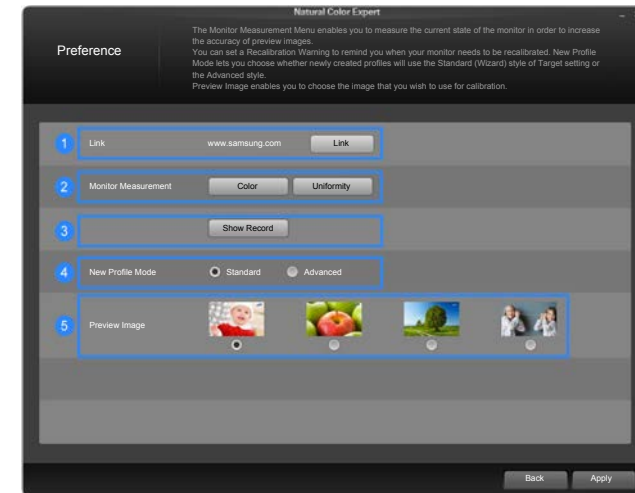

- 1 Go to the Samsung Electronics website.
- 2 Measure the current monitor settings (**COLOR, Uniformity**).
- 3 View the measurement and calibration logs by date.
- 4 Select **Standard** or **Advanced** to specify the profile mode if you have selected “**New**” in the home screen.
- 5 Configure the **Preview Image** setting if you have set **New Profile Mode** to **Standard**.

Layout and Menu Items on the Uniformity Screen

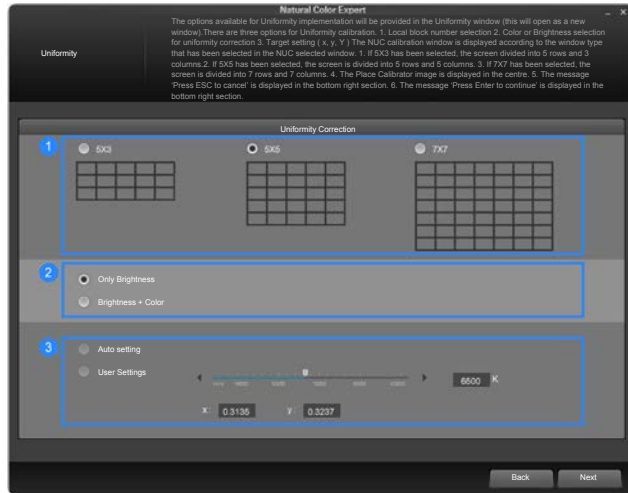

- 1 Specify the number of blocks that will be displayed on the screen when **Uniformity** calibration is carried out. A greater number of blocks will increase the precision of uniformity calibration.
- 2 Select **Only Brightness** to perform calibration only for the brightness. Select **Brightness + Color** to perform calibration for both the brightness and colors. If you select **Brightness + Color**, the color temperature uniformity will also increase from calibration.
- 3 Specify the color temperature when performing calibration. To obtain a more accurate color temperature, performing **Uniformity** calibration before color calibration is recommended.

Layout and Menu Items on the Edit Screen

If profiles exist in the "NCE Profile List," you can select a profile, modify the target settings as desired, and perform calibration according to the modified settings.

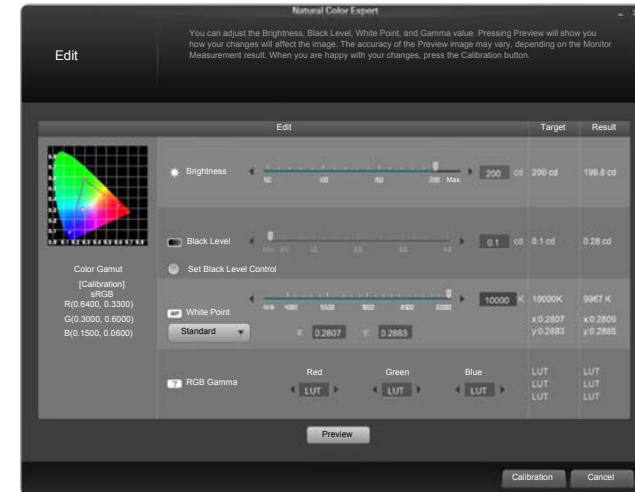

1. Select a profile from the "NCE Profile List."
2. Click the "Edit" button to change the settings.
3. After changing the settings as desired, click the "Calibration" button.

Layout and Menu Items on the Calibration Screen

If profiles exist in the "NCE Profile List," you can select a profile and perform calibration according to the settings of the selected profile.

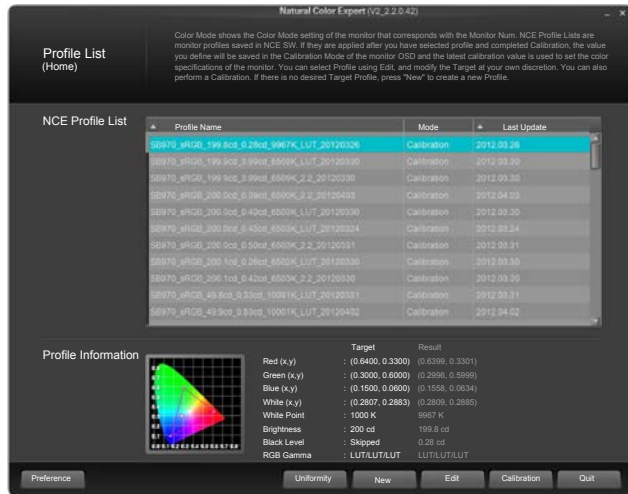

1. Select a profile from the "NCE Profile List."
2. Click the "Calibration" button to proceed with calibration according to the settings of the selected profile.

Layout and Menu Items on the New Profile Screen

As no profile exists when you use the NCE program for the first time after purchase, go to "New Profile" and create a profile.

Standard

1. Select "New Profile."

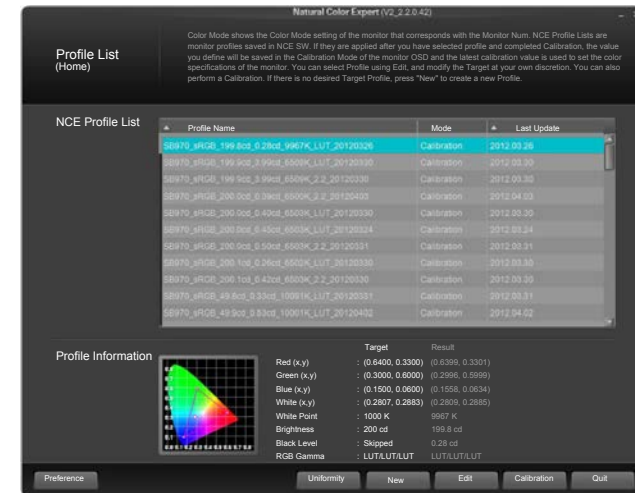

2. Specify the color gamut. (Select **sRGB** or **User Settings**.)

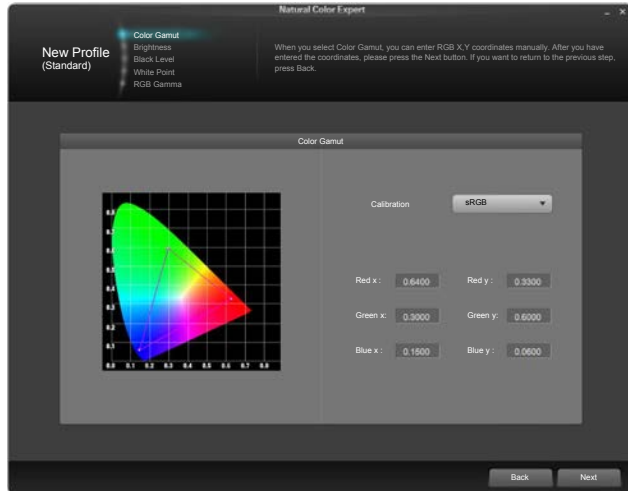

3. Configure the **Brightness**. The brightness level after calibration may depend on the color temperature.



4. Configure the **Black Level** setting. If you do not adjust the black level setting by moving the slider button, the minimum brightness will automatically be applied.

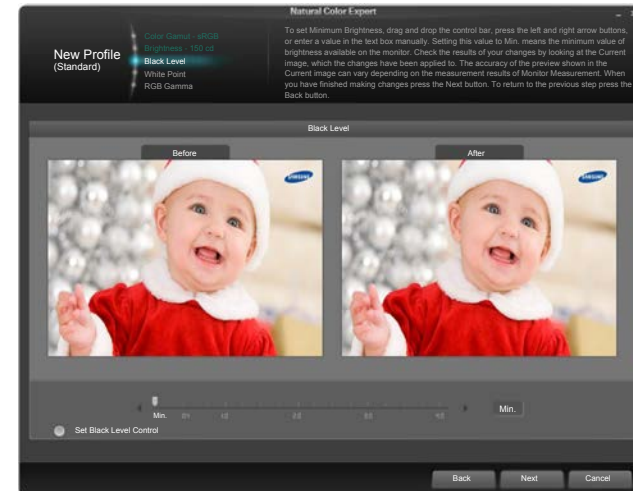

5. Configure the color temperature for **White Point** (range: 4000K – 10000K). To select a standard brightness, click the **Standard** button.



- Configure the **Gamma** settings. If you configure LUT, the gamma curve of sRGB will be applied.

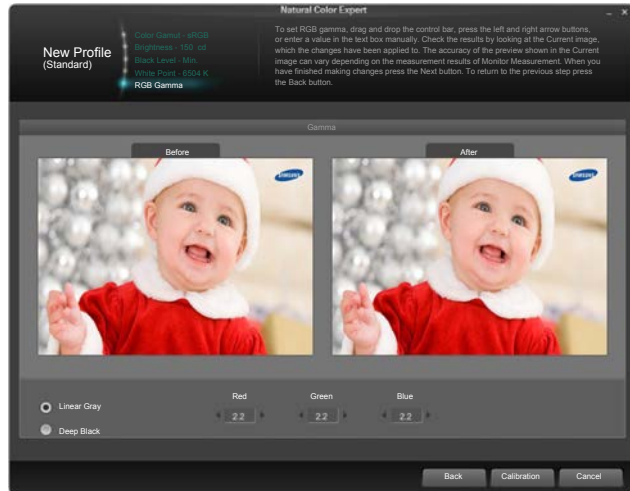

- Start calibration.



Advanced

- You can perform basic configuration using a single menu screen.

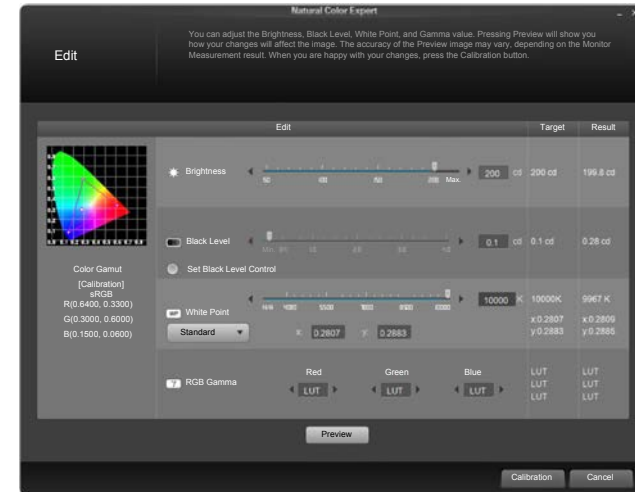

- Start calibration.



Preparing for Calibration

1. Select the connected calibrator, then click "Next."
2. If the calibrator initialization screen appears, start measurement using the calibrator.



3. Attach the calibrator to the indicated spot on the screen, then click "Next."

NOTE

- Set the screensaver time to at least 30 minutes before starting measurement.
 - The calibration process will be performed in full screen. To cancel a calibration that is in progress, press the **ESC** key.
4. Measurement will be performed.
 5. The settings for **Color Gamut**, **Brightness**, **Black Level**, **White Point**, and **RGB Gamma** can be finely adjusted.

Completing Calibration

After calibration, you can compare the screens before and after the calibration using the **After / Before** buttons.



Add or delete images as desired using the "Custom" category.

Click "Finish" to save the calibration results to **Preference** on the monitor.

Chapter. 4

Using MHL

MHL (Mobile High-Definition Link)

Connect a mobile device that supports MHL to the product and view videos and photos (saved on the device) using the product screen.

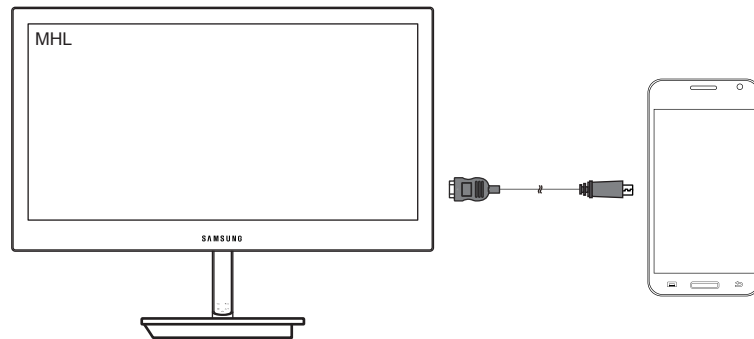

NOTE

- To use the MHL function, you need an MHL-certified mobile device. You can check if your mobile device is MHL certified on the website of the device manufacturer. To find a list of MHL-certified devices, visit the official MHL website (<http://www.mhlconsortium.org>).
- To use the MHL function, the latest version of software must be installed on the mobile device.
- On some mobile devices, the MHL function may not be available depending on the device performance or functionality.
- Since the display size of the product is larger than those of mobile devices, the picture quality may degrade.
- This product is officially MHL-certified. In the event of a problem with a mobile device connection, contact the mobile device manufacturer.
- The picture quality may degrade when content (imported from the mobile device) with a low resolution is displayed on the product.

Using MHL

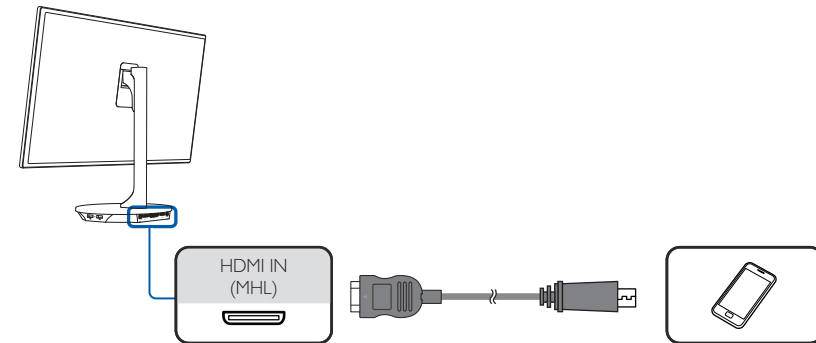

1. Connect the **HDMI IN(MHL)** port on the product to the **Micro USB** port on the mobile device using the mobile cable.
2. Connect the DC power adapter to the product and a power socket.
3. After the power is connected, the product will automatically detect and change the input source.
 - * If the input source is not set to **HDMI/MHL**, press the [>] button to change the input source.
 - * If the screen is blank in **HDMI/MHL** mode, power the product off and then on again.

NOTE

Mobile devices should be purchased separately.

4. If the following message appears, MHL mode is activated. After about 3 seconds, the MHL screen will be displayed.

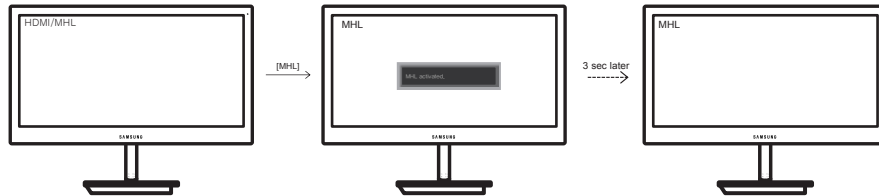

NOTE

The indicated time “after 3 seconds” may vary depending on the mobile device.

When the mobile device is in power-saving mode

If the mobile device is in power-saving mode, deactivate the power-saving mode. The MHL screen will appear normally.

When the mobile device is not connected or does not support MHL

If MHL mode does not activate, check the connection of the mobile device.

If MHL mode does not activate, check if the mobile device supports MHL.

If MHL mode does not activate even though the mobile device supports MHL, update the firmware on the device to the latest version.

Disabling MHL

When the cable is disconnected or the mobile device is powered off

If the HDMI-MHL cable is disconnected or the mobile device is powered off when MHL is active, the MHL function will be disabled.

NOTE

If the mobile cable is disconnected, HDMI/MHL mode will still be enabled.

Connecting and Using a Source Device

Checklist before Connecting to Source Devices

Check the following before you connect this product with other devices.

You can connect a camcorder, audio player or DVD player to the product.

(Note that the optimal performance can be achieved when the resolution of the source device is Full HD 1080p.)

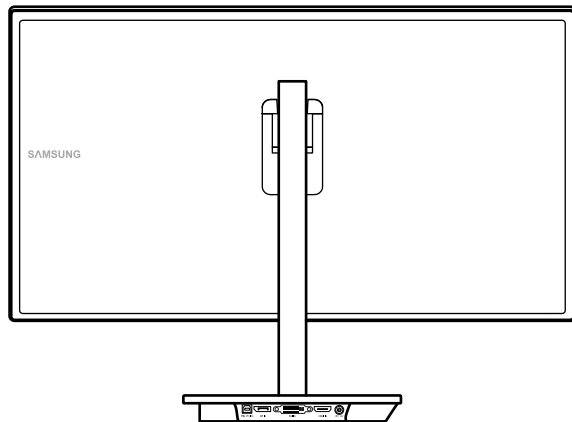

Pre-connection Checkpoints

Check the available ports on the back of the source device.

Refer to the user manual for the source device when connecting it to the product. The number and locations of ports can vary depending on the source device.

Do not connect the power cable until all connections are completed. Connecting the power cable during connection may damage the product.

Connecting the Power

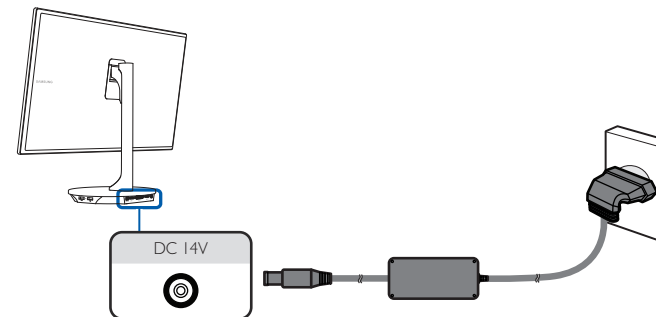

1. Connect the power cable to the DC power adapter. Next, connect the adapter to the product.

Connecting and Using a PC

Connecting to a PC

Select a connection method suitable for your PC.

✚ Connecting parts may differ in different products.

Connection Using an HDMI-DVI Cable

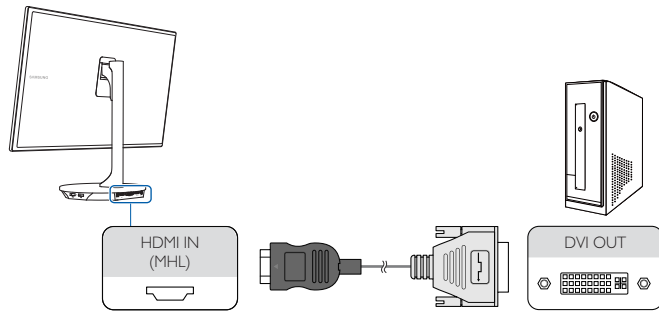

1. Connect the HDMI-DVI cable to the **HDMI IN(MHL)** port on the back of the product and the **DVI** port on the PC.
2. Connect the DC power adapter to the product and a power socket. Next, turn on the power switch on the PC.
3. Press the [⏏] button on the product to change the input source to **HDMI/MHL**.

NOTE

- Open the **SETUP&RESET** menu. Next, set **PC/AV Mode** to **PC**.
- Audio is not available if the source device is connected using an HDMI-DVI cable.

Connection Using an HDMI Cable (Digital Type)

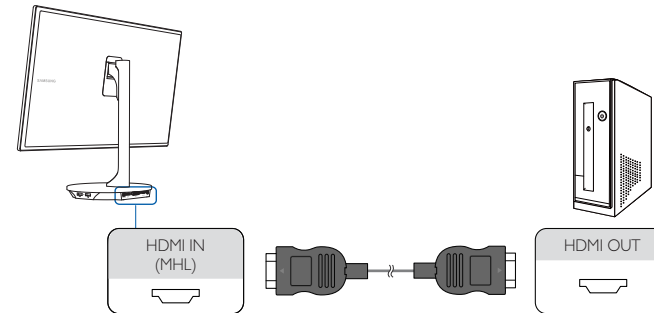

1. Connect the HDMI cable to the **HDMI IN(MHL)** port on the back of the product and the **HDMI** port on the PC.
2. Connect the DC power adapter to the product and a power socket. Next, turn on the power switch on the PC.
3. Press the [⏏] button on the product to change the input source to **HDMI/MHL**.

NOTE

- Open the **SETUP&RESET** menu. Next, set **PC/AV Mode** to **PC**.

Connection using a Dual-link DVI cable (digital type)

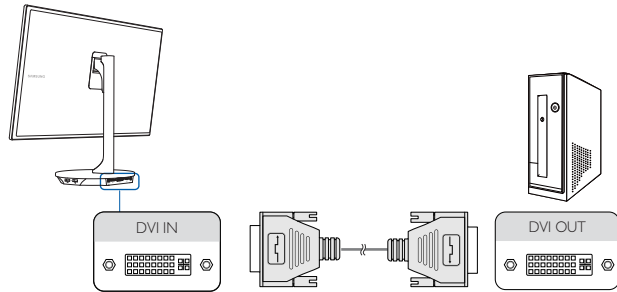

1. Connect the DVI cable to the **DVI IN** port on the back of the product and the **DVI** port on the PC.
2. Connect the DC power adapter to the product and a power socket. Next, turn on the power switch on the PC.
3. Press the [⏏] button on the product to change the input source to **DVI**.

NOTE

- Open the **SETUP&RESET** menu. Next, set **PC/AV Mode** to **PC**.
- Audio is not available if the PC and product are connected via the DVI port.

Connection Using the DP Cable

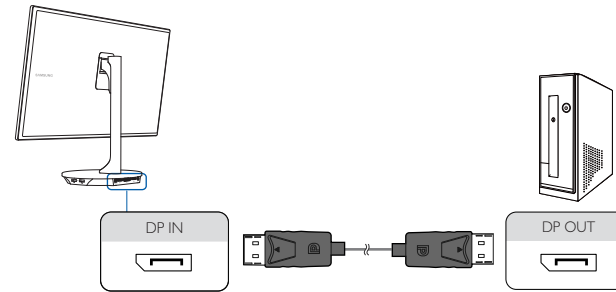

1. Connect the DP cable to the **DP IN** port on the back of the product and the **DP** port on the PC.
2. Connect the DC power adapter to the product and a power socket. Next, turn on the power switch on the PC.
3. Press [⏏] to change the input source to **DisplayPort**.

NOTE

- Open the **SETUP&RESET** menu. Next, set **PC/AV Mode** to **PC**.

Connecting the Product to a PC as a USB HUB

NOTE

The product can function as a HUB by connecting to a PC via a USB cable. You can connect a source device directly to the product and control the device from the product, without having to connect the device to the PC.

1. Connect the USB cable to **PC IN** on the back of the product and **USB** on the PC.
2. Using the product as a hub, connect and use various source devices with the product at the same time.
 - A PC cannot connect to multiple source devices at the same time as it has a limited number of input/output ports available. The HUB feature on the product will improve your work efficiency by allowing you to connect multiple source devices to the USB ports on the product at the same time without connecting them to a PC.
 - If source devices are connected to the PC, the numerous cables around the PC can get tangled and look messy. Connecting them directly to the product will resolve this.

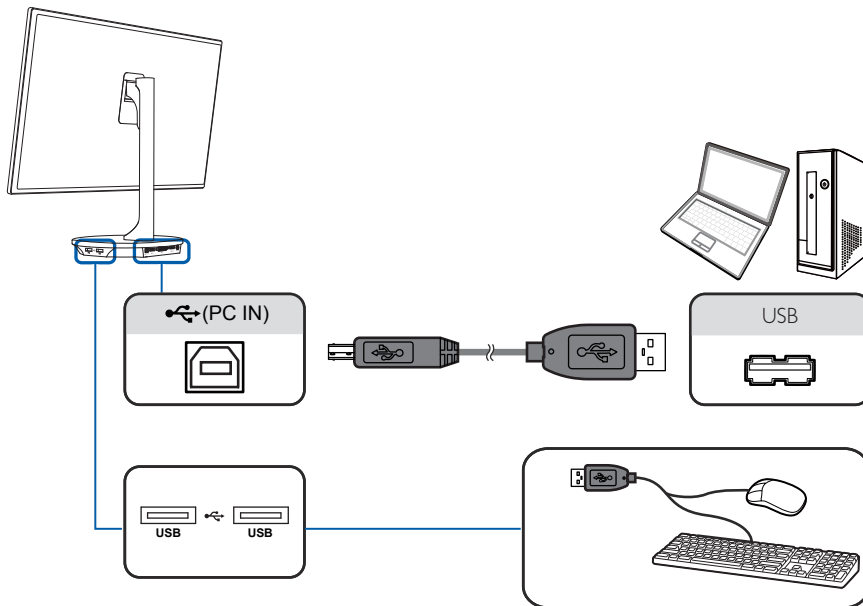

NOTE

- An external mass-storage HDD requires external power supply. Be sure to connect it to a power source.

Driver Installation

NOTE

- You can set the optimum resolution and frequency for this product by installing the corresponding drivers.
 - An installation driver is contained on the CD supplied with the product.
 - If the provided file is faulty, visit the Samsung Electronics homepage (<http://www.samsung.com>) and download the file.
1. Insert the user manual CD provided with the product into the CD-ROM drive.
 2. Click "Windows Driver."
 3. Follow the instructions given on the screen to proceed with installation.
 4. Select your product model from the list of models.

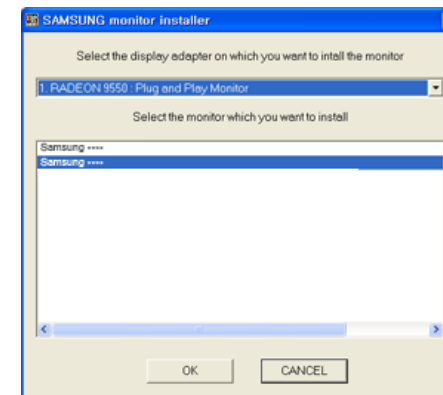

5. Go to Display Properties and check that the resolution and refresh rate are appropriate. Refer to your Windows OS manual for further details.

Setting Optimum Resolution

An information message about setting optimum resolution will appear if you power on the product for the first time after purchase.

Select a language and change the resolution to the optimum value.

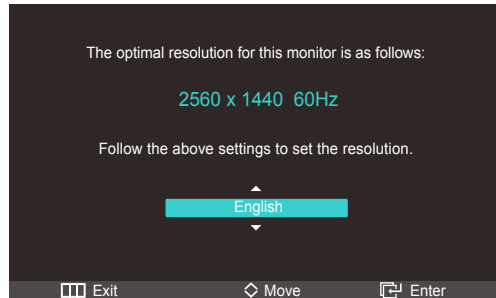

1. Press [F4]/[▲], [F5]/[▼] to move to the language you want and press [Enter].
2. To hide the information message, press [Esc].

NOTE

- If the optimal resolution is not selected, the message will appear up to three times for a specified time even after the product is turned off and on again.
- The resolution can also be changed to the optimal setting (1920 x 1080) using Control Panel on your PC.

Changing the Resolution Using a PC

NOTE

Adjust the resolution and refresh rate in Control Panel on your PC to obtain optimum picture quality.

The picture quality of TFT-LCDs may degrade if the optimum resolution is not selected.

Changing the Resolution on Windows XP

Go to **Control Panel** → **Display** → **Settings** and change the resolution.

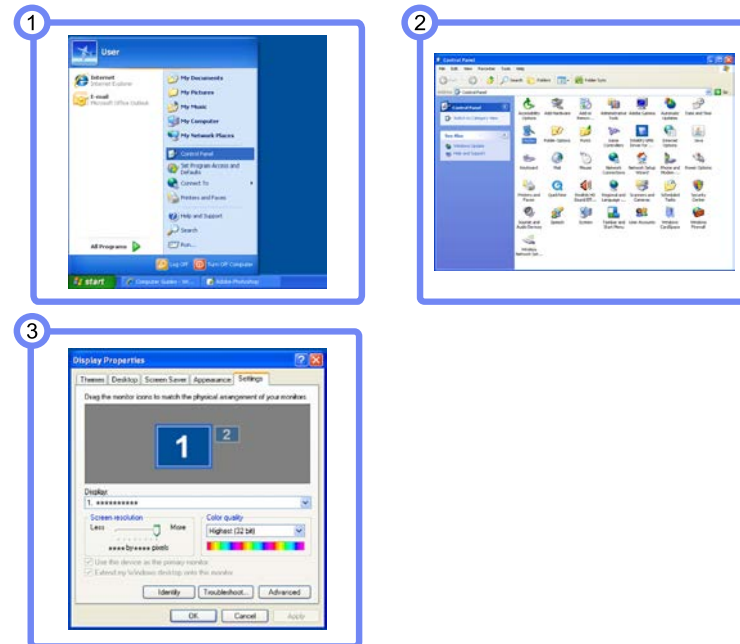

Changing the Resolution on Windows Vista

Go to **Control Panel** → **Personalization** → **Display Settings** and change the resolution.

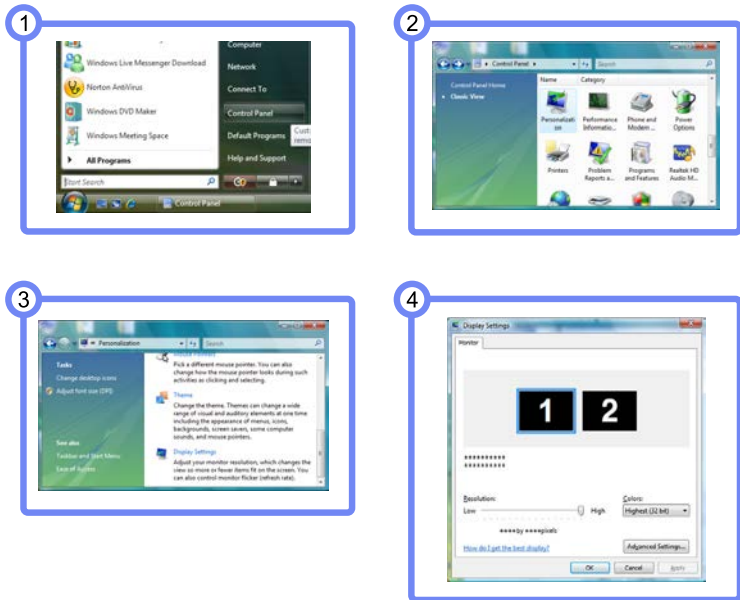

Changing the Resolution on Windows 7

Go to **Control Panel** → **Display** → **Screen Resolution** and change the resolution.

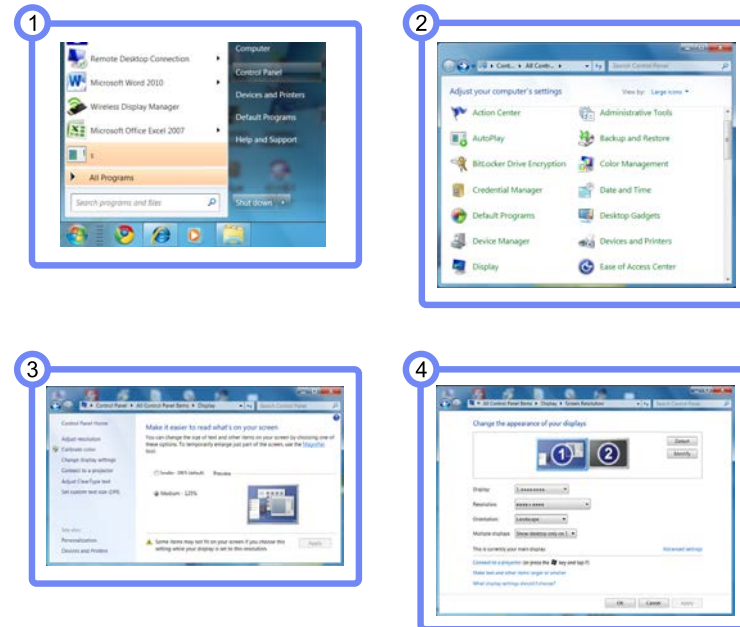



Connecting to a Video Device

The product can be connected to a video device.

✚ Connecting parts may differ in different products.

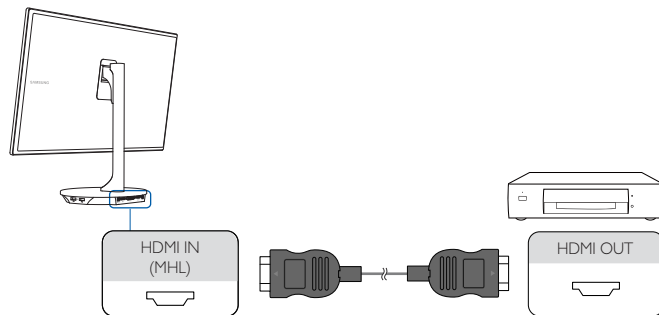
Connection Using an HDMI Cable



1. Connect the HDMI cable to the **HDMI IN(MHL)** port on the product and the **HDMI** port on the video device.
2. Press the  button on the product to change the input source to **HDMI/MHL**.

NOTE

- Open the **SETUP&RESET** menu. Next, set **PC/AV Mode** to **AV**.

Screen Setup

Configure the screen settings such as brightness and color tone.

Dynamic Contrast

Dynamic Contrast automatically adjusts the picture contrast to maintain a balance of bright and dark areas.

Changing the Dynamic Contrast Setting

1. Press [MENU] on the product.
2. Move to **PICTURE** using the [RIGHT]/[▲], [LEFT]/[▼] buttons. Next, press the [ENTER] button.
3. Press [RIGHT]/[▲], [LEFT]/[▼] to move to **Dynamic Contrast** and press [ENTER]. The following screen will appear.

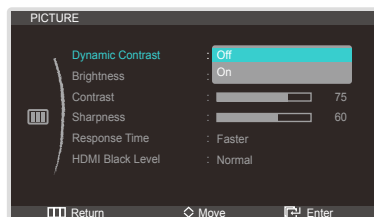

- Off - On

4. Move to the desired option using the [RIGHT]/[▲], [LEFT]/[▼] buttons. Next, press the [ENTER] button.
5. The selected option will be applied.

Brightness

You can adjust the general brightness of the picture. (Range: 0~100)

A higher value will make the picture appear brighter.

NOTE

This option is enabled if **Dynamic Contrast** is set to **Off**.

Configuring Brightness

1. Press [MENU] on the product.
2. Move to **PICTURE** using the [RIGHT]/[▲], [LEFT]/[▼] buttons. Next, press the [ENTER] button.
3. Move to **Brightness** using the [RIGHT]/[▲], [LEFT]/[▼] buttons. Next, press the [ENTER] button. The following screen will appear.

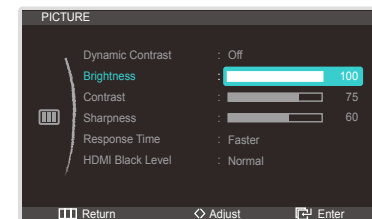

4. Adjust the **Brightness** setting using the [RIGHT]/[▲], [LEFT]/[▼] buttons.

Contrast

Adjust the contrast between the objects and background. (Range: 0~100)

A higher value will increase the contrast to make the object appear clearer.

NOTE

This option is enabled if **Dynamic Contrast** is set to **Off**.

Configuring Contrast

1. Press [MENU] on the product.
2. Move to **PICTURE** using the [RIGHT]/[▲], [HOME]/[▼] buttons. Next, press the [ENTER] button.
3. Move to **Contrast** using the [RIGHT]/[▲], [HOME]/[▼] buttons. Next, press the [ENTER] button. The following screen will appear.

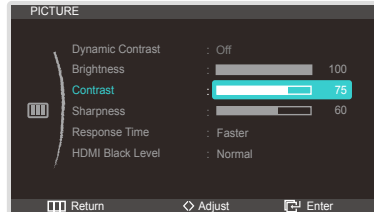

4. Adjust the **Contrast** setting using the [RIGHT]/[▲], [HOME]/[▼] buttons.

Sharpness

Make the outline of objects more clear or blurry. (Range: 0~100)

A higher value will make the outline of objects clearer.

NOTE

This option is enabled if **Dynamic Contrast** is set to **Off**.

Configuring Sharpness

1. Press [MENU] on the product.
2. Move to **PICTURE** using the [RIGHT]/[▲], [HOME]/[▼] buttons. Next, press the [ENTER] button.
3. Move to **Sharpness** using the [RIGHT]/[▲], [HOME]/[▼] buttons. Next, press the [ENTER] button. The following screen will appear.

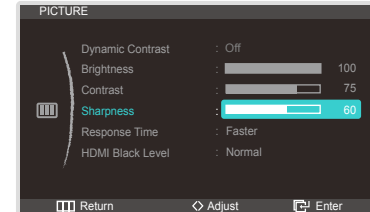

4. Adjust the **Sharpness** setting using the [RIGHT]/[▲], [HOME]/[▼] buttons.

Response Time

Accelerate the panel response rate to make video appear more vivid and natural.

NOTE

- It is recommended to set the response rate to **Normal** or **Faster** when you are not viewing a video.
- The functions available may vary depending on the product model. Refer to the actual product.

Configuring Response Time

1. Press [MENU] on the product.
2. Move to **PICTURE** using the [RIGHT]/[▲], [LEFT]/[▼] buttons. Next, press the [ENTER] button.
3. Move to **Response Time** using the [RIGHT]/[▲], [LEFT]/[▼] buttons. Next, press the [ENTER] button. The following screen will appear.

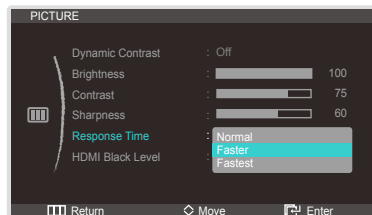

- **Normal** - **Faster** - **Fastest**
4. Move to the desired option using the [RIGHT]/[▲], [LEFT]/[▼] buttons. Next, press the [ENTER] button.
 5. The selected option will be applied.

HDMI Black Level

If you connect a DVD player or set-top box to the product using an **HDMI** cable, the contrast and color may degrade making the picture look darker. If this is the case, correct the degraded picture quality using the **HDMI Black Level** menu.

Configuring HDMI Black Level

1. Press [MENU] on the product.
2. Move to **PICTURE** using the [RIGHT]/[▲], [LEFT]/[▼] buttons. Next, press the [ENTER] button.
3. Move to **HDMI Black Level** using the [RIGHT]/[▲], [LEFT]/[▼] buttons. Next, press the [ENTER] button. The following screen will appear.

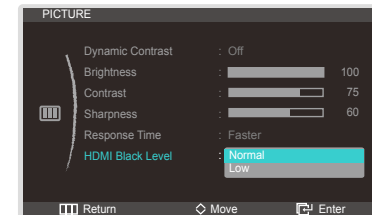

- **Normal**: Set the brightness of the darkest parts of the screen to be normal.
 - **Low**: Set the brightness of the darkest parts of the screen to be darker than Normal mode.
4. Move to the desired option using the [RIGHT]/[▲], [LEFT]/[▼] buttons. Next, press the [ENTER] button.
 5. The selected option will be applied.

NOTE

- Available only when the product is connected to a source device using an HDMI cable.
- The **HDMI Black Level** function may not be compatible with some source devices.

Configuring the Tint Settings

Adjust the tint of the screen. Adjust the tint of the screen.

Color Mode

NOTE

This option is enabled if **Dynamic Contrast** is set to **Off**.

Configuring Color Mode

1. Press [MENU] on the product.
2. Move to **COLOR** using the [RIGHT]/▲, [DOWN]/▼ buttons. Next, press the [ENTER] button.
3. Move to **Color Mode** using the [RIGHT]/▲, [DOWN]/▼ buttons. Next, press the [ENTER] button. The following screen will appear.

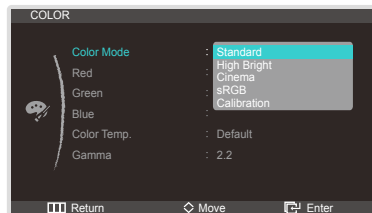

- **Standard:** Some users may not find the brightness and sharpness comfortable for their eyes in this mode. If this is the case, adjust the brightness and sharpness.
 - When **Color Mode** is set to **Standard**, the default mode for **Color Temp.** is set to **Default**.
 - If changing the settings for **Red**, **Green**, and **Blue**, the mode of **Color Temp.** will change to **Custom**.

- **High Bright:** Increase the brightness more than when in **Cinema** and **sRGB** modes.
 - **Cinema:** This mode is suitable to view entertainment content (video, DVD, etc.) providing a bright and sharp picture.
 - **sRGB:** Change the color system to **sRGB** mode.
 - **Calibration:** This mode analyzes the color characteristics of your monitor and allows you to save color information of the monitor as an ICC profile. This will tell your monitor what color space it should use and how it should interpret and display colors. Optimized color from the **Natural Color Expert** program and **Calibration** will be displayed on the screen.
 - When **Color Mode** is set to **Calibration**, all the options of the color settings menu will be disabled.
4. Move to the desired option using the [RIGHT]/▲, [DOWN]/▼ buttons. Next, press the [ENTER] button.
 5. The selected option will be applied.

Red

Adjust the value of the color red in the picture. (Range: 0~100)

A higher value will increase the intensity of the color.

Configuring Red

1. Press [MENU] on the product.
2. Move to **COLOR** using the [RIGHT]/▲, [●●/▼] buttons. Next, press the [ENTER] button.
3. Move to **Red** using the [RIGHT]/▲, [●●/▼] buttons. Next, press the [ENTER] button.
The following screen will appear.

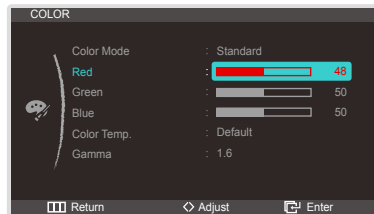

4. Adjust the **Red** setting using the [RIGHT]/▲, [●●/▼] buttons.

Green

Adjust the value of the color green in the picture. (Range: 0~100)

A higher value will increase the intensity of the color.

Configuring Green

1. Press [MENU] on the product.
2. Move to **COLOR** using the [RIGHT]/▲, [●●/▼] buttons. Next, press the [ENTER] button.
3. Move to **Green** using the [RIGHT]/▲, [●●/▼] buttons. Next, press the [ENTER] button.
The following screen will appear.

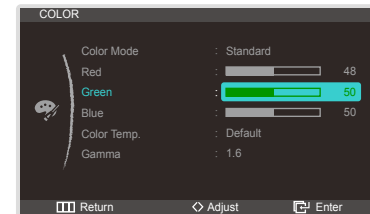

4. Adjust the **Green** setting using the [RIGHT]/▲, [●●/▼] buttons.

Blue

Adjust the value of the color blue in the picture. (Range: 0~100)

A higher value will increase the intensity of the color.

Configuring Blue

1. Press [MENU] on the product.
2. Move to **COLOR** using the [RIGHT]/[▲], [●]/[▼] buttons. Next, press the [ENTER] button.
3. Move to **Blue** using the [RIGHT]/[▲], [●]/[▼] buttons. Next, press the [ENTER] button. The following screen will appear.

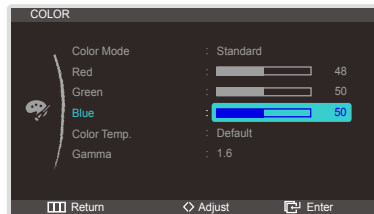

4. Adjust the **Blue** setting using the [RIGHT]/[▲], [●]/[▼] buttons.

Color Temp.

Configuring Color Temp.

1. Press [MENU] on the product.
2. Move to **COLOR** using the [RIGHT]/[▲], [●]/[▼] buttons. Next, press the [ENTER] button.
3. Press [RIGHT]/[▲], [●]/[▼] to move to **Color Temp.** and press [ENTER] on the product. The following screen will appear.

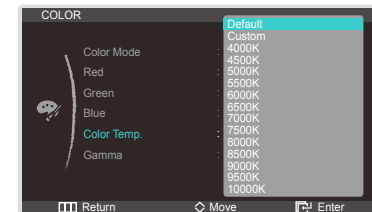

- Default
- Custom
- 4000K - 10000K

NOTE

The available modes for **Color Temp.** depend on the setting of **Color Mode**.

4. Move to the desired option using the [RIGHT]/[▲], [●]/[▼] buttons. Next, press the [ENTER] button.
5. The selected option will be applied.

Gamma

Adjust the mid-range brightness (Gamma) of the picture.

Configuring Gamma

1. Press [MENU] on the product.
2. Move to **COLOR** using the [F1]/▲, [F2]/▼ buttons. Next, press the [ENTER] button.
3. Move to **Gamma** using the [F1]/▲, [F2]/▼ buttons. Next, press the [ENTER] button.
The following screen will appear.

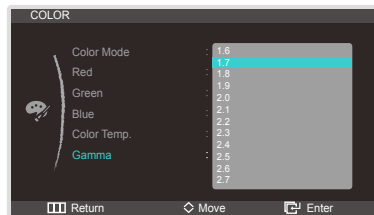

4. Move to the desired option using the [F1]/▲, [F2]/▼ buttons. Next, press the [ENTER] button.
5. The selected option will be applied.

Resizing or Relocating the Screen

Image Size

Change the picture size.

NOTE

The available **Image Size** menu options depend on the setting of "PC/AV Mode" under **SETUP&RESET**.

Configuring Image Size

1. Press [MENU] on the product.
2. Move to **SIZE&POSITION** using the [F1]/[▲], [F2]/[▼] buttons. Next, press the [F3] button.
3. Move to **Image Size** using the [F1]/[▲], [F2]/[▼] buttons. Next, press the [F3] button. The following screen will appear.

In PC mode

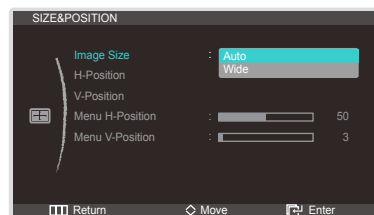

- **Auto**: Display the picture according to the aspect ratio of the input source.
- **Wide**: Stretch the picture to full screen regardless of the aspect ratio of the input source.

In AV mode



- **4:3**: This mode is suitable to view the 4:3 aspect ratio picture of video content or standard broadcasts.
- **16:9**: This mode is suitable to view the 16:9 aspect ratio picture of DVD content or widescreen broadcasts.
- **Screen Fit**: This mode displays input without truncating the original picture.

NOTE

- Adjusting the **H-Position** and **V-Position** settings is possible if **Image Size** is set to **Screen Fit**.
4. Move to the desired option using the [F1]/[▲], [F2]/[▼] buttons. Next, press the [F3] button.
 5. The selected option will be applied.

H-Position

Move the screen to the left or right.

NOTE

Adjusting the H-Position and V-Position settings is possible if Image Size is set to Screen Fit.

Configuring H-Position

1. Press [MENU] on the product.
2. Move to **SIZE&POSITION** using the [F1]/▲, [F2]/▼ buttons. Next, press the [F3] button.
3. Move to **H-Position** using the [F1]/▲, [F2]/▼ buttons. Next, press the [F3] button. The following screen will appear.

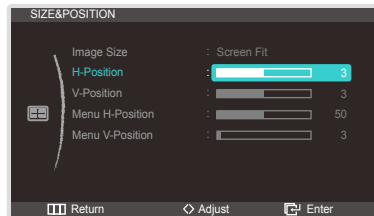

- Adjusting the H-Position and V-Position settings is possible if Image Size is set to Screen Fit.
4. Adjust the H-Position setting using the [F1]/▲, [F2]/▼ buttons.

V-Position

Move the screen up or down.

NOTE

Adjusting the H-Position and V-Position settings is possible if Image Size is set to Screen Fit.

Configuring V-Position

1. Press [MENU] on the product.
2. Move to **SIZE&POSITION** using the [F1]/▲, [F2]/▼ buttons. Next, press the [F3] button.
3. Move to **V-Position** using the [F1]/▲, [F2]/▼ buttons. Next, press the [F3] button. The following screen will appear.



- Adjusting the H-Position and V-Position settings is possible if Image Size is set to Screen Fit.
4. Adjust the V-Position setting using the [F1]/▲, [F2]/▼ buttons.

Menu H-Position

Move the menu position to the left or right.

Configuring Menu H-Position

1. Press [□□□] on the product.
2. Move to **SIZE&POSITION** using the [⏪]/▲, [●●/▼] buttons. Next, press the [⏪] button.
3. Move to **Menu H-Position** using the [⏪]/▲, [●●/▼] buttons. Next, press the [⏪] button. The following screen will appear.

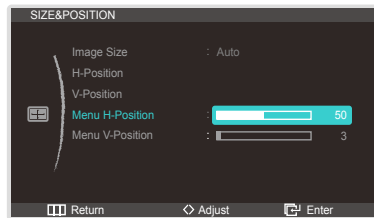

4. Adjust the **Menu H-Position** setting using the [⏪]/▲, [●●/▼] buttons.

Menu V-Position

Move the menu position up or down.

Configuring Menu V-Position

1. Press [□□□] on the product.
2. Move to **SIZE&POSITION** using the [⏪]/▲, [●●/▼] buttons. Next, press the [⏪] button.
3. Move to **Menu V-Position** using the [⏪]/▲, [●●/▼] buttons. Next, press the [⏪] button. The following screen will appear.

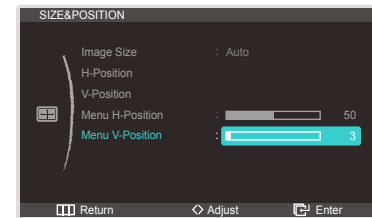

4. Adjust the **Menu V-Position** setting using the [⏪]/▲, [●●/▼] buttons.

Setup and Reset

Eco Saving

Adjust the power consumption of the product to save energy.

Configuring Eco Saving

1. Press [F10] on the product.
2. Move to **SETUP&RESET** using the [F11]/▲, [F12]/▼ buttons.
Next, press the [F13] button.
3. Move to **Eco Saving** using the [F11]/▲, [F12]/▼ buttons.
Next, press the [F13] button.
The following screen will appear.

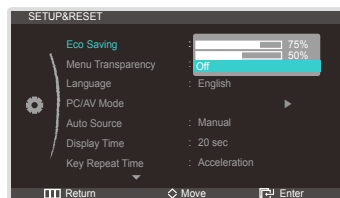

- 75%: Reduce the power consumption of the product to 75%.
 - 50%: Reduce the power consumption of the product to 50%.
 - Off: Disable Eco Saving.
4. Move to the desired option using the [F11]/▲, [F12]/▼ buttons.
Next, press the [F13] button.
 5. The selected option will be applied.

Menu Transparency

Configure the transparency for the menu windows.

Configuring Menu Transparency

1. Press [F10] on the product.
2. Move to **SETUP&RESET** using the [F11]/▲, [F12]/▼ buttons.
Next, press the [F13] button.
3. Move to **Menu Transparency** using the [F11]/▲, [F12]/▼ buttons.
Next, press the [F13] button.
The following screen will appear.

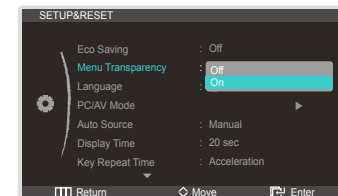

4. Move to the desired option using the [F11]/▲, [F12]/▼ buttons.
Next, press the [F13] button.
5. The selected option will be applied.

Language

Set the menu language.

NOTE

- A change to the language setting will only be applied to the onscreen menu display.
- It will not be applied to other functions on your PC.

Configuring Language

1. Press [M] on the product.
2. Move to **SETUP&RESET** using the [F4]/▲, [F5]/▼ buttons.
Next, press the [Enter] button.
3. Move to **Language** using the [F4]/▲, [F5]/▼ buttons.
Next, press the [Enter] button.
The following screen will appear.

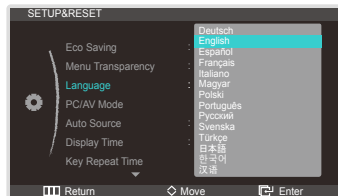

4. Move to the desired option using the [F4]/▲, [F5]/▼ buttons.
Next, press the [Enter] button.
5. The selected option will be applied.

PC/AV Mode

Set **PC/AV Mode** to **AV**. The size of the image displayed on the screen will be enlarged.
This option is useful when viewing a movie.

Configuring PC/AV Mode

1. Press [M] on the product.
2. Move to **SETUP&RESET** using the [F4]/▲, [F5]/▼ buttons.
Next, press the [Enter] button.
3. Move to **PC/AV Mode** using the [F4]/▲, [F5]/▼ buttons.
Next, press the [Enter] button.
The following screen will appear.

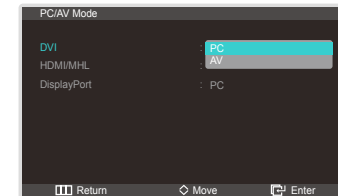

4. Move to the desired option using the [F4]/▲, [F5]/▼ buttons.
Next, press the [Enter] button.
5. The selected option will be applied.

Auto Source

Enable/disable **Auto Source** mode that detects the input source automatically.

Configuring Auto Source

1. Press [F4] on the product.
2. Move to **SETUP&RESET** using the [F4]/▲, [F5]/▼ buttons.
Next, press the [F6] button.
3. Move to **Auto Source** using the [F4]/▲, [F5]/▼ buttons.
Next, press the [F6] button.
The following screen will appear.

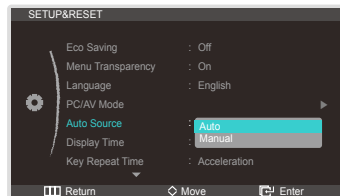

- **Auto:** Automatically detect the input source.
 - **Manual:** Manually select an input source.
4. Move to the desired option using the [F4]/▲, [F5]/▼ buttons.
Next, press the [F6] button.
 5. The selected option will be applied.

Display Time

Set the on-screen display (OSD) menu to automatically disappear if the menu is not used for a specified period of time.

Display Time can be used to set the time after which you want the OSD menu to disappear automatically.

Configuring Display Time

1. Press [F4] on the product.
2. Move to **SETUP&RESET** using the [F4]/▲, [F5]/▼ buttons.
Next, press the [F6] button.
3. Move to **Display Time** using the [F4]/▲, [F5]/▼ buttons.
Next, press the [F6] button.
The following screen will appear.

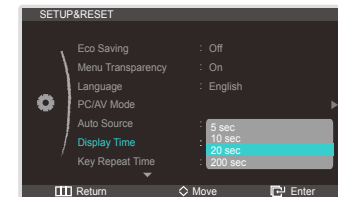

- 5 sec - 10 sec - 20 sec - 200 sec
4. Move to the desired option using the [F4]/▲, [F5]/▼ buttons.
Next, press the [F6] button.
 5. The selected option will be applied.

Key Repeat Time

Control the response rate of a button when the button is pressed.

Configuring Key Repeat Time

1. Press [||||] on the product.
2. Move to **SETUP&RESET** using the [⏪]/▲], [⏩]/▼] buttons.
Next, press the [⏪] button.
3. Move to **Key Repeat Time** using the [⏪]/▲], [⏩]/▼] buttons.
Next, press the [⏪] button.
The following screen will appear.

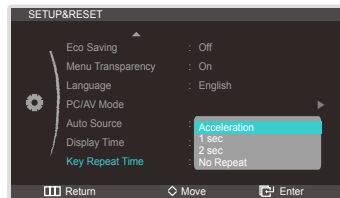

- The available options include **Acceleration**, **1 sec**, and **2 sec**. If **No Repeat** is selected, a button will respond only when it is pressed.
4. Move to the desired option using the [⏪]/▲], [⏩]/▼] buttons.
Next, press the [⏪] button.
 5. The selected option will be applied.

Off Timer On/Off

You can set the product to automatically turn off.

Configuring Off Timer On/Off

1. Press [||||] on the product.
2. Move to **SETUP&RESET** using the [⏪]/▲], [⏩]/▼] buttons.
Next, press the [⏪] button.
3. Move to **Off Timer On/Off** using the [⏪]/▲], [⏩]/▼] buttons.
Next, press the [⏪] button.
The following screen will appear.

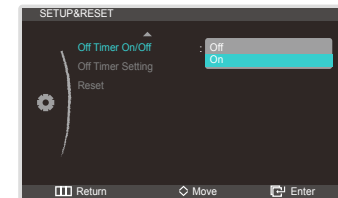

- **Off**: Deactivate the off timer so that the product does not power off automatically.
 - **On**: Activate the off timer so that the product powers off automatically.
4. Move to the desired option using the [⏪]/▲], [⏩]/▼] buttons.
Next, press the [⏪] button.
 5. The selected option will be applied.

Off Timer Setting

The off timer can be set within a range of 1 to 23 hours. The product will automatically power off after the specified number of hours.

NOTE

Available only when **Off Timer On/Off** is set to **On**.

Configuring Off Timer Setting

1. Press [||||] on the product.
2. Move to **SETUP&RESET** using the [↶]/▲, [●]/▼ buttons.
Next, press the [↵] button.
3. Move to **Off Timer Setting** using the [↶]/▲, [●]/▼ buttons.
Next, press the [↵] button. The following screen will appear.

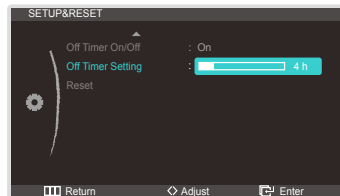

4. Configure the **Off Timer Setting** using the [↶]/▲, [●]/▼ buttons.

Reset

Return all the settings for the product to the default factory settings.

Restoring the default settings (Reset)

1. Press [||||] on the product.
2. Move to **SETUP&RESET** using the [↶]/▲, [●]/▼ buttons.
Next, press the [↵] button.
3. Move to **Reset** using the [↶]/▲, [●]/▼ buttons.
Next, press the [↵] button.
The following screen will appear.

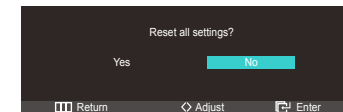

4. Move to the desired option using the [↶]/▲, [●]/▼ buttons.
Next, press the [↵] button.
5. The selected option will be applied.

INFORMATION Menu and Others

INFORMATION

View the current input source, frequency and resolution.

Viewing information (INFORMATION)

1. Press [MENU] on the product.
2. Move to **INFORMATION** using the [RIGHT]/[UP], [LEFT]/[DOWN] buttons. The current input source, frequency and resolution will appear.

HDMI

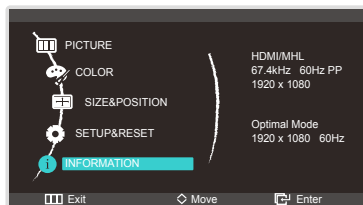

DVI

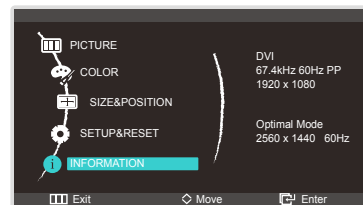

DisplayPort

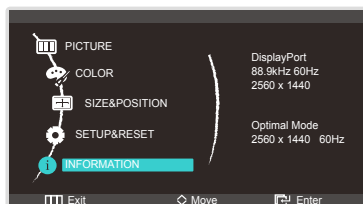

Configuring Color Mode in the Initial Screen

Configure the **Color Mode** using the [LEFT]/[DOWN] buttons when no OSD menu is displayed.

1. Press [LEFT]/[DOWN] when the initial screen is displayed. The following screen will appear.
2. Adjust the **Color Mode** setting using the [RIGHT]/[UP], [LEFT]/[DOWN] buttons.

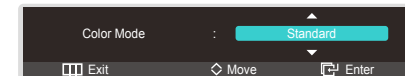

- Standard - High Bright - Cinema - sRGB - Calibration

Configuring Volume in the Initial Screen

NOTE

Available only when the input source is **DisplayPort** or **HDMI**.

Adjust the **Volume** using the [F4]/▲ buttons when the initial screen (that displays no menu screen) is displayed.

1. Press [F4]/▲ when the initial screen is displayed. The following screen will appear.



2. Adjust the **Volume** setting using the [F4]/▲, [F5]/▼ buttons.

Configuring Brightness and Contrast in the Initial Screen

NOTE

Available only when the input source is **DVI**.

Adjust the **Brightness** or **Contrast** using the [F4]/▲ buttons when the initial screen (that displays no menu screen) is displayed.

1. Press [F4]/▲ when the initial screen is displayed. The following screen will appear.



2. Adjust the **Brightness** and **Contrast** setting using the [F4]/▲, [F5]/▼ buttons.

Troubleshooting Guide

Requirements Before Contacting Samsung Customer Service Center

- Before calling Samsung Customer Service Center, test your product as follows.
If the problem persists, contact Samsung Customer Service Center.

Testing the Product

Check if your product is operating normally by using the product test function.

If the screen is turned off and the power indicator blinks even though the product is properly connected to a PC, perform a self-diagnosis test.

1. Power off both the PC and product.
2. Disconnect the cables from the product.
3. Power on the product.
4. If the message "Check Signal Cable" appears, the product is working normally.

NOTE

If the screen remains blank, check the PC system, video controller and cable.

Checking the Resolution and Frequency

For a mode that exceeds the supported resolution (refer to "Preset Timing Modes"), the message **Not Optimum Mode** will appear repeatedly.

Check the following.

Installation issue (PC mode)

Troubleshooting	Solutions
The screen keeps switching on and off.	Check that the cables are properly connected between the product and PC and that the connectors are firmly locked.

Screen issue

Troubleshooting	Solutions
The power LED is off. The screen will not switch on.	Make sure that the power cable is connected.
The message "Check Signal Cable" appears.	Check that the cable is properly connected to the product. Check that the device connected to the product is powered on.

Troubleshooting	Solutions
The message "Not Optimum Mode." appears on the screen.	This message appears when the signal from the graphics card exceeds the maximum resolution or frequency for the product. Set the maximum resolution and frequency according to the product specifications referring to the Standard Signal Mode Table.
The images on the screen look distorted.	Check the cable connection to the product
The screen is not clear. The screen is blurry.	Remove components (video cable, etc.) and try again. Set the resolution and frequency to the recommended level.
The screen appears unstable and shaky.	Check that the resolution and frequency of the PC and graphics card are set within a range compatible with the product. Then, change the screen settings if required by referring to the additional information on the product menu.
There are shadows or ghost images left on the screen.	
The screen is too bright. The screen is too dark.	Adjust the Brightness setting.
Screen color is inconsistent.	Adjust the COLOR settings.
The colors on the screen have a shadow and are distorted.	Adjust the COLOR settings.
White does not really look white.	Adjust the COLOR settings.
There is no image on the screen and the power LED blinks every 0.5 to 1 second.	The product is operating in power-saving mode. Press any key on the keyboard or move the mouse to return to normal operating mode.

Audio issues

Troubleshooting	Solutions
There is no sound.	Adjust the product volume. Check that the source device connected to the product is powered on.
The volume is too low.	Adjust the volume. If the volume is still low after turning it up to the maximum level, adjust the volume on your PC sound card or software program.

Source device issue

Troubleshooting	Solutions
A beeping sound is heard continuously when my PC is booting.	Have your PC serviced if it makes a beeping sound when booting.

Other issues

Troubleshooting	Solutions
The stand generates heat. Why is that? Does this mean that the product is defective?	The upper part of the stand may become slightly hot at room temperature. This occurs as the heat inside the stand releases naturally. The intensity of heat you feel can vary depending on whether the room is sealed or depending on the surrounding temperature. This does not indicate a defect. You can use the product without worry. It is recommended to use the product in a location that offers good ventilation at the back of the monitor stand.

Q & A

Question	Answer
How can I change the frequency?	<p>Set the frequency on your graphics card.</p> <ul style="list-style-type: none"> • Windows XP: Go to Control Panel → Appearance and Themes → Display → Settings → Advanced → Monitor, and adjust Refresh rate under Monitor settings. • Windows ME/2000: Go to Control Panel → Display → Settings → Advanced → Monitor, and adjust Refresh rate under Monitor settings. • Windows Vista: Go to Control Panel → Appearance and Personalization → Personalization → Display Settings → Advanced Settings → Monitor, and adjust Refresh rate under Monitor settings. • Windows 7: Go to Control Panel → Appearance and Personalization → Display → Screen Resolution → Advanced settings → Monitor, and adjust Refresh rate under Monitor settings.
How can I change the resolution?	<ul style="list-style-type: none"> • Windows XP: Go to Control Panel → Appearance and Themes → Display → Settings, and adjust the resolution. • Windows ME/2000: Go to Control Panel → Display → Settings, and adjust the resolution. • Windows Vista: Go to Control Panel → Appearance and Personalization → Personalize → Display Settings, and adjust the resolution. • Windows 7: Go to Control Panel → Appearance and Personalization → Display → Adjust Resolution, and adjust the resolution.

Question	Answer
How do I set power-saving mode?	<ul style="list-style-type: none"> • Windows XP: Set power-saving mode in Control Panel → Appearance and Themes → Display → Screen Saver Settings or BIOS SETUP on the PC. • Windows ME/2000: Set power-saving mode in Control Panel → Display → Screen Saver Settings or BIOS SETUP on the PC. • Windows Vista: Set power-saving mode in Control Panel → Appearance and Personalization → Personalize → Screen Saver Settings or BIOS SETUP on the PC. • Windows 7: Set power-saving mode in Control Panel → Appearance and Personalization → Personalize → Screen Saver Settings or BIOS SETUP on the PC.

NOTE

Refer to the user manual for your PC or graphics card for further instructions on adjustment.

Specifications

General

Model Name		S27B970D
Panel	Size	27 inches (69 cm)
	Display area	596.74 mm (H) x 335.66 mm (V) 23.49 inches (H) x 13.21 inches (V)
Synchronization	Horizontal Frequency	30 ~ 81 kHz
	Vertical Frequency	24 ~ 60 Hz (24 Hz / 30 Hz - MHL)
Display Color		16.7 M
Resolution	Optimum Resolution	2560 x 1440
	Maximum Resolution	2560 x 1440
Maximum Pixel Clock		241.5 MHz(DL-DVI)
Power Supply		This product uses 100 to 240 V. Refer to the label at the back of the product as the standard voltage can vary in different countries.
Ports	Side View	USB (1UP/2DN(USB2.0))
	Rear View	DVI(Dual link), HDMI(MHL), DisplayPort
Internal Speaker		7.0W X 2 (Channel)

Dimensions (W x H x D) / Weight		645.0 x 467.0 x 247.0 mm / 7.9 kg 25.4 x 18.4 x 9.7 inches / 17.4 lbs
Environmental conditions	Operating	Temperature: 50 °F ~ 104 °F (10 °C ~ 40 °C) Humidity: 10 % ~ 80 %, non-condensing
	Storage	Temperature: -4 °F ~ 113 °F (-20 °C ~ 45 °C) Humidity: 5 % ~ 95 %, non-condensing
Panel Dots (Pixels)		Due to the nature of the manufacturing of this product, approximately 1 pixel per million (1ppm) may be brighter or darker on the LCD panel. This does not affect product performance.

- ❖ The above specifications are subject to change without notice to improve quality.
- ❖ This device is a Class B digital apparatus.

(USA Only)

Dispose unwanted electronics through an approved recycler.
To find the nearest recycling location, go to our website:
www.samsung.com/recyclingdirect or call, (877) 278 - 0799

PowerSaver

The power-saving function of this product reduces power consumption by switching off the screen and changing the color of the power LED if the product is not used for a specified period of time. The power is not turned off in power-saving mode. To switch the screen back on, press any key on the keyboard or move the mouse. Power-saving mode functions only when the product is connected to a PC that has a power-saving function.

PowerSaver	Normal operation mode	Power saving mode	Power turned off (Power button)
Power lamp	On	Blinking	Off
Power Consumption	53 W (W/O USB)	less than 0.5 W	less than 0.5 W
	63 W (W/USB)	less than 0.5 W	less than 0.5 W

- ❖ The power consumption level can vary in different operating conditions or when settings are changed.
- ❖ To reduce the power consumption to 0 watts, turn off the power switch on the back of the product or disconnect the power cable. Be sure to disconnect the power cable when you will not be using the product for an extended period of time. To reduce the power consumption to 0 watts when the power switch is not available, disconnect the power cable.

Preset Timing Modes

- ❖ This product can be set to only one resolution for each screen size to obtain the optimum picture quality due to the nature of the panel. Therefore, a resolution other than the specified resolution may degrade the picture quality. To avoid this, it is recommended that you select the optimum resolution specified for the screen size of your product.

If a signal that belongs to the following standard signal modes is transmitted from your PC, the screen will automatically be adjusted. If the signal transmitted from the PC does not belong to the standard signal modes, the screen may be blank even though the power LED turns on. In such a case, change the settings according to the following table by referring to the graphics card user manual.

Resolution	Horizontal Frequency (kHz)	Vertical Frequency (Hz)	Clock frequency (MHz)	Sync Polarity (H/V)
IBM, 640 x 350	31.469	70.086	25.175	+/-
VESA, 640 x 480	31.469	59.940	25.175	-/-
MAC, 640 x 480	35.000	66.667	30.240	-/-
VESA, 640 x 480	37.861	72.809	31.500	-/-
VESA, 640 x 480	37.500	75.000	31.500	-/-
IBM, 720 x 400	31.469	70.087	28.322	-/+
VESA, 800 x 600	35.156	56.250	36.000	+/+
VESA, 800 x 600	37.879	60.317	40.000	+/+
VESA, 800 x 600	48.077	72.188	50.000	+/+
VESA, 800 x 600	46.875	75.000	49.500	+/+
MAC, 832 x 624	49.726	74.551	57.284	-/-
VESA, 1024 x 768	48.363	60.004	65.000	-/-
VESA, 1024 x 768	56.476	70.069	75.000	-/-
VESA, 1024 x 768	60.023	75.029	78.750	+/+
VESA, 1152 x 864	67.500	75.000	108.000	+/+

Resolution	Horizontal Frequency (kHz)	Vertical Frequency (Hz)	Clock frequency (MHz)	Sync Polarity (H/V)
MAC, 1152 x 870	68.681	75.062	100.000	-/-
VESA, 1280 x 800	49.702	59.810	83.500	-/+
VESA, 1280 x 960	60.000	60.000	108.000	+/+
VESA, 1280 x 1024	63.981	60.020	108.000	+/+
VESA, 1280 x 1024	79.976	75.025	135.000	+/+
VESA, 1440 x 900	55.935	59.887	106.500	-/+
VESA, 1600 x 1200	75.000	60.000	106.500	+/+
VESA, 1680 x 1050	65.290	59.954	146.250	-/+
VESA, 1920 x 1200	74.556	59.885	193.250	-/+
VESA, 2560 x 1440(RB)	88.787	59.951	241.500	+/-

✚ Horizontal Frequency

The time required to scan a single line from the left to the right side of the screen is called a horizontal cycle. The reciprocal number of a horizontal cycle is called horizontal frequency. Horizontal frequency is measured in kHz.

✚ Vertical Frequency

Repeating the same picture dozens of times per second allows you to view natural pictures. The repeat frequency is called "vertical frequency" or "refresh rate" and is indicated in Hz.

Appendix

Contact SAMSUNG WORLDWIDE

NOTE

If you have any questions or comments relating to Samsung products, please contact the SAMSUNG customer care Center.

NORTH AMERICA		
U.S.A	1-800-SAMSUNG (726-7864)	http://www.samsung.com
CANADA	1-800-SAMSUNG (726-7864)	http://www.samsung.com/ca http://www.samsung.com/ca_fr (French)
MEXICO	01-800-SAMSUNG (726-7864)	http://www.samsung.com
LATIN AMERICA		
ARGENTINA	0800-333-3733	http://www.samsung.com
BRAZIL	0800-124-421 4004-0000	http://www.samsung.com
BOLIVIA	800-10-7260	http://www.samsung.com
CHILE	800-SAMSUNG (726-7864) From mobile 02-482 82 00	http://www.samsung.com

COLOMBIA	01-8000112112	http://www.samsung.com
COSTA RICA	0-800-507-7267	http://www.samsung.com
DOMINICA	1-800-751-2676	http://www.samsung.com
ECUADOR	1-800-10-7267	http://www.samsung.com
EL SALVADOR	800-6225	http://www.samsung.com
GUATEMALA	1-800-299-0013	http://www.samsung.com
HONDURAS	800-27919267	http://www.samsung.com
JAMAICA	1-800-234-7267	http://www.samsung.com
NICARAGUA	00-1800-5077267	http://www.samsung.com
PANAMA	800-7267	http://www.samsung.com
PERU	0-800-777-08	http://www.samsung.com
PUERTO RICO	1-800-682-3180	http://www.samsung.com
TRINIDAD & TO-BAGO	1-800-SAMSUNG (726-7864)	http://www.samsung.com
VENEZUELA	0-800-100-5303	http://www.samsung.com

EUROPE		
ALBANIA	42 27 5755	http://www.samsung.co
AUSTRIA	0810 - SAMSUNG (7267864,€ 0.07/min)	http://www.samsung.com
BELGIUM	02-201-24-18	http://www.samsung.com/be(Dutch) http://www.samsung.com/be_fr(French)
BOSNIA	05 133 1999	http://www.samsung.com
BULGARIA	07001 33 11	http://www.samsung.com
CROATIA	062 SAMSUNG (062 726 7864)	http://www.samsung.com
CZECH	800-SAMSUNG(800-726786) Samsung Electronics Czech and Slovak, s.r.o., Oasis Florenc, Sokolovská 394/17, 180 00, Praha 8	http://www.samsung.com
DENMARK	70 70 19 70	http://www.samsung.com
FINLAND	030 - 6227 515	http://www.samsung.com
FRANCE	01 48 63 00 00	http://www.samsung.com
GERMANY	01805 - SAMSUNG (726-7864, € 0,14/Min)	http://www.samsung.com
CYPRUS	From landline : 8009 4000	http://www.samsung.com
GREECE	From landline : 80111-SAMSUNG (7267864) From landline & mobile : (+30) 210 6897691	http://www.samsung.com
HUNGARY	06-80-SAMSUNG (726-7864)	http://www.samsung.com
ITALIA	800-SAMSUNG (726-7864)	http://www.samsung.com
KOSOVO	+381 0113216899	http://www.samsung.com
LUXEMBURG	261 03 710	http://www.samsung.com

MACEDONIA	023 207 777	http://www.samsung.com
MONTENEGRO	020 405 888	http://www.samsung.com
NETHERLANDS	0900-SAMSUNG (0900-7267864) (€ 0,10/Min)	http://www.samsung.com
NORWAY	815-56 480	http://www.samsung.com
POLAND	0 801-1SAMSUNG(172-678) +48 22 607-93-33	http://www.samsung.com
PORTUGAL	808 20-SAMSUNG (808 20 7267)	http://www.samsung.com
RUMANIA	From landline : 08010-SAMSUNG (7267864) From landline & mobile : (+40) 21 206 01 10	http://www.samsung.com
SERBIA	0700 SAMSUNG (0700 726 7864)	http://www.samsung.com
SLOVAKIA	0800 - SAMSUNG (0800-726786)	http://www.samsung.com
SPAIN	902 - 1 - SAMSUNG (902 172 678)	http://www.samsung.com
SWEDEN	0771 726 7864 (SAMSUNG)	http://www.samsung.com
SWITZERLAND	0848 - SAMSUNG (7267864,CHF 0.08/min)	http://www.samsung.com http://www.samsung.com/ch_fr/ (French)
U.K	0330 SAMSUNG (7267864)	http://www.samsung.com
EIRE	0818 717100	http://www.samsung.com
LITHUANIA	8-800-77777	http://www.samsung.com
LATVIA	8000-7267	http://www.samsung.com
ESTONIA	800-7267	http://www.samsung.com
TURKEY	444 77 11	http://www.samsung.com

CIS		
RUSSIA	8-800-555-55-55	http://www.samsung.com
GEORGIA	8-800-555-555	http://www.samsung.com
ARMENIA	0-800-05-555	http://www.samsung.com
AZERBAIJAN	088-55-55-555	http://www.samsung.com
KAZAKHSTAN	8-10-800-500-55-500 (GSM:7799)	http://www.samsung.com
UZBEKISTAN	8-10-800-500-55-500	http://www.samsung.com
KYRGYZSTAN	00-800-500-55-500	http://www.samsung.com
TADJIKISTAN	8-10-800-500-55-500	http://www.samsung.com
MONGOLIA	-	http://www.samsung.com
UKRAINE	0-800-502-000	http://www.samsung.com/ua http://www.samsung.com/ua_ru
BELARUS	810-800-500-55-500	http://www.samsung.com
MOLDOVA	00-800-500-55-500	http://www.samsung.com

ASIA PACIFIC		
AUSTRALIA	1300 362 603	http://www.samsung.com
NEW ZEALAND	0800 SAMSUNG (0800 726 786)	http://www.samsung.com
CHINA	400-810-5858	http://www.samsung.com
HONG KONG	(852) 3698 - 4698	http://www.samsung.com/hk http://www.samsung.com/hk_en/
INDIA	1800 1100 11 3030 8282 1800 3000 8282 1800 266 8282	http://www.samsung.com
INDONESIA	0800-112-8888 021-5699-7777	http://www.samsung.com
JAPAN	0120-327-527	http://www.samsung.com
MALAYSIA	1800-88-9999	http://www.samsung.com
PHILIPPINES	1-800-10-SAMSUNG (726-7864) for PLDT 1-800-3-SAMSUNG (726-7864) for Digitel 1-800-8-SAMSUNG (726-7864) for Globe 02-5805777	http://www.samsung.com
SINGAPORE	1800-SAMSUNG (726-7864)	http://www.samsung.com
THAILAND	1800-29-3232 02-689-3232	http://www.samsung.com
TAIWAN	0800-329-999 0266-026-066	http://www.samsung.com
VIETNAM	1 800 588 889	http://www.samsung.com

MIDDLE EAST		
IRAN	021-8255	http://www.samsung.com
OMAN	800-SAMSUNG (726-7864)	http://www.samsung.com
KUWAIT	183-2255	http://www.samsung.com
BAHRAIN	8000-4726	http://www.samsung.com
EGYPT	08000-726786	http://www.samsung.com
JORDAN	800-22273	http://www.samsung.com
MOROCCO	080 100 2255	http://www.samsung.com
SAUDI ARABIA	9200-21230	http://www.samsung.com
U.A.E	800-SAMSUNG (726-7864)	http://www.samsung.com

AFRICA		
CAMEROON	7095- 0077	http://www.samsung.com
COTE D'IVOIRE	8000 0077	http://www.samsung.com
GHANA	0800-10077 0302-200077	http://www.samsung.com
KENYA	0800 724 000	http://www.samsung.com
NIGERIA	0800-726-7864	http://www.samsung.com
SENEGAL	800-00-0077	http://www.samsung.com
SOUTH AFRICA	0860-SAMSUNG (726-7864)	http://www.samsung.com
TANZANIA	0685 88 99 00	http://www.samsung.com
UGANDA	0800 300 300	http://www.samsung.com

Responsibility for the Pay Service (Cost to Customers)

NOTE

When the service is requested, in spite of in warranty, we may charge you for a visit from a service technician in the following cases.

Not a product defect

Cleaning of the product, Adjustment, Explanation, Re-installation and etc.

- If a service technician gives instructions on how to use product or simply adjusts options without disassembling product.
- If a defect is caused by external environmental factors (Internet, Antenna, Wired Signal, etc.).
- If a product is reinstalled or devices are connected additionally after installing the purchased product for the first time.
- If a product is reinstalled to move to a different spot or to move to a different house.
- If customer requests instructions on how to use because of another company's product.
- If customer requests instructions on how to use the network or another company's program.
- If customer requests software installation and setup for the product.
- If a service technician removes/cleans dusts or foreign materials inside of the product.
- If customer requests an installation additionally after purchasing a product through home-shopping or online.

A Product damage caused by customer's fault

Product damage caused by customer's mishandling or wrong repair

If a product damage is caused by;

- external impact or drop.
- use of supplies or separately sold product unspecified by Samsung.
- repair from a person besides an engineer of outsourcing service company or partner of Samsung Electronics Co., Ltd..
- remodeling or repairing the product by customer.
- using it with incorrect voltage or non-authorized electrical connections.
- not following the "cautions" in User Manual.

Others

- If product fails by natural disaster (lightning, fire, earthquake, flood damage, etc)
- If consumable components are all used up (Battery, Toner, Fluorescent lights, Head, Vibrator, Lamp, Filter, Ribbon, etc.)

NOTE

If customer requests a service in case the product has no defect, service fee may be charged. So please read User Manual first.

Correct Disposal

Correct Disposal of This Product



(Applicable in the European Union and other European countries with separate collection systems)

This marking on the product, accessories or literature indicates that the product and its electronic accessories (e.g. charger, headset, USB cable) should not be disposed of with other household waste at the end of their working life. To prevent possible harm to the environment or human health from uncontrolled waste disposal, please separate these items from other types of waste and recycle them responsibly to promote the sustainable reuse of material resources.

Household users should contact either the retailer where they purchased this product, or their local government office, for details of where and how they can take these items for environmentally safe recycling.

Business users should contact their supplier and check the terms and conditions of the purchase contract. This product and its electronic accessories should not be mixed with other commercial wastes for disposal.

Correct disposal of batteries in this product



(Applicable in the European Union and other European countries with separate battery return systems.)

The marking on the battery, manual or packaging indicates that the battery in this product should not be disposed of with other household waste. Where marked, the chemical symbols Hg, Cd or Pb indicate that the battery contains mercury, cadmium or lead above the reference levels in EC Directive 2006/66.

The battery incorporated in this product is not user replaceable. For information on its replacement, please contact your service provider. Do not attempt to remove the battery or dispose it in a fire. Do not disassemble, crush, or puncture the battery. If you intend to discard the product, the waste collection site will take the appropriate measures for the recycling and treatment of the product, including the battery.

Terminology

OSD(On Screen Display)

On screen display (OSD) allows you to customize on-screen settings to optimize the picture quality as required. You can change the screen brightness, tint, size and many other settings using menus displayed on the screen.

Gamma

The Gamma menu adjusts the grey scale that represents middle tones on the screen. Adjusting the brightness brightens the whole screen, but adjusting Gamma only brightens the medium brightness.

Grey scale

Scale refers to levels of color intensity that show variations of color change from darker areas to brighter areas on the screen. Changes to the screen brightness are expressed with black and white variation, and grey scale refers to the medium area between black and white. Changing the grey scale through Gamma adjustment will change the medium brightness on the screen.

Scanning rate

Scanning rate, or refresh rate, refers to the frequency of screen refreshes. Screen data is transmitted as it refreshes to display an image, although the refreshing is invisible to the naked eye. The number of screen refreshes is called scanning rate and is measured in Hz. A scanning rate of 60Hz means that the screen refreshes 60 times per second. The screen scanning rate depends on the performance of the graphics cards in your PC and monitor.

Horizontal Frequency

Characters or images displayed on the monitor screen consist of numerous dots (pixels). Pixels are transmitted in horizontal lines, which are then arranged vertically to create an image. The horizontal frequency is measured in kHz and represents how many times horizontal lines per second are transmitted and displayed on the monitor screen. A horizontal

frequency of 85 means that the horizontal lines that make up an image are transmitted 85000 times per second. The horizontal frequency is indicated in 85kHz.

Vertical Frequency

One image is made of numerous horizontal lines. The vertical frequency is measured in Hz and represents how many images can be created per second by those horizontal lines. A vertical frequency of 60 means that an image is transmitted 60 times per second. The vertical frequency is also called "refresh rate" and affects screen flicker.

Resolution

Resolution is the number of horizontal pixels and vertical pixels that form a screen. It represents the level of display detail. A higher resolution displays a greater amount of information on the screen and is suitable for performing multiple tasks at the same time. E.g. A resolution of 1920 x 1080 consists of 1920 horizontal pixels (horizontal resolution) and 1080 vertical lines (vertical resolution).

Plug & Play

The Plug & Play feature allows the automatic exchange of information between a monitor and PC to produce an optimum display environment. The monitor uses VESA DDC (international standard) to execute Plug & Play.

MHL (Mobile High-Definition Link)

The MHL feature allows you to view videos and photos (saved on a connected mobile device that supports MHL) using the product screen.

Index

Index

A

Auto Source 49

B

Blue 42
Brightness 37

C

Checking the Contents 13
Cleaning 7
Color Mode 40
Color Temp. 42
Compatible Types of Calibrators 19
Completing Calibration 27
Components 14
Configuring Brightness and Contrast in the Initial Screen 53
Configuring Color Mode 40
Configuring Color Mode in the Initial Screen 52
Configuring Volume in the Initial Screen 53
Connecting and Using a PC 31
Connecting the Calibrator 21
Connecting the Product to a PC as a USB HUB 33
Connecting to a Video Device 36
Contact
SAMSUNG WORLDWIDE 60
Contrast 38
Copyright 5
Correct Disposal 64

Correct posture to use the product 12
Customer Registration 60

D

Display Time 49
Dynamic Contrast 37

E

Eco Saving 47

F

Features of the NCE Program 21

G

Gamma 43
General 57
Green 41

H

HDMI Black Level 39
H-Position 45

I

Image Size 44
INFORMATION 52
Items sold separately 14

K

Key Repeat Time 50

L

Language 48
Layout and Menu Items on the Calibration Screen 24
Layout and Menu Items on the Edit Screen 23
Layout and Menu Items on the NCE Home Screen 21
Layout and Menu Items on the New Profile Screen 24
Layout and Menu Items on the Uniformity Screen 23

M

Menu H-Position 46
Menu Transparency 47
Menu V-Position 46
MHL 28

N

NCE Program	
Installation/Uninstallation	20

O

Off Timer On/Off	50
Off Timer Setting	51

P

Parts	15
PC/AV Mode	48
Power Consumption	58
PowerSaver	58
Preparing for Calibration	27
Profile List	22

Q

Q & A	56
-------	----

R

Red	41
Requirements Before	
Contacting Samsung	
Customer Service Center	54
Reset	51
Response Time	39
Responsibility for the	
Pay Service	
(Cost to Customers)	63

S

Safety Precautions	6
Sharpness	38
Starting NCE	
(Natural Color Expert)	21

T

Terminology	65
-------------	----

U

Using MHL	28
-----------	----

V

V-Position	45
------------	----

W

What is Monitor Calibration?	19
What is NCE	
(Natural Color Expert)?	20