

# MIC Series 440 Explosion-Protected Camera

www.boschsecurity.com



**BOSCH**  
Invented for life



- ▶ Certified to ATEX Directive 94/9/EC Exd IIC T6 and IECEx SIR 11.0023X
- ▶ CSA, ATEX, IECEx, and CNEX certified
- ▶ Industry-leading IP68 rated housing
- ▶ Integrated wiper

The MIC Series 440 explosion-protected camera has been designed to offer an extremely reliable, robust, and high quality surveillance solution for potentially volatile security applications that demand the very best performance. Precision engineered to exacting standards, the range meets the requirements of ATEX Directive 94/9/EC Exd IIC T6 and CSA Class I, Division 1, Groups CD, Class II, Division 1, Groups EFG, T6 for safe use in explosive atmospheres such as those found in oil, gas, chemical processing sites, and petrochemical refineries.

Rated to an industry leading IP68, the specially designed camera housing is machined from solid aluminum. The MIC Series 440 camera ensures corrosion protection by using two different processes; first an Alocrom 1200 coating, then a robust polyester powder paint coating. Alocrom 1200 is a chromate conversion coating of aluminum, used in the aerospace and defense industries where a protective layer is required to improve corrosion resistance. Sealed with 'O'-rings, the MIC Series 440 camera is suitable for installation in the harshest of environments. The optically-perfect flat viewing window and integrated wiper ensure razor sharp images are captured in even

the most demanding conditions. This allows the MIC Series 440 explosion-protected range to function perfectly in highly hazardous areas, such as offshore oil rigs.

The use of high-specification motors ensures reliable operation, while ground-breaking resolver technology provides pin-point accuracy and affords the user full 360° continuous rotation pan and 240° tilt control. A choice of true day/night camera modules, offering up to 36x optical zoom (12x digital), coupled with flexible upright or inverted mounting capability, allows the perfect field of view to be achieved every time.

## Functions

### ATEX and CSA Certified

Meets the requirements of ATEX Directive 94/9/EC Exd IIC T6 and CSA Class I, Division 1, Groups CD, Class II, Division 1, Groups EFG, T6 for safe use in explosive atmospheres.

**Rated to an industry leading IP68**

Zero dust ingress and ability to withstand sustained periods of immersion under water, the MIC Series 440 explosion-protected range is perfectly suited for installation, in even the most unforgiving environments.

**Integrated wiper**

Regardless of the weather, the MIC Series 440 explosion-protected camera is able to capture the highest possible quality image year round, thanks to its integrated wiper.

**Certifications and approvals**

**Approvals**

ATEX certified	Directive 94/9/EC Ex d IIC T6
CSA C/US	Class I, Division 1, Groups CD Class II, Division 1, Groups EFG Temperature Code T6
IECEX SIR	11.0023X
CCC	CNEEx 11.3484X
Electromagnetic Compatibility (EMC)	Complies with FCC part 15, ICES-003, and CE regulations, including EN50130-4, EN61000-3-2:2006, EN61000-3-3:1995, and EN55022:2006 inc AL:2007
Safety	Complies with CE regulations, UL, EN, and IEC standards 60950-1 & 22
Weatherproofing	IP68 (1m submersion for 24 hrs)

Region	Certification	
Europe	CE	Declaration of Conformity
	CE	Sira Examination, Issue 11
Canada	CSA	Certificate of Compliance

**Installation/configuration notes**

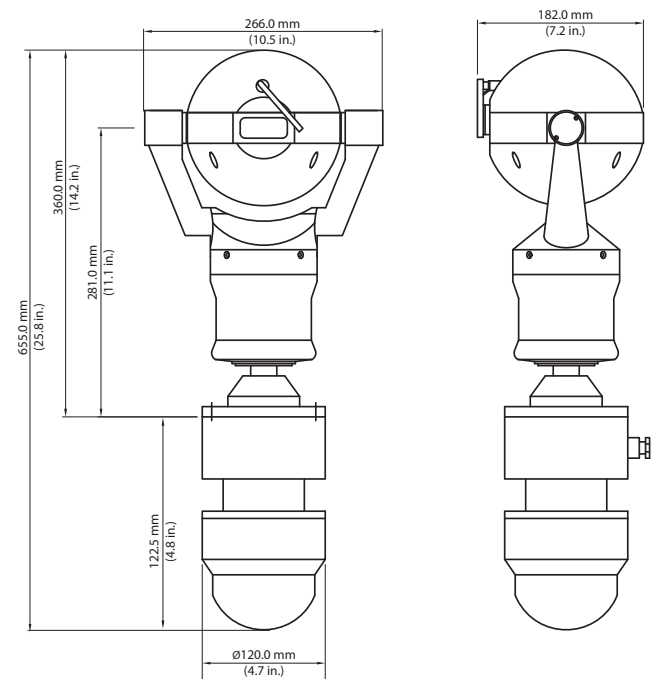

**Parts included**

Quantity	Part
1	MIC440 with Exd DCA attached
1	Quick Installation Guide
1	MIC Series 440 Installation Manual
1	USB to RS-485 converter kit
4	M3 x 25 mm stainless screws
1	Nebar gasket

**Technical specifications**

**Camera Module**

Image sensor	1/4-inch EXview CCD
Picture elements	PAL: Approximately 440,000; 752(H) x 582(V) NTSC: Approximately 380,000; 768 (H) x 494 (V)
Horizontal resolution	470 TVL NTSC/PAL typical
Filter	Automatic mechanical IR cut filter
Focus system	Auto or manual
Iris	Auto or manual with slow shutter integration modes
Synchronization	Internal / External (V-Lock)
Recommended illumination	100 to 100,000 lx

Signal-to-Noise ratio (SNR)	50 dB or more
Back Light Compensation (BLC)	On/Off
White balance	Automatic
Automatic Gain Control (AGC)	-3 to -28 dB, 2 dB steps
Aperture control	16 Steps

Lens	F=3.4 mm (WIDE) to 122.4 mm (TELE), F1.6 to F4.5
Zoom	36x optical (12x digital)
Angle of view	57.8° (WIDE end) to 1.7° (TELE end)
Minimum illumination	1.4 lux (1/60 s NTSC, 1/50 s PAL, typical, 50 IRE) 0.1 lux (1/4 s NTSC, 1/3 s PAL, typical, 50 IRE) ICR-ON mode: 0.01 lux (1/4 s NTSC, 1/3 s PAL)
Shutter speed	1/4 to 1/10,000s (20 steps) NTSC, 1/3 to 1/10,000s (20 steps) PAL

### Operational

Auto flip	Yes
Manual flip	Yes
Presets	64 telemetry presets utilizing resolver technology
Preset tours	6 tours each with up to 32 presets
Sector titles	Yes (64 sectors) 20 characters per title
Preset titles	20 character caption for each of the 64 presets
Home position	Yes (preset 1 or tour)

### Communication and Protocols

Communication	RS485 / RS422
Control protocol	Bosch and Pelco protocol variants available. Bi-phase control requires Biphase to RS485 converter (MIC-BP4) to be installed in the power supply (available separately).

### Connectivity

Video	Co-axial via composite cable
Telemetry	Twisted pair. Simplex, half and full duplex operation via composite cable
Power	Via composite cable

### Alarms

Alarm inputs	1 tamper input (additional inputs possible with optional alarm card in PSU)
Alarm communication	Tamper switch (ground connection)

### Mechanical

Drive unit	Integral pan/tilt motor drive
Pan angle	360° continuous rotation
Pan speed	Up to 90° per second (variable)
Tilt angle	240°
Tilt speed	0.2° to 90° per second (variable)
Speed control	Closed-loop electronics
Preset accuracy	Better than 0.08°
Proportional Pan/Tilt to zoom	Yes

### Electrical

Input voltage	18VAC
Power consumption	25.2 W max

### Environmental

Operating temperature	-20 °C to +60 °C (-4 °F to 140 °F)
Weatherproofing	IP68 (1m submersion for 24 hours maximum)

### Physical

Dimensions (W x H x D)	286 x 523.6 x 189 mm (11.26 x 20.61 x 7.44 in.) (including deep conduit adapter)
Weight	15.5 Kg (34.17 lb) (including 4-in. (101.6 mm) pitch circle diameter (PCD) base and supplied deep conduit adapter)
Viewing window	Tempered flat glass
Construction material	Machined aluminum
Standard colors	Black (RAL 9005)
Standard finish	Alocrom 1200 surface treatment with powder coat paint.
Window wiper	Standard

**Note 1:** MIC Series power supplies and accessories are not ATEX compliant. These should be located outside the hazardous area or provided with ATEX-compliant enclosures and cable conduit or cable glands.

**Note 2:** Not all models are available in all regions. For more information, contact your local Bosch representative.

### Ordering information

#### **MIC440AXBUD14636N MIC EXP PF, 36x NTSC, Black, Pel Prtcl**

MIC 36x Optical zoom, Explosion-Protected, black, upright, Pelco Protocol, wiper fitted, NTSC  
Order number **MIC440AXBUD14636N**

#### **MIC440AXBUD14636P MIC EXP PF, 36x PAL, Black, Pel Prtcl**

MIC 36x Optical zoom, Explosion-Protected, black, upright, Pelco Protocol, wiper fitted, PAL  
Order number **MIC440AXBUD14636P**

#### **MIC440AXBUP14636N MIC EXP PF, 36x NTSC, Black, Bosch Prtcl**

MIC 36x Optical zoom, Explosion-Protected, black, upright, Bosch Protocol, wiper fitted, NTSC  
Order number **MIC440AXBUP14636N**

#### **MIC440AXBUP14636P MIC EXP PF, 36x PAL, Black, Bosch Prtcl**

MIC 36x Optical zoom, Explosion-Protected, black, upright, Bosch Protocol, wiper fitted, PAL  
Order number **MIC440AXBUP14636P**

#### **Accessories**

#### **MIC-24PSU-2 MIC Power Supply Unit, 24VAC, 50/60 Hz**

24 VAC, 50/60 Hz power supply with two video outputs for MIC Series cameras.  
Order number **MIC-24PSU-2**

#### **MIC-115PSU-2 MIC Power Supply Unit, 120VAC, 50/60 Hz**

115 VAC, 50/60 Hz power supply with two video outputs for MIC Series cameras.  
Order number **MIC-115PSU-2**

#### **MIC-240PSU-2 MIC Power Supply Unit, 230 VAC, 50/60 HZ**

230 VAC, 50/60 Hz power supply with two video outputs for MIC Series cameras.  
Order number **MIC-240PSU-2**

#### **MIC Cable 2M**

2 meter (6.56 ft) composite cable with plug for power, data and video for MIC Series cameras  
Order number **MIC-CABLE-2M**

#### **MIC Cable 10M**

10 meter (32.81 ft) composite cable with plug for power, data and video for MIC Series cameras  
Order number **MIC-CABLE-10M**

#### **MIC Cable 20M**

20 meter (62.62 ft) composite cable with plug for power, data and video for MIC Series cameras  
Order number **MIC-CABLE-20M**

#### **MIC Cable 25M**

25 meter (82.02 ft) composite cable with plug for power, data and video for MIC Series cameras  
Order number **MIC-CABLE-25M**

#### **MIC-SPR Spreader Plate**

Aluminum spreader plate suitable for brickwork surface mounting – black leatherette finish RAL9005  
Order number **MIC-SPR**

#### **MIC-CMB Corner Mount Bracket**

Corner mount bracket - black leatherette finish RAL9005  
Order number **MIC-CMB**

#### **MIC-PMB Pole Mount Bracket**

Pole mount bracket (includes 2 x 455 mm stainless steel banding straps for pole diameters 75 to 145 mm)  
Order number **MIC-PMB**

#### **MIC-WMB-B Wall Mount Bracket, Black**

Wall mount bracket, black leatherette finish (RAL9005)  
Order number **MIC-WMB-B**

#### **MIC-BP4 Biphase Converter**

Biphase converter for non-IR versions of MIC series power supply units  
Order number **MIC-BP4**

#### **MIC-ALM Alarm and Washer Pump Drive Card**

8 Input alarm and washer pump drive card for PSU (Not for IR PSU). Requires washer pump, purchase separately.  
Order number **MIC-ALM**

#### **MIC-WKT Washer Kit**

Washer kit for non-infrared MIC camera models (includes washer pump drive card, washer nozzle and mounting brackets for wall and 4 in. PCD base). Requires washer pump, purchase separately.  
Order number **MIC-WKT**

#### **MIC440 Sunshield**

Sunshield for the MIC440 camera.  
Order number **MIC440SUNSHIELD**

**Represented by:**

**North America:**

Bosch Security Systems, Inc.  
130 Perinton Parkway  
Fairport, New York, 14450, USA  
Phone: +1 800 289 0096  
Fax: +1 585 223 9180  
security.sales@us.bosch.com  
www.boschsecurity.us

**Europe, Middle East, Africa:**

Bosch Security Systems B.V.  
P.O. Box 80002  
5617 BA Eindhoven, The Netherlands  
Phone: + 31 40 2577 284  
Fax: +31 40 2577 330  
emea.securitysystems@bosch.com  
www.boschsecurity.com

**Asia-Pacific:**

Robert Bosch (SEA) Pte Ltd, Security  
Systems  
11 Bishan Street 21  
Singapore 573943  
Phone: +65 6571 2808  
Fax: +65 6571 2699  
apr.securitysystems@bosch.com  
www.boschsecurity.asia

**China:**

Bosch (Shanghai) Security Systems Ltd.  
203 Building, No. 333 Fuquan Road  
North IBP  
Changning District, Shanghai  
200335 China  
Phone +86 21 22181111  
Fax: +86 21 22182398  
www.boschsecurity.com.cn

**Latin America and Caribbean:**

Robert Bosch Ltda Security Systems Division  
Via Anhanguera, Km 98  
CEP 13065-900  
Campinas, Sao Paulo, Brazil  
Phone: +55 19 2103 2860  
Fax: +55 19 2103 2862  
latam.boschsecurity@bosch.com  
www.boschsecurity.com