

# THERMAL PRINTER TSP800II SERIES

## *Hardware Manual*

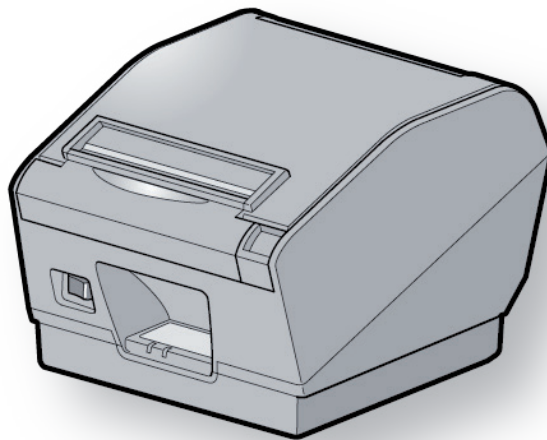

**star** 

**Federal Communications Commission  
Radio Frequency Interference  
Statement**

This device complies with Part 15 of FCC Rules and Industry Canada licence-exempt RSS standard(s). Operation is subject to the following two conditions:

- (1) This device may not cause harmful interference, and
- (2) this device must accept any interference received, including interference that may cause undesired operation.

Le présent appareil est conforme aux CNR d'Industrie Canada applicables aux appareils radio exempts de licence. L'exploitation est autorisée aux deux conditions suivantes :

- (1) l'appareil ne doit pas produire de brouillage, et
- (2) l'utilisateur de l'appareil doit accepter tout brouillage radioélectrique subi, même si le brouillage est susceptible d'en compromettre le fonctionnement.

***FCC CAUTION***

Changes or modifications not expressly approved by the party responsible for compliance could void the user's authority to operate the equipment.

For compliance with the Federal Noise Interference Standard, this equipment requires a shielded cable.

For RF interference suppression, if a ferrite core is provided with this device, affix it to the interface cable.

***NOTE:***

This equipment has been tested and found to comply with the limits for a Class A digital device, pursuant to Part 15 of the FCC Rules. These limits are designed to provide reasonable protection against harmful interference when the equipment is operated in a commercial environment. This equipment generates, uses and can radiate radio frequency energy and, if not installed and used in accordance with the instruction manual, may cause harmful interference to radio communications. Operation of this equipment in a residential area is likely to cause harmful interference in which case the user will be required to correct the interference at his own expense.

CAN ICES-3 (A) / NMB-3 (A)

This equipment complies with FCC/IC radiation exposure limits set forth for an uncontrolled environment and meets the FCC radio frequency (RF) Exposure Guidelines in Supplement C to OET65 and RSS-102 of the IC radio frequency (RF) Exposure rules. This equipment has very low levels of RF energy that it deemed to comply without maximum permissive exposure evaluation(MPE). But it is desirable that it should be installed and operated keeping the radiator at least 20cm or more away from person's body (excluding extremities: hands,wrists,feet and ankles).

Cet équipement est conforme aux limites d'exposition aux rayonnements énoncées pour un environnement non contrôlé et respecte les règles les radioélectriques (RF) de la FCC lignes directrices d'exposition dans le Supplément C à OET65 et d'exposition aux fréquences radioélectriques (RF) CNR-102 de l'IC. Cet équipement émet une énergie RF très faible qui est considérée conforme sans évaluation de l'exposition maximale autorisée. Cependant, cet équipement doit être installé et utilisé en gardant une distance de 20 cm ou plus entre le dispositif rayonnant et le corps (à l'exception des extrémités : mains, poignets, pieds et chevilles).

## Caution Symbol



These symbols are located near the thermal print head.

Because the thermal print head is hot immediately after printing, do not touch it. Static electricity can damage the thermal print head. To protect the thermal print head from static electricity, do not touch it.



This symbol is located near the cutter.

Never touch the cutter blade, as you could injure your fingers.



This symbol is located near the peripheral drive connector.

Do not connect this to a telephone.

## Trademark acknowledgments

**TSP800II:** Star Micronics Co., Ltd.

## Notice

- All rights reserved. Reproduction of any part of this manual in any form whatsoever, without STAR's express permission is forbidden.
- The contents of this manual are subject to change without notice.
- All efforts have been made to ensure the accuracy of the contents of this manual at the time of going to press. However, should any errors be detected, STAR would greatly appreciate being informed of them.
- The above notwithstanding, STAR can assume no responsibility for any errors in this manual.
- IOS is a trademark or registered trademark of Cisco in the U.S. and other countries and is used under license.
- Android is a trademark of Google Inc.
- Windows is registered trademarks of Microsoft Corporation.
- The Bluetooth® word mark and logos are registered trademarks owned by the Bluetooth SIG, Inc.

# TABLE OF CONTENTS

<b>1. Unpacking and Installation</b> .....	<b>1</b>
1-1. Unpacking .....	1
1-2. Notes about Installation .....	2
<b>2. Parts Identification and Nomenclature</b> .....	<b>3</b>
<b>3. Setup</b> .....	<b>4</b>
3-1. Connecting the Cable to the PC .....	4
3-2. Connecting the Cable to the Printer .....	5
3-3. Connecting the Optional AC Adapter .....	8
3-4. Turning Power On.....	9
3-5. Connecting to a Peripheral Unit.....	10
3-6. Loading the Paper Roll .....	11
3-7. Bluetooth Settings (For Bluetooth Interface Models only).....	14
3-8. Setup Precautions.....	19
<b>4. Consumable Parts</b> .....	<b>21</b>
4-1. Thermal Paper Roll .....	21
4-2. Thermal Label Paper Roll (Tack Label Paper) .....	23
<b>5. Control Panel and Other Functions</b> .....	<b>26</b>
5-1. Control Panel.....	26
5-2. Errors.....	26
<b>6. Adjusting the Sensor</b> .....	<b>28</b>
6-1. Adjusting the Near End Sensor Position.....	28
6-2. PE and BM ( Paper End and Black Mark ) Sensor Adjustment.....	30
6-3. NE (Near End) Sensor Adjustment .....	31
<b>7. Preventing and Clearing Paper Jams</b> .....	<b>32</b>
7-1. Preventing Paper Jams .....	32
7-2. Removing Paper Jam .....	32
<b>8. Periodical Cleaning</b> .....	<b>33</b>
8-1. Cleaning the Thermal Head .....	33
8-2. Cleaning the Rubber Roller .....	33
8-3. Cleaning the Sensors and the Surrounding Areas .....	33
8-4. Cleaning the Paper Holder and the Surrounding Area.....	33

Please access the following URL

<http://www.star-m.jp/eng/dl/dl02.htm>  
for the latest revision of the manual.

# 1. Unpacking and Installation

## 1-1. Unpacking

After unpacking the unit, check that all the necessary accessories are included in the package.

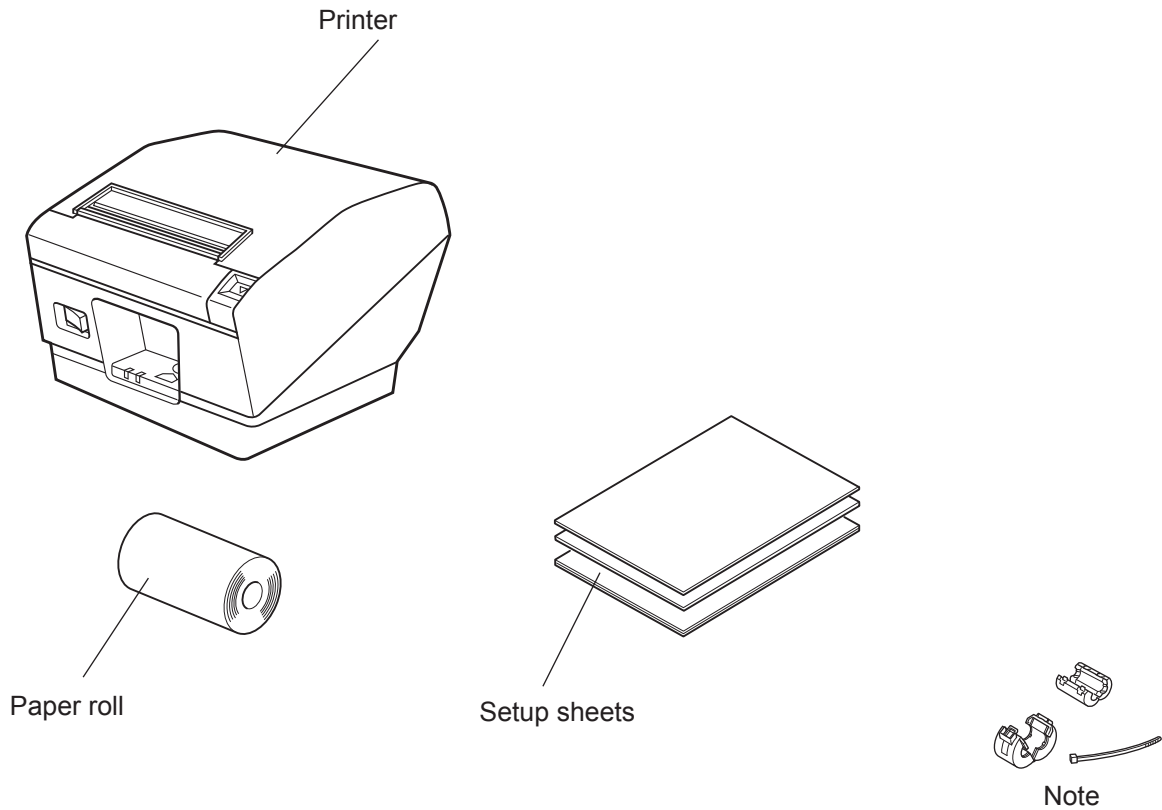

**Note:** The ferrite core and fastener provided with your printer depend on your printer configuration.

**Fig. 1-1 Unpacking**

If anything is missing, contact the dealer where you bought the printer and ask them to supply the missing part. Note that it is a good idea to keep the original box and all the packing materials just in case you need to pack the printer up again and send it somewhere at a later date.

## **1-2. Notes about Installation**

1. Choose a firm, level surface where the printer will not be exposed to vibration.
2. Make sure that the printer is connected to a reliable power outlet. It should not be on the same electric circuit as copiers, refrigerators, or other appliances that cause power spikes.
3. The power outlet you plan to connect to for power should be nearby and unobstructed.
4. Make sure that the printer is not exposed to direct sunlight.
5. Make sure that the printer is well away from heaters and other sources of extreme heat.
6. Do not locate the printer in a badly ventilated or dusty environment.
7. Make sure that the room where you are using the printer is not too humid.
8. Use the printer within the boundaries indicated in the environmental requirements. Even when the ambient temperature and humidity are within the specifications, avoid radical changes in environmental conditions. The suitable operating temperature range is as follows:  
Operating temperature: 5°C to 45°C
9. When disposing of the printer, obey local regulations.

## 2. Parts Identification and Nomenclature

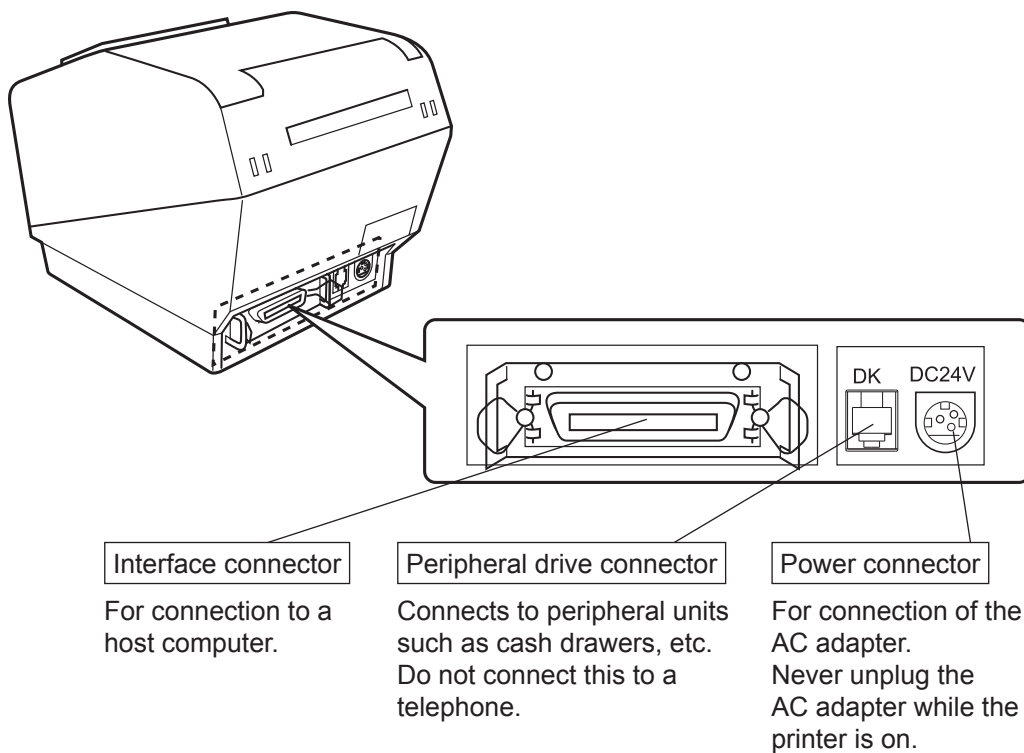
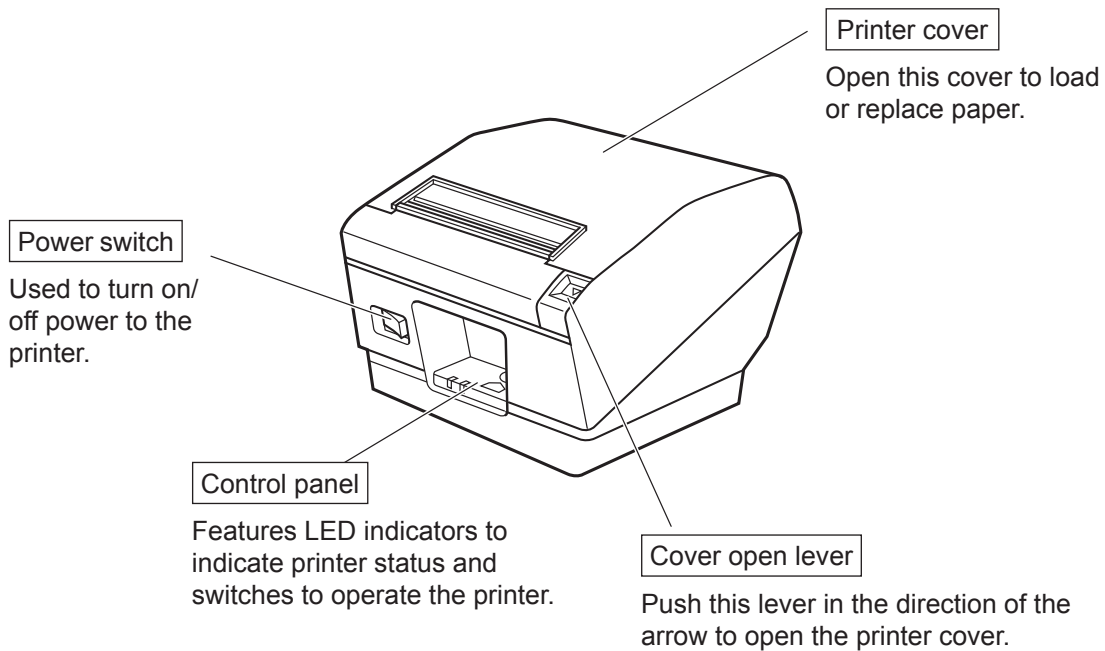

# 3. Setup

## 3-1. Connecting the Cable to the PC

### 3-1-1. Parallel Interface Cable

Connect the parallel interface cable to a parallel port of your PC.

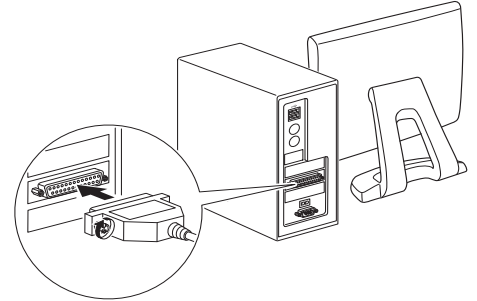

### 3-1-2. RS-232C Interface Cable

Connect the RS-232C interface cable to a RS-232C port of your PC.

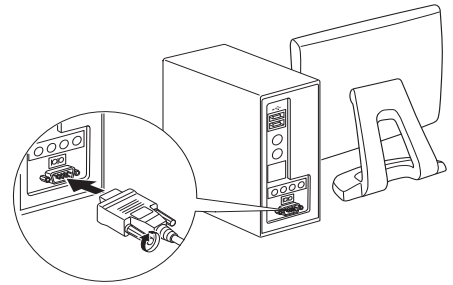

### 3-1-3. USB Interface Cable

Connect the USB interface cable to a USB port of your PC.

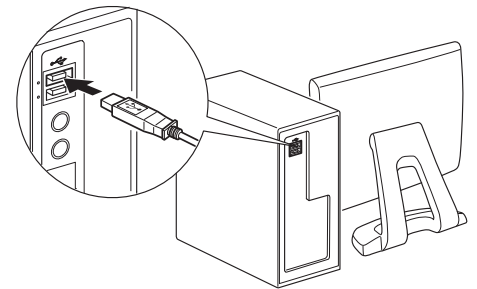

### 3-1-4. Ethernet Interface cable

Connect the ethernet interface cable to a ethernet port of your PC.

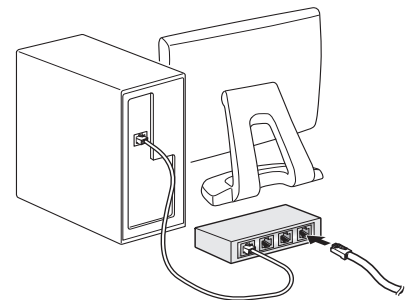



## 3-2. Connecting the Cable to the Printer

Note that the interface cable is not provided. Please use a cable that meets specifications.

### ⚠ CAUTION

*Before connecting/disconnecting the interface cable, make sure that power to the printer and all the devices connected to the printer is turned off. Also make sure the power cable plug is disconnected from the AC outlet.*

#### 3-2-1. Parallel Interface Cable

- (1) Make sure the printer is turn off.
- (2) Affix the ferrite core onto the cable as shown in the illustration.
- (3) Pass the fastener through the ferrite core.
- (4) Loop the fastener around the cable and lock it.  
Use scissors to cut off any excess.

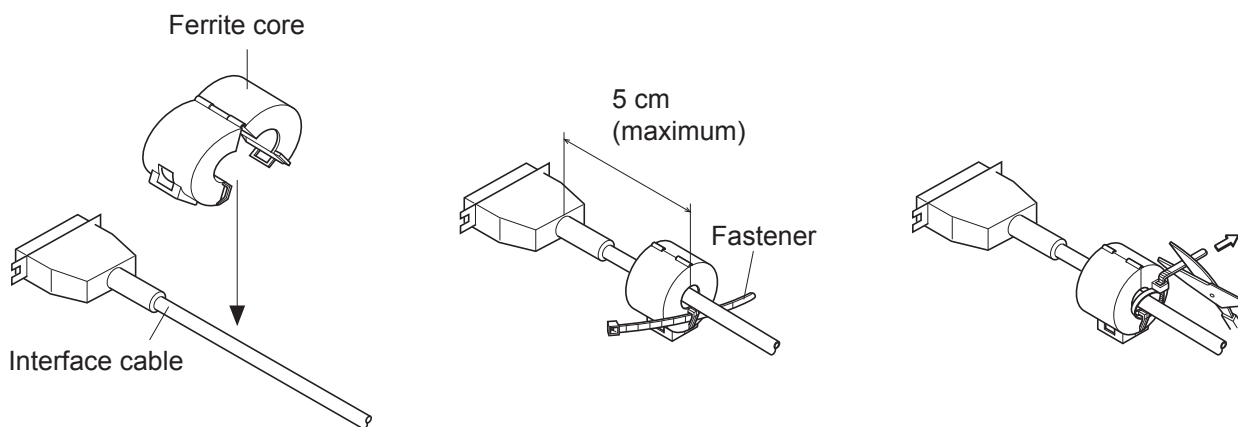
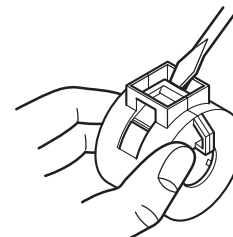

- (5) Connect the interface cable to the connector on the rear panel of the printer.
- (6) Fasten the connector clasps.

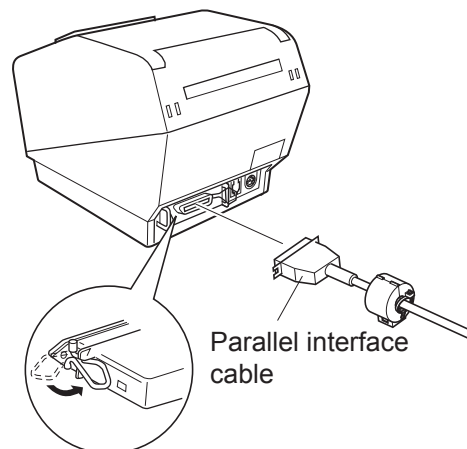

### 3-2-2. RS-232C Interface Cable

- (1) Make sure the printer is turn off.

---

#### **⚠ CAUTION**

*Before connecting/disconnecting the interface cable, make sure that power to the printer and all the devices connected to the printer is turned off. Also make sure the power cable plug is disconnected from the AC outlet.*

---

- (2) Connect the interface cable to the connector on the rear panel of the printer.
- (3) Tighten the connector screws.

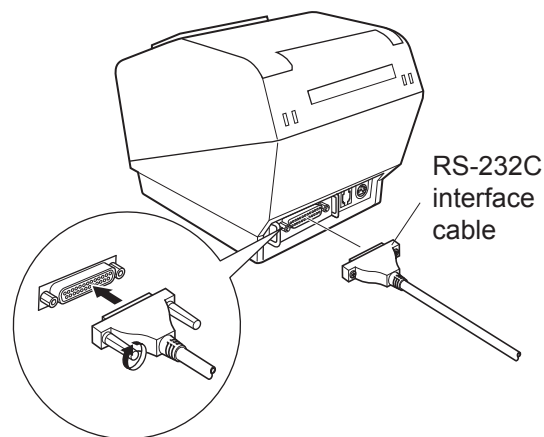

### 3-2-3. USB Interface Cable

Affix the ferrite core onto the USB cable as shown in the illustration below and make sure to pass the cable through the cable support as shown in the illustration.

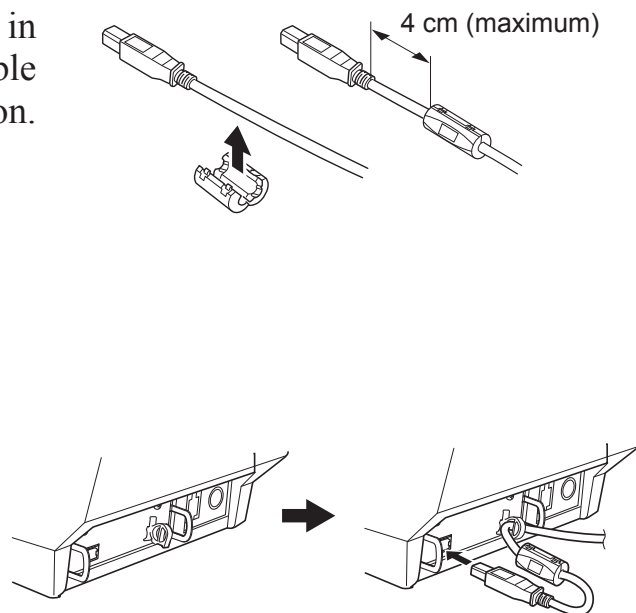

### 3-2-4. Connecting Ethernet Cable

If a ferrite core is included, install the ferrite core onto the Ethernet cable according to the following procedure to prevent electrical noise.

If a ferrite core is not included, perform steps (1) and (5) only.

When using an Ethernet cable that is 10 m or less, shielded cable is recommended.

- (1) Make sure the printer is turned off.
- (2) Install the ferrite core onto the ethernet cable as shown in the illustration below.
- (3) Pass the fastener through the ferrite core.
- (4) Loop the fastener around the cable and lock it. Use scissors to cut off any excess.

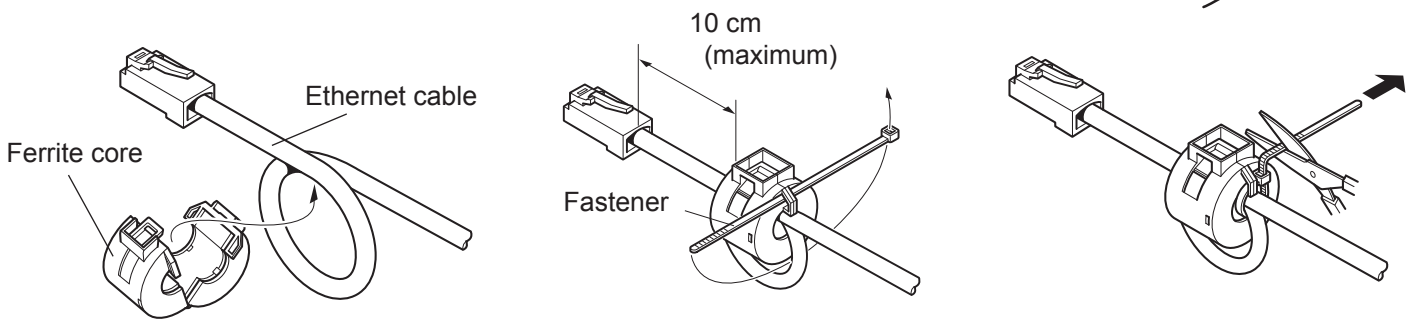

- (5) Connect the interface cable to the connector on the rear panel of the printer.

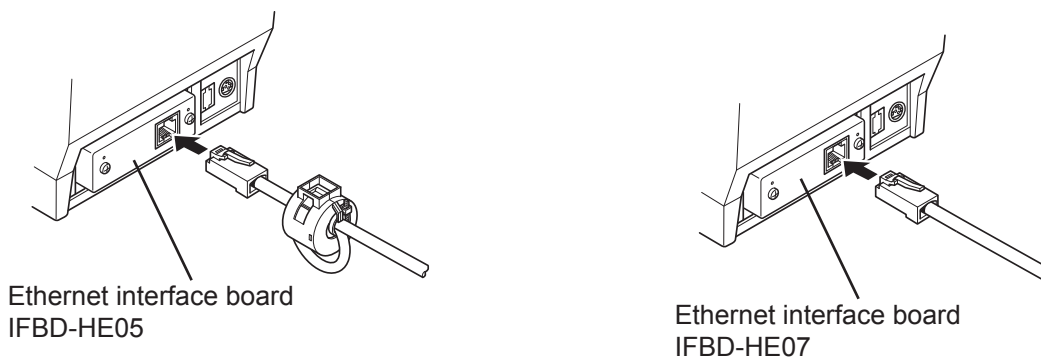

#### Link disconnection detection feature

The Ethernet interface model is equipped with a link disconnection detection feature. If the printer is turned on when an Ethernet cable is not connected to it, the POWER and ERROR lamps are simultaneously turned on and off at 2-second intervals to indicate the disconnection.

Be sure to connect the Ethernet cable from a PC or hub to the printer, and then turn the printer on

### 3-3. Connecting the Optional AC Adapter

**Note:** Before connecting/disconnecting the AC adapter, make sure that power to the printer and all the devices connected to the printer is turned off. Also make sure the power cable plug is disconnected from the AC outlet.

(1) Connect the AC adapter to the power cable.

**Note:** Use only the standard AC adapter and power cable.

(2) Connect AC adapter to the connector on the printer.

(3) Insert the power cable plug into an AC outlet.

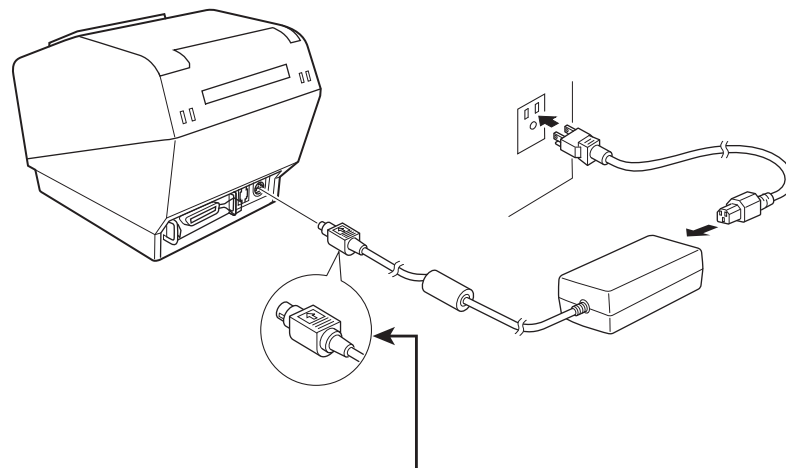

---

**⚠ CAUTION**

*When disconnecting the cable, take hold of the cable connector to pull it out. Releasing the lock makes it easy to disconnect the connector.  
Pulling the cable excessively could cause damage to the connector.*

---

### 3-4. Turning Power On

Make sure that the Power cord has been connected as described in 3-3.

Turn ON the power switch located on the front of the printer.  
The POWER lamp on the control panel will light up.

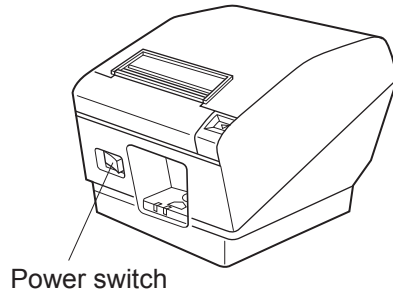

---

#### **⚠ CAUTION**

*We recommend that you unplug the printer from the power outlet whenever you do not plan to use it for long periods. Because of this, you should locate the printer so that the power outlet it is plugged into is nearby and easy to access.*

*When an Switch blind is affixed to the printer above the power switch, the ON/OFF marks of the power switch may be hidden. If this occurs, remove the power cord from the outlet to turn the printer OFF.*

---

### 3-5. Connecting to a Peripheral Unit

You can connect a peripheral unit to the printer using a modular plug. See “Modular plug” on page 53 for details about the type of modular plug that is required. Note that this printer does not come with a modular plug or wire, so it is up to you to obtain one that suits your needs.

---

#### **⚠ CAUTION**

*Make sure that the printer is turned off and unplugged from the AC outlet and that the computer is turned off before making connections.*

---

(1) Connect the peripheral drive cable to the connector on the rear panel of the printer.

---

#### **⚠ CAUTION**

*Do not connect a telephone line into the peripheral drive connector. Failure to observe this may result in damage to the printer.*

*Also, for safety purposes, do not connect wiring to the external drive connector if there is a chance it may carry peripheral voltage.*

---

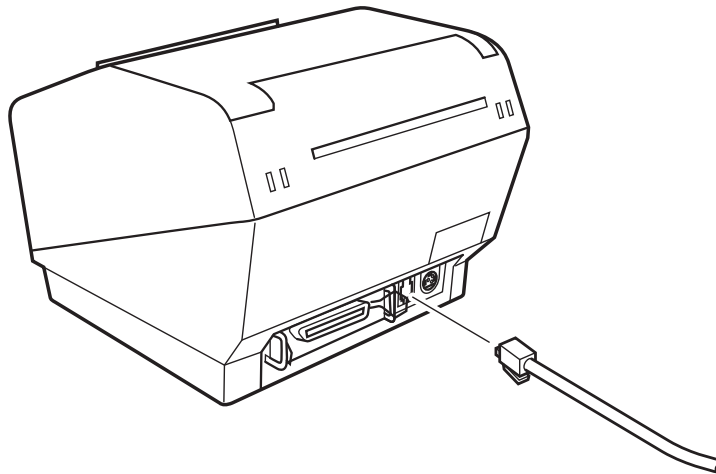

### 3-6. Loading the Paper Roll

Be sure to use paper roll that matches the printer's specification.

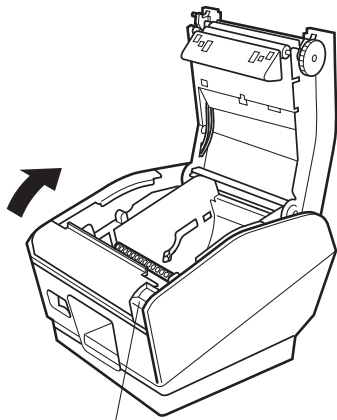

Cover open lever

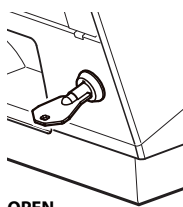

OPEN

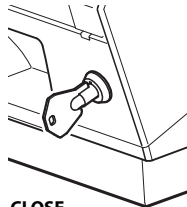

CLOSE

Paper roll

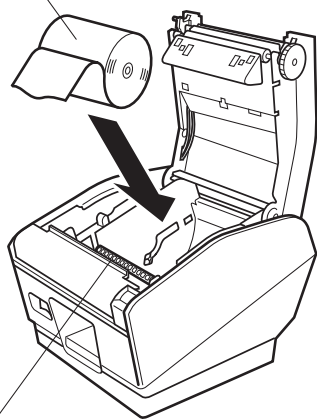

Tension bar

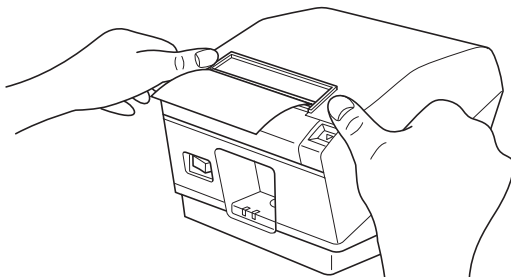

- ① Push the cover open lever and open the printer cover.

For the RX model:

Turn the key under the cover open lever so that the lock is "OPEN." Then, push down on the cover open lever and open the printer cover.

The key cannot be removed when the lock is "OPEN." Before you remove the key, turn it so that the lock is in the "CLOSE" position.

- ② Set the paper roll in the direction as shown, and pull on the leading edge of the paper towards you.



**Note:** Make sure not to pass the paper under the tension bar. In the following condition, remove the tension bar unit in accordance with the procedure described in paragraphs 3-6-1:

- Paper thickness between 100  $\mu\text{m}$  and 150  $\mu\text{m}$

**Note:** When using a paper roll with an 79.5 mm width, attach the paper roll holder in accordance with the procedure described in paragraph 3-6-2.

- ③ Push both sides as shown in order to close the printer cover.

**Note:** When closing the printer cover, make sure both sides close firmly, not just one side.

### 3-6-1. Removing the Tension Bar

When using thermal paper roll, the tension bar unit may or may not be necessary, depending on the paper thickness. If the tension bar unit is unnecessary, remove it in accordance with the procedure indicated below. The tension bar unit is unnecessary when using thermal label paper roll (tack label paper).

Paper thickness between 65 $\mu\text{m}$ and 100 $\mu\text{m}$	Necessary
Paper thickness between 100 $\mu\text{m}$ and 150 $\mu\text{m}$	Unnecessary

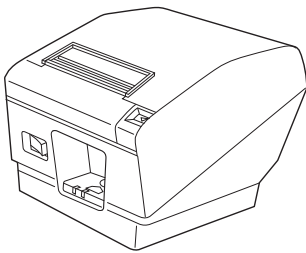

Horizontal

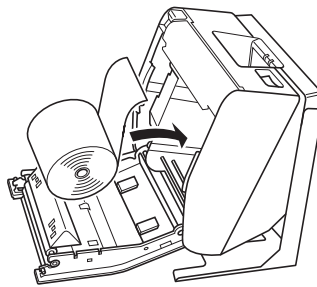

Needed Optional  
Vertical Kit

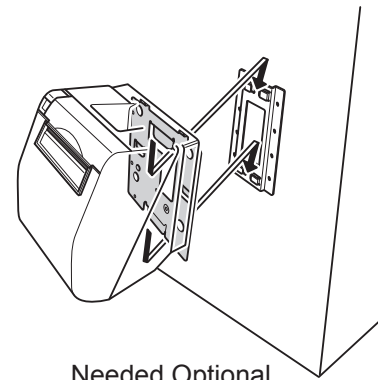

Needed Optional  
Wall-mount Kit

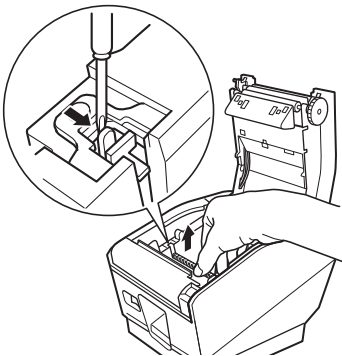

Use a flat head screwdriver as shown to remove the clips at both ends of the tension bar. Then, remove the tension bar unit.



### 3-6-2. Removing the Paper Roll Holder

When using a paper roll with an 79.5 mm width, install the paper roll holder into the groove as shown. When you change the effective print width (paper roll width), change the printer utility's memory switch setting.

For details, see the printer utility help.

**Note:** After using a paper roll with a width of 79.5 mm, do not change to a paper roll with a width of 115.5 mm. This is because the printer head has deteriorated as a result of a portion of the head having been in direct contact with the rubber roller.

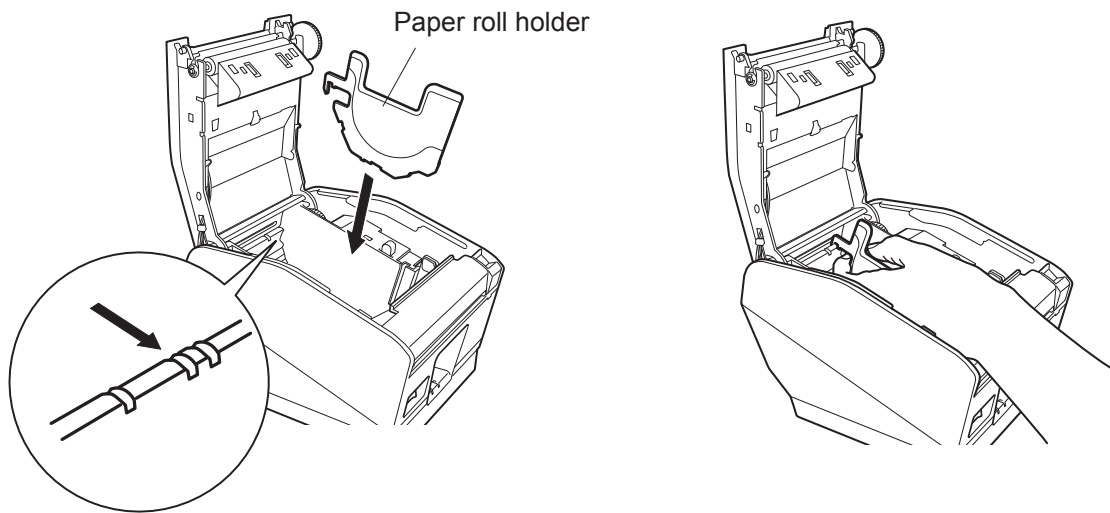

### 3-7. Bluetooth Settings (For Bluetooth Interface Models only)

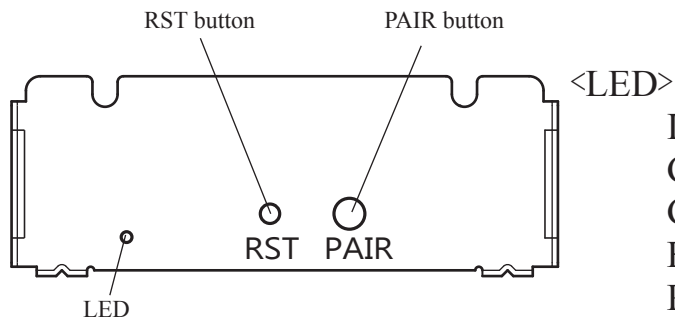

Indicates the status of the Bluetooth interface.  
Green (on): Not connected.  
Green (flashing): Ready to start pairing.  
Blue (on): Connected.  
Purple (flashing): Auto connection ON.

Pair the printer with the master device by following the procedure below.

Compatibility list: <http://www.star-m.jp/prjump/000031.html>

#### 3-7-1. Pairing using SSP (Simple Secure Pairing) [Default]

(1) Working on the master device, tap [Settings] and set [Bluetooth] to ON.

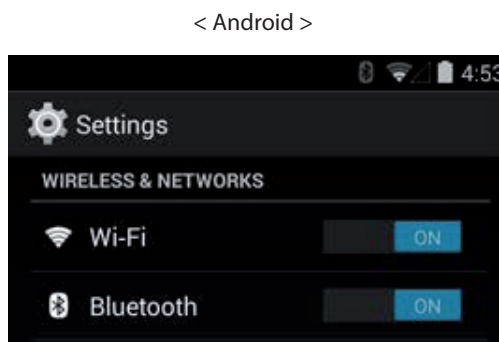

(2) After turning the printer's power switch on, press and hold the PAIR button on the rear interface of the printer for 5 seconds or more, and then release it. The LED will flash green.

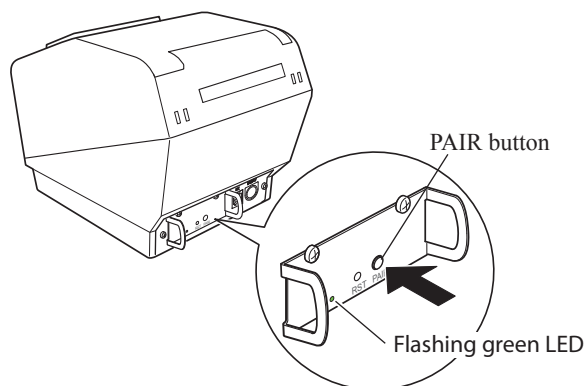

(3) Pairing will be possible for 60 seconds from when the LED begins flashing green. During this time, execute "Search for devices" from the master device and tap the relevant device from the displayed list.

Device name: Star Micronics (default)

(4) In an iOS device, after pairing, the LED will automatically begin flashing blue, and the printer will be automatically connected. In an Android device, the LED turns blue only while data is sent.

(5) Connect to the printer from the master device application and perform printing. If the printing is successful, the pairing process has been completed.

**Note:** The printer performs various processes immediately after connecting to or disconnecting from a master device.

Please wait approximately 0.1 seconds after connecting, and approximately 0.5 seconds after disconnecting, before beginning communications with the printer.

### 3-7-2. Pairing using PIN code

Enter the following information in the master device if it does not support SSP, or when otherwise necessary.

PIN: 1234 (default)

Device name: Star Micronics (default)

It is recommended that you change the PIN code for greater security.

For details regard changing the PIN code, please see the “Software Manual -Star Bluetooth Utility- ”.

### 3-7-3. Auto Connection Function (iOS only)

Each time the wireless connection is disconnected while communicating with upper-level iOS devices including iPad over Bluetooth, it is necessary to move back to the Bluetooth setting screen in the upper-level iOS device and tap the desired printer name again to build a connection. This is an iOS specification.

In order to save this labor, this printer is equipped with the Auto Connection function that automatically requests a connection from an upper-level iOS device that was connected to the printer last time.

The default setting of this function may differ according to the printer model you are using.

Confirm the default settings for your printer, as well as the use examples for ON/OFF settings, and then make the settings to match your purpose.

You can also check the current ON/OFF setting by performing self-printing.

< Confirmation procedure by self-printing >

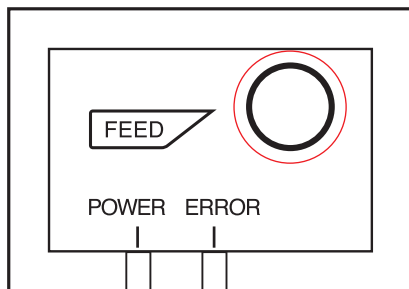

- (1) While the printer cover is closed, hold down the FEED button on the operation panel, and then turn on the power switch.
- (2) Self-printing starts and the settings for F/W version, DIP switch, memory switch, and so on are printed.

Subsequently the interface information is printed and finally the current ON/OFF settings are printed.

**Caution:** If "Auto Connection function" is set to ON when using devices other than iOS, a Bluetooth communication with the printer may fail. To use devices other than iOS, such as the Android/Windows devices, make sure you turn off the "Auto Connection" function before using the printer.

For information on how to set up this function, see "3-7-4. Setting up Auto Connection".

See the table below for details of Auto Connection setting.

	Auto Connection ON	Auto Connection OFF
Reconnecting without changing the master device	After the printer is turned on, it automatically connects to the last master device that was connected.	After turning on the printer, tap this printer's name on the Bluetooth settings screen on the master device.
Changing the connected master device	Disconnect the Bluetooth connection in such a way as to turn OFF the power to the upper-level device automatically connected.  Then, establish a pairing with a desired master device.	After turning on the printer, establish a pairing with a desired master device.
Example (recommended)	When connecting directly to the printer from one master device.	When using the printer with multiple master device.

### 3-7-4. Setting up Auto Connection

#### ◆Setting up from the Main Unit for the TSP800II

**Note:**The following procedure explains how to change the Auto Connection function setting from ON to OFF.

If you want to change it from OFF to ON, please follow the same procedure.

- (1) When paper is loaded in the printer and it is turned on, the [POWER] LED(green) on the front of the printer turns on.
- (2) If you hold down the [RST] button on the back of the printer for at more than five seconds, initial operations are performed in the same way as when the power is turned on, and the LEDs on the front of the printer flash. If you press the [RST] button when the printer is placed upright, place it horizontally again while the LED is flashing.

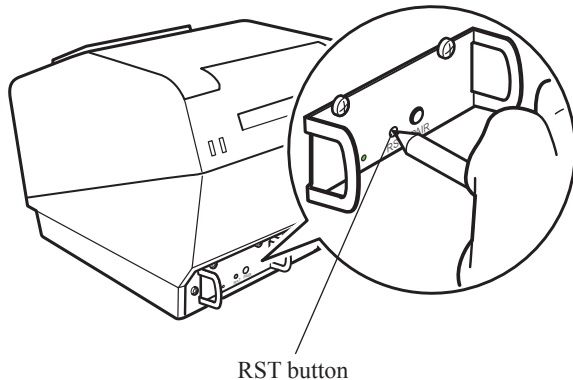

- (3) The following information is printed. After that, turn the printer off and then back on again to set "Auto Connection" to OFF.

```
< Current Setting >
Auto Connection : OFF

To enable this setting, turn
Printer Power OFF and turn ON.
```

- (4) To make sure "Auto Connection" is set to OFF correctly, perform self-printing as described in "3-7-3. Confirmation procedure by self-printing".

#### ◆Setting from the Software

After pairing your device and the TSP800II, change "Auto Connection" in the following application provided by our company.

- iOS: Download "Star Setting Utility" from the following Web site.

<http://www.star-m.jp/prjump/000003.html>

- Android: Download "Star Setting Utility" from the following Web site.

<http://www.star-m.jp/prjump/000004.html>

- Windows: Download "Star Bluetooth Utility" from the following Web site.

<http://www.star-m.jp/prjump/000006.html>

### 3-7-5. Resetting Bluetooth Settings

The following procedure explains how to initialize settings that you have changed such as the PIN code, device name, and so on.

- (1) While inserting a thin object such as the tip of a pen and holding down the RST button on the rear of the printer, turn on the printer's power switch. The POWER LED (green) and the ERROR LED (red) on the front of the printer start flashing.
- (2) Hold down the **RST button for 4 seconds or more** (note 1), and then release it.

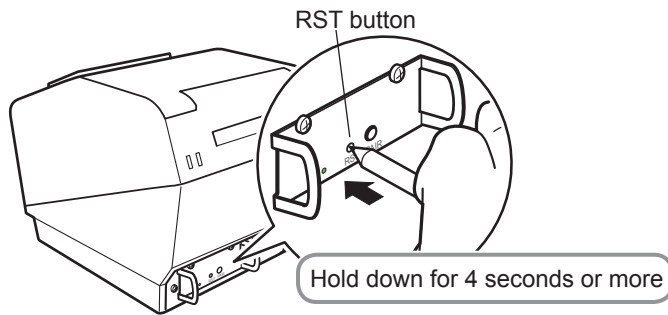

- (3) After you release the RST button, if the LED stops flashing and the POWER LED remains lit green within 12 seconds, initialization is complete. If the LED continues to flash for longer than 12 seconds after releasing the RST button, this indicates that initialization was not successful. Turn off the printer's power and then try again from step 1.
- (4) Turn off the printer's power switch and delete the pairing setup with the higher ranked device.

**Note1:** In step 2, if you do not hold down the RST button for long enough, initialization will not complete correctly.

For F/W Ver2.0, Ver3.0a, and Ver3.0b interfaces

In step 2, you need to **hold down the RST button for 8 seconds or more**.

Also, after finishing steps 1 to 3, to check that initialization was completed correctly, perform self-printing.

If the second sheet (\*\* Bluetooth Information \*\*) is not printed, initialization has not been completed correctly. If this happens, turn off the printer's power, and then try again from step 1.

(You can check the firmware version from the self-printing results. See page 15 for the self-printing procedure.)

**2:** Do not turn off the printer during initialization; otherwise initialization will not complete correctly.

**3:** If initialization is not completed correctly, turn off the printer's power and then try again from step 1.

## 3-8. Setup Precautions

### Caution Symbol



These symbols are located near the thermal print head.

Because the thermal print head is hot immediately after printing, do not touch it. Static electricity can damage the thermal print head. To protect the thermal print head from static electricity, do not touch it.



This symbol is located near the cutter.

Never touch the cutter blade, as you could injure your fingers.



This symbol is located near the peripheral drive connector.

Do not connect this to a telephone.

### **WARNING**

- If you notice smoke or strange odors coming from this product, turn the power switch off immediately, and remove the power cord from the AC outlet. For repairs, contact the dealer that you bought the product from.
- Never attempt to repair the product yourself. Doing so can be dangerous.
- Never disassemble or modify the product. Doing so may result in injury, fire, or electric shock.
- On models that have cutters or tear bars, do not touch the cutter blade or the tear bar.
  - There is a cutter or tear bar inside the paper outlet slot. Never put your hand in the slot regardless of whether or not the printer is in operation.
  - You must open the printer cover to replace paper. However, because the cutter blade or tear bar is located inside of the cover, be careful not to bring your face and hands too close to the blade or tear bar when the cover is open.
- During and immediately after printing, the area around the print head is very hot. Don't touch it because you could be burned.
- Be sure to turn off the printer before performing maintenance on the cutter. Failing to do so is dangerous.

### **CAUTION**

- We recommend that you unplug the printer from the power outlet whenever you do not plan to use the printer for long periods.  
Because of this, you should locate the printer so that the power outlet it is plugged into is nearby and easy to access.
- If an AC cord set is supplied with the product, the power cord that is included has been specially designed for the product.
- Make sure that the printer and the PC are turned off and unplugged from their AC outlets before you make connections.
- Do not connect a telephone line to the peripheral drive connector, which is used for devices such as cash drawers. Doing so may cause the printer to malfunction. Also, for safety purposes, do not connect a wire that may carry excessive voltage to the peripheral drive connector.

- Do not open the printer covers while the printer is printing or cutting.
- Do not pull out paper when the printer cover is closed.
- If liquid or foreign objects (such as coins and paper) enter the inside of the printer, turn the power switch off, disconnect the power cord from the AC outlet, and consult the dealer that you bought the product from. Continuing to use the printer may lead to a short-circuit, which may cause electric shock or fire.
- The heating element and the driver IC of the thermal print head are easily damaged. Do not touch them with metal objects, sandpaper, etc.
- Do not touch the thermal print head heating element. Doing so may make it dirty, which will decrease the printing quality.
- Static electricity can damage the driver IC and other components of the thermal print head. Avoid touching it directly.
- Do not operate the printer if there is moisture (which has been caused by condensation or another factor) on the front surface of the head.
- The printing quality and the thermal print head's service life cannot be guaranteed if paper other than the recommended paper is used.

In particular, thermal paper containing Na<sup>+</sup>, K<sup>+</sup>, or Cl<sup>-</sup> may drastically reduce the service life of the thermal print head.

We recommend that you use paper with the following maximum ion densities: 500 ppm of Na<sup>+</sup>, 150 ppm of K<sup>+</sup>, and 300 ppm of Cl<sup>-</sup>.

For details on recommended thermal paper, see the following webpage.

<http://www.starmicronics.com/support/>

## CAUTION

### **Wireless Communication**

- Do not use the device where using wireless devices is prohibited or may cause interference or danger.
- The radio waves generated by the device may interfere with the operation of electronic medical devices. If you are using any electrical medical device, contact its manufacturer for the restrictions on the use of the device.
- Security functionality for Bluetooth is installed in this product. Configure the security settings according to the manual (available on the Star Micronics website) to reduce the risk of security issues.
- This device supports Bluetooth.

Since this functionality may be limited by local regulations, first review the radio laws specific to the country in which the product will be used.

- Below is a list of laws this device has been approved by. As Star Micronics is committed to constant innovation, revisions may be made without an announcement. Access the Star Micronics website for the latest listing of approvals.
- Please refer to Star Micronics website for the latest information and manuals.



# 4. Consumable Parts

When consumable parts have run out, use those specified in the table below.

**Note:** Access the following URL for the information of the recommended paper.

<http://www.star-m.jp/eng/dl/dl02.htm>

Make sure that the AC adapter specified in the table is used.

Use of consumable parts or AC adapter which are not specified in the table may result in damage to the printer, fire or electric shock.

## 4-1. Thermal Paper Roll

### (1) Paper roll specification

Width: 111.5±0.5 mm or 79.5±0.5 mm

Outer roll diameter: ø100 mm or less

Take up paper roll width:  $112_{-1}^{+0.3}$  mm or  $80_{-1}^{+0.5}$  mm

Thickness: 65~150 µm (when using 115.5 mm width paper)

65~85 µm (when using 79.5 mm width paper)

Core outer/inner diameter

<b>Paper thickness</b>	<b>Core outer</b>	<b>Core inner</b>
65~75 µm	ø18±1 mm	ø12±1 mm
65~75 µm	ø32±1 mm	ø25.4 mm
75~150 µm	ø32±1 mm	ø25.4 mm

Printed surface: Outer edge of roll

Tail end handling: Do not use paste or glue to secure the paper roll or its core.  
Do not fold the tail end of the paper.

## (2) Effective Print Width

Paper Width (mm)	Right / Left Margin (mm)	Effective Print Width (mm)	Number of Print Columns (12 × 24 Font)
115.5 ± 0.5	4	104	69
79.5 ± 0.5	4	72	48

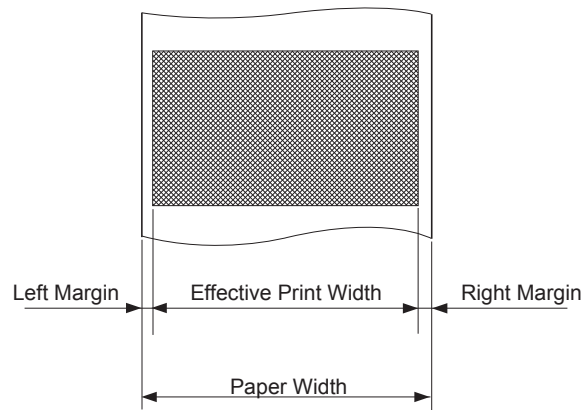

## 4-2. Thermal Label Paper Roll (Tack Label Paper)

### (1) Label paper specification

Backing paper width:	110±0.5 mm
Outer roll diameter:	ø100 mm or less
Take up paper roll width:	112 <sup>+0.3</sup> <sub>-1</sub> mm
Thickness:	Max. 150 µm
Core outer/inner diameter:	core inner diameter ø25.4±1 mm/core outer diameter ø32±1 mm
Printed surface:	Outer edge of roll
Tail end handling:	Do not use paste or glue to secure the paper roll or its core. Do not fold the tail end of the paper.

### (2) Effective Print Width

Paper Width (mm)	Right / Left Margin (mm)	Effective Print Width (mm)	Number of Print Columns (12 × 24 Font)
105 ± 0.5	5	95	63

- Detailed Diagrams of Recommended Tack Label Specifications

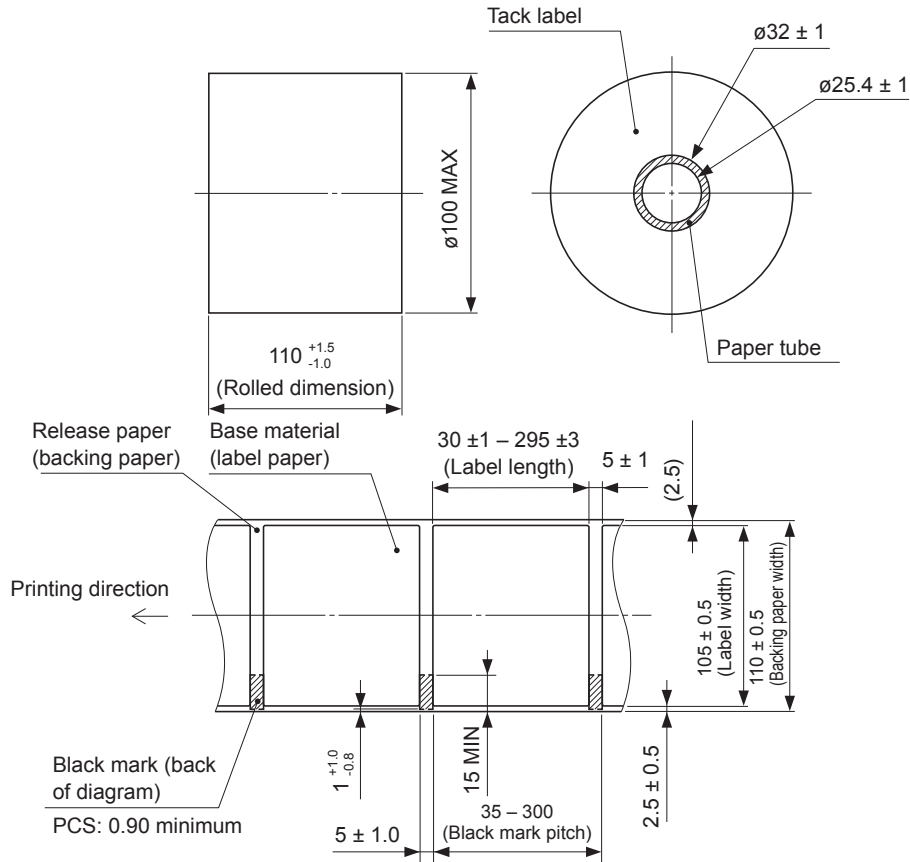

- Detailed Diagram of Effective Printing Range

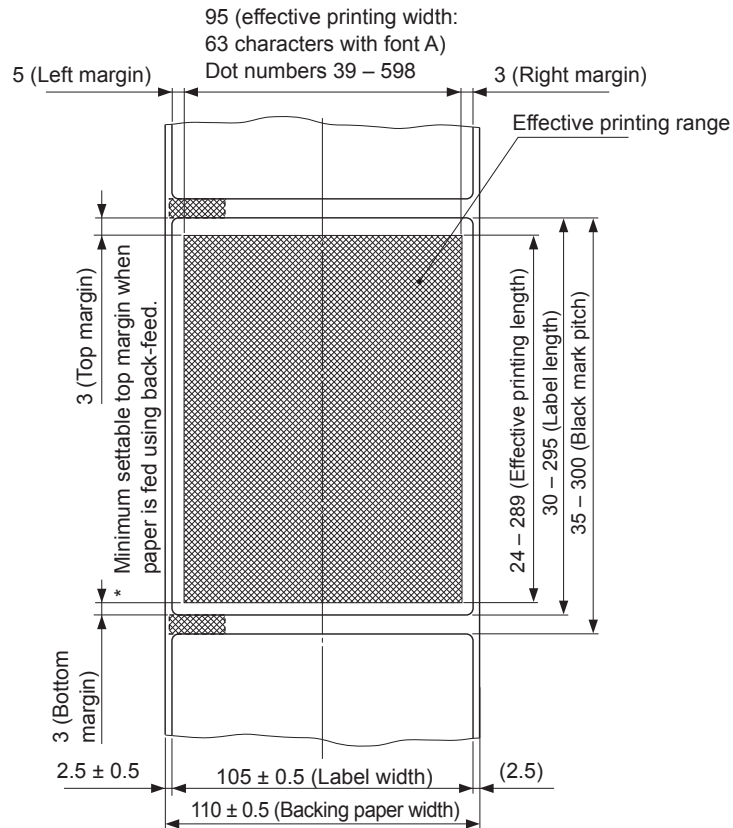

- Cut Position / Printing Line / Black Mark Sensor's Positional Relationship

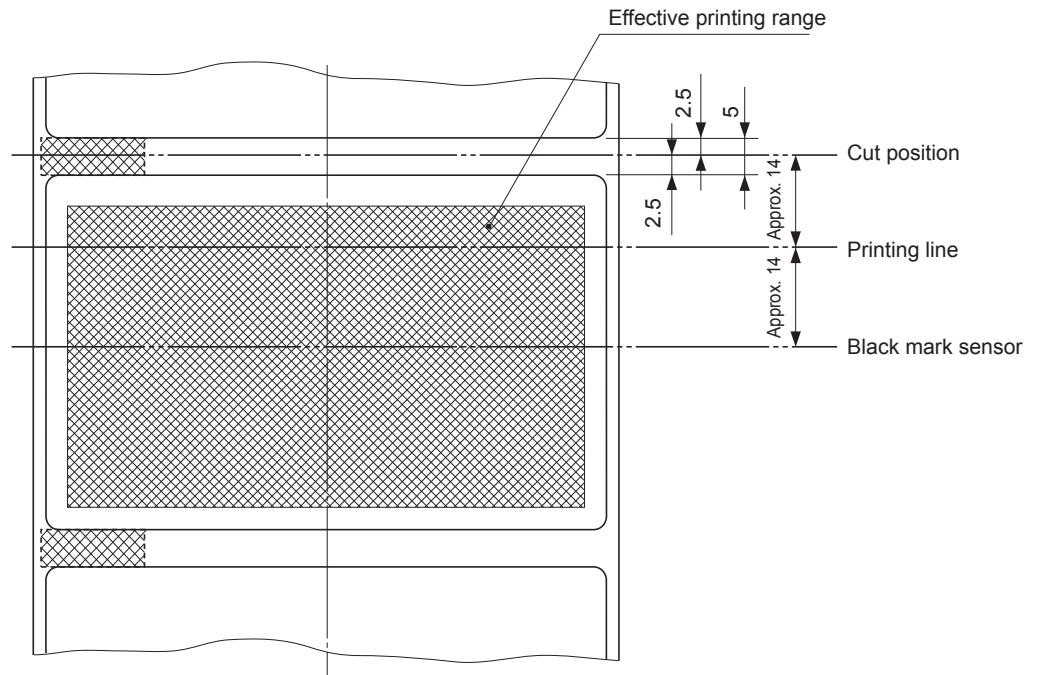

- Min. Label Pitch / Cut Position / Printing Line / Black Mark Sensor's Positional Relationship

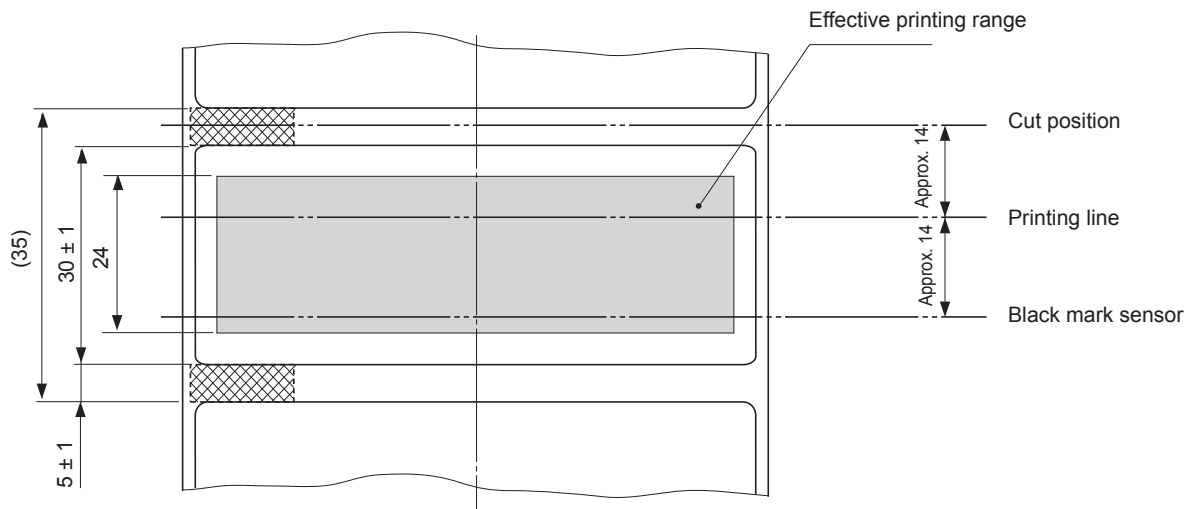

# 5. Control Panel and Other Functions

## 5-1. Control Panel

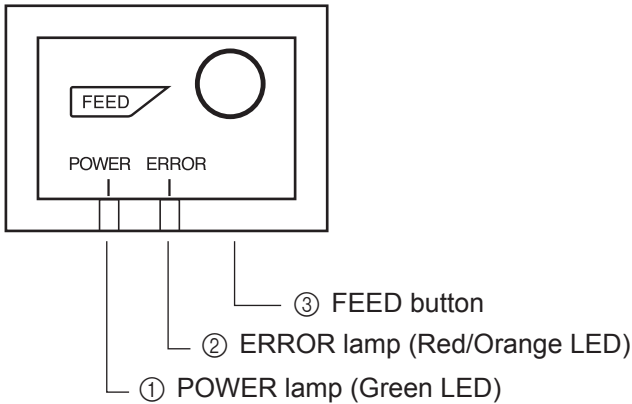

- ① POWER lamp (Green LED)  
When the printer is online, power lamp is ON and ERROR lamp is OFF.
- ② ERROR lamp (Red/Orange LED)  
Indicates various errors in combination with POWER lamp.
- ③ FEED button  
Press the FEED button to feed paper roll.

## 5-2. Errors

### 1) Recoverable errors

Error Description	POWER Lamp	ERROR Lamp	Recovery Conditions
Head high temperature detection	Flashes at 0.5-second intervals	OFF	Automatically recovered after the print head has cooled.
Cover open error	ON	ON (Red)	Automatically recovered by closing the printer cover.
Paper out error	ON	ON (Orange)	Automatically recovered by loading a new paper roll, then closing the printer cover.
Paper near end	ON	Flashes orange lamp at 1 second intervals	Indicators show that the paper end is approaching, but the printer continues to print.
Black mark paper size error	ON	ON (Orange)	Recovered by loading a new paper roll, then closing the printer cover.
Paper cut error	OFF	Flashes red lamp at 0.125 second intervals	Recovered if the cutter returns to the home position after turning the power OFF and ON. (See Notes 1 and 2.)
Link disconnection detection*1	Flashes at 2-second intervals	Flashes at 2-second intervals	Connect an Ethernet cable. For details, see section 3-2-4, "Connecting Ethernet Cable."

\*1 Ethernet interface model only

#### Note:

- 1) If the cutter doesn't return to the home position or doesn't perform the initial movement, it cannot be recovered.
- 2) If the paper is jammed, turn the power off, clear the jammed paper, then turn the power ON.

## 2) Non-recoverable errors

Error Description	POWER Lamp	ERROR Lamp	Recovery Conditions
Flash access error	OFF	Flashes Orange lamp at 0.5-second intervals	This is not a recoverable error.
EEPROM error	OFF	Flashes Red lamp at 0.75-second intervals	This is not a recoverable error.
SRAM error	OFF	Flashes Orange lamp at 1-second intervals	This is not a recoverable error.
Head thermistor error	OFF	Flashes Red lamp at 1.5-second intervals	This is not a recoverable error.
Power voltage error	OFF	Flashes Orange lamp at 2-second intervals	This is not a recoverable error.

**Note:**

- 1) If a non recoverable error occurs, turn the power OFF immediately.
- 2) When Power supply error occurs, there is a possibility that the power supply unit has a trouble.  
For other non recoverable errors, please consult the dealer for repairs.

# 6. Adjusting the Sensor

This printer is equipped with the following two paper sensors:

- PE and BM (Paper End and Black Mark) Sensor  
Detects whether a roll paper is loaded in the printer.  
In addition, detects the Black Mark that is pre-printed on the paper's print side.
- NE (Near End) sensor  
Detects whether the roll paper is nearing its end.

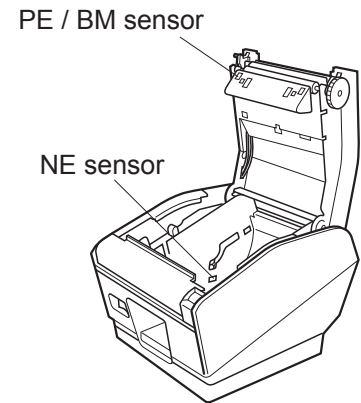

## 6-1. Adjusting the Near End Sensor Position

Use the following procedure to adjust the near-end sensor so it is compatible with the size of paper roll you are using.

However, for vertical or wall-mount use, keep the adjuster fixed to level 3, without changing its position.

- ① Open the printer cover.
- ② Determine the diameter of the paper roll you are using and find the required setting in the table below.
- ③ Insert the tip of a ballpoint pen or similar object into the hole of the adjuster, and then push and slide the adjuster to the desired setting.

When changing the setting, make sure that the position of the hole is aligned with the alignment mark indicated by the arrow.

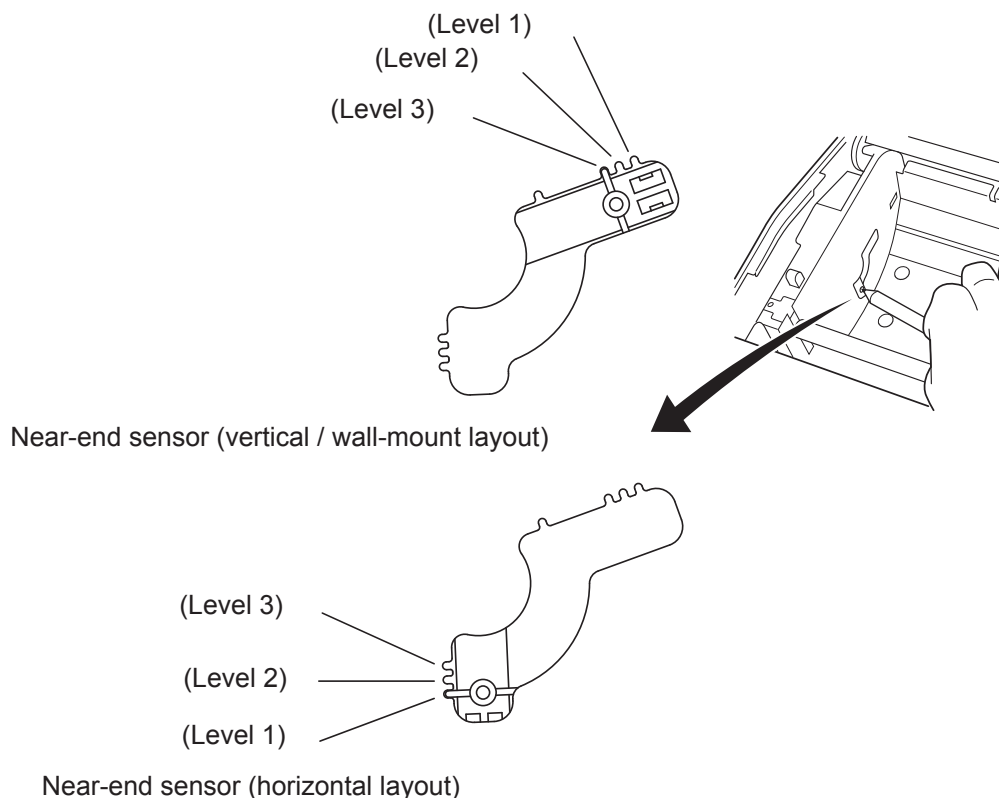



## Adjustment value according to the paper you are using

Paper thick-ness (μm)	When using the paper roll with a core whose inside diameter (A):ø12, outside diameter (B):ø18					
	Detected diameter (C) (Approx. mm)			Remained paper length (Approx. m)		
	Level 1	Level 2	Level 3	Level 1	Level 2	Level 3
65	ø23	ø27	ø31	2.5	4.9	7.7
75				2.1	4.2	6.7

Paper thick-ness (μm)	When using the paper roll with a core whose inside diameter (A): ø25.4, outside diameter (B):ø32					
	Detected diameter (C) (Approx. mm)			Remained paper length (Approx. m)		
	Level 1	Level 2	Level 3	Level 1	Level 2	Level 3
65	ø36	ø40	ø44	2.8	6.4	10.4
75				2.4	5.5	9.0
85				2.1	4.9	7.9
95				1.9	4.4	7.1
105				1.7	4.0	6.4
130				1.4	3.2	5.2
150				1.2	2.8	4.5

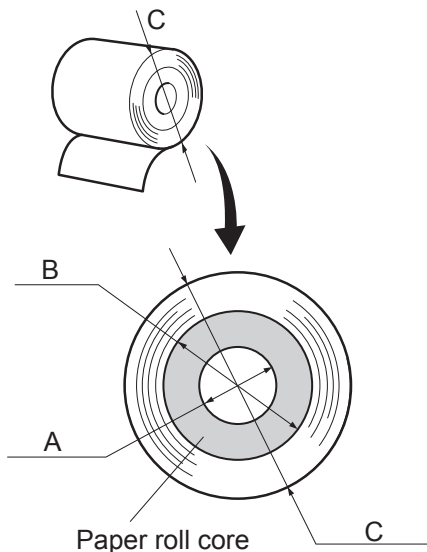

### Note:

- 1) The adjuster is factory-set at level 1 on the horizontal layout and level 3 on the vertical/wall-mount layout.
- 2) The detected diameter and remained paper length given above are calculated values, and there may be some variances depending on the rolled state of the paper or the actual mechanism.
- 3) If thick paper is used (paper thickness between 100 μm and 150 μm), the paper roll may loosen and cause variances in the detected values. Therefore, set the adjuster to Level 3 for horizontal layout.
- 4) The near end sensor doesn't correspond to the thermal label paper roll (tack label paper).

## 6-2. PE and BM ( Paper End and Black Mark ) Sensor Adjustment

The sensitivity of the sensor is calibrated at the factory, so sensor adjustment is not necessary under ordinary conditions. However, you may need to make adjustments when using non-recommended paper or when the surrounding environment prevents the sensor from working properly.

- ① Make sure that the printer is turned OFF.
- ② Open the printer cover, load the roll paper, and set the printer to the "paper present" state.
- ③ Remove the screw from the DIP switch cover on the bottom of the printer. Then take off the DIP switch cover, as shown in the illustration below.
- ④ Using the tip of a ballpoint pen or a similar tool, set the DIP switches as follows: DIP SW1-4 OFF, DIP SW1-5 ON, DIP SW1-6 ON, and DIP SW1-7 ON. Turn the printer power ON. The lamps on the control panel will flash, and the printer will enter the sensor adjustment mode.
- ⑤ Using a small slot screwdriver, turn VR3 as shown below, and adjust it so that the green POWER LED and the red ERROR LED light.
- ⑥ Turn the printer power OFF, and restore the following DIP switches to their original settings: DIP SW1-4, DIP SW1-5, DIP SW1-6, and DIP SW1-7.

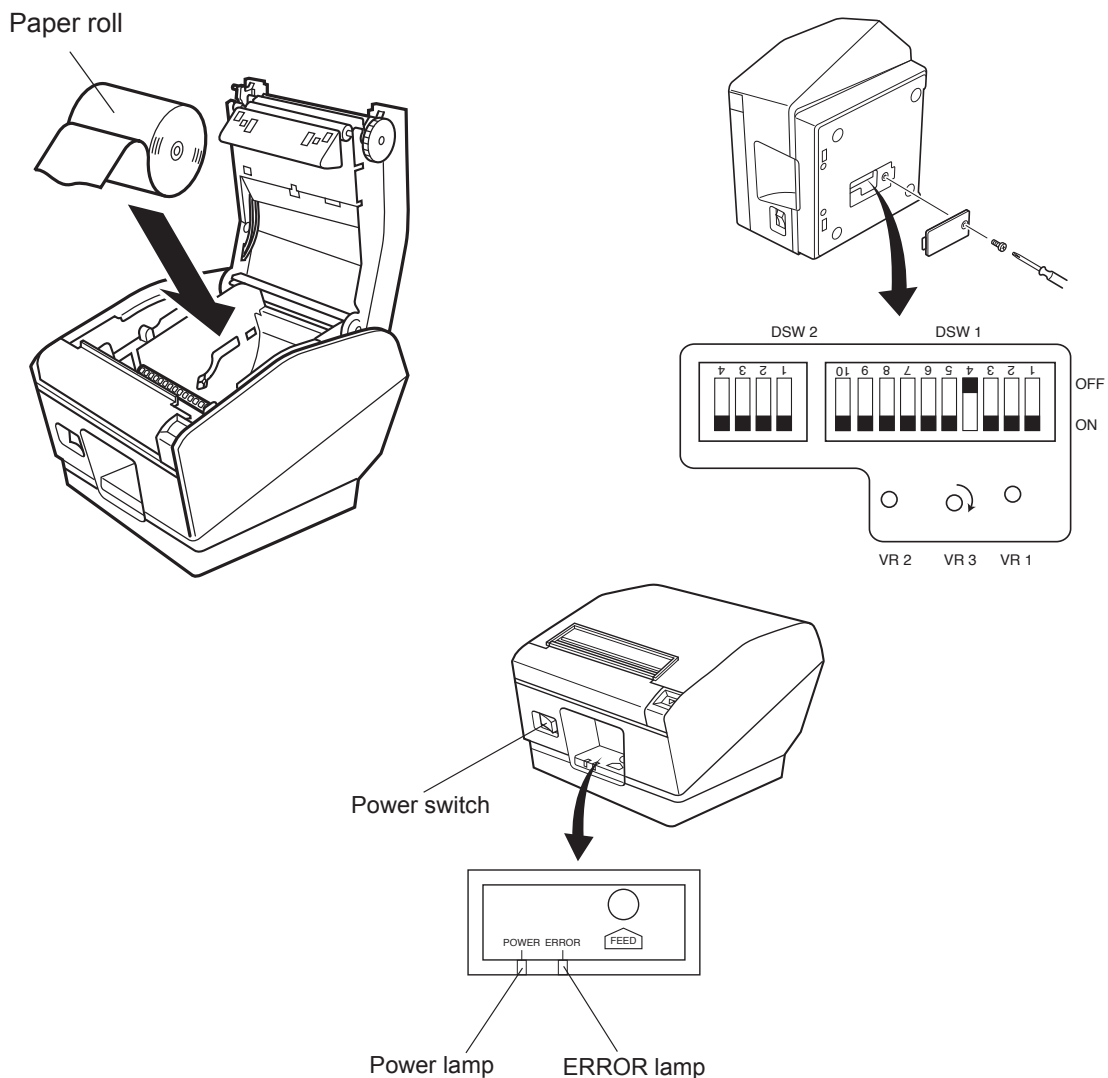

### 6-3. NE (Near End) Sensor Adjustment

The sensitivity of the sensor is calibrated at the factory, so sensor adjustment is not necessary under ordinary conditions. However, you may need to make adjustments when using non-recommended paper or when the surrounding environment prevents the sensor from working properly.

- ① Make sure that the printer is turned OFF.
- ② Open the printer cover, remove the roll paper and set the printer to the "paper absent" state.
- ③ Remove the screw from the DIP switch cover on the bottom of the printer. Then take off the DIP switch cover, as shown in the illustration below.
- ④ Using the tip of a ballpoint pen or a similar tool, set the DIP switches as follows: DIP SW1-4 OFF, DIP SW1-5 OFF, DIP SW1-6 ON, and DIP SW1-7 ON. Turn the printer power ON. The lamps on the control panel will flash, and the printer will enter the sensor adjustment mode.
- ⑤ Use a small slot screwdriver to turn VR2 clockwise as far as it will go. If the POWER LED lights, go to step 6. If the POWER LED does not light, turn VR2 so that both the ERROR LED and the POWER LED light.
- ⑥ Turn the printer power OFF, and restore the following DIP switches to their original settings: DIP SW1-4, DIP SW1-5, DIP SW1-6, and DIP SW1-7.

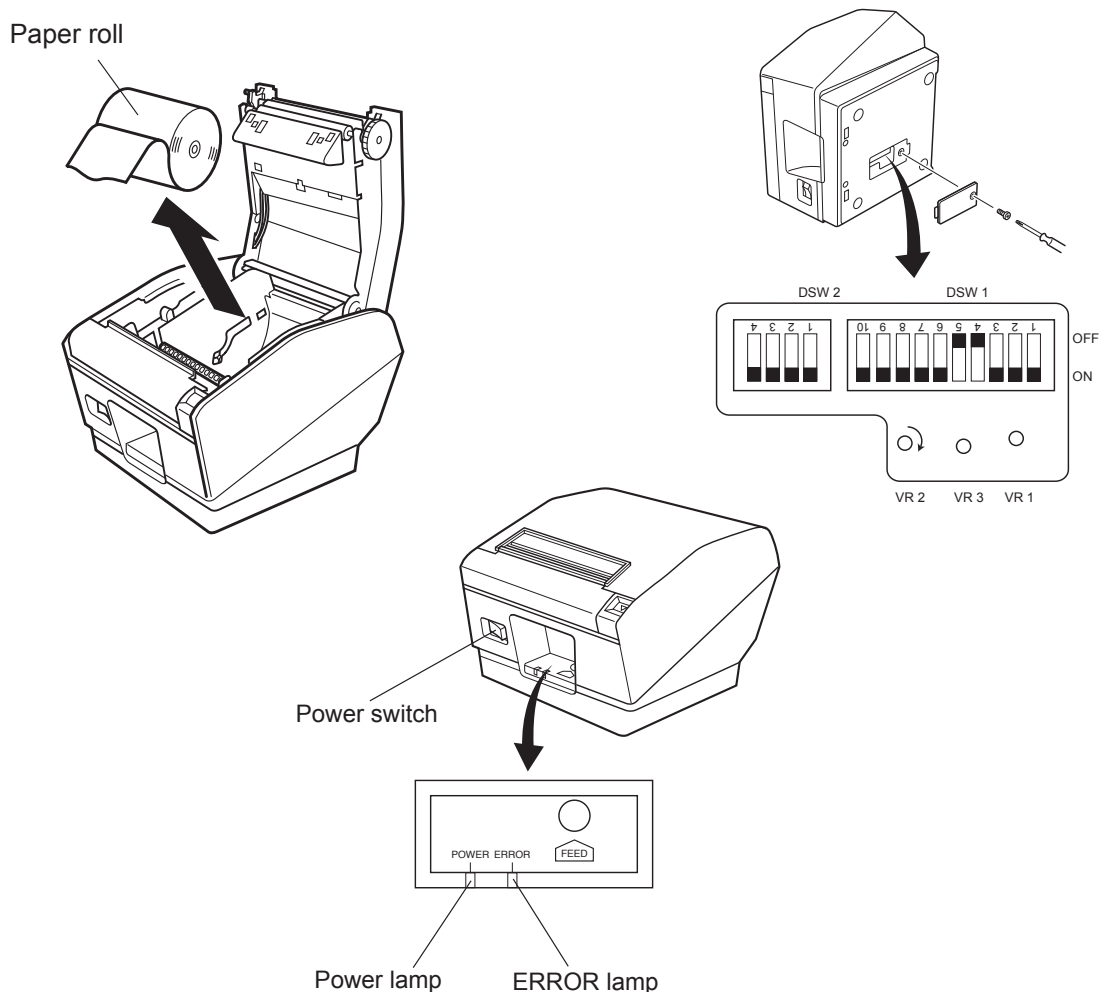

# 7. Preventing and Clearing Paper Jams

## 7-1. Preventing Paper Jams

The paper should not be touched during ejection and before it is cut.

Pressing or pulling the paper during ejection may cause a paper jam, paper cutting failure or line feed failure.

## 7-2. Removing Paper Jam

If a paper jam occurs, clear it as described below.

(1) Set the power switch to off to turn off power to the printer.

(2) Push the lever toward you to open the printer cover.

(3) Remove the jammed paper.

**Note 1:** To prevent parts such as the thermal head or the rubber roller from damage or deformation, do not forcibly pull on the paper with the printer cover closed.

**Note 2:** If label paper gets jammed, the glue from the labels could stick to the parts. If this occurs, make sure to wipe them clean of the glue.

(4) Position the paper roll straight and close the printer cover gently.

**Note 1:** Make sure that the paper is positioned straight. If the printer cover is closed with the paper skewed, a paper jam may result.

**Note 2:** Lock the printer cover by pressing down on the sides. Do not try to close it by pressing down on the centre. The cover may not lock properly.

(5) Set the power switch to on to turn on power to the printer. Make sure that the ERROR LED is not lit.

**Note:** While the ERROR LED is lit, the printer will not accept any commands such as the print command, so make sure that the printer cover is locked properly.

# 8. Periodical Cleaning

Printed characters may become partially unclear due to accumulated paper dust and dirt. To prevent such a problem, paper dust collected in the paper holder and paper transport section and on the surface of the thermal head must be removed periodically.

Such cleaning is recommended to be carried out once six month or one million lines. If the printer uses label paper, clean it on a monthly basis or after printing approximately 200,000 lines.

## 8-1. Cleaning the Thermal Head

To remove the dark paper dust that has accumulated on the thermal head surface, wipe it clean with cotton swab (or soft cloth) dipped in alcohol (ethanol, methanol, or isopropyl alcohol). If the printer uses label paper, wipe it clean of the glue that may have accumulated.

**Note 1:** The thermal head is easily damaged, so clean it with a soft cloth, taking care not to scratch it.

**Note 2:** Do not attempt to clean the thermal head immediately after printing, when the thermal head is hot.

**Note 3:** Beware of the risk of damaging the thermal head as a result of static electricity that may be created during cleaning.

**Note 4:** Turn the power ON only after the alcohol has dried completely.

## 8-2. Cleaning the Rubber Roller

Use a dry, soft cloth to wipe off the dust that may have accumulated on the rubber roller.

## 8-3. Cleaning the Sensors and the Surrounding Areas

Clean the sensors (mainly the reflector type sensors) of debris, dust, paper particles, glue, etc. that may have accumulated.

## 8-4. Cleaning the Paper Holder and the Surrounding Area

Clean the paper holder of debris, dust, paper particles, glue, etc. that may have accumulated.

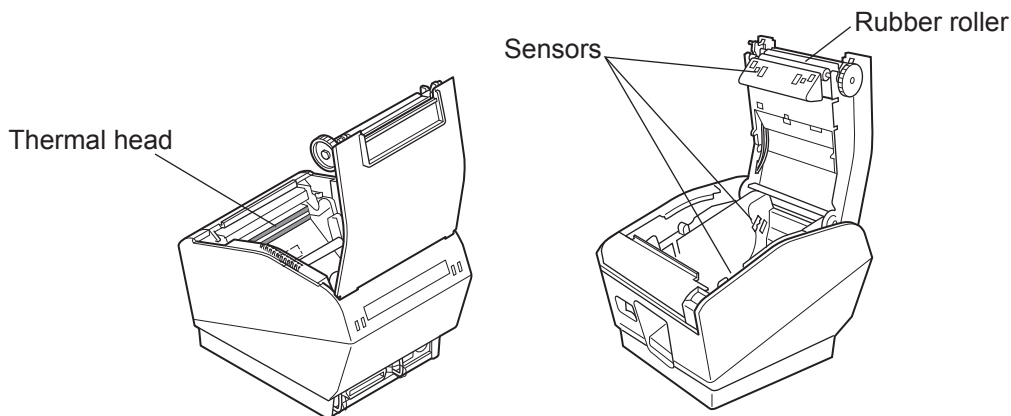

English:	Hereby, STAR MICRONICS CO.,LTD. declares that this Wireless Device is in compliance with the essential requirements and other relevant provisions of Directive 1999/5/EC.	Slovensky: [Slovak]	STAR MICRONICS CO.,LTD. týmto vyhlasuje, že Wireless Device spĺňa základné požiadavky a všetky príslušné ustanovenia Smernice 1999/5/ES.
Deutsch: [German]	Hiermit erklart STAR MICRONICS CO.,LTD., dass sich das Gerat Wireless Device in ubereinstimmung mit den grundlegenden Anforderungen und den ubrigen einschlagigen Bestimmungen der Richtlinie 1999/5/EG befindet.	Slovensko: [Slovenian]	STAR MICRONICS CO.,LTD. izjavlja, da je ta Wireless Device v skladu z bistvenimi zahtevami in ostalimi relevantnimi določili direktive 1999/5/ES.
Svenska: [Swedish]	Harmed intygat STAR MICRONICS CO.,LTD. att denna Wireless Device star i overensstammelse med de vasentliga egenskapskrav och ovriga relevanta bestammelser som framgar av direktiv 1999/5/EG.	esky: [Czech]	STAR MICRONICS CO.,LTD. tımto prohlašuje, že tento Wireless Device je ve shode se zakladnımi požadavky a dalšımı prıslušnımı ustanovenımı smernice 1999/5/ES.
Espa˜ol: [Spanish]	Por medio de la presente STAR MICRONICS CO.,LTD. declara que el Wireless Device cumple con los requisitos esenciales y cualesquiera otras disposiciones aplicables o exigibles de la Directiva 1999/5/CE.	Magyar: [Hungarian]	Alulırott, STAR MICRONICS CO.,LTD. nyilatkozom, hogy a Wireless Device megfelel a vonatkozo alapveto kovetelmenyeknek es az 1999/5/EK iranyelv egyeb eloirasainak.
Portugues: [Portuguese]	STAR MICRONICS CO.,LTD. declara que este Wireless Device esta conforme com os requisitos essenciais e outras disposioes da Directiva 1999/5/CE.	lgariski: [Bulgarian]	това Безжично устройство е в съответствие със задължителните изисквания и другите приложими разпоредби на Директива 1999/5/EO.
Franais: [French]	Par la presente STARMICRONICS CO.,LTD. declare que l'appareil Wireless Device est conforme aux exigences essentielles et aux autres dispositions pertinentes de la directive 1999/5/CE.	Polski: [Polish]	Niniejszym STAR MICRONICS CO.,LTD. ošwiadcza, że Wireless Device jest zgodny z zasadniczymi wymogami oraz pozostałymi stosownymi postanowieniami Dyrektywy 1999/5/WE.
Suomi: [Finnish]	STAR MICRONICS CO.,LTD. vakuuttaa taten etta Wireless Device tyypinen laite on direktiivin 1999/5/EY oleellisten vaatimusten ja sita koskevien direktiivin muiden ehtojen mukainen.	Malti: [Maltese]	Hawnhekk, STAR MICRONICS CO.,LTD., jiddikjara li dan Wireless Device jikkonforma mal-ħtiġijiet essenzjali u ma provvedimenti oħrajn rilevanti li hemm fid-Dirrettiva 1999/5/KE.
Italiano: [Italian]	Con la presente STAR MICRONICS CO.,LTD. dichiara che questo Wireless Device e conforme ai requisiti essenziali ed alle altre disposizioni pertinenti stabilite dalla direttiva 1999/5/CE.	Latviski: [Latvian]	Ar šo STAR MICRONICS CO.,LTD. deklare, ka Wireless Device atbilst Direktivas 1999/5/EK butiskajam prasibam un citiem ar to saistıtajiem noteikumiem.
Dansk: [Danish]	Undertegnede STAR MICRONICS CO.,LTD. erklerer herved, at folgende udstyr Wireless Device overholder de vasentlige krav og ovrige relevante krav i direktiv 1999/5/EF.	Lietuviu : [Lithuanian]	Šiuo STAR MICRONICS CO.,LTD. deklaruoja, kad šis Wireless Device atitinka esminius reikalavimus ir kitas 1999/5/EB Direktyvos nuostatas.
Nederlands: [Dutch]	Hierbij verklaart STAR MICRONICS CO.,LTD. dat het toestel Wireless Device in overeenstemming is met de essentiele eisen en de andere relevante bepalingen van richtlijn 1999/5/EG.	Norsk : [Norwegian]	STAR MICRONICS CO.,LTD. erklerer herved at utstyret Wireless Device er i samsvar med de grunnleggende krav og ovrige relevante krav i direktiv 1999/5/EF.
Eesti: [Estonian]	Kaesolevaga kinnitab STAR MICRONICS CO.,LTD. seadme Wireless Device vastavust direktiivi 1999/5/EU pohinouetele ja nimetatud direktiivist tulenevatele teistele asjakohastele satetele.	Romana : [Romanian]	Prin prezenta STAR MICRONICS CO., LTD. declara ca acest dispozitiv este conform cu cerințele esențiale și alte prevederi relevante ale directivei 1999/5/CE.
Ελληνικη: [Greek]	ΜΕ ΤΗΝ ΠΑΡΟΥΣΑ STAR MICRONICS CO.,LTD. ΔΗΛΩΝΕΙ ΟΤΙ Wireless Device ΣΥΜΜΟΡΦΩΝΕΤΑΙ ΠΡΟΣ ΤΙΣ ΟΥΣΙΩΔΕΙΣ ΑΠΑΙΤΗΣΕΙΣ ΚΑΙ ΤΙΣ ΛΟΙΠΕΣ ΣΧΕΤΙΚΕΣ ΔΙΑΤΑΞΕΙΣ ΤΗΣ ΟΔΗΓΙΑΣ 1999/5/EK.	Hrvatski : [Croatian]	Ovime Star Micronics CO., LTD. izjavljuje da je bežični uređaj u skladu s osnovnim zahtjevima i drugim važnim odredbama direktive 1999/5/EZ.

**Italia:** l'uso pubblico e soggetto ad autorizzazione generale da parte del rispettivo provider di servizi.

**Norge:** Dette avsnittet gjelder ikke det geografiske omradet innenfor en radius pa 20 km fra sentrum av Ny-alesund.

*This statement will be applied only for the printers marketed in Europe.*



STAR MICRONICS CO.,LTD. Head Office  
20-10 Nakayoshida, Suruga-ku, Shizuoka-shi, Shizuoka, 422-8654, Japan  
Tel. + 81-54-263-1111 Fax. + 81-54-263-1057

STAR Quality Technical Center  
18-12 Nakayoshida, Suruga-ku, Shizuoka-shi, Shizuoka, 422-8001, Japan  
Tel. + 81-54-263-1303 Fax. + 81-54-263-6650

## Declaration of Conformity

We declare, under our solo responsibility, that the product to which this declaration relates complies with the provisions of following European Directives:

**1999/5/EC**  
**2014/30/EU**  
**2014/35/EU**  
**2011/65/EU , 2015/863**

harmonised standard

RADIO : **EN 300 328 V1.9.1:2015**  
EMC : **EN 301 489-1 V1.9.2:2011**  
**EN 301 489-17 V2.2.1:2012**  
**EN 55032:2012 Class B (CISPR 32:ed1.0-2012)**  
**EN 61000-3-2:2014 (IEC 61000-3-2:2014)**  
**EN 61000-3-3:2013 (IEC 61000-3-3:2013)**  
**EN 55024:2010 (CISPR 24:ed2.0-2010)**  
SAFETY : **EN 60950-1:2006 / A2:2013**  
**EN 62311:2008**  
**EN 62479:2010**  
ENVIRONMENT: **EN 50581:2012**

Manufacturer's Name **Star Micronics Co.,Ltd.**  
Manufacturer's Address **20-10 Nakayoshida, Suruga-ku, Shizuoka-shi,  
Shizuoka 422-8654 Japan**

Importer's Name **Star Micronics Europe Ltd.**  
Importer's Address **Star House, Peregrine Business Park, Gomm Road,  
High Wycombe, Bucks. HP13 7DL, U.K.**

Type of Equipment **Thermal Printer**  
Model Name **TSP800**  
Ref. Radio Report No. **F161591E1, F161591E2**  
Ref. EMC Report No. **F111592E1 ,  
92-152-EMC , 91-113-EMC , 91-002-16-EMC , 90-050-EMC**  
Ref. Safety Cert. No. **91-113-Safety ,  
73507094 Rev.2,3,4,5 , S161188E1**  
Ref. Environ. Report No. **TSP800-RoHS-02**

Place High Wycombe - U.K.  (Signature)

Date 13-02-2017 David Pearce (Full Name)

Year of 1st CE mark '00 Technical Director (Position)



URL: <http://www.star-m.jp/eng>

Rev. 1.6