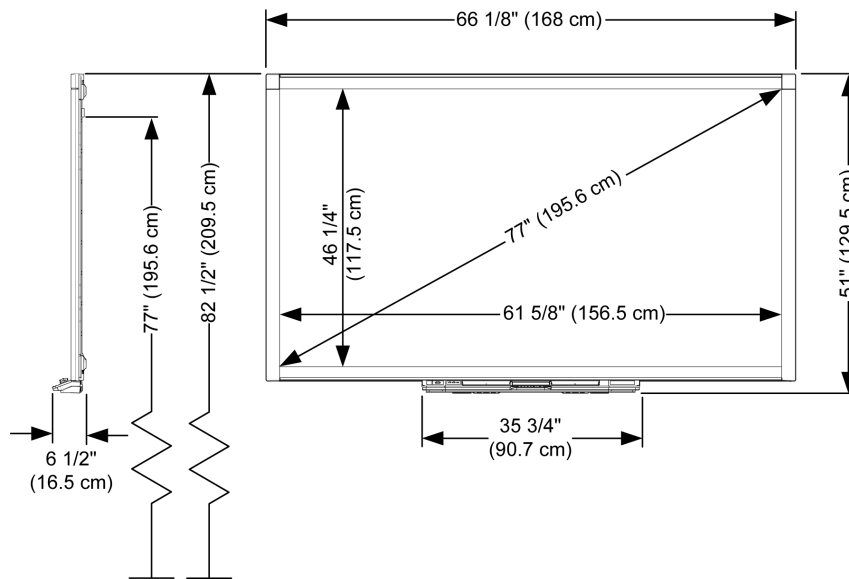

Specifications

SMART Board® interactive whiteboard

Model SB880E

Dimensions and weights¹Dimensions²**SMART Board 880E interactive whiteboard****Weight**

47 lb. (21.5 kg)

Shipping dimensions4 1/2" W × 55 7/8" H × 76 1/4" D
(11.4 cm × 141.9 cm × 193.7 cm)**Shipping weight**

62 lb. 13 oz. (28.5 kg)

Accessory Kit (includes pen tray)**Weight**

12 lb. (5.5 kg)

Shipping dimensions40 1/8" W × 7" H × 3 7/8" D
(102 cm × 17.7 cm × 9.8 cm)**Extended control panel (ECP)****Dimensions**6 5/8" W × 2 1/8" H × 4 5/8" D
(16.8 cm × 5.5 cm × 11.9 cm)**Weight**

5 lb 11 oz. (2.6 kg)

Shipping dimensions16 1/2" W × 14" H × 3" D
(41.9 cm × 35.6 cm × 7.6 cm)**Remote control****Dimensions**1 5/8" W × 3 3/8" H × 1/4" D
(4.1 cm × 8.6 cm × 0.6 cm)¹All dimensions ± 1/8" (0.3 cm). All weights ± 2 lb. (0.9 kg).²The height of SMART Board 800 series interactive whiteboards manufactured before June 2015 is 53 3/8" (135.6 cm).

Standard features

| | |
|--------------------------------|---|
| Software | SMART Notebook® collaborative learning software including SMART Product Drivers |
| Computer requirements | A computer or laptop with either a Windows® operating system or Mac operating system software and SMART Notebook software installed. For a complete list of computer requirements, go to smarttech.com/downloads and browse to the latest SMART Notebook release notes applicable to your operating system. ³ |
| Touch and gestures | Perform mouse functions with your finger and write and erase digital ink with a pen tray pen or the eraser. The Object Awareness feature enables you to pick up a pen, and then write, select or erase without replacing the pen. This interactive whiteboard also features gesture capability, providing a natural and flexible way to interact with content. |
| Multitouch capabilities | <ul style="list-style-type: none"> • Users can interact with the interactive whiteboard using the included pens or other objects, or by using their fingers to write and perform gestures. • Support for four simultaneous touches enables up to four users to interact with the interactive whiteboard. |
| SMART Ink™ | Smooths out the appearance of the digital ink, improving the legibility of your handwriting. The ink becomes an object you can move and manipulate. |
| Lockable pen option | Hold down a pen color button on the pen tray until its light flashes to lock the interactive whiteboard in pen mode. In this mode you can use any device as a pen. Early education students and students with special needs can use an object like a tennis ball to write more easily on the surface. |
| Pen tray | <ul style="list-style-type: none"> • Optical sensors in the pen tray detect when you lift a pen or eraser from the tray. Color buttons on the pen tray enable you to select pen color. • Removable end caps for optional accessories |
| Pen and eraser | Two ergonomic pens with a comfort grip and a rectangular eraser |
| Touch resolution | Approximately 4000 × 4000 |
| Screen surface | The hard-coated steel surface is durable, optimized for projection, compatible with dry-erase markers and easily cleaned. |
| Digitizing technology | Four-camera DViT® (Digital Vision Touch) technology |
| Frame finish | Light gray (approximates PANTONE® Cool Gray 6C) |
| Wall-mount bracket | 32" (81.3 cm) wide bracket with five screws and toggle bolt anchors to support a wall-mounted interactive whiteboard |
| Power requirements | 6' (1.8 m) power cable and 6" (15 cm) Y-cable. Power consumption is less than 7 W (100V to 240V AC, 50/60 Hz, 5V DC 2.0A) |

³A digital projector isn't included with this model of SMART Board interactive whiteboard. To take advantage of all interactive features, you must integrate a supported digital projector.

Temperature specifications

| | |
|------------------|--|
| Storage | -40°F to 120°F (-40°C to 50°C) |
| Operating | 41°F to 95°F (5°C to 35°C) with up to 80% humidity, non-condensing |

Certification and compliance

Regulatory certification CE, CSA (U.S./Canada) and FCC

Environmental compliance

| | |
|----------------|---------------------------------|
| China | EIP |
| European Union | REACH, RoHS, WEEE and Packaging |
| U.S. | Packaging |

Warranty

Interactive whiteboard The interactive whiteboard has a two-year limited equipment warranty or a five-year limited equipment warranty upon registration. See warranty documents for details.

Accessories The accessories have a one-year warranty.

Purchasing information

NOTE

A digital projector isn't included with this model of SMART Board interactive whiteboard. To take advantage of all interactive features, integrate a digital projector. The SMART Board 880E interactive whiteboard supports the following digital projectors, available from your SMART reseller:

- Epson® PowerLite 530 for SMART
- Epson PowerLite 580 for SMART

Order numbers

| | |
|--------|--|
| SB880E | 77" (195.6 cm) diagonal SMART Board interactive whiteboard. Includes a SMART Notebook software installation DVD. |
|--------|--|

Optional accessories See smarttech.com/accessories

smarttech.com/support
smarttech.com/contactsupport

© 2016 SMART Technologies ULC. All rights reserved. SMART Board, smarttech, the SMART logo and all SMART taglines are trademarks or registered trademarks of SMART Technologies ULC in the U.S. and/or other countries. All third-party product and company names may be trademarks of their respective owners. This product and/or use thereof is covered by one or more of the following U.S. patents: www.smarttech.com/patents. Contents are subject to change without notice. 03/2016.