



# Cisco UCS S3260 Storage Server

CISCO SYSTEMS  
170 WEST TASMAN DR.  
SAN JOSE, CA, 95134  
[WWW.CISCO.COM](http://WWW.CISCO.COM)

#### PUBLICATION HISTORY

REV B.6      MARCH 6, 2017

---

# CONTENTS

<b>OVERVIEW</b>	<b>3</b>
<b>DETAILED VIEWS</b>	<b>5</b>
Chassis Front View	5
Chassis Rear View	6
<b>BASE SERVER STANDARD CAPABILITIES and FEATURES</b>	<b>9</b>
<b>CONFIGURING the SERVER</b>	<b>12</b>
STEP 1 VERIFY SERVER SKU	13
STEP 2 SELECT SYSTEM I/O CONTROLLER (OPTIONAL)	14
STEP 3 SELECT TRANSCEIVERS OR SFP CABLES FOR SYSTEM I/O CONTROLLER (OPTIONAL)	15
STEP 4 SELECT SERVER NODE	17
C3X60 M3 Server Nodes with v2 CPUs	17
C3X60 M4 Server Node (with v4 CPUs)	21
STEP 5 SELECT I/O EXPANDER (OPTIONAL)	24
STEP 6 SELECT HARD DISK DRIVE (HDD) MULTIPACKS	25
STEP 7 SELECT HARD DISK DRIVES (HDDs) or SOLID STATE DRIVES (SSDs)	29
STEP 8 SELECT BOOT DRIVES	30
STEP 9 SELECT DISK EXPANSION TRAY AND DRIVES (OPTIONAL)	31
STEP 10 SELECT NIC MODE (OPTIONAL)	33
STEP 11 ORDER POWER SUPPLY	34
STEP 12 SELECT AC POWER CORD(s)	35
STEP 13 ORDER REVERSIBLE CABLE MANAGEMENT ARM (OPTIONAL)	38
STEP 14 ORDER OPTIONAL USB DRIVE	39
STEP 15 ORDER A TRUSTED PLATFORM MODULE (OPTIONAL)	40
STEP 16 ORDER A KVM CABLE (OPTIONAL)	41
STEP 17 SELECT OPERATING SYSTEM AND VALUE-ADDED SOFTWARE	42
STEP 18 SELECT OPERATING SYSTEM MEDIA KIT	44
STEP 19 SELECT SERVICE and SUPPORT LEVEL	45
<b>OPTIONAL STEP - ORDER RACK(s)</b>	<b>50</b>
<b>OPTIONAL STEP - ORDER PDU</b>	<b>51</b>
<b>SUPPLEMENTAL MATERIAL</b>	<b>52</b>
CHASSIS	52
CPUs and DIMMs	53
C3X60 M3 Server Node Physical Layout	53
C3X60 M4 Server Node Physical Layout	54
Memory Population Rules	55
Internal Drive Population Guidelines	56
Upgrade and Servicing-Related Parts	57
System I/O Controller Blanking Panel	58
RACKS	59
PDUs	61
<b>TECHNICAL SPECIFICATIONS</b>	<b>62</b>
Dimensions and Weight	62
Power Specifications	63
Environmental Specifications	64
Compliance Requirements	65

## OVERVIEW

The Cisco UCS S3260 Storage Server is a modular, storage server with dual M3 or M4 server nodes<sup>1</sup>, optimized for large datasets used in environments such as big data, cloud, object storage, and content delivery.

The Cisco UCS S3260 chassis is a modular architecture consisting of the following modules:

1. **Base Chassis:** contains eight redundant, hot-pluggable fans, and a rail kit.
2. **Server Node:** one or two C3X60 M3 or C3X60 M4 server nodes, each with two CPUs, 128, 256, or 512 GB of DIMM memory, and a pass-through controller or a RAID card with a 4 GB cache. The C3X60 M4 server node also supports one SSD.
3. **System I/O Controller (SIOC):** one System I/O Controller per node, each of which includes an integrated 1300-series virtual interface capability.
4. **Hard Drives:** Up to 56 top-loading Large Form Factor (LFF) HDDs of 4TB, 6TB, 8TB and 10TB capacities.
5. **Solid State Drives:** Optionally up to 28 SSDs of 400GB, 800 GB, 1.6TB, and 3.2 TB capacities.
6. **Solid-State Boot Drives:** up to two SSDs per C3X60 M3 or C3X60 M4 server node.
7. **Optional Drive Expansion Node:** Large Form Factor (LFF) 3.5-in. drives in a choice of capacities.
8. **I/O Expander:** provides two PCIe expansion slots.

The enterprise-class Cisco UCS S3260 storage server extends the capabilities of Cisco's Unified Computing System portfolio in a 4U form factor that delivers the best combination of high-availability performance, flexibility, and efficiency gains. See [Figure 1 on page 4](#).

### Notes

---

1. A C3X60 M3 Server Node is has Intel E5-2600 V2 CPUs and DDR-3 DIMMs. A C3X60 M4 Server Node has Intel E5-2600 v4 CPUs and DDR-4 DIMMs

Figure 1 Cisco UCS S3260 Storage Server

Front View



Rear View



# DETAILED VIEWS

## Chassis Front View

Figure 2 shows the Cisco UCS S3260 Storage Server.

Figure 2 Chassis Front View

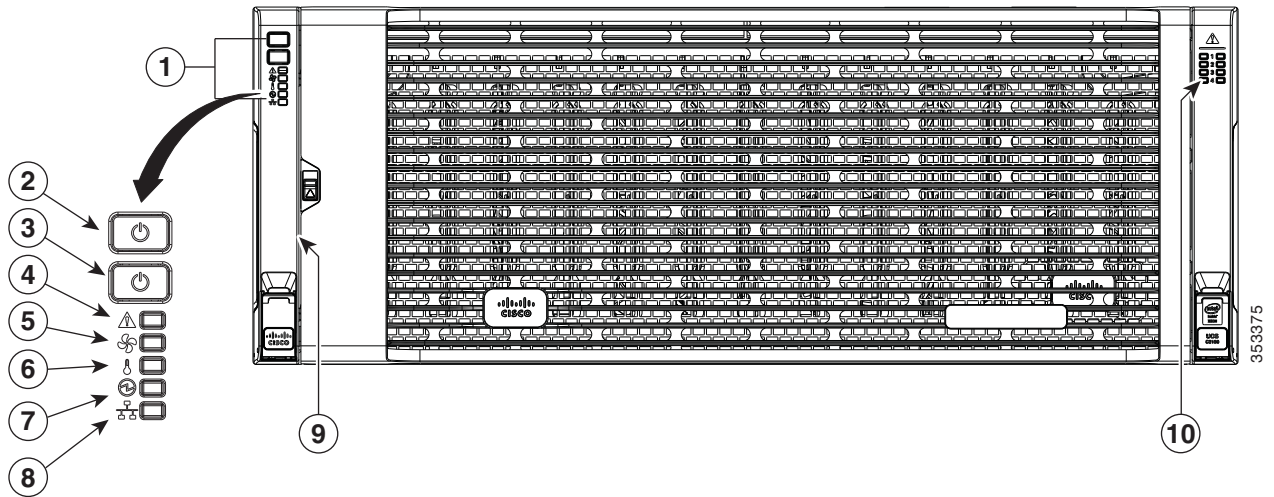

1	Operations panel	6	Temperature status LED
2	System power button/LED	7	Power supply status LED
3	System unit identification button/LED	8	Network link activity LED
4	System status LED	9	Pull-out asset tag (not visible under front bezel)
5	Fan status LED	10	Internal-drive status LEDs

## Chassis Rear View

Figure 3 and Figure 4 show the external features of the rear of the chassis with C3X60 M3 server nodes (v2 CPUs) installed.

Figure 3 Chassis Rear View (two C3X60 M3 server nodes installed)

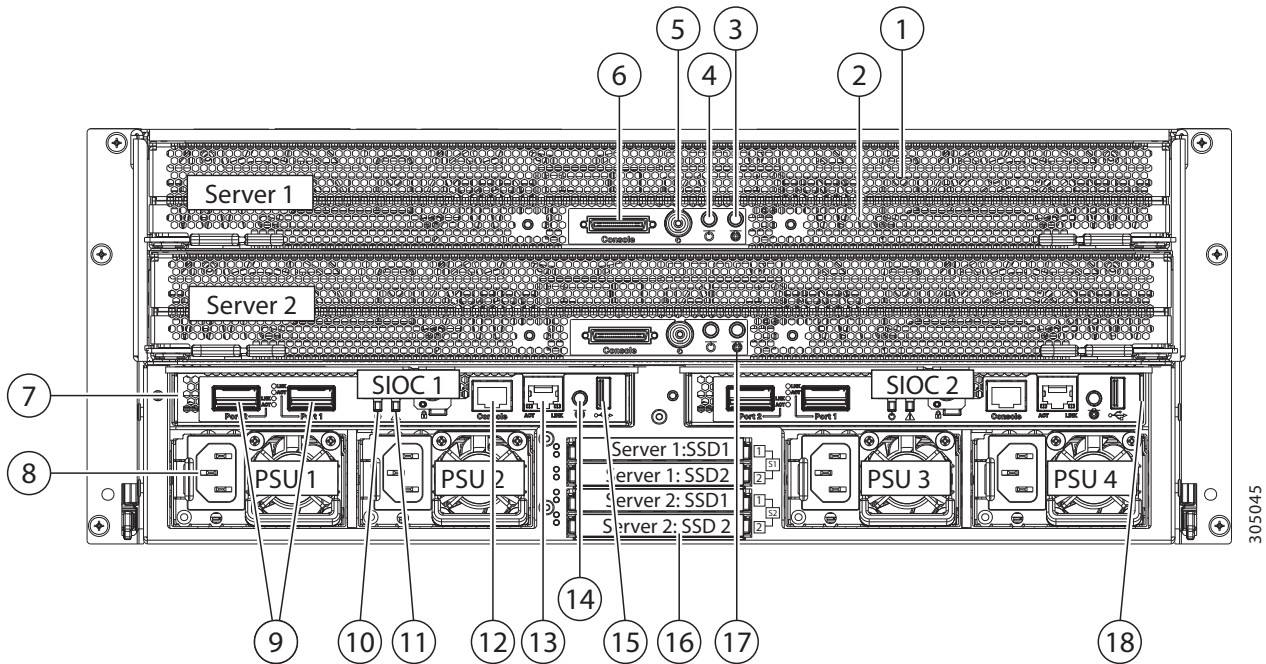

1	C3X60 M3 Server Node bay 1 If there is only one M3 server node, it must be in bay 1. The diagram shows an M3 server node installed in server bays 1 and 2 <sup>1</sup> .	10	SIOC power LED (one each SIOC)
2	Server node health LED (behind mesh, on board)	11	System status LED (one each SIOC)
3	Server node unit identification button/LED	12	Not used at this time
4	Server node Power button/LED	13	10/100/1000 dedicated management port (RJ-45 connector) (one each SIOC) This port has a link activity and a link speed LED.
5	Server node reset button (resets processor chipset in server node)	14	SIOC unit identification LED (one each SIOC)
6	KVM console connector <sup>2</sup> on server node Used with a KVM cable that provides two USB, one VGA, and one serial connector	15	USB 3.0 port (one each SIOC).

7	System I/O controller (SIOC) 1	16	Solid state drive (SSD) bays (up to four 2.5-inch SSDs)  SSDs 1 and 2 for server 2 require a second C3X60 M3 server node. Server node 1 can manage upper SSD bays 1 and 2; server node 2 can manage lower SSD bays 1 and 2. The drives are managed by means of the PCH and OS or SW RAID.
8	Power supplies (four, redundant as 2+2)	17	Drive expander module status LED (if module is present)
9	40-Gb QSFP+ ports (two on each SIOC) Each port has a link and an activity LED.	18	(Optional) SIOC 2  SIOC 2 is required if you have two C3X60 M3 server nodes.

Notes

1. If an optional disk expander is installed, it can be installed in server bay 2 only.
2. For more information on the KVM port, see [ORDER A KVM CABLE \(OPTIONAL\)](#), page 41.

Figure 4 Chassis Rear View (one C3X60 M3 server node installed and one drive expander module installed)

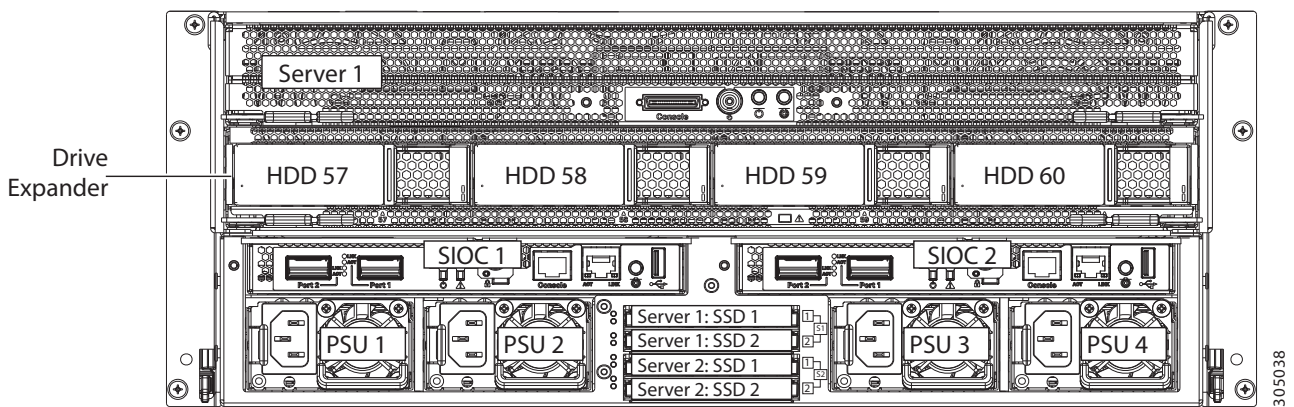
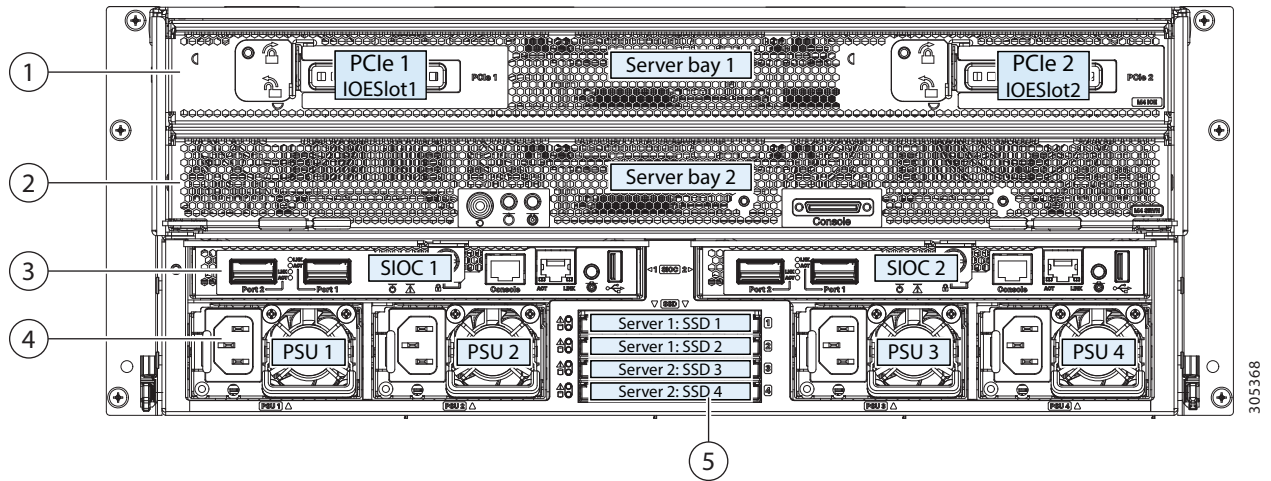

Figure 5 shows the external features of the rear of the chassis with a C3X60 M4 server node (v4 CPUs) and I/O expander installed.

Figure 5 Chassis Rear View (one C3X60 M4 server node installed and one I/O expander installed)



1	Server bay 1 <ul style="list-style-type: none"> <li>■ (Optional) I/O expander, as shown</li> <li>■ (Optional) C3X60 M4 server node</li> <li>■ (Optional) drive expansion module</li> </ul>	4	Power supplies (four, redundant as 2+2)
2	Server bay 2 <ul style="list-style-type: none"> <li>■ (Optional) C3X60 M4 server node, as shown</li> <li>■ (Optional) drive expansion module</li> </ul>	5	2.5-inch SAS/SATA SSDs (up to four)
3	System I/O controllers (SIOCs) (one or two)	—	—

## BASE SERVER STANDARD CAPABILITIES and FEATURES

*Table 1* lists the capabilities and features of the base server. Details about how to configure the server for a particular feature or capability (for example, number of processors, disk drives, or amount of memory) are provided in *CONFIGURING the SERVER, page 12*.

Table 1 Capabilities and Features

Capability/Feature	Description
Chassis	Four rack unit (4RU) chassis
Server Node	One or two server nodes plug into the back of the server. There are two types of server nodes: <ul style="list-style-type: none"> <li>■ C3X60 M3 server node (with v2 CPUs)</li> <li>■ C3X60 M4 server node (with v4 CPUs)</li> </ul> A C3X60 M3 server node contains two CPUs and a C3X60 M4 server node also contains two CPUs. Each node has up to 512 GB of DIMM memory and a RAID controller in pass-through mode or with up to 4 GB of RAID cache.
CPU	Intel Xeon E5-2600 v2 or v4 series processor family CPUs
System I/O Controller	The system can have one or two system I/O controllers (SIOCs). These provide rear-panel management and data connectivity. <ul style="list-style-type: none"> <li>■ Two SFP+ 40 Gb ports each SIOC</li> <li>■ One 10/100/1000 Ethernet dedicated management port on each SIOC</li> </ul>
IO Expander	An optional I/O expander can be attached to the top of a server node and occupy server bay 1 (upper bay). It provides two 8x PCIe expansion slots (compatible with C3X60 M4 server node only)
Chipset	Intel® C600 series chipset for v2 CPUs or C610 chipset for v4 CPUs
Memory	16 slots for registered ECC registered DIMMs (RDIMMs) or load-reduced DIMMs (LRDIMMs) per server node
Multi-bit Error Protection	This server supports multi-bit error protection.
Video	Integrated 2D graphics controller supporting up to 1600 x 1200 resolution
Interfaces	Rear panel <ul style="list-style-type: none"> <li>■ Two plug-in System I/O controllers, each with a dedicated 1 Gbps RJ45 Management port used for remote setup, a USB port, two 40-Gb QSFP+ ports and a console port for PPC. Each controller contains a built-in 1300-series virtual interface capability.</li> <li>■ One KVM console connector on the server node (supplies two USB 2.0 connectors, one VGA DB15 video connector, and one serial port (RS232) RJ45 connector).</li> </ul> Front panel <ul style="list-style-type: none"> <li>■ There are no interface ports on the front panel.</li> </ul>

Capability/Feature	Description
Power subsystem	<p>Four of the following hot-swappable power supplies:</p> <ul style="list-style-type: none"> <li>■ 1050 W (AC), or</li> <li>■ 1050 W (DC)</li> </ul>
UCS Manager	<p>Four power supplies are mandatory (redundant as 2+2).            With UCSM 3.1.2a, the Cisco UCS S3260 can be managed using the 6200 and 6300 Fabric Interconnects.</p>
Internal storage devices	<p>Top loading drives<sup>1</sup></p> <ul style="list-style-type: none"> <li>■ Up to 56 4 TB, 6 TB, 8 TB, or 10 TB 3.5” hard disk drives can be installed into top-accessible drive bays, which provide hot-pluggable access.</li> <li>■ Up to 28 400 GB, 800 GB, 1.6 TB, or 3.2 TB 2.5” solid-state disk drives<sup>2</sup> can be installed into top-accessible drive bays, which provide hot-pluggable access.</li> </ul> <p>Rear loading drives</p> <ul style="list-style-type: none"> <li>■ Up to four 4 TB, 6 TB, 8 TB, or 10 TB 3.5” drives can be installed into an optional disk expander module at the back of the chassis in server bay 2.</li> <li>■ Up to four SATA SSD drives located at the rear of the chassis for OS boot mirror (up to two per server node).</li> </ul> <p>NVMe drives</p> <ul style="list-style-type: none"> <li>■ One 2.5-inch NVMe SSD in the C3X60 M4 server node</li> </ul> <p>USB Storage</p> <ul style="list-style-type: none"> <li>■ The C3X60 M3 server node includes one internal USB 2.0 slot inside the server node.</li> </ul>
PCIe I/O	<p>The main chassis has no PCIe expansion slots; however, the optional I/O expander does contain two PCIe slots. Note that the optional I/O Expander is only available with the C3X60 M4 server node.</p>
Front Panel Integrated management processor	<ul style="list-style-type: none"> <li>■ A front panel controller provides status indications and control buttons</li> </ul> <p>Baseboard Management Controller (BMC) running Cisco Integrated Management Controller (CIMC) firmware.</p> <p>Depending on your CIMC settings, the CIMC can be accessed through the 1-GbE dedicated management port.</p>
Fans	<p>Chassis:</p> <ul style="list-style-type: none"> <li>■ Four hot-swappable dual fan modules that provide front-to-rear cooling (8 fans total)</li> <li>■ One fan in each power supply</li> </ul>

Capability/Feature	Description												
Storage controller	<p>Each Server Node module and optional I/O expander has a mezzanine connector. The C3X60 M3 server nodes (with v2 CPUs) support the Cisco UCS C3X60 12G SAS RAID Controller card in pass-through mode or with write cache and SuperCap backup, or the HBA pass-through controller (UCSC-C3X60-HBA). The C3X60 M4 server nodes (with v4 CPUs) and the optional I/O expander support the Cisco UCS C3X60 RAID controller with 4GB cache. Note that the drive connections are multipath.</p> <p>Access to the connector and card requires removing the server module or I/O expander and removing its top cover.</p> <p>The Cisco UCS C3X60 12G SAS RAID Controller card with RAID cache is available with an onboard Flash-Backed Write Cache (FBWC), as shown in the table below</p> <table border="1"> <thead> <tr> <th>RAID Card Version</th> <th>Supported RAID Levels</th> <th>Onboard FBWC</th> </tr> </thead> <tbody> <tr> <td>UCSC-C3X60-R1GB</td> <td>JBOD, RAID 0, 1, 5, 6, 10, 50, 60</td> <td>1 GB</td> </tr> <tr> <td>UCSC-C3X60-R4GB</td> <td>JBOD, RAID 0, 1, 5, 6, 10, 50, 60</td> <td>4 GB</td> </tr> <tr> <td>UCS-C3K-M4RAID</td> <td>JBOD, RAID 0, 1, 5, 6, 10, 50, 60</td> <td>4 GB</td> </tr> </tbody> </table> <p>The maximum number of drives that can be assigned to a single RAID group is 32.</p> <p>All versions of the RAID controller support up to 60 drives. Each server node can be assigned specific drive combinations by means of CIMC Management.</p> <p>The Cisco UCS C3X60 12G SAS HBA Controller is pass-through and both server nodes will see all the drives. Management of the drives will be at the OS Level with HBA Mode.</p> <p>Note that the C3X60 M3 server node (only) supports the UCSC-C3X60-HBA.</p>	RAID Card Version	Supported RAID Levels	Onboard FBWC	UCSC-C3X60-R1GB	JBOD, RAID 0, 1, 5, 6, 10, 50, 60	1 GB	UCSC-C3X60-R4GB	JBOD, RAID 0, 1, 5, 6, 10, 50, 60	4 GB	UCS-C3K-M4RAID	JBOD, RAID 0, 1, 5, 6, 10, 50, 60	4 GB
RAID Card Version	Supported RAID Levels	Onboard FBWC											
UCSC-C3X60-R1GB	JBOD, RAID 0, 1, 5, 6, 10, 50, 60	1 GB											
UCSC-C3X60-R4GB	JBOD, RAID 0, 1, 5, 6, 10, 50, 60	4 GB											
UCS-C3K-M4RAID	JBOD, RAID 0, 1, 5, 6, 10, 50, 60	4 GB											

Notes

1. All drives are hot swappable (no preconditioning of the component is required before removal while the system is powered on).
2. Drive carriers adapt the 2.5” SSD drives to the 3.5” drive bays in the top of the chassis.

## CONFIGURING the SERVER

Follow these steps to configure the Cisco UCS S3260 Storage Server:

- *STEP 1 VERIFY SERVER SKU, page 13*
- *STEP 2 SELECT SYSTEM I/O CONTROLLER (OPTIONAL), page 14*
- *STEP 3 SELECT TRANSCEIVERS OR SFP CABLES FOR SYSTEM I/O CONTROLLER (OPTIONAL), page 15*
- *STEP 4 SELECT SERVER NODE, page 17*
- *STEP 5 SELECT I/O EXPANDER (OPTIONAL), page 24*
- *STEP 6 SELECT HARD DISK DRIVE (HDD) MULTIPACKS, page 25*
- *STEP 8 SELECT BOOT DRIVES, page 30*
- *STEP 9 SELECT DISK EXPANSION TRAY AND DRIVES (OPTIONAL), page 31*
- *STEP 10 SELECT NIC MODE (OPTIONAL), page 33*
- *STEP 11 ORDER POWER SUPPLY, page 34*
- *STEP 12 SELECT AC POWER CORD(s), page 35*
- *STEP 13 ORDER REVERSIBLE CABLE MANAGEMENT ARM (OPTIONAL), page 38*
- *STEP 14 ORDER OPTIONAL USB DRIVE, page 39*
- *STEP 15 ORDER A TRUSTED PLATFORM MODULE (OPTIONAL), page 40*
- *STEP 16 ORDER A KVM CABLE (OPTIONAL), page 41*
- *STEP 17 SELECT OPERATING SYSTEM AND VALUE-ADDED SOFTWARE, page 42*
- *STEP 18 SELECT OPERATING SYSTEM MEDIA KIT, page 44*
- *STEP 19 SELECT SERVICE and SUPPORT LEVEL, page 45*
- *OPTIONAL STEP - ORDER RACK(s), page 50*
- *OPTIONAL STEP - ORDER PDU, page 51*

## STEP 1 VERIFY SERVER SKU

Select the base server product ID (PID) from [Table 2](#).

Table 2 PID of the Cisco UCS S3260 Base Server

Product ID (PID)	Description
UCSS-S3260	Cisco UCS S3260 Storage Server, one rail kit, and bezel.

The Cisco UCS S3260 Storage Server:

- Does not include internal storage drives, system I/O controller, power supplies, or server node (no CPU, memory, or RAID controller).



**NOTE:** Use the steps on the following pages to configure the server with the components that you want to include.

## STEP 2 SELECT SYSTEM I/O CONTROLLER (OPTIONAL)

Select system I/O controllers from [Table 3](#). Each system I/O controller contains a built-in 1300-series VIC with two 40 Gb QSFP ports.

Table 3 PID of the System I/O Module

Product ID (PID)	Description
UCSC-C3260-SIOC	Cisco UCS S3260 System IO Controller with 1300-series VIC included

### Approved Configurations

- Select one or two system I/O controllers.

### Caveats

- If you select two server nodes and two SIOCs, you have the following functionality:
  - The top server node works with the left SIOC (as viewed from the rear).
  - The bottom server node works with the right SIOC (as viewed from the rear).

### STEP 3 SELECT TRANSCEIVERS OR SFP CABLES FOR SYSTEM I/O CONTROLLER (OPTIONAL)



NOTE: All the components on this page are orderable as spares.

Select an appropriate system I/O controller optical transceiver or SFP cable from [Table 4](#).

Table 4 PIDs for SIOC Optical Transceivers and SFP Cables

Rate	Optical Transceiver and SFP Cable PIDs	Description
10 Gbps <sup>1</sup>	SFP-10G-SR	10GBASE-SR SFP optical transceiver
	SFP-H10GB-CU1M	10GBASE-CU SFP+ Cable 1 Meter
	SFP-H10GB-CU3M	10GBASE-CU SFP+ Cable 3 Meter
	SFP-H10GB-CU5M	10GBASE-CU SFP+ Cable 5 Meter
	SFP-H10GB-ACU7M	Active Twinax cable assembly, 7m
	SFP-H10GB-ACU10M	Active Twinax cable assembly, 10m
	CVR-QSFP-SFP10G	QSFP to SFP+ adapter (QSA)
	SFP-10G-LR	10GBASE-LR SFP Module (Requires CVR-QSFP-SFP10G)

Table 4 PIDs for SIOC Optical Transceivers and SFP Cables *(continued)*

Rate	Optical Transceiver and SFP Cable PIDs	Description
40 Gbps	QSFP-40G-SR-BD	QSFP40G bidirectional short-reach optical transceiver
	QSFP-40G-SR4	40GBASE-SR4 QSFP optical transceiver module with MPO connector
	QSFP-H40G-CU1M	40GBASE-CR4 Passive Copper Cable, 1m
	QSFP-H40G-CU3M	40GBASE-CR4 Passive Copper Cable, 3m
	QSFP-H40G-CU5M	40GBASE-CR4 Passive Copper Cable, 5m
	QSFP-H40G-ACU7M	40GBASE-CR4 Active Copper Cable, 7m
	QSFP-H40G-ACU10M	40GBASE-CR4 Active Copper Cable, 10m
	QSFP-4SFP10G-CU1M	QSFP to 4xSFP10G Passive Copper Splitter Cable, 1m
	QSFP-4SFP10G-CU3M	QSFP to 4xSFP10G Passive Copper Splitter Cable, 3m
	QSFP-4SFP10G-CU5M	QSFP to 4xSFP10G Passive Copper Splitter Cable, 5m
	QSFP-4X10G-AC7M	QSFP to 4xSFP10G Active Copper Splitter Cable, 7m
	QSFP-4X10G-AC10M	QSFP to 4xSFP10G Active Copper Splitter Cable, 10m
	QSFP-40G-LR4	QSFP 40GBASE-LR4 transceiver module, LC, 10km
	QSFP-4X10G-LR-S	4x10GBASE-LR transceiver module, SM MPO, 10KM
	QSFP-H40G-AOC1M	40-Gbps QSFP active optical cable, 1m
	QSFP-H40G-AOC2M	40-Gbps QSFP active optical cable, 2m
	QSFP-H40G-AOC3M	40-Gbps QSFP active optical cable, 3m
	QSFP-H40G-AOC5M	40-Gbps QSFP active optical cable, 5m
	QSFP-H40G-AOC7M	QSFP to QSFP active optical cables,7m
	QSFP-H40G-AOC10M	40-Gbps QSFP active optical cable, 10m
	QSFP-4X10G-AOC1M	QSFP to four SFP+ active optical breakout cables,1m
	QSFP-4X10G-AOC2M	QSFP to four SFP+ active optical breakout cables,2m
	QSFP-4X10G-AOC3M	QSFP to four SFP+ active optical breakout cables,3m
	QSFP-4X10G-AOC5M	QSFP to four SFP+ active optical breakout cables,5m
	QSFP-4X10G-AOC7M	QSFP to four SFP+ active optical breakout cables,7m
	QSFP-4X10G-AOC10M	QSFP to four SFP+ active optical breakout cables,10m

Notes

1. In order to use a 10 Gbps SFP transceiver or cable, you must first install a QSFP to SFP 10G adapter (PID CVR-QSFP-SFP10G) in the SIOC QSFP port.

## STEP 4 SELECT SERVER NODE

There are two types of server nodes:

- C3X60 M3 Server Nodes with one or two Intel Xeon E5-2600 v2 series processor family CPUs
- C3X60 M4 Server Nodes with two Intel Xeon E5-2600 v4 series processor family CPUs



NOTE: Do not mix C3X60 M3 and C3X60 M4 server nodes.

---



NOTE: The C3X60 M4 server node has a label “M4 SRVN” on the lower right hand corner of the server node. The C3X60 M3 server node has no such label.

---

### C3X60 M3 Server Nodes with v2 CPUs

The C3X60 M3 server nodes have the following features:

- CPUs
  - Two E52600 v2 series family processor CPUs per server node
  - Quick Path Interconnect (QPI) between the CPUs for high-performance transfers between processors and I/O nodes
- Memory DIMMs
  - 8 DIMMs per CPU
  - 4 DIMM channels
  - 2 DIMMs per channel (DPC)
  - ECC DDR3L registered DIMMs (RDIMMs) or load-reduced DIMMs (LRDIMMs), operating at 1866 MHz
- Storage Controller
  - One Cisco 12G SAS RAID controller (supports JBOD and RAID levels 0,1,5,6,10,50,60), with 1 GB or 4 GB flash-backed write cache.
  - One Cisco 12G SAS HBA controller for pass-through

Select one or two server node product IDs (PIDs) from [Table 5](#).

Table 5 PID of the Server Node

Product ID (PID)	Description
UCSC-C3X60-SVRN2	UCS C3X60 Complete Server Config 2 with CPU, Memory, JBOD, RAID Comes with the following:
UCS-CPU-E52620B	2 CPUs: 2.10 GHz E5-2620 v2/80W 6C/15MB Cache/DDR3 1600MHz
UCS-MR-1X162RZ-A	256 GB memory: 16 x 16GB DDR3-1866-MHz RDIMM/PC3-14900/dual rank/x4/1.5v
UCSC-C3X60-R4GB	1 RAID controller: UCS C3X60 12G SAS RAID Controller with 4GB cache
UCSC-C3X60-SVRN3	UCS C3X60 Complete Server Config 3 with CPU, Memory, JBOD, RAID Comes with the following:
UCS-CPU-E52660B	2 CPUs: 2.20 GHz E5-2660 v2/95W 10C/25MB Cache/DDR3 1866MHz
UCS-MR-1X162RZ-A	256 GB memory: 16 x 16GB DDR3-1866-MHz RDIMM/PC3-14900/dual rank/x4/1.5v
UCSC-C3X60-R4GB	1 RAID controller: UCS C3X60 12G SAS RAID Controller with 4GB cache
UCSC-C3X60-SVRN4	UCS C3X60 Complete Server Config 4 with CPU, Memory, JBOD, RAID Comes with the following:
UCS-CPU-E52695B	2 CPUs: 2.40 GHz E5-2695 v2/115W 12C/30MB Cache/DDR3 1866MHz
UCS-MR-1X162RZ-A	256 GB memory: 16 x 16GB DDR3-1866-MHz RDIMM/PC3-14900/dual rank/x4/1.5v
UCSC-C3X60-R4GB	1 RAID controller: UCS C3X60 12G SAS RAID Controller with 4GB cache
UCSC-C3X60-SVRN6	UCS C3X60 Complete Server Config 6 with CPU, Memory, HBA Comes with the following:
UCS-CPU-E52660B	2 CPUs: 2.20 GHz E5-2660 v2/95W 10C/25MB Cache/DDR3 1866MHz
UCS-MR-1X162RZ-A	128 GB memory: 8 x 16 GB DDR3-1866-MHz RDIMM/PC3-14900/dual rank/x4/1.5v
UCSC-C3X60-HBA	12G SAS pass-through controller
UCSC-C3X60-SVRN7	UCS C3X60 Complete Server Config 7 with CPU, Memory, HBA Comes with the following:
UCS-CPU-E52695B	2 CPUs: 2.40 GHz E5-2695 v2/115W 12C/30MB Cache/DDR3 1866MHz
UCS-MR-1X162RZ-A	256 GB memory: 16 x 16 GB DDR3-1866-MHz RDIMM/PC3-14900/dual rank/x4/1.5v
UCSC-C3X60-HBA	12G SAS pass-through controller

Table 5 PID of the Server Node (*continued*)

Product ID (PID)	Description
UCSC-C3X60-SVRN8	UCS C3X60 Complete Server Config 8 with CPU, Memory, HBA Comes with the following:
UCS-CPU-E52620B	2 CPUs: 2.10 GHz E5-2620 v2/80W 6C/15MB Cache/DDR3 1600MHz
UCS-MR-1X162RZ-A	256 GB memory: 16 x 16 GB DDR3-1866-MHz RDIMM/PC3-14900/dual rank/x4/1.5v
UCSC-C3X60-HBA	12G SAS pass-through controller

### Approved Configurations

- Select one or two server node PIDs.

### Caveats

- The following server nodes can be mixed:
  - First set: UCSC-C3X60-SVRN2, UCSC-C3X60-SVRN3, UCSC-C3X60-SVRN4, or
  - Second set: UCSC-C3X60-SVRN6, UCSC-C3X60-SVRN7, UCSC-C3X60-SVRN8



**NOTE:** None of the servers in the first set of server nodes above can be mixed with any server in the second set.

Further, server node UCSC-C3X60-SVRN1 cannot be mixed with any other server node. SVRN1 is recommended only to be used in a JBOD Mode and not for drives in other RAID Configurations. If an application demands a RAID Configuration, select the RAID Controller with a 4G RAID Cache (UCSC-C3X60-R4GB).

- If you select two server nodes, you cannot select a disk expansion tray and drives.
- If you select two server nodes, you have the following functionality:
  - The top server node works with the left SIOC (as viewed from the rear).
  - The bottom server node works with the right SIOC (as viewed from the rear).
- No DIMM configurations other than the factory default are supported.
- RAID levels supported by the 12 Gbps RAID controller (UCSC-C3X60-R4GB and UCSC-C3X60-R1GB) are as follows:
  - JBOD
  - RAID 0 uses striping to provide high data throughput, especially for large files in an environment that does not require fault tolerance.
  - RAID 1 uses mirroring so that data written to one drive is simultaneously written to another drive which is good for small databases or other applications that require small capacity, but complete data redundancy.

- RAID 5 uses disk striping and parity data across all drives (distributed parity) to provide high data throughput, especially for small random access.
- RAID 6 uses distributed parity, with two independent parity blocks per stripe, and disk striping. A RAID 6 virtual drive can survive the loss of two drives without losing data. A RAID 6 drive group, which requires a minimum of three drives, is similar to a RAID 5 drive group. Blocks of data and parity information are written across all drives. The parity information is used to recover the data if one or two drives fail in the drive group.
- A RAID 00 drive group is a spanned drive group that creates a striped set from a series of RAID 0 drive groups.
- RAID 10, a combination of RAID 0 and RAID 1, consists of striped data across mirrored spans. A RAID 10 drive group is a spanned drive group that creates a striped set from a series of mirrored drives. RAID 10 allows a maximum of eight spans. You must use an even number of drives in each RAID virtual drive in the span. The RAID 1 virtual drives must have the same stripe size. RAID 10 provides high data throughput and complete data redundancy but uses a larger number of spans.
- RAID 50, a combination of RAID 0 and RAID 5, uses distributed parity and disk striping. A RAID 50 drive group is a spanned drive group in which data is striped across multiple RAID 5 drive groups. RAID 50 works best with data that requires high reliability, high request rates, high data transfers, and medium-to-large capacity.
- RAID 60, a combination of RAID 0 and RAID 6, uses distributed parity, with two independent parity blocks per stripe in each RAID set, and disk striping. A RAID 60 virtual drive can survive the loss of two drives in each of the RAID 6 sets without losing data. It works best with data that requires high reliability, high request rates, high data transfers, and medium-to-large capacity.

## C3X60 M4 Server Node (with v4 CPUs)

This server node is configurable. The base PID of the C3X60 M4 server node is shown in [Table 6](#).

Table 6 UCS C3X60 M4 Server Node Base PID

Product ID (PID)	Description
UCSC-C3K-M4SRB	UCS C3X60 M4 Server Node for Intel E5-2600 v4

Use the following tables to choose options for the C3X60 M4 server node.

- Choose two CPUs from [Table 7](#).

Table 7 CPUs

Product ID (PID)	Description
UCS-CPU-E52695E	2.10 GHz E5-2695 v4/120W 18C/45MB Cache/DDR4 2400MHz
UCS-CPU-E52680E	2.40 GHz E5-2680 v4/120W 14C/35MB Cache/DDR4 2400MHz
UCS-CPU-E52650E	2.20 GHz E5-2650 v4/105W 12C/30MB Cache/DDR4 2400MHz
UCS-CPU-E52620E	2.10 GHz E5-2620 v4/85W 8C/20MB Cache/DDR4 2133MHz
UCS-CPU-E52640E	2.40 GHz E5-2640 v4/90W 10C/25MB Cache/DDR4 2133 MHz

- Choose 4 or 8 DIMMs per CPU from [Table 8](#).

Table 8 DIMMs

Product ID (PID)	Description
UCS-MR-1X322RV-A	32GB DDR4-2400-MHz RDIMM/PC4-19200/dual rank/x4/1.2v
UCS-MR-1X161RV-A	16GB DDR4-2400-MHz RDIMM/PC4-19200/single rank/x4/1.2v

- Choose a storage controller from [Table 9](#).

Table 9 Storage Controller

Product ID (PID)	Description
UCS-C3K-M4RAID	Cisco UCS C3X60 RAID Controller M4 Server w 4G RAID Cache



**NOTE:** The Cisco UCS C3X60 RAID Controller M4 Server supports JBOD and RAID levels 0,1,5,6,10,50, 60), with 4 GB flash-backed write cache

- Choose an optional Trusted Platform Module (TPM) from [Table 10](#).

Table 10 TPM

Product ID (PID)	Description
UCSX-TPM2-002	Trusted Platform Module 2.0 for UCS servers

- Choose one optional storage drive from [Table 11](#).

Table 11 Storage Drive

Product ID (PID)	Description
UCSC-C3K-NV8	Cisco UCS C3X60 800G NVMe SSD for M4 Server Blade
UCSC-C3K-NV16	Cisco UCS C3X60 1.6TB NVMe SSD for M4 Server Blade

### Approved Configurations

- Select one of the following:
  - Single C3X60 M4 server node in server node bay 1 with CIMC 2.0(13), or
  - Two C3X60 M4 server nodes in server node bay 1 and bay 2, or
  - Single C3X60 M4 server node in server node bay 1 (upper bay) and drive expansion module containing 4 x 3.5” drives in server node bay 2 (lower bay), or
  - Single C3X60 M4 server node in server node bay 2 (lower bay) and I/O expander in server node bay 1 (upper bay) - in this case, the active SIOC is SIOC-2, not SIOC-1.

### Caveats

- The UCSC-C3X60-SVRN1 through UCSC-C3X60-SVRN8 server nodes cannot be mixed with the UCSC-C3K-M4SRB server nodes
- If you select two server nodes, you cannot select a disk expansion tray and drives or an I/O expander.
- If you select two server nodes, you have the following functionality:
  - The top server node works with the left SIOC (as viewed from the rear).
  - The bottom server node works with the right SIOC (as viewed from the rear).

- RAID levels supported by the 12 Gbps RAID controller (UCS-C3K-M4RAID) are as follows: JBOD
  - RAID 0 uses striping to provide high data throughput, especially for large files in an environment that does not require fault tolerance.
  - RAID 1 uses mirroring so that data written to one drive is simultaneously written to another drive which is good for small databases or other applications that require small capacity, but complete data redundancy.
  - RAID 5 uses disk striping and parity data across all drives (distributed parity) to provide high data throughput, especially for small random access.
  - RAID 6 uses distributed parity, with two independent parity blocks per stripe, and disk striping. A RAID 6 virtual drive can survive the loss of two drives without losing data. A RAID 6 drive group, which requires a minimum of three drives, is similar to a RAID 5 drive group. Blocks of data and parity information are written across all drives. The parity information is used to recover the data if one or two drives fail in the drive group.
  - A RAID 00 drive group is a spanned drive group that creates a striped set from a series of RAID 0 drive groups.
  - RAID 10, a combination of RAID 0 and RAID 1, consists of striped data across mirrored spans. A RAID 10 drive group is a spanned drive group that creates a striped set from a series of mirrored drives. RAID 10 allows a maximum of eight spans. You must use an even number of drives in each RAID virtual drive in the span. The RAID 1 virtual drives must have the same stripe size. RAID 10 provides high data throughput and complete data redundancy but uses a larger number of spans.
  - RAID 50, a combination of RAID 0 and RAID 5, uses distributed parity and disk striping. A RAID 50 drive group is a spanned drive group in which data is striped across multiple RAID 5 drive groups. RAID 50 works best with data that requires high reliability, high request rates, high data transfers, and medium-to-large capacity.
  - RAID 60, a combination of RAID 0 and RAID 6, uses distributed parity, with two independent parity blocks per stripe in each RAID set, and disk striping. A RAID 60 virtual drive can survive the loss of two drives in each of the RAID 6 sets without losing data. It works best with data that requires high reliability, high request rates, high data transfers, and medium-to-large capacity.

## STEP 5 SELECT I/O EXPANDER (OPTIONAL)

Select the optional I/O expander product ID (PID) from [Table 12](#).



NOTE: An I/O expander can be replaced in the field, but cannot be added to upgrade an existing C3X60 M4 server node in the field.



NOTE: The I/O Expander has 2 x8 PCIe half-height half-width slots

Table 12 PID of the I/O Expander

Product ID (PID)	Description
UCSC-C3K-M4IO	Cisco UCS C3X60 I/O Expander for M4 C3X60 Server Blade

Select one or two PCIe modules for the I/O expander from [Table 13](#).

Table 13 PIDs of the PCIe Modules

Product ID (PID)	Description
N2XX-AIPCI01	Intel X520 Dual Port 10Gb SFP+ Adapter
UCSC-PCIE-IRJ45	Intel i350 Quad Port 1Gb Adapter
UCSC-F-FIO-1000PS	UCS 1000GB Fusion ioMemory3 PX Performance line for Rack M4
UCSC-F-S32002	UCS Rack PCIe Storage 3200GB SanDisk SX350 Medium Endurance
UCSC-PCIE-Q2672	Qlogic QLE2672-CSC, 16Gb Fibre Channel HBA with SR Optics
N2XX-AQPCI05	Qlogic QLE2562 Dual Port 8Gb Fibre Channel HBA
UCSC-PCIE-E16002	Emulex LPe16002-M6, 16Gb Fibre Channel HBA with SR Optics

## STEP 6 SELECT HARD DISK DRIVE (HDD) MULTIPACKS

Select drive multipacks from [Table 14](#). The drives in each multipack mount into drive trays at the top of the server.



NOTE: A minimum of 14 drives must be installed in the Cisco UCS S3260 chassis.

Table 14 Available Disk Multipacks

Product ID (PID)	PID Description	Drive Type	Capacity (each)
UCS-S3260-14HD4	UCS C3X60 1 row of 4 TB NL-SAS drives (14 total) 56 TB raw Includes 14 of the following: UCSC-C3K-HD4TB UCS C3000 4TB NL-SAS 7200 RPM 12Gb HDD w Carrier- Top Load	SAS-3	4 TB 512n
UCS-S3260-28HD4	UCS C3X60 2 rows of 4 TB NL-SAS drives (28 total) 112 TB raw Includes 28 of the following: UCSC-C3K-HD4TB UCS C3000 4TB NL-SAS 7200 RPM 12Gb HDD w Carrier- Top Load	SAS-3	4 TB 512n
UCS-S3260-42HD4	UCS C3X60 3 rows of 4 TB NL-SAS drives (42 total) 184 TB raw includes 42 of the following: UCSC-C3K-HD4TB UCS C3000 4TB NL-SAS 7200 RPM 12Gb HDD w Carrier- Top Load	SAS-3	4 TB 512n
UCS-S3260-56HD4	UCS C3X60 4 rows of 4 TB NL-SAS drives (56 total) 240 TB raw includes 56 of the following: UCSC-C3K-HD4TB UCS C3000 4TB NL-SAS 7200 RPM 12Gb HDD w Carrier- Top Load	SAS-3	4 TB 512n
UCS-C3K-14HD6E	UCS C3X60 1 row of 6TB 512e NL-SAS drives (14 total) 84 TB Includes 14 of the following: UCS-C3K-6TEM Cisco UCS C3000 6TB (512e) Top Load	SAS-3	6 TB 512e
UCS-C3K-28HD6E	UCS C3X60 2 rows of 6TB 512e NL-SAS drives (28 total) 168 TB Includes 14 of the following: UCS-C3K-6TEM Cisco UCS C3000 6TB (512e) Top Load	SAS-3	6 TB 512e
UCS-C3K-42HD6E	UCS C3X60 3 rows of 6TB 512e NL-SAS drives (42 total) 252 TB Includes 42 of the following: UCS-C3K-6TEM Cisco UCS C3000 6TB (512e) Top Load	SAS-3	6 TB 512e
UCS-C3K-56HD6E	UCS C3X60 4 rows of 6TB 512e NL-SAS drives (56 total) 336 TB Includes 14 of the following: UCS-C3K-6TEM Cisco UCS C3000 6TB (512e) Top Load	SAS-3	6 TB 512e

Table 14 Available Disk Multipacks (*continued*)

Product ID (PID)	PID Description	Drive Type	Capacity (each)
UCSC-C3X60-14HD6	UCS C3X60 1 row of 6 TB NL-SAS drives (14 total) 84 TB raw Includes 14 of the following: UCSC-C3X60-HD6TB UCS C3X60 6TB 12Gbps NL-SAS 7200RPM HARD DISK DRIVE including C3X60 HDD carrier (Top-load)	SAS-3	6 TB 4Kn
UCSC-C3X60-28HD6	UCS C3X60 2 rows of 6 TB NL-SAS drives (28 total) 168 TB raw Includes 28 of the following: UCSC-C3X60-HD6TB UCS C3X60 6TB 12Gbps NL-SAS 7200RPM HARD DISK DRIVE including C3X60 HDD carrier (Top-load)	SAS-3	6 TB 4Kn
UCSC-C3X60-42HD6	UCS C3X60 3 rows of 6 TB NL-SAS drives (42 total) 252 TB raw includes 42 of the following: UCSC-C3X60-HD6TB UCS C3X60 6TB 12Gbps NL-SAS 7200RPM HARD DISK DRIVE including C3X60 HDD carrier (Top-load)	SAS-3	6 TB 4Kn
UCSC-C3X60-56HD6	UCS C3X60 4 rows of 6 TB NL-SAS drives (56 total) 336 TB raw includes 56 of the following: UCSC-C3X60-HD6TB UCS C3X60 6TB 12Gbps NL-SAS 7200RPM HARD DISK DRIVE including C3X60 HDD carrier (Top-load)	SAS-3	6 TB 4Kn
UCSC-C3X60-14HD8	UCS C3X60 1 row of 8 TB NL-SAS drives (14 total) 112 TB raw Includes 14 of the following: UCSC-C3X60-HD8TB UCS C3X60 8TB NL-SAS 7.2K Helium HDD with HDD Carrier (Top load)	SAS-3	8 TB 4Kn
UCSC-C3X60-28HD8	UCS C3X60 2 rows of 8 TB NL-SAS drives (28 total) 224 TB raw Includes 28 of the following: UCSC-C3X60-HD8TB UCS C3X60 8TB NL-SAS 7.2K Helium HDD with HDD Carrier (Top load)	SAS-3	8 TB 4Kn
UCSC-C3X60-42HD8	UCS C3X60 3 rows of 8 TB NL-SAS drives (42 total) 336 TB raw Includes 42 of the following: UCSC-C3X60-HD8TB UCS C3X60 8TB NL-SAS 7.2K Helium HDD with HDD Carrier (Top load)	SAS-3	8 TB 4Kn
UCSC-C3X60-56HD8	UCS C3X60 4 rows of 8 TB NL-SAS drives (56 total) 448 TB raw Includes 56 of the following: UCSC-C3X60-HD8TB UCS C3X60 8TB NL-SAS 7.2K Helium HDD with HDD Carrier (Top load)	SAS-3	8 TB 4Kn

Table 14 Available Disk Multipacks (*continued*)

Product ID (PID)	PID Description	Drive Type	Capacity (each)
UCS-C3K-14HD10E	UCS C3X60 1 row of 10 TB 512e NL-SAS drives (14 total) 140 TB Includes 14 of the following: UCS-C3K-10TEM Cisco UCS C3000 10TB (512e) Top Load	SAS-3	10 TB 512e
UCS-C3K-28HD10E	UCS C3X60 2 rows of 10 TB 512e NL-SAS drives (14 total) 280 TB Includes 28 of the following: UCS-C3K-10TEM Cisco UCS C3000 10TB (512e) Top Load	SAS-3	10 TB 512e
UCS-C3K-42HD10E	UCS C3X60 3 rows of 10 TB 512e NL-SAS drives (14 total) 420 TB Includes 42 of the following: UCS-C3K-10TEM Cisco UCS C3000 10TB (512e) Top Load	SAS-3	10 TB 512e
UCS-C3K-56HD10E	UCS C3X60 4 rows of 10 TB 512e NL-SAS drives (56 total) 560 TB Includes 42 of the following: UCS-C3K-10TEM Cisco UCS C3000 10TB (512e) Top Load	SAS-3	10 TB 512e
UCS-C3K-14HD10	UCS C3X60 1 row of 10 TB NL-SAS drives (14 total) 140 TB raw Includes 14 of the following: UCSC-C3X60-10TB UCS C3X60 10TB NL-SAS 7.2K Helium HDD with HDD Carrier (Top load)	SAS-3	10 TB 4Kn
UCS-C3K-28HD10	UCS C3X60 2 rows of 10 TB NL-SAS drives (28 total) 280 TB raw Includes 28 of the following: UCSC-C3X60-10TB UCS C3X60 10TB NL-SAS 7.2K Helium HDD with HDD Carrier (Top load)	SAS-3	10 TB 4Kn
UCS-C3K-42HD10	UCS C3X60 3 rows of 10 TB NL-SAS drives (42 total) 420 TB raw Includes 42 of the following: UCSC-C3X60-10TB UCS C3X60 10TB NL-SAS 7.2K Helium HDD with HDD Carrier (Top load)	SAS-3	10 TB 4Kn
UCS-C3K-56HD10	UCS C3X60 4 rows of 10 TB NL-SAS drives (56 total) 560 TB raw Includes 56 of the following: UCSC-C3X60-10TB UCS C3X60 10TB NL-SAS 7.2K Helium HDD with HDD Carrier (Top load)	SAS-3	10 TB 4Kn

### Approved Configurations

---

- The UCS-S3260-14HD4, UCS-S3260-28HD4, UCS-S3260-42HD4, and UCS-S3260-42HD4 multipacks can be selected along with HDDs and SSDs from [Table 15 on page 29](#).
- The UCSC-C3X60-14HD6, UCSC-C3X60-28HD6, and UCSC-C3X60-42HD6 multipacks can be selected along with HDDs and SSDs from [Table 15 on page 29](#).
- The UCSC-C3X60-56HD6 multipack cannot be selected with any other multipack.
- The UCSC-C3X60-14HD8, UCSC-C3X60-28HD8, and UCSC-C3X60-42HD8 multipacks can be selected along with HDDs and SSDs from [Table 15 on page 29](#).
- The UCSC-C3X60-56HD8 multipack cannot be selected with any other multipack.
- The UCS-C3K-14HD10, UCS-C3K-28HD10, and UCS-C3K-42HD10 multipacks can be selected along with HDDs and SSDs from [Table 15 on page 29](#).
- The UCS-C3K-56HD10 multipack cannot be selected with any other multipack.
- You cannot mix multipacks that have different drive capacities (4, 6, 8, or 10 TB).
- Populate drive bays according to [Internal Drive Population Guidelines, page 56](#).

### Caveats

---

- Because the 6 TB, 8 TB, and 10 TB drives have 4096-byte sectors, VMware ESXi does not support this capability and therefore will not work with 6 TB, 8 TB, or 10 TB drives.
- 4Kn and 512e drives are not supported by VMware. VMware 6.5 will eventually support 512e drives.

## STEP 7 SELECT HARD DISK DRIVES (HDDs) or SOLID STATE DRIVES (SSDs)

Select additional drives as desired from [Table 15](#). The drives mount into drive trays at the top of the server. The drives can be added to the chassis in addition to the multipacks already selected in [STEP 7 SELECT HARD DISK DRIVES \(HDDs\) or SOLID STATE DRIVES \(SSDs\), page 29](#).

Table 15 Available Additional HDDs and SSDs

Product ID (PID)	PID Description	Drive Type	Capacity (each)
<b>HDDs</b>			
UCSC-C3X60-10TB	UCSC C3X60 10 TB 4Kn for Top-Load	SAS-3	10 TB 4Kn
UCS-C3K-10TEM	Cisco UCS C3000 10TB (512e) Top Load	SAS-3	10 TB 512e
UCSC-C3X60-HD8TB	UCSC 3X60 8 TB NL-SAS 7.2KHelium HDD with HDD Carrier	SAS-3	8 TB
UCS-C3K-6TEM	Cisco UCS C3000 6TB (512e) Top Load	SAS-3	6 TB 512e
UCSC-C3X60-HD6TB	UCS C3X60 6 TB 12Gbps NL-SAS 7200RPM HDD with HDD carrier	SAS-3	6TB
UCS-C3K-HD4TB	UCS C3000 4 TB NL-SAS 7200 RPM 12Gb HDD w Carrier- Top Load	SAS-3	4 TB
<b>SSDs</b>			
<b>Enterprise Performance 3X Read</b>			
UCS-C3K-3XTSSD32	Cisco UCS C3000 Top Load 3X 3.2 TB SSD	SAS-3	3.2 TB
UCS-C3K-3XTSSD16	Cisco UCS C3000 Top Load 3X 1.6 TB SSD	SAS-3	1.6 TB
UCS-C3K-3XTSSD4	Cisco UCS C3000 Top Load 3X 400 GB SSD	SAS-3	400 GB
UCS-C3K-3XTSSD8	Cisco UCS C3000 Top Load 3X 800 GB SSD	SAS-3	800 GB
<b>Enterprise Performance 10X Read</b>			
UCS-C3X60-12G2160	UCSC C3X60 1.6 TB 12Gbps SSD (Gen 2)	SAS-3	1.6 TB
UCS-C3X60-12G280	UCSC C3X60 800 GB 12Gbps SSD (Gen 2)	SAS-3	800 GB
UCS-C3X60-12G240	UCSC C3X60 400 GB 12Gbps SSD (Gen 2)	SAS-3	400 GB

### Approved Configurations

- If you selected a 14-drive multipack (one row of drives), or a 28-drive multipack (two rows of drives) from [Table 14](#), you can select a maximum of 28 HDDs or SSDs from [Table 15](#).
- If you selected a 42-drive multipack (one row of drives) [Table 14](#), you can select a maximum of 14 HDDs or SSDs from [Table 15](#).
- A minimum of 14 drives must be selected before individual drives or SSDs can be selected.
- Drive capacities cannot be mixed.

## STEP 8 SELECT BOOT DRIVES

Select one or two boot drives per server node from [Table 17](#).

Table 16 Boot Drives

Product ID (PID)	PID Description	Drive Type	Capacity (each)
UCS-C3X60-G2SD12	UCSC C3X60 120 GB Boot SSD (Gen 2)	SATA	120 GB
UCS-C3X60-G2SD48	UCSC C3X60 480 GB Boot SSD (Gen 2)	SATA	480 GB
UCS-C3X60-G2SD160	UCSC C3X60 1.6 TB Boot SSD (Gen 2)	SATA	1.6 TB

### Approved Configurations

- Select one or two boot drives for server node one or one or two boot drives for server node two.
- You must select at least one boot drive.
- Do not mix boot drive capacities



**NOTE:** With C3X60 M4 server nodes and CIMC 2.0(13), the rear panel boot SSDs are controlled only by a hardware RAID card in the corresponding server node. For C3X60 M3 and pre 2.0(13), software RAID and AHCI control the boot SSDs.

## STEP 9 SELECT DISK EXPANSION TRAY AND DRIVES (OPTIONAL)

Select the optional disk expansion tray from [Table 17](#). This selection adds an extra four 4, 6, 8, or 10 TB drives that mount at the rear of the chassis.

Table 17 Disk Expansion Tray and Drives

Product ID (PID)	PID Description	Drive Type	Capacity (each)
UCS-S3260-EX16T	Cisco UCS C3X60 Expander with 4x 4 TB 7200 RPM NL-SAS Drives Includes the following: UCS-C3K-HD4TBRR UCS C3000 4TB NL-SAS 7200 RPM 12Gb HDD w Carrier (rear load)	SAS	4 TB
UCS-C3K-EX24TE	UCS C3X60 Expander 4x 6 TB 512e NL-SAS drives 24 TB Includes the following: UCS-C3K-6TEM Cisco UCS C3000 6TB (512e) (rear load)	SAS	6 TB 512e
UCSC-C3X60-EX24T	UCS UCS C3X60 Expander with 4x 6 TB 12 Gbps 7200RPM NL-SAS Drives Includes the following: UCSC-C3X60-6TBRR 6 TB 12 Gbps NL-SAS 7200 RPM 3.5 inch HDD including C3X60 HDD carrier (rear load)	SAS	6 TB
UCSC-C3X60-EX32T	UCS UCS C3X60 Expander with 4 x 8TB 12 Gbps 7200RPM NL-SAS Drives Includes the following: UCSC-C3X60-8TBRR 8 TB 12 Gbps NL-SAS 7200 RPM 3.5 inch Helium HDD including C3X60 HDD carrier (rear load)	SAS-3	8 TB 4Kn
UCS-C3K-EX40TE	UCS C3X60 Expander 4x 10 TB 512e NL-SAS drives 40TB Includes the following: UCS-C3K-10TEM Cisco UCS C3000 10TB (512e) (rear load)	SAS-3	10 TB 512e
UCSC-C3K-EX40T	UCS UCS C3X60 Expander with 4 x 10TB 12 Gbps 7200RPM NL-SAS Drives Includes the following: UCSC-C3X60-10TBRR 10 TB 12 Gbps NL-SAS 7200 RPM 3.5 inch Helium HDD including C3X60 HDD carrier (rear load)	SAS-3	10 TB 4Kn

### Approved Configurations

- Select only a disk expansion tray with the four drives included.

- 6 TB, 8 TB, and 10 TB drives cannot be mixed with 4 TB drives

#### Caveats

---

- If you configure two server nodes, you cannot configure a disk expansion tray with drives.

## STEP 10 SELECT NIC MODE (OPTIONAL)

By default, the Cisco UCS S3260 server NIC mode is configured to be Shared LOM Extended, which means that the CIMC can be accessed through the 40Gb SFP ports.

To change the default NIC mode to Dedicated, select the UCSC-DLOM-01 PID shown in *Table 18*. In Dedicated NIC mode, the CIMC can be accessed only through the dedicated management port. See *Chassis Rear View (two C3X60 M3 server nodes installed)*, *page 6* for the location of the management port.

For more details on all the NIC mode settings, see

[http://www.cisco.com/c/en/us/td/docs/unified\\_computing/ucs/c/sw/gui/config/guide/2-0/b\\_Cisco\\_UCS\\_C-series\\_GUI\\_Configuration\\_Guide\\_201.pdf](http://www.cisco.com/c/en/us/td/docs/unified_computing/ucs/c/sw/gui/config/guide/2-0/b_Cisco_UCS_C-series_GUI_Configuration_Guide_201.pdf)

Table 18 Dedicated NIC Mode Ordering Information

Product ID (PID)	PID Description
UCSC-DLOM-01	Dedicated Mode BIOS setting for C-Series Servers

## STEP 11 ORDER POWER SUPPLY

The Cisco UCS S3260 accommodates four power supplies. Four power supplies are mandatory. Use [Table 19](#) to order the power supplies.

Table 19 Power Supply PID

Product ID (PID)	PID Description
UCSC-PSU1-1050W	UCS C3X60 1050W Power Supply Unit
UCSC-PSUV2-1050DC	1050W V2 -48 VDC Power Supply for C220M4/S3260



NOTE: All power supplies must be identical.

---

## STEP 12 SELECT AC POWER CORD(S)

Using [Table 20](#), select the appropriate AC power cords. You can select a minimum of no power cords and a maximum of two. If you select the option R2XX-DMYMPWRCORD, no power cord is shipped with the server.

Table 20 Available Power Cords

Product ID (PID)	PID Description	Images
R2XX-DMYMPWRCORD	No power cord (dummy PID to allow for a no power cord option)	Not applicable
CAB-N5K6A-NA	N5000 AC Power Cable, 6A, 250V, North America, 2.5m	
CAB-AC-L620-C13	AC Power Cord, NEMA L6-20 - C13, 2M/6.5ft	
CAB-C13-CBN	Cabinet Jumper Power Cord, 250 VAC 10A, C14-C13 Connectors	
CAB-C13-C14-2M	CABASY,WIRE,JUMPER CORD, PWR, 2 Meter, C13/C14,10A/250V	
CAB-C13-C14-AC	Power cord, C13 to C14 (recessed receptacle), 10A	

Table 20 Available Power Cords

Product ID (PID)	PID Description	Images
CAB-250V-10A-AR	N5000 AC Power Cable, 10A, 250V, Argentina, 2.5m	
CAB-9K10A-AU	N5000 AC Power Cable, 10A, 250V, Australia, 2.5m	
CAB-250V-10A-CN	N5000 AC Power Cable, 10A, 250V, China, 2.5m	
CAB-250V-10A-CN	AC Power Cord - 250V, 10A - PRC	
CAB-9K10A-EU	N5000 AC Power Cable, 10A, 250V, Europe, 2.5m	
CAB-250V-10A-ID	N5000 AC Power Cable, 10A, 250V, India, 2.5m	
CAB-250V-10A-IS	N5000 AC Power Cable, 10A, 250V, Israel, 2.5m	

Table 20 Available Power Cords

Product ID (PID)	PID Description	Images
CAB-9K10A-IT	N5000 AC Power Cable, 10A, 250V, Italy, 2.5m	<p>Plug: 1/3G (CEI 23-16)</p> <p>Cordset rating: 10 A, 250 V Length: 8 ft 2 in (2.5 m)</p> <p>Connector: C15M (EN60320/C15)</p>
CAB-9K10A-SW	N5000 AC Power Cable, 10A, 250V, Switzerland, 2.5m	<p>Plug: MP232-R</p> <p>Cordset rating: 10 A, 250 V Length: 8 ft 2 in (2.5 m)</p> <p>Connector: IEC 60320 C15</p>
CAB-9K10A-UK	N5000 AC Power Cable, 10A, 250V, United Kingdom, 2.5m	<p>Cordset rating: 10 A, 250 V/500 V MAX Length: 2500mm</p> <p>Plug: EL 210 (BS 1363A) 13 AMP fuse</p> <p>Connector: EL 701 C (EN 60320/C15)</p>
CAB-250V-10A-BR	Power Cord - 250V, 10A - Brazil	<p>2,133.6 ± 25</p>

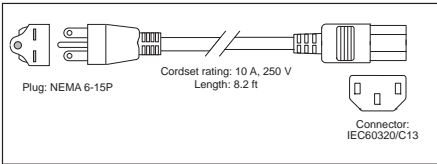
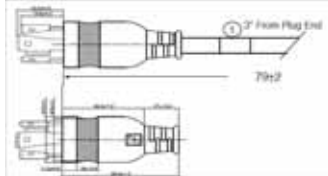
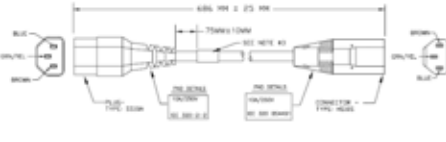
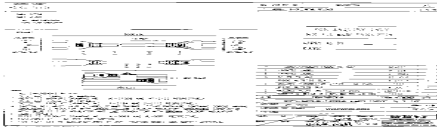
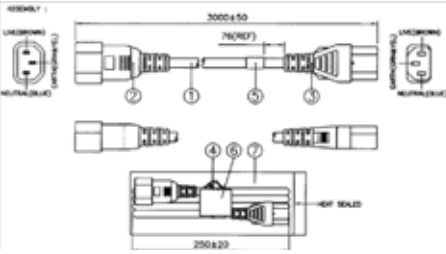
## STEP 13 ORDER REVERSIBLE CABLE MANAGEMENT ARM (OPTIONAL)

The reversible cable management arm mounts on either the right or left slide rails at the rear of the server and is used for cable management. Use [Table 21](#) to order a cable management arm.

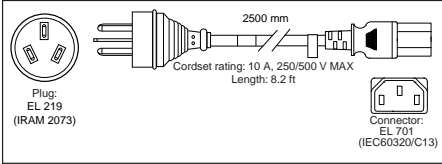
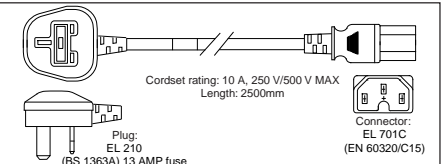
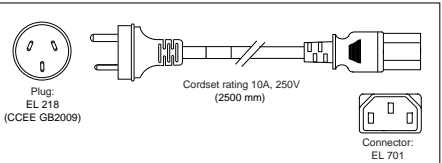
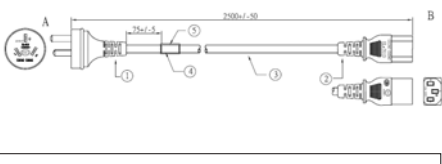
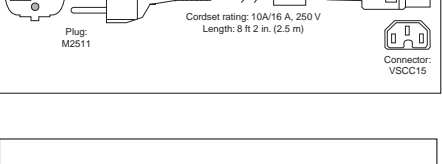
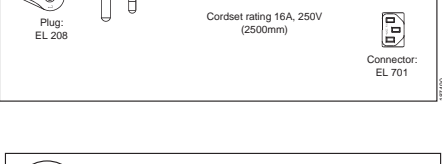
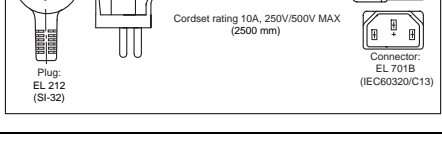
Table 21 Cable Management Arm

Product ID (PID)	PID Description
UCSC-CMA-M4	Reversible CMA for C240 M4 ball bearing rail kit

## STEP 14 ORDER OPTIONAL USB DRIVE



NOTE: A USB drive is available only with the C3X60 M3 server node.

---

You can order one optional USB drive. The USB drive ordering information is listed in [Table 22](#).

Table 22    USB Drive

Product ID (PID)	PID Description
UCS-USBFLSHB-16GB	UCS Servers 16 GB Flash USB Drive

---

See [Figure 7 on page 52](#) for the location of the USB connector

## STEP 15 ORDER A TRUSTED PLATFORM MODULE (OPTIONAL)

Trusted Platform Module (TPM) is a computer chip (microcontroller) that can securely store artifacts used to authenticate the platform (server). These artifacts can include passwords, certificates, or encryption keys. A TPM can also be used to store platform measurements that help ensure that the platform remains trustworthy. Authentication (ensuring that the platform can prove that it is what it claims to be) and attestation (a process helping to prove that a platform is trustworthy and has not been breached) are necessary steps to ensure safer computing in all environments.

The TPM ordering information is listed in [Table 23](#).

Table 23 Trusted Platform Module

Product ID (PID)	PID Description
UCSX-TPM1-001	TPM Module For UCS <sup>1</sup>
UCSX-TPM2-002	Trusted Platform Module 2.0 for UCS servers <sup>2</sup>

Notes

1. Order this TPM for systems with C3X60 M3 server nodes (use v2 CPUs)
2. Order this TPM for systems with C3X60 M4 server nodes (use v4 CPUs)



**NOTE:** The TPM module used in this system conforms to TPM v1.2 and 2.0, as defined by the Trusted Computing Group (TCG). It is also SPI-based.

## STEP 16 ORDER A KVM CABLE (OPTIONAL)

The KVM cable provides a connection into the server, providing a DB9 serial connector, a VGA connector for a monitor, and dual USB 2.0 ports for a keyboard and mouse. With this cable, you can create a direct connection to the operating system and the BIOS running on the server.

The KVM cable ordering information is listed in [Table 24](#).

Table 24 KVM Cable

Product ID (PID)	PID Description
N20-BKVM=	KVM cable for server console port

Figure 6 KVM Cable

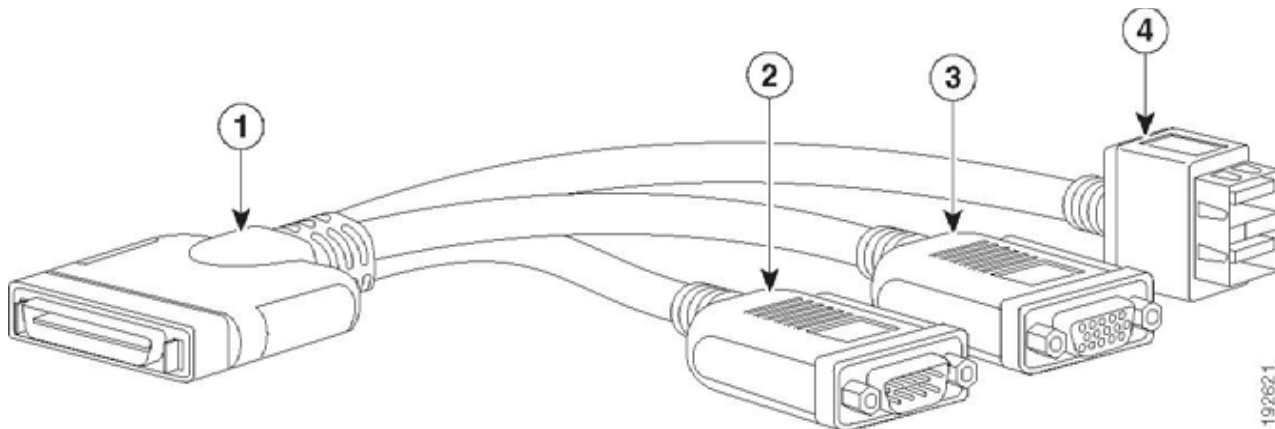

1	Connector (to server front panel)	3	VGA connector (for a monitor)
2	DB-9 serial connector	4	Two-port USB 2.0 connector (for a mouse and keyboard)

## STEP 17 SELECT OPERATING SYSTEM AND VALUE-ADDED SOFTWARE

Several operating systems and value-added software programs are available. Select as desired from [Table 25](#).

Table 25 OSs and Value-Added Software (for 2-CPU servers)

PID Description	Product ID (PID)
<b>Microsoft Windows Server</b>	
MSWS-12-ST2S	Windows Server 2012 Standard (2 CPU/2 VMs)
MSWS-12-DC2S	Windows Server 2012 Datacenter (2 CPU/Unlimited VMs)
MSWS-12-ST2S-NS	Windows Server 2012 Standard (2 CPU/2 VMs) No Cisco SVC
MSWS-12-DC2S-NS	Windows Server 2012 Datacenter (2 CPU/Unlim VM) No Cisco SVC
MSWS-12R2-ST2S	Windows Server 2012 R2 Standard (2 CPU/2 VMs)
MSWS-12R2-DC2S	Windows Server 2012 R2 Datacenter (2 CPU/Unlimited VMs)
MSWS-12R2-ST2S-NS	Windows Server 2012 R2 Standard (2 CPU/2 VMs) No Cisco SVC
MSWS-12R2-DC2S-NS	Windows Server 2012 R2 Datacen (2 CPU/Unlim VM) No Cisco Svc
<b>SUSE</b>	
SLES-2S2V-1A	SUSE Linux Enterprise Svr (1-2 CPU,1 Phys);1yr Support Reqd
SLES-2S2V-3A	SUSE Linux Enterprise Svr (1-2 CPU,1 Phys);3yr Support Reqd
SLES-2S2V-5A	SUSE Linux Enterprise Svr (1-2 CPU,1 Phys);5yr Support Reqd
SLES-2S2V-1S	SUSE Linux Enterprise Svr (1-2 CPU,1-2 VM); Prio 1-Yr SnS
SLES-2S2V-3S	SUSE Linux Enterprise Svr (1-2 CPU,1-2 VM); Prio 3-Yr SnS
SLES-2S2V-5S	SUSE Linux Enterprise Svr (1-2 CPU,1-2 VM); Prio 5-Yr SnS
SLES-2SUV-1A	SUSE Linux Enterprise Svr (1-2 CPU,Unl Vrt);1yr Support Reqd
SLES-2SUV-3A	SUSE Linux Enterprise Svr (1-2 CPU,Unl Vrt);3yr Support Reqd
SLES-2SUV-5A	SUSE Linux Enterprise Svr (1-2 CPU,Unl Vrt);5yr Support Reqd
SLES-2SUV-1S	SUSE Linux Enterprise Svr (1-2 CPU,Unl VM); Prio 1-Yr SnS
SLES-2SUV-3S	SUSE Linux Enterprise Svr (1-2 CPU,Unl VM); Prio 3-Yr SnS
SLES-2SUV-5S	SUSE Linux Enterprise Svr (1-2 CPU,Unl VM); Prio 5-Yr SnS
SLES-2S-HA-1S	SUSE Linux High Availability Ext (1-2 CPU); 1yr Support Reqd
SLES-2S-HA-3S	SUSE Linux High Availability Ext (1-2 CPU); 3yr Support Reqd
SLES-2S-HA-5S	SUSE Linux High Availability Ext (1-2 CPU); 5yr Support Reqd
SLES-2S-GC-1S	SUSE Linux GEO Clustering for HA (1-2 CPU); 1yr Sns
SLES-2S-GC-3S	SUSE Linux GEO Clustering for HA (1-2 CPU); 3yr Sns
SLES-2S-GC-5S	SUSE Linux GEO Clustering for HA (1-2 CPU); 5yr Sns
<b>VMware 5</b>	
VMW-VS5-STD-1A	VMware vSphere 5 Standard for 1 Processor, 1 Year, Support Rqd
VMW-VS5-STD-2A	VMware vSphere 5 Standard for 1 Processor, 2 Year, Support Rqd
VMW-VS5-STD-3A	VMware vSphere 5 Standard for 1 Processor, 3 Year, Support Rqd
VMW-VS5-STD-4A	VMware vSphere 5 Standard for 1 Processor, 4 Year, Support Rqd
VMW-VS5-STD-5A	VMware vSphere 5 Standard for 1 Processor, 5 Year, Support Rqd

Table 25 OSs and Value-Added Software (for 2-CPU servers) *(continued)*

PID Description	Product ID (PID)
VMW-VS5-ENT-1A	VMware vSphere 5 Enterprise for 1 Processor, 1 Year Support Rqd
VMW-VS5-ENT-2A	VMware vSphere 5 Enterprise for 1 CPU, 2 Yr Support Rqd
VMW-VS5-ENT-3A	VMware vSphere 5 Enterprise for 1 CPU, 3 Yr Support Rqd
VMW-VS5-ENT-4A	VMware vSphere 5 Enterprise for 1 Processor, 4 Year Support Rqd
VMW-VS5-ENT-5A	VMware vSphere 5 Enterprise for 1 CPU, 5 Yr Support Rqd
VMW-VS5-ENTP-1A	VMware vSphere 5 Enterprise Plus for 1 Processor, 1 Year Support Rqd
VMW-VS5-ENTP-2A	VMware vSphere 5 Enterprise Plus for 1 CPU, 2 Yr Support Rqd
VMW-VS5-ENTP-3A	VMware vSphere 5 Enterprise Plus for 1 Processor, 3 Year Support Rqd
VMW-VS5-ENTP-4A	VMware vSphere 5 Enterprise Plus for 1 Processor, 4 Year Support Rqd
VMW-VS5-ENTP-5A	VMware vSphere 5 Enterprise Plus for 1 Processor, 5 Year Support Rqd
VMW-VC5-STD-1A	VMware vCenter 5 Server Standard, 1 yr support required
VMW-VC5-STD-2A	VMware vCenter 5 Server Standard, 2 yr support required
VMW-VC5-STD-3A	VMware vCenter 5 Server Standard, 3 yr support required
VMW-VC5-STD-4A	VMware vCenter 5 Server Standard, 4 yr support required
VMW-VC5-STD-5A	VMware vCenter 5 Server Standard, 5 yr support required
UCS-VMW-TERMS	Acceptance of Terms, Standalone VMW License for UCS Servers
<b>Red Hat</b>	
RHEL-2S2V-1A	Red Hat Enterprise Linux (1-2 CPU,1-2 VN); 1-Yr Support Req
RHEL-2S2V-3A	Red Hat Enterprise Linux (1-2 CPU,1-2 VN); 3-Yr Support Req

## STEP 18 SELECT OPERATING SYSTEM MEDIA KIT

Select the optional operating system media listed in [Table 26](#).

Table 26 OS Media

Product ID (PID)	PID Description
RHEL-6	RHEL 6 Recovery Media Only (Multilingual)
MSWS-12-ST2S-MD	Windows Server 2012 Standard (2 CPU/2 VMs) Recovery Media
MSWS-12-DC2S-MD	Windows Server 2012 Datacenter(2 CPU/Unlimited VM) Rec Media
MSWS-12R2-ST2S-RM	Windows Server 2012 R2 Standard (2 CPU/2 VMs) Recovery Media
MSWS-12R2-DC2S-RM	Windows Server 2012 R2 Datacen(2 CPU/Unlimited VM) Rec Media

## STEP 19 SELECT SERVICE and SUPPORT LEVEL

A variety of service options are available, as described in this section.

### Unified Computing Warranty, No Contract

If you have noncritical implementations and choose to have no service contract, the following coverage is supplied:

- Three-year parts coverage.
- Next business day (NBD) onsite parts replacement eight hours a day, five days a week.
- 90-day software warranty on media.
- Ongoing downloads of BIOS, drivers, and firmware updates.

### SMARTnet for UCS

For support of the entire Unified Computing System, Cisco offers the Cisco SMARTnet for UCS Service. This service provides expert software and hardware support to help sustain performance and high availability of the unified computing environment. Access to Cisco Technical Assistance Center (TAC) is provided around the clock, from anywhere in the world.

Smart Call Home provides proactive, embedded diagnostics and real-time alerts. The Cisco SMARTnet for UCS Service includes flexible hardware replacement options, including replacement in as little as two hours. There is also access to Cisco's extensive online technical resources to help maintain optimal efficiency and uptime of the unified computing environment. You can choose a desired service listed in [Table 27](#).

Table 27 Cisco SMARTnet for UCS Service

Product ID (PID)	On Site?	Description
CON-PREM-S3260BSE	Yes	ONSITE 24X7X2 UCS S3260 Server
CON-OSP-S3260BSE	Yes	ONSITE 24X7X4 UCS S3260 Server
CON-OSE-S3260BSE	Yes	ONSITE 8X5X4 UCS S3260 Server
CON-OS-S3260BSE	Yes	ONSITE 8X5XNBD UCS S3260 Server
CON-S2P-S3260BSE	No	SMARTNET 24X7X2 UCS S3260 Server
CON-SNTP-S3260BSE	No	SMARTNET 24X7X4 UCS S3260 Server
CON-SNTE-S3260BSE	No	SMARTNET 8X5X4 UCS S3260 Server
CON-SNT-S3260BSE	No	SMARTNET 8X5XNBD UCS S3260 Server

### SMARTnet for UCS Hardware Only Service

For faster parts replacement than is provided with the standard Cisco Unified Computing System warranty, Cisco offers the Cisco SMARTnet for UCS Hardware Only Service. You can choose from two levels of advanced onsite parts replacement coverage in as little as four hours. SMARTnet for UCS Hardware Only Service provides remote access any time to Cisco support professionals who can determine if a return materials authorization (RMA) is required. You can choose a service listed in [Table 28](#).

Table 28 SMARTnet for UCS Hardware Only Service

Product ID (PID)	Service Level GSP	On Site?	Description
CON-UCW7-S3260BSE	UCW7	Yes	UC PLUS 24X7X40S UCS S3260 Server
CON-UCW5-S3260BSE	UCW5	Yes	UC PLUS 8X5XNBDOS UCS S3260 Server

### Unified Computing Partner Support Service

Cisco Partner Support Service (PSS) is a Cisco Collaborative Services service offering that is designed for partners to deliver their own branded support and managed services to enterprise customers. Cisco PSS provides partners with access to Cisco's support infrastructure and assets to help them:

- Expand their service portfolios to support the most complex network environments
- Lower delivery costs
- Deliver services that increase customer loyalty

Partner Unified Computing Support Options enable eligible Cisco partners to develop and consistently deliver high-value technical support that capitalizes on Cisco intellectual assets. This helps partners to realize higher margins and expand their practice.

PSS is available to all Cisco PSS partners, but requires additional specializations and requirements. For additional information, see the following URL:

[www.cisco.com/go/partnerucssupport](http://www.cisco.com/go/partnerucssupport)

The two Partner Unified Computing Support Options include:

- Partner Support Service for UCS
- Partner Support Service for UCS Hardware Only

Partner Support Service for UCS provides hardware and software support, including triage support for third party software, backed by Cisco technical resources and level three support.

See [Table 29](#).

Table 29 Partner Support Service for UCS

Product ID (PID)	Service Level GSP	On Site?	Description
CON-PSJ1-S3260BSE	PSJ1	No	UCS SUPP PSS 8X5XNBD UCS S3260 Server
CON-PSJ2-S3260BSE	PSJ2	No	UCS SUPP PSS 8X5X4 UCS S3260 Server
CON-PSJ3-S3260BSE	PSJ3	No	UCS SUPP PSS 24X7X4 UCS S3260 Server
CON-PSJ4-S3260BSE	PSJ4	No	UCS SUPP PSS 24X7X2 UCS S3260 Server
CON-PSJ6-S3260BSE	PSJ6	Yes	UCS SUPP PSS 8X5X4 Onsite UCS S3260 Server
CON-PSJ7-S3260BSE	PSJ7	Yes	UCS SUPP PSS 24X7X4 Onsite UCS S3260 Server
CON-PSJ8-S3260BSE	PSJ8	Yes	UCS SUPP PSS 24X7X2 Onsite UCS S3260 Server

Partner Support Service for UCS Hardware Only provides customers with replacement parts in as little as two hours. See [Table 30](#).

Table 30 Partner Support Service for UCS (Hardware Only)

Product ID (PID)	Service Level GSP	On Site?	Description
CON-PSW2-S3260BSE	PSW2	No	UCS W PL PSS 8X5X4 UCS S3260 Server
CON-PSW3-S3260BSE	PSW3	No	UCS W PL PSS 24X7X4 UCS S3260 Server
CON-PSW4-S3260BSE	PSW4	No	UCS W PL PSS 24X7X2 UCS S3260 Server
CON-PSW6-S3260BSE	PSW6	Yes	UCS W PL PSS 8X5XX4 Onsite UCS S3260 Server
CON-PSW7-S3260BSE	PSW7	Yes	UCS W PL PSS 24X7X4 Onsite UCS S3260 Server

### Cisco Combined Services

Combined Services makes it easier to purchase and manage required services under one contract. SMARTnet services for UCS help increase the availability of your vital data center infrastructure and realize the most value from your unified computing investment. The more benefits you realize from the Cisco Unified Computing System (Cisco UCS), the more important the technology becomes to your business. These services allow you to:

- Optimize the uptime, performance, and efficiency of your UCS
- Protect your vital business applications by rapidly identifying and addressing issues
- Strengthen in-house expertise through knowledge transfer and mentoring

- Improve operational efficiency by allowing UCS experts to augment your internal staff resources
- Enhance business agility by diagnosing potential issues before they affect your operations

Unified Computing Drive Retention Service

With the Cisco Unified Computing Drive Retention (UCDR) Service, you can obtain a new disk drive in exchange for a faulty drive without returning the faulty drive. In exchange for a Cisco replacement drive, you provide a signed Certificate of Destruction (CoD) confirming that the drive has been removed from the system listed, is no longer in service, and has been destroyed.

Sophisticated data recovery techniques have made classified, proprietary, and confidential information vulnerable, even on malfunctioning disk drives. The UCDR service enables you to retain your drives and ensures that the sensitive data on those drives is not compromised, which reduces the risk of any potential liabilities. This service also enables you to comply with regulatory, local, and federal requirements.

If your company has a need to control confidential, classified, sensitive, or proprietary data, you might want to consider one of the Drive Retention Services listed in [Table 31](#), [Table 32](#), or [Table 33](#).



NOTE: Cisco does not offer a certified drive destruction service as part of this service.

Table 31 Drive Retention Service Options

Service Description	Service Program Name	Service Level GSP	Service Level	Product ID (PID)
SMARTnet for UCS Service with Drive Retention	UCS DR	UCSD7	24x7x4 Onsite	CON-UCSD7-S3260BSE
		UCSD5	8x5xNBD Onsite	CON-UCSD5-S3260BSE
SMARTnet for UCS HW ONLY+Drive Retention	UCS HW+DR	UCWD7	24x7x4 Onsite	CON-UCWD7-S3260BSE
		UCWD5	8x5xNBD Onsite	CON-UCWD5-S3260BSE

Table 32 Drive Retention Service Options for Partner Support Service

Service Description	Service Level GSP	Service Level	Product ID (PID)
Partner Support Service for UCS Drive Retention	PSJD6	8x5x4 Onsite	CON-PSJD6-S3260BSE
	PSJD7	24x7x4 Onsite	CON-PSJD7-S3260BSE

Table 33 Drive Retention Service Options for Partner Support Service (Hardware Only)

Service Description	Service Level GSP	Service Level	Product ID (PID)
Partner Support Service for UCS Drive Retention Hardware only	PSWD6	8x5x4 Onsite	CON-PSWD6-S3260BSE
	PSWD7	24x7x4 Onsite	CON-PSWD7-S3260BSE

For more service and support information, see the following URL:

[http://www.cisco.com/en/US/services/ps2961/ps10312/Unified\\_Computing\\_Services\\_Overview.pdf](http://www.cisco.com/en/US/services/ps2961/ps10312/Unified_Computing_Services_Overview.pdf)

For a complete listing of available services for Cisco Unified Computing System, see this URL:

[http://www.cisco.com/en/US/products/ps10312/serv\\_group\\_home.html](http://www.cisco.com/en/US/products/ps10312/serv_group_home.html)

## OPTIONAL STEP - ORDER RACK(S)

The optional R42612 rack is available from Cisco for the C-Series servers, including the C240 M4 SFF server. This rack is a standard 19-inch rack and can be ordered with a variety of options, as listed in [Table 34](#). Racks are shipped separately from the C240 M4 SFF server.

Table 34 Racks and Rack Options

Product ID (PID)	PID Description
RACK2-UCS	Cisco R42612 expansion rack, no side panels.  This type of rack is used for multiple-rack deployments.
RACK2-UCS2	Cisco R42612 static (standard) rack, with side panels.  This type of rack is used for single-rack and end of row deployments. Side panels are needed for racks at the ends of multiple-rack deployments. For example, when configuring a row of 5 racks, order 1 standard rack plus 4 expansion racks. Apply the side panels from the standard rack to the racks at each end of the row.
RACK-BLANK-001	Blanking panels (qty 12), 1U, plastic, toolless.  Recommended to ensure proper airflow. Fill all empty RU spaces in the front of the rack. Because each blanking panel PID includes 12 panels, use the following calculation: 42RU - occupied RU = available RU. Divide available RU by 12 to determine PID order quantity.
RACK-CBLMGT-001	Cable mgt D rings (qty 10), metal.  Use the D rings to bundle system cables to ensure proper airflow.
RACK-CBLMGT-003	Brush strip (qty 1), 1 U.  The brush strip promotes proper airflow while allowing cables to be passed from the front to the rear of the rack.
RACK-CBLMGT-011	Cable mgt straps (qty 10), Velcro.  Use the Velcro straps to bundle system cables to ensure proper airflow.
RACK-FASTEN-001	Mounting screws (qty 100), M6.  The rack ships with nuts and screws, but extras may be ordered.
RACK-FASTEN-002	Cage nuts (qty 50), M6.  The rack ships with nuts and screws, but extras may be ordered.
RACK2-JOIN-001	Rack joining kit.  Use the kit to connect adjacent racks within a row. Order 1 unit less than the number of racks in the row.
RACK2-GRND-001	Cisco R42612 grounding kit

For more information about the R42612 rack, see [RACKS, page 59](#).

## OPTIONAL STEP - ORDER PDU

An optional power distribution unit (PDU) is available from Cisco for the C-Series rack servers, including the C240 M4 server. This PDU is available in a zero rack unit (RU) style or horizontal PDU style (see [Table 35](#)). For more information about the PDU, see [PDUs, page 61](#).

Table 35 Available PDUs

Product ID (PID)	Description	Plug	Country
<b>Zero-RU PDUs</b>			
RP208-30M1P-6-36	30 A, single-phase, vertical-mount PDU with 6 C19 and 36 C13 connectors	L6-30P	North America
RP208-30M3P-6-30	30 A, three-phase, vertical-mount PDU with 6 C19 and 30 C13 connectors	L15-30P	North America
RP208-60M3P-12-9	60 A, three-phase, vertical-mount PDU with 12 C19 and 9 C13 connectors	IEC60309 460P9	North America
RP230-32M1P-6-36	32 A, single-phase, button-mount (rear and sides) PDU with 6 C19 and 36 C13 connectors	IEC60309 332P6	International
RP230-32M3P-12-12	32 A, single-phase, button-mount (rear and sides) PDU with 12 C19 and 12 C13 connectors	IEC60309 532P6	International
<b>Horizontal PDUs (occupy RU space)</b>			
RP208-30M1P-4-8 (1 RU space)	30 A, single-phase, horizontal-mount PDU with 4 C19 and 8 C13 connectors	L6-30P	North America
RP208-60M3P-12 (2 RU spaces)	48 A, three-phase, horizontal-mount PDU with 12 C19 connectors	L15-30P	North America

# SUPPLEMENTAL MATERIAL

## CHASSIS

An internal view of the Cisco UCS S3260 chassis with the top cover removed is shown in *Figure 7*.

Figure 7 Cisco UCS S3260 Server With Top Cover Off

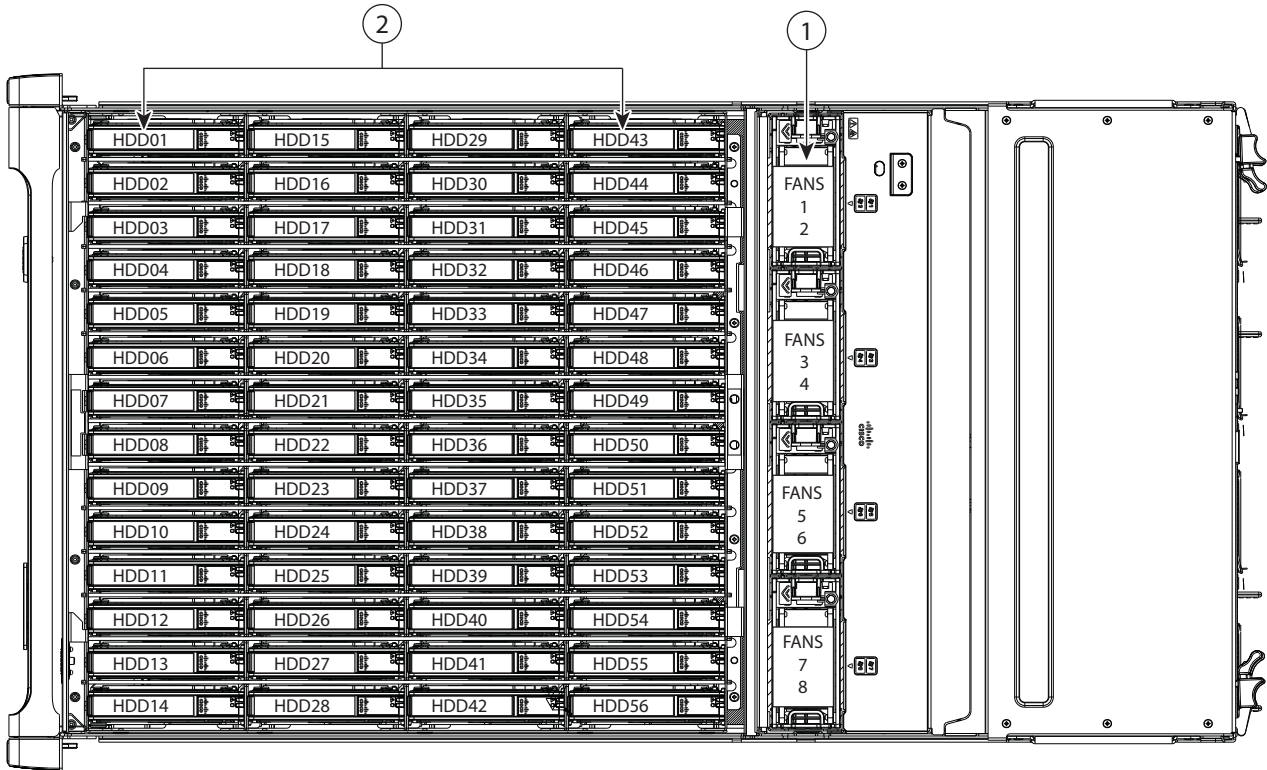

<p>1</p>	<p>Fan modules (four, hot-swappable) Each fan module contains two fans. Even numbers are upper fans, odd numbers are lower fans.</p>	<p>2</p>	<p>Internal drive bays (up to 56 2.5-inch drives, hot-swappable)</p>
----------	--	----------	--

## CPUs and DIMMs

### C3X60 M3 Server Node Physical Layout

Each CPU has four DIMM channels:

- CPU1 has channels A, B, C, and D
- CPU2 has channels E, F, G, and H

Each DIMM channel has two slots: slot 1 and slot 2. The blue-colored DIMM slots are for slot 1 and the black-colored slots for slot 2.

As an example, DIMM slots A1, B1, C1, and D1 belong to slot 1, while A2, B2, C2, and D2 belong to slot 2.

*Figure 8* shows how slots and channels are physically laid out on the motherboard. The DIMM slots on the right half of the motherboard (channels A, B, C, and D) are associated with CPU 1, while the DIMM slots on the left half of the motherboard (channels E, F, G, and H) are associated with CPU 2. The slot 1 (blue) DIMM slots are always located farther away from a CPU than the corresponding slot 2 (black) slots. Slot 1 slots (blue) are populated before slot 2 slots (black).

Figure 8 Physical Layout of CPU DIMM Channels and Slots

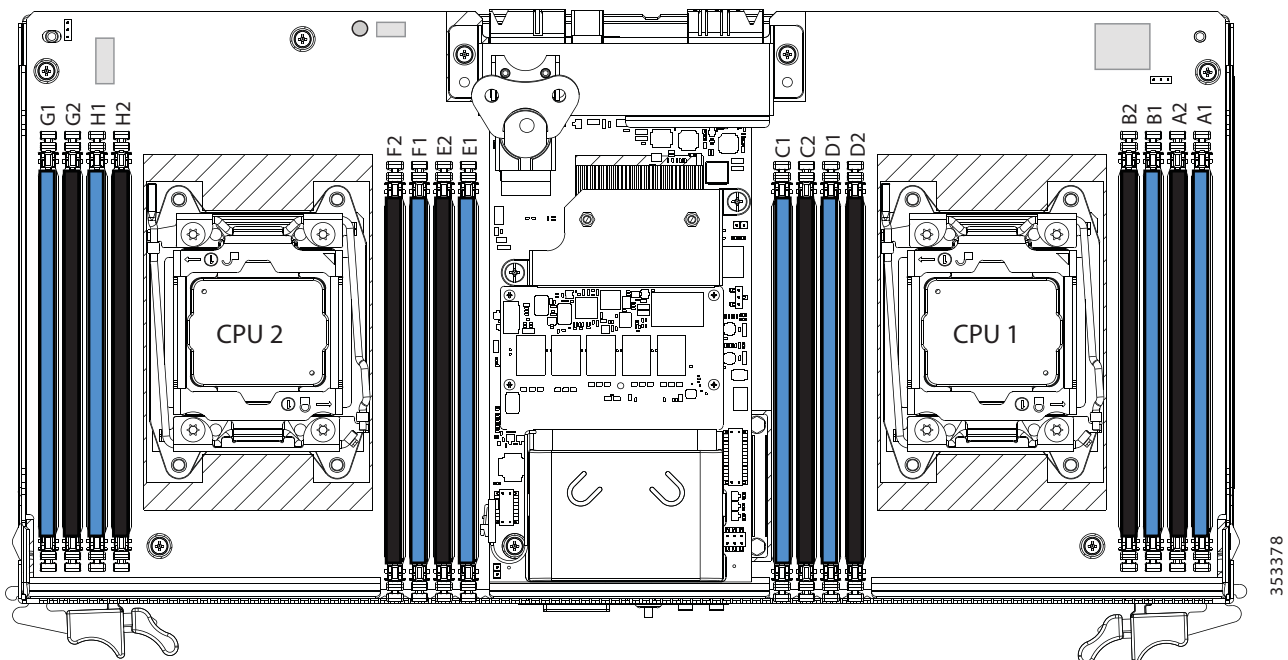

353378

## C3X60 M4 Server Node Physical Layout

Each CPU has four DIMM channels:

- CPU1 has channels A, B, C, and D
- CPU2 has channels E, F, G, and H

Each DIMM channel has two slots: slot 1 and slot 2. The blue-colored DIMM slots are for slot 1 and the black-colored slots for slot 2.

As an example, DIMM slots A1, B1, C1, and D1 belong to slot 1, while A2, B2, C2, and D2 belong to slot 2.

*Figure 8* shows how slots and channels are physically laid out on the motherboard. The DIMM slots on the right half of the motherboard (channels E, F, G, and H) are associated with CPU 2, while the DIMM slots on the left half of the motherboard (channels A, B, C, and D) are associated with CPU 1. The slot 1 DIMM slots are always located farther away from a CPU than the corresponding slot 2 slots. Slot 1 slots are populated before slot 2 slots.

Figure 9 Physical Layout of CPU DIMM Channels and Slots

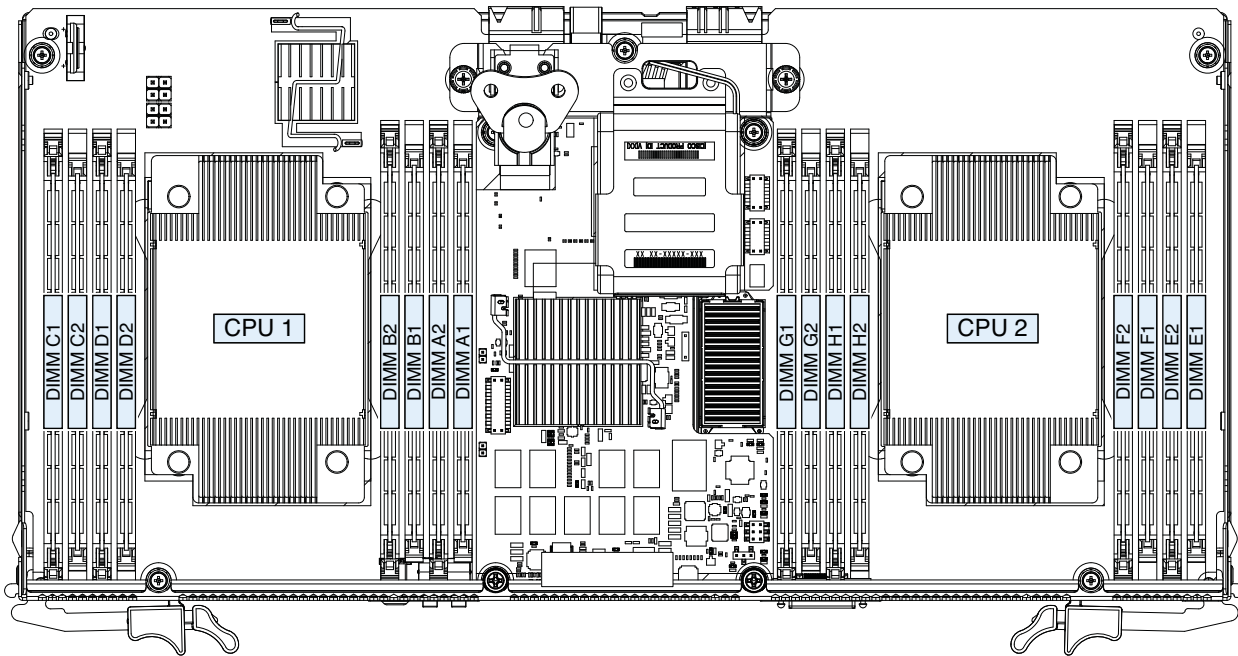

305374

## Memory Population Rules

When considering the memory configuration of your server, consider the following items:

- Each channel has two DIMM slots (for example, channel A = slots A1 and A2).
  - A channel can operate with one or two DIMMs installed.
  - If a channel has only one DIMM, populate slot 1 first.
- When both CPUs are installed, populate the DIMM slots of each CPU identically.
  - Fill blue slots in the channels first: A1, E1, B1, F1, C1, G1, D1, H1
  - Fill black slots in the channels second: A2, E2, B2, F2, C2, G2, D2, H2
- Any DIMM installed in a DIMM socket for which the CPU is absent is not recognized.
- Observe the DIMM mixing rules shown in [Table 36](#)

Table 36 DIMM Rules for Cisco UCS S3260 Servers

DIMM Parameter	DIMMs in the Same Channel	DIMM in the Same Slot <sup>1</sup>
<u>DIMM Capacity</u>		
16 or 32 GB	DIMMs in the same channel (for example, A1 and A2) can have different capacities.	For best performance, DIMMs in the same slot (for example, A1, B1, C1, D1) should have the same capacity.
	Do not mix LRDIMMs with RDIMMs	Do not mix LRDIMMs RDIMMs
<u>DIMM Speed</u>		
1866 MHz for C3X60 M3 2400 MHz for C3X60 M4	DIMMs will run at the lowest speed of the DIMMs/CPUs installed	DIMMs will run at the lowest speed of the DIMMs/CPUs installed
<u>DIMM Type</u>		
RDIMMs or LRDIMMs	Do not mix DIMM types in a channel	Do not mix DIMM types in a slot

### Notes

1. Although different DIMM capacities can exist in the same slot, this will result in less than optimal performance. For optimal performance, all DIMMs in the same slot should be identical.

## Internal Drive Population Guidelines

The system has 56 internal drive bays in the main chassis. *Figure 10* shows the internal drive bay numbering. When populating internal drives, follow these guidelines:

- Populate drive bays as follows:
  - Populate HDDs starting from the lowest-numbered bays to the highest. Populate row 1 - 14, then row 15 - 28, and so on.
  - Populate SSDs starting from the highest-numbered bays to the lowest. Populate bay 56, then bay 55, and so on.

For example, a system with 36 HDDs and 2 SSDs should have the HDDs in bays 1 - 36 and the SSDs in bays 56 and 55..

- The four colored boxes shown in *Figure 10* represent the four power groups in which the power is distributed for the drive bays. This might be useful for troubleshooting power rail problems.

Figure 10 Internal Drive Bay Numbering

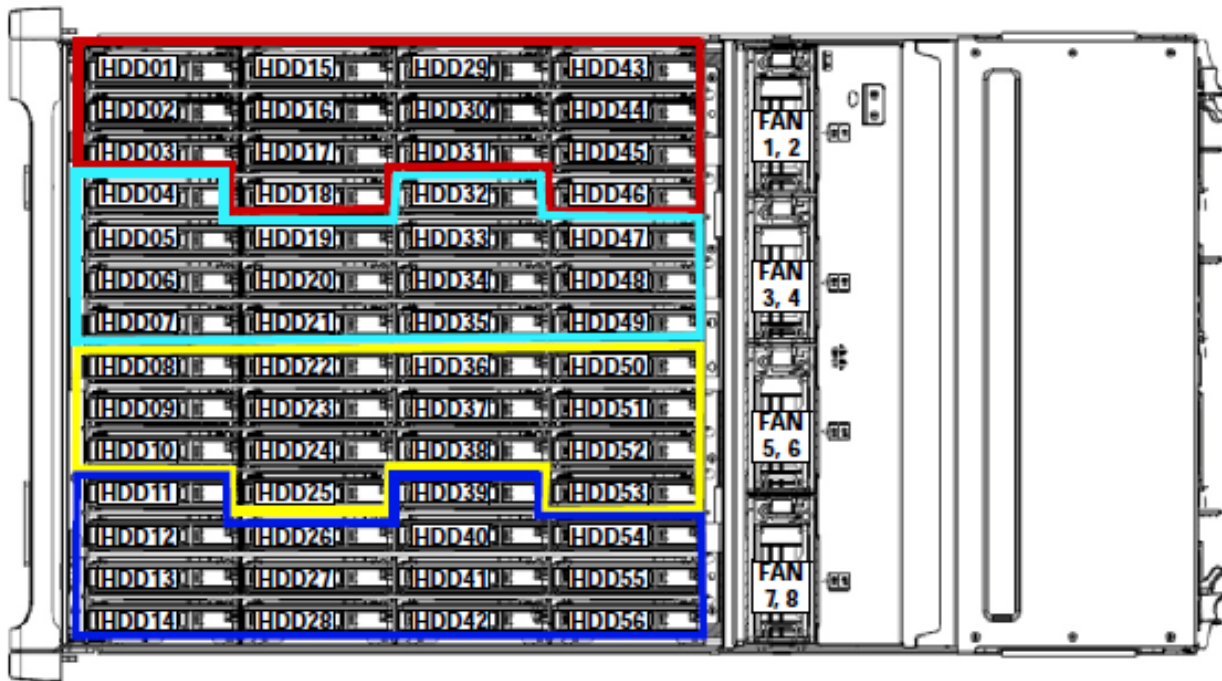

## Upgrade and Servicing-Related Parts

This section lists the upgrade and servicing-related parts you may need during the life of your server. Some of these parts are configured with every server, and some may be ordered when needed or may be ordered and kept on hand as spares for future use. See [Table 37](#).

Table 37 Upgrade and Servicing-related Parts for Cisco UCS S3260 Server

Spare Product ID (PID)	Description
UCSC-S3260-SIOC=	Cisco UCS S3260 System IO Controller with integrated 1300-series virtual interface capability.
UCSC-C3X60-14HD6=	UCS C3X60 1 row of 6 TB NL-SAS 7200 RPM SAS-3 (14 Total) 84 TB
UCSC-C3X60-14HD8=	UCS C3X60 1 row of 8 TB NL-SAS 7200 RPM SAS-3 (14 Total) 112TB
UCSC-C3K-14HD10=	UCS C3X60 1 row of 10 TB NL-SAS drives (14 Total) 140 TB
UCSC-C3X60-EX24T=	Cisco UCS S3260 Expander with 4 x 6TB 7200RPM NL-SAS Drives
UCSC-C3X60-SBLKP=	Cisco UCS C3X60 SIOC blanking plate
UCSC-C3X60-R4GB=	UCS C3X60 12G SAS RAID Controller with 4GB cache
UCSC-C3X60-HBA=	UCS CX260 12G SAS Pass through Controller
UCSC-C3X60-R1GB=	UCS C3X60 12G SAS RAID Controller with 1GB cache
UCSC-HS-C3X60=	Cisco UCS C3X60 Server Node CPU Heatsink FRU
UCS-CPU-GREASE3=	M4 Server CPU thermal grease syringe - needed for heatsink seal <sup>1</sup>
UCSC-PSU1-1050W=	Cisco UCS C3X60 1050W (AC) Power Supply Unit
UCSC-PSUV2-1050DC=	Cisco UCS C3X60 1050W (DC) Power Supply Unit
UCSC-C3X60-FANM=	Cisco UCS C3X60 Fan module containing 2x80mm fans FRU
UCSX-HSCK=	UCS Processor Heat Sink Cleaning Kit (when replacing a CPU) <sup>1</sup>
N20-BKVM=	KVM local IO cable for UCS servers console port
UCSC-C3X60-RAIL=	UCS C3X60 Rack Rails Kit
UCSC-C3X60-R1GB=	UCS C3X60 12G SAS RAID Controller with 1GB cache (SPARE)
UCSC-C3X60-R4GB=	UCS C3X60 12G SAS RAID Controller with 1GB cache (SPARE)
UCS-C3K-M4RAID=	Cisco UCS C3X60 RAID Controller M4 SrvNode w/4G RAID Cache
UCSC-C3X60-BLKP=	Cisco UCS C3X60 Server Node blanking plate (needed if server node slot 2 is empty)
UCSC-C3K-M4SRB=	UCS C3X60 M4 Server Node for Intel E5-2600 v4 (Field Replaceable Unit (FRU) only spare)
UCSC-C3K-M4SRB-U	UCS C3X60 M4 Server Node for Intel E5-2600 v4 (configurable spare)

### Notes

1. These parts should be ordered with the purchase of each optional or spare Intel CPU processor kit so that new thermal grease can be applied. You need the heat sink cleaning kit if you are replacing the CPU but re-using the existing heatsink. It is also needed if you RMA (return) the server node and have to move existing CPUs to the new node. In both these cases you must also have replacement grease.

## System I/O Controller Blanking Panel

A system I/O controller blanking panel (UCSC-C3X60-SBLKP) must be installed if you remove a System I/O controller from the Cisco UCS S3260 server. This panel is required to maintain system temperatures at safe operating levels, and to keep dust away from system components.

## RACKS

The Cisco R42612 rack (see [Figure 11 on page 60](#)) is certified for Cisco UCS installation at customer sites and is suitable for the following equipment:

- Cisco UCS B-Series servers and fabric interconnects
- Cisco UCS C-Series and select Nexus switches

The rack is compatible with hardware designed for EIA-standard 19-inch racks. Rack specifications are listed in [Table 38](#).

Table 38 R42612 Specifications

Cisco R42612 Rack	Standard (Static with side panels)	Expansion (Static without Side Panels)
Dimensions (H x W x D)	79.25 x 23.50 x 49.84 in. (2013 x 597 x 1266 mm)	79.25 x 23.50 x 49.84 in. (2013 x 597 x 1266 mm)
Dimensions (H x W x D) with packaging	84.25 x 32 x 54.84 in. (2140 x 813 x 1393 mm)	84.25 x 32 x 54.84 in. (2140 x 813 x 1393 mm)
Distance from front mounting rail to rear mounting rail	29.19 in. (741.5 mm)	29.19 in. (741.5 mm)
Weight	339.51 lb (154 kg)	264.55 lb (120 kg)
Weight with packaging	410.06 lb (186 kg)	335.10 lb (152 kg)
Side panels included	Yes	No
Equipment mounting capacity	42 RU	42 RU
Static load capacity	2700 lb (1224.7 kg)	2700 lb (1224.7 kg)
Dynamic load capacity	N/A	N/A

Figure 11 Cisco R42612 Rack

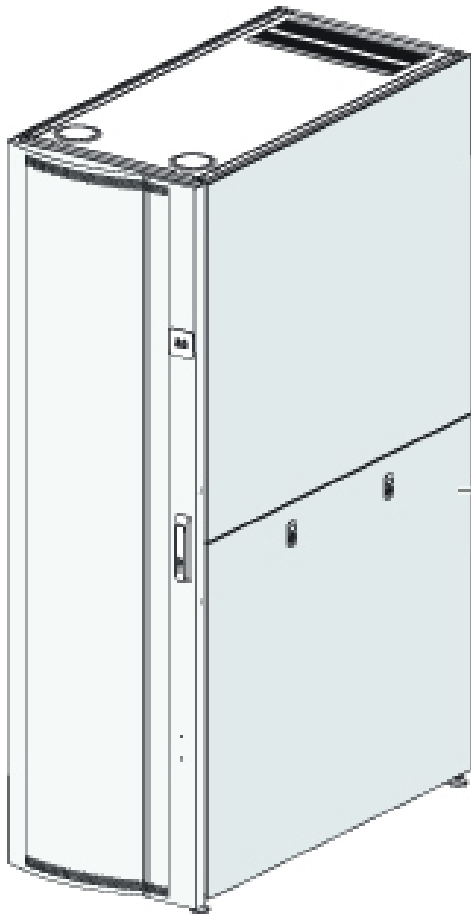

Front View

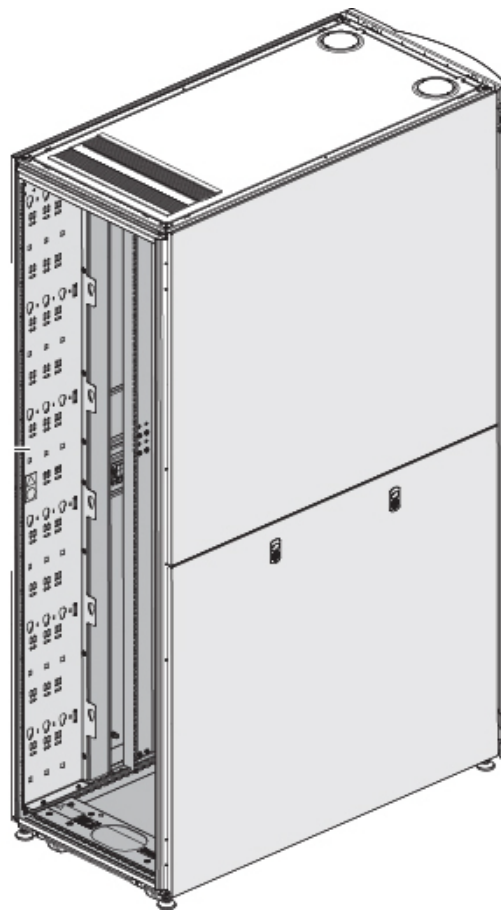

Rear View

## PDU

Cisco RP Series Power Distribution Units (PDUs) offer power distribution with branch circuit protection.

Cisco RP Series PDU models distribute power to up to 42 outlets. The architecture organizes power distribution, simplifies cable management, and enables you to move, add, and change rack equipment without an electrician.

With a Cisco RP Series PDU in the rack, you can replace up to two dozen input power cords with just one. The fixed input cord connects to the power source from overhead or under-floor distribution. Your IT equipment is then powered by PDU outlets in the rack using short, easy-to-manage power cords.

The C-series severs accept the zero-rack-unit (ORU) or horizontal PDU. See [Figure 12](#) for one example of a zero rack unit PDU.

Figure 12 RP208-30M1P-6-36 PDU

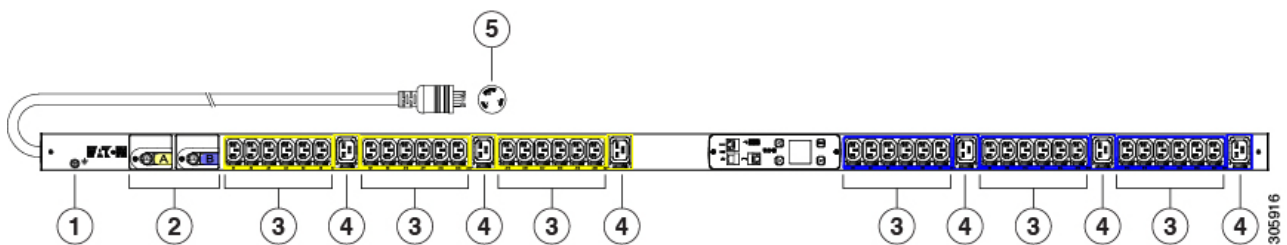

1 = Ground

2 = 20 A circuit breakers

3 = IEC 60320 C13 outlets

4 = EC 60320 C19 outlets

5 = NEMA L6-30P plug

## TECHNICAL SPECIFICATIONS

### Dimensions and Weight

Table 39 Cisco UCS S3260 Dimensions and Weight

Parameter	Value
Height	6.88 in (174 mm)
Width	17.46 in (444 mm)
Depth	32.00 in (813 mm)
Front Clearance	3 in. (76 mm)
Side Clearance	1 in. (25 mm)
Rear Clearance	6 in. (152 mm)
Weight (maximum configuration without rail kit)	195 lbs (88.45 kg)

## Power Specifications

The server is available with 1050 W (AC) or 1050 W (DC) power supplies. The power supply specifications are listed in [Table 40](#) and [Table 41](#).

Table 40 Cisco UCS S3260 1050 W (AC) Power Supply Specifications

Description	Specification
Class	RSP2
AC input voltage	200 to 240 VAC nominal (Range: 180 to 264 VAC)
AC input frequency	50 to 60 Hz nominal (Range: 47 to 63 Hz)
Maximum AC input current	8.5 A at 200 VAC
Maximum output power for each power supply	1050 W on main power 30 W on standby power
Power supply output voltage	Main power: 12 VDC Standby power: 12 VDC
Rated output load	Main power: 116.6 DC Amps Standby power: 2.5 DC Amps

Table 41 Cisco UCS S3260 1050 W (DC) Power Supply Specifications

Description	Specification
DC Input voltage range	Nominal range: -48 to -60 VDC nominal (maximum range: -40 to -72 VDC)
Maximum DC input current	32 A at -40 VDC
Maximum input W	1234 W
Maximum output power per PSU	1050 W on 12 VDC main power 36 W on 12 VDC standby power
Maximum inrush current	15 A at -72 VDC
Maximum hold-up time	5 ms at 100% load (1050 W main and 36 W standby)
Power supply output voltage	12 VDC
Power supply standby voltage	12 VDC
Efficiency rating	Greater than or equal to 92% at 50% load
Form factor	RSP2
Input connector	3 wire Connector (Molex MINIFIT SR. R/A)

For configuration-specific power specifications, use the Cisco UCS Power Calculator at this URL:

<http://ucspowercalc.cisco.com>.

## Environmental Specifications

The power specifications for the Cisco UCS S3260 server are listed in [Table 42](#).

Table 42 Cisco UCS S3260 Environmental Specifications

Parameter	Minimum
Temperature operating	5°C to 35°C (41°F to 95°F)
Temperature nonoperating	-40° C to 65° C (-40° F to 149° F)
Humidity (RH) operating, non-condensing	10% to 90%
Altitude, operating Derated 1° C for each 305 m	0 m to 3048 m (0 ft to 10,000 ft)
Altitude nonoperating	0 m to 12,192 m (0 ft to 40,000 ft)
Acoustic noise, operating	LWAd 5.4 Bel LpAm 38 dBA

## Compliance Requirements

The regulatory compliance requirements for The Cisco UCS S3260 Storage Server are listed in [Table 43](#).

Table 43 Regulatory Compliance Requirements

Parameter	Description
Regulatory Compliance	Products should comply with CE Markings per directives 2004/108/EC and 2006/95/EC
Safety	UL 60950-1 Second Edition CAN/CSA-C22.2 No. 60950-1 Second Edition EN 60950-1 Second Edition IEC 60950-1 Second Edition AS/NZS 60950-1 GB4943 2001
EMC - Emissions	47CFR Part 15 (CFR 47) Class A AS/NZS CISPR22 Class A CISPR22 Class A EN55022 Class A ICES003 Class A VCCI Class A EN61000-3-2 EN61000-3-3 KN22 Class A CNS13438 Class A
EMC - Immunity	EN55024 CISPR24 EN300386 KN24



---

**Americas Headquarters**  
Cisco Systems, Inc.  
San Jose, CA

**Asia Pacific Headquarters**  
Cisco Systems (USA) Pte. Ltd.  
Singapore

**Europe Headquarters**  
Cisco Systems International BV Amsterdam,  
The Netherlands

Cisco has more than 200 offices worldwide. Addresses, phone numbers, and fax numbers are listed on the Cisco Website at [www.cisco.com/go/offices](http://www.cisco.com/go/offices).

Cisco and the Cisco Logo are trademarks of Cisco Systems, Inc. and/or its affiliates in the U.S. and other countries. A listing of Cisco's trademarks can be found at [www.cisco.com/go/trademarks](http://www.cisco.com/go/trademarks). Third party trademarks mentioned are the property of their respective owners. The use of the word partner does not imply a partnership relationship between Cisco and any other company. (1005R)