

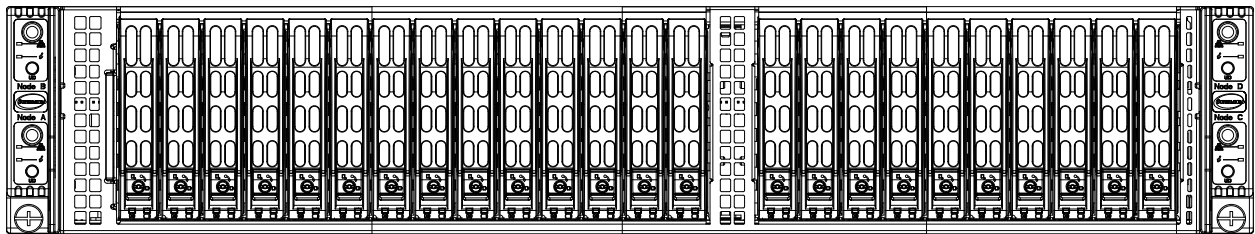

A+ SERVER
AS -2124BT-HTR
AS -2124BT-HNTR



USER'S MANUAL

Revision 1.1a

The information in this User's Manual has been carefully reviewed and is believed to be accurate. The vendor assumes no responsibility for any inaccuracies that may be contained in this document, and makes no commitment to update or to keep current the information in this manual, or to notify any person or organization of the updates. Please Note: For the most up-to-date version of this manual, please see our website at www.supermicro.com.

Super Micro Computer, Inc. ("Supermicro") reserves the right to make changes to the product described in this manual at any time and without notice. This product, including software and documentation, is the property of Supermicro and/or its licensors, and is supplied only under a license. Any use or reproduction of this product is not allowed, except as expressly permitted by the terms of said license.

IN NO EVENT WILL Super Micro Computer, Inc. BE LIABLE FOR DIRECT, INDIRECT, SPECIAL, INCIDENTAL, SPECULATIVE OR CONSEQUENTIAL DAMAGES ARISING FROM THE USE OR INABILITY TO USE THIS PRODUCT OR DOCUMENTATION, EVEN IF ADVISED OF THE POSSIBILITY OF SUCH DAMAGES. IN PARTICULAR, SUPER MICRO COMPUTER, INC. SHALL NOT HAVE LIABILITY FOR ANY HARDWARE, SOFTWARE, OR DATA STORED OR USED WITH THE PRODUCT, INCLUDING THE COSTS OF REPAIRING, REPLACING, INTEGRATING, INSTALLING OR RECOVERING SUCH HARDWARE, SOFTWARE, OR DATA.

Any disputes arising between manufacturer and customer shall be governed by the laws of Santa Clara County in the State of California, USA. The State of California, County of Santa Clara shall be the exclusive venue for the resolution of any such disputes. Supermicro's total liability for all claims will not exceed the price paid for the hardware product.

FCC Statement: This equipment has been tested and found to comply with the limits for a Class A or Class B digital device pursuant to Part 15 of the FCC Rules. These limits are designed to provide reasonable protection against harmful interference when the equipment is operated in industrial environment for Class A device or in residential environment for Class B device. This equipment generates, uses, and can radiate radio frequency energy and, if not installed and used in accordance with the manufacturer's instruction manual, may cause harmful interference with radio communications. Operation of this equipment in a residential area is likely to cause harmful interference, in which case you will be required to correct the interference at your own expense.

California Best Management Practices Regulations for Perchlorate Materials: This Perchlorate warning applies only to products containing CR (Manganese Dioxide) Lithium coin cells. "Perchlorate Material-special handling may apply. See www.dtsc.ca.gov/hazardouswaste/perchlorate".



WARNING: This product can expose you to chemicals including lead, known to the State of California to cause cancer and birth defects or other reproductive harm. For more information, go to www.P65Warnings.ca.gov.

The products sold by Supermicro are not intended for and will not be used in life support systems, medical equipment, nuclear facilities or systems, aircraft, aircraft devices, aircraft/emergency communication devices or other critical systems whose failure to perform be reasonably expected to result in significant injury or loss of life or catastrophic property damage. Accordingly, Supermicro disclaims any and all liability, and should buyer use or sell such products for use in such ultra-hazardous applications, it does so entirely at its own risk. Furthermore, buyer agrees to fully indemnify, defend and hold Supermicro harmless for and against any and all claims, demands, actions, litigation, and proceedings of any kind arising out of or related to such ultra-hazardous use or sale.

Manual Revision 1.1a

Release Date: May 05, 2021

mk

Unless you request and receive written permission from Super Micro Computer, Inc., you may not copy any part of this document. Information in this document is subject to change without notice. Other products and companies referred to herein are trademarks or registered trademarks of their respective companies or mark holders.

Copyright © 2021 by Super Micro Computer, Inc.
All rights reserved.

Printed in the United States of America

Preface

About this Manual

This manual is written for professional system integrators and PC technicians. It provides information for the installation and use of the A+ Server . Installation and maintenance should be performed by experienced technicians only.

Please refer to the AS -2124BT-H(N)TR server specifications page on our website for updates on supported memory, processors and operating systems (<http://www.supermicro.com>).

Notes

For your system to work properly, please follow the links below to download all necessary drivers/utilities and the user's manual for your server.

- Supermicro product manuals: <http://www.supermicro.com/support/manuals/>
- Product drivers and utilities: www.supermicro.com/wdl/driver/AMD/SP3
- Product safety info: http://www.supermicro.com/about/policies/safety_information.cfm

If you have any questions, please contact our support team at:
support@supermicro.com

This manual may be periodically updated without notice. Please check the Supermicro website for possible updates to the manual revision level.

Secure Data Deletion

A secure data deletion tool designed to fully erase all data from storage devices can be found on our website: https://www.supermicro.com/about/policies/disclaimer.cfm?url=/wdl/utility/Lot9_Secure_Data_Deletion_Utility/

Warnings

Special attention should be given to the following symbols used in this manual.



Warning! Indicates important information given to prevent equipment/property damage or personal injury.



Warning! Indicates high voltage may be encountered when performing a procedure.

Contents

Chapter 1 Introduction

1.1 Overview.....	8
1.2 Unpacking the System	8
1.3 System Features	9
1.4 Server Chassis Features.....	10
Control Panel	10
Front Features.....	11
Rear Features	12
Input/Output Ports.....	12
SIOM Network Ports.....	13
Node Trays.....	13
1.5 Motherboard Layout	14
Quick Reference	15
System Block Diagram.....	16
1.6 Where to Get Replacement Components	17
1.7 Returning Merchandise for Service.....	17

Chapter 2 Server Installation

2.1 Overview.....	18
2.2 Preparing for Setup	18
Choosing a Setup Location.....	18
Rack Precautions	18
Server Precautions.....	19
Rack Mounting Considerations	19
Ambient Operating Temperature.....	19
Airflow	19
Mechanical Loading.....	19
Circuit Overloading	20
Reliable Ground.....	20
2.3 Rack Mounting Instructions.....	21
Overview of the Rack Rails.....	21
Adjusting the Rail Length	21
Installing the Rails on a Rack	22
Chassis Installation	23

Chapter 3 Maintenance and Component Installation

3.1 Removing Power	24
Removing Power from a Node.....	24
Removing Power from the System	24
3.2 Accessing the System.....	25
Removing a Computing Node Drawer	25
Removing the Chassis Cover	26
3.3 Motherboard Components.....	27
Processor and Heatsink Installation.....	27
Heatsinks	33
Memory Support and Installation	34
Memory Support	34
DIMM Module Population	35
Installing Memory.....	36
Motherboard Battery	37
3.4 Chassis Components	38
Storage Drives	38
Drive Carriers.....	38
Drive Configuration	39
Installing Drives	40
Installing an M.2 Solid State Drive.....	42
Installing Expansion Cards.....	44
SIOM Card	45
System Fans	46
Checking the Server Air Flow	47
Overheating	47
Power Supply	48

Chapter 4 Motherboard Connections

4.1 Headers and Connectors	49
Front Control Panel Connector	50
4.2 Ports	51
4.3 Jumpers.....	52
4.4 LED Indicators.....	54
4.5 PCI-Express Slots	55

Chapter 5 Software

5.1 Microsoft Windows OS Installation.....56
5.2 Driver Installation.....58
5.3 SuperDoctor® 5.....59
5.4 IPMI60

Chapter 6 BIOS

6.1 Introduction.....61
 Starting BIOS Setup Utility.....61
6.2 Main Setup61
6.3 Advanced Setup Configurations.....63
6.4 IPMI78
6.5 Event Logs81
6.6 Security.....83
6.7 Boot86
6.8 Save & Exit.....88
6.9 BIOS Update Using IPMI90

Appendix A IPMI Crash Dump

Appendix B Standardized Warning Statements for AC Systems

Appendix C System Specifications

Appendix D UEFI BIOS Recovery

Contacting Supermicro

Headquarters

Address: Super Micro Computer, Inc.
980 Rock Ave.
San Jose, CA 95131 U.S.A.

Tel: +1 (408) 503-8000

Fax: +1 (408) 503-8008

Email: marketing@supermicro.com (General Information)
support@supermicro.com (Technical Support)

Website: www.supermicro.com

Europe

Address: Super Micro Computer B.V.
Het Sterrenbeeld 28, 5215 ML
's-Hertogenbosch, The Netherlands

Tel: +31 (0) 73-6400390

Fax: +31 (0) 73-6416525

Email: sales@supermicro.nl (General Information)
support@supermicro.nl (Technical Support)
rma@supermicro.nl (Customer Support)

Website: www.supermicro.nl

Asia-Pacific

Address: Super Micro Computer, Inc.
3F, No. 150, Jian 1st Rd.
Zhonghe Dist., New Taipei City 235
Taiwan (R.O.C)

Tel: +886-(2) 8226-3990

Fax: +886-(2) 8226-3992

Email: support@supermicro.com.tw

Website: www.supermicro.com.tw

Chapter 1

Introduction

1.1 Overview

The Supermicro Big Twin AS -2124BT-H(N)TR is a high-end enterprise server well suited for HPC, Big-Data/Big-Science, or oil and gas enterprises. It is based on the H12DST-B motherboard and the 217BHQ+ chassis with four discrete compute nodes.

AS -2124BT-H(N)TR Models			
System	Drive Type	Power	Chassis Model
AS -2124BT-HTR	24 SATA	2200 W	217BHQ+-R2K22BP2
AS -2124BT-HNTR	24 NVMe/SATA	2200 W	217BHQ+-R2K22BP2

In addition to the motherboards and chassis, several important parts are listed below.

Main Parts List		
Description	Part Number	Quantity
Power supply modules	PWS-2K22A-1R	2
Storage backplanes AS -2124BT-HTR	BPN-SAS3-217BHQ- BPN-ADP-6SATA3-1UB	1 4
Storage backplanes AS -2124BT-HNTR	BPN-SAS3-217BHQ-N4 BPN-ADP-6SATA3H4-1UB	1 4
Fans	FAN-0183L4	4
Heatsinks AS -2124BT-HTR	SNK-P0062PM SNK-P0062PW	4 each
Heatsinks AS -2124BT-HNTR	SNK-P0062P SNK-P0062PW	4 each
Riser cards	RSC-P-6-X2 RSC-PR-6-X2	4 each
Rack mount rails	MCP-290-00144-0N	1 set

1.2 Unpacking the System

Inspect the box the system was shipped in and note if it was damaged in any way. If any equipment appears damaged, please file a damage claim with the carrier who delivered it.

Decide on a suitable location for the rack unit that will hold the server. It should be situated in a clean, dust-free area that is well ventilated. Avoid areas where heat, electrical noise and electromagnetic fields are generated. It will also require a grounded AC power outlet nearby. Be sure to read the precautions and considerations noted in Appendix B.

1.3 System Features

The following is an overview of the main features.

System Features
Motherboard (per node)
H12DST-B
Chassis
217BHQ+
CPU (per node)
Dual AMD EPYC 7003/7002 series processors in SP3 sockets (7003 Series Processor drop-in support requires BIOS version 2.0 or newer)
Chipset
System on Chip
Memory (per node)
In sixteen slots, up to 4 TB of ECC DDR4 3200 MHz speed, RDIMM/LRDIMM/3DS/NVDIMM memory Size up to 256 GB
Storage Drives
Twenty-four hot-swap 2.5" drives total; each node controls six drives AS -2124BT-HTR: SATA AS -2124BT-HNTR: Four U.2 NVMe/SATA and two SATA One M.2 SSD per node, SATA/PCIe 3.0 x4, Form Factor: 2280, 22110; M-Key One SATA DOM per node
Expansion Slots (per node)
Two PCIe 4.0 x16 low profile (6.6" long) slots
Cooling
Four 8-cm mid-chassis fans; two CPU heatsinks per node
Power
Dual 2200 W redundant 80Plus Titanium level modules
Input/Output (per node)
LAN: One SIOM slot (SIOM cards support Ethernet/IB/OPA with speeds ranging from 1G to 100G one dedicated IPMI port USB: Two USB 3.0 type A ports on the rear I/O panel (USB0/1) One USB 2.0 type A header (Internal) One SATA DOM (Device on Module) power connectors One COM port One VGA port
Form Factor
2U rackmount; (WxHxD) 17.6 x 3.5 x 28.8 in. (447 x 88 x 730 mm)

1.4 Server Chassis Features

Control Panel

There are four control panels on the front outside edges of the chassis. Each control panel houses power buttons and status monitoring lights for one node.

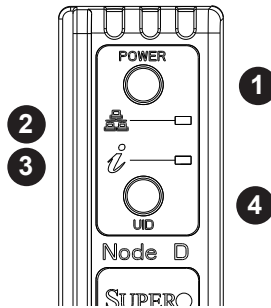

Figure 1-1. Control Panel

Control Panel Features		
Item	Feature	Description
1	Power button	The main power switch applies or removes primary power from the power supply to the node but maintains standby power.
2	NIC LED	Indicates network activity on the LAN when flashing.
3	Information LED	Alerts operator to several states, as noted in the table below
4	UID button/LED	The unit identification (UID) button turns on or off the blue light function of the Information LED and a blue LED on the rear of the chassis. These are used to locate the server in large racks and server banks.

Information LED	
Status	Description
Continuously on and red	An overheat condition has occurred. (This may be caused by cable congestion.)
Blinking red (1Hz)	Fan failure, check for an inoperative fan.
Blinking red (0.25Hz)	Power failure, check for a non-operational power supply.
Solid blue	UID has been activated locally to locate the server in a rack environment.
Blinking blue	UID has been activated using IPMI to locate the server in a rack environment.

Front Features

The chassis front offers access to the storage drives and a control panel for each node.

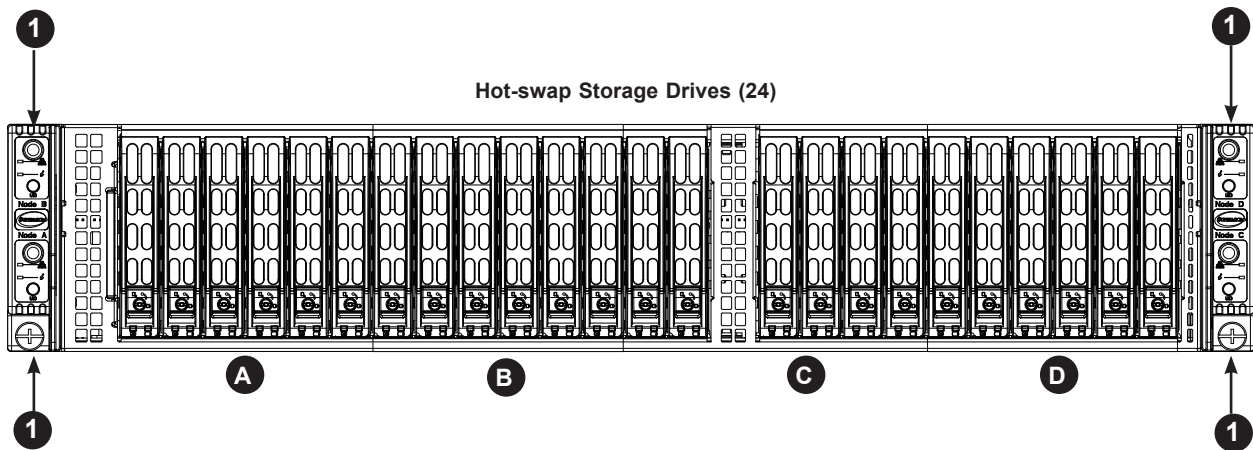

Figure 1-2. Chassis Front View

Front Chassis Features		
Item	Feature	Description
1	Control Panels	Controls a node as labeled
A	Drive bays	Six drives controlled by node A
B	Drive bays	Six drives controlled by node B
C	Drive bays	Six drives controlled by node C
D	Drive bays	Six drives controlled by node D

Rear Features

The illustration below shows the features included on the rear of the chassis.

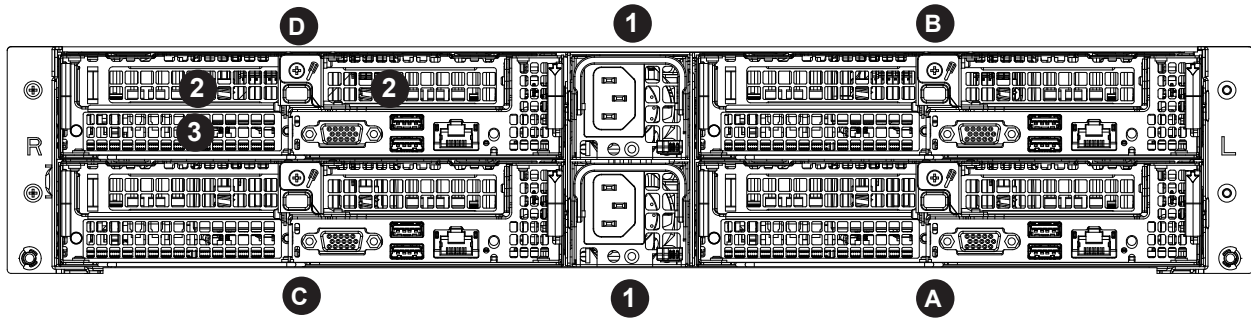

Figure 1-3. Chassis Rear View

Rear Chassis Features		
Item	Feature	Description
A, B, C, D	Node A, B, C, D	Independent computing nodes
1	Power Supplies	Redundant power modules
2	PCI Slots	Two PCIe x16 low profile slots in each node
3	SIOM port	Network ports in each node; refer to table below for available SIOM cards
Unlabeled	I/O ports	Described below

Input/Output Ports

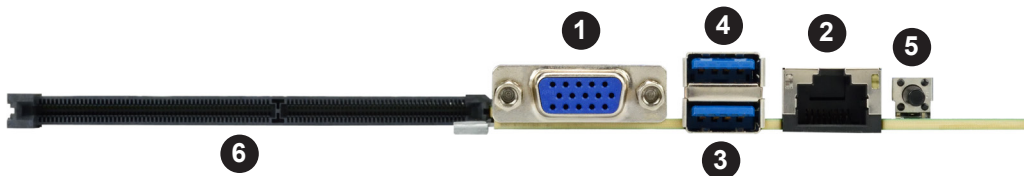

Figure 1-4. Rear I/O Ports

Back Panel I/O Ports			
No.	Description	No.	Description
1	VGA port	4	USB0 (3.0)
2	Dedicated IPMI LAN	5	UID Switch and LED
3	USB1 (3.0)	6	SIOM Network slot

SIOM Network Ports

Network ports are provided by the SIOM card, which offers several choices of connections speeds and types.

SIOM Networking Add-on Card Options		
Speed	Ports	Add-on Card Part Number
GbE	Two RJ45	AOC-MGP-i2M
	Four RJ45	AOC-MGP-i4M
10 G SFP+	Two SFP+	AOC-MTGN-i2SM
	Four SFP+	AOC-MTG-i4SM
10GBase-T	Two RJ45	AOC-MTG-i2TM
25 GbE	Two SFP28 & two RJ45	AOC-MH25G-m2S2TM
	Two SFP28 & two RJ45	AOC-MH25G-b2S2GM
	Two SFP28	AOC-M25G-i2SM
IB FDR	Two QSFP & two RJ45	AOC-MHIBF-m2Q2GM
	One QSFP & two RJ45	AOC-MHIBF-m1Q2GM
IB EDR/100GbE	One QSFP28 & one RJ45	AOC-MHIBE-m1CGM

Updates: https://www.supermicro.com/support/resources/AOC/AOC_Compatibility_SIOM.cfm?show=SELECT&socket=SP3

Node Trays

The chassis contains four separate computing node drawers, each with its own motherboard.

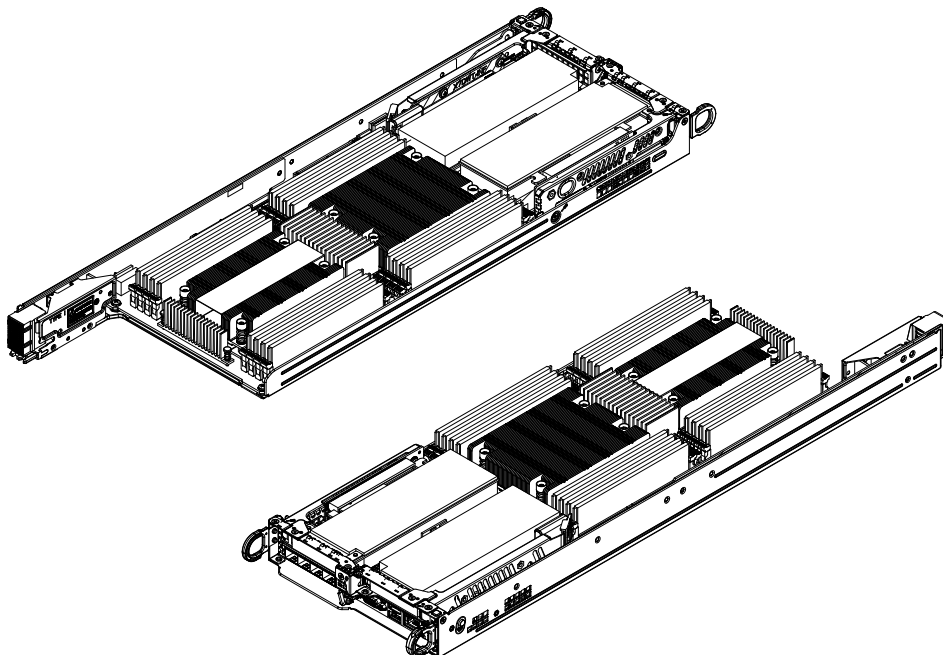

Figure 1-4. Node Tray

1.5 Motherboard Layout

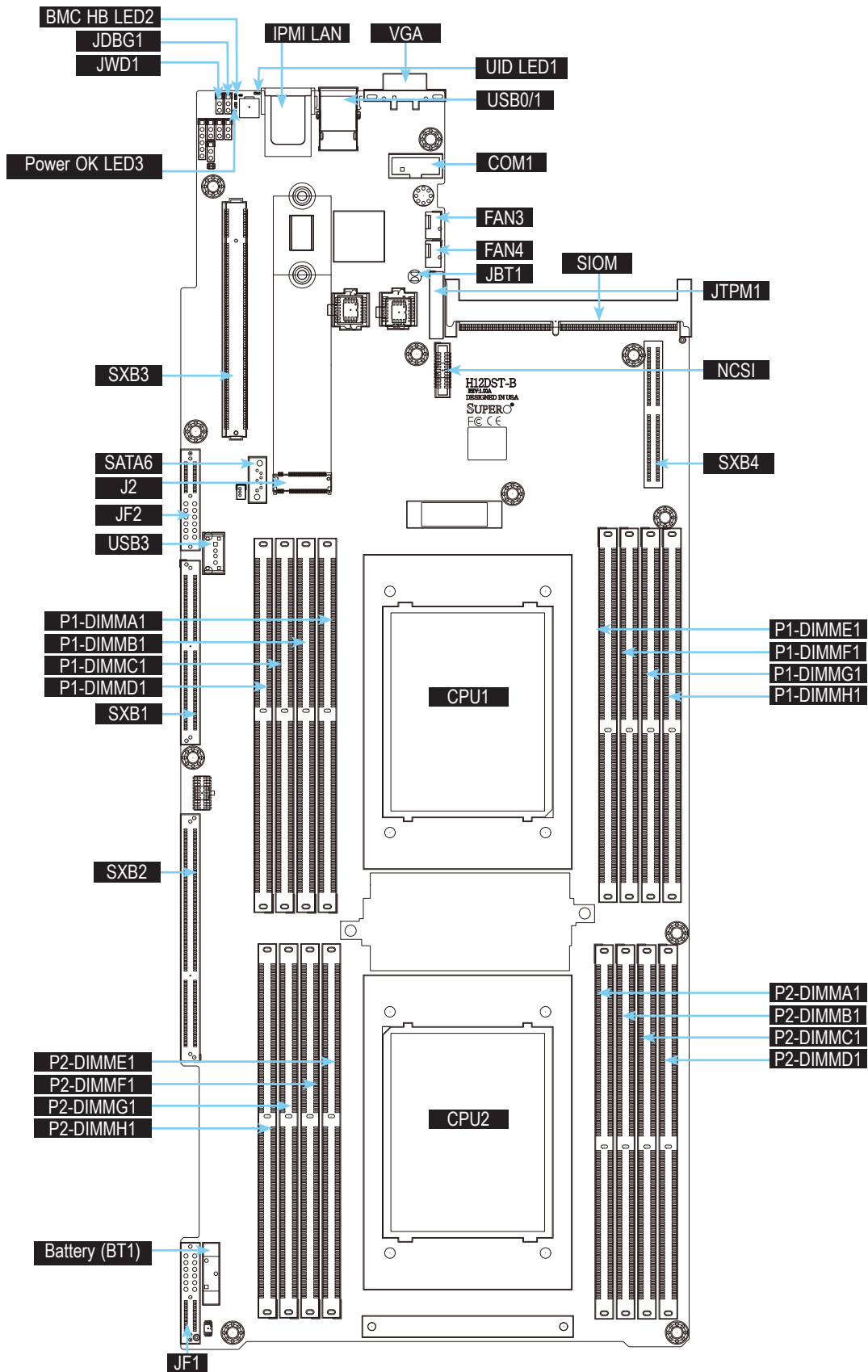

Figure 1-4. Motherboard Layout

Quick Reference

Jumper	Description	Default Setting
UID SW	Unit ID switch (push-button toggle switch ON/OFF)	Off
JBT1	Clear CMOS	Open (Normal)
JDBG1	Debug mode control	Pins 1-2: Normal mode
JWD1	Watch Dog control	Pins 1-2: Reset

Connector	Description
Battery (BT1)	Onboard CMOS battery
COM 1	Front panel COM port #1
FAN 3/4	System cooling fan headers
IPMI_LAN	Dedicated IPMI LAN port
J2	M.2 connector PCIe 3.0 x4 supported by CPU1 and SATA7 connection
JF1	Front control panel
JF2	PCIe 3.0 x4 slot supported by CPU2
JTPM1	Trusted Platform Module (TPM)/Port 80 connector
SIOM	PCIe 4.0 x16 slot for proprietary add-on module supported by CPU1
SXB1	PCIe 3.0 x4 slot supported by CPU2 and SATA connections (SATA0~5) by CPU1
SXB2	PCIe 4.0 x24 slot supported by CPU2
SXB3	PCIe 4.0 x16 left hand riser slot supported by CPU1
SXB4	PCIe 4.0 x16 right hand riser slot supported by CPU1
SATA6	SATA DOM with power-pin connector
NCSI	NC-SI Header for IPMI Support
USB 0/1 (3.0)	Back panel USB 3.0 ports
USB3 (2.0)	Internal USB 2.0 port
VGA	Back panel VGA port

LED	Description	Status
UID LED1	Rear unit ID LED	Solid blue: UID switched to ON, unit identified
BMC_HB LED2	BMC Heartbeat LED	Green: Blinking (BMC normal), Green: Fast blinking (BMC initializing)
PWR_OK LED3	Power OK LED	Green: System power OK

System Block Diagram

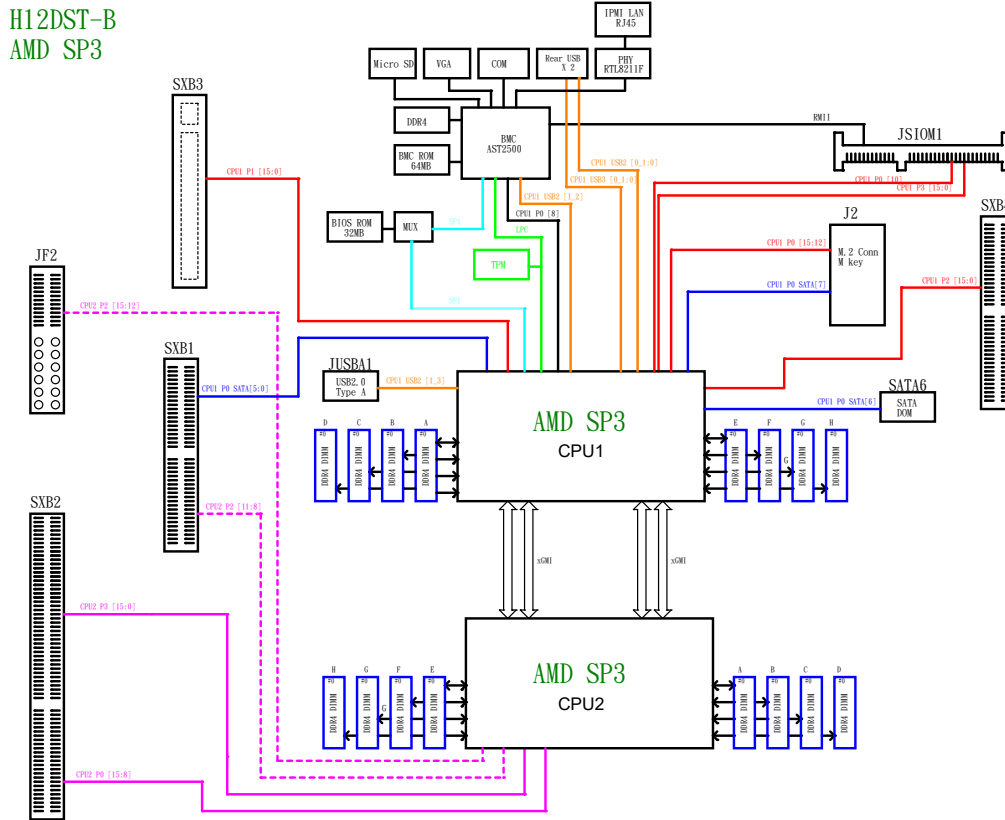

Figure 1-5. System on Chip, System Block Diagram

Note: This is a general block diagram and may not exactly represent the features on your motherboard. See the System Specifications appendix for the actual specifications of your motherboard.

1.6 Where to Get Replacement Components

If you need replacement parts for your system, to ensure the highest level of professional service and technical support, purchase exclusively from our Supermicro Authorized Distributors/System Integrators/Resellers. A list can be found at: <http://www.supermicro.com>. Click the "Where to Buy" link.

1.7 Returning Merchandise for Service

A receipt or copy of your invoice marked with the date of purchase is required before any warranty service will be rendered. You can obtain service by calling your vendor for a Returned Merchandise Authorization (RMA) number. When returning to the manufacturer, the RMA number should be prominently displayed on the outside of the shipping carton, and mailed prepaid or hand-carried. Shipping and handling charges will be applied for all orders that must be mailed when service is complete.

For faster service, RMA authorizations may be requested online (<http://www.supermicro.com/support/rma/>).

Whenever possible, repack the chassis in the original Supermicro carton, using the original packaging material. If these are no longer available, be sure to pack the chassis securely, using packaging material to surround the chassis so that it does not shift within the carton and become damaged during shipping.

This warranty only covers normal consumer use and does not cover damages incurred in shipping or from failure due to the alteration, misuse, abuse or improper maintenance of products.

During the warranty period, contact your distributor first for any product problems.

Chapter 2

Server Installation

2.1 Overview

This chapter provides advice and instructions for mounting your system in a server rack. If your system is not already fully integrated with processors, system memory etc., refer to Chapter 4 for details on installing those specific components.

Caution: Electrostatic Discharge (ESD) can damage electronic components. To prevent such damage to PCBs (printed circuit boards), it is important to use a grounded wrist strap, handle all PCBs by their edges and keep them in anti-static bags when not in use.

2.2 Preparing for Setup

The box in which the system was shipped should include the rackmount hardware needed to install it into the rack. Please read this section in its entirety before you begin the installation.

Choosing a Setup Location

- The system should be situated in a clean, dust-free area that is well ventilated. Avoid areas where heat, electrical noise and electromagnetic fields are generated.
- Leave enough clearance in front of the rack so that you can open the front door completely (~25 inches) and approximately 30 inches of clearance in the back of the rack to allow sufficient space for airflow and access when servicing.
- This product should be installed only in a Restricted Access Location (dedicated equipment rooms, service closets, etc.).
- This product is not suitable for use with visual display workplace devices according to §2 of the German Ordinance for Work with Visual Display Units.

Rack Precautions

- Ensure that the leveling jacks on the bottom of the rack are extended to the floor so that the full weight of the rack rests on them.

- In single rack installations, stabilizers should be attached to the rack. In multiple rack installations, the racks should be coupled together.
- Always make sure the rack is stable before extending a server or other component from the rack.
- You should extend only one server or component at a time - extending two or more simultaneously may cause the rack to become unstable.

Server Precautions

- Review the electrical and general safety precautions in Appendix B.
- Determine the placement of each component in the rack *before* you install the rails.
- Install the heaviest server components at the bottom of the rack first and then work your way up.
- Use a regulating uninterruptible power supply (UPS) to protect the server from power surges and voltage spikes and to keep your system operating in case of a power failure.
- Allow any drives and power supply modules to cool before touching them.
- When not servicing, always keep the front door of the rack and all covers/panels on the servers closed to maintain proper cooling.

Rack Mounting Considerations

Ambient Operating Temperature

If installed in a closed or multi-unit rack assembly, the ambient operating temperature of the rack environment may be greater than the room's ambient temperature. Therefore, consideration should be given to installing the equipment in an environment compatible with the manufacturer's maximum rated ambient temperature (TMRA).

Airflow

Equipment should be mounted into a rack so that the amount of airflow required for safe operation is not compromised.

Mechanical Loading

Equipment should be mounted into a rack so that a hazardous condition does not arise due to uneven mechanical loading.

Circuit Overloading

Consideration should be given to the connection of the equipment to the power supply circuitry and the effect that any possible overloading of circuits might have on overcurrent protection and power supply wiring. Appropriate consideration of equipment nameplate ratings should be used when addressing this concern.

Reliable Ground

A reliable ground must be maintained at all times. To ensure this, the rack itself should be grounded. Particular attention should be given to power supply connections other than the direct connections to the branch circuit (i.e. the use of power strips, etc.).



To prevent bodily injury when mounting or servicing this unit in a rack, you must take special precautions to ensure that the system remains stable. The following guidelines are provided to ensure your safety:

- This unit should be mounted at the bottom of the rack if it is the only unit in the rack.
- When mounting this unit in a partially filled rack, load the rack from the bottom to the top with the heaviest component at the bottom of the rack.
- If the rack is provided with stabilizing devices, install the stabilizers before mounting or servicing the unit in the rack.
- Slide rail mounted equipment is not to be used as a shelf or a work space.

2.3 Rack Mounting Instructions

This section provides information on installing the chassis into a rack unit with the rails provided. There are a variety of rack units on the market, which may mean that the assembly procedure will differ slightly from the instructions provided. You should also refer to the installation instructions that came with the rack unit you are using. **Note:** This rail will fit a rack between 28" and 33.5" deep.

Overview of the Rack Rails

The package includes two rail assemblies. Each is specifically designed for the left or right side of the chassis, and so marked. Each rail consists of two sections: a front section which secures to the front post of the rack and a rear section which adjusts in length and secures to the rear post of the rack.

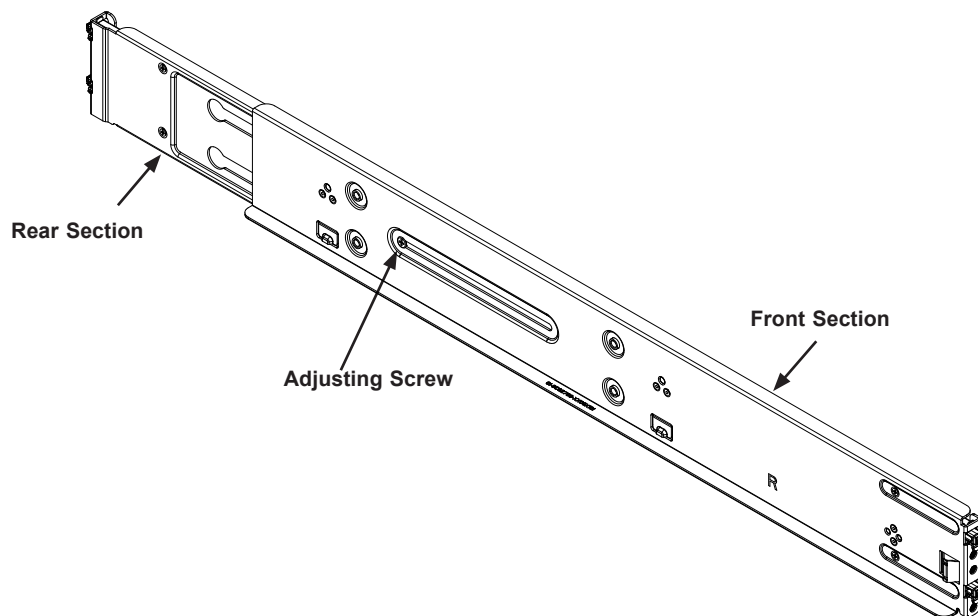

Figure 2-1. Rackmount Rail
(Right rail assembly shown)

Adjusting the Rail Length

Each rail assembly has a locking screw to adjust the length of the rail to fit the depth of your rack.

Installing the Rails on a Rack

1. Loosen the adjusting screw to allow the rear section to slide in the front section.
2. Push the small hooks on the front section of the rail into the holes on the front post of the rack and then down, until the spring-loaded pegs snap into the rack holes. Secure the rail to the rack with screws.
3. Pull out the rear section of the outer rail, adjusting the length until it fits within the posts of the rack and align the small hooks with the appropriate holes on the rear post of the rack. Be sure the rail is level, then mount the rear section onto the rack. Secure the rail with screws.
4. Tighten the adjusting screw.

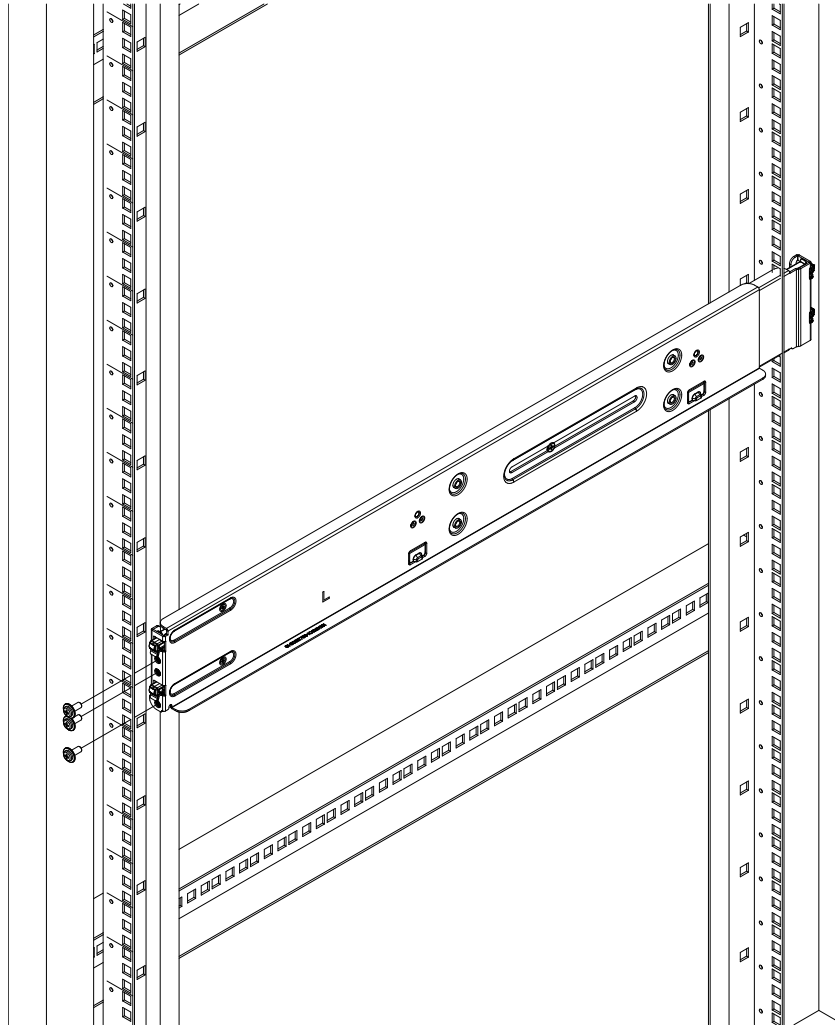

Figure 2-2. Attaching the Rail Front to the Rack
(Left rail shown)

Note: Figures are for illustrative purposes only. Always install servers into racks from the bottom up.

Chassis Installation

Slide the chassis into the rack so that the bottom of the chassis slides onto the bottom lip of the rails.

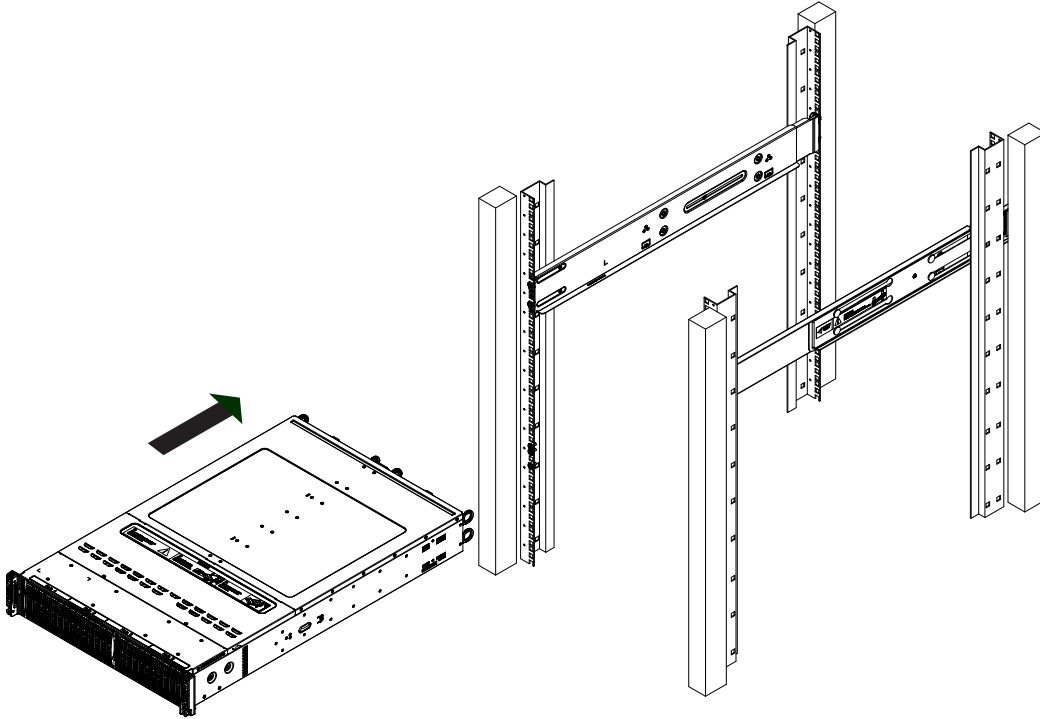

Figure 2-3. Sliding the Chassis into the Rack



Stability hazard. The rack stabilizing mechanism must be in place, or the rack must be bolted to the floor before you slide the unit out for servicing. Failure to stabilize the rack can cause the rack to tip over.

Chapter 3

Maintenance and Component Installation

This chapter provides instructions on installing and replacing main system components. To prevent compatibility issues, only use components that match the specifications and/or part numbers given.

Installation or replacement of most components require that power first be removed from the system. Please follow the procedures given in each section.

3.1 Removing Power

Before performing some setup or maintenance tasks, use the following procedure to ensure that power has been removed from the system.

Removing Power from a Node

1. Use the operating system to power down the node.
2. Grasp the head of the power cord and gently pull it out of the back of the power supply.

Removing Power from the System

1. Use the operating system to power down all nodes.
2. Grasp the head of each power cord and gently pull it out of the back of the power supply.
3. Disconnect the cords from the power strip or wall outlet.

3.2 Accessing the System

Removing a Computing Node Drawer

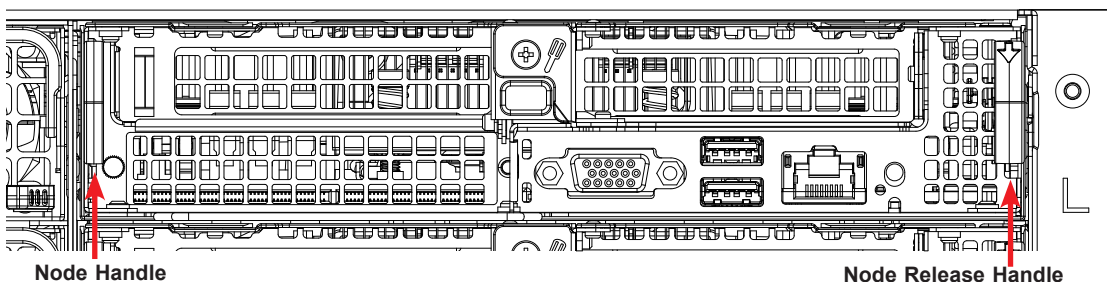

Figure 3-1. Removing a Node Tray

Removing a Node

1. Use the operating system to power down the node.
2. Remove any cables attached to the node
3. Pull down the node release handle and use both handles to slide the node out the chassis rear.

Removing the Chassis Cover

You can access some chassis components, such as fans, by removing the cover.

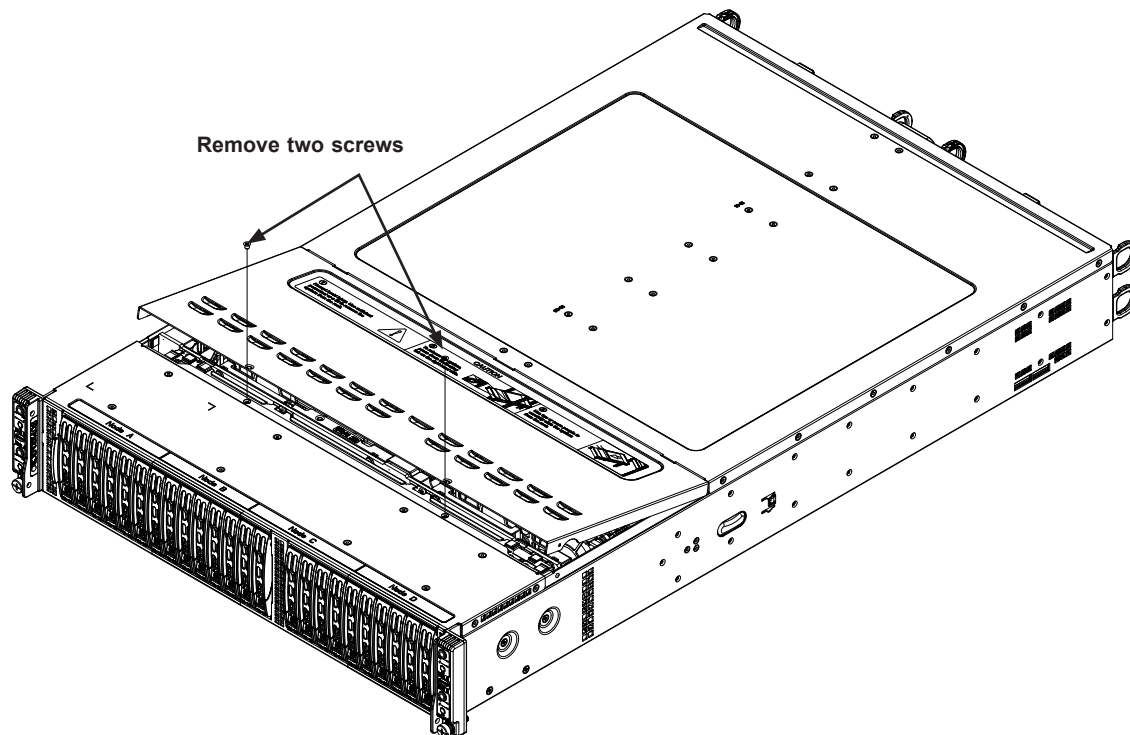

Figure 3-2. Removing the Chassis Cover

Removing the Chassis Cover

The chassis top cover can be lifted off after removing two screws.

Caution: Except for short periods of time, do not operate the server without the cover in place. It provides proper airflow to prevent overheating.

3.3 Motherboard Components

Processor and Heatsink Installation

Notes:

- Use ESD protection.
- Unplug the AC power cord from all power supplies after shutting down the system.
- Check that the plastic protective cover is on the CPU socket and none of the socket pins are bent. If they are, contact your retailer.
- When handling the processor, avoid touching or placing direct pressure on the LGA lands (gold contacts). Improper installation or socket misalignment can cause serious damage to the processor or CPU socket, which may require manufacturer repairs.
- When handling the processor package, avoid placing direct pressure on the label area of the fan.
- Refer to the Supermicro website for updates on processor support.
- All graphics in this manual are for illustration only. Your components may look different.

Installing the Processor and Heatsink

1. Unscrew the screws holding down Force Frame in the sequence of 3-2-1. The screws are numbered on the force frame next to each screw hole.

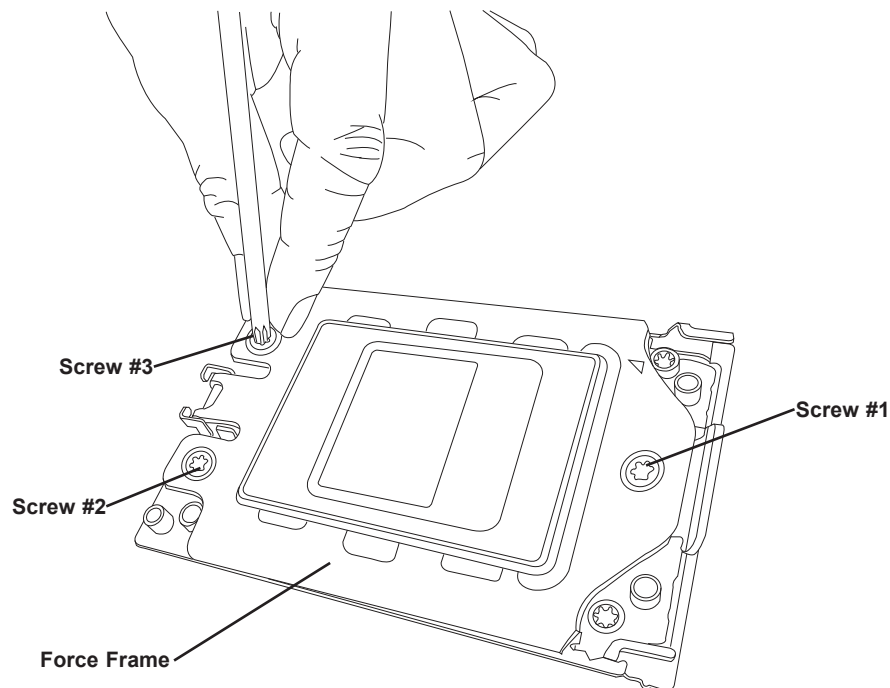

2. The spring-loaded force frame will raise up after the last screw securing it (#1) is removed. Gently allow it to lift up to its stopping position.

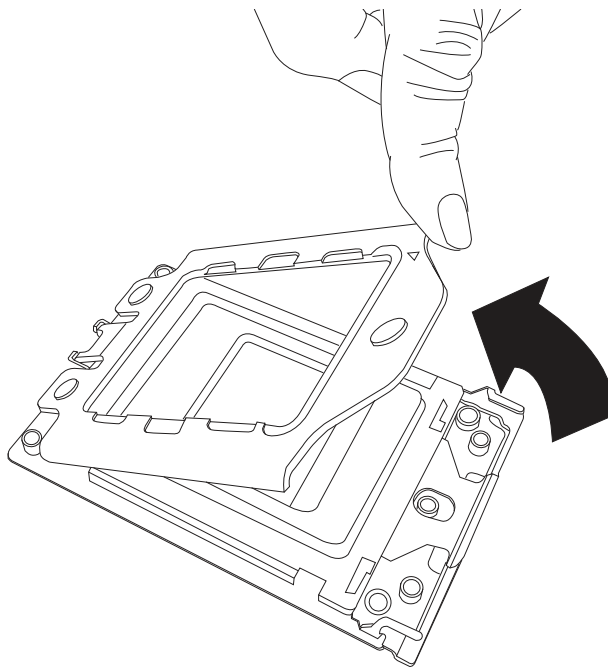

3. Lift the rail frame up by gripping the lift tabs near the front end of the rail frame. While keeping a secure grip of the rail frame, lift it to a position so you can do the next step of removing the external cap.

Note: The rail frame is spring loaded, so keep a secure grip on it as you lift it so it does not snap up.

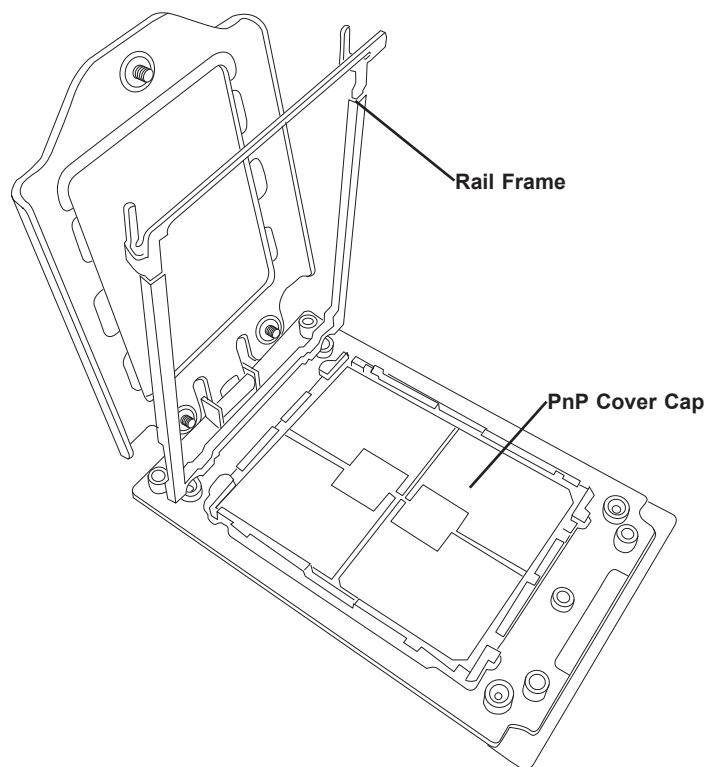

4. Remove the external cap from the Rail Frame by pulling it upwards through the rail guides on the rail frame.

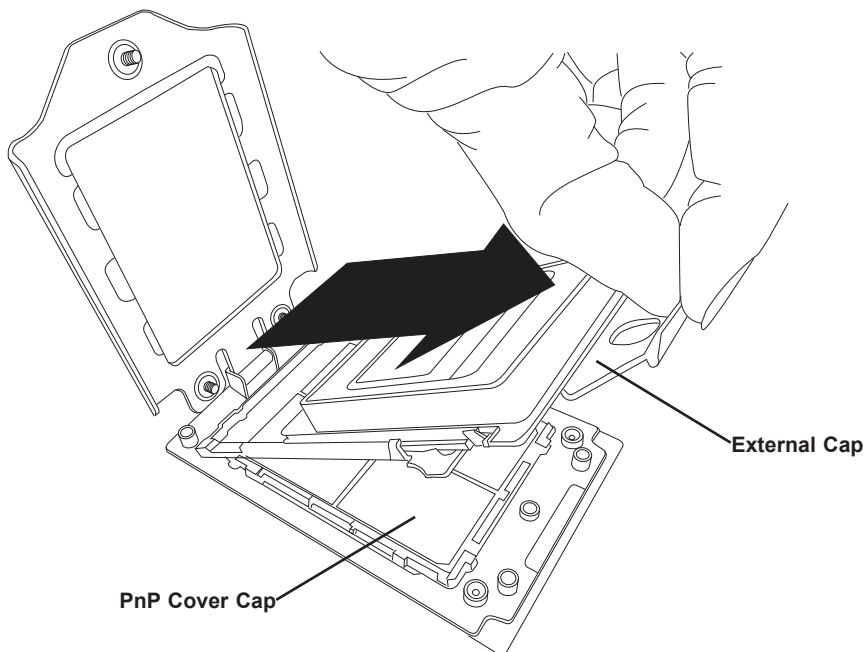

5. The CPU package is shipped from the factory with the carrier frame pre-assembled. Grip the handle of the carrier frame/CPU package assembly from its shipping tray, and while gripping the handle, align the flanges of the carrier frame onto the rails of the rail frame so its pins will be at the bottom when the rail frame is lowered later.
6. Slide the carrier frame/CPU package downwards to the bottom of the rail frame. Ensure the flanges are secure on the rails as you lower it downwards.

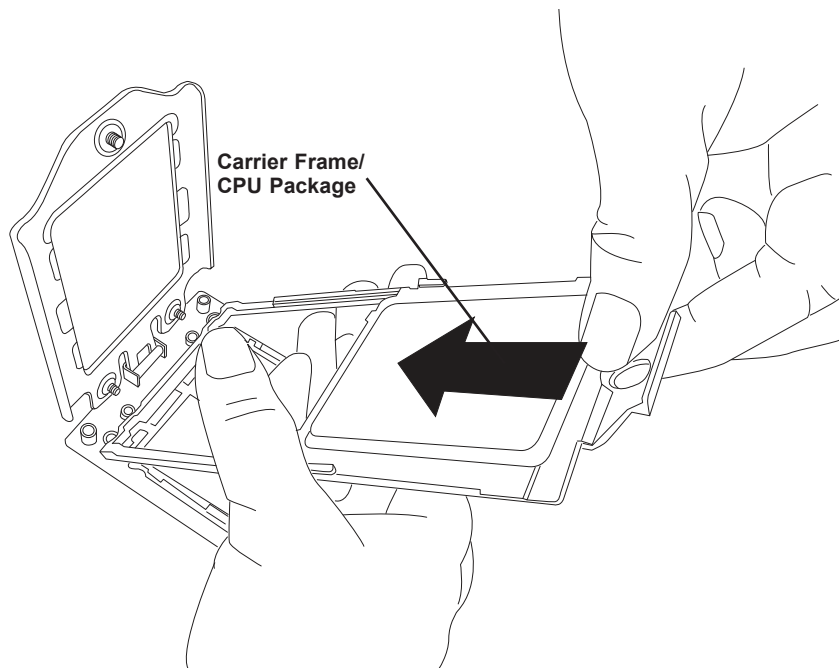

Note: You can only install the CPU inside the socket in one direction with the handle at the top. Make sure that it is properly inserted into the CPU socket before closing the rail frame plate. If it doesn't close properly, do not force it as it may damage your CPU. Instead, open the rail frame plate again, and double-check that the CPU is aligned properly.

7. Lift up the rail frame till it securely rests in upright position. Then remove the PnP cover cap from the CPU socket below. Grip the two lift tabs marked "Remove" at the middle of the cap and pull vertically upwards to remove the PnP cover cap.

Warning! The exposed socket contacts are extremely vulnerable and can be damaged easily. Do not touch or drop objects onto the contacts and be careful removing the PnP cover cap and when placing the rail frame over the socket.

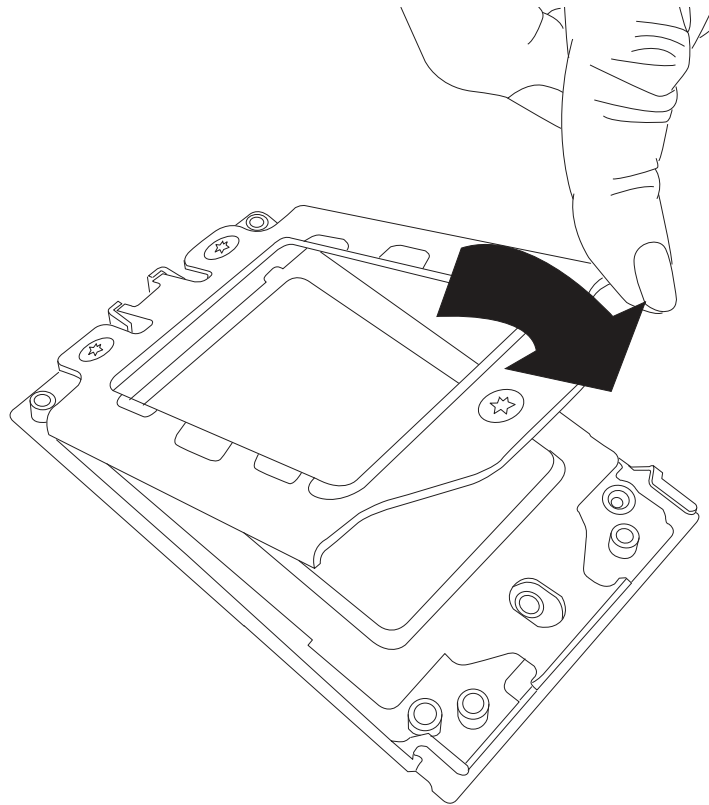

8. Gently lower the rail frame down onto the socket until the latches on the rail frame engage with the socket housing and it rests in place. DO NOT force it into place!
9. Gently lower the force frame down onto the rail frame and hold it in place until it is seated in the Socket housing. Note that the force frame is spring loaded and has to be held in place before it is secured. **Important:** Use a torque screwdriver, set it at 16.1 kgf-cm (14.0 lbf-in) with a Torx T20 screw head bit, to prevent damage to the CPU.

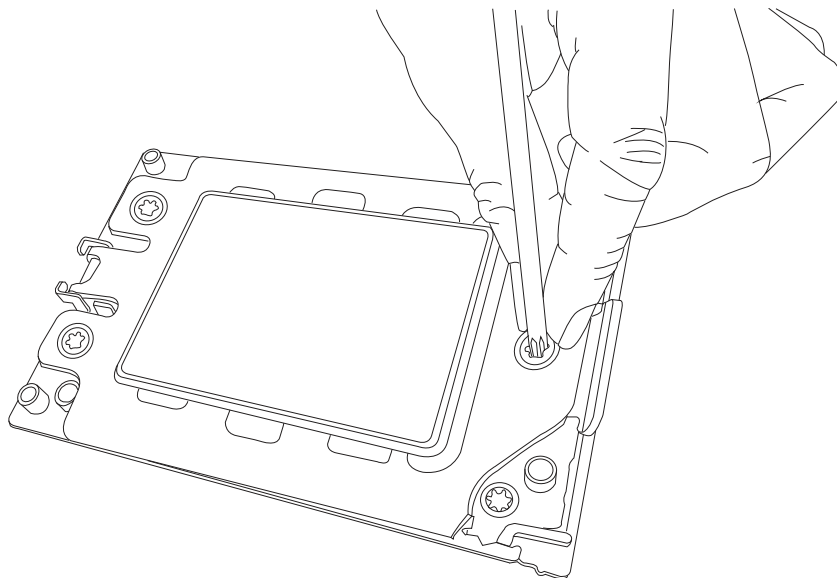

10. Place and re-screw the screws in the reverse order to the way you removed them (holes 1-2-3 in order). When finished, the force frame will be secure over both the rail frame and CPU package.

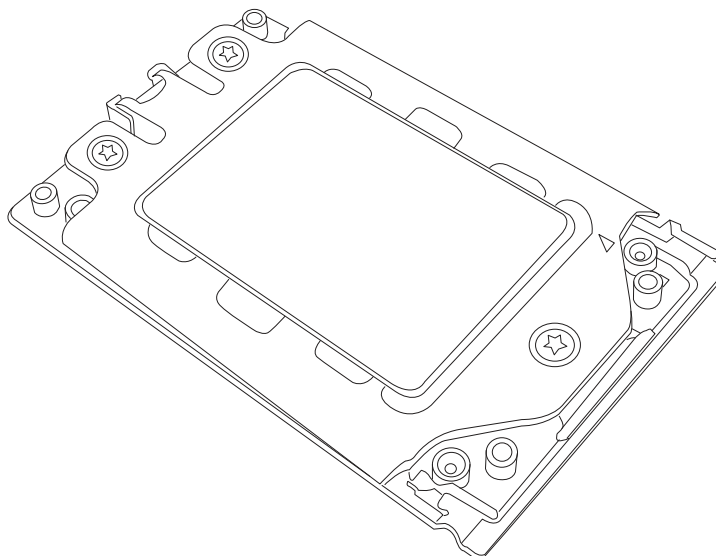

11. After the force frame is secured and the CPU package is in place, now you must install the heatsink to the frame. Lower the heatsink down till it rests securely over the four screw holes on CPU package on the socket frame.

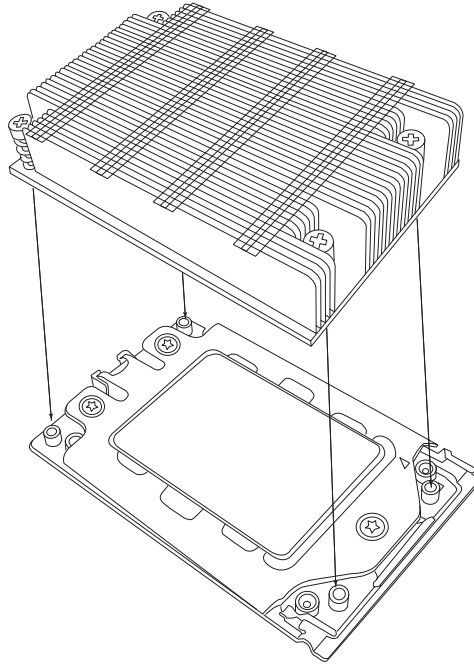

12. Using a diagonal pattern, tighten the four screws down on the heatsink in a clockwise fashion till it is secure. The heatsink will now be secured and you have finished installing the processor and heatsink onto the motherboard. Repeat this procedure for any remaining CPU sockets on the motherboard.

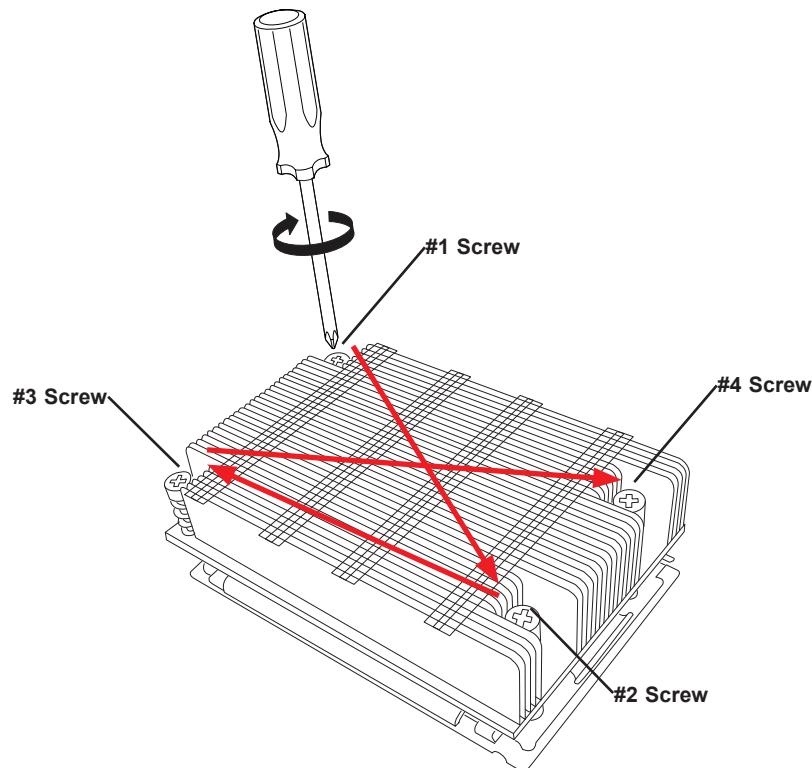

Heatsinks

The AS -2124BT-H(N)TR server uses a slightly different heatsink design for each CPU. The SNK-P0062PM model is used for CPU2, the CPU closer to the mid-chassis fans.

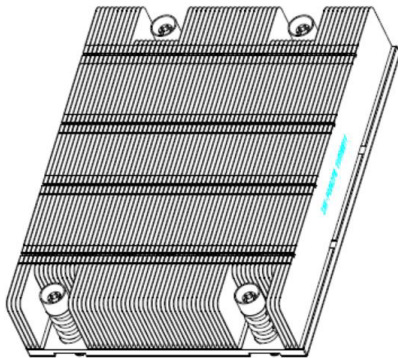

Figure 3-3. Heatsink SNK-P0062PW
(for CPU1)

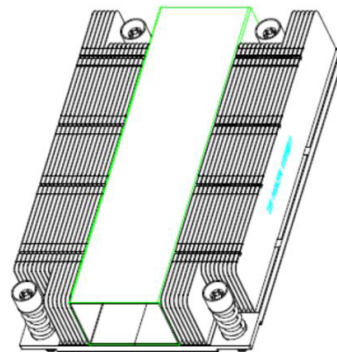

Figure 3-4. Heatsink SNK-P0062PM
(for CPU2)

Uninstalling the Processor and Heatsink

1. Remove the heatsink attached to the top of the CPU package by reversing the installation procedure.
2. Clean the Thermal grease left by the heatsink on the CPU package lid to limit the risk of it contaminating the CPU package land pads or contacts in the socket housing.
3. Reverse the procedure for installing the force frame onto the socket, unscrewing the plate in the 3-2-1 screw order and lift the force frame to the vertical position.
4. Lift the rail frame using the lift tabs near the front end of the rail frame. Note that the rail frame is spring loaded, so be careful lifting it up into a vertical position.
5. Grip the handle of the carrier frame and pull upwards to extract it from the rail frame. Return the carrier frame/CPU package to its original shipping container.
6. Grip the handle on the external cap and return it to the rail frame sliding it downwards till it rests in the frame.
7. Gripping the rail frame, rotate it downwards till it rests above and locks over the socket housing in its horizontal position.
8. Push and rotate down the force frame till it is over the external cap and rail frame into a horizontal position.
9. While holding down the force frame, secure it back to the socket frame by securing screw 1 in place. Note that without a CPU package in place, it is not necessary to tighten down screws 2 and 3 at this time.

Memory Support and Installation

Note: Check the Supermicro website for recommended memory modules.

Important: Exercise extreme care when installing or removing DIMM modules to prevent any possible damage.

Memory Support

The H12DST-B supports up to 4 TB of ECC DDR4 3200 MHz speed, RDIMM/LRDIMM/3DS/NVDIMM memory in sixteen (16) slots.

Processors and their Corresponding Memory Modules									
Channel									
CPU#	D1	C1	B1	A1	CPU	E1	F1	G1	H1
2 DIMMs (Not Recommended)									
CPU1		V							
CPU2		V							
4 DIMMs (Not Recommended)									
CPU1	V	V							
CPU2	V	V							
8 DIMMs									
CPU1	V	V						V	V
CPU2	V	V						V	V
12 DIMMs (for 7003 CPU only)									
CPU1	V	V		V		V		V	V
CPU2	V	V		V		V		V	V
16 DIMMs									
CPU1	V	V	V	V		V	V	V	V
CPU2	V	V	V	V		V	V	V	V

Populating RDIMM/RDIMM 3DS/LRDIMM/LRDIMM 3DS DDR4 Memory Modules				
Type	DIMM Population	Maximum DIMM Capacity (GB)		Maximum Frequency (MHz)
		1 Channel	8 Channels	
RDIMM	1R (1 Rank)	32GB	256GB	3200
	2R or 2DR (2 Ranks)	64GB	512GB	3200
LRDIMM	4DR (4 Ranks)	128GB	1TB	3200
	2S2R (4 Ranks)	128GB	1TB	3200
	2S4R (8 Ranks)	256GB	2TB	3200
LRDIMM 3DS	2S2R (4 Ranks)	128GB	1TB	3200
	2S4R (8 Ranks)	256GB	2TB	3200

DIMM Module Population

- Always use DDR4 DIMM modules of the same type, size and speed.
- Mixed DIMM speeds can be installed. However, all DIMMs will run at the speed of the slowest DIMM.
- The motherboard will support odd-numbered modules (1 or 3 modules installed). However, to achieve the best memory performance, fully populate the motherboard with validated memory modules.

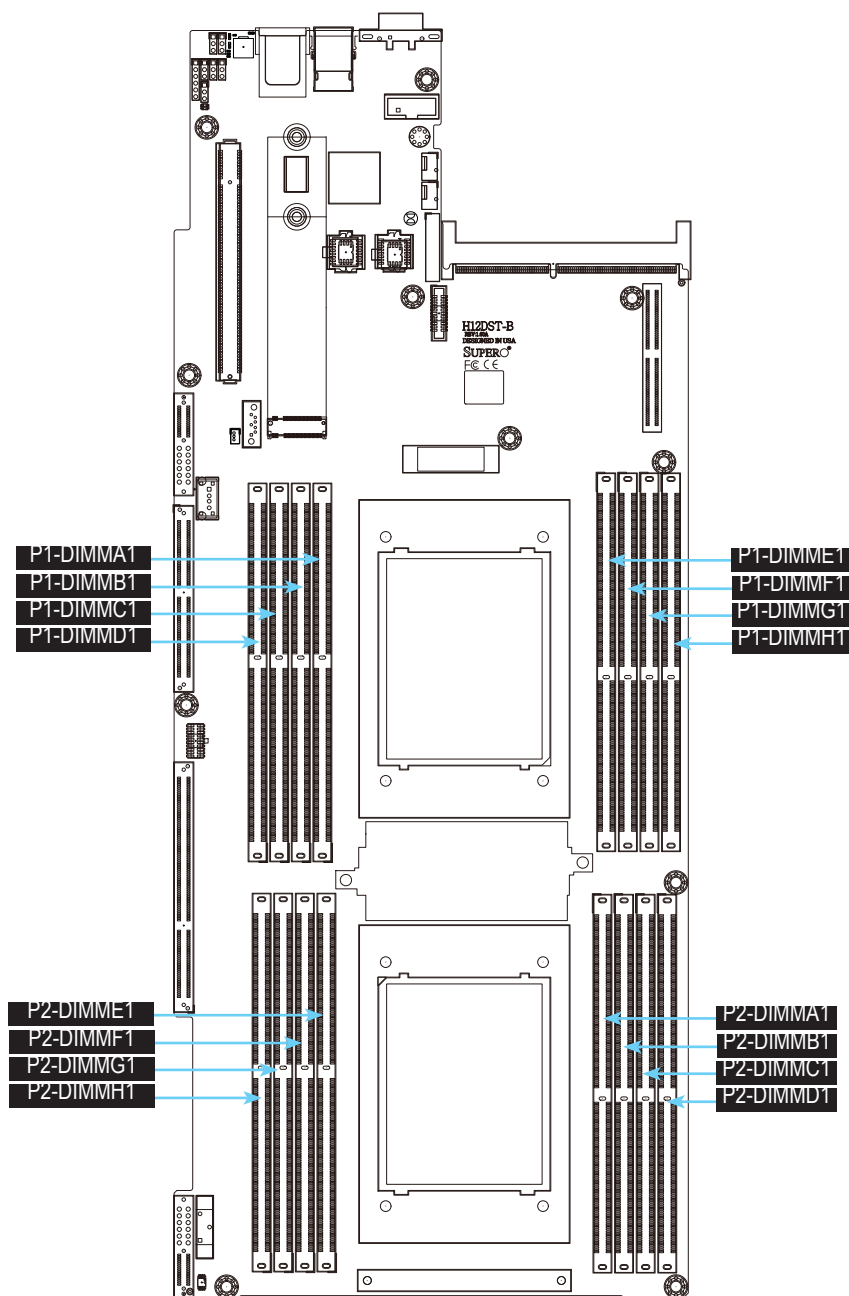

Figure 3-5. DIMM Numbering

Installing Memory

ESD Precautions

Electrostatic Discharge (ESD) can damage electronic components including memory modules. To avoid damaging DIMM modules, it is important to handle them carefully. The following measures are generally sufficient.

- Use a grounded wrist strap designed to prevent static discharge.
- Handle the memory module by its edges only.
- Put the memory modules into the antistatic bags when not in use.

Installing Memory

Begin by removing power from the system as described in Section 3.1. Follow the memory population sequence in the table above.

1. Push the release tabs outwards on both ends of the DIMM slot to unlock it.

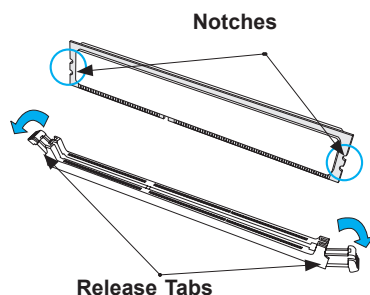

2. Align the key of the DIMM with the receptive point on the memory slot and with your thumbs on both ends of the module, press it straight down into the slot until the module snaps into place.

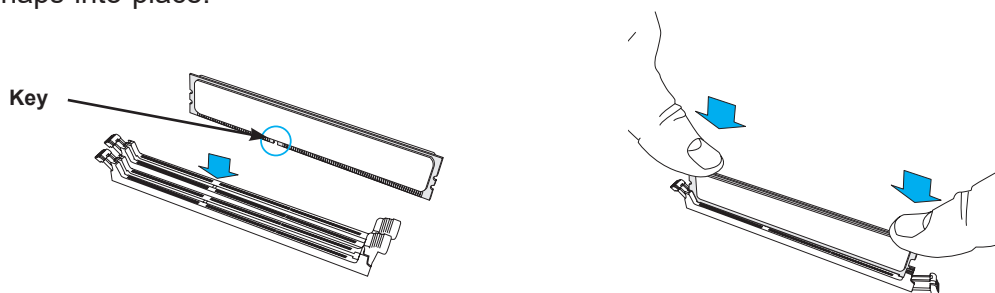

3. Press the release tabs to the locked position to secure the DIMM module into the slot.

Caution: Exercise extreme caution when installing or removing memory modules to prevent damage to the DIMMs or slots.

Removing Memory

To remove a DIMM, unlock the release tabs then pull the DIMM from the memory slot.

Motherboard Battery

The motherboard uses non-volatile memory to retain system information when system power is removed. This memory is powered by a lithium battery residing on the motherboard.

Replacing the Battery

Begin by removing power from the system as described in section 3.1.

1. Push aside the small clamp that covers the edge of the battery. When the battery is released, lift it out of the holder.
2. To insert a new battery, slide one edge under the lip of the holder with the positive (+) side facing up. Then push the other side down until the clamp snaps over it.

Note: Handle used batteries carefully. Do not damage the battery in any way; a damaged battery may release hazardous materials into the environment. Do not discard a used battery in the garbage or a public landfill. Please comply with the regulations set up by your local hazardous waste management agency to dispose of your used battery properly.

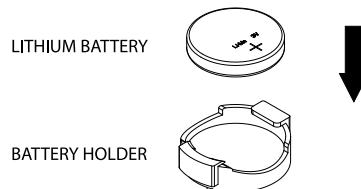

Figure 3-6. Installing the Onboard Battery

Warning: There is a danger of explosion if the onboard battery is installed upside down (which reverses its polarities). This battery must be replaced only with the same or an equivalent type recommended by the manufacturer (BR2032).

3.4 Chassis Components

This section provides instructions on installing and replacing system components. To assure compatibility, only use components that match the specifications or part numbers given.

Storage Drives

The system supports twenty-four hot-swap 2.5" storage drives. Each node controls:

- AS -2124BT-HTR – Six SATA drives
- AS -2124BT-HNTR – Four NVMe/SATA and two SATA drives

Note: Enterprise level hard disk drives are recommended for use in Supermicro chassis and servers. For information on recommended HDDs, visit the Supermicro website at www.supermicro.com/aplus.

Drive Carriers

The drives are mounted in drive carriers that simplify their removal from the chassis. These carriers also help promote proper airflow. Even carriers without drives must remain in the chassis for proper airflow.

Each drive carrier has two LED indicators: an activity indicator and a status indicator. The status indicator remains off.

Drive Carrier LED Indicators			
	Color	Blinking Pattern	Behavior for Device
Activity LED	Blue	Solid On	Drive installed
	Blue	Blinking	I/O activity

Drive Configuration

The chassis contains four separate computing node drawers, each with its own motherboard. Each node controls a set of six drives. If a node drawer is pulled out of the chassis, the drives associated with that node will power down.

Node B controls drives B1, B2, B3, B4, B5 and B6	Node D controls drives D1, D2, D3, D4, D5 and D6
Node A controls drives A1, A2, A3, A4, A5 and A6	Node C controls drives C1, C2, C3, C4, C5 and C6

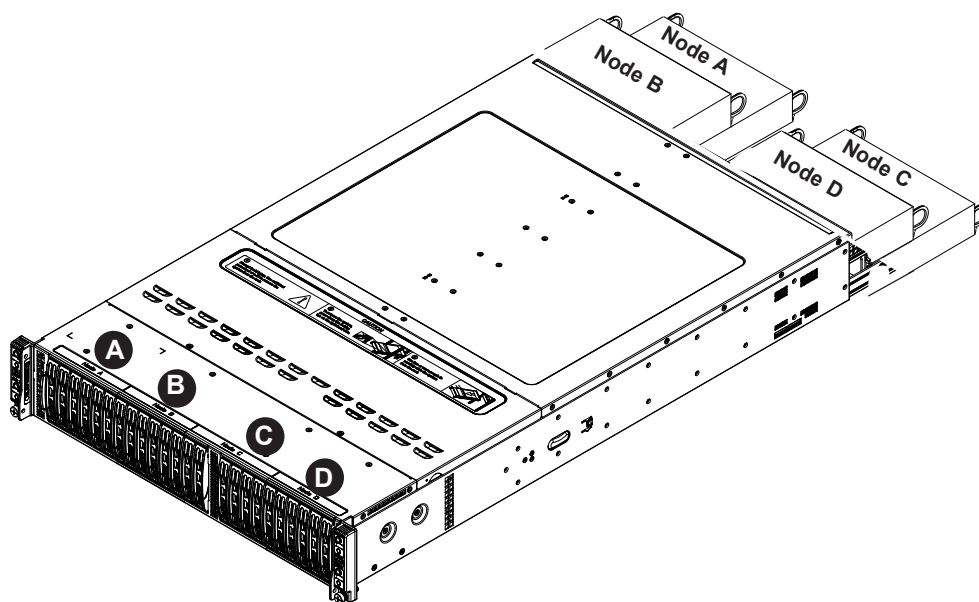

Figure 3-7. Storage Drives and the Corresponding Nodes

Installing Drives

Removing Drive Carriers from the Chassis

1. Press the release button on the drive carrier. This extends the drive carrier handle.
2. Use the handle to pull the carrier out of the chassis (Figure 3-5).
3. Remove the dummy drive from the carrier (Figure 3-6).

Caution: Except for short periods of time (swapping drives), do not operate the server with the drive carriers removed from the bays, regardless of how many drives are installed, for proper airflow.

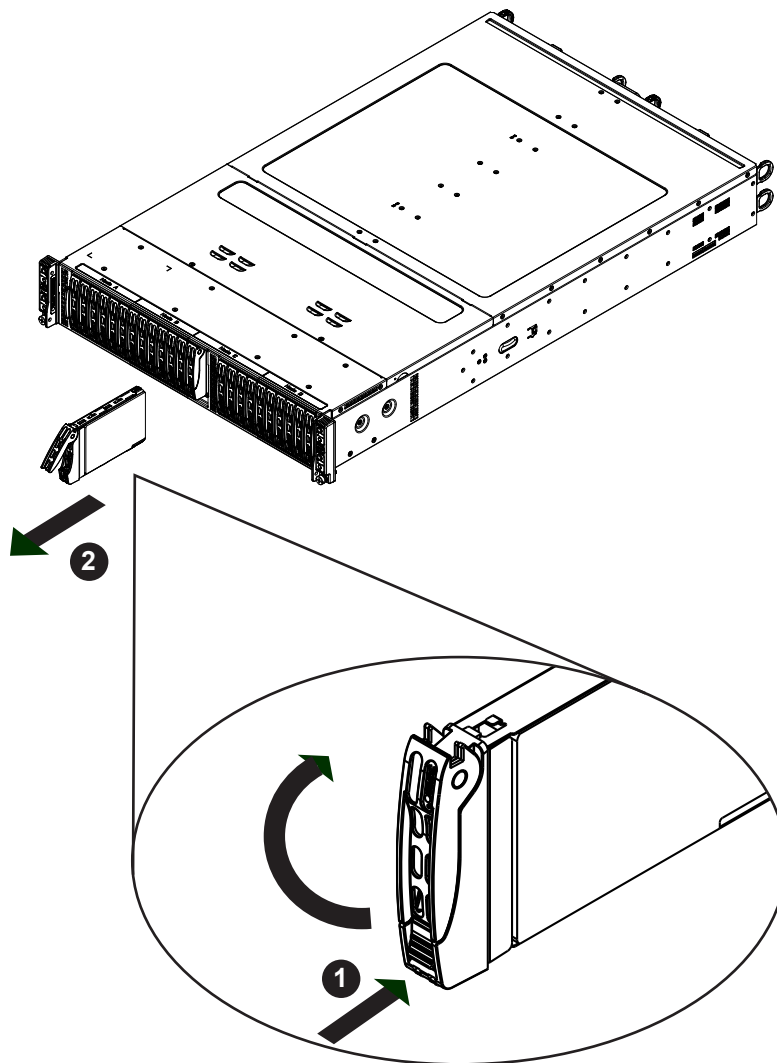

Figure 3-8. Removing a Drive Carrier

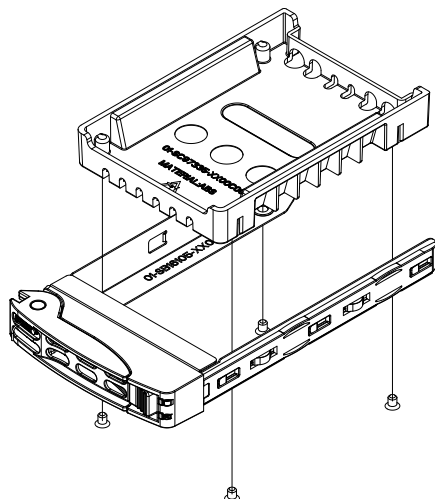

Figure 3-9. Removing a Dummy Drive from the Drive Carrier

Installing a Drive

1. Install a new drive into the carrier with the printed circuit board side facing down so that the mounting holes in the drive align with those in the carrier.
2. Secure the hard drive into the carrier with the screws.

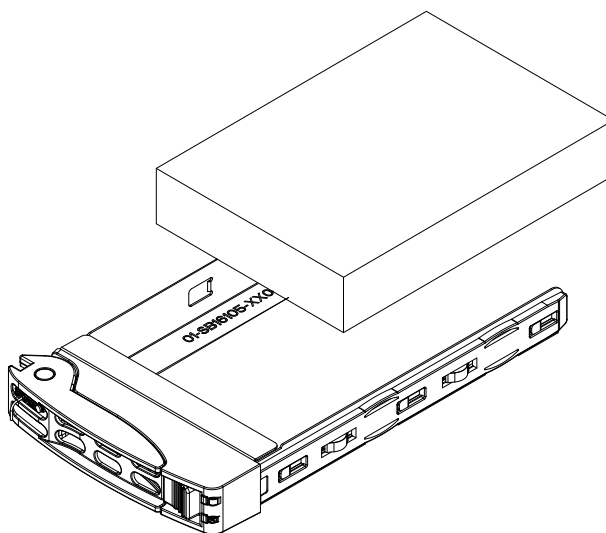

Figure 3-10. Installing the Hard Drive

3. Insert the drive and carrier into its bay vertically, keeping the carrier oriented so that the release button is on the bottom. When the carrier reaches the rear of the bay, the release handle starts to retract.
4. Push the upper part of the drive carrier handle until it clicks into the locked position.

Installing an M.2 Solid State Drive

The motherboard can accommodate an M.2 solid state drive (SSD). The M.2 socket supports PCIe 3.0 x4 (32 Gb/s) SSD cards in the 2280 or 22110 form factors. For the 22110 form factor, the appropriate standoff comes pre-installed on the motherboard. To install a 2280 device, the standoff must be moved.

Caution: Use industry-standard anti-static equipment, such as gloves or wrist strap, and follow precautions to avoid damage caused by ESD.

Note: M.2 for should be used for operating systems only. It is not designed for read/write intensive applications. Also, there are some thermal limitations. Please contact Supermicro Support before installing an M.2 device.

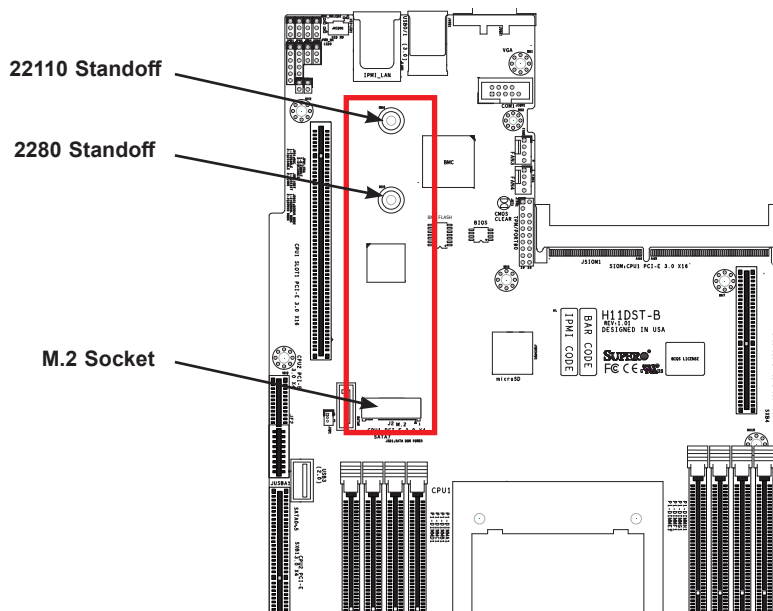

Figure 3-11. Position of M.2 Socket and Standoffs

Installing the M.2 SSD

1. Remove the node from the chassis, exposing the motherboard.
2. Check that the plastic standoff is in the correct position for your SSD. If not, gently pull the entire plastic standoff from the motherboard and insert it in the correct hole.
3. Insert the SSD into the socket (J2) on the motherboard, then push it flat against the plastic standoff.
4. Secure the SSD by firmly inserting the standoff plug.
5. Replace the node into the chassis.

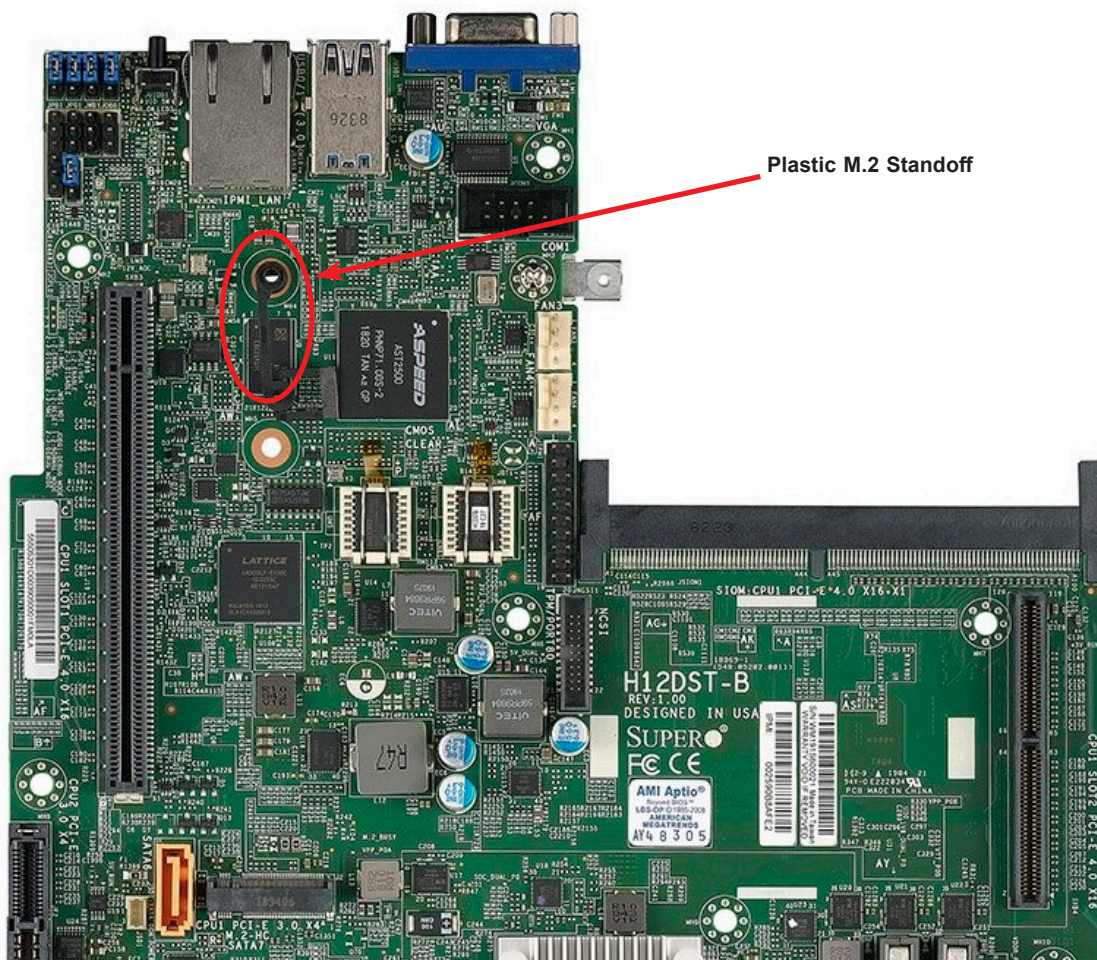

Figure 3-12. The Plastic Standoff
(in the hole for 22110 SSD)

Installing Expansion Cards

The system can accommodate two low-profile PCIe 4.0 x16 cards per node, for a total of eight in the chassis.

Installing an Expansion Card

1. Power down the node and remove it from the chassis.
2. Remove the screws holding the riser card brackets.
 - For the right side (looking from the node rear), remove the three screws on the right.
 - For the left side, remove the three screws on the left.
3. Remove the blank PCI shield from the bracket.
4. Slide the expansion card bracket into the open PCI slot while plugging the expansion card into the riser card.
5. Secure the expansion card bracket into the PCI slot with a screw.
6. Replace the riser card brackets and secure with the screws.

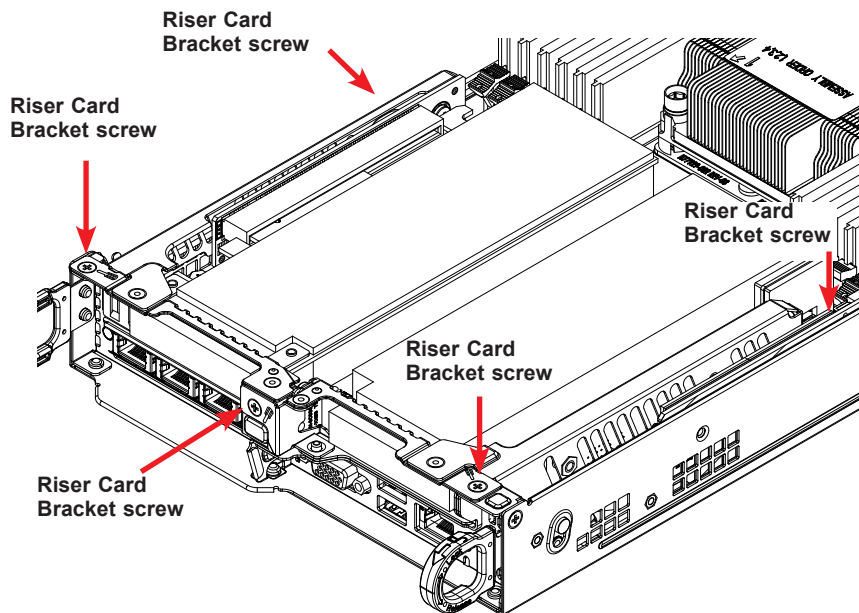

Figure 3-13. Installing the Expansion Card

SIOM Card

The Supermicro Input/Output module (SIOM) card provides options for network connection. It is inserted into a SIOM slot on the motherboard. This installation is usually performed by a system integrator or manufacturer.

Installing the SIOM Card

Before installing the motherboard into the node drawer:

1. Insert the SIOM card into the motherboard as shown.
2. Secure it with a screw. **Note:** Torque range is 0.20-0.28 Nm.
3. Install the covering bracket on the rear of the node drawer.
4. Install the motherboard including the other screw on the SIOM card.

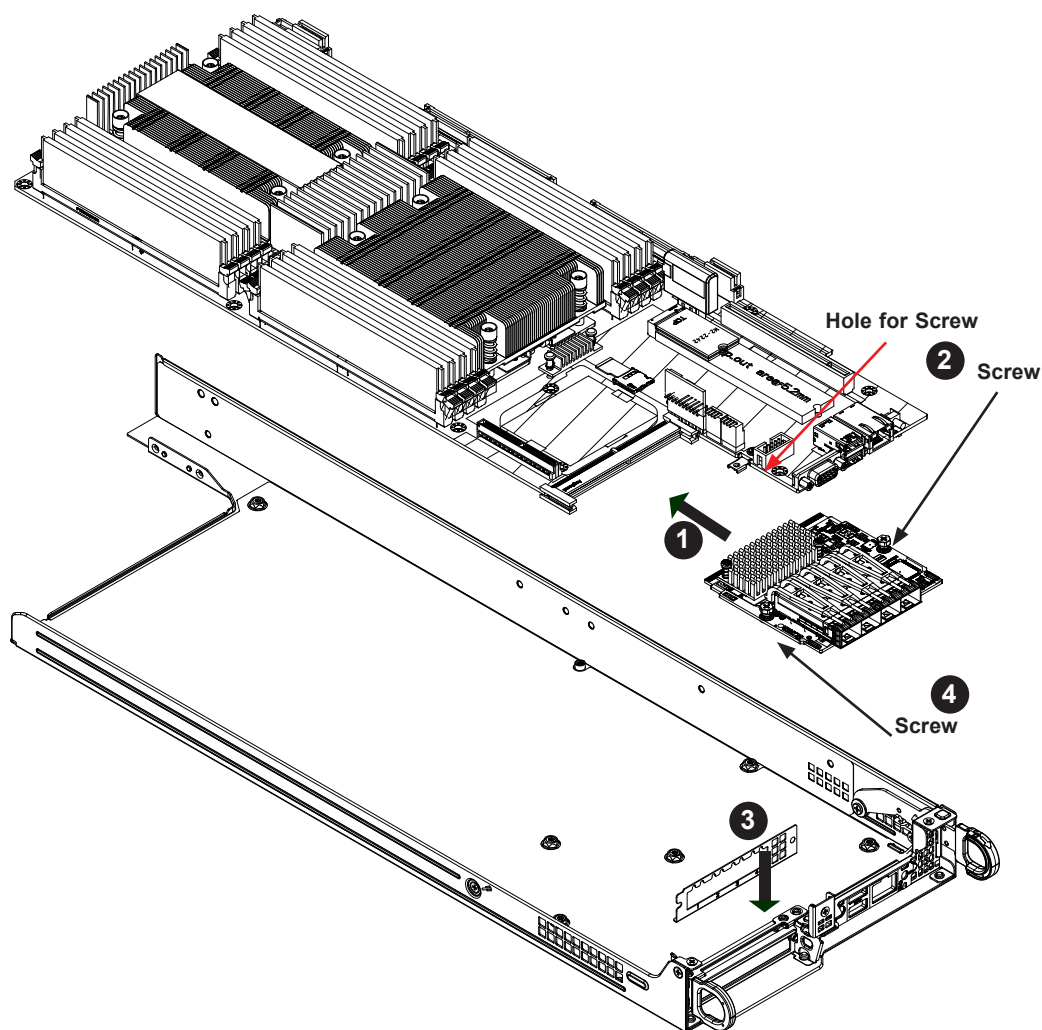

Figure 3-14. SIOM Card Position on Node Drawer Rear

Note: Graphics in this manual are for illustration. Your components may look slightly different.

System Fans

Four mid-chassis fans provide cooling.

Fan speed is controlled by a system temperature setting in IPMI. If a fan fails, the remaining fans will ramp up to full speed. The system can continue to run with a failed fan. Replace any failed fan at your earliest convenience with the same type and model.

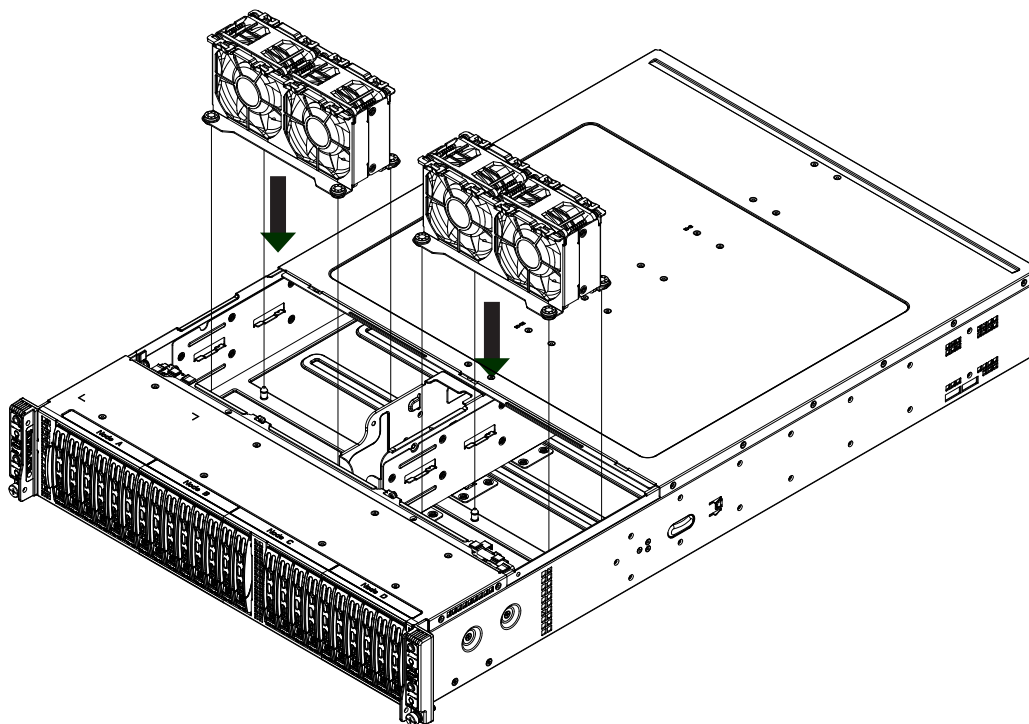

Figure 3-15. System Fan Placement

Changing a System Fan

1. Determine which fan is failing. If possible, use IPMI. If not, remove the chassis cover while the power is on, and examine the fans to determine which one has failed.
2. Power down the associated node as described in Section 3.1.
3. Remove the failed fan's power cable from the backplane.
4. Lift the fan housing up and out of the chassis.
5. Push the fan up from the bottom and out of the top of the housing.
6. Replace it with the same model fan, return the housing to the chassis, connect the power cable, and power on.

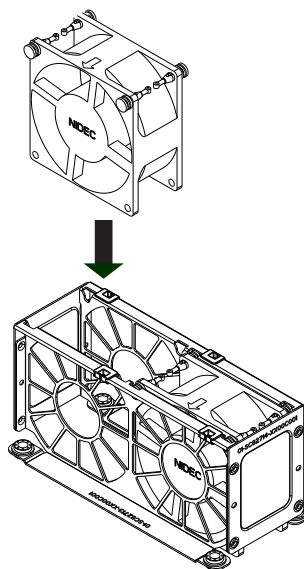

Figure 3-16. Fan into Housing

Checking the Server Air Flow

- Make sure there are no objects to obstruct airflow in and out of the server.
- Do not operate the server without drives or drive carriers in the drive bays.
- Use only recommended server parts.
- Make sure no wires or foreign objects obstruct air flow through the chassis. Pull all excess cabling out of the airflow path or use shorter cables.

The control panel LEDs display system heat status. See “Control Panel” in Chapter 1 for details.

Overheating

There are several possible responses if the system overheats.

- Use the LEDs to determine the nature of the overheating condition.
- Confirm that the chassis covers are installed properly.
- Make sure all fans are present and operating normally.
- Check the routing of the cables.
- Verify that the heatsinks are installed properly.

Power Supply

The chassis features redundant power supplies. The power modules can be changed without powering down the system. New units can be ordered directly from Supermicro or authorized distributors.

These power supplies are auto-switching capable. This feature enables them to automatically sense the input voltage and operate at a 100-120v or 180-240v. An amber light will be illuminated on the power supply when the power is off. An illuminated green light indicates that the power supply is operating.

Replacing the Power Supply

1. Unplug the AC cord from the module to be replaced.
2. Push the release tab on the back of the power supply as illustrated.

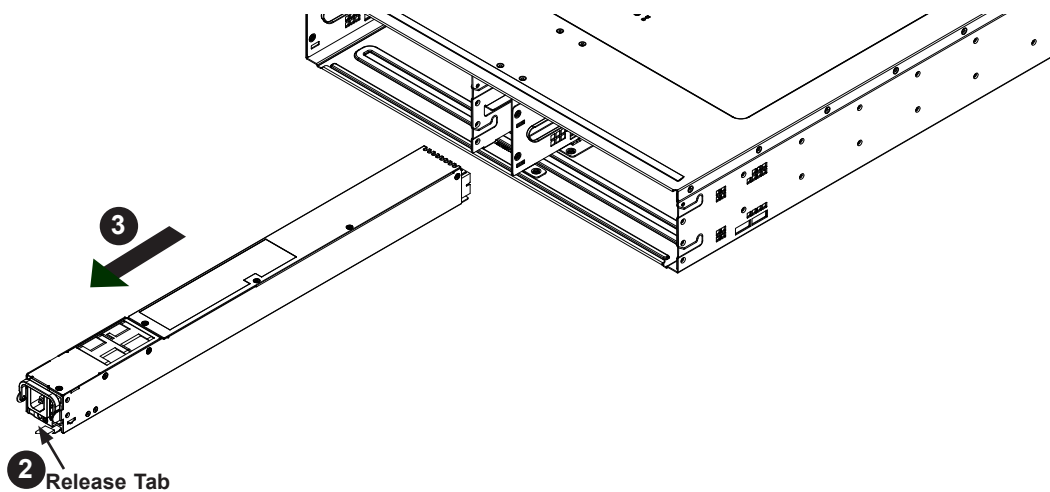

Figure 3-17. Power Supply Release Tab

3. Pull the power supply out using the handle provided.
4. Replace the failed power module with the same model.
5. Push the new power supply module into the power bay until it clicks.
6. Plug the AC power cord back into the module.

Chapter 4

Motherboard Connections

This section describes the connections, jumpers and LED indicators on the motherboard and provides pinout definitions. Not all connections are required. A motherboard layout indicating component locations may be found in Chapter 1.

Please review the Safety Precautions in Chapter 3 before installing or removing components.

4.1 Headers and Connectors

The data cables in the system have been carefully routed to maintain airflow efficiency. If you disconnect any of these cables, take care to re-route them as they were originally.

Important! Make sure the the cables do not come into contact with the fans.

Fan Headers

There are two fan headers on the motherboard. These are 4-pin fan headers; pins 1-3 are backward compatible with traditional 3-pin fans. The onboard fan speeds are controlled by Thermal Management through the BIOS > Hardware Monitoring. **Note:** When using Thermal Management setting, use all 3-pin fans or all 4-pin fans.

Fan Header Pin Definitions	
Pin#	Definition
1	Ground (Black)
2	+12V (Red)
3	Tachometer
4	PWM Control

Disk-On-Module Power Connector

The Disk-On-Module (DOM) power connector at JSD1 provides 5V power to a solid-state DOM storage device connected to one of the SATA ports.

DOM Power Pin Definitions	
Pin#	Definition
1	5V
2	Ground
3	Ground

TPM Header/Port 80 Connector

The JTPM1 header is used to connect a Trusted Platform Module (TPM), which is available from Supermicro. A TPM is a security device that supports encryption and authentication in hard drives. It enables the motherboard to deny access if the TPM associated with the hard drive is not installed in the system.

For more information on TPM: <http://www.supermicro.com/manuals/other/TPM.pdf>.

Trusted Platform Module Header Pin Definitions			
Pin#	Definition	Pin#	Definition
1	LCLK	2	GND
3	LFRAME#	4	No Pin
5	LRESET#	6	NC
7	LAD3	8	LAD2
9	3.3V	10	LAD1
11	LAD0	12	GND
13	SMB_CLK4 (X)	14	SMB_DAT4 (X)
15	P3V3_STBY	16	SERIRQ
17	GND	18	LP_CLKRUN_L
19	P3V3_STBY	20	LDRQ0_L

PCIe M.2 Connector

The PCIe M.2 (J2) connector is for devices such as memory cards, wireless adapters, etc. These devices must conform to the PCIe M.2 specifications (formerly known as NGFF). This particular PCIe M.2 supports M-Key (PCIe x4 or SATA) storage card.

USB 3

The internal USB3 (USB 2.0) type A connector provides an internal access port with extensive USB devices, which including the keyboard, mouse, as well as the USB DOM.

SATA Ports

The H12DST-B has six (6) available SATA 3.0 ports (SATA0~5) via a riser card supported by CPU1. The yellow SATA6 connector supports Super-DOM with +5V power integrated in the SATA connector.

Front Control Panel Connector

JF1 contains various buttons and indicators that are normally located on a control panel at the front of the chassis.

4.2 Ports

See the figure below for the locations and descriptions of the various I/O ports on the rear of the motherboard.

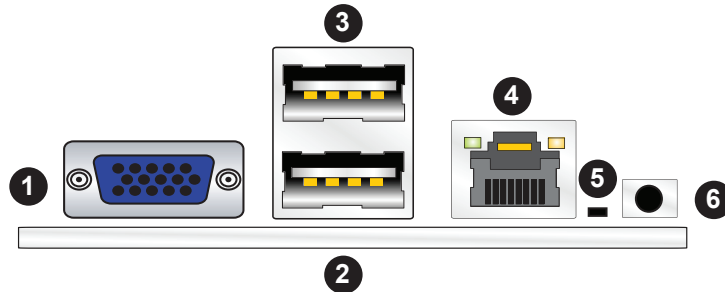

Figure 4-2. Rear I/O Ports

Rear I/O Ports					
#	Description	#	Description	#	Description
1.	VGA Port	3.	USB 1 (3.0)	5.	UID LED
2.	USB 0 (3.0)	4.	IPMI LAN Port	6.	UID Switch

Universal Serial Bus (USB) Ports

There are two Universal Serial Bus ports located on the rear I/O panel and an additional two USB headers and a USB Type A header on the motherboard. These can be used to provide front USB access (cables not included).

Unit Identifier Switch/UID LED Indicator

A rear Unit Identifier (UID) switch and LED indicator are located on the rear side of the system. When you press the UID switch, both front and rear UID LED indicators are illuminated. Press the UID switch again to turn off the LEDs. The UID indicators provide easy identification of a system among a rack of many.

Note: UID can also be triggered using IPMI.

LAN Ports

There are LAN ports on the chassis rear provided by the SIOM card. There is also a dedicated IPMI LAN port on the I/O back panel. For more information on IPMI, refer to the IPMI User's Guide posted on our website at <http://www.supermicro.com>.

4.3 Jumpers

Explanation of Jumpers

To modify the operation of the motherboard, jumpers are used to choose between optional settings. Jumpers create shorts between two pins to change the function associated with it. Pin 1 is identified with a square solder pad on the printed circuit board. See the motherboard layout page for jumper locations.

Note: On a two-pin jumper, "Closed" means the jumper is on both pins and "Open" indicates the jumper is either on only one pin or has been completely removed.

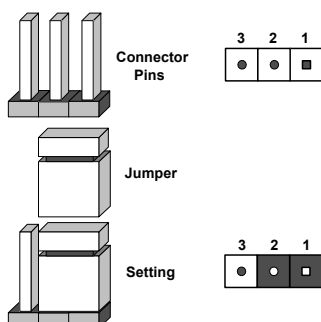

CMOS Clear

JBT1 is used to clear CMOS, which will also clear any passwords. Instead of pins, this jumper consists of contact pads to prevent accidentally clearing the contents of CMOS.

To Clear CMOS

1. First power down the system and unplug the power cord(s).
2. Remove the cover of the chassis to access the motherboard.
3. Remove the onboard battery from the motherboard.
4. Short the CMOS pads with a metal object such as a small screwdriver for at least four seconds.
5. Remove the screwdriver (or shorting device).
6. Replace the cover, reconnect the power cord(s) and power on the system.

Notes: Clearing CMOS will also clear all passwords.

Do not use the PW_ON connector to clear CMOS.



JBT1 contact pads

Watch Dog

JWD1 controls the Watch Dog function. Watch Dog is a monitor that can reboot the system when a software application hangs. Jumping pins 1-2 will cause Watch Dog to reset the system if an application hangs. Jumping pins 2-3 will generate a non-maskable interrupt signal for the application that hangs. Watch Dog must also be enabled in BIOS.

The default setting is Reset.

Note: When Watch Dog is enabled, the user must to write their own application software to disable it.

Watch Dog Jumper Settings	
Jumper Setting	Definition
Pins 1-2	Reset
Pins 2-3	NMI
Open	Disabled

Debug Mode Enable/Disable

Jumper JDBG1 will enable or disable Debug Mode on the motherboard. See the table below for jumper settings. The default setting is Normal Mode.

Debug Mode Enable/Disable Jumper Settings (JDBG1)	
Jumper Setting	Definition
Pins 1-2	Normal Mode (default)
Pins 2-3	Debug Mode

4.4 LED Indicators

IPMI LAN LED

The yellow LED indicates activity, while the Link LED indicates the speed of the connection.

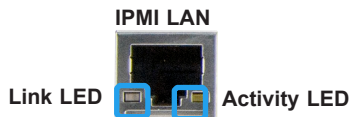

IPMI LAN LED Link LED (left)	
LED Color	Definition
None	10 Mb/s
Green	100 Mb/s
Amber	1 Gb/s

Onboard Power LED

PWR_OK LED3 is an Onboard Power LED. When this LED is illuminated, it means power is present on the motherboard. In suspend mode this LED will blink on and off.

BMC Heartbeat LED

A BMC Heartbeat LED (BMC_HB LED2) blinks to indicate BMC is functioning normally.

BMC Heartbeat LED State		
Color	State	Definition
Green	Solid On	BMC is not ready
Green	Blinking	BMC Normal
Green	Fast Blinking	BMC: Initializing

4.5 PCIe Express Slots

PCIe Express 4.0 x16

There are two PCIe 4.0 x16 slots on the motherboard. Slot 1 and Slot 2 are supported by CPU1 through the riser cards. Refer to the layout on Section 1.1 for their location.

PCIe Express 3.0 x4

There are two PCIe 3.0 x4 slots supported by CPU2. They are located at JF2 and SXB1. SXB1 is also used for SATA0~5. Refer to the layout on Section 1.1 for their location.

PCIe Express 4.0 x24

A PCIe 4.0 x24 slot supported by CPU2 is located at SXB2. Refer to the layout on Section 1.1 for the location.

Powered SATA DOM (SuperDOM)

A SATA DOM (Device-on-Disk) is located at SATA6 on the motherboard. SATA6 is used with a Supermicro SuperDOM, which is a yellow SATA DOM connector with a power pin built in, and no external power supply is needed. Supermicro SuperDOM is backward-compatible with a regular SATA HDD or SATA DOM that requires an external power supply.

SIOM Networking Slot

There is one SIOM (Super I/O Module) networking slot (PCIe 4.0 x16+1) on the motherboard. See the layout on Section 1.1 for the location.

Chapter 5

Software

After the hardware has been installed, you can install the Operating System (OS) and install the drivers.

5.1 Microsoft Windows OS Installation

Installing the OS

1. Create a method to access the MS Windows installation ISO file. That might be a DVD, perhaps using an external USB/SATA DVD drive, or a USB flash drive, or the IPMI KVM console.
2. Go to the Supermicro web page for your motherboard and click on "Download the Latest Drivers and Utilities", select the proper driver, and copy it to a USB flash drive.
3. Boot from a bootable device with Windows OS installation. You can see a bootable device list by pressing **F11** during the system startup.

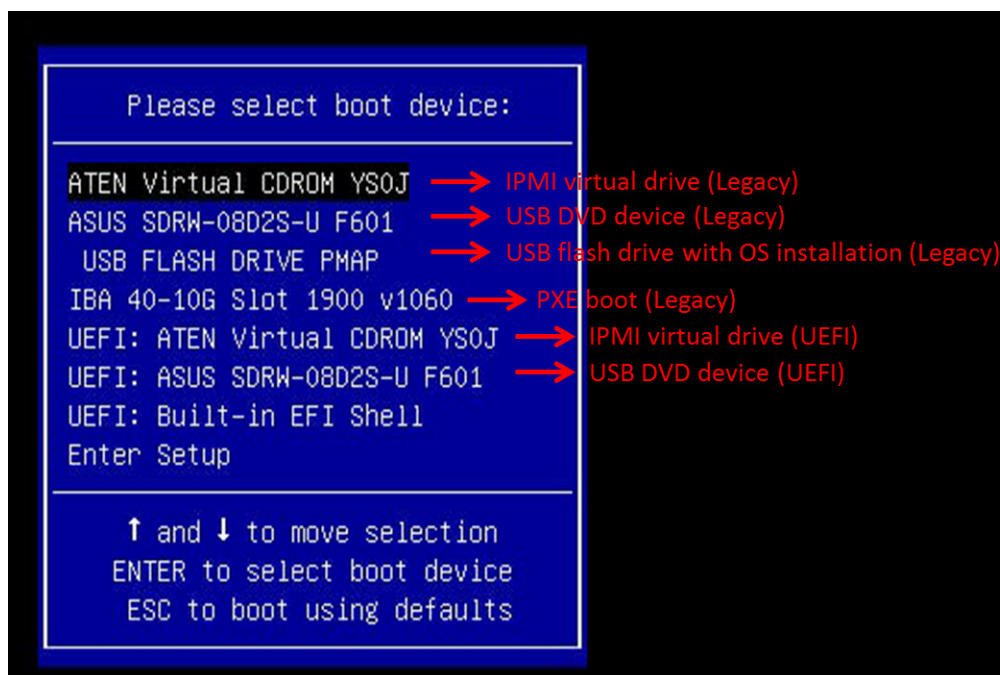

Figure 5-1. Select Boot Device

4. During Windows Setup, continue to the dialog where you select the drives on which to install Windows. If the disk you want to use is not listed, click on “Load driver” link at the bottom left corner.

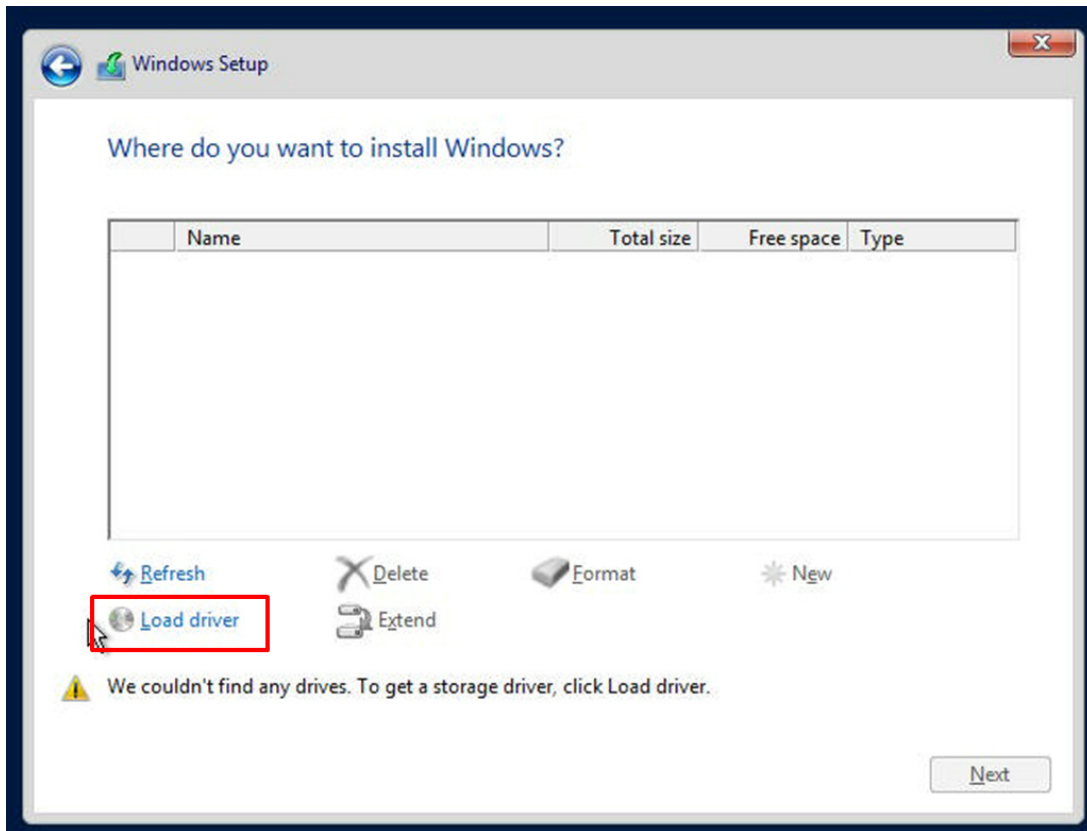

Figure 5-2. Load Driver Link

To load the driver, browse the USB flash drive for the proper driver files.

- Choose the SATA/sATA AHCI driver indicated then choose the storage drive on which you want to install it.
5. Once all devices are specified, continue with the installation.
 6. After the Windows OS installation has completed, the system will automatically reboot multiple times.

5.2 Driver Installation

The Supermicro website contains drivers and utilities for your system at www.supermicro.com/wdl/driver/AMD/SP3. Some of these must be installed, such as the chipset driver.

After accessing the website, go into the CDR_Images (in the parent directory of the above link) and locate the ISO file for your motherboard. Download this file to a USB flash drive or a DVD. (You may also use a utility to extract the ISO file if preferred.)

Another option is to go to the Supermicro website at <http://www.supermicro.com/products/>. Find the product page for your motherboard, and "Download the Latest Drivers and Utilities".

Insert the flash drive or disk and the screenshot shown below should appear.

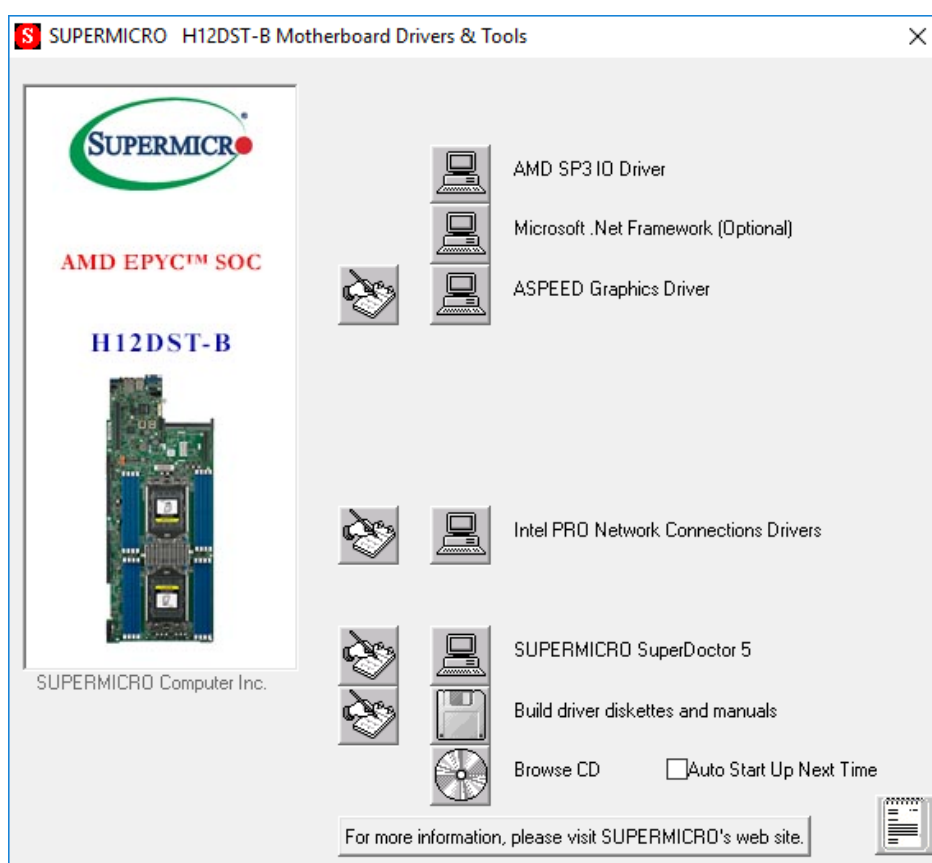

Figure 5-3. Driver & Tool Installation Screen

Note: Click the icons showing a hand writing on paper to view the readme files for each item. Click the computer icons to the right of these items to install each item (from top to the bottom) one at a time. **After installing each item, you must re-boot the system before moving on to the next item on the list.** The bottom icon with a CD on it allows you to view the entire contents.

5.3 SuperDoctor® 5

The Supermicro SuperDoctor 5 is a program that functions in a command-line or web-based interface for Windows and Linux operating systems. The program monitors such system health information as CPU temperature, system voltages, system power consumption, fan speed, and provides alerts via email or Simple Network Management Protocol (SNMP).

SuperDoctor 5 comes in local and remote management versions and can be used with Nagios to maximize your system monitoring needs. With SuperDoctor 5 Management Server (SSM Server), you can remotely control power on/off and reset chassis intrusion for multiple systems with SuperDoctor 5 or IPMI. SuperDoctor 5 Management Server monitors HTTP, FTP, and SMTP services to optimize the efficiency of your operation.

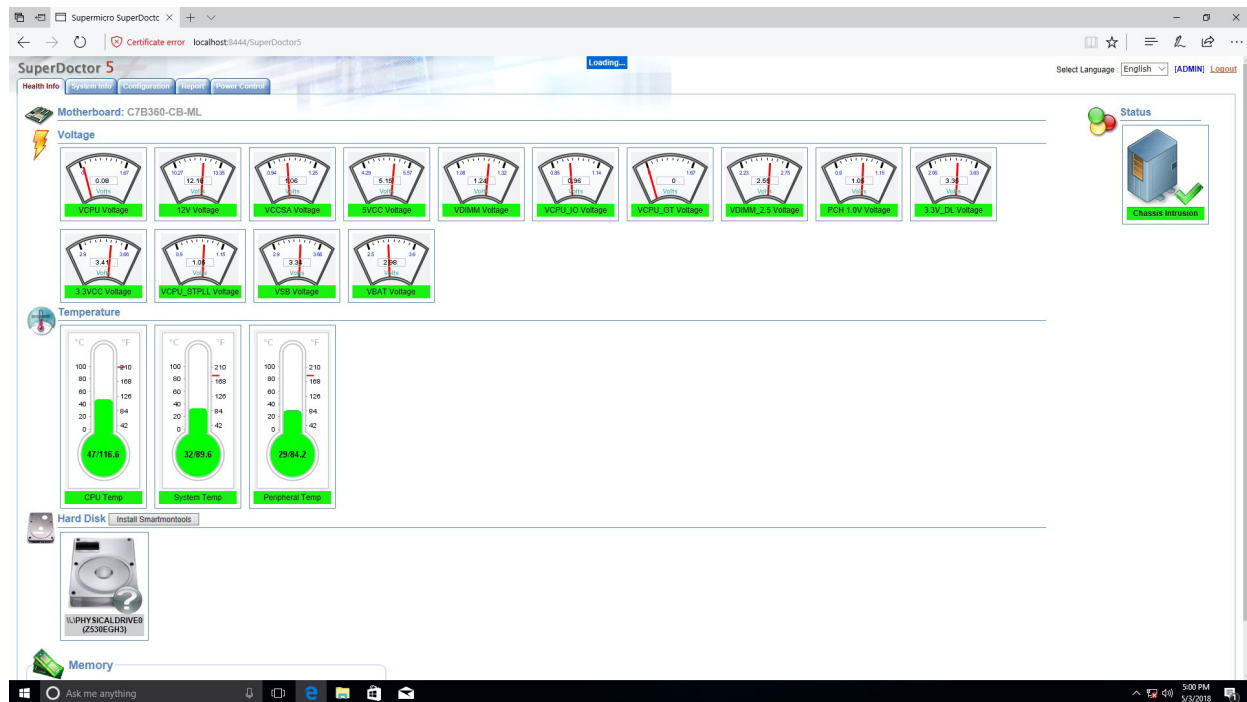

Figure 5-4. SuperDoctor 5 Interface Display Screen (Health Information)

5.4 BMC

The motherboard provides remote access, monitoring and management through the baseboard management controller (BMC) and other management controllers distributed among different system modules. There are several BIOS settings that are related to BMC. For general documentation and information on BMC, visit our website at:

www.supermicro.com/en/solutions/management-software/bmc-resources

BMC ADMIN User Password

For security, each system is assigned a unique default BMC password for the ADMIN user. This can be found on a sticker on the chassis and a sticker on the motherboard. The sticker also displays the BMC MAC address.



Figure 5-5. BMC Password Label

Chapter 6

BIOS

6.1 Introduction

This chapter describes the AMI BIOS setup utility for the H12DST-B and provides the instructions on navigating the setup screens. The BIOS is stored in a Flash EEPROM and can be updated.

Note: Due to periodic changes to the BIOS, some settings may have been added or deleted since this manual was published.

Starting BIOS Setup Utility

To enter the AMI BIOS setup utility screens, press the <Delete> key while the system is booting up. (There are a few cases when other keys are used, such as <F1>, <F2>, etc.)

The BIOS screens have three main frames. The large left frame displays options can be configured by the user. These are blue. When an option is selected, it is highlighted in white. Settings printed in **Bold** are the default values.

In the left frame, a " ►" indicates a submenu. Highlighting such an item and pressing the <Enter> key opens the list of settings in that submenu.

The upper right frame displays helpful information for the user. The AMI BIOS has default informational messages built in. The manufacturer retains the option to include, omit, or change any of these informational messages.

The lower right frame lists navigational methods. The AMI BIOS setup utility uses a key-based navigation system called *hot keys*. Most of these hot keys can be used at any time during setup navigation. These keys include <F3>, <F4>, <Enter>, <ESC>, arrow keys, etc.

Some system parameters may be changed.

6.2 Main Setup

When running the AMI BIOS setup utility, it starts with the Main screen. You can always return to it by selecting the Main tab on the top of the screen.

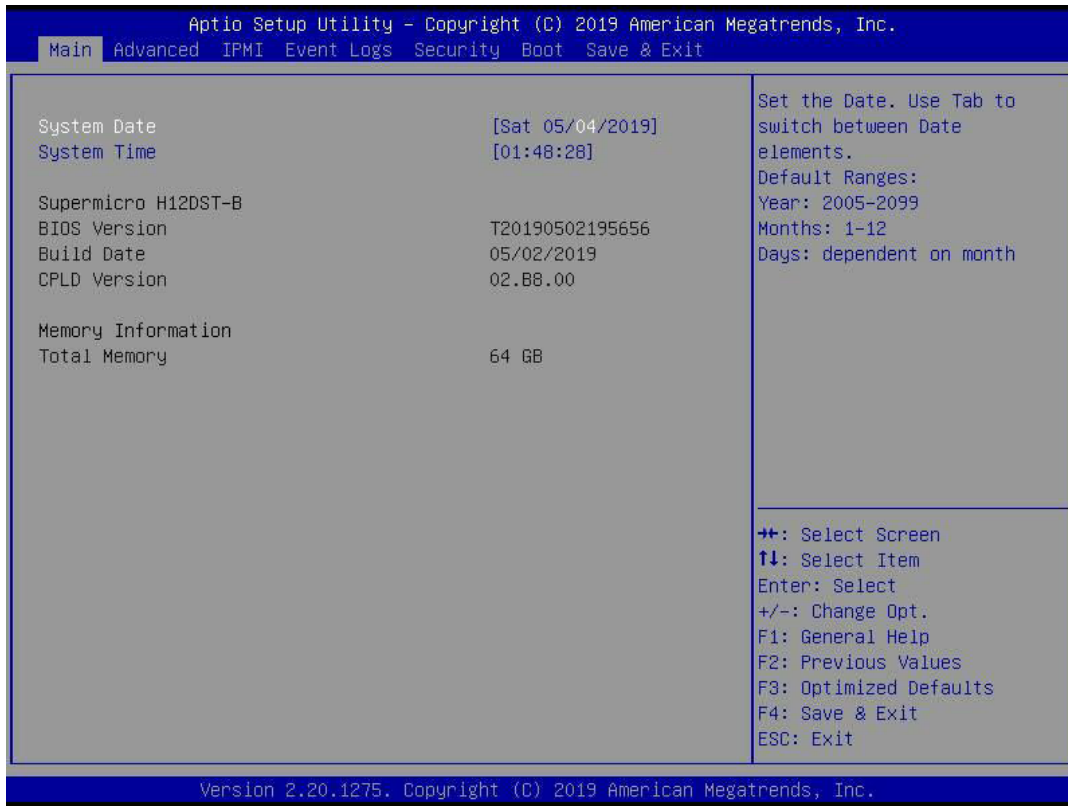

The Main tab page allows you to set the date and time, and it displays system information.

System Date/System Time

Use this option to change the system date and time. Highlight *System Date* or *System Time* using the arrow keys. Enter new values using the keyboard. Press the <Tab> key or the arrow keys to move between fields. The date must be entered in MM/DD/YYYY format. The time is entered in HH:MM:SS format.

Note: The time is in the 24-hour format. For example, 5:30 P.M. appears as 17:30:00. The date's default value is 01/01/2016 after RTC reset.

Supermicro H12DST-B (Motherboard model)

BIOS Version

Build Date (of the BIOS)

CPLD (Complex Programmable Logic Device) Version: This item displays the CPLD version used in the system.

Memory Information

Total Memory (for the system)

Memory Speed

6.3 Advanced Setup Configurations

Use the arrow keys to select the Advanced tab and press <Enter> to access the submenu items.

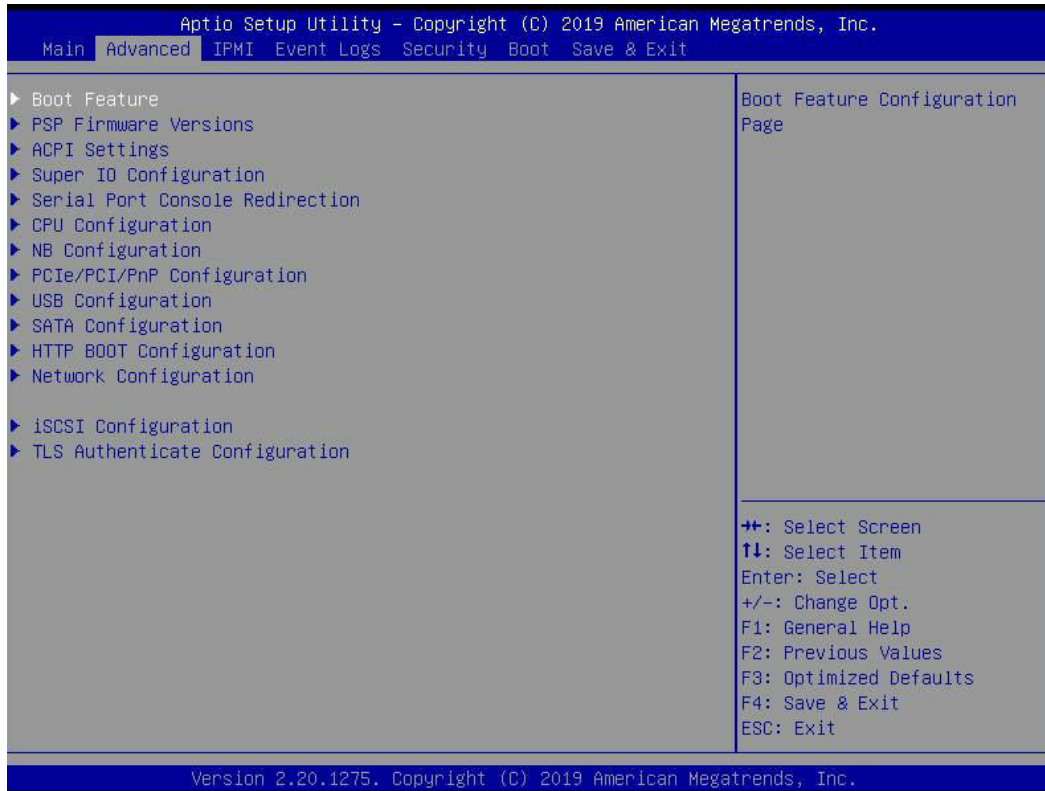

Caution: Take caution when changing the Advanced settings. An incorrect value, a very high DRAM frequency, or an incorrect DRAM timing setting may make the system unstable. If this occurs, revert to the manufacture default settings.

► Boot Feature

Quiet Boot

Use this feature to select the screen display between the POST messages and the OEM logo upon bootup. Select Disabled to display the POST messages. Select Enabled to display the OEM logo instead of the normal POST messages. The options are Disabled and **Enabled**.

Option ROM Messages

Use this feature to set the display mode for the Option ROM. Select Keep Current to display the current AddOn ROM setting. Select Force BIOS to use the Option ROM display set by the system BIOS. The options are **Force BIOS** and Keep Current.

Bootup NumLock State

Use this feature to set the Power on state for the <Numlock> key. The options are **On** and Off.

Wait For "F1" If Error

Use this feature to force the system to wait until the 'F1' key is pressed if an error occurs. The options are Disabled and **Enabled**.

INT19 (Interrupt 19) Trap Response

Interrupt 19 is the software interrupt that handles the boot disk function. When this item is set to Immediate, the ROM BIOS of the host adaptors will "capture" Interrupt 19 at bootup immediately and allow the drives that are attached to these host adaptors to function as bootable disks. If this item is set to Postponed, the ROM BIOS of the host adaptors will not capture Interrupt 19 immediately and allow the drives attached to these adaptors to function as bootable devices at bootup. The options are **Immediate** and Postponed.

Re-try Boot

If this item is enabled, the BIOS will automatically reboot the system from a specified boot device after its initial boot failure. The options are **Disabled**, Legacy Boot, and EFI Boot.

Power Configuration

Watch Dog Function

If enabled, the Watch Dog Timer will allow the system to reset or generate NMI based on jumper settings when it is expired for more than 5 minutes. The options are **Disabled** and Enabled.

Restore on AC Power Loss

Use this feature to set the power state after a power outage. Select Stay-Off for the system power to remain off after a power loss. Select Power-On for the system power to be turned on after a power loss. Select Last State to allow the system to resume its last power state before a power loss. The options are Stay Off, Power On, and **Last State**.

Power Button Function

This feature controls how the system shuts down when the power button is pressed. Select 4 Seconds Override for the user to power off the system after pressing and holding the power button for 4 seconds or longer. Select Instant Off to instantly power off the system as soon as the user presses the power button. The options are **Instant Off** and 4 Seconds Override.

►PSP Firmware Versions

This section displays the Platform Security Processor (PSP) firmware versions.

PSP Directory Level 1 (Fixed)

- PSP Recovery BL Ver
- SMU FW Version
- ABL Version
- APCB Version

- APOB Version
- APPB Version

PSP Directory Level 2 (Updateable)

- PSP Bootloader Version
- SMU FW Version
- ABL Version
- APCB Version
- APOB Version
- APPB Version

▶ACPI Settings

High Precision Event Timer

The High Precision Event Timer (HPET) can produce periodic interrupts and is used to synchronize multimedia streams, providing smooth playback and reducing the need to use other timestamp calculations. The options are Disabled and **Enabled**.

NUMA nodes per socket

This feature specifies the number of desired Non-Uniform Memory Access (NUMA) nodes per socket. Setting this to zero will attempt to interleave the two sockets together. The options are NPS0, NPS1, NPS2, NPS4 and **Auto**.

▶Super IO Configuration

The following Super IO information will display:

- Super IO Chip

▶Serial Port 1 Configuration

Serial Port

Select The options are Disabled and **Enabled**.

Device Settings

This item displays the status of a serial part specified by the user.

Change Settings

This feature specifies the base I/O port address and the Interrupt Request address of a serial port specified by the user. Select Auto to allow the BIOS to automatically assign the base I/O and IRQ address. The options are **Auto**, IO=3F8h; IRQ=4; IO=3F8h; IRQ=3,4,5,6,7,9,10,11,12; IO=2F8h; IRQ=3,4,5,6,7,9,10,11,12; IO=3E8h; IRQ=3,4,5,6,7,9,10,11,12; IO=2E8h; IRQ=3,4,5,6,7,9,10,11,12;

Sol Configurationf

Serial Port

The options are Disabled and **Enabled**.

Device Settings

Change Settings

The options are **Auto**, IO=2F8h; IRQ=3; IO=3F8h; IRQ=3,4,5,6,7,9,10,11,12; IO=2F8h; IRQ=3,4,5,6,7,9,10,11,12; IO=3E8h; IRQ=3,4,5,6,7,9,10,11,12; IO=2E8h; IRQ=3,4,5,6,7,9,10,11,12;

►Serial Port Console Redirection

COM1

Console Redirection

Select Enabled to enable console redirection support for a serial port specified by the user. The options are **Disabled** and Enabled.

****If the item above set to Enabled, the following items will become available for user's configuration:***

Console Redirection Settings

Terminal Type

This feature allows the user to select the target terminal emulation type for Console Redirection. Select VT100 to use the ASCII Character set. Select VT100+ to add color and function key support. Select ANSI to use the Extended ASCII Character Set. Select VT-UTF8 to use UTF8 encoding to map Unicode characters into one or more bytes. The options are VT100, **VT100+**, **VT-UTFB** and ANSI.

Bits per second

Use this feature to set the transmission speed for a serial port used in Console Redirection. Make sure that the same speed is used in the host computer and the client computer. A lower transmission speed may be required for long and busy lines. The options are 9600, 19200, 38400, 57600 and **115200** (bits per second).

Data Bits

Use this feature to set the data transmission size for Console Redirection. The options are 7 and **8**.

Parity

A parity bit can be sent along with regular data bits to detect data transmission errors. Select Even if the parity bit is set to 0, and the number of 1's in data bits is even. Select

Odd if the parity bit is set to 0, and the number of 1's in data bits is odd. Select None if you do not want to send a parity bit with your data bits in transmission. Select Mark to add a mark as a parity bit to be sent along with the data bits. Select Space to add a Space as a parity bit to be sent with your data bits. The options are **None**, Even, Odd, Mark and Space.

Stop Bits

A stop bit indicates the end of a serial data packet. Select 1 Stop Bit for standard serial data communication. Select 2 Stop Bits if slower devices are used. The options are **1** and **2**.

Flow Control

Use this feature to set the flow control for Console Redirection to prevent data loss caused by buffer overflow. Send a "Stop" signal to stop sending data when the receiving buffer is full. Send a "Start" signal to start sending data when the receiving buffer is empty. The options are **None** and Hardware RTS/CTS.

VT-UTFB Combo Key Support

Select Enabled to enable VT-UTF8 Combination Key support for ANSI/VT100 terminals. The options are Disabled and **Enabled**.

Recorder Mode

Select Enabled to capture the data displayed on a terminal and send it as text messages to a remote server. The options are **Disabled** and Enabled.

Resolution 100x31

Select Enabled for extended-terminal resolution support. The options are Disabled and **Enabled**.

Putty KeyPad

This feature selects the settings for Function Keys and KeyPad used for Putty, which is a terminal emulator designed for the Windows OS. The options are **VT100**, LINUX, XTERMR6, SC0, ESCN and VT400.

SOL

Console Redirection

Select Enabled to enable SOL console redirection support for a serial port specified by the user. The options are **Disabled** and Enabled.

****If the item above set to Enabled, the following items will become available for user's configuration:***

Console Redirection Settings

Terminal Type

This feature allows the user to select the target terminal emulation type for Console Redirection. Select VT100 to use the ASCII Character set. Select VT100+ to add color

and function key support. Select ANSI to use the Extended ASCII Character Set. Select VT-UTF8 to use UTF8 encoding to map Unicode characters into one or more bytes. The options are VT100, **VT100+**, **VT-UTFB** and ANSI.

Bits per second

Use this feature to set the transmission speed for a serial port used in Console Redirection. Make sure that the same speed is used in the host computer and the client computer. A lower transmission speed may be required for long and busy lines. The options are 9600, 19200, 38400, 57600 and **115200** (bits per second).

Data Bits

Use this feature to set the data transmission size for Console Redirection. The options are 7 and **8**.

Parity

A parity bit can be sent along with regular data bits to detect data transmission errors. Select Even if the parity bit is set to 0, and the number of 1's in data bits is even. Select Odd if the parity bit is set to 0, and the number of 1's in data bits is odd. Select None if you do not want to send a parity bit with your data bits in transmission. Select Mark to add a mark as a parity bit to be sent along with the data bits. Select Space to add a Space as a parity bit to be sent with your data bits. The options are **None**, Even, Odd, Mark and Space.

Stop Bits

A stop bit indicates the end of a serial data packet. Select 1 Stop Bit for standard serial data communication. Select 2 Stop Bits if slower devices are used. The options are **1** and **2**.

Flow Control

Use this feature to set the flow control for Console Redirection to prevent data loss caused by buffer overflow. Send a "Stop" signal to stop sending data when the receiving buffer is full. Send a "Start" signal to start sending data when the receiving buffer is empty. The options are **None** and Hardware RTS/CTS.

VT-UTFB Combo Key Support

Select Enabled to enable VT-UTF8 Combination Key support for ANSI/VT100 terminals. The options are Disabled and **Enabled**.

Recorder Mode

Select Enabled to capture the data displayed on a terminal and send it as text messages to a remote server. The options are **Disabled** and Enabled.

Resolution 100x31

Select Enabled for extended-terminal resolution support. The options are Disabled and **Enabled**.

Putty KeyPad

This feature selects the settings for Function Keys and KeyPad used for Putty, which is a terminal emulator designed for the Windows OS. The options are **VT100**, LINUX, XTERMR6, SC0, ESCN and VT400.

Legacy Console Redirection

Legacy Console Redirection Settings

Redirection COM Port

For this setting, select a COM port to display redirection of Legacy OS and Legacy OPROM messages. The options are **COM1** and SOL.

Resolution

For Legacy OS systems, use this setting to specify the number of Rows and Columns supported for redirection. The options are **80x24** and 80x25.

Redirect After POST

For this setting, when the Bootloader is selected, then the Legacy Console Redirection is disabled before booting to the legacy OS. If you select Always Enable, then the Legacy Console Redirection is enabled for legacy OS systems. The options are **Always Enable** and BootLoader.

Serial Port for Out-of-Band Management/Windows Emergency Management Services (EMS)

Console Redirection

Select Enabled to enable EMS console redirection support for a serial port specified by the user. The options are **Disabled** and Enabled.

**If the item above set to Enabled, the following items will become available for user's configuration:*

► Console Redirection Settings

Out-of-Band Mgmt Port

The feature selects a serial port in a client server to be used by the Microsoft Windows Emergency Management Services (EMS) to communicate with a remote host server. The options are **COM1**, COM2 (Disabled), and AMT SOL.

Terminal Type

Use this feature to select the target terminal emulation type for Console Redirection. Select VT100 to use the ASCII character set. Select VT100+ to add color and function key support. Select ANSI to use the extended ASCII character set. Select VT-UTF8 to use UTF8 encoding to map Unicode characters into one or more bytes. The options are VT100, VT100+, **VT-UTF8**, and ANSI.

Bits per Second

This item sets the transmission speed for a serial port used in Console Redirection. Make sure that the same speed is used in the host computer and the client computer. A lower transmission speed may be required for long and busy lines. The options are 9600, 19200, 57600, and **115200** (bits per second).

Flow Control

Use this item to set the flow control for Console Redirection to prevent data loss caused by buffer overflow. Send a "Stop" signal to stop sending data when the receiving buffer is full. Send a "Start" signal to start sending data when the receiving buffer is empty. The options are **None**, Hardware RTS/CTS, and Software Xon/Xoff.

Data Bits

Use this feature to set the data transmission size for Console Redirection. The options are 7 and **8**.

Parity

A parity bit can be sent along with regular data bits to detect data transmission errors. Select Even if the parity bit is set to 0, and the number of 1's in data bits is even. Select Odd if the parity bit is set to 0, and the number of 1's in data bits is odd. Select None if you do not want to send a parity bit with your data bits in transmission. Select Mark to add a mark as a parity bit to be sent along with the data bits. Select Space to add a Space as a parity bit to be sent with your data bits. The options are **None**, Even, Odd, Mark and Space.

Stop Bits

A stop bit indicates the end of a serial data packet. Select 1 Stop Bit for standard serial data communication. Select 2 Stop Bits if slower devices are used. The options are **1** and **2**.

► CPU Configuration**SMT Control**

Use this setting to specify Simultaneous Multithreading. Options include Disabled for 1T single thread and **Auto** for 2T two-thread if your system is capable of it.

Core Performance Boost

This setting is used to configure for Core Performance Boost. Options include Disabled and **Auto**.

Global C-state Control

This setting is used to configure for Global C-state Control. Options include Disabled, Enabled and **Auto**.

Core Control

This sets the number of cores to be used by your system. Once this option has been used to remove any cores, a power cycle is required in order for the future selections to take effect. Options include **Auto**, TWO (1+1), Four (2 + 2) and Six (3 + 3). If unsure, leave this to Auto.

L1 Stream HW Prefetcher / L2 Stream HW Prefetcher

This setting is used to enable or disable the L1/L2 Stream Hardware Prefetcher. The options are Disabled, Enabled and **Auto**.

SVM Mode

This setting enables or disables CPU Virtualization. The options are Disabled and **Enabled**.

SMEE

This setting enables or disables secure memory encryption control. The options are **Disabled** and Enabled.

► CPU1 Information

These sections are for informational purposes. They will display some details about the detected CPUs on the motherboard, such as:

- CPU Version
- Number of Cores Running
- Clock speed
- Processor Family
- Processor Model
- Microcode Patch Level
- L1 Instruction Cache (Size/Method)
- L1 Data Cache (Size/Method)
- L2 Cache (Size/Method)
- L3 Cache per Socket (Size/Method)

► NB Configuration

Determinism Slider

Use this setting to configure the Determinism Slider. Options include **Auto**, Power and Performance.

cTDP Control

Use this setting to configure the cTDP Control. Options include Manual and **Auto**.

IOMMU

Use this setting to enable/disable IOMMU. Options include **Disabled**, Enabled, and Auto.

ACS Enable

Use this setting to enable/disable ACS. Options include Enabled, Disabled and **Auto**.

►Memory Configuration

Memory Clock

This setting allows you to select different memory clock speed. The options include **Auto** and speed settings.

Memory Interleaving

This setting controls fabric level memory interleaving. Note that the channel, die and socket have requirements on memory populations and it will be ignored if the memory doesn't support the selected option. The options include Disabled and **Auto**.

Memory Interleaving Size

This setting controls the memory interleaving size. This determines the starting address of the interleave (bit 8, 9, 10 or 11). The options include 256 Bytes, 512 Bytes, 1 KB, 2 KB or **Auto**.

Chipselect Interleaving

This setting controls interleave memory blocks across the DRAM chip for node 0. The options are Disabled and **Auto**.

BankGroupSwap

This setting controls the Bank Group Swap. The options are Enabled, Disabled and **Auto**.

►CPU1 Memory Information

These sections are for informational purposes. They will display some details about the detected memory according to each CPU on the motherboard, such as:

- Detected Size (per slot, in MB)
- Current Speed (MT/s)

►PCIe/PCI/PnP Configuration

This menu provides PCIe/PCI/PnP configuration settings and information.

PCI Devices Common Settings

Above 4G Decoding

This setting enables or disables 64-bit capable devices ability to be decoded in above 4G address space (only if the system supports 64-bit PCI decoding). The options are Disabled and **Enabled**.

SR-IOV Support

If the system has SR-IOV capable PCI-E devices, this setting will enable or disable the Single Root IO Virtualization Support for the system. The options are **Disabled** and Enabled.

BME DMA Mitigation

Use this setting to re-enable the Bus Master Attribute that was disabled during PCI enumeration for PCI bridges after SMM is locked. The options are **Disabled** and Enabled.

ARI Forwarding

If supported by the hardware and set to 'enabled', the downstream port disables its traditional device number field, being 0 enforcement, when turning a type1 configuration request into a type0 configuration request. This permits access to extended functions in an ARI device immediately below the port. The options are **Disabled** and Enabled.

PCIe Spread Spectrum

Use this setting to enable or disable PCI-E Spread Spectrum for your system. The options are **Disabled** and Enabled.

Target Link Speed

If supported by hardware and set to Force to x.S GT/S (x being a value of 2.5, 5.0 or 8.0) for Downstream Ports, this sets an upper limit on Link Operational Speed by restricting the values advertised by the UPstream component in its training sequences. When **Auto** is selected, the HW initialized data will be used. The options are **Auto**, Force to 2.5 GT/s, Force to 5.0 GT/s, Force to 8.0 and Force to 16.0 GT/s.

VGA Priority

Use this setting to select between onboard or offboard VGA support. The options are **Onboard** and Offboard.

NVMe Firmware Source

Use this setting to select between the AMI Native firmware support or the device vendor-defined firmware support. The options are **Vendor Defined Firmware** and AMI Native Support.

M.2(AHCI) Firmware Source

Use this setting to select between the AMI Native firmware support or the device vendor-defined firmware support. The options are **Vendor Defined Firmware** and AMI Native Support.

RSC-PR-6-X2 SLOT1/SLOT2 PCI-E 4.0x16 OPROM

RSC-P-6-X2 SLOT1/SLOT2 PCI-E 4.0x16 OPROM

M.2 CPU1 PCI-E 3.0x4 OPROM

This setting enables or disables the listed PCI-E Slot OPROM option. The options are Disabled, **Legacy** or EFI.

Onboard LAN

Use this setting to enable or disable the onboard LAN feature. The options are **Enabled** and Disabled.

Onboard LAN1 Option ROM

Use this setting to select which option ROM is to be loaded for onboard LAN1 on the system. The options are Disabled, **Legacy** and EFI.

Onboard LAN2/LAN3 Option ROM

Use this setting to select which firmware function is to be loaded for onboard LAN2 on the system. The options are **Disabled** and PXE.

Onboard Video Option ROM

Use this setting to select which firmware function is to be loaded for onboard LAN2 on the system. The options are Disabled, **Legacy** and EFI.

► Network Stack Configuration

Network Stack

This setting allows you to enable or disable the UEFI Network Stack. The options are Disabled and **Enabled**.

IPv4 PXE Support

This setting allows you to enable or disable IPv4 PXE boot support. If disabled, IPv4 PXE boot support will not be available. The options are Disabled and **Enabled**.

IPv4 HTTP Support

This setting allows you to enable or disable IPv4 HTTP boot support. If disabled, IPv4 HTTP boot support will not be available. The options are **Disabled** and Enabled.

IPv6 PXE Support

This setting allows you to enable or disable IPv6 PXE boot support. If disabled, IPv6 PXE boot support will not be available. The options are Disabled and **Enabled**.

IPv6 HTTP Support

This setting allows you to enable or disable IPv6 HTTP boot support. If disabled, IPv6 HTTP boot support will not be available. The options are **Disabled** and Enabled.

PXE boot wait time

This setting allows you to set in a number field the wait time to press <ESC> to abort the PXE boot. Default is **0**.

Media detect count

This setting allows you set in a number field the number of times presence of media will be checked. Default is **1**.

►USB Configuration**Legacy USB Support**

Select Enabled to support onboard legacy USB devices. Select Auto to disable legacy support if there are no legacy USB devices present. Select Disable to have all USB devices available for EFI applications only. The options include **Enabled**, Disabled and Auto.

XHCI Hand-off

This is a work-around solution for operating systems that do not support XHCI (Extensible Host Controller Interface) hand-off. The XHCI ownership change should be claimed by the XHCI driver. The options include **Enabled** and Disabled.

USB Mass Storage Driver Support

This setting will enable or disable support for USB mass storage drivers. The options include Disabled and **Enabled**.

Port 60/64 Emulation

Select Enabled for I/O port 60h/64h emulation support, which in turn, will provide complete legacy USB keyboard support for the operating systems that do not support legacy USB devices. The options include Disabled and **Enabled**.

►SATA Configuration

This section displays the detected SATA devices installed on the system.

SATA Enable

This item enables or disables the onboard SATA controller supported by the Intel PCH chip. The options include Disabled, Enabled and **Auto**.

SATA Hotplug

This item enables or disables the onboard SATA controller's hot plug feature (PCH). The options include Disabled and **Enabled**.

SATA Information

This item displays information on the detected SATA devices connected and are detected.

▶ HTTP BOOT Configuration

HTTP Boot One Time

When the HTTP boot option is created, this option when enabled, will allow the system to boot via HTTP the first time and revert to the default boot after. The options include **Disabled** and **Enabled**.

Input the description

This option is an input field that, when the HTTP boot option is created, can be used to enter text to describe or identify the HTTP connection.

Boot URI

This option is an input field used to enter a web or network address to point to the HTTP boot files. This supports the HTTP or HTTPS protocols only.

▶ Network Configuration

**If EFI is selected in LAN OPROM after reboot, the following items will become available for configuration.*

▶ iSCSI Configuration

iSCSI Initiator Name

This feature allows the user to enter the unique name of the iSCSI Initiator in IQN format. Once the name of the iSCSI Initiator is entered into the system, configure the proper settings for the following items.

▶ Add an Attempt

▶ Delete Attempts

▶ Change Attempt Order

▶ TLS Authenticate Configuration

This submenu allows the user to configure Transport Layer Security (TLS) settings.

▶ Server CA Configuration

▶ Enroll Certification

Enroll Certification using File

Use this feature to enroll certification from a file.

Certification GUID

Use this feature to input the certification GUID.

Commit Changes and Exit

Use this feature to save all changes and exit TLS settings.

Discard Changes and Exit

Use this feature to discard all changes and exit TLS settings.

► Delete Certification

Use this feature to delete certification. The options include **Disabled** and Enabled.

6.4 IPMI

Use this tab page to configure Intelligent Platform Management Interface (IPMI) settings.

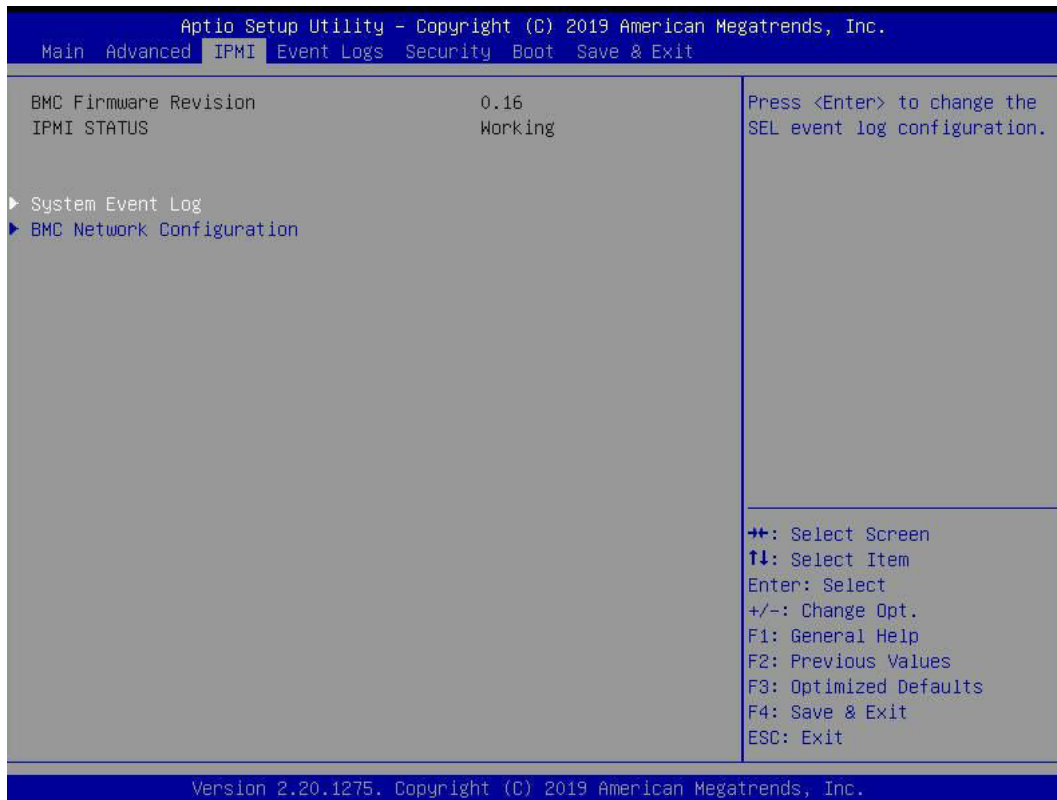

BMC Firmware Revision

This item indicates the IPMI firmware revision used in your system.

IPMI Status (Baseboard Management Controller)

This item indicates the status of the IPMI firmware installed in your system.

► System Event Log

Enabling/Disabling Options

SEL Components

Select Enabled for all system event logging at bootup. The options are **Enabled** and Disabled.

Erasing Settings

Erase SEL

Select Yes, On next reset to erase all system event logs upon next system reboot. Select Yes, On every reset to erase all system event logs upon each system reboot. Select No

to keep all system event logs after each system reboot. The options are **No**, Yes, On next reset, and Yes, On every reset.

When SEL is Full

This feature allows the user to decide what the BIOS should do when the system event log is full. Select Erase Immediately to erase all events in the log when the system event log is full. The options are **Do Nothing** and Erase Immediately.

Note: After making changes on a setting, be sure to reboot the system for the changes to take effect.

► BMC Network Configuration

BMC Network Configuration

Update IPMI LAN Configuration

Select Yes for the BIOS to implement all IP/MAC address changes at the next system boot. The options are **No** and Yes.

Configure IPV4 Support

This section displays static configuration features for IPV4 support.

IPMI LAN Selection

This item displays the IPMI LAN setting. The default setting is **Failover**.

IPMI Network Link Status

This item displays the IPMI Network Link status. The default setting is **Dedicated LAN**.

****If the item above is set to Yes, the following item will become available for configuration:***

Configuration Address Source

This feature allows the user to select the source of the IP address for this computer. If Static is selected, you will need to know the IP address of this computer and enter it to the system manually in the field. If DHCP is selected, the BIOS will search for a DHCP (Dynamic Host Configuration Protocol) server in the network that is attached to and request the next available IP address for this computer. The options are Static and **DHCP**.

****If the item above is set to Static, the following items will become available for configuration:***

Station IP Address

This item displays the Station IP address for this computer. This should be in decimal and in dotted quad form.

Subnet Mask

This item displays the sub-network that this computer belongs to. The value of each three-digit number separated by dots should not exceed 255.

Station MAC Address

This item displays the Station MAC address for this computer. Mac addresses are 6 two-digit hexadecimal numbers.

Gateway IP Address

This item displays the Gateway IP address for this computer. This should be in decimal and in dotted quad form (i.e., 172.31.0.1).

VLAN

This item configures the virtual LAN settings. The options are **Disabled** and Enable.

Configure IPV6 Support

This section displays configuration features for IPV6 support.

IPV6 Support

Use this feature to enable IPV6 support. The options are **Enabled** and Disabled.

Configuration Address Source

This feature allows the user to select the source of the IP address for this computer. If Static is selected, you will need to know the IP address of this computer and enter it to the system manually in the field. If DHCP is selected, the BIOS will search for a DHCP (Dynamic Host Configuration Protocol) server in the network that is attached to and request the next available IP address for this computer. The options are **DHCP** and Static.

****If the item "Configuration Address Source" above is set to Static, the following items will become available for configuration:***

- Station IPV6 Address
- Prefix Length
- IPV6 Router1 IP Address

6.5 Event Logs

Use this tab page to configure Event Log settings.

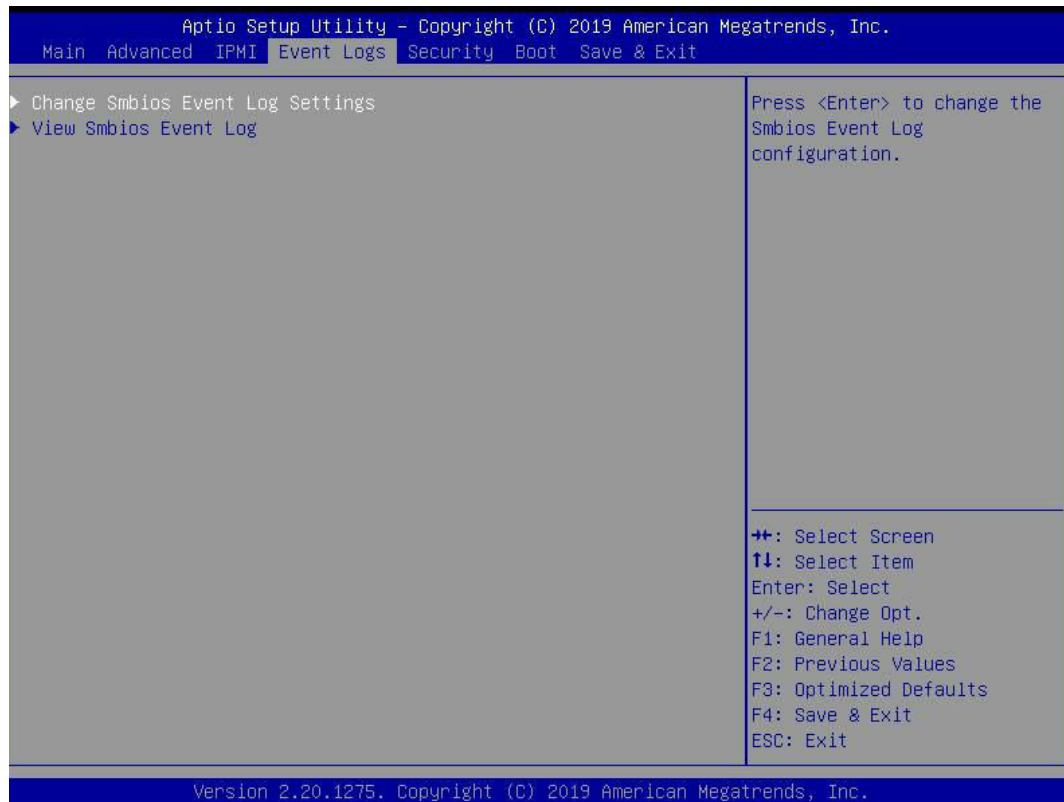

▶ Change SMBIOS Event Log Settings

This feature allows the user to configure SMBIOS Event settings.

Enabling/Disabling Options

SMBIOS Event Log

Select Enabled to enable SMBIOS (System Management BIOS) Event Logging during system boot. The options are Disabled and **Enabled**.

Erasing Settings

Erase Event Log

Select Yes to erase all error events in the SMBIOS (System Management BIOS) log before an event logging is initialized at bootup. The options are **No**, Yes, Next reset, and Yes, Every reset.

When Log is Full

Select Erase Immediately to immediately erase all errors in the SMBIOS event log when the event log is full. Select Do Nothing for the system to do nothing when the SMBIOS event log is full. The options are **Do Nothing** and Erase Immediately.

SMBIOS Event Log Standard Settings

Log System Boot Event

Select Enabled to log system boot events. The options are Enabled and **Disabled**.

MECI (Multiple Event Count Increment)

Enter the increment value for the multiple event counter. Enter a number between 1 to 255. The default setting is **1**.

METW (Multiple Event Count Time Window)

This item is used to determine how long (in minutes) the multiple event counter should wait before generating a new event log. Enter a number between 0 to 99. The default setting is **60**.

Note: Please reboot the system for these changes to take effect.

►View SMBIOS Event Log

When Event Logging is on, this item allows the user to view the entries in the SMBIOS event log. The following categories are displayed:

Date/Time/Error Code/Severity

6.6 Security

Use this tab page to configure Security settings.

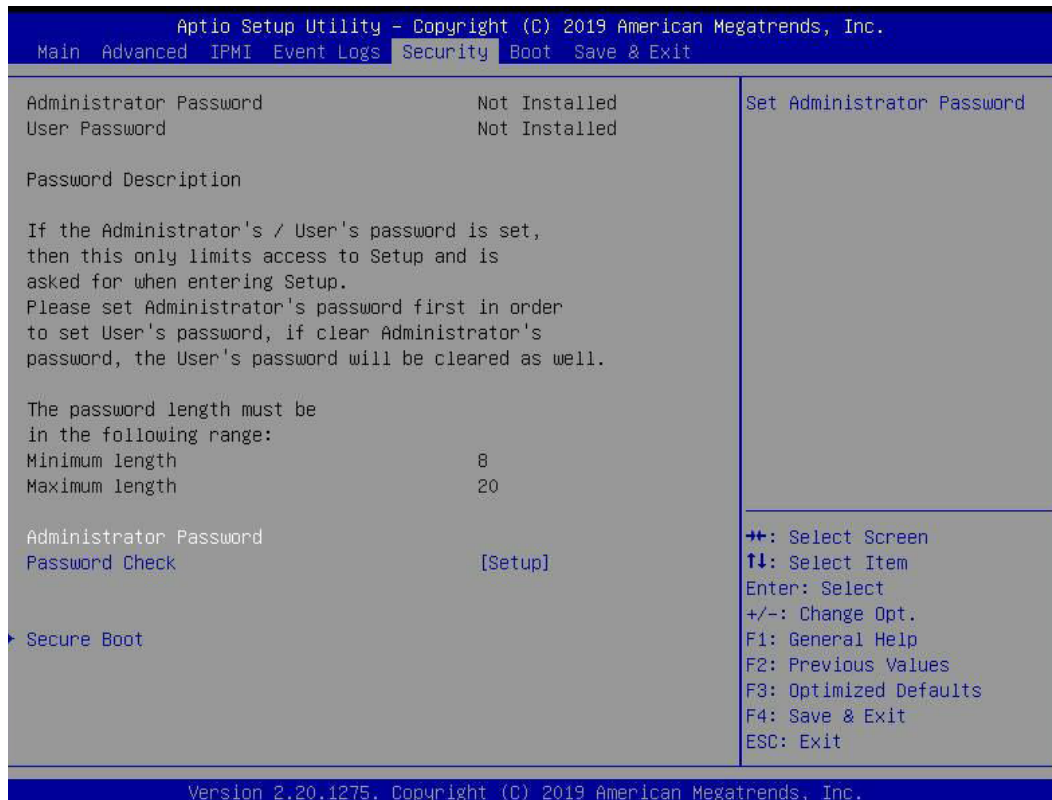

Administrator Password

Press Enter to create a new, or change an existing Administrator password.

Password Check

Select Setup for the system to check for a password at Setup. Select Always for the system to check for a password at bootup or upon entering the BIOS Setup utility. The options are **Setup** and **Always**.

▶ Secure Boot

This section contains options and menus for securing your boot mode and for key management.

Attempt Secure Boot

This option allows you specify when the Platform Key (PK) is enrolled. When enabled, the System Mode is user deployed, and the CSM function is disabled. Options include **Enabled** and **Disabled**.

Secure Boot Mode

Use this item to select the secure boot mode. The options are **Standard** and **Custom**.

CSM Support

Select Enabled to support the EFI Compatibility Support Module (CSM), which provides compatibility support for traditional legacy BIOS for system boot. The options are Disabled and **Enabled**.

▶ Key Management

This submenu allows the user to configure the following Key Management settings.

▶ Install Factory Default Keys

Select Yes to install all default secure keys set by the manufacturer. The options are **Yes** and No.

▶ Enroll EFI Image

This allows the image to run in Secure Boot Mode, and enroll SHA256 hash of the binary into an Authorized Signature Database (db).

▶ Save All Secure Boot Variables

This feature allows the user to decide if all secure boot variables should be saved.

▶ Platform Key (PK)

This feature allows the user to configure the settings of the platform keys.

Set New Key

Select Yes to load the new platform keys (PK) from the manufacturer's defaults. Select No to load the platform keys from a file. The options are **Yes** and No.

Provision Factory Default Keys

Select Enabled to install the default Secure-Boot keys set by the manufacturer. The options are **Disabled** and Enabled.

▶ Key Exchange Keys

Set New Key

Select Yes to load the KEK from the manufacturer's defaults. Select No to load the KEK from a file. The options are Yes and No.

Append Key

Select Yes to add the KEK from the manufacturer's defaults list to the existing KEK. Select No to load the KEK from a file. The options are Yes and No.

▶ Authorized Signatures**Set New Key**

Select Yes to load the database from the manufacturer's defaults. Select No to load the DB from a file. The options are Yes and No.

Append Key

Select Yes to add the database from the manufacturer's defaults to the existing DB. Select No to load the DB from a file. The options are Yes and No.

▶ Forbidden Signatures**Set New Key**

Select Yes to load the DBX from the manufacturer's defaults. Select No to load the DBX from a file. The options are Yes and No.

Append Key

Select Yes to add the DBX from the manufacturer's defaults to the existing DBX. Select No to load the DBX from a file. The options are Yes and No.

▶ Authorized TimeStamps**Set New Key**

Select Yes to load the DBT from the manufacturer's defaults. Select No to load the DBT from a file. The options are Yes and No.

Append Key

Select Yes to add the DBT from the manufacturer's defaults list to the existing DBT. Select No to load the DBT from a file. The options are Yes and No.

▶ OsRecovery Signature

This item uploads and installs an OSRecovery Signature. You may select options for Set New for a factory default key, or select Append to get it from a file. The file formats accepted are:

- 1) Public Key Certificate
 - a. EFI Signature List
 - b. EFI CERT X509 (DER Encoded)
 - c. EFI CERT RSA2048 (bin)
 - d. EFI SERT SHA256 (bin)
- 2) EFI Time Based Authenticated Variable

When prompted, select "Yes" to load Factory Defaults or "No" to load from a file.

6.7 Boot

Use this tab page to configure Boot Settings.

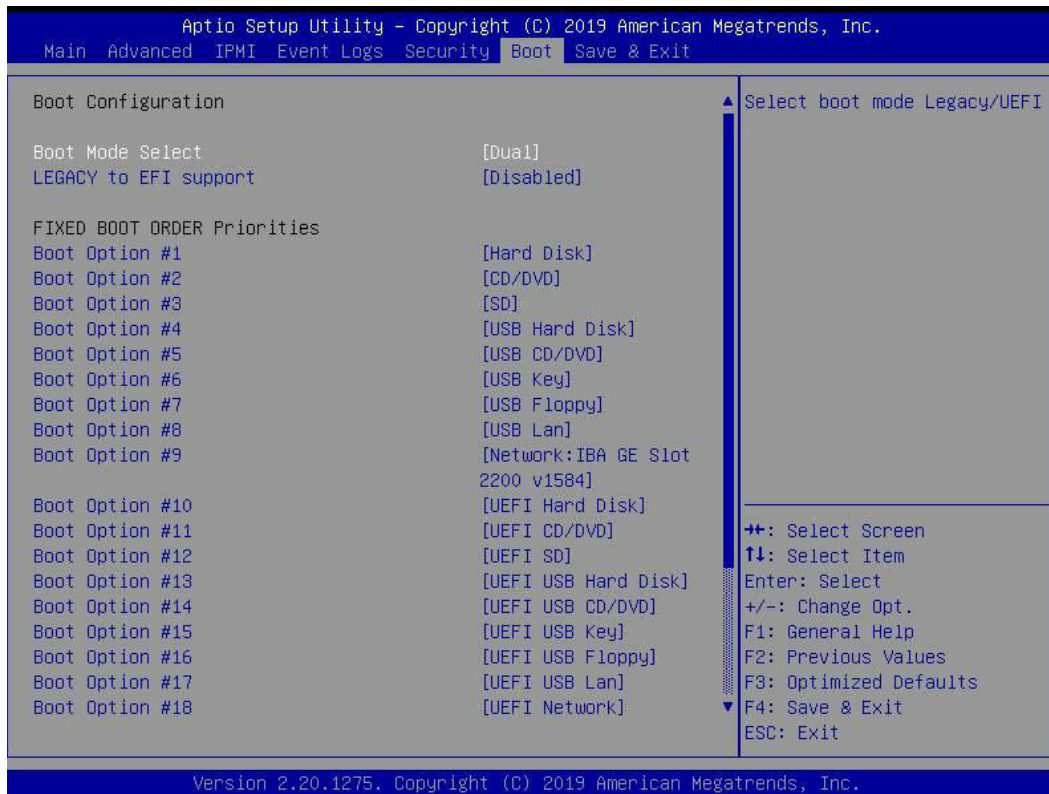

Boot Mode Select

Use this item to select the type of device that the system is going to boot from. The options are Legacy, UEFI, and **Dual**. The default setting is **Dual**.

Legacy to EFI Support

This option enables or disables the system to boot to an EFI OS after the boot failed from the legacy boot order. The options include **Disabled** and Enabled.

FIXED BOOT ORDER Priorities Section

This option prioritizes the order of bootable devices that the system to boot from. Press <Enter> on each entry from top to bottom to select devices.

► Delete Boot Option

Use this feature to remove a pre-defined boot device from which the system will boot during startup. The setting is [Select one to Delete].

► UEFI Application Boot Priorities

This feature allows the user to specify which UEFI devices are boot devices.

- Boot Option #1

▶ **Hard Disk Drive BBS Priorities**

This feature allows the user to specify which hard disk drive devices are boot devices.

▶ **NETWORK Drive BBS Priorities**

This feature allows the user to specify which network drive devices are boot devices.

6.8 Save & Exit

Use this tab page to configure Save & Exit settings.

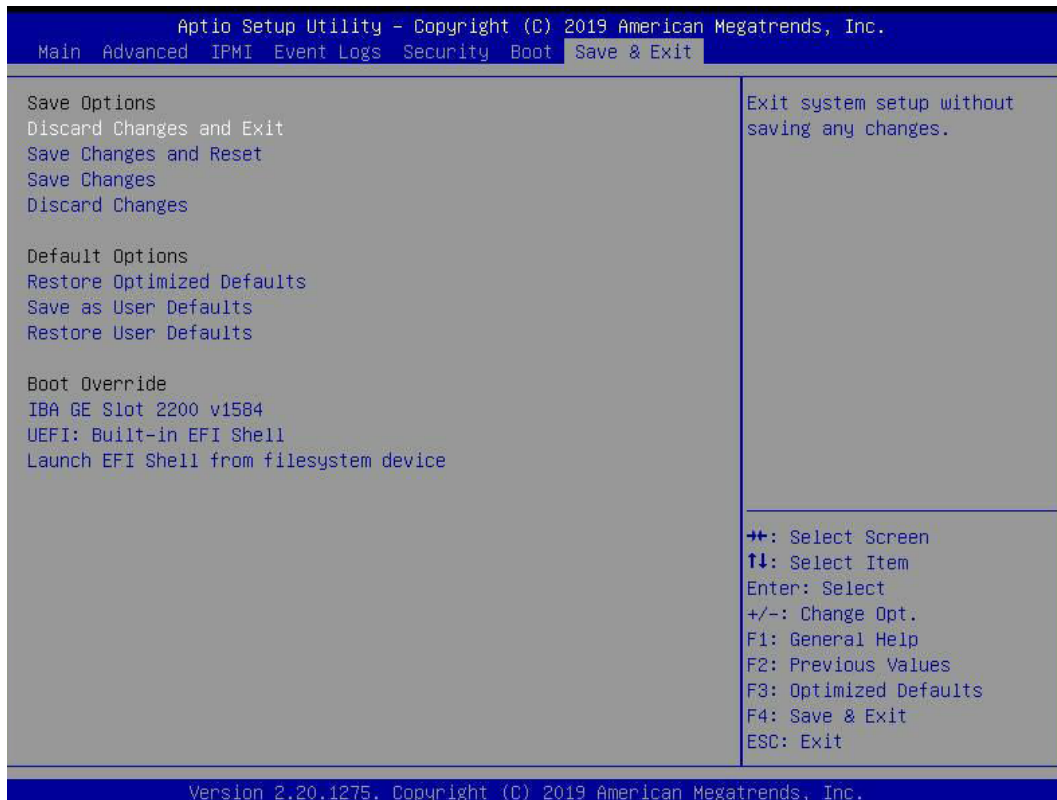

Discard Changes and Exit

Select this option to quit the BIOS Setup without making any permanent changes to the system configuration, and reboot the computer. Select Discard Changes and Exit from the Exit menu and press <Enter>.

Save Changes and Reset

Select this option to reset the system after saving the changes.

Save Changes

After completing the system configuration changes, select this option to save the changes you have made. This will not reset (reboot) the system.

Discard Changes

Select this option and press <Enter> to discard all the changes and return to the AMI BIOS utility Program.

Default Options

Restore Optimized Defaults

To set this feature, select Restore Defaults from the Save & Exit menu and press <Enter>. These are factory settings designed for maximum system stability, but not for maximum performance.

Save as User Defaults

To set this feature, select Save as User Defaults from the Exit menu and press <Enter>. This enables the user to save any changes to the BIOS setup for future use.

Restore User Defaults

To set this feature, select Restore User Defaults from the Exit menu and press <Enter>. Use this feature to retrieve user-defined settings that were saved previously.

Boot Override Section

Listed on this section are other boot options for the system (i.e., Built-in EFI shell). Select an option and press <Enter>. Your system will boot to the selected boot option.

6.9 BIOS Update Using IPMI

If necessary, the system BIOS can be updated using IPMI. Documentation on IPMI is available at <http://www.supermicro.com/products/nfo/IPMI.cfm>.

1. Download the BIOS file using the link on the server web page. Unzip and save it.
2. Access the IPMI web interface. Enter the IP address and log in. The default username and password are ADMIN/ADMIN. (For details on IPMI, use the link above.)
3. Click the **Maintenance** tab, then **BIOS Update**.

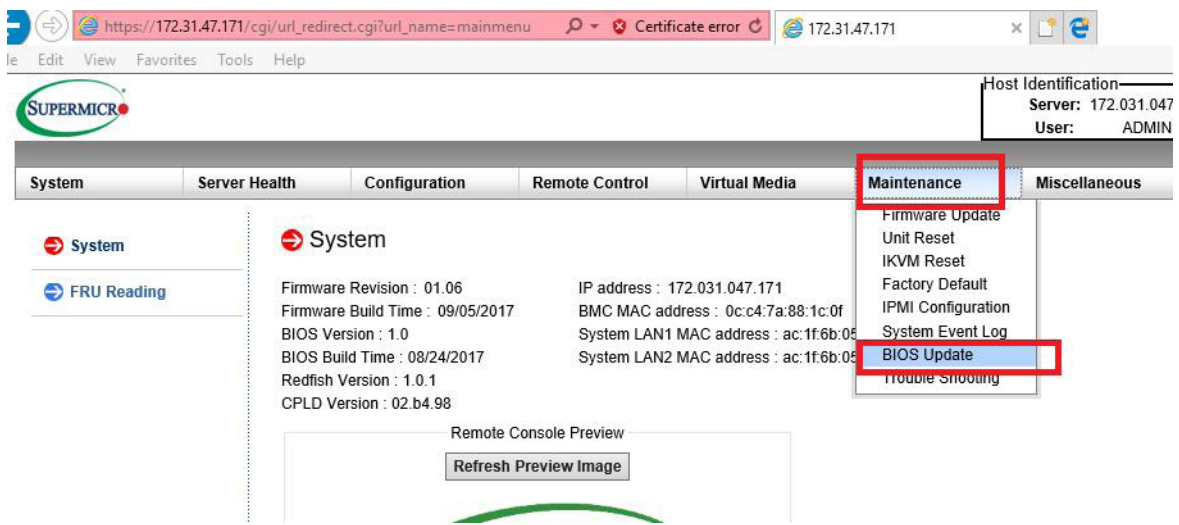

Figure 6-1. IPMI Maintenance Tab

4. **Browse** to select the saved BIOS file and click **Open**.

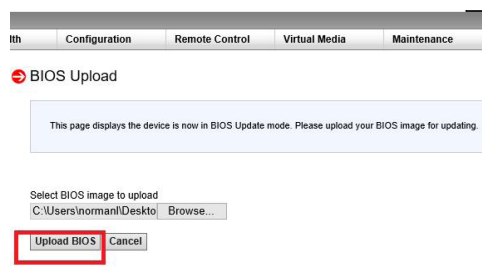

Figure 6-2. Browse and Upload Dialog

5. Click the **Upload BIOS** button. The message appears, "Uploading image & checking BIOS information... Please wait. This may take a while."

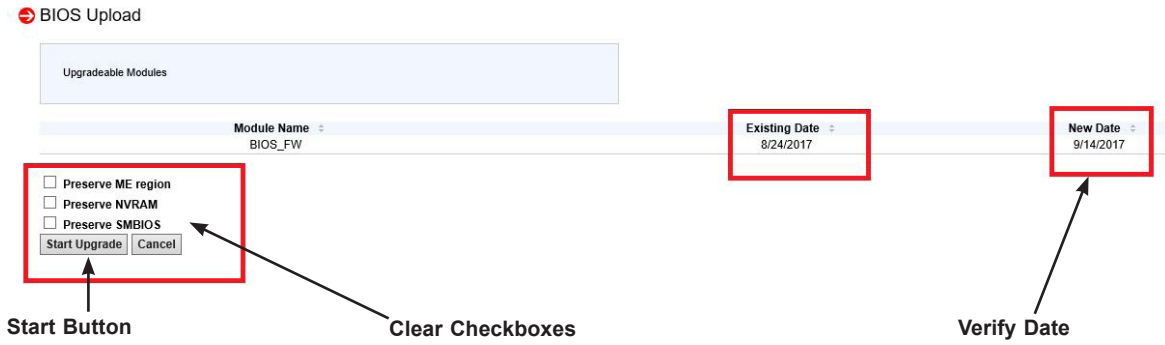

Figure 6-3. Start Upgrade Dialog

6. In the Start Upgrade dialog, make sure the three checkboxes are not checked, and verify the date of the BIOS file you uploaded before proceeding.
7. Click the **Start Upgrade** button.

Appendix A

IPMI Crash Dump

In the event of a processor internal error (IERR) that crashes your system, you may want to provide information to support staff. You can download a crash dump of status information using IPMI. The IPMI manual is available at <https://www.supermicro.com/solutions/IPMI.cfm>.

Check IPMI Error Log

1. Access the IPMI web interface.
2. Click the **Server Health** tab, then **Event Log** to verify an IERR error.

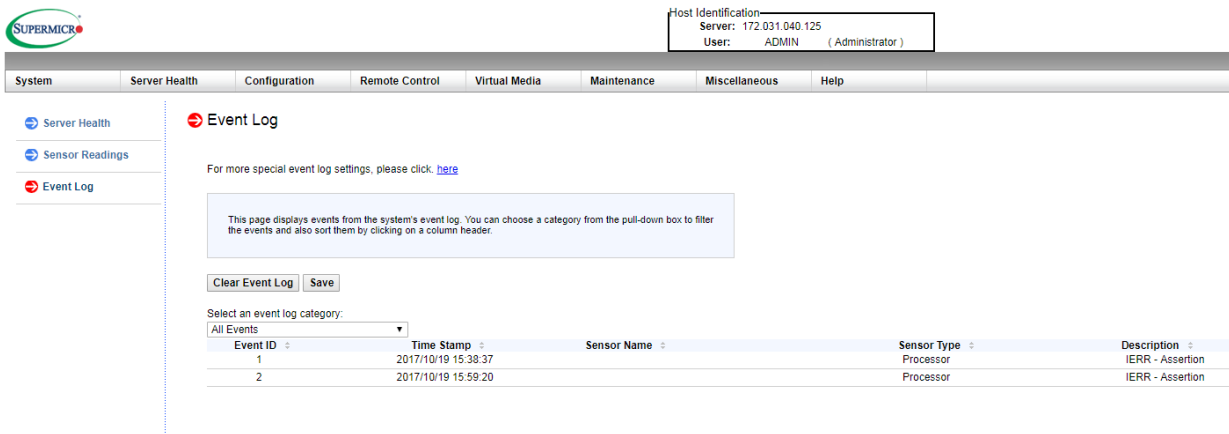

The screenshot shows the IPMI web interface. At the top right, there is a box for Host Identification: Server: 172.031.040.125, User: ADMIN (Administrator). Below this is a navigation bar with tabs: System, Server Health, Configuration, Remote Control, Virtual Media, Maintenance, Miscellaneous, and Help. The 'Server Health' tab is active, and the 'Event Log' sub-tab is selected. On the left, there is a sidebar with 'Event Log' highlighted. The main content area shows a message: 'This page displays events from the system's event log. You can choose a category from the pull-down box to filter the events and also sort them by clicking on a column header.' Below this message are 'Clear Event Log' and 'Save' buttons. A dropdown menu is set to 'All Events'. Below the dropdown is a table with the following data:

Event ID	Time Stamp	Sensor Name	Sensor Type	Description
1	2017/10/19 15:38:37		Processor	IERR - Assertion
2	2017/10/19 15:59:20		Processor	IERR - Assertion

Figure A-1. IPMI Event Log

In the event of an IERR, the BMC executes a crash dump. You must download the crash dump and save it.

Downloading the Crash Dump File

1. In the IPMI interface, click the **Miscellaneous** tab, then the **Trouble Shooting** option.
2. Click the **Dump** button and wait five minutes for the file to be created. (No confirmation message will appear.)
3. Click the **Download** button and a Save As dialog appears.
4. Save the zipped dump file, noting the name and location.

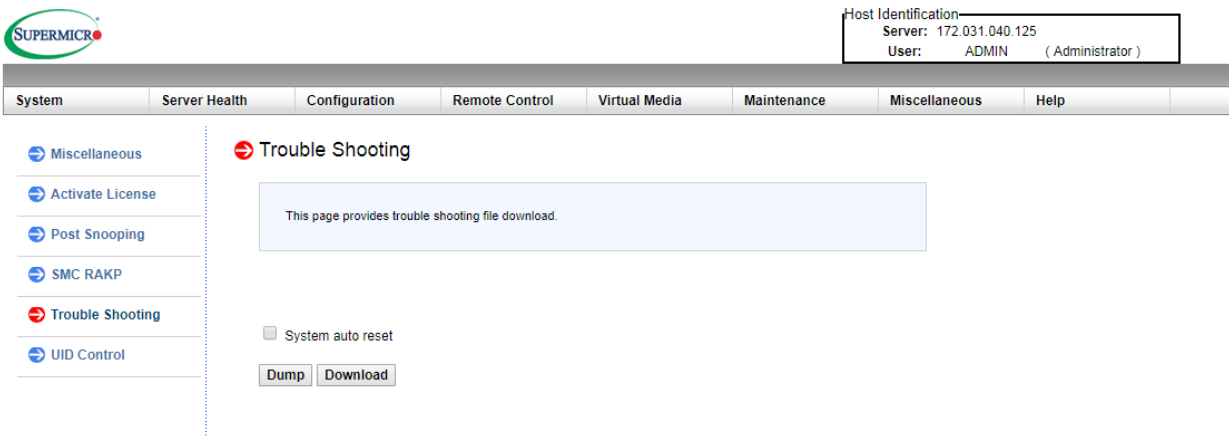

Figure A-2. IPMI Crash Dump Download

Note: The **System auto reset** check box dictates behavior after an IERR. If checked, the system will restart automatically, and the dump file will be erased. If not, the system remains in a failed state. Do not check this box until after the dump file has been sent to Support.

Appendix B

Standardized Warning Statements for AC Systems

About Standardized Warning Statements

The following statements are industry standard warnings, provided to warn the user of situations which have the potential for bodily injury. Should you have questions or experience difficulty, contact Supermicro's Technical Support department for assistance. Only certified technicians should attempt to install or configure components.

Read this appendix in its entirety before installing or configuring components in the Supermicro chassis.

These warnings may also be found on our website at http://www.supermicro.com/about/policies/safety_information.cfm.

Warning Definition



Warning! This warning symbol means danger. You are in a situation that could cause bodily injury. Before you work on any equipment, be aware of the hazards involved with electrical circuitry and be familiar with standard practices for preventing accidents.

警告の定義

この警告サインは危険を意味します。

人身事故につながる可能性がありますので、いずれの機器でも動作させる前に、電気回路に含まれる危険性に注意して、標準的な事故防止策に精通して下さい。

此警告符号代表危險。

您正处于可能受到严重伤害的工作环境中。在您使用设备开始工作之前，必须充分意识到触电的危险，并熟练掌握防止事故发生的标准工作程序。请根据每项警告结尾的声明号码找到此设备的安全性警告说明的翻译文本。

此警告符號代表危險。

您正處於可能身體可能會受損傷的工作環境中。在您使用任何設備之前，請注意觸電的危險，並且要熟悉預防事故發生的標準工作程序。請依照每一注意事項後的號碼找到相關的翻譯說明內容。

Warnung

WICHTIGE SICHERHEITSHINWEISE

Dieses Warnsymbol bedeutet Gefahr. Sie befinden sich in einer Situation, die zu Verletzungen führen kann. Machen Sie sich vor der Arbeit mit Geräten mit den Gefahren elektrischer Schaltungen und den üblichen Verfahren zur Vorbeugung vor Unfällen vertraut. Suchen Sie mit der am Ende jeder Warnung angegebenen Anweisungsnummer nach der jeweiligen Übersetzung in den übersetzten Sicherheitshinweisen, die zusammen mit diesem Gerät ausgeliefert wurden.

BEWAHREN SIE DIESE HINWEISE GUT AUF.

INSTRUCCIONES IMPORTANTES DE SEGURIDAD

Este símbolo de aviso indica peligro. Existe riesgo para su integridad física. Antes de manipular cualquier equipo, considere los riesgos de la corriente eléctrica y familiarícese con los procedimientos estándar de prevención de accidentes. Al final de cada advertencia encontrará el número que le ayudará a encontrar el texto traducido en el apartado de traducciones que acompaña a este dispositivo.

GUARDE ESTAS INSTRUCCIONES.

IMPORTANTES INFORMATIONS DE SÉCURITÉ

Ce symbole d'avertissement indique un danger. Vous vous trouvez dans une situation pouvant entraîner des blessures ou des dommages corporels. Avant de travailler sur un équipement, soyez conscient des dangers liés aux circuits électriques et familiarisez-vous avec les procédures couramment utilisées pour éviter les accidents. Pour prendre connaissance des traductions des avertissements figurant dans les consignes de sécurité traduites qui accompagnent cet appareil, référez-vous au numéro de l'instruction situé à la fin de chaque avertissement.

CONSERVEZ CES INFORMATIONS.

תקנון הזהרות אזהרה

הזהרות הבאות הן אזהרות על פי תקני התעשייה, על מנת להזהיר את המשתמש מפני חבלה פיזית אפשרית. במידה ויש שאלות או היתקלות בבעיה כלשהי, יש ליצור קשר עם מחלקת תמיכה טכנית של סופרמיקרו. טכנאים מוסמכים בלבד רשאים להתקין או להגדיר את הרכיבים. יש לקרוא את הנספח במלואו לפני התקנת או הגדרת הרכיבים במארזי סופרמיקרו.

اَكْ ف حالة وُكِي اَي تتسبب ف اصابة جسدهُ هذا الزهز عُ خطر! تحذُرُ .
قبل اَي تعول على اَي هعدات، كي على علن بالوخاطز ال اُجوة عي الذوائر
الكهزبائِة
وكي على دراةُ بالووارسات النقاائِة لو عُ وقع اَي حادث
استخدم رِقن الب اِي الو صُص ف هاةُ كل تحذُرُ للعشر تزجوتها

안전을 위한 주의사항

경고!

이 경고 기호는 위험이 있음을 알려 줍니다. 작업자의 신체에 부상을 야기 할 수 있는 상태에 있게 됩니다. 모든 장비에 대한 작업을 수행하기 전에 전기회로와 관련된 위험요소들을 확인하시고 사전에 사고를 방지할 수 있도록 표준 작업절차를 준수해 주시기 바랍니다.

해당 번역문을 찾기 위해 각 경고의 마지막 부분에 제공된 경고문 번호를 참조하십시오

BELANGRIJKE VEILIGHEIDSINSTRUCTIES

Dit waarschuwings symbool betekent gevaar. U verkeert in een situatie die lichamelijk letsel kan veroorzaken. Voordat u aan enige apparatuur gaat werken, dient u zich bewust te zijn van de bij een elektrische installatie betrokken risico's en dient u op de hoogte te zijn van de standaard procedures om ongelukken te voorkomen. Gebruik de nummers aan het eind van elke waarschuwing om deze te herleiden naar de desbetreffende locatie.

BEWAAR DEZE INSTRUCTIES

Installation Instructions



Warning! Read the installation instructions before connecting the system to the power source.

設置手順書

システムを電源に接続する前に、設置手順書をお読み下さい。

警告

将此系统连接电源前,请先阅读安装说明。

警告

將系統與電源連接前，請先閱讀安裝說明。

Warnung

Vor dem Anschließen des Systems an die Stromquelle die Installationsanweisungen lesen.

¡Advertencia!

Lea las instrucciones de instalación antes de conectar el sistema a la red de alimentación.

Attention

Avant de brancher le système sur la source d'alimentation, consulter les directives d'installation.

יש לקרוא את הוראות התקנה לפני חיבור המערכת למקור מתח.

اقرأ إرشادات التركيب قبل توصيل النظام إلى مصدر للطاقة

시스템을 전원에 연결하기 전에 설치 안내를 읽어주십시오.

Waarschuwing

Raadpleeg de installatie-instructies voordat u het systeem op de voedingsbron aansluit.

Circuit Breaker



Warning! This product relies on the building's installation for short-circuit (overcurrent) protection. Ensure that the protective device is rated not greater than: 250 V, 20 A.

サーキット・ブレーカー

この製品は、短絡(過電流)保護装置がある建物での設置を前提としています。

保護装置の定格が250 V、20 Aを超えないことを確認下さい。

警告

此产品的短路(过载电流)保护由建筑物的供电系统提供,确保短路保护设备的额定电流不大于250V,20A。

警告

此產品的短路(過載電流)保護由建築物的供電系統提供,確保短路保護設備的額定電流不大於250V,20A。

Warnung

Dieses Produkt ist darauf angewiesen, dass im Gebäude ein Kurzschluss- bzw. Überstromschutz installiert ist. Stellen Sie sicher, dass der Nennwert der Schutzvorrichtung nicht mehr als: 250 V, 20 A beträgt.

¡Advertencia!

Este equipo utiliza el sistema de protección contra cortocircuitos (o sobrecorrientes) del edificio. Asegúrese de que el dispositivo de protección no sea superior a: 250 V, 20 A.

Attention

Pour ce qui est de la protection contre les courts-circuits (surtension), ce produit dépend de l'installation électrique du local. Vérifiez que le courant nominal du dispositif de protection n'est pas supérieur à :250 V, 20 A.

מוצר זה מסתמך על הגנה המותקנת במבנים למניעת קצר חשמלי. יש לוודא כי המכשיר המגן מפני הקצר החשמלי הוא לא יותר מ-250VDC, 20A

هذا المنتج يعتمد على معدات الحماية مه الدوائر القصيرة التي تم تثبيتها في المبنى
تأكد من أن تقييم الجهاز الوقائي ليس أكثر من : 20A, 250V

경고!

이 제품은 전원의 단락(과전류)방지에 대해서 전적으로 건물의 관련 설비에 의존합니다. 보호장치의 정격이 반드시 250V(볼트), 20A(암페어)를 초과하지 않도록 해야 합니다.

Waarschuwing

Dit product is afhankelijk van de kortsluitbeveiliging (overspanning) van uw elektrische installatie. Controleer of het beveiligde apparaat niet groter gedimensioneerd is dan 250V, 20A.

Power Disconnection Warning



Warning! The system must be disconnected from all sources of power and the power cord removed from the power supply module(s) before accessing the chassis interior to install or remove system components.

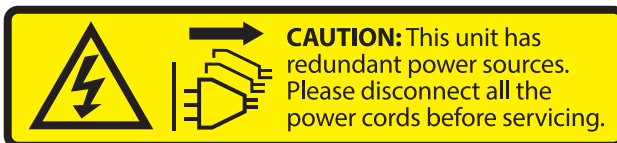

電源切斷の警告

システムコンポーネントの取り付けまたは取り外しのために、シャーシ内部にアクセスするには、システムの電源はすべてのソースから切斷され、電源コードは電源モジュールから取り外す必要があります。

警告

在你打开机箱并安装或移除内部器件前,必须将系统完全断电,并移除电源线。

警告

在您打開機殼安裝或移除內部元件前，必須將系統完全斷電，並移除電源線。

Warnung

Das System muss von allen Quellen der Energie und vom Netzanschlusskabel getrennt sein, das von den Spg.Versorgungsteilmodulen entfernt wird, bevor es auf den Chassisinnenraum zurückgreift, um Systemsbestandteile anzubringen oder zu entfernen.

¡Advertencia!

El sistema debe ser disconnected de todas las fuentes de energía y del cable eléctrico quitado de los módulos de fuente de alimentación antes de tener acceso el interior del chasis para instalar o para quitar componentes de sistema.

Attention

Le système doit être débranché de toutes les sources de puissance ainsi que de son cordon d'alimentation secteur avant d'accéder à l'intérieur du chasis pour installer ou enlever des composants de système.

אזהרה מפני ניתוק חשמלי

אזהרה!

יש לנתק את המערכת מכל מקורות החשמל ויש להסיר את כבל החשמלי מהספק לפני גישה לחלק הפנימי של המארז לצורך התקנת או הסרת רכיבים.

يجب فصح انظاو من جميع مصادر انطاقت وإزانت سهك انكهرباء من وحدة امداد انطاقت قيم

انصل إلى انمناطق انداخهيت نههيكم نتشيج أو إزانت مكنناث الجهاز

경고!

시스템에 부품들을 장착하거나 제거하기 위해서는 새시 내부에 접근하기 전에 반드시 전원 공급장치로부터 연결되어있는 모든 전원과 전기코드를 분리해주어야 합니다.

Waarschuwing

Voordat u toegang neemt tot het binnenwerk van de behuizing voor het installeren of verwijderen van systeem onderdelen, dient u alle spanningsbronnen en alle stroomkabels aangesloten op de voeding(en) van de behuizing te verwijderen

Equipment Installation



Warning! Only trained and qualified personnel should be allowed to install, replace, or service this equipment.

機器の設置

トレーニングを受け認定された人だけがこの装置の設置、交換、またはサービスを許可されていません。

警告

只有经过培训且具有资格的人员才能进行此设备的安装、更换和维修。

警告

只有經過受訓且具資格人員才可安裝、更換與維修此設備。

Warnung

Das Installieren, Ersetzen oder Bedienen dieser Ausrüstung sollte nur geschultem, qualifiziertem Personal gestattet werden.

¡Advertencia!

Solamente el personal calificado debe instalar, reemplazar o utilizar este equipo.

Attention

Il est vivement recommandé de confier l'installation, le remplacement et la maintenance de ces équipements à des personnels qualifiés et expérimentés.

אזהרה!

צוות מוסמך בלבד רשאי להתקין, להחליף את הציוד או לתת שירות עבור הציוד.

والمدربيه لتزكيب واستبدال أو خدمة هذا الجهاز يجب أن يسمح فقط للمظفيه المؤهليه

경고!

훈련을 받고 공인된 기술자만이 이 장비의 설치, 교체 또는 서비스를 수행할 수 있습니다.

Waarschuwing

Deze apparatuur mag alleen worden geïnstalleerd, vervangen of hersteld door geschoold en gekwalificeerd personeel.

Restricted Area



Warning! This unit is intended for installation in restricted access areas. A restricted access area can be accessed only through the use of a special tool, lock and key, or other means of security. (This warning does not apply to workstations).

アクセス制限区域

このユニットは、アクセス制限区域に設置されることを想定しています。

アクセス制限区域は、特別なツール、鍵と錠前、その他のセキュリティの手段を用いてのみ出入りが可能です。

警告

此部件应安装在限制进出的场所，限制进出的场所指只能通过使用特殊工具、锁和钥匙或其它安全手段进出的场所。

警告

此裝置僅限安裝於進出管制區域，進出管制區域係指僅能以特殊工具、鎖頭及鑰匙或其他安全方式才能進入的區域。

Warnung

Diese Einheit ist zur Installation in Bereichen mit beschränktem Zutritt vorgesehen. Der Zutritt zu derartigen Bereichen ist nur mit einem Spezialwerkzeug, Schloss und Schlüssel oder einer sonstigen Sicherheitsvorkehrung möglich.

¡Advertencia!

Esta unidad ha sido diseñada para instalación en áreas de acceso restringido. Sólo puede obtenerse acceso a una de estas áreas mediante la utilización de una herramienta especial, cerradura con llave u otro medio de seguridad.

Attention

Cet appareil doit être installée dans des zones d'accès réservés. L'accès à une zone d'accès réservé n'est possible qu'en utilisant un outil spécial, un mécanisme de verrouillage et une clé, ou tout autre moyen de sécurité.

אזור עם גישה מוגבלת

אזהרה!

יש להתקין את היחידה באזורים שיש בהם הגבלת גישה. הגישה ניתנת בעזרת 'כלי אבטחה בלבד' (מפתח, מנעול וכד.).

تخصيص هذه انحدة نترك بُها ف مناطق محظورة تم .
ممكن اننصل إن منطقت محظورة فقط من خلال استخذاو أداة خاصت
أو أ وس هُت أخري نلالأمما ققم ومفتاح

경고!

이 장치는 접근이 제한된 구역에 설치하도록 되어있습니다. 특수도구, 잠금 장치 및 키, 또는 기타 보안 수단을 통해서만 접근 제한 구역에 들어갈 수 있습니다.

Waarschuwing

Dit apparaat is bedoeld voor installatie in gebieden met een beperkte toegang. Toegang tot dergelijke gebieden kunnen alleen verkregen worden door gebruik te maken van speciaal gereedschap, slot en sleutel of andere veiligheidsmaatregelen.

Battery Handling



Warning! There is the danger of explosion if the battery is replaced incorrectly. Replace the battery only with the same or equivalent type recommended by the manufacturer. Dispose of used batteries according to the manufacturer's instructions

電池の取り扱い

電池交換が正しく行われなかった場合、破裂の危険性があります。交換する電池はメーカーが推奨する型、または同等のものを使用下さい。使用済電池は製造元の指示に従って処分して下さい。

警告

電池更換不當會有爆炸危險。請只使用同類電池或制造商推薦的功能相當的電池更換原有電池。請按製造商的說明處理廢舊電池。

警告

電池更換不當會有爆炸危險。請使用製造商建議之相同或功能相當的電池更換原有電池。請按照製造商的說明指示處理廢棄舊電池。

Warnung

Bei Einsetzen einer falschen Batterie besteht Explosionsgefahr. Ersetzen Sie die Batterie nur durch den gleichen oder vom Hersteller empfohlenen Batterietyp. Entsorgen Sie die benutzten Batterien nach den Anweisungen des Herstellers.

Attention

Danger d'explosion si la pile n'est pas remplacée correctement. Ne la remplacer que par une pile de type semblable ou équivalent, recommandée par le fabricant. Jeter les piles usagées conformément aux instructions du fabricant.

¡Advertencia!

Existe peligro de explosión si la batería se reemplaza de manera incorrecta. Reemplazar la batería exclusivamente con el mismo tipo o el equivalente recomendado por el fabricante. Desechar las baterías gastadas según las instrucciones del fabricante.

אזהרה!

קיימת סכנת פיצוץ של הסוללה במידה והוחלפה בדרך לא תקינה. יש להחליף את הסוללה בסוג התואם מחברת יצרן מומלצת. סילוק הסוללות המשומשות יש לבצע לפי הוראות היצרן.

هناك خطر من انفجار في حالة اسبدال البطارية بطريقة غير صحيحة فعلى
اسبدال البطارية
فقط بنفس النوع أو ما يعادلها مما أوصت به الشركة المصنعة
جخلص من البطاريات المسحومة وفقا لعمليات الشركة الصانعة

경고!

배터리가 올바르게 교체되지 않으면 폭발의 위험이 있습니다. 기존 배터리와 동일하거나 제조사에서 권장하는 동등한 종류의 배터리로만 교체해야 합니다. 제조사의 안내에 따라 사용된 배터리를 처리하여 주십시오.

Waarschuwing

Er is ontplofingsgevaar indien de batterij verkeerd vervangen wordt. Vervang de batterij slechts met hetzelfde of een equivalent type die door de fabrikant aanbevolen wordt. Gebruikte batterijen dienen overeenkomstig fabrieksvoorschriften afgevoerd te worden.

Redundant Power Supplies



Warning! This unit might have more than one power supply connection. All connections must be removed to de-energize the unit.

冗長電源装置

このユニットは複数の電源装置が接続されている場合があります。

ユニットの電源を切るためには、すべての接続を取り外さなければなりません。

警告

此部件连接的电源可能不止一个，必须将所有电源断开才能停止给该部件供电。

警告

此装置连接的电源可能不只一个，必须切断所有电源才能停止对该装置的供电。

Warnung

Dieses Gerät kann mehr als eine Stromzufuhr haben. Um sicherzustellen, dass der Einheit kein Strom zugeführt wird, müssen alle Verbindungen entfernt werden.

¡Advertencia!

Puede que esta unidad tenga más de una conexión para fuentes de alimentación. Para cortar por completo el suministro de energía, deben desconectarse todas las conexiones.

Attention

Cette unité peut avoir plus d'une connexion d'alimentation. Pour supprimer toute tension et tout courant électrique de l'unité, toutes les connexions d'alimentation doivent être débranchées.

אם קיים יותר מספק אחד

אזהרה!

ליחידה יש יותר מחיבור אחד של ספק. יש להסיר את כל החיבורים על מנת לרוקן את היחידה.

قد يكون لهذا الجهاز عدة اتصالات بوحدات امداد الطاقة .

يجب إزالة كافة الاتصالات لعسل الوحدة عن الكهرباء

경고!

이 장치에는 한 개 이상의 전원 공급 단자가 연결되어 있을 수 있습니다. 이 장치에 전원을 차단하기 위해서는 모든 연결 단자를 제거해야만 합니다.

Waarschuwing

Deze eenheid kan meer dan één stroomtoevoeraansluiting bevatten. Alle aansluitingen dienen verwijderd te worden om het apparaat stroomloos te maken.

Backplane Voltage



Warning! Hazardous voltage or energy is present on the backplane when the system is operating. Use caution when servicing.

バックプレーンの電圧

システムの稼働中は危険な電圧または電力が、バックプレーン上にかかっています。

修理する際には注意ください。

警告

当システム正在进行时，背板上有很危险的电压或能量，进行维修时务必小心。

警告

當系統正在進行時，背板上危險的電壓或能量，進行維修時務必小心。

Warnung

Wenn das System in Betrieb ist, treten auf der Rückwandplatine gefährliche Spannungen oder Energien auf. Vorsicht bei der Wartung.

¡Advertencia!

Cuando el sistema está en funcionamiento, el voltaje del plano trasero es peligroso. Tenga cuidado cuando lo revise.

Attention

Lorsque le système est en fonctionnement, des tensions électriques circulent sur le fond de panier. Prendre des précautions lors de la maintenance.

מתח בפנל האחורי

אזהרה!

קיימת סכנת מתח בפנל האחורי בזמן תפעול המערכת. יש להיזהר במהלך העבודה.

هناك خطر من التيار الكهربائي أو الطاقة المتجددة على اللوحة
عندما يكون النظام يعمل كه حذرا عند خدمة هذا الجهاز

경고!

시스템이 동작 중일 때 후면판 (Backplane)에는 위험한 전압이나 에너지가 발생 합니다.
서비스 작업 시 주의하십시오.

Waarschuwing

Een gevaarlijke spanning of energie is aanwezig op de backplane wanneer het systeem in gebruik is. Voorzichtigheid is geboden tijdens het onderhoud.

Comply with Local and National Electrical Codes



Warning! Installation of the equipment must comply with local and national electrical codes.

地方および国の電気規格に準拠

機器の取り付けはその地方および国の電気規格に準拠する必要があります。

警告

设备安装必须符合本地与本国电气法规。

警告

設備安裝必須符合本地與本國電氣法規。

Warnung

Die Installation der Geräte muss den Sicherheitsstandards entsprechen.

¡Advertencia!

La instalación del equipo debe cumplir con las normas de electricidad locales y nacionales.

Attention

L'équipement doit être installé conformément aux normes électriques nationales et locales.

תיאום חוקי החשמל הארצי

אזהרה!

התקנת הציוד חייבת להיות תואמת לחוקי החשמל המקומיים והארציים.

تركيب المعدات الكهربائية يجب أن يمتثل للقوايه المحلية والبطية المتعلقة
بالكهرباء

경고!

현 지역 및 국가의 전기 규정에 따라 장비를 설치해야 합니다.

Waarschuwing

Bij installatie van de apparatuur moet worden voldaan aan de lokale en nationale elektriciteitsvoorschriften.

Product Disposal



Warning! Ultimate disposal of this product should be handled according to all national laws and regulations.

製品の廃棄

この製品を廃棄処分する場合、国の関係する全ての法律・条例に従い処理する必要があります。

警告

本产品的废弃处理应根据所有国家的法律和规章进行。

警告

本產品的廢棄處理應根據所有國家的法律和規章進行。

Warnung

Die Entsorgung dieses Produkts sollte gemäß allen Bestimmungen und Gesetzen des Landes erfolgen.

¡Advertencia!

Al deshacerse por completo de este producto debe seguir todas las leyes y reglamentos nacionales.

Attention

La mise au rebut ou le recyclage de ce produit sont généralement soumis à des lois et/ou directives de respect de l'environnement. Renseignez-vous auprès de l'organisme compétent.

סילוק המוצר

אזהרה!

סילוק סופי של מוצר זה חייב להיות בהתאם להנחיות וחוקי המדינה.

التخلص النهائي من هذا المنتج ينبغي التعامل معه وفقا لجميع القوانين واللوائح الوطنية عند

경고!

이 제품은 해당 국가의 관련 법규 및 규정에 따라 폐기되어야 합니다.

Waarschuwing

De uiteindelijke verwijdering van dit product dient te geschieden in overeenstemming met alle nationale wetten en reglementen.

Hot Swap Fan Warning



Warning! Hazardous moving parts. Keep away from moving fan blades. The fans might still be turning when you remove the fan assembly from the chassis. Keep fingers, screwdrivers, and other objects away from the openings in the fan assembly's housing.

ファン・ホットスワップの警告

警告!回転部品に注意。運転中は回転部(羽根)に触れないでください。シャーシから冷却ファン装置を取り外した際、ファンがまだ回転している可能性があります。ファンの開口部に、指、ドライバー、およびその他のものを近づけないで下さい。

警告!

警告! 危險的可移動性零件。請務必與轉動的风扇叶片保持距離。當您從機架移除風扇裝置，風扇可能仍在轉動。小心不要將手指、螺絲起子和其他物品太靠近風扇

警告

危險的可移動性零件。請務必與轉動的风扇叶片保持距離。當您從機架移除風扇裝置，風扇可能仍在轉動。小心不要將手指、螺絲起子和其他物品太靠近風扇。

Warnung

Gefährlich Bewegende Teile. Von den bewegenden Lüfterblätter fern halten. Die Lüfter drehen sich u. U. noch, wenn die Lüfterbaugruppe aus dem Chassis genommen wird. Halten Sie Finger, Schraubendreher und andere Gegenstände von den Öffnungen des Lüftergehäuses entfernt.

¡Advertencia!

Riesgo de piezas móviles. Mantener alejado de las aspas del ventilador. Los ventiladores podran dar vuelta cuando usted quite el montaje del ventilador del chasis. Mantenga los dedos, los destornilladores y todos los objetos lejos de las aberturas del ventilador

Attention

Pieces mobiles dangereuses. Se tenir a l'écart des lames du ventilateur Il est possible que les ventilateurs soient toujours en rotation lorsque vous retirerez le bloc ventilateur du châssis. Prenez garde à ce que doigts, tournevis et autres objets soient éloignés du logement du bloc ventilateur.

אזהרה!

חלקים נעים מסוכנים. התרחק מלהבי המאוורר בפעולה כאשר מסירים את חלקי המאוורר מהמארז, יתכן והמאווררים עדיין עובדים. יש להרחיק למרחק בטוח את האצבעות וכלי עבודה שונים מהפתחים בתוך המאוורר

تحذير! أجزاء متحركة خطيرة. ابتعد عن شفرات المروحة المتحركة. من الممكن أن المراوح لا تزال تدور عند إزالة كتلة المروحة من الهيكل يجب إبقاء الأصابع ومفكات البراغي وغيرها من الأشياء بعيدا عن الفتحات في كتلة المروحة

경고!

움직이는 위험한 부품. 회전하는 송풍 날개에 접근하지 마세요. 새시로부터 팬 조립품을 제거할 때 팬은 여전히 회전하고 있을 수 있습니다. 팬 조립품 외관의 열려있는 부분들로부터 손가락 및 스크류드라이버, 다른 물체들이 가까이 하지 않도록 배치해 주십시오.

Waarschuwing

Gevaarlijk bewegende onderdelen. Houd voldoende afstand tot de bewegende ventilatorbladen. Het is mogelijk dat de ventilator nog draait tijdens het verwijderen van het ventilatorsamenstel uit het chassis. Houd uw vingers, schroevendraaiers en eventuele andere voorwerpen uit de buurt van de openingen in de ventilatorbehuizing.

Power Cable and AC Adapter



Warning! When installing the product, use the provided or designated connection cables, power cables and AC adaptors. Using any other cables and adaptors could cause a malfunction or a fire. Electrical Appliance and Material Safety Law prohibits the use of UL or CSA -certified cables (that have UL/CSA shown on the cord) for any other electrical devices than products designated by Supermicro only.

電源コードとACアダプター

製品を設置する場合、提供または指定および購入された接続ケーブル、電源コードとACアダプターを、該当する地域の条例や安全基準に適合するコードサイズやプラグと共に使用下さい。他のケーブルやアダプタを使用すると故障や火災の原因になることがあります。

電気用品安全法は、ULまたはCSA認定のケーブル(UL/CSAマークがコードに表記)を Supermicro が指定する製品以外に使用することを禁止しています。

警告

安装此产品时,请使用本身提供的或指定的或采购的连接线,电源线和电源适配器。包含遵照当地法规和安全要求的合规的电源线尺寸和插头。使用其它线材或适配器可能会引起故障或火灾。除了Supermicro所指定的产品,电气用品和材料安全法律规定禁止使用未经UL或CSA认证的线材。(线材上会显示UL/CSA符号)。

警告

安裝此產品時,請使用本身提供的或指定的或採購的連接線,電源線和電源適配器。包含遵照當地法規和安全要求的合規的電源線尺寸和插頭。使用其它線材或適配器可能會引起故障或火災。除了Supermicro所指定的產品,電氣用品和材料安全法律規定禁止使用未經UL或CSA認證的線材。(線材上會顯示UL/CSA符號)。

Warnung

Nutzen Sie beim Installieren des Produkts ausschließlich die von uns zur Verfügung gestellten Verbindungskabeln, Stromkabeln und/oder Adapter, die Ihre örtlichen Sicherheitsstandards einhalten. Der Gebrauch von anderen Kabeln und Adapter können Fehlfunktionen oder Feuer verursachen. Die Richtlinien untersagen das Nutzen von UL oder CAS zertifizierten Kabeln (mit UL/CSA gekennzeichnet), an Geräten oder Produkten die nicht mit Supermicro gekennzeichnet sind.

¡Advertencia!

Cuando instale el producto, utilice la conexión provista o designada o procure cables, Cables de alimentación y adaptadores de CA que cumplan con los códigos locales y los requisitos de seguridad, incluyendo el tamaño adecuado del cable y el enchufe. El uso de otros cables y adaptadores podría causar un mal funcionamiento o un incendio. La Ley de Seguridad de Aparatos Eléctricos y de Materiales prohíbe El uso de cables certificados por UL o CSA (que tienen el certificado UL / CSA en el código) para cualquier otros dispositivos eléctricos que los productos designados únicamente por Supermicro.

Attention

Lors de l'installation du produit, utilisez les cables de connection fournis ou désigné ou achetez des cables, cables de puissance et adaptateurs respectant les normes locales et les conditions de securite y compris les tailles de cables et les prises electriques appropries. L'utilisation d'autres cables et adaptateurs peut provoquer un dysfonctionnement ou un incendie. Appareils électroménagers et la Loi sur la Sécurité Matériel interdit l'utilisation de câbles certifiés- UL ou CSA (qui ont UL ou CSA indiqué sur le code) pour tous les autres appareils électriques sauf les produits désignés par Supermicro seulement.

AC ימאתמו מיי למשח מילבכ

!הרהזא

ךרוצל ומאתוה וא ושכרנ רשא AC מיימאתמו מיקפס, מילבכב שמתשהל שי, רצומה תא מיניקתמ רשאכ לכב שומיש . עקתהו לבכה לש הנוכח הדימ ללוכ, תוימוקמה תוחיטבה תושירדל ומאתוה רשאו, הנקתהה למשחה ירישכמב שומישה יקוחל מאתהב. ילמשח רצק וא הלקתל מורגל לולע, רחא גוסמ מאתמ וא לבכ לש דוק מהילע עיפומ רשאכ) UL-ב או CSA-ב -ב מיכמומה מילבכב שמתשהל רוסיא מייק, תוחיטבה יקוחו דבלב Supermicro י"ע מאתוה רשא רצומב קר אלא, רחא ילמשח רצומ לכ רובע (UL/CSA)

תאלבאלא אארשב מץ וא אדדחמלא וא ארפוטמלא תאליטוטלא מאדחטסאב מץ, אגתנמלא בייקרת דנע לכלז ייפ אב עילחמלא עמאלסלא תאבלטתמו נינאוqb מאזתלאל עמ דדרתמלא ראיטלא תאלוחמו עיילברמלא קיירח וא לטע ייפ בבסטטי דץ ירשא תאלוחמו תאלבאלא יא מאדחטסא. מילסלא סבאלאו לטומוא מץח CSA וא UL לבק נמ אדמטעמלא תאלבאלא מאדחטסא תאדעמלא עיילברמלא אזהאלל עמאלסלא נונאק רזחי Supermicro לבק נמ אדדחמלא עיילברמלא תאגתנמלא רייג ירשא תאדעמ יא עמ (UL/CSA) עמאלע למחתיטלאו

전원 케이블 및 AC 어댑터

경고! 제품을 설치할 때 현지 코드 및 적절한 굵기의 코드와 플러그를 포함한 안전 요구 사항을 준수하여 제공되거나 지정된 연결 혹은 구매 케이블, 전원 케이블 및 AC 어댑터를 사용하십시오.

다른 케이블이나 어댑터를 사용하면 오작동이나 화재가 발생할 수 있습니다. 전기 용품 안전법은 UL 또는 CSA 인증 케이블 (코드에 UL / CSA가 표시된 케이블)을 Supermicro가 지정한 제품 이외의 전기 장치에 사용하는 것을 금지합니다.

Stroomkabel en AC-Adapter

Waarschuwing! Bij het aansluiten van het Product uitsluitend gebruik maken van de geleverde Kabels of een andere geschikte aan te schaffen Aansluitmethode, deze moet altijd voldoen aan de lokale voorschriften en veiligheidsnormen, inclusief de juiste kabeldikte en stekker. Het gebruik van niet geschikte Kabels en/of Adapters kan een storing of brand veroorzaken. Wetgeving voor Elektrische apparatuur en Materiaalveiligheid verbied het gebruik van UL of CSA -gecertificeerde Kabels (met UL/CSA in de code) voor elke andere toepassing dan de door Supermicro hiervoor beoogde Producten.

Appendix C

System Specifications

Processors

Dual AMD EPYC 7003/7002 series processors in SP3 type sockets. (7003 Series Processor drop-in support requires BIOS version 2.0 or newer)

Chipset

System on Chip

BIOS

256 Mb SPI AMI BIOS SM Flash UEFI BIOS

Memory

Sixteen slots, up to 4 TB of ECC DDR4 3200 MHz speed, RDIMM/LRDIMM/3DS/NVDIMM memory
Size up to 256 GB

SATA Controller

On-chip

Storage Drives

Twenty-four hot-swap 2.5" drives total; each node controls six drives
AS -2124BT-HTR – SATA
AS -2124BT-HNTR – Four U.2 NVMe/SATA and two SATA
One M.2 SSD per node, SATA/PCI-E 3.0 x4, Form Factor: 2280, 22110; M-Key
One SATA DOM per node

PCI Expansion Slots

Two PCI-E 4.0 x16 low profile (6.6" long) slots

Motherboard

H12DST-B; 17" x 16.8" (431.8 mm x 426.72 mm)

Chassis

SC217BHQ+-R2K22BP2; 2U rackmount; (WxHxD) 17.6 x 3.5 x 28.8 in. (447 x 88 x 730 mm)

Power Supply

Model: PWS-2K22A-1R, 80Plus Titanium level
AC Input Voltages: 100-240 VAC
Rated Input Current:
1800W: 200-220Vac
1980W: 220-230Vac
2090W: 230-240Vac
2090W: 180-220Vac (for UL/cUL only)
2200W: 220-240Vac (for UL/cUL only)
2090W: 230-240Vdc (for CCC only)>
Rated Input Frequency: 50-60 Hz
Rated Output Power: +12 V
Max: 100A / Min: 0A (100-127Vac)
Max: 150A / Min: 0A (200-220Vac)
Max: 165A / Min: 0A (220-230Vac)
Max: 174.17A / Min: 0A (230-240Vac)
Max: 174.17A / Min: 0A (180-220Vac, UL/cUL only)
Max: 183.33A / Min: 0A (220-240Vac, UL/cUL only)
Max: 174.17A / Min: 0A (230-240Vdc, CCC only)
Standby +12Vsb: Max: 2.1A / Min: 0A

System Cooling

Four 8-cm mid-chassis fans; two CPU heatsinks per node

Weight

Net Weight: 54.5 lbs (24.7 kg)

Gross Weight: 85 lbs (38.6 g)

Operating Environment

Operating Temperature: 10° to 35° C (50° to 95° F)

Non-operating Temperature: -40° to 70° C (-40° to 158° F)

Operating Relative Humidity: 8% to 90% (non-condensing)

Non-operating Relative Humidity: 5% to 95% (non-condensing)

Regulatory Compliance

FCC, ICES, CE, VCCI, RCM, UKCA, NRTL, CB

Applied Directives, Standards

EMC/EMI: 2014/30/EU (EMC Directive)

Electromagnetic Compatibility Regulations 2016

FCC Part 15 Subpart B

ICES-003

VCCI-CISPR 32

AS/NZS CISPR 32

BS/EN55032

BS/EN55035

CISPR 32

CISPR 24/CISPR 35

BS/EN 61000-3-2

BS/EN 61000-3-3

BS/EN 61000-4-2

BS/EN 61000-4-3

BS/EN 61000-4-4

BS/EN 61000-4-5

BS/EN 61000-4-6

BS/EN 61000-4-8

BS/EN 61000-4-11

Environment:

2011/65/EU (RoHS Directive)

EC 1907/2006 (REACH)

2012/19/EU (WEEE Directive)

California Proposition 65

Product Safety: 2014/35/EU (LVD Directive)

UL/CSA 62368-1 (USA and Canada)

Electrical Equipment (Safety) Regulations 2016

IEC/BS/EN 62368-1

Perchlorate Warning

California Best Management Practices Regulations for Perchlorate Materials: This Perchlorate warning applies only to products containing CR (Manganese Dioxide) Lithium coin cells. "Perchlorate Material-special handling may apply. See www.dtsc.ca.gov/hazardouswaste/perchlorate"

Appendix D

UEFI BIOS Recovery

Warning: Do not upgrade the BIOS unless your system has a BIOS-related issue. Flashing the wrong BIOS can cause irreparable damage to the system. In no event shall Supermicro be liable for direct, indirect, special, incidental, or consequential damages arising from a BIOS update. If you do update the BIOS, do not shut down or reset the system while the BIOS is updating to avoid possible boot failure.

D.1 Overview

The Unified Extensible Firmware Interface (UEFI) provides a software-based interface between the operating system and the platform firmware in the pre-boot environment. The UEFI specification supports an architecture-independent mechanism that will allow the UEFI OS loader stored in an add-on card to boot the system. The UEFI offers clean, hands-off management to a computer during system boot.

D.2 Recovering the UEFI BIOS Image

A UEFI BIOS flash chip consists of a recovery BIOS block and a main BIOS block (a main BIOS image). The recovery block contains critical BIOS codes, including memory detection and recovery codes for the user to flash a healthy BIOS image if the original main BIOS image is corrupted. When the system power is turned on, the recovery block codes execute first. Once this process is complete, the main BIOS code will continue with system initialization and the remaining POST (Power-On Self-Test) routines.

Note 1: Follow the BIOS recovery instructions below for BIOS recovery when the main BIOS block crashes.

Note 2: When the BIOS recovery block crashes:

- Try BIOS update using IPMI as described in Section 6.11 or the following Section D.3.
- Use the Supermicro Update Manager (SUM) Out-of-Band (OOB) (https://www.supermicro.com.tw/products/nfo/SMS_SUM.cfm) to reflash the BIOS.
- Make a Returned Merchandise Authorization (RMA) request. See Section 1.7.

D.3 Recovering the Main BIOS Block with a USB Device

This feature allows the user to recover the main BIOS image using a USB-attached device without additional utilities used. A USB flash device such as a USB Flash Drive, or a USB CD/DVD ROM/RW device can be used for this purpose. However, a USB Hard Disk drive cannot be used for BIOS recovery at this time.

The file system supported by the recovery block is FAT (including FAT12, FAT16, and FAT32) which is installed on a bootable or non-bootable USB-attached device. However, the BIOS might need several minutes to locate the SUPER.ROM file if the media size becomes too large due to the huge volumes of folders and files stored in the device.

To perform UEFI BIOS recovery using a USB-attached device, follow the instructions below.

1. Using a different machine, copy the "Super.ROM" binary image file into the Root "\" directory of a USB device or a writable CD/DVD.

Note 1: If you cannot locate the "Super.ROM" file in your drive disk, visit our website at www.supermicro.com to download the BIOS package. Extract the BIOS binary image into a USB flash device and rename it "Super.ROM" for the BIOS recovery use.

Note 2: Before recovering the main BIOS image, confirm that the "Super.ROM" binary image file you download is the same version or a close version meant for your motherboard.

2. Insert the USB device that contains the new BIOS image ("Super.ROM") into your USB drive and reset the system when the following screen appears.



3. After locating the healthy BIOS binary image, the system will enter the BIOS Recovery menu as shown below.

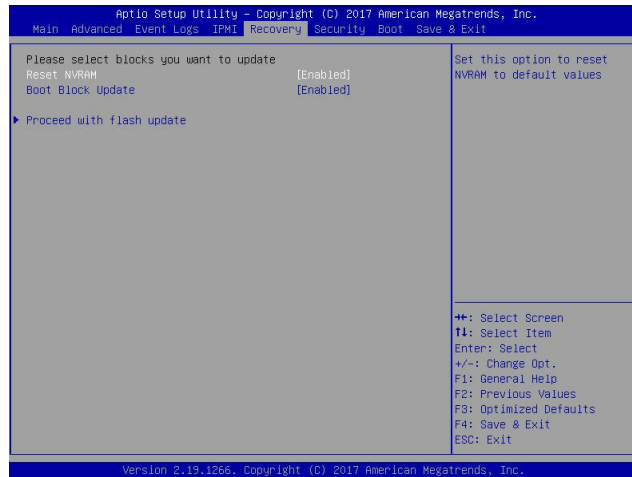

Note: At this point, you may decide if you want to start the BIOS recovery. If you decide to proceed with BIOS recovery, follow the procedures below.

4. When the screen as shown above displays, use the arrow keys to select the item "Proceed with flash update" and press the <Enter> key. You will see the BIOS recovery progress as shown in the screen below.

Note: Do not interrupt the BIOS flashing process until it has completed.

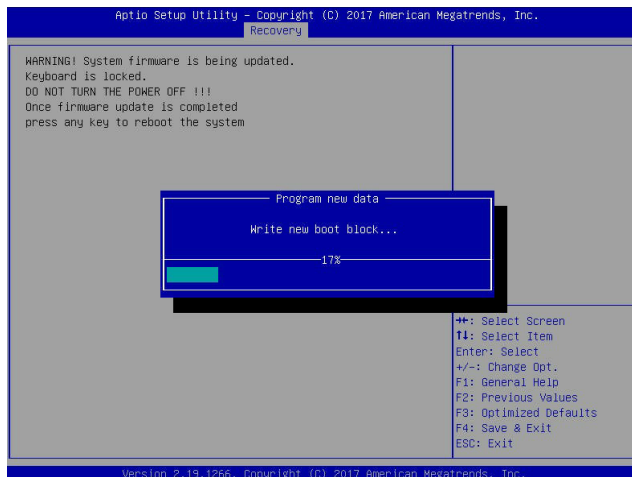

5. After the BIOS recovery process is complete, press any key to reboot the system.

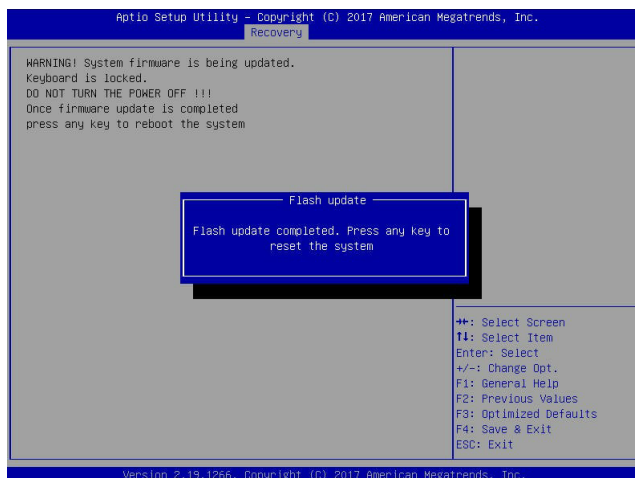

6. Using a different system, extract the BIOS package into a USB flash drive.
7. Press continuously during system boot to enter the BIOS Setup utility. From the top of the tool bar, select Boot to enter the submenu. From the submenu list, select Boot Option #1 as shown below. Then, set Boot Option #1 to [UEFI AP:UEFI: Built-in EFI Shell]. Press <F4> to save the settings and exit the BIOS Setup utility.

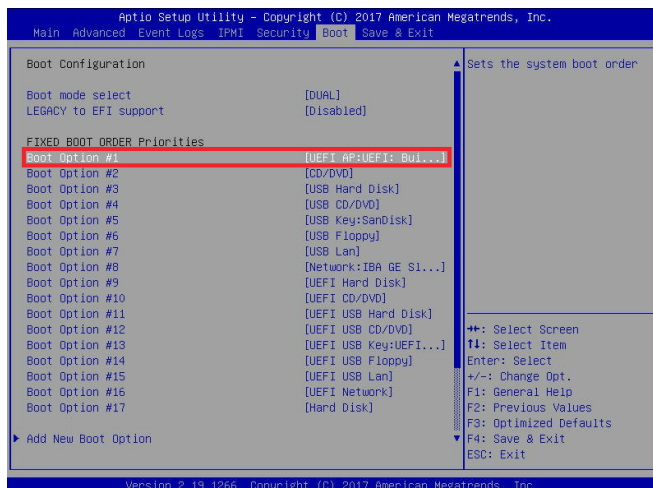

- When the UEFI Shell prompt appears, type `fs#` to change the device directory path. Go to the directory that contains the BIOS package you extracted earlier from Step 6. Enter `flash.nsh BIOSname.###` at the prompt to start the BIOS update process.

```

UEFI Interactive Shell v2.1
EDK II
UEFI v2.50 (American Megatrends, 0x0005000C)
Mapping table
  FS0: Alias(s):HD0:0B:BLK1:
      PciRoot(0x0)/Pci(0x14,0x0)/USB(0x11,0x0)/HD(1,MBR,0x3791072,0x800,0x1
DR959C)
  BLK0: Alias(s):
      PciRoot(0x0)/Pci(0x14,0x0)/USB(0x11,0x0)
Press F8 in 1 seconds to skip startup.nsh or any other key to continue.
Shell: fs0:
FS0:\> cd AFUDOS
FS0:\AFUDOS> cd SNIJPE2_03162017
FS0:\AFUDOS\SNIJPE2_03162017> flash.nsh X110PU7_314
    
```

Note: *Do not interrupt this process* until the BIOS flashing is complete.

```

Done.
[ Access Cmos Port Ex ]
<Read>
Index 0x51: 0x10

Done.
*****
* Program BIOS and ME (including FDT) regions...
*****
| AMT Firmware Update Utility v5.09.01.1917 |
| Copyright (C)2017 American Megatrends Inc. All Rights Reserved. |
-----
CPUID = 50652

Reading flash ..... done
- ME Data Size checking - ok
- FFS checksums ..... ok
- Check RomLayout ..... Ok
Erasing Boot Block ..... done
Updating Boot Block ..... done
Verifying Boot Block ..... done
_Erasing Main Block ..... 0x00132000 (0x)
    
```

- The screen above indicates that the BIOS update process is complete. When you see the screen above, unplug the AC power cable from the power supply, clear CMOS, and plug the AC power cable in the power supply again to power on the system.

```

Verifying NDB Block ..... done
- Update success for FDR
+ Update success for IE
- Successful Update Recovery Loader to OPRx11
- Successful Update MFSB11
- Successful Update FPR11
- Successful Update MFS, IVBI and IVB211
- Successful Update FLOG and UTDK11
- ME Entire Image update success !!
WARNING : System must power-off to have the changes take effect!
Moving FS0:\AFUDOS\SNIJPE2_03162017\Fdtv64.efi -> FS0:\AFUDOS\SNIJPE2_03162017\F
dt1.smc
- [ok]
Moving FS0:\AFUDOS\SNIJPE2_03162017\Fuef1x64.efi -> FS0:\AFUDOS\SNIJPE2_0316201
7\Fuef1.smc
- [ok]
*****
* Please ignore this 'Shell: Cannot read from file - Device Error'
* warning message due to it does not impact flashing process.
*****
Deleting "FS0:\uefiprom"
Delete successful.
FS0:\>
    
```

- Press `` continuously to enter the BIOS Setup utility.
- Press `<F3>` to load the default settings.
- After loading the default settings, press `<F4>` to save the settings and exit the BIOS Setup utility.