



TouchPoint T7 User Manual

Humanscale®
HEALTHCARE

Better Design,
Better Care

HUMANSCALE T7 POINT-OF-CARE TECHNOLOGY CART

This user manual contains information on the installation and operation of Humanscale’s T7 Point-of-Care Technology Cart. It also contains important maintenance information and safety requirements. Read all instructions completely before using the T7.

TABLE OF CONTENTS

Introduction

1.0	About Humanscale Healthcare	3
1.1	Contact Information	3
2.0	Introduction to the T7 Point-of-Care Technology Cart	4
2.1	About This Product - Frequently Used Functions	4
2.2	Cart Features	7
2.3	Technical Data	19
3.0	Using the User Interface	20
3.1	Interference Detection	29
4.0	Glossary of Symbols and Warnings	30
4.1	Cart Warning Review	31

Getting Started

5.0	Unpacking and Preassembly	34
5.1	Unpacking the T7	34
5.2	Mounting a Monitor	35
5.3	Installing a Computer	36

Operation

6.0	Power System Overview	38
6.1	Initial System Startup and Shutdown	38
6.2	Proper Power System Recharging	39
6.3	Battery Level Indicator (BLI)	39
6.4	Shutdown Switch	40
7.0	Adjusting the T7	41
7.1	Tips on Adjusting the T7	41
7.2	Ergonomic Monitor Positioning	41
8.0	Troubleshooting and Frequently Asked Questions	42
9.0	Accessories	43

Technical Information

10.0	Maintenance and Cleaning	47
10.1	Cart Maintenance	47
10.2	Cart Cleaning	48
11.0	Dimensions and Range of Adjustments	49
11.1	Monitor Adjustment Range	55
12.0	Radiated Emissions	56
12.1	Recommended Separated Distances	56
12.2	Guidance and Manufacturer’s Declaration—Emissions	57
12.3	Guidance and Manufacturer’s Declaration—Immunity	58
13.0	Shipping and Operating Environment	60
13.1	Shipping Environment	60
13.2	Operating Environment	60
14.0	System Messages	60

Warranty

15.0	Warranty	61
16.0	FCC Compliance Statement	61

INTRODUCTION



1.0 ABOUT HUMANSCALE HEALTHCARE

Humanscale Healthcare designs and manufactures ergonomic products for easier use of today's technology and creates a safer and more comfortable and efficient environment for the caregiver. As part of the Humanscale Corporation, a world leader in ergonomic design, Humanscale Healthcare brings to the healthcare market a unique understanding of the importance of ergonomics in the workplace.

Humanscale's products for office and healthcare environments are designed to improve the health and quality of work life, and follow the belief that if a design solves a functional problem as simply and elegantly as possible, the resulting form will be timeless. Humanscale Healthcare applies that same design approach to ergonomic solutions that are created to improve the caregiving experience for caregivers and patients alike. Humanscale Healthcare's products include the ViewPoint™ series of technology wall stations and the TouchPoint™ line of mobile technology carts.

For more information about Humanscale Healthcare, please visit www.humanscalehealthcare.com or call 1-800-400-0625.

1.1 CONTACT INFORMATION

Humanscale Corporation

5675 DTC Boulevard

Suite 100

Greenwood Village, CO 80111

+1-800-400-0625

North America Customer Support: hcorders@humanscale.com

International Customer Support: [intlhcorders@humanscale.com](mailto:intlhorders@humanscale.com)

Website: www.humanscale.com

2.0 INTRODUCTION TO THE T7™ POINT-OF-CARE TECHNOLOGY CART

Built with the caregiver's work flow in mind, the T7—part of the revolutionary TouchPoint line of mobile technology carts—addresses the challenges faced by existing medical carts by offering optimal ergonomic positioning with minimal (and often automatic) adjustments. To reduce the risk of injuries and change the way caregivers interact with point-of-care technology, the T7 provides simple, quick adjustments that encourage medical caregivers to work in safe postures. And its compact footprint makes the T7 easy to maneuver and prevents parts from sticking out and breaking. Accommodating PCs, tablets and laptops, the T7 facilitates mobile computing in healthcare environments. Humanscale, the world's premier ergonomic solutions manufacturer, engineered the T7 to be the new industry standard in cart technology.

2.1 ABOUT THIS PRODUCT - FREQUENTLY USED FUNCTIONS

To meet the ergonomic requirements of the vast majority of users in sitting or standing postures, the T7's Auto Fit™ technology adjusts the unit to the caregiver's entered height with minimal effort. By eliminating all but one adjustment step and allowing users to enter their own specific heights, the T7 encourages users to work in an optimized ergonomic position.

Further exemplifying the T7's sophisticated design is its Power Track™ steering, which enables caregivers to easily maneuver in tight spaces and corridors, even with one-hand operation. And, due to its low center of gravity and centralized mass, the T7 has excellent balance and stability for smoother, safer use. As a result, the T7 offers industry-leading maneuverability and one of the smallest practical footprints on the market.

In addition, the digital interface, keyboard and mouse on the T7 are within the shoulder width—and therefore the ergonomic range—of the user.

The T7 also offers two different tilting monitor-arm options, both of which accommodate a vast range of individuals, including those with bifocals.

For expanded utility, the T7 offers additional storage options such as MedLink, MedProx or standard utility drawers.

Engineered for lasting use, the T7 has a flexible power system with either an SLA or a lithium battery. In addition, the power system and battery are readily accessible for easy maintenance by a trained Humanscale technician.

The T7 has a completely encased wire management system, which mitigates both clutter and infection-control concerns. In any setting, the T7's streamlined design makes cleaning easy and promotes a healing environment. The construction of the T7 consists primarily of durable aluminum, with steel and plastic components.

POWERED CART CONFIGURATIONS

The Powered T7 is configured with an electronic lifting system and touch screen interface. The Battery-Powered model has an onboard rechargeable power system that can supply power to the CPU, monitor and other peripheral devices.

The T7 utilizes internal routing of power cables to make the cart easy to operate. Access to the internal AC output (Tripletap) is used for computer power, monitor power, and any AC peripherals located under the technology cover (facing the front of the cart it will be the right hand side of work surface. Facing the rear of the cart it will be the left hand side of the work surface.



T7 Powered Cart
PC, Adjustable Monitor
Mount (UFEA), Fixed
Keyboard Tray



T7 Powered Cart
PC, Fixed Monitor
Arm, Fixed
Keyboard Tray

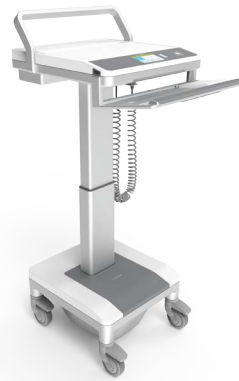

T7 Powered Cart
Laptop,
Fixed Keyboard Tray



T7 Powered Cart
PC, Fixed Monitor Arm,
Articulating
Keyboard Tray

NON-POWERED CART CONFIGURATIONS

Although the Non-Powered T7 does not have an electronic lifting system, it can still utilize an external plug, keeping all computer wires within the unit. To use the Non-Powered T7, connect the supplied AC power cord to the power inlet underneath the work surface and a hospital-grade power outlet.

The Non-Powered T7 cannot be converted to a Battery-Powered T7.



T7 Non-Powered Cart
PC, Adjustable Monitor
Mount (UFEA), Fixed
Keyboard Tray



T7 Non-Powered Cart
PC, Fixed Monitor
Arm, Fixed
Keyboard Tray

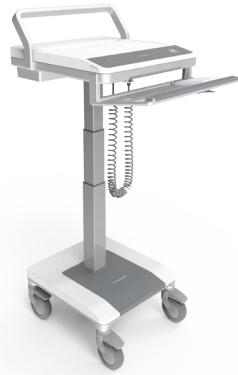

T7 Non-Powered Cart
Laptop, Fixed
Keyboard Tray



T7 Non-Powered Cart
PC, Fixed Monitor Arm,
Articulating
Keyboard Tray

2.2 CART FEATURES

Humanscale's T7 point-of-care mobile technology cart offers unprecedented ease of adjustment for each user in a shared work environment, providing one, simple, combined adjustment for the work surface, keyboard support and display. The T7's 20" (50.8 cm) height range ensures comfortable ergonomic accommodation for seated and standing workers. (See Section 7.0 Adjusting the T7, page 41)

Features:

1. **Auto Fit Technology (height adjustment):** The T7 features Auto Fit technology accessible via a digital dashboard interface. Anthropometric data determines the eye levels and elbow heights associated with certain overall heights of users. As such, the T7's monitor and work surface/keyboard are designed to adjust to the ergonomically optimal eye and elbow level for each user according to the overall height each user enters in the digital dashboard interface.
2. **Keyboard Supports:** The standard and recommended keyboard support is fixed at a negative title angle so that the user's wrist is kept in a straight line to the elbow when the work surface has been ergonomically adjusted for the user's height, and, as such, encourages ergonomically safe positions that help prevent such musculoskeletal disorders as carpal tunnel syndrome. For tight patient room spaces and environments, we do offer our award winning adjustable Keyboard Trays as an option.
3. **Handle/Palm Rest:** Acting as a palm rest for the keyboard, the handle also features the Power Track steering button on its underside.
4. **Mouse Position:** Two options for fixed mouse platform are available, both of which keep the mouse within the footprint of the cart and maximize ergonomic positioning.
5. **Gantry:** Serving as a back handle for the cart and as cable management, the gantry raises the monitor support above the work surface, providing more work surface while guiding the cart.
6. **Large, Clean Work Surface:** Ample work surface space allows for greater utility.
7. **Stride and Toe Clearance:** Positioning of the keyboard platform allows the handle to be far enough from the base of the cart to leave room for full strides and toe clearance when walking.
8. **Power Track Steering:** Increasing control, the Power Track Steering directs the weight of the cart and aids the user in moving it in the intended direction. To engage the system, users must simply press the button on the underside of the palm rest.
9. **PC and Laptop Accommodation:** The T7 can support all-in-ones, laptops, thin clients and small form factor PCs, based on various mounting options available.
10. **Screen Moving with Work Surface to Correct Position:** Since the monitor is constrained to the work surface, it moves up and down as the work surface is raised and lowered.
11. **Screen Can Be Moved by User to Desired Position:** The monitor on select models can also be raised and lowered independent of the work surface, to account for people with varying torso lengths. The user can adjust the height of the monitor as desired.

2.2 CART FEATURES

Features (cont'd):

12. **Moving Screen for Bifocal Use:** All models include the possibility for the user to tilt the monitor to help accommodate the use of bifocals.
13. **Monitor Arm:** Provides 15 degrees of tilt and rotates 90 degrees for viewing access and sharing content with patients.
14. **Charging USB:** Ordered as an option, you can add a Charging USB port to fast charge phones, tablets and other peripherals (2.4A). The USB Charging port is conveniently located on the left hand side of the work surface area.
15. **Tap-n-go Ready:** Ordered as an option, standard RFID Readers can be embedded under the work surface (right hand side of the dash board) to optimize Single Sign On capabilities. Option includes mounting feature under work surface and Tap-n-Go logo on overlay as a visual feature.

T7 POWERED CART | PC, Adjustable Monitor Mount (UFEA), Fixed Keyboard Tray

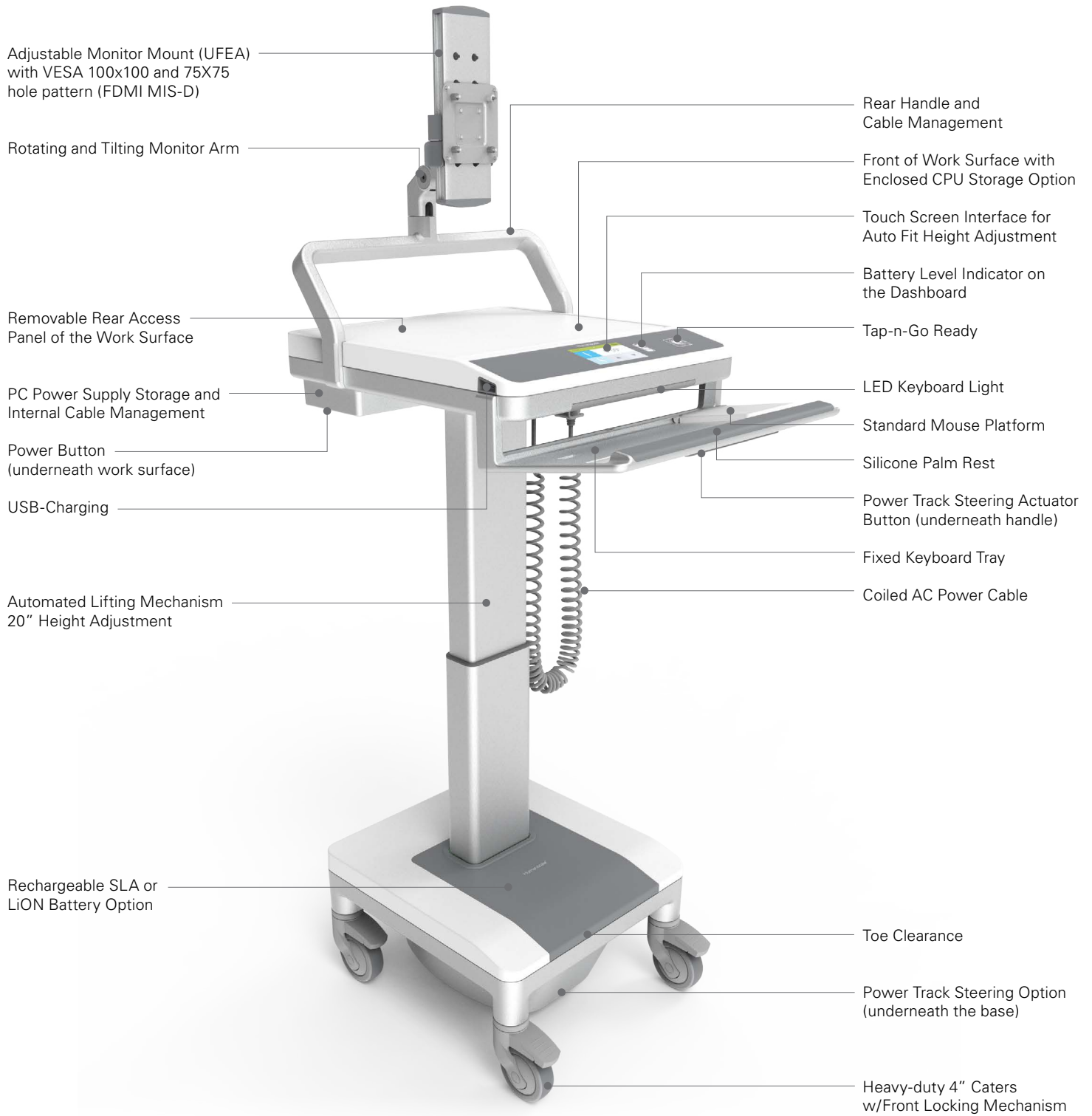

T7 POWERED CART | PC, Fixed Monitor Mount, Fixed Keyboard Tray

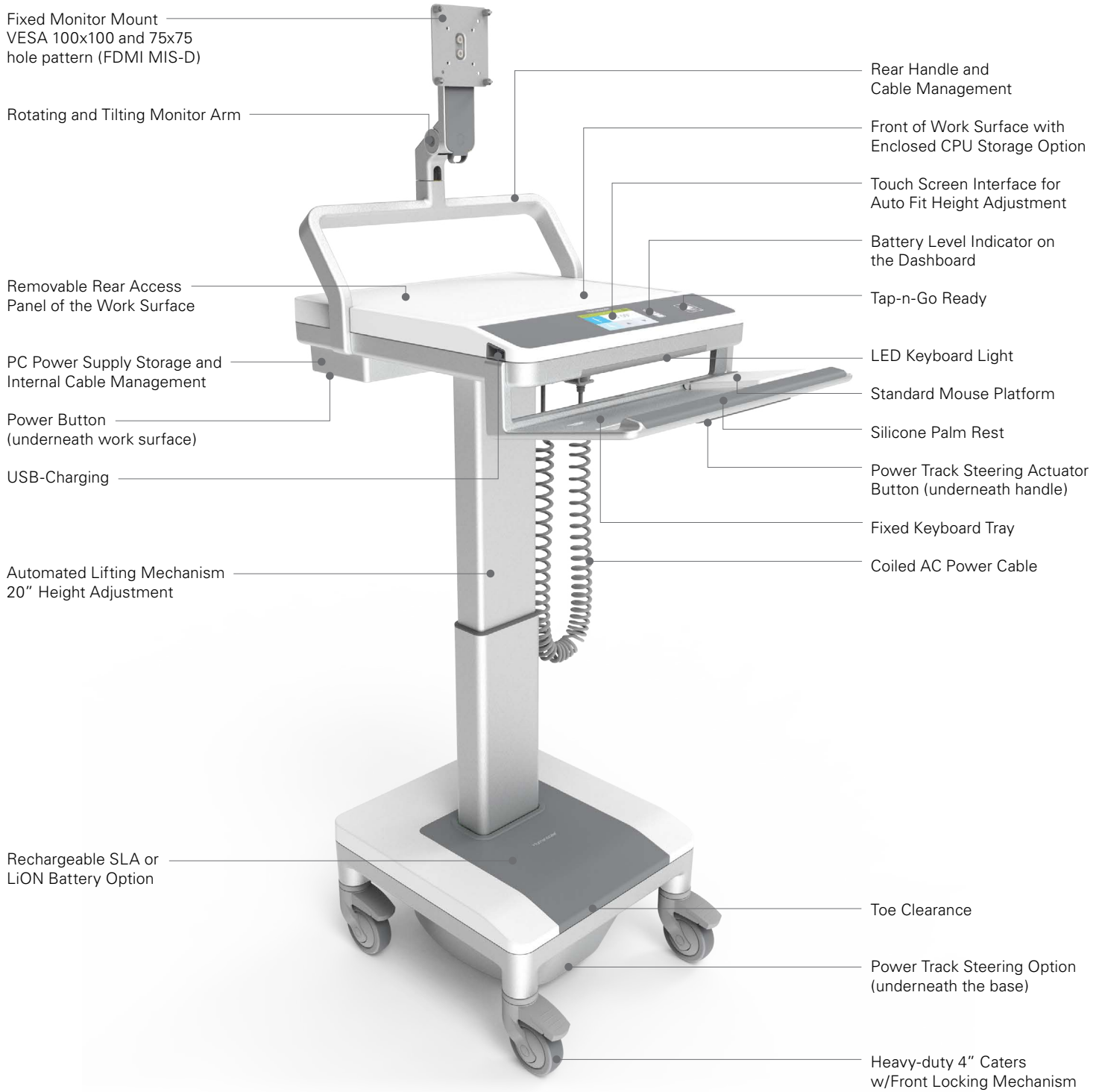

T7 POWERED CART | Laptop, Fixed Keyboard Tray

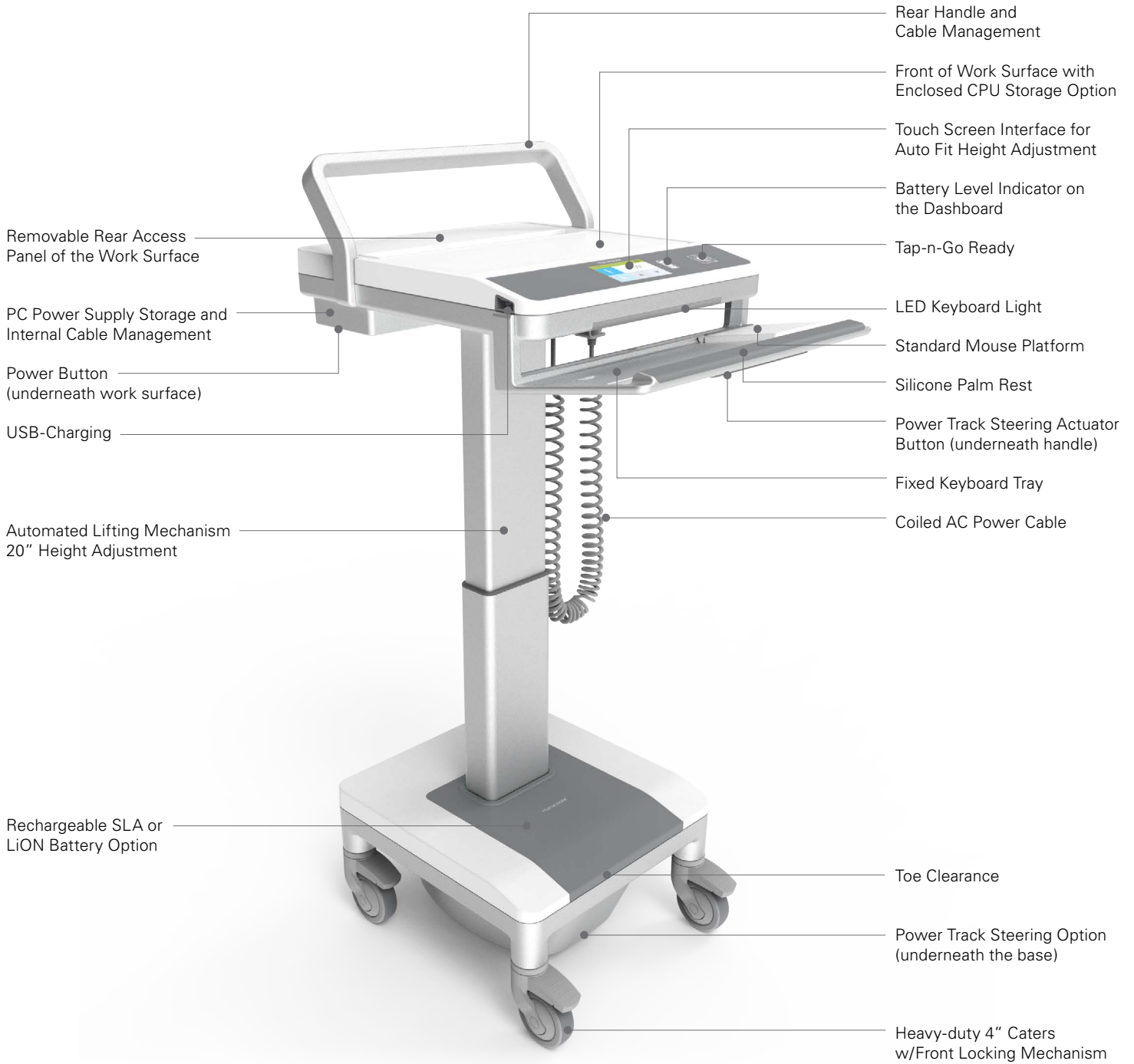

T7 POWERED CART | PC, Fixed Monitor Mount, Articulating Keyboard Tray

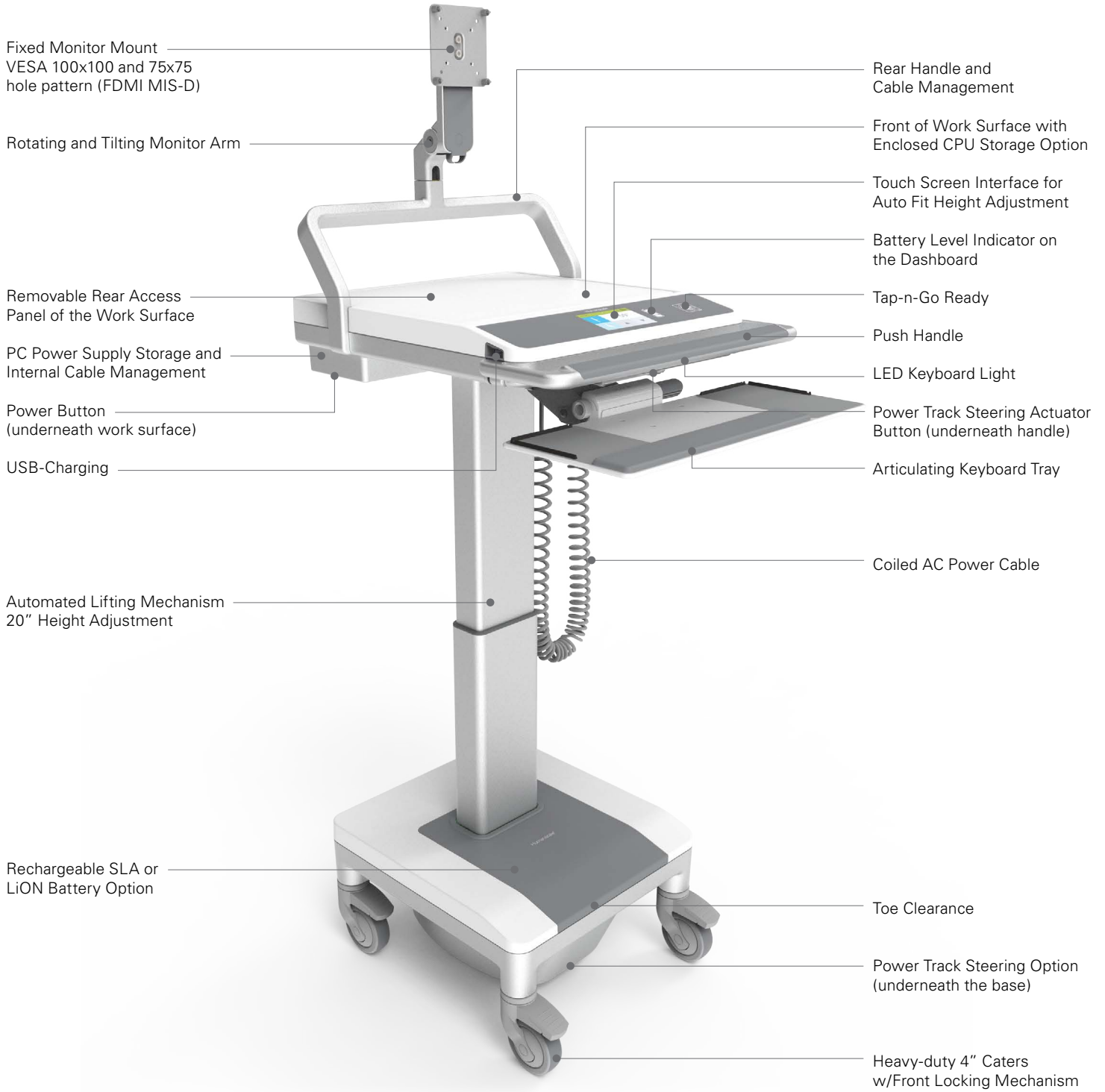

Fixed Monitor Mount
VESA 100x100 and 75x75
hole pattern (FDMI MIS-D)

Rotating and Tilting Monitor Arm

Removable Rear Access
Panel of the Work Surface

PC Power Supply Storage and
Internal Cable Management

Power Button
(underneath work surface)

USB-Charging

Automated Lifting Mechanism
20" Height Adjustment

Rechargeable SLA or
LiON Battery Option

Rear Handle and
Cable Management

Front of Work Surface with
Enclosed CPU Storage Option

Touch Screen Interface for
Auto Fit Height Adjustment

Battery Level Indicator on
the Dashboard

Tap-n-Go Ready

Push Handle

LED Keyboard Light

Power Track Steering Actuator
Button (underneath handle)

Articulating Keyboard Tray

Coiled AC Power Cable

Toe Clearance

Power Track Steering Option
(underneath the base)

Heavy-duty 4" Casters
w/Front Locking Mechanism

T7 NON-POWERED CART | PC, Adjustable Monitor Mount (UFEA), Fixed Keyboard Tray

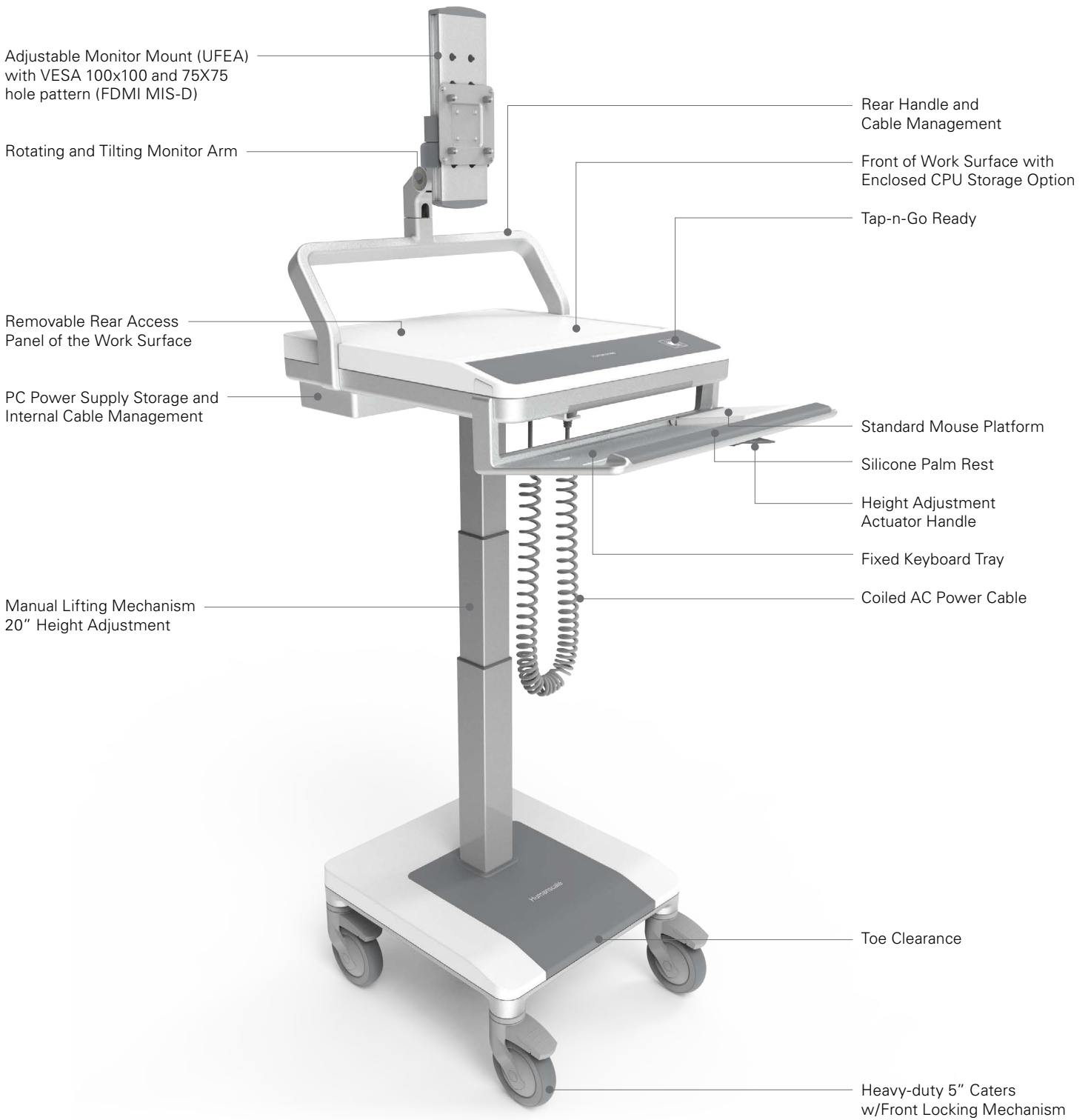

T7 NON-POWERED CART | PC, Fixed Monitor Mount, Fixed Keyboard Tray

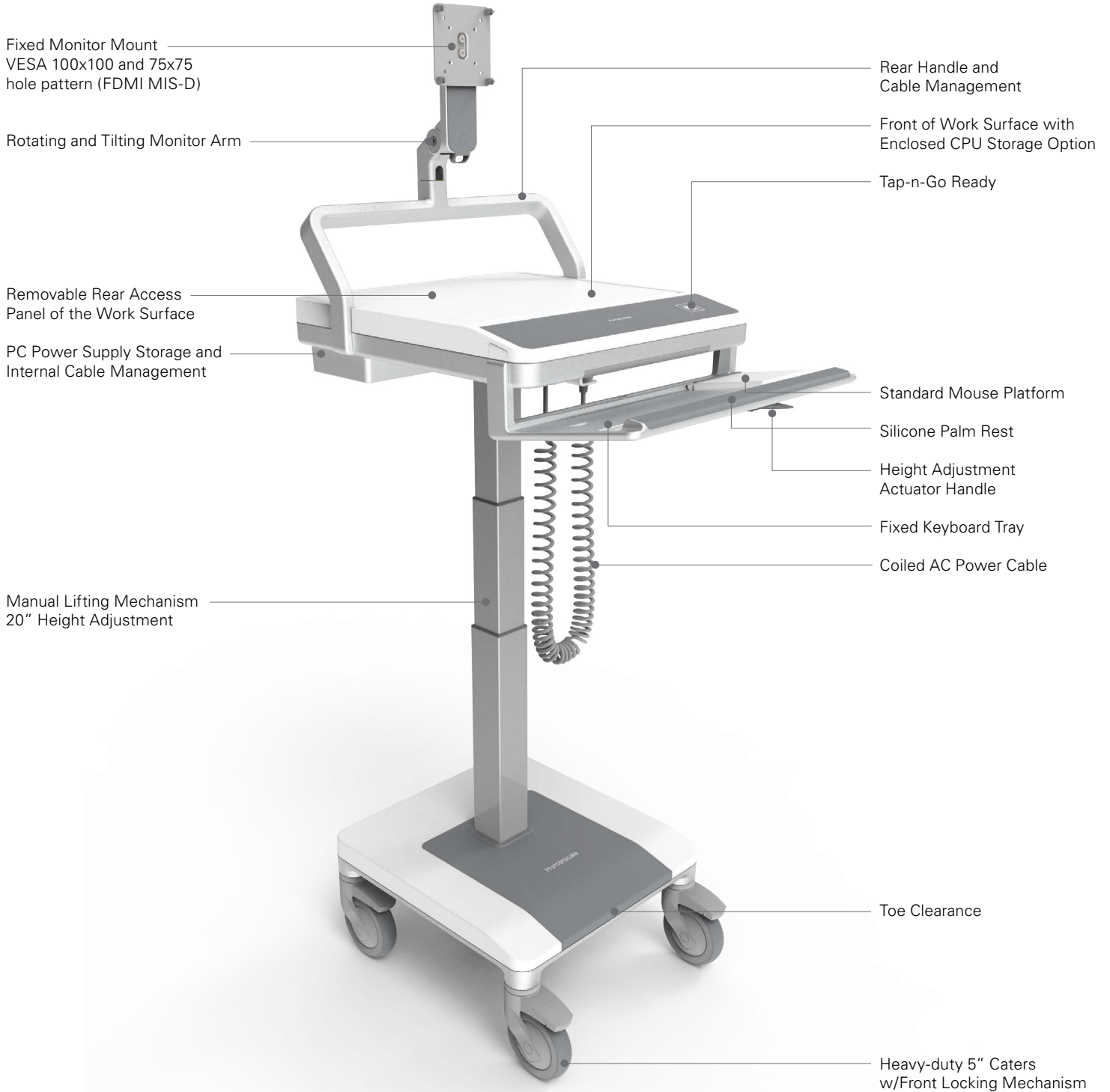

T7 NON-POWERED CART | Laptop, Fixed Keyboard Tray

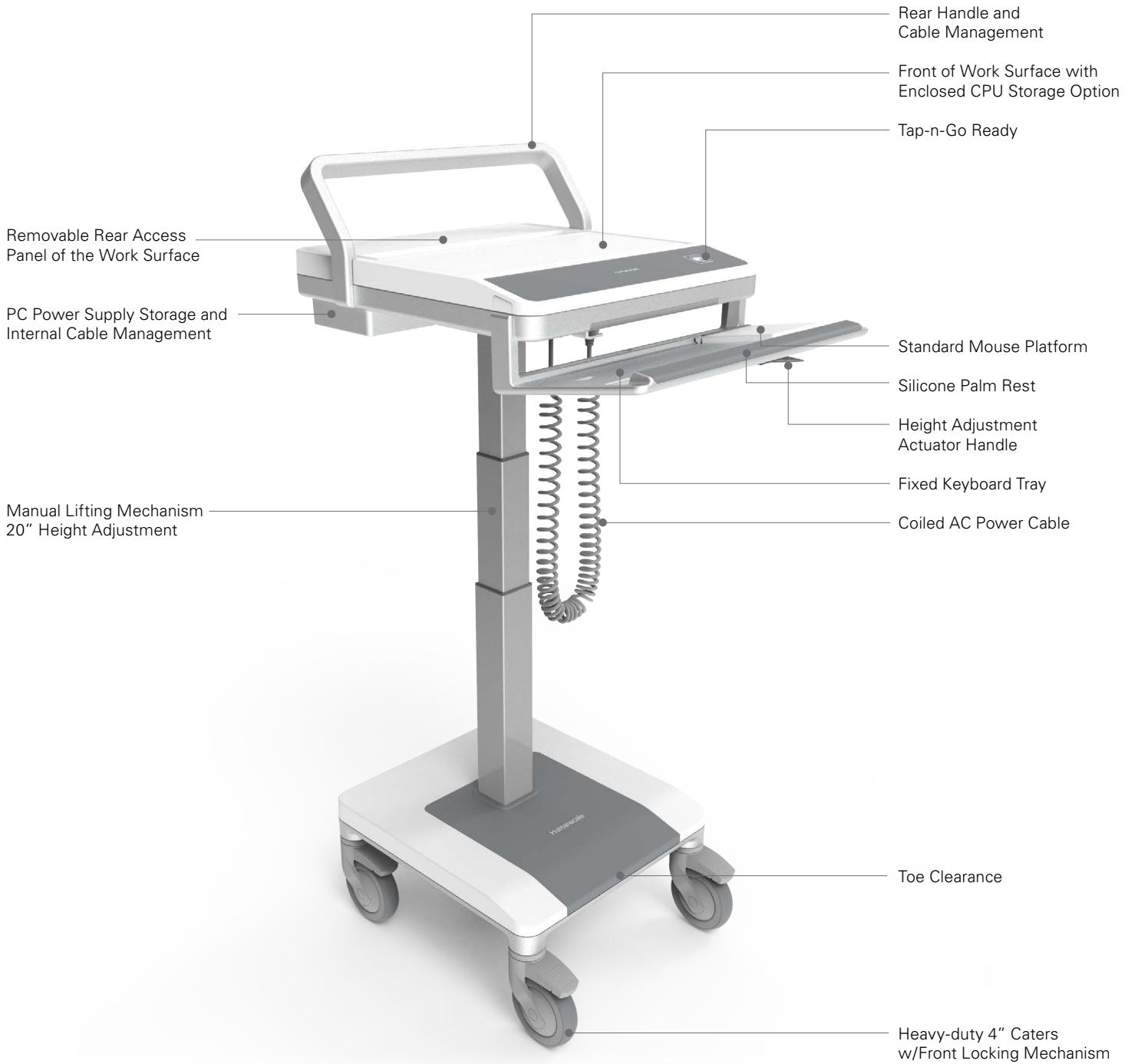

T7 NON-POWERED CART | PC, Fixed Monitor Mount, Articulating Keyboard Tray

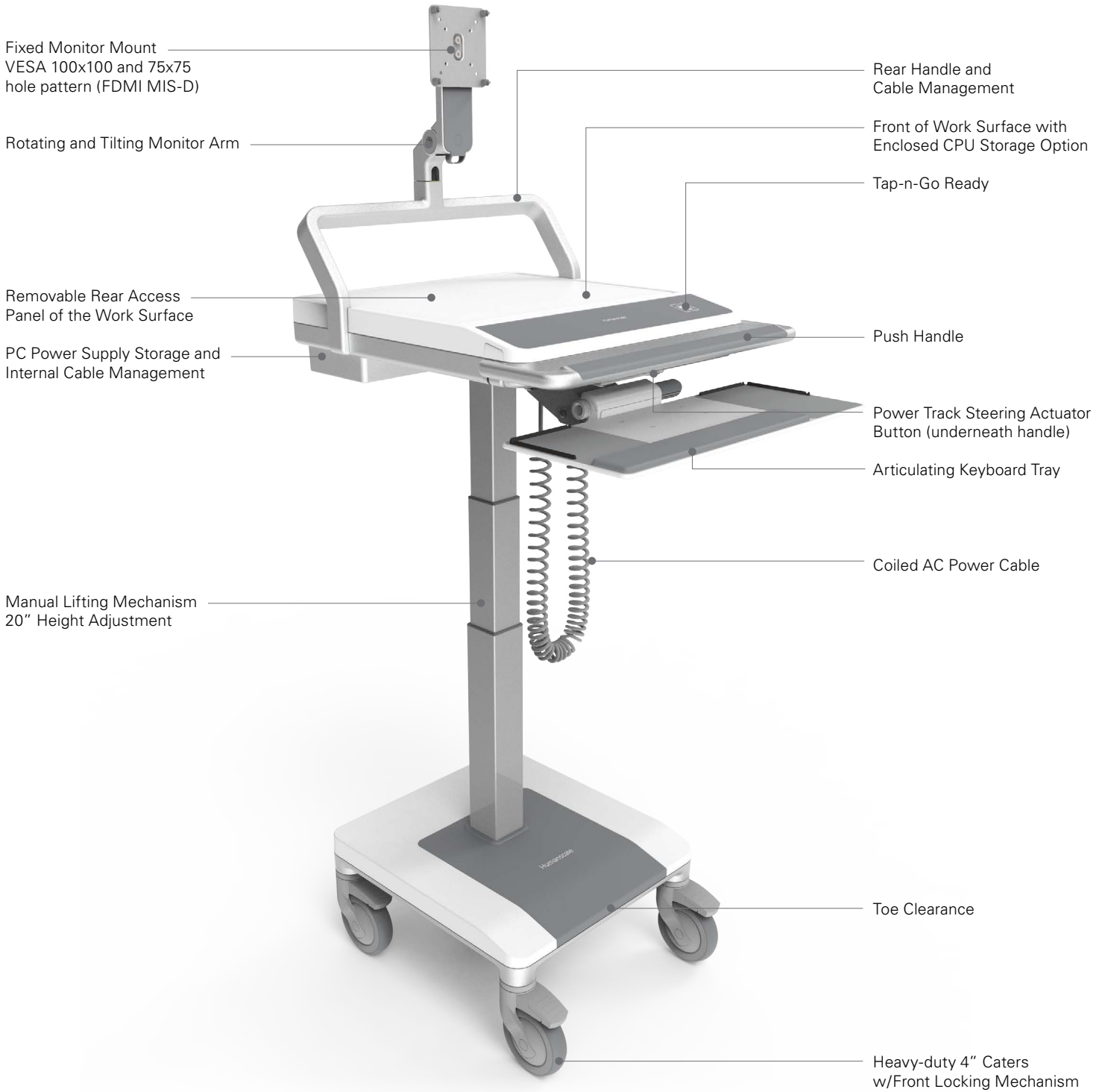

Removable Rear Access Panel of the Work Surface (all models)

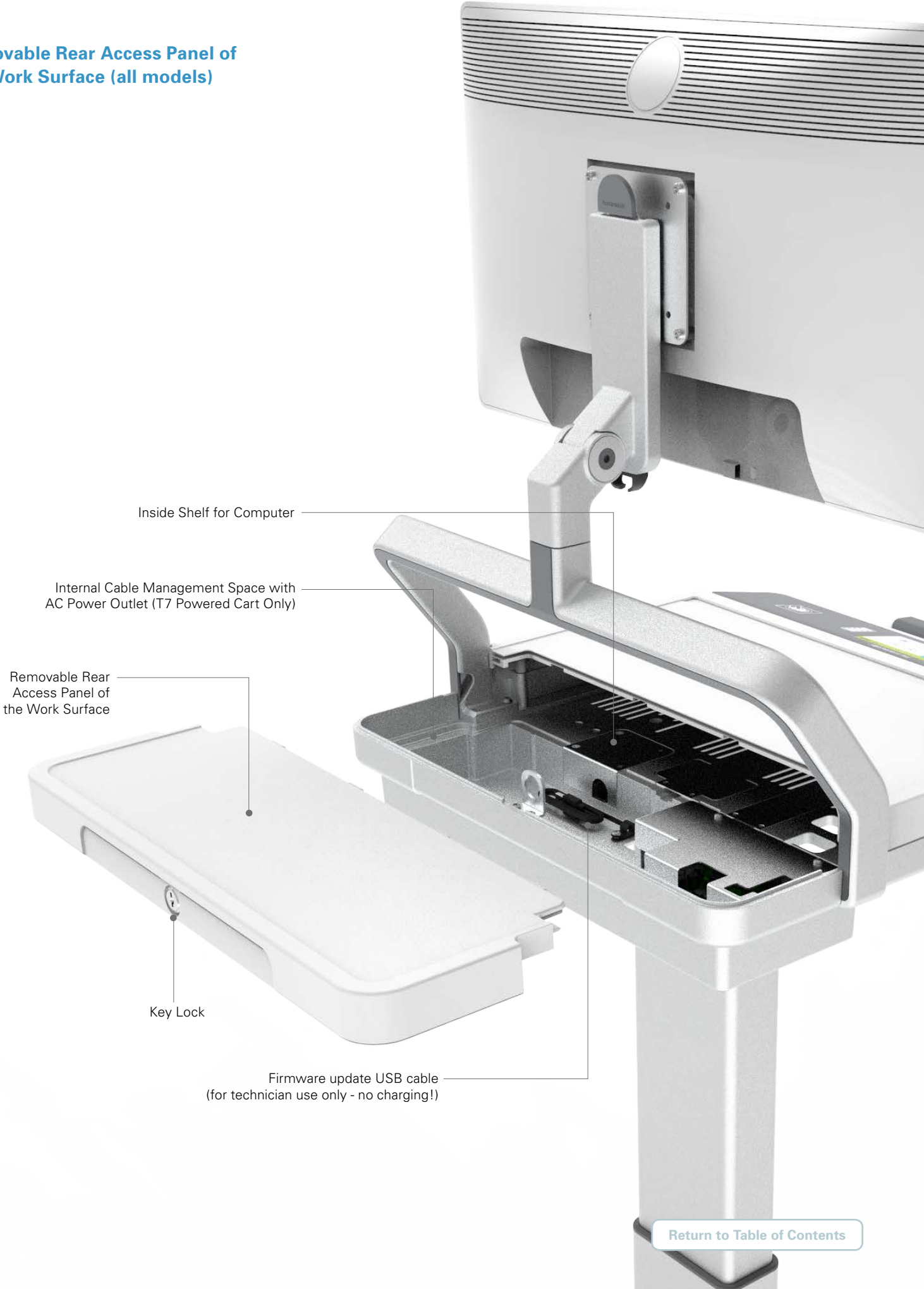

Inside Shelf for Computer

Internal Cable Management Space with AC Power Outlet (T7 Powered Cart Only)

Removable Rear Access Panel of the Work Surface

Key Lock

Firmware update USB cable (for technician use only - no charging!)

T7 Head Assembly (all powered models)

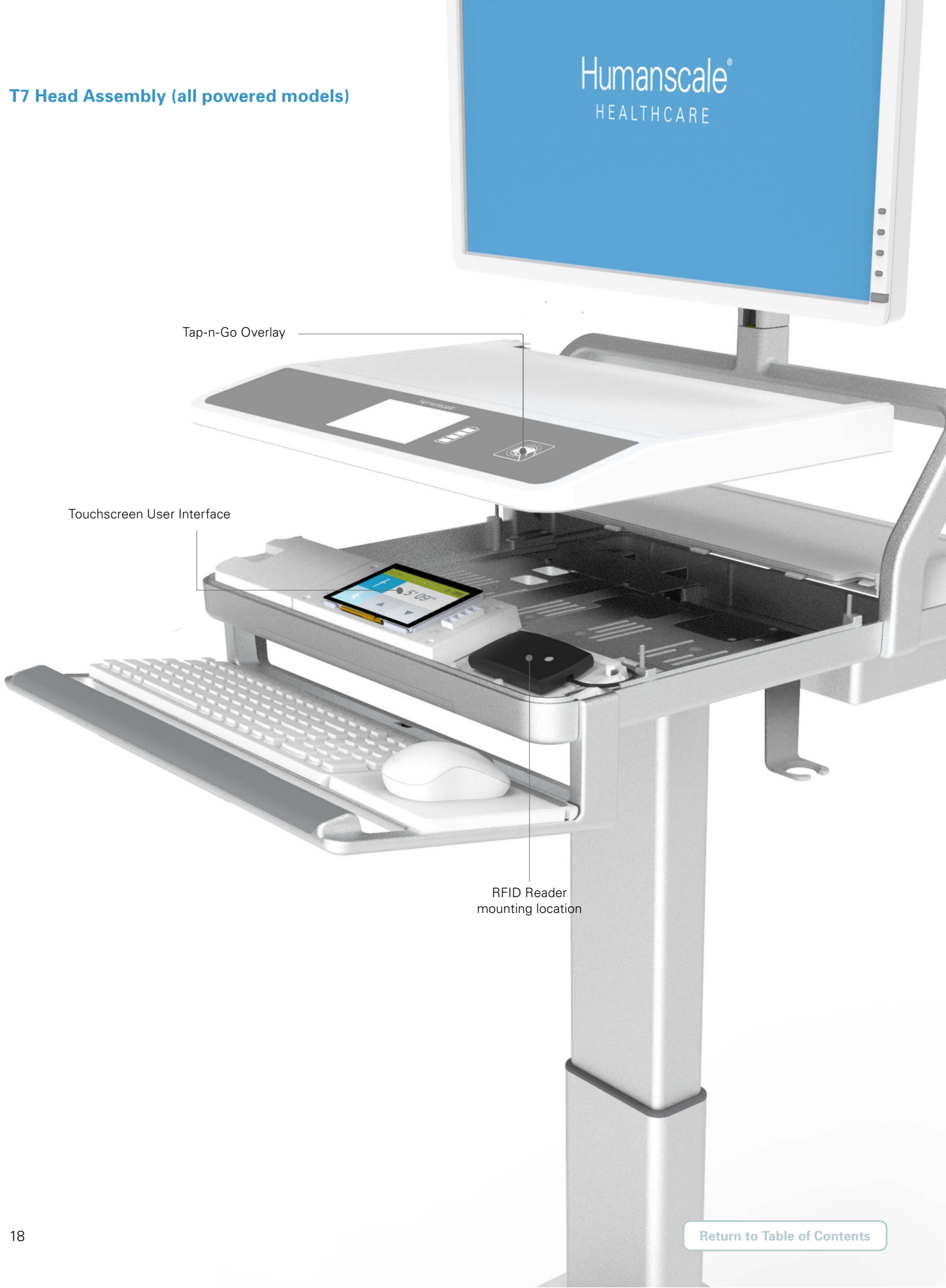

Tap-n-Go Overlay

Touchscreen User Interface

RFID Reader
mounting location

Work Surface Bottom View

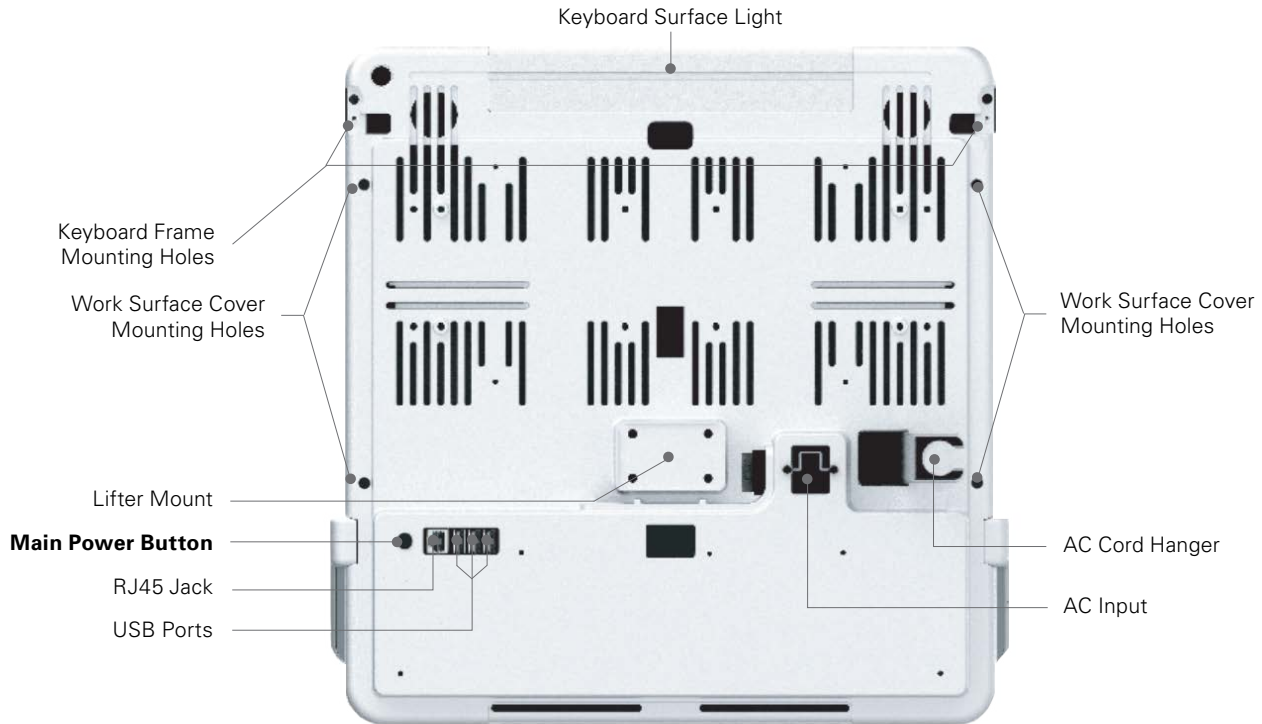

USB/ RJ45 Ports are specifically for the connection and use of the following components:

- Barcode Scanner
- Document Scanner
- External PC
- USB Hub
- Mouse
- Blood Pressure Monitors
- Printer
- Humanscale Branded Accessories

2.3 TECHNICAL DATA

AC Power System

- 120VAC version
 - Input: 120VAC
 - Output: 120VAC pure sine wave, 60Hz
 - Continuous output capacity: 150W
 - Peak output capacity: 225W
- 230VAC version
 - Input: 230VAC
 - Output: 230VAC pure sine wave, 50Hz
 - Continuous output capacity: 150W
 - Peak output capacity: 225W

Battery

- Sealed Lead Acid (SLA)
 - 480 W (35 Amp Hour), 12 V output
- Lithium Iron Phosphate
 - 45 amp hour
 - 12.8 V output
 - 2,000 cycles at 80% depth of discharge (DOD)
 - 2½ hours recharge time
 - Limited 5-year warranty

Battery Level Indicator (BLI)

- Indicates charging status
- Battery level

Recommended Height Adjustment Operation

- 10% Maximum Duty Cycle, 2 minute ON, 18 min OFF

Flat-Panel Display

- **Gantry** can accommodate accessories weighing up to 11.5kg (25lbs) such as but not limited to flat-panel (1 or 2) displays, scanners, bottles, etc.

Computer Dimensions

- The T7 work surface can accommodate a computer up to (L x W x H) 17.35" x 12.3" x 2.25" (440 mm x 312.5 mm x 57 mm) and has a 16.8" (426 mm) wide opening for a laptop screen.

3.0 USING THE USER INTERFACE

Adjusting Height

(User height range: 4' 11" - 6' 03" or 152 cm - 190 cm)

Manual height adjustment screen

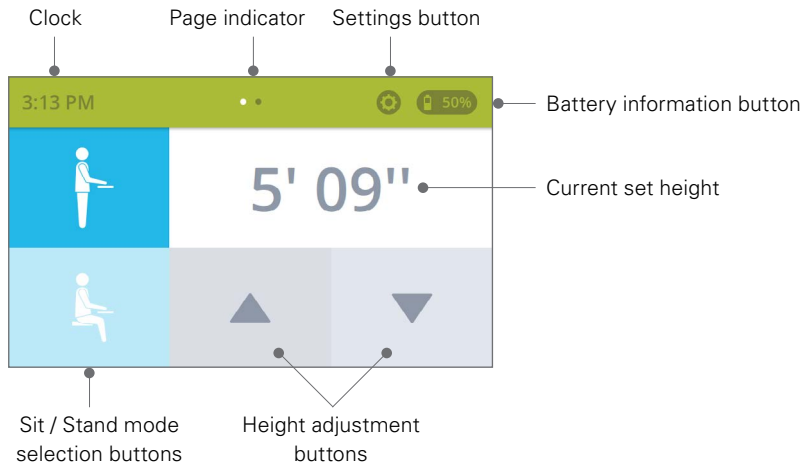

Manual height input

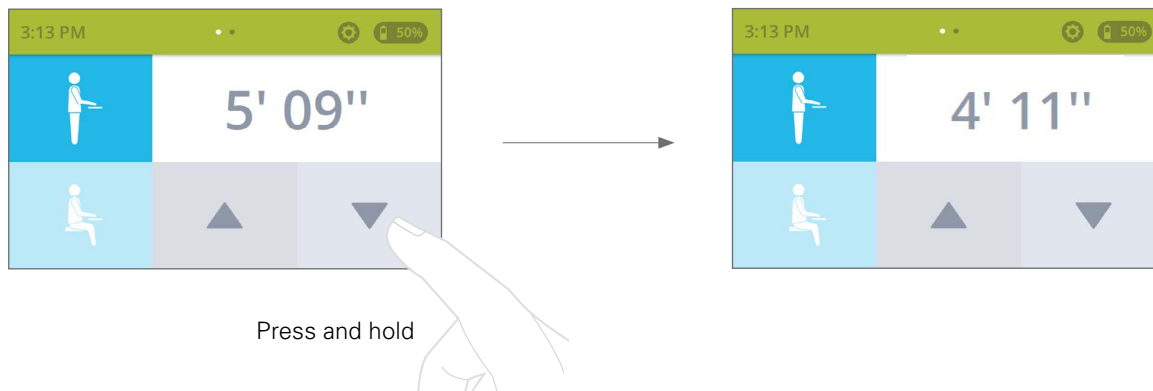

Switching Between Standing And Sitting Position

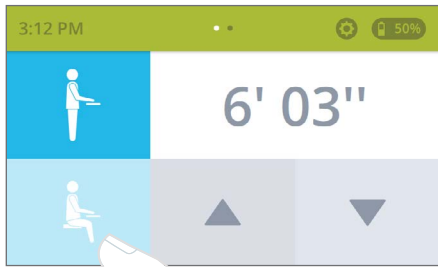

Press

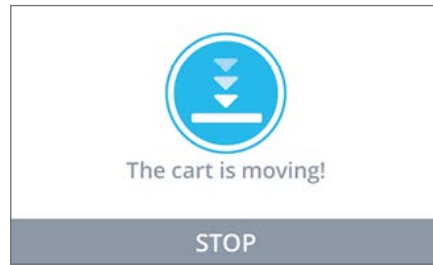

"The cart is moving!" screen is displayed while cart is changing between Sitting and Standing mode.

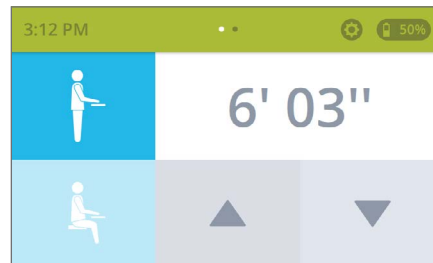

Preset Height Adjustment

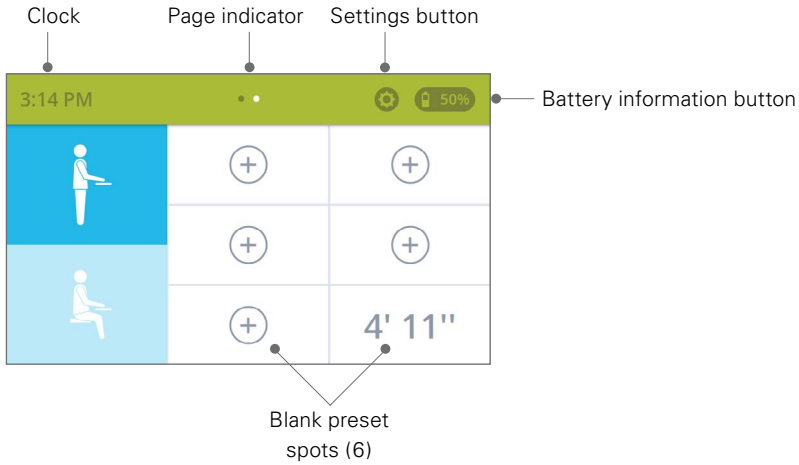

Adding a Preset

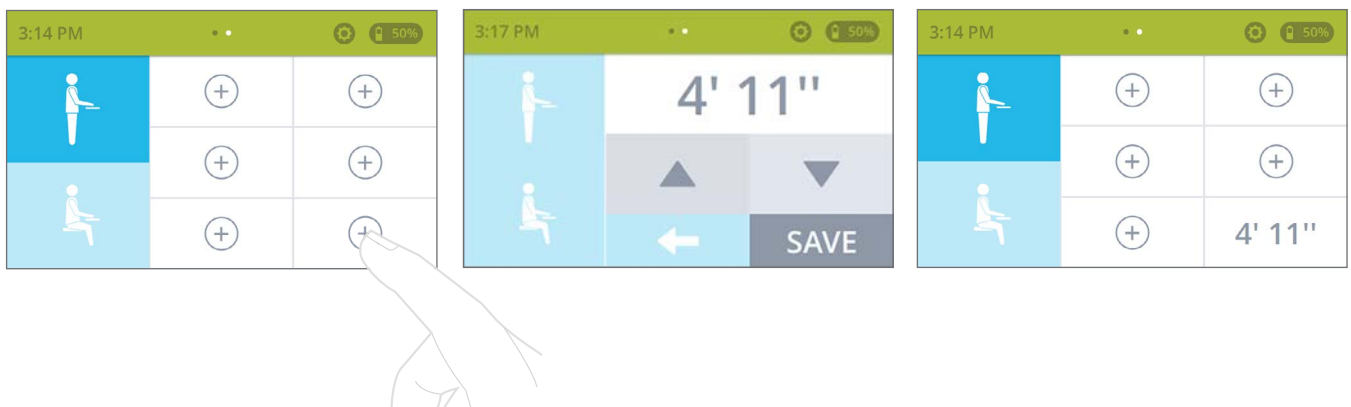

Modifying a Preset

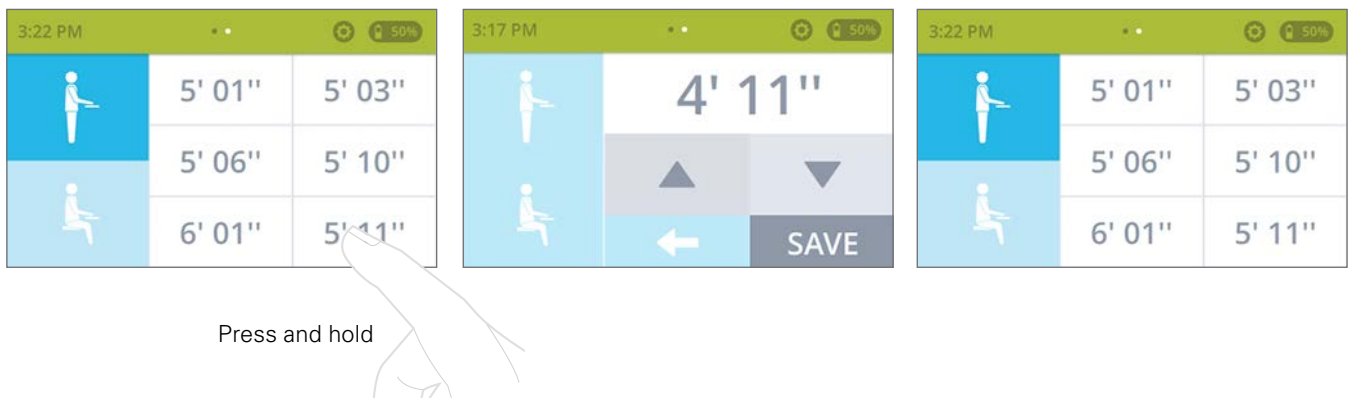

Adjusting Cart Height Using Preset

Changing Cart Height in Standing or Sitting Position

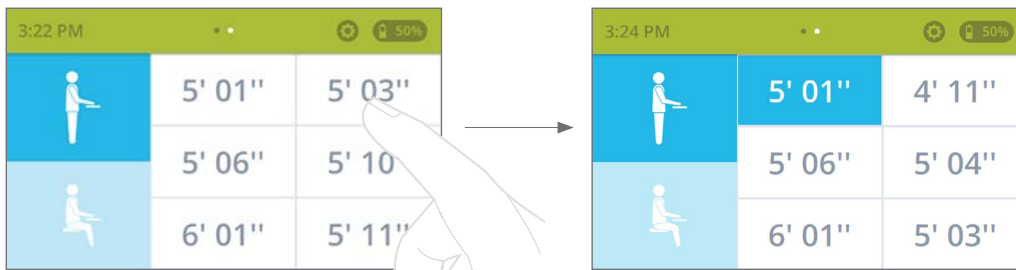

Switching between standing and sitting position using preset

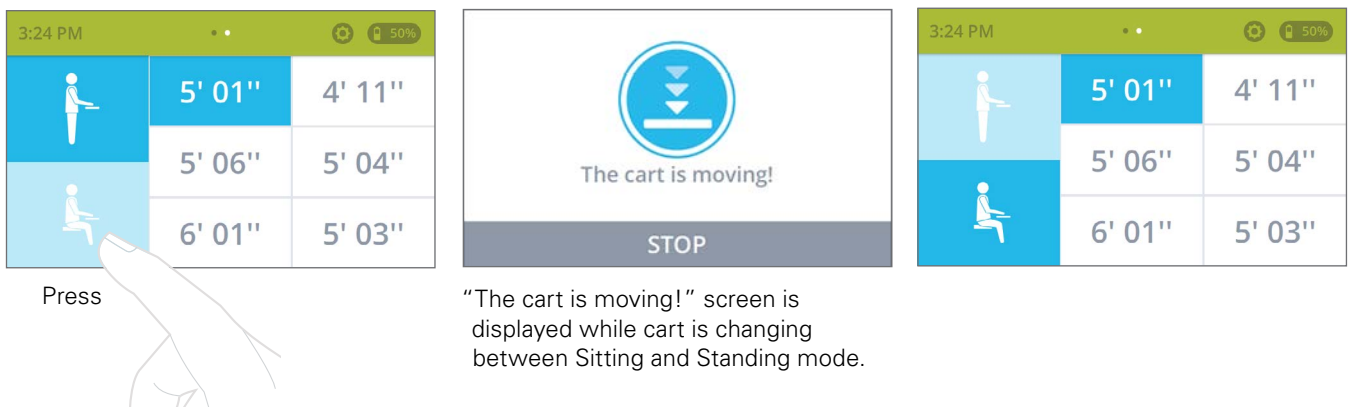

Switching between manual and preset modes

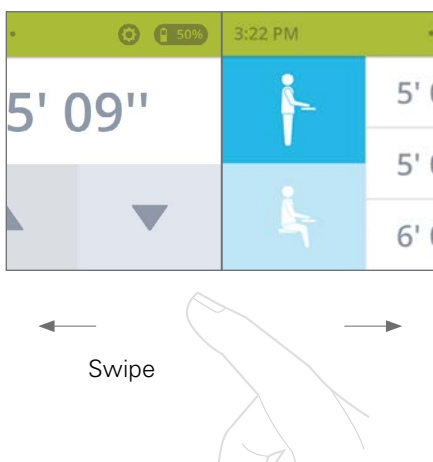

Stopping the Cart Height Adjustment

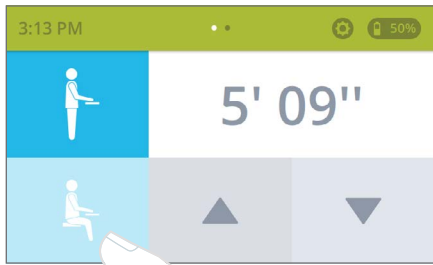

Press

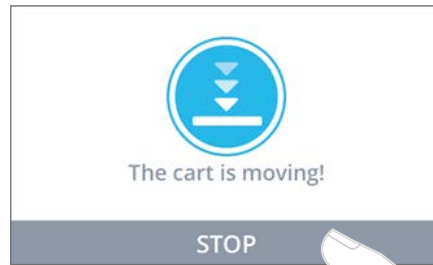

Press

Stopping the Cart's Movement

Stopping the adjustment - preset mode



Press

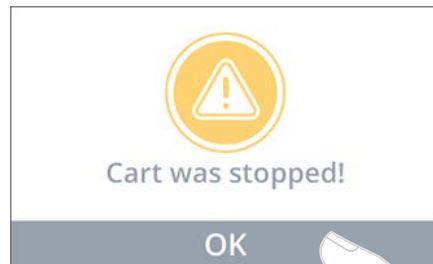

Press

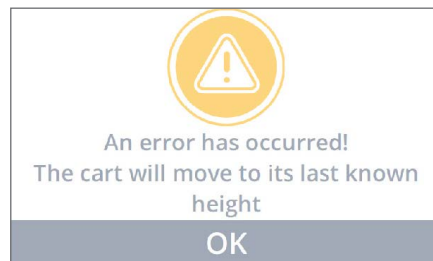

Settings

Getting into User Settings from Manual and Preset Mode

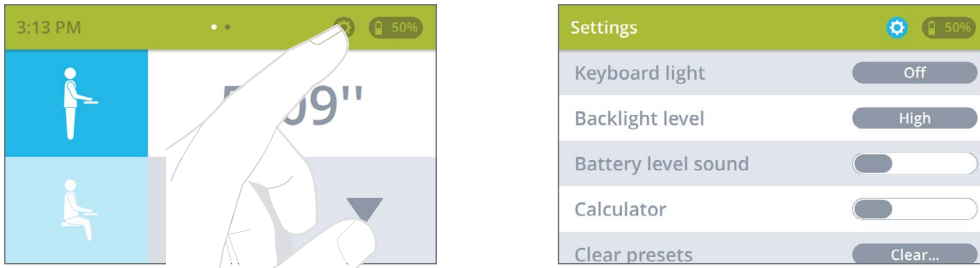

Getting into Admin Settings from User Settings

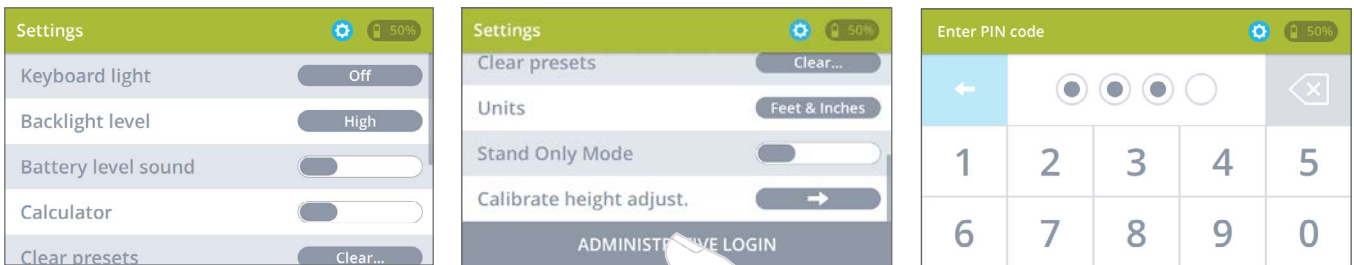

Scroll down to the bottom of the User Settings list

Press

Enter PIN to get into Admin Settings
Default Pin: 1234

Changing setting display location between User settings and Admin settings



Press

Selecting check button the setting will appear in User settings.

Back button returns to User Settings

Exit Settings

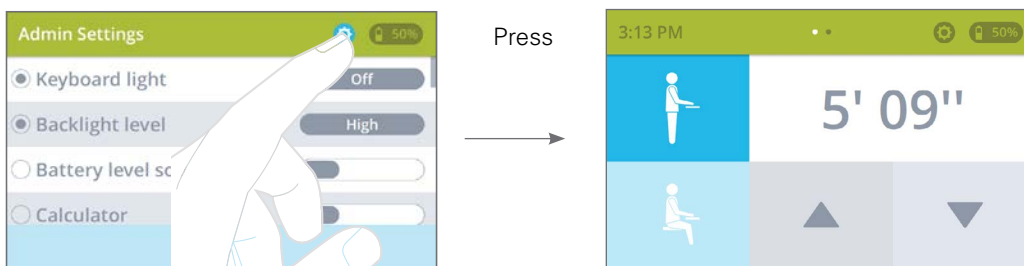

Battery Information

Getting into Battery information from manual and preset mode



Press

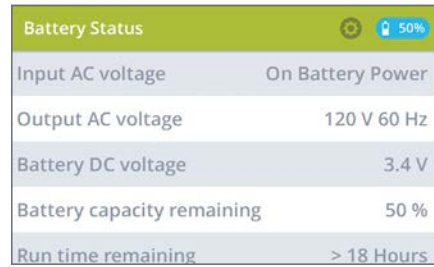

Battery Status	
Input AC voltage	On Battery Power
Output AC voltage	120 V 60 Hz
Battery DC voltage	3.4 V
Battery capacity remaining	50 %
Run time remaining	> 18 Hours

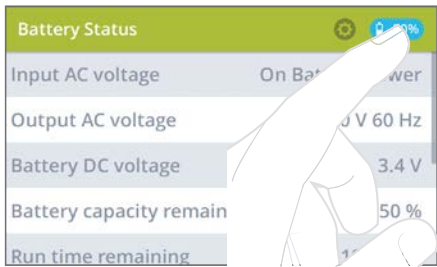

Press

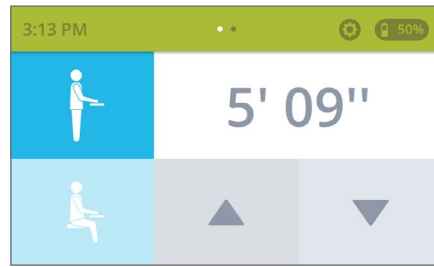

Power Track Is Activated Screen

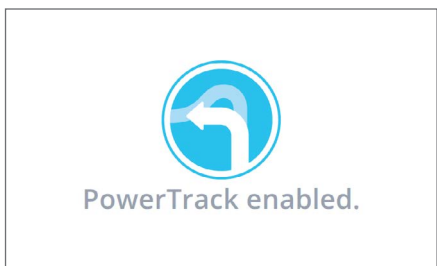

Calculator

Enabling Calculator

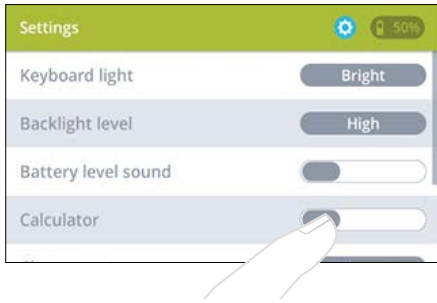

Disabled

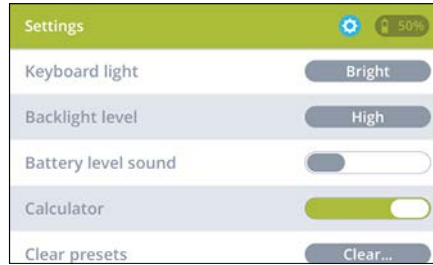

Enabled



Calculator



Cart Labeling

Enabling Cart Labeling

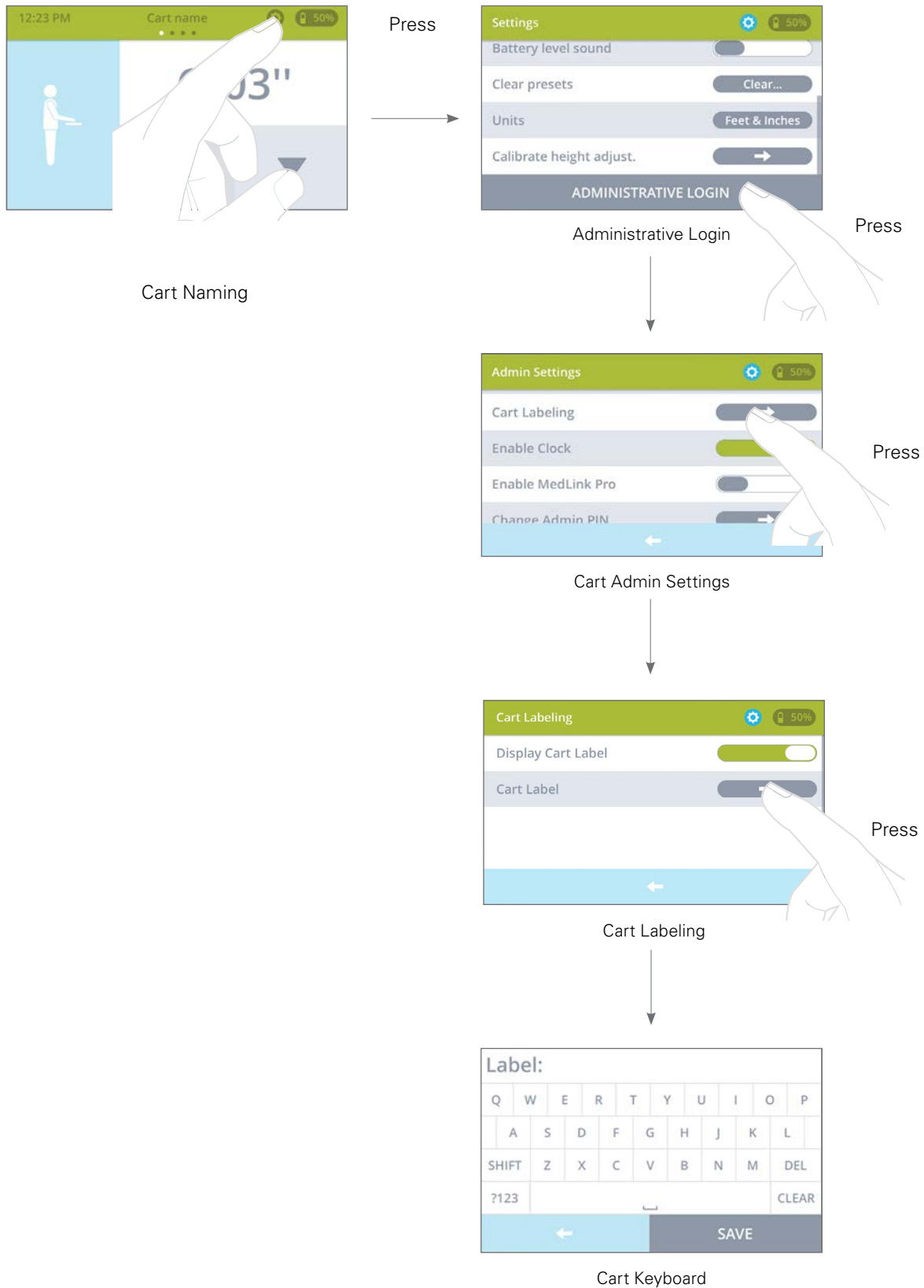

3.1 INTERFERENCE DETECTION

Collision Detection

All T7 powered carts are equipped with a Collision Detection feature, which can limit material damages to a hard object or surface, should a collision occur.

Situations in which the anti-collision function does not work

There are situations in which the anti-collision function will not be activated.

These situations are:

- If the collision happens during the initialization phase
- If the collision happens within the first 1,000 msec or after the control button has been released
- If the collision happens between the floor and the table and the load on the desk plus the weight of the legs is lower than 88.1 lbs (40 kg)
- If the collision happens over too long a time, e.g., if the collision is with a soft object.

Collision Warning

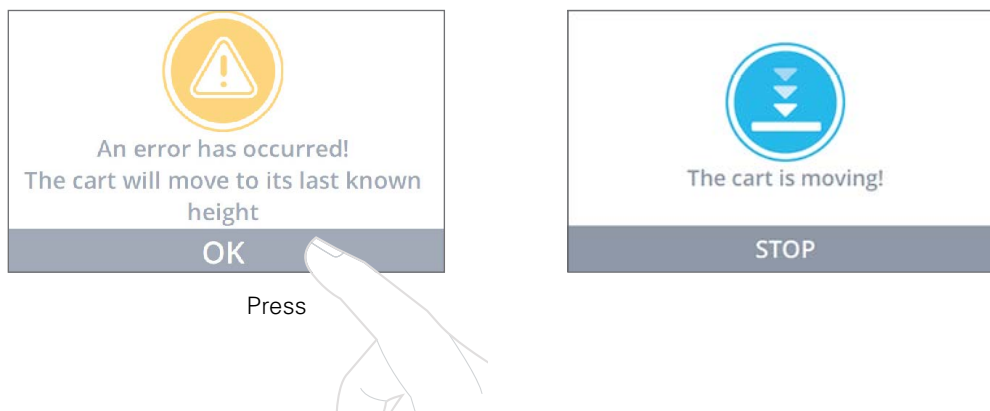

4.0 GLOSSARY OF SYMBOLS AND WARNINGS

These symbols provide alerts to safety conditions demanding attention. It is important to recognize and understand the significance of the following safety hazards when encountered on the T7 Point-of-Care Technology Cart or within the manual.



Alternating Current



IEC 60601-1, 2nd ed. Mandatory to Consult Accompanying Documents



IEC 60601-1, 3rd ed. Mandatory to Consult Accompanying Documents



Direct Current



ON/OFF Power Switch



Protective Earth (ground)



Battery Level Indicator



RJ 45 Connection



USB 2.0 Connection



Push-button on/off switch



General Warning Sign



Dangerous Voltage



Feet Entrapment

4.1 CART WARNING REVIEW



BATTERY REPLACEMENT

To maintain certification, replace the T7's battery with a Humanscale replacement battery only.



GROUNDING

Connect the T7 to an equivalent receptacle marked "Hospital Only" or "Hospital Grade" to ensure a protective earth ground.



SERVICE AND REPLACEMENT

Do not attempt to service the system while the power is on. Do not attempt to service or replace any part of the T7 unless directed to do so through Humanscale-approved documentation (i.e., this User Manual or other instructions). Only Humanscale or a Humanscale-certified entity may service or replace the cart components. If any component on the cart is missing or damaged, the cart must not be used. Contact Humanscale Customer Service immediately to request service.



DANGEROUS VOLTAGE

Do not remove the base cover—there may be electrical energized components, even when the T7 is in standby mode. Opening of the base by unauthorized personnel may cause injury and/or death. If the unit is not working properly, please contact Humanscale at 1-800-400-0625.



T7 SYSTEM WEIGHT LIMITS FOR POWERED CART

Gantry can accommodate accessories weighing up to 11.5kg (25lbs) such as but not limited to flat-panel (1 or 2) displays, scanners, bottles, etc.

Keyboard can accommodate accessories of up to 2.25kg (5lbs)

Laptop tray can accommodate accessories of up to 11.5kg (25lbs)

Storage Drawers (including optional MedLink, MedProx) weighing up to 30.4kg (67 lbs)

Worksurface can accommodate total weights of 122lbs (includes accessories on Gantry, Keyboard, Laptop Tray and any additional accessories)



DO NOT USE THE UNIT IN OR NEAR WATER OR OTHER LIQUIDS.

If the unit becomes wet, power it off immediately by unplugging the AC power cord from the wall, holding the power button under the back right corner of the work surface (if standing in front of the cart), and pulling the circuit breaker switch under the left side of the base. Wipe away any excess liquid and allow it to dry before use.



DO NOT IMMERSE THE POWER SYSTEM IN WATER.

This is an electrical hazard and can cause damage to the unit, as well as injury to the user.



USE A NONFLAMMABLE CLEANER WHEN CLEANING THE UNIT.

Failure to do so can result in death, explosion and/or fire. Always unplug the unit before cleaning.



DO NOT LEAVE THE UNIT UNATTENDED AROUND CHILDREN.

Failure to do so can result in injury and/or death.



Connecting electrical equipment to the Multi-Socket Outlet effectively leads to creating a Medical Electrical system and can result in a reduced level of safety



An extension cord or additional Multi-Socket Outlet may not be connected to the T7's integrated Multi-Socket Outlet



Only equipment to be used as part of the T7 system or compatible with power requirements may be connected to the Multi-Socket Outlet for power



Potential loss of data if battery runs out of power. Plug in AC cable to charge battery if the low-battery alarm sounds



The Non-powered T7 cart may have greater risk of leakage current with user-installed technology on-board



Installing technology in the Non-Powered T7 will pose a greater risk of hazard due to liquid spills. Extra precaution should be taken.



A hazardous risk of tipping exists when the T7 encounters either of the following heightened concern conditions:

- Navigating a step up or down of 40mm (1.5") or greater; proceed with caution or find assistance in moving the cart over a change of height of this magnitude.
 - Positioned on an inclined surface of 10° or more; avoid when applicable, but if necessary, proceed with caution or find assistance to maintain cart stability by firmly holding push handle at all times.
-



5.0 UNPACKING AND PREASSEMBLY

The T7 Point-of-Care Technology Cart should arrive upright inside a cardboard carton strapped with two plastic straps. Inside the main carton is a smaller cardboard container storing all standard and optional hardware. The entire outer packaging should be plastic shrink-wrapped. Removal of the T7 from the packaging must proceed as follows to avoid damage and the possibility of lost parts.

5.1 UNPACKING THE T7

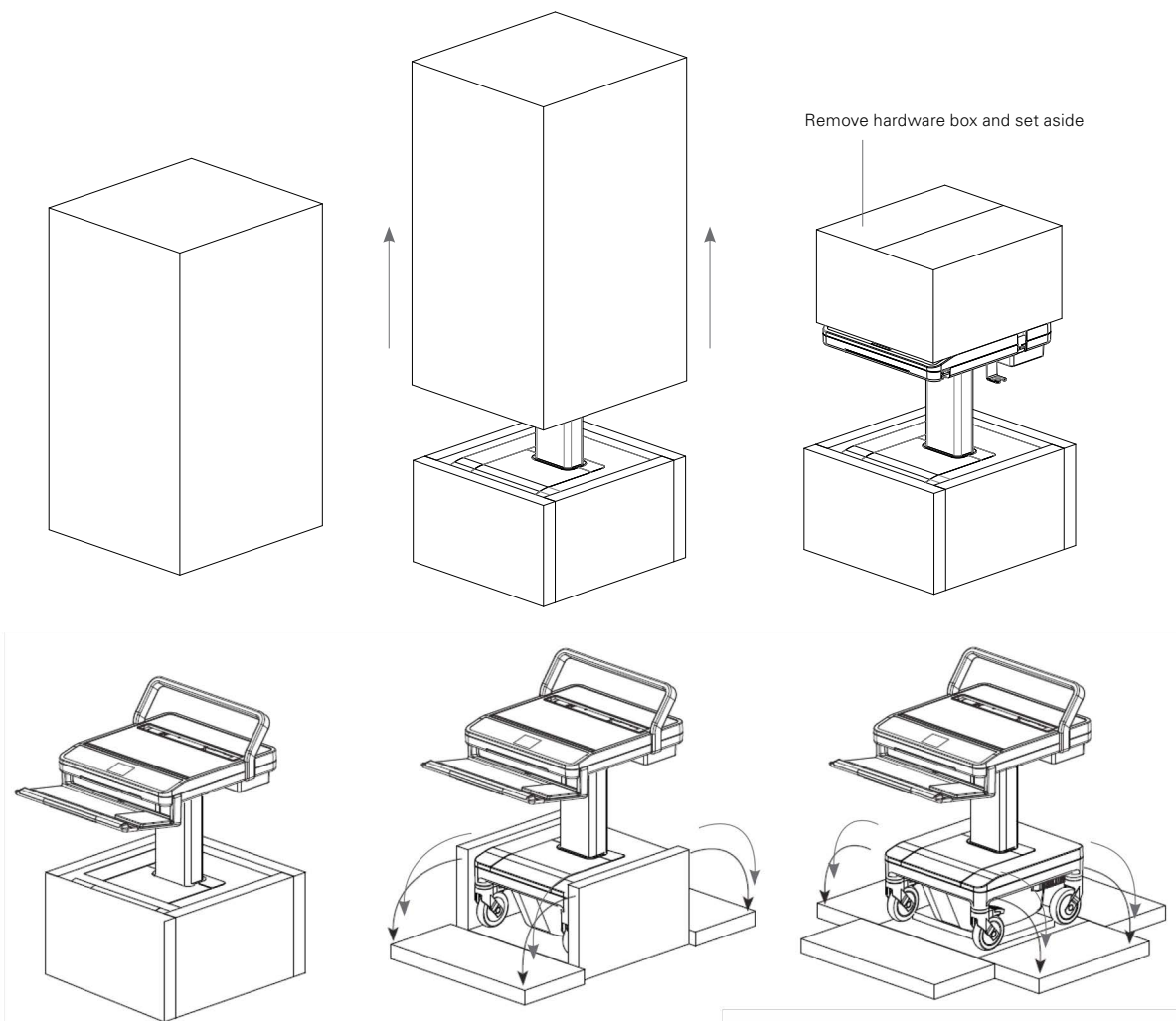

*For safety reasons, two people are required to remove the T7 from the pallet

5.2 MOUNTING A MONITOR

The T7 has two types of monitor mounts, fixed and height-adjustable. Both utilize a similar quick-release lock and VESA-style mounting plate.

Fixed-Height Monitor Assembly

1. Mount the VESA plate to your monitor using either the four 75 mm- or 100 mm-spaced holes as needed.
2. Lower the monitor arm by inserting the tongue on the back of the VESA plate into the quick-release mount on the cart; be sure that you hear a “click.”

Adjustable-Height (UFEA) Monitor Assembly

1. To detach the VESA plate from the UFEA body, first loosen the four screws inside the UFEA track and slide the UFEA body to the left, allowing you to pull the body away from the VESA plate.
2. Mount the VESA plate to your monitor using either the four 75 mm- or 100 mm-spaced holes as needed.
3. Determine the appropriate positioning for the UFEA on your monitor and slide the UFEA body back on the VESA plate at the corresponding position; be sure that you hear a “click.”
4. Slide the body to the right, setting the screws in the smaller holes and tightening them down.
5. Lower the monitor and UFEA onto the monitor arm by inserting the tongue on the back of the UFEA into the quick-release mount on the cart.

After the monitor is mounted, the power and data cables can be routed inside the gantry by removing the rubber cover on the back.



Adding a monitor may cause instability risks. The unit should be handled with caution with a monitor attached.

5.3 INSTALLING A COMPUTER

Prior to reattaching the work surface covers, you must install a computer, using the T7's computer-strap assembly to stabilize the computer during use.

Installing a Computer (Thin Client, Laptop or Small Form Factor PC)

1. To install a computer, first remove the back panel of the work surface and then the front work surface cover by removing the four screws from the underside of the work surface frame.
2. Plug the computer's power adapter to one of the outlets inside the technology well.
3. Slide the brackets of the computer hold-down assembly into the slots on the frame beneath the work surface and set their width to be slightly greater than the computer's.
4. If using a laptop, set the laptop on the frame of the work surface. Install domed bumpers under rear of laptop to raise the screen to desired height through slot in work surface and, with the screen open, move it toward the cutaway in the rear cover.
5. For all other computer types, place the computer between the brackets on the frame of the work surface.
6. Thread the hold-down strap through the loop-end and tighten it across the computer, being sure that it is tight across the top and that the brackets are close to the computer body.
7. Power on the computer, and place the front work surface cover over the computer. Then, replace the back panel of the work surface and lock it. Secure the cover with the four screws removed earlier.



Maximum total power rating for electronic equipment connected to the T7 is 150 W



Additional safety risks may arise if devices not compliant with the following standards are connected to the T7:

- IEC/UL/CSA 60065
 - IEC/UL/CSA 60950-1
 - IEC/UL/CSA 62368-1
 - ICES-003
-

After the computer and monitor have been installed, reattach the front work surface cover, using the four screws removed earlier. Slide the rear cover on, being sure that it fits securely with the front cover, and lock it using the keys provided.

OPERATION



6.0 POWER SYSTEM OVERVIEW

Please read the following details regarding the T7 Point-of-Care Technology Cart's power system before operation.

6.1 INITIAL SYSTEM STARTUP AND SHUTDOWN

Before the T7 cart can be used for the first time, the battery module must be fully charged. When shipped from the factory, the battery module is disconnected from the electronics portion of the system for storage. To reconnect the system, follow these steps:

- Remove the battery cover at the base of the cart.
- Locate two 20A fuses (these are inside a plastic bag taped to the side of the lithium battery) and re-connect them into the fuse holders.
- Take the lithium battery cable and connect it to the lithium battery (there are two RJ45 connector ports on the battery, either one maybe used).
- Re-install the battery cover.
- Locate the cart's power cord and plug it into a powered hospital-grade wall receptacle. Locate the on/off switch where the power cord enters under the work surface. Push the (minus) - sign. Upon doing so, the LEDs that are located to the right of the display will light up. Depending on the length of the time the cart was in transit or in storage, you may get a different configuration of lights (see Section 6.3 Battery Level Indicator).
- To turn the T7 cart on, locate the main power button located under the rear left side of the work surface when facing the front of the cart. Push and hold the push button in for a few seconds until you hear a click and a beep. At this time, the display will illuminate and go through a boot-up process and to the main screen. The process described above can be found in more detail inside the quick start guide included with every T7 Cart.
- Every time the T7 is turned on, the calibration procedure must be performed first before using the cart:
 - Select the "settings icon" located on the top right hand corner of the display next to the battery charge indicator.
 - Scroll down and select "Calibrate height adjust", select "ok".
 - The column will automatically move up and down during calibration.
 - After calibration is complete, the T7 cart will be ready for use. To power system down, push and hold the main power push button in for a few seconds until you hear a beep and the display turns off.



When operating the T7 with the AC plug connected to a socket, do not position the unit so it is difficult to disconnect from the wall or reach the AC switch in the event of an emergency

6.2 PROPER POWER SYSTEM RECHARGING

To prolong the T7's power system and condition the battery for optimal performance, always charge the battery fully. To recharge the T7, simply plug the power cord into a hospital-grade receptacle. The cart has started its charging cycle once the BLI lights strobe from bottom to top (note: initially all of the LEDs may be dark or only the red LED illuminated). For maximum battery utilization and long life, the cart power system features a sophisticated charging system with four modes of charge: Trickle, Bulk, Overcharge, and Float Charge. When first plugged in, the cart enters a Trickle Mode, during which a small amount of current is fed to the battery system to determine its voltage level and state of charge. When a predetermined level is reached, the charger automatically transitions to Bulk Mode, during which the recharge current is delivered to the battery at maximum level to facilitate faster restoration of operation. As the battery reaches full capacity, the charger moves into Overcharge Mode to ensure that maximum charge is returned to the battery. The charger then enters a Float Charge Mode for long-term maintenance of the charge level until power is drawn from the system.

Tips to Optimize Your Battery Life

- Do not let the battery drain to a fully discharged state (which you will be alerted to by a sound and a red indicator on the dashboard next to the screen). If the battery reaches a discharged state, this will potentially damage the life of the battery. If possible, plug the T7 in frequently to keep the charge as strong as possible and prevent a fully discharged state.
- Always fully charge the battery. Do not stop charging until the battery has reached a full charge.
- Do not store the battery in a discharged state. If possible, keep the T7 plugged in when not in use.

6.3 BATTERY LEVEL INDICATOR

The Battery Level Indicator (BLI) indicates the status of the T7's power system. Several modes are displayed through the BLI.

- **Turned off or fully discharged battery:** All of the T7's BLI lights are dark.
- **Charging Mode:** The BLI is depicted with four bars representing increments of battery charge level. If the battery is less than 25% charged, the lowest bar will be blinking. If the battery is less than 50% charged, the lowest bar will be solid and the second bar will be blinking. If the battery is less than 75% charged, the lowest two bars will be solid and the second to highest bar will be blinking. If the battery is less than 100% charged, the lower three bars will be solid and the top bar will be blinking.
- **Charging Finished Mode:** When input power is removed from the cart by unplugging from the wall, all four lights are illuminated.
- **Discharge Mode:** The BLI displays how much battery capacity is left. At full battery capacity, all lights are illuminated. As power is drawn from the battery, the lights extinguish sequentially from top to bottom, counting down capacity in approximately 25% increments. Once the cart reaches the 25% level, the bottom LED turns to yellow. Once the battery level reaches the critically low battery level, the bottom LED turns red and an optional beeping sounds. This is an indication that approximately one minute of run time remains and the system should be plugged in immediately to prevent loss of operation and/or data.

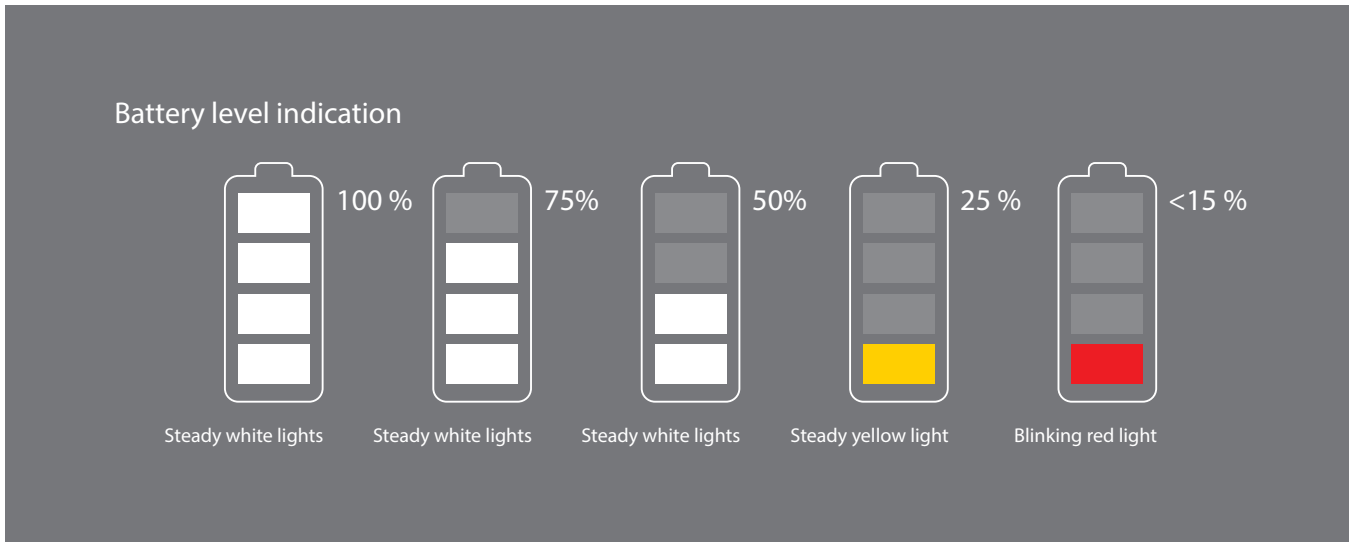

6.4 SHUTDOWN SWITCH

The T7's shutdown switch is located underneath the work surface, in the rear left-hand corner as you are facing the cart. Its main function is to limit power to the customer accessory outlets. It also turns the touch screen display off. This function is useful when initially configuring the added cart equipment (hardware, monitor, etc.) or to reduce discharge of internal battery source when the cart will not be used for an extended period of time.

7.0 ADJUSTING THE T7

Proper ergonomics can help reduce and prevent workplace injuries by lessening the physical demands on the worker. Ergonomically designed products, such as the T7 point-of-care technology cart, take into account the wide range of people who will use the product, so that everyone, regardless of their stature, can use the product easily and comfortably—essentially, allowing the job to fit the worker instead of the other way around.

The T7's 20" (50.8 cm) height range ensures comfortable accommodation for both seated and standing workers.

7.1 TIPS ON USING THE T7

- Push the cart with arms placed close to body. Do not pull the cart. Pushing utilizes your own body weight, while pulling causes undue stress and can result in ankle and knee injury.
- Keep the cart well maintained and the cart equipment organized. A well-maintained cart will be easier to move and an organized cart will be less susceptible to accidents.

7.2 ERGONOMIC MONITOR POSITIONING

Position the monitor so that the top of the screen is slightly below eye level.

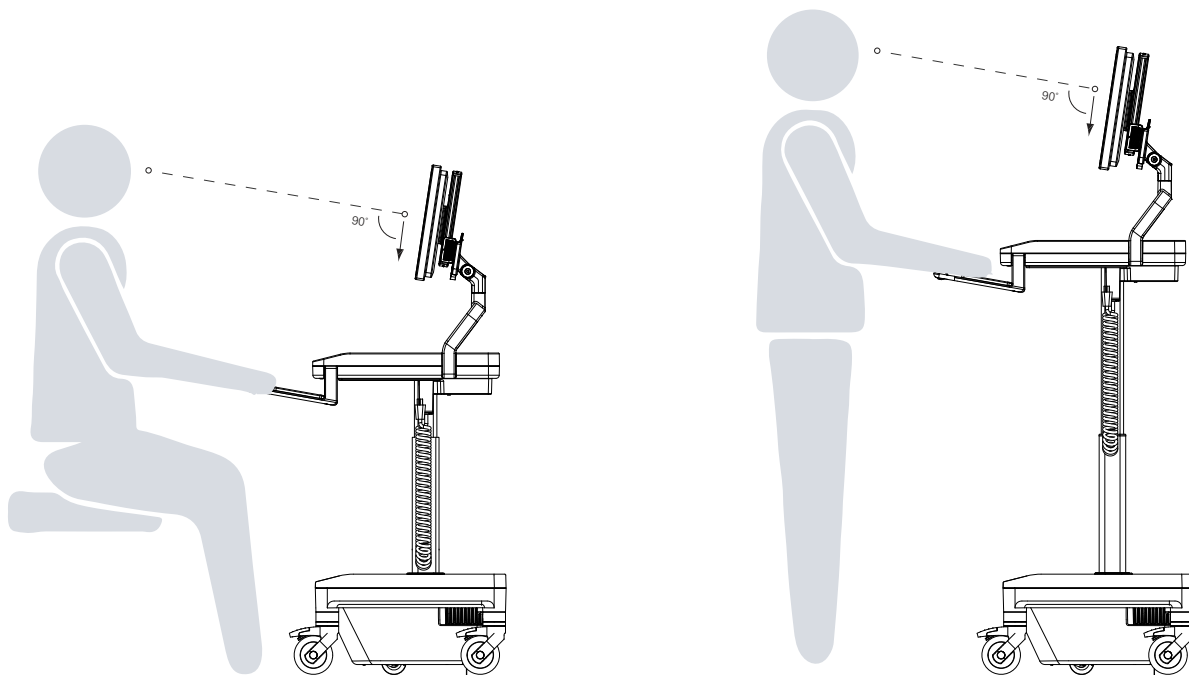

8.0 TROUBLESHOOTING AND FREQUENTLY ASKED QUESTIONS

Why am I not getting power to the computer or monitor?

First, be certain that all power cords are properly connected to the outlet mounts and that all equipment power switches are turned on, meaning the computer, monitor, and any other accessories that will be plugged into the internal AC Power Source Triple Tap. Also, the correct switches on the T7 must be engaged to get power to the Internal AC Power Source Triple Tap. Be sure that the Battery Level Indicator (BLI) is not showing a red or blinking red light. If so, the T7 needs to be charged.

How do I know if the T7 requires charging?

Check the Battery Level Indicator (BLI) on the front of the T7. If the red light is illuminated or blinking red, the cart needs to be charged. The T7 may be charged at any time, but immediate charging is recommended if the BLI is showing orange or red. (See Section 6.3 Battery Level Indicator, page 39.)

When should I charge the system?

When the T7 first arrives, charge it to full capacity. (See Section 6.1 Initial System Startup and Shutdown, page 38.) After the proper initial charge, you may recharge at any time, but charging is recommended when the BLI is showing red.

Can I access the power supply to repair it?

No. Do not attempt to access or repair the power supply. Tampering with the power supply could damage the T7, void the warranty, and/or cause personal injury. You must contact Humanscale so that a trained technician can service the cart.

Can I use an extension cord with the T7?

For safety reasons, using an extension cord with the T7 is not recommended. This applies to all outlets and power cords connecting to and from the cart. The T7 comes with a coiled AC cord that should provide necessary extension.

What should I do if the power goes out while I'm recharging the T7?

Unplug the T7 from the AC outlet. When power is restored, continue recharging.













If the T7 gets wet, what should I do?

Unplug it and power it off immediately, wipe off any excess liquid, and allow the T7 to dry before using it again.

What happens when the battery runs out while the cart is adjusting?

When power is restored, access the IT (see page 23) screen and calibrate the cart. To calibrate, push the calibrate button and release. The calibrate button will flash yellow and the T7 cart will start to move upward. Once T7 cart reaches a height of 6' 03" (190 cm) standing, the calibration is finished.













9.0 ACCESSORIES

		
<p>T7-SP-CNTR</p> <p>Sharps Container</p>	<p>T7-U-BSKT</p> <p>Utility Basket Inner Dimensions (D x W x H): 10.30" x 11.80" x 3.80" 264 mm x 302 mm x 98 mm</p>	<p>T7-P-SHLF</p> <p>Printer Shelf Inner Dimensions (D x W x H): 11.7" x 7.6" x 13.2" 297.18 mm x 193.04 mm x 335.28 mm</p>
		
<p>T7-SC-BKT</p> <p>Universal Scanner Bracket Inner Dimensions (W x H): 3.2" x 2.5" 81.28 mm x 63.5 mm</p>	<p>T7-G-B-HLD</p> <p>Glove Box Holder Inner Dimensions (D x W x H): 4.2" x 5.2" x 9.8" 106.68 mm x 132.08 mm x 248.92 mm</p>	<p>T7-S-UT-DR</p> <p>Standard Utility Drawer Maximum Opening (D x W x H): 7.7" x 6.7" x 3.7" 195.58 mm x 170.18 mm x 93.98 mm Tapers to (D x W x H): 6.8" x 5.9" x 3.7" 172.72 mm x 149.86 mm x 93.98 mm</p>
		
<p>T7-L-UT-DR</p> <p>Locking Utility Drawer Maximum Opening (D x W x H): 7.7" x 6.7" x 3.7" 195.58 mm x 170.18 mm x 93.98 mm Tapers to (D x W x H): 6.8" x 5.9" x 3.7" 172.72 mm x 149.86 mm x 93.98 mm</p>	<p>T7-CPU-HLD</p> <p>T7 CPU Holder Fits CPU's up to (D x W x H): 16.5" x 3.4" x 11.8" 419.1 mm x 86.36 mm x 299.72 mm</p>	<p>T7-RAR</p> <p>Rear Accessory Rail Inner Dimensions (D x W x H): 4.92" x 17.48" x 0.126" 125 mm x 444 mm x 3.2 mm</p>
		
<p>T7-CB</p> <p>T7 Cross Bar for 2 monitors</p>	<p>TPV-19 TPV-27</p> <p>VESA Accessory Rail Mount with 19" or 27" (482.6 mm or 685.8 mm) Rail Compatible with ViewPoint Rail Accessories on pg 39. Fits up to 2 and 4 accessories respectively.</p>	<p>T7-AR-SC-MNT</p> <p>T7 Accessory Rail Scanner Mount - Accessory Rail Required.</p>

9.0 ACCESSORIES (CONT.)

		
T7-C-SC-BK	HCVESA1X2	HCVESA2X2
T7 Code Scanner Bracket	3.9" x 7.9" (100 mm x 200 mm) VESA Plate	200 mm x 200 mm
		
HCVESA2X4	HCVESADD	T7-CAM-MNT
7.9" x 15.8" (200 mm x 400 mm)	Drop Down VESA Plate	T7 Camera Mount

9.0 ACCESSORIES (CONT.)

		
<p>T7-ST-DRW-3</p> <p>Front mounted single drawer with no lock Dimensions (D x W x H): 264 mm X 302 mm X 98 mm 10.30" X 11.80" X 3.80"</p>	<p>T7-ST-DRW-2</p> <p>Front mounted three drawers with no lock Dimensions (D x W x H): 264 mm X 302 mm X 98 mm 10.30" X 11.80" X 3.80"</p>	<p>T7-ST-DRW-11</p> <p>Front mounted single drawer with key lock Dimensions (D x W x H): 264 mm X 302 mm X 98 mm 10.30" X 11.80" X 3.80"</p>
		
<p>T7-ST-DRW-4</p> <p>Front mounted single drawer with electronic keypad lock Dimensions (D x W x H): 242 mm X 302 mm X 98 mm 9.50" X 11.80" X 3.80"</p>	<p>T7-ST-DRW-9</p> <p>Front mounted single drawer with electronic keypad lock Dimensions (D x W x H): 280 mm X 200 mm X 75 mm 11.00" X 7.80" X 2.90"</p>	<p>T7-ST-DRW-1</p> <p>Front mounted single drawer with electronic keypad lock Dimensions (D x W x H): 264 mm X 302 mm X 218 mm 10.30" X 11.80" X 8.50"</p>
		
<p>T7-ST-DRW-5</p> <p>Front mounted two drawers with electronic keypad lock Dimensions (D x W x H): 242 mm X 302 mm X 98 mm 9.50" X 11.80" X 3.80"</p>	<p>T7-ST-DRW-8</p> <p>Front mounted two drawers with electronic keypad lock Dimensions (D x W x H): 280 mm X 200 mm X 75 mm 11.00" X 7.80" X 2.90"</p>	<p>T7-ST-DRW-6</p> <p>Front mounted two drawers with electronic keypad lock Dimensions (D x W x H): 339 mm X 297 mm X 148 mm 13.30" X 11.60" X 5.80"</p>
		
<p>T7-ST-DRW-10</p> <p>Front mounted five drawers with electronic keypad lock Dimensions (D x W x H): (4X) 258 mm X 125 mm X 48 mm 10.10" X 4.90" X 1.80" (1X) 258 mm X 300 mm X 98 mm 10.10" X 11.80" X 3.80"</p>	<p>T7-ST-DRW-7</p> <p>Front mounted five drawers with electronic keypad lock Dimensions (D x W x H): (4X) 264 mm X 300 mm X 48 mm 10.30" X 11.80" X 1.80" (1X) 264 mm X 300 mm X 98 mm 10.30" X 11.80" X 3.80"</p>	<p>T7-ST-DRW-12</p> <p>Rear mounted single drawer with electronic keypad lock Dimensions (D x W x H): 300 mm X 85 mm X 225 mm 11.81" X 3.35" X 8.86"</p>



10.0 MAINTENANCE AND CLEANING

To ensure optimal performance of the T7 Point-of-Care Technology Cart, please observe the following maintenance and cleaning schedule monthly.

10.1 CART MAINTENANCE



SERVICE AND REPLACEMENT

Do not attempt to service or replace any part of the T7 unless directed to do so through Humanscale-approved documentation (i.e., this User Manual or other instructions). Only Humanscale or a Humanscale-certified entity may service or replace the cart components. If any component on the cart is missing or damaged, the cart must not be used. Contact Humanscale Customer Service immediately to request service.



CABLES

All cables aside from the AC power cord, keyboard USB, mouse USB, and PC/laptop power cords are routed internally within the T7. Be sure that cords are clean and not broken or cut at any location. Be sure that they are solidly connected to their respective outlet.



CASTERS

Check casters periodically to ensure that they are clean and free of any debris that could prevent smooth operation. Avoid moving the T7 across uneven, dirty, or damaged surfaces.



CUSTOMER EQUIPMENT

Be sure equipment is balanced and mounted securely to the T7. Repositioning the cart components too high or too low may create an unstable condition, leading to equipment damage or personal injury. Note: Failure to adhere to these guidelines may void Product Warranty. (See Section 18.0 Warranty, page 64.)



BATTERY MAINTENANCE

All battery maintenance must be performed by a trained technician. Before performing all battery maintenance, put the T7 in Standby Mode (see Section 6.3 Battery Level Indicator, page 40.), unplug the power cord from the wall, and disconnect the ground (black) lead from the battery. Visually inspect the cart's battery monthly. If a battery bulges severely on charge, it is an indication of a blocked valve or an overcharge situation. Please contact Humanscale if you notice any battery defects.

Cable connections must be cleaned and tightened as part of your scheduled maintenance. Many battery problems are caused by dirty or loose terminal connections. First, remove the battery from the T7 prior to cleaning. The battery terminals should be cleaned using three tablespoons of baking soda in a pint of water.

The battery supplied with the T7 is sealed. Never attempt to open the battery or add any water or other fluids.

Disconnect & remove battery from cart when there is any scheduled service, and all situations which places the T7 cart in an inactive state for more than 14 days.

10.2 CART CLEANING

The following procedures are not guaranteed to control infection. Consult the hospital infection-control administrator or epidemiologist regarding specific cleaning procedures and processes.



Always unplug the T7 and power it down before cleaning.

All exterior surfaces, excluding electrical components, will withstand cleaning by most commonly used, diluted, non-abrasive solutions such as quaternary ammonium compounds, ammonia, enzyme cleaners, bleach and alcohol solutions.

Pen and permanent and dry-erase marker can be removed with 91% isopropyl alcohol and a soft cloth.

Iodine stains can be removed with commonly used cleaners and a soft cloth.

Never clean the T7 with steel wool or other abrasive materials that will damage the surface finish.



Do not rub a wet or damp cloth over any electrical components. Do not immerse the T7 or its components in liquid or allow liquids to flow into internal compartments or over any electrical components. Thoroughly dry all surfaces after cleaning.



Do not use flammable cleaners on T7 surfaces due to close proximity of electrical power and equipment.

It is recommended that any cleaning solution be tested on a small, inconspicuous area to ensure surface is not harmed.

11.0 DIMENSIONS AND RANGE OF ADJUSTMENTS

T7 POWERED CART | PC, Fixed Monitor Arm, Fixed Keyboard Tray

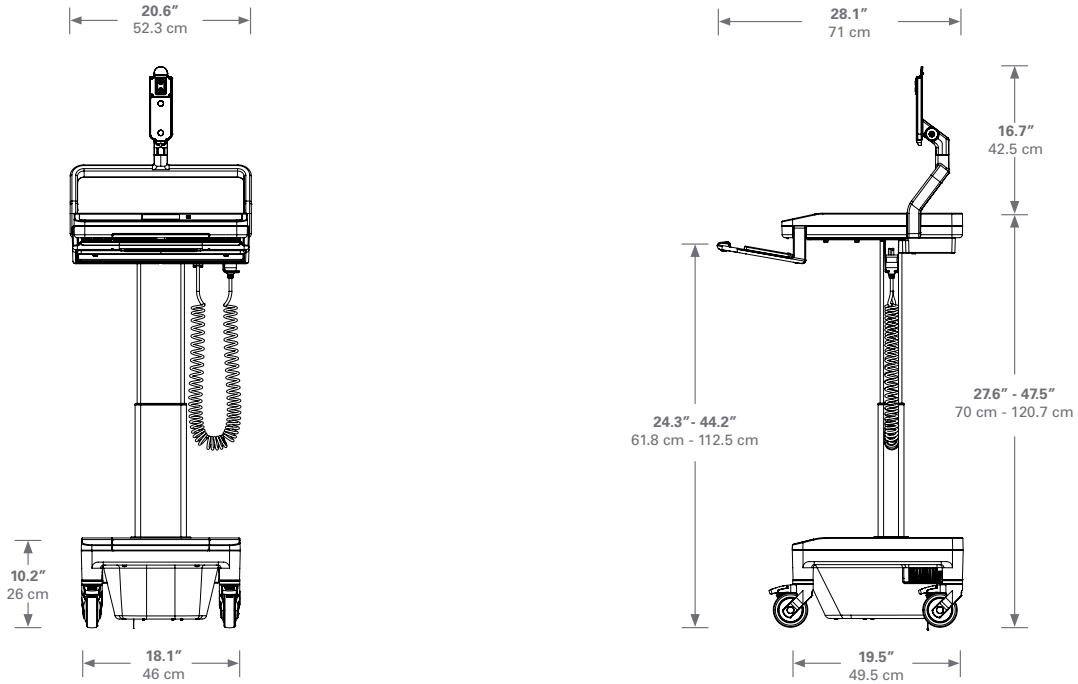

T7 POWERED CART | PC, Fixed Monitor Arm, Articulating Keyboard Tray

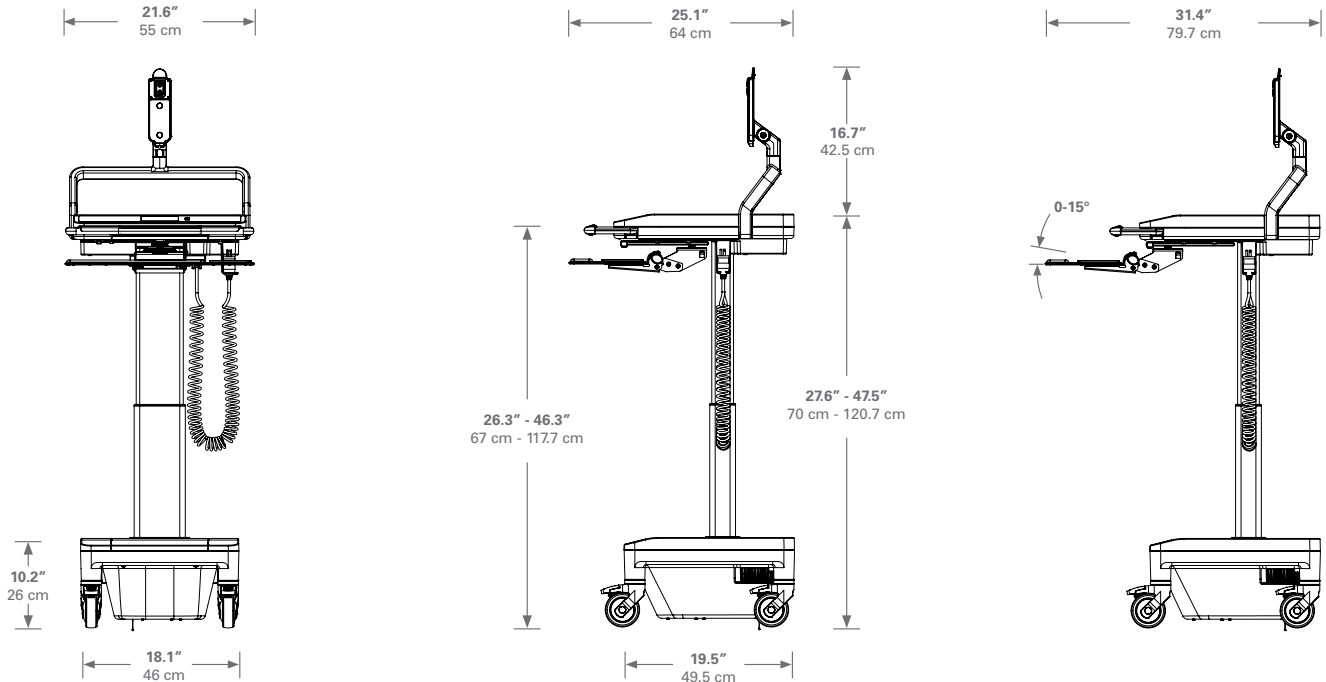

T7 POWERED CART | PC, UFEA, Fixed Keyboard Tray

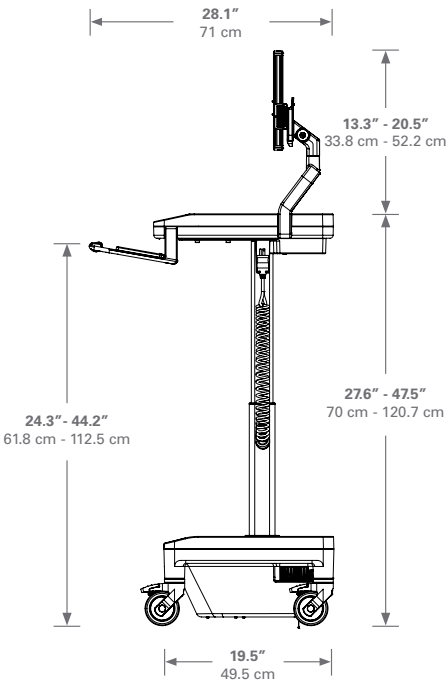
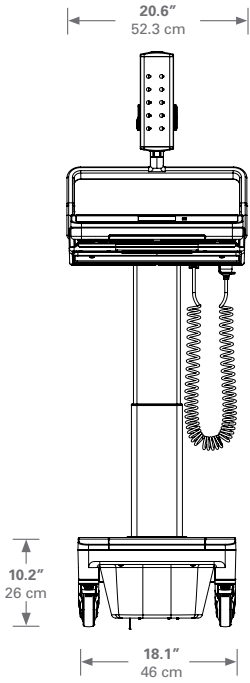

T7 POWERED CART | PC, UFEA, Articulating Keyboard Tray

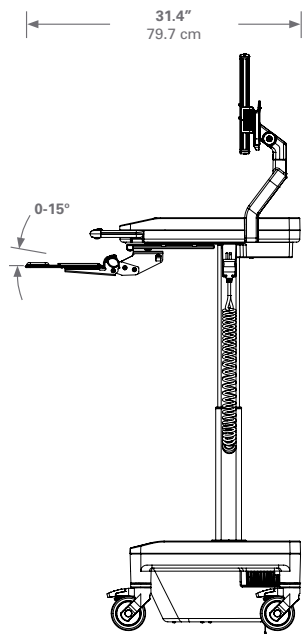
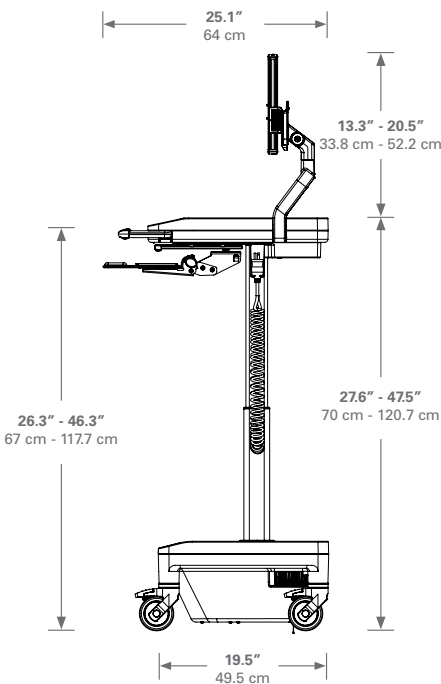
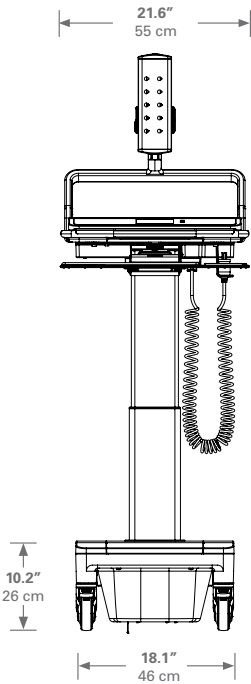

T7 POWERED CART | Laptop, Fixed Keyboard Tray

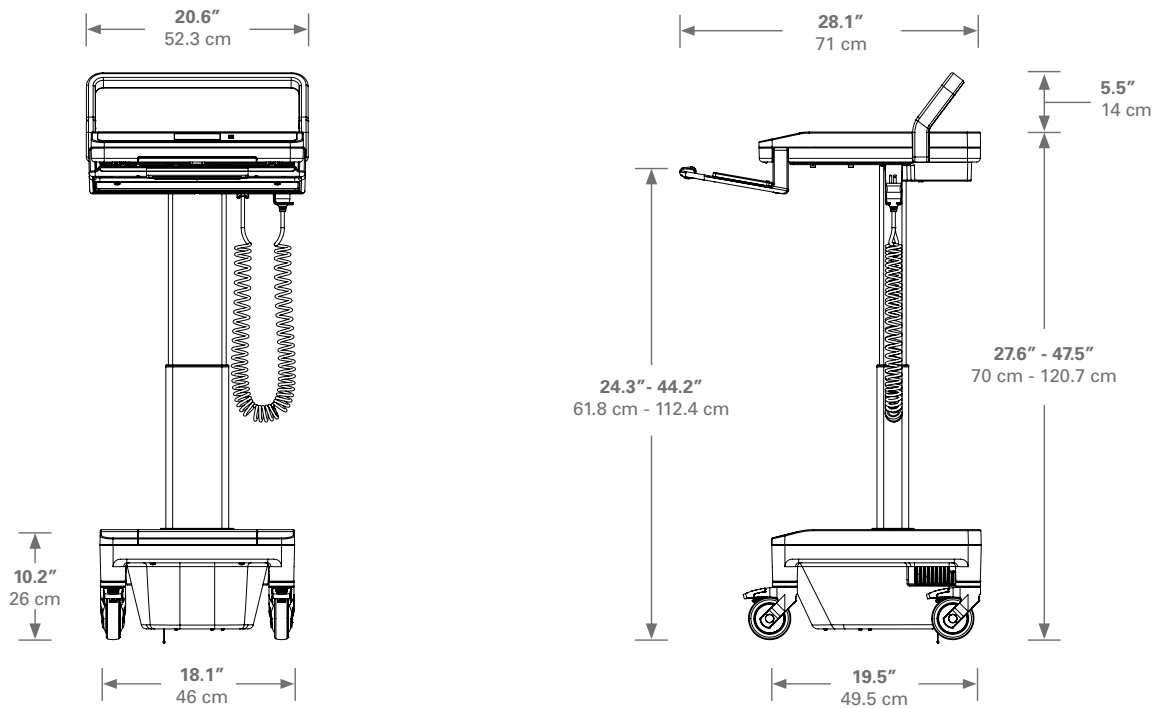

T7 POWERED CART | Laptop, Articulating Keyboard Tray

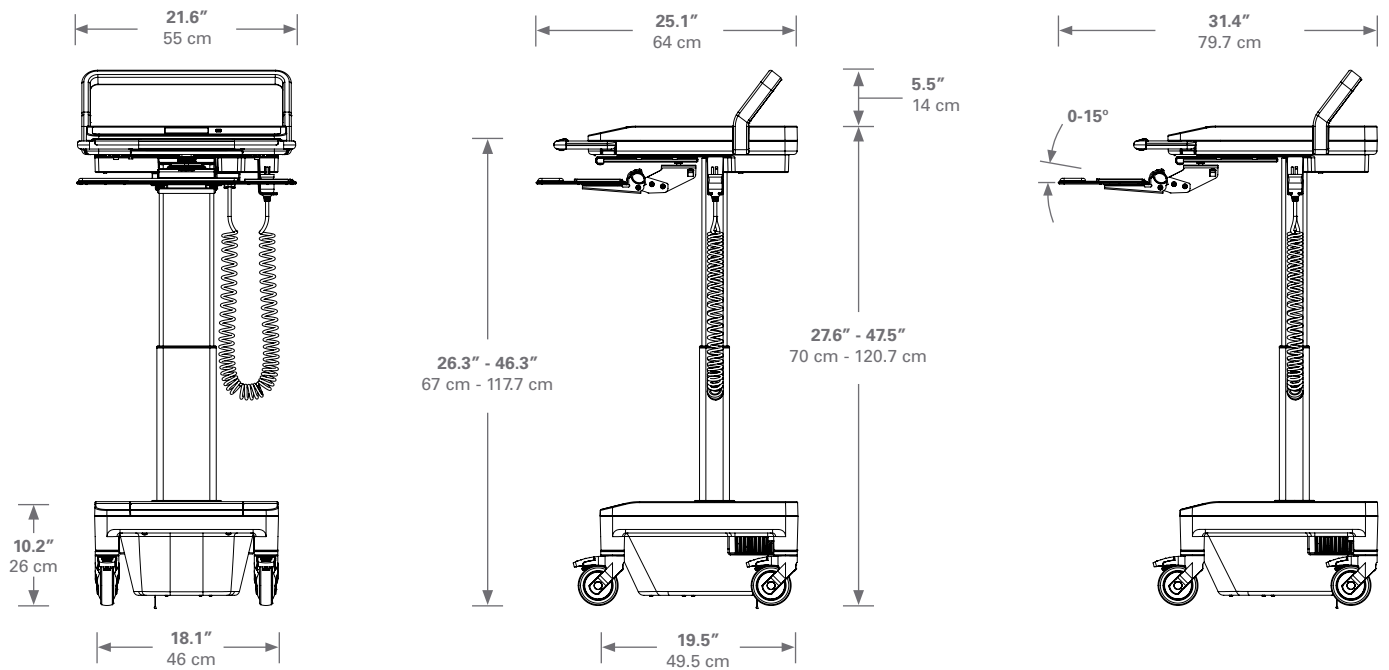

T7 NON-POWERED CART | PC, Fixed Monitor Arm, Fixed Keyboard Tray

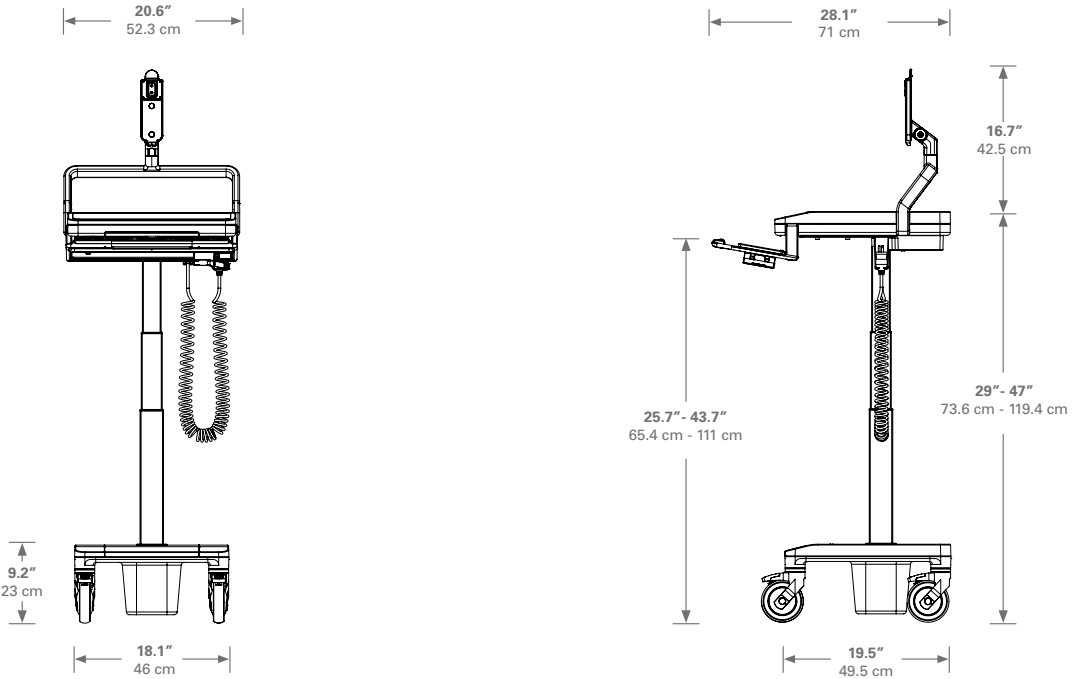

T7 NON-POWERED CART | PC, Fixed Monitor Arm, Articulating Keyboard Tray

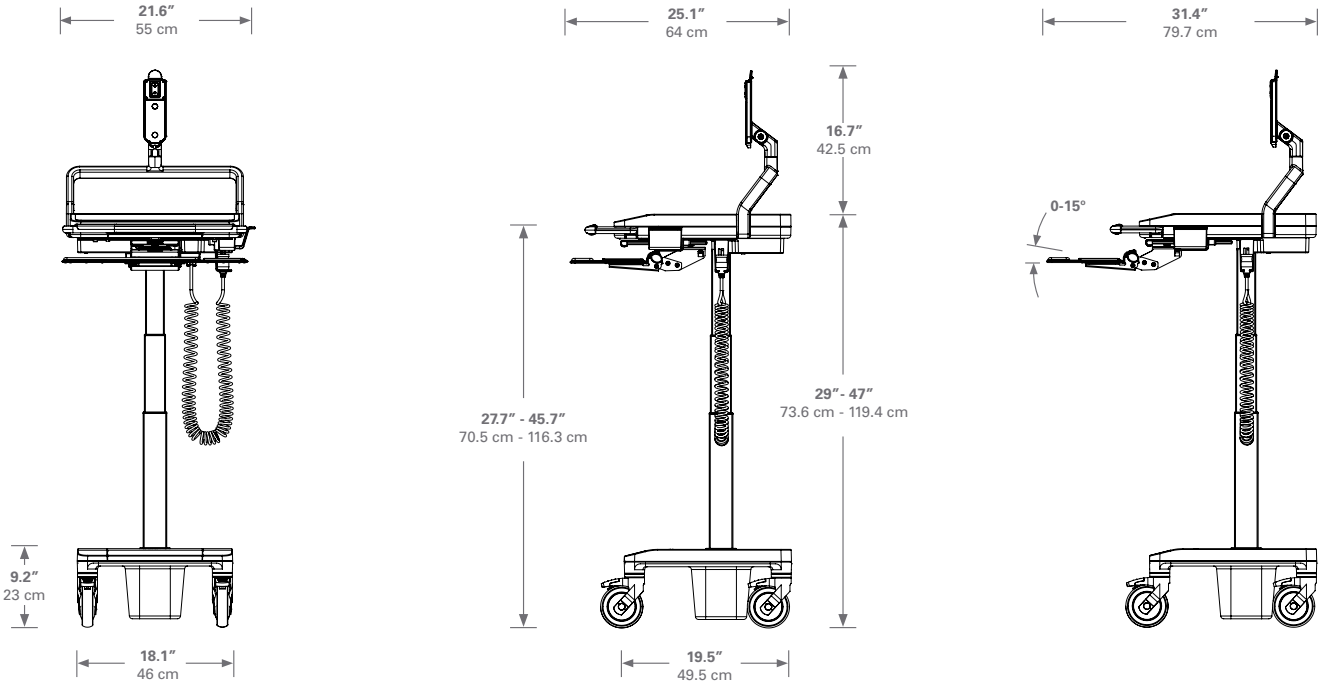

T7 NON-POWERED CART | PC, UFEA, Fixed Keyboard Tray

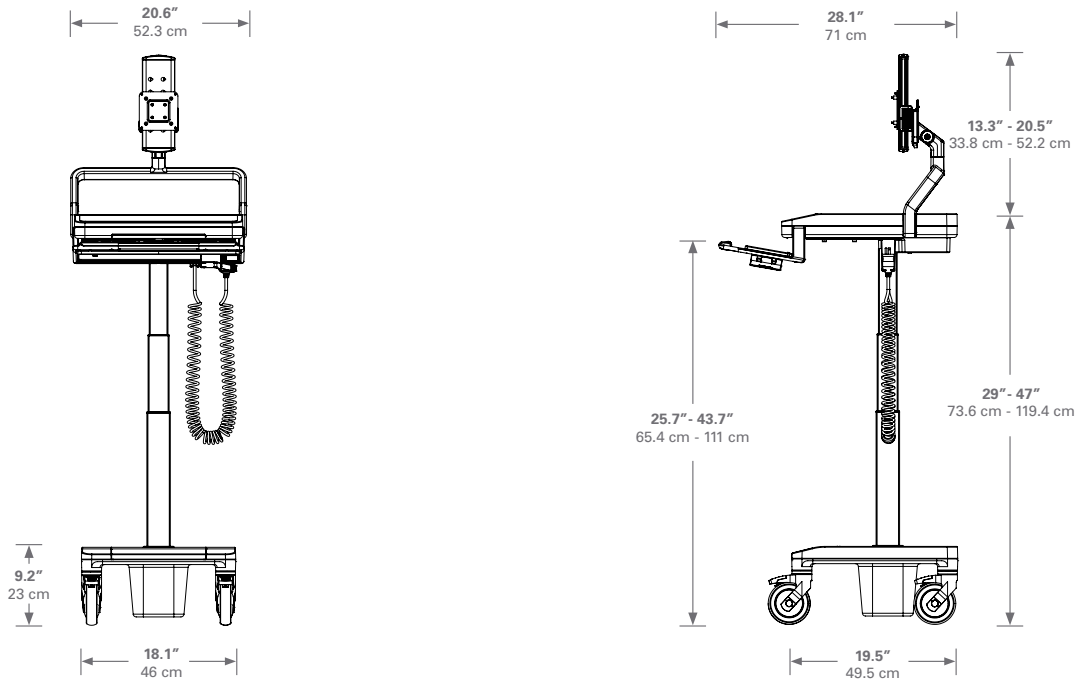

T7 NON-POWERED CART | PC, UFEA, Articulating Keyboard Tray

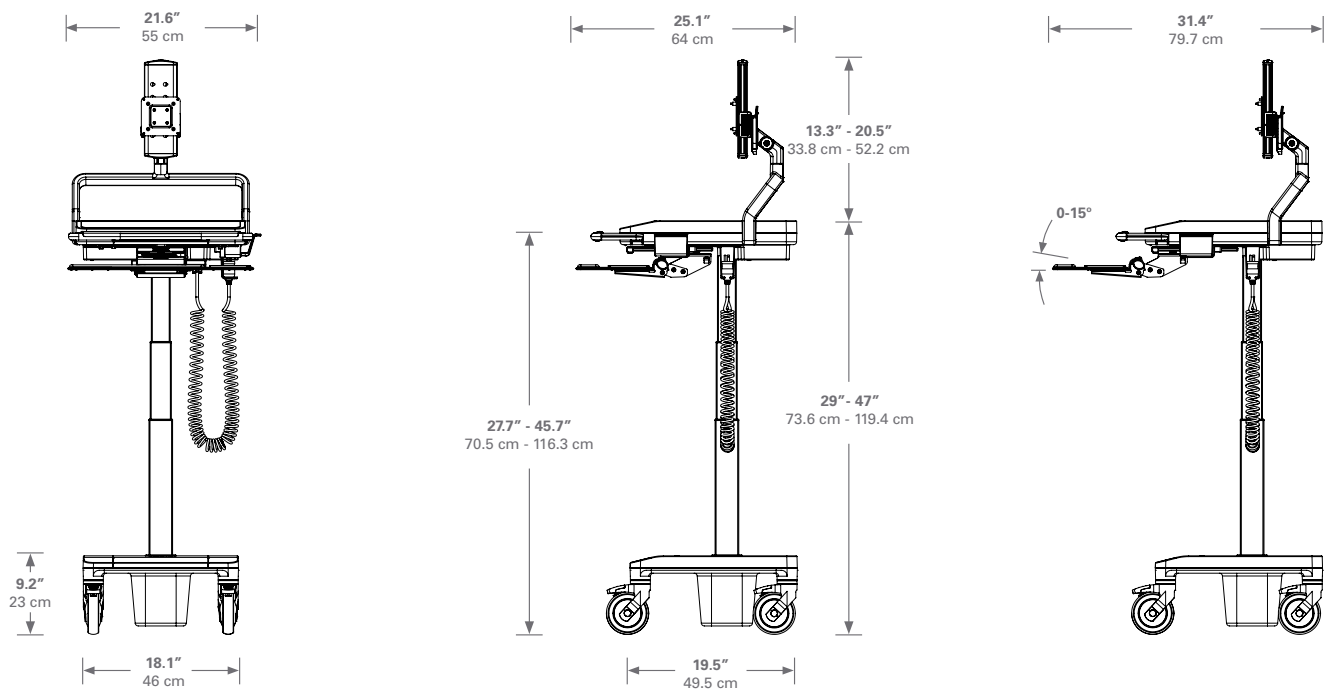

T7 NON-POWERED CART | Laptop, Fixed Keyboard Tray

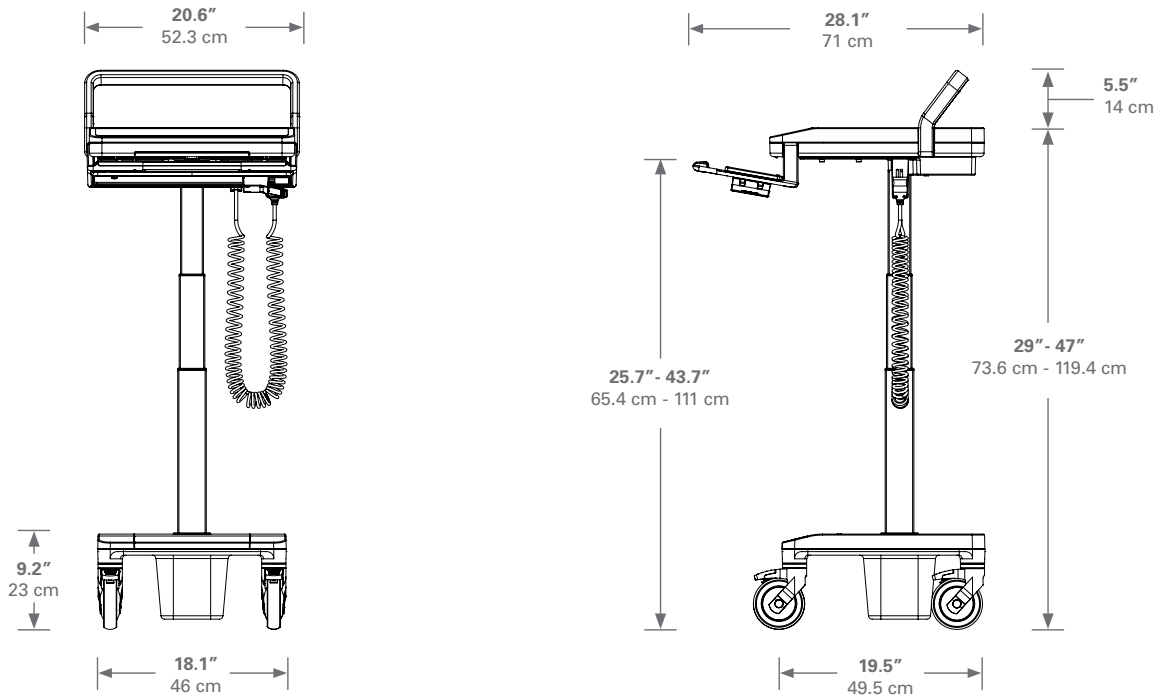

T7 NON-POWERED CART | Laptop, Articulating Keyboard Tray

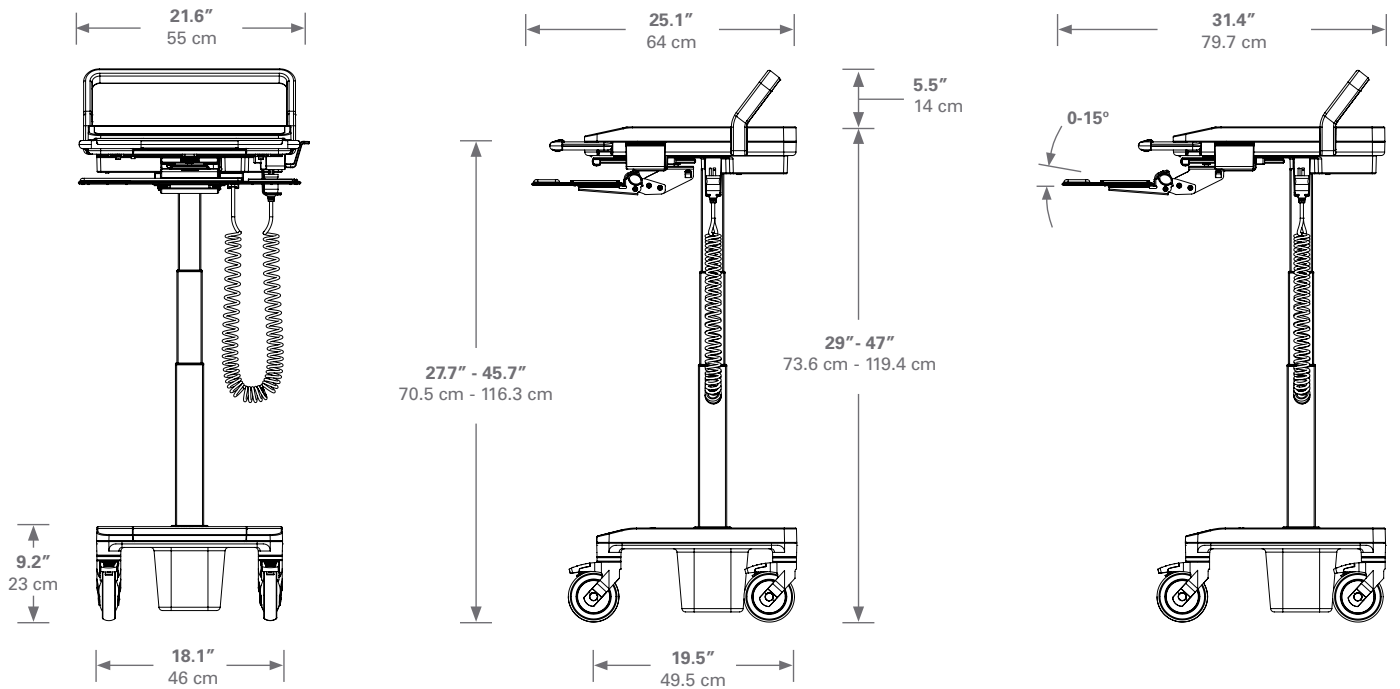

11.1 MONITOR ADJUSTMENT RANGE

Rotation Range

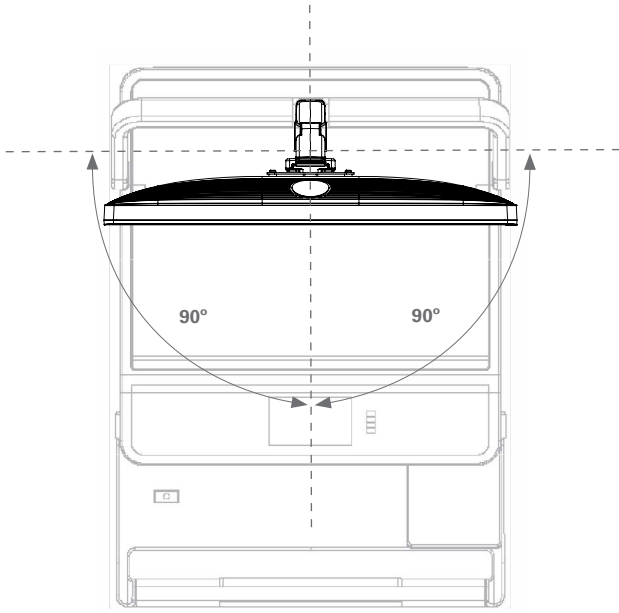

Tilt Range

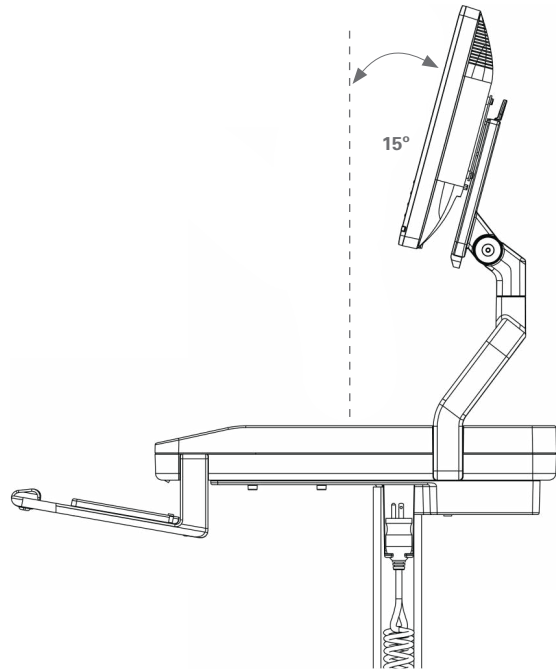

12.0 RADIATED EMISSIONS



The use of accessories and cables, other than those specified or sold by the manufacturer of the equipment as replacement parts for internal components, may result in increased emissions or decreased immunity of the equipment.

The T7 Point-of-Care Technology Cart may cause interference when used adjacent to or stacked with electrical equipment outside the system and could affect normal operation of said equipment. Do not stack additional electrical equipment on top of the work surface enclosure.

The T7 Point-of-Care Technology Cart is intended for use by healthcare professionals only. It may cause radio interference or may disrupt the operation of nearby equipment. It may be necessary to take mitigation measures, such as re-orienting or relocating the T7 Cart or shielding the location.

12.1 RECOMMENDED SEPARATED DISTANCES

The T7 is intended for use in the electromagnetic environment specified below in which radiated disturbances are controlled. The T7 user can help prevent electromagnetic interference by maintaining a minimum distance between portable and mobile RF Communications Equipment and the T7 as recommended below, according to the maximum output power of the communications equipment.

WARNING: Portable RF communications equipment (including peripherals such as antenna cables and external antennas) should be used no closer than 30cm (12 inches) to any part of the T7, including cables specified by Humanscale. Otherwise, degradation of the performance of this equipment could result.

For transmitters rated at a maximum output power not listed above, the recommended separation distance (D) in meters (M) can be determined using the equation applicable to the frequency of the transmitter, where (P) is the maximum output power rating of the transmitter in watts (W) according to the transmitter manufacturer.

Max Output Power (W)	Separation (M)	Separation (M)	Separation (M)
	150 kHz to 80 MHz D = 1.2 (SartP)	81 to 800 MHz D = 1.2 (Sart P)	801 MHz to 2.5 GHz D = 1.2 (Sart P)
0.01	0.12	0.12	0.23
0.1	0.38	0.38	0.73
1	1.2	1.2	2.3
10	3.8	3.8	7.3
100	12	12	23

Equipment and Systems that are NOT Life-Supporting

Note 1: At 80 MHz, the higher frequency range applies.

Note 2: These guidelines may not apply in all situations. Electromagnetic propagation is affected by absorption and reflection from structures, objects and people.

12.2 GUIDANCE AND MANUFACTURER’S DECLARATION—EMISSIONS

The T7 is intended for use in Professional Healthcare Facility environment specified below. The customer or user of the T7 Cart should ensure that it is used in such environment.

NOTE: The emissions characteristics of this equipment make it suitable for use in industrial areas and hospitals (CISPR 11 class A). If it is used in a residential environment (for which CISPR 11 class B is normally required) this equipment might not offer adequate protection to radio-frequency communication services. The user might need to take mitigation measures, such as relocating or re-orienting the equipment.

CAUTION: Interference may occur in areas where the intensity of electromagnetic disturbances is high such as near active HF surgical equipment and the RF shielded room of a medical electrical system for magnetic resonance imaging. Although these environments are typically found in hospitals they are Special Environments and are not considered part of the Professional Healthcare Facility Environment as defined in IEC 60601-1-2.

Emissions Test	Compliance Level	Electromagnetic Environment—Guidance
RF Emissions CISPR 11	Group 1	The T7 uses RF energy only for its internal functions. Therefore, its RF emissions are very low and are not likely to cause any interference with nearby electronic equipment.
RF Emissions CISPR 11	Class A	
Harmonics IEC 61000-3-2	Class A	
Flicker IEC 61000-3-3	N/A	120V AC 60 Hz input power. The T7 is suitable for use in all establishments, including domestic, and those directly connected to the public low voltage power supply network that supplies buildings used for domestic purposes.

All Equipment and Systems

12.3 GUIDANCE AND MANUFACTURER’S DECLARATION—IMMUNITY

The T7 is intended for use in the electromagnetic environment specified below. The T7 user should ensure that it is used in such an environment.

The T7 has been certified to the safety and EMC requirements of IEC 60601-1-2, 3rd and 4th editions.

Immunity Test	IEC 60601 Test Level	Compliance Level	Electromagnetic Environment—Guidance
ESD IEC 61000-4-2	±6 kV Contact ±8 kV Air	±8 kV Contact ±15 kV Air	Floors should be wood, concrete or ceramic tile. If floors are synthetic, the r/h should be at least 30%.
EFT IEC 61000-4-4	±2 kV Mains ±1 kV I/Os	±2 kV Mains I/Os N/A	Mains power quality should be that of a typical commercial or hospital environment.
Surge IEC 61000-4-5	1 kV Differential ±2 kV Common	±1 kV Differential ±2 kV Common	Mains power quality should be that of a typical commercial or hospital environment.
Voltage Dips/ Dropout IEC 61000-4-11	> 95% Dip Cycle for .05 Cycle 60% Dip Cycle for 5 Cycles 30% Dip for 25 Cycles 95% Dip for 5 seconds	> 95% Dip Cycle for .05 Cycle 60% Dip Cycle for 5 Cycles 30% Dip for 25 Cycles 95% Dip for 5 seconds	Mains power quality should be that of a typical commercial or hospital environment. If the user of the T7 requires continued operation during power mains interruptions, it is recommended that the T7 be powered from an uninterruptable power supply or battery.
Power Frequency 50/60 Hz Magnetic Field IEC 61000-4-8	30 A/m	30 A/m	Power frequency magnetic fields should be that of a typical commercial or hospital environment.

All Equipment and Systems

Immunity Test	IEC 60601 Test Level	Compliance Level	Electromagnetic Environment—Guidance
Conducted RF IEC 61000-4-6	3 Vrms 150 kHz to 80 MHz	(3) Vrms	Portable and mobile communications equipment should be separated from the T7 CART by no less than the distances calculated/ listed below:
Radiated RF IEC 61000-4-3	3 V/m 80 MHz to 2.7 GHz	(3) V/m	<p>$D=(3.5/V1)(\text{Sqrt } P)$ $D=(12/V2)(\text{Sqrt } P)$ $D=(12/E1)(\text{Sqrt } P)$</p>
			<p>80 to 800 MHz where P is the max power in watts and D is the recommended separation distance in meters. Field strengths from fixed transmitters, as determined by an electromagnetic site survey, should be less than the compliance levels (V1 and E1). Interference may occur in the vicinity of equipment containing a transmitter.</p>
			<p>$D=(23/E1)(\text{Sqrt } P)$</p>
			<p>800 MHz to 2.7 GHz where P is the max power in watts and D is the recommended separation distance in meters. Field strengths from fixed transmitters, as determined by an electromagnetic site survey, should be less than the compliance levels (V1 and E1). Interference may occur in the vicinity of equipment containing a transmitter.</p>

Equipment and Systems that are not Life-Supporting



Do not dispose of the T7 or any associated components at the end of service life. Contact Humanscale for disposal instructions.

13.0 SHIPPING AND OPERATING ENVIRONMENT

Please note these recommended environmental conditions for the transportation and operation of the T7 Point-of-Care Technology Cart. Shipping, storing or using the T7 in extreme conditions outside the recommended range may adversely affect the performance of the T7 and may void the warranty.

13.1 SHIPPING ENVIRONMENT

Storage/Shipping Temperature Range	23° to 95° F / -5° to 35° C
Storage/Shipping Relative Humidity Range	10% to 80%

13.2 OPERATING ENVIRONMENT

Operating Temperature Range	0°C to 40°C
Operating Relative Humidity	0% to 95%
Operating Elevation	0 to 3,000 meters

14.0 SYSTEM MESSAGES

Type	Message	Action to be taken
System	Clear Perimeter Before Proceeding	Ensure cart perimeter cleared before selecting "OK" to begin lifter calibration process
Error	"Cart Was Stopped! Please Select User Height"	Cart height stopped in range between sitting and standing zone: User must select "OK" and then re-enter height setting desired
System	"Pause"	Touch screen to pause movement if desired during lifter travel

System	"Please Enter User Height"	Preset Screen - User selects height to be entered for 1 of 6 presets
Error	"Cart Adjustment Was Interrupted! Clear Perimeter and Continue"	Collision Detection - User must ensure that collision hazard is removed and then select "RESUME"
Error	"Cart Adjustment Was Interrupted!" Clear Perimeter and Enter User's Height."	Collision Detection - User must ensure that collision hazard is removed, select "OK" and then re-enter desired height
System	"PowerTrack Enabled"	None

15.0 WARRANTY

For warranty and terms and conditions, please visit www.humanscale.com

16.0 FCC COMPLIANCE STATEMENT

TouchPoint T7

Note: This equipment has been tested and found to comply with the limits for a Class A digital device, pursuant to part 15 of the FCC Rules. These limits are designed to provide reasonable protection against harmful interference when the equipment is operated in a commercial environment. This equipment generates, uses, and can radiate radio frequency energy and, if not installed and used in accordance with the instruction manual, may cause harmful interference to radio communications. Operation of this equipment in a residential area is likely to cause harmful interference in which case the user will be required to correct the interference at his own expense.

Changes or modifications made to this device that are not expressly approved by Humanscale Corporation may void the user's authority to operate the equipment.

Innovation, Science and Economic Development Canada ICES-003 Compliance Notice:

This Class A digital apparatus complies with Canadian ICES-003.

Cet appareil numérique de la classe A est conforme à la norme NMB-003 du Canada.