

ARG 18083 A++

12NC: 859991030910

EAN code: 8003437041969



SENSING THE DIFFERENCE

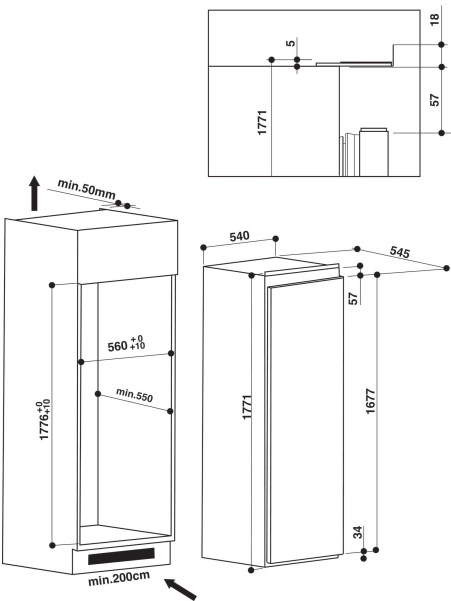

MAIN FEATURES

Product group	Refrigerator
Commercial code	ARG 18083 A++
EAN code	8003437041969
Construction type	Built-in
Installation type	Full-integrated
Type of control	Electronic
Type of control setting and signalling devices	7 segments
Main colour of product	White
Connection rating (W)	130
Current (A)	13
Voltage (V)	220-240
Frequency (Hz)	50
Length of Electrical Supply Cord (cm)	245
Plug type	UK
Total unit net capacity (l)	318
Star Rating	Automatic
Number of independent cooling systems	1
Height of the product	1771
Width of the product	540
Depth of the product	545
Depth with open door 90 degree (mm)	-
Maximum adjustability feet	0
Net weight (kg)	50
Door hinge	Right reversible

TECHNICAL FEATURES

Temperature adjustable	Yes
Warning signal / Malfunction	Visual
Defrost process fridge section	Automatic
Fast cooling switch	No
Interior ventilator fridge section	Yes
Shelves for Bottles	Yes
Lockable door	-
Number of shelves in fridge compartment	7
Number of Adjustable Shelves in fridge compartment	5
Material of the shelves	Glass
Thermometer fridge section	None

PERFORMANCES

Energy efficiency class - NEW (2010/30/EC)	A++
Energy consumption annual (kWh/annum) - NEW (2010/30/EC)	115
Refrigerator Net capacity (l) - NEW (2010/30/EC)	318
Freezer Net capacity (l) - NEW (2010/30/EC)	0
Freezing capacity (kg/24h) - NEW (2010/30/EC)	0
Temperature rise time (h)	0
Climate class	SN-T
Noise level (dB(A) re 1 pW)	34
Frost free system	No
Maximum ambient temperature	43
Minimum ambient temperature	10
Other Compartment	-