

PowerShot G1X Mark III

Camera User Guide

- Make sure you read this guide, including the “Safety Instructions” (15) section, before using the camera.
- Reading this guide will help you learn to use the camera properly.
- Store this guide safely so that you can use it in the future.
- Click the buttons in the lower right to access other pages.
 - ▶ : Next page
 - ◀ : Previous page
 - ↶ : Page before you clicked a link
- To jump to the beginning of a chapter, click the chapter title at right.

Before Use

Basic Guide

Advanced Guide

Camera Basics

Auto Mode /
Hybrid Auto Mode

Other Shooting Modes

P Mode

Tv, Av, M, and C Mode

Playback Mode

Wireless Features

Setting Menu

Accessories

Appendix

Index

ENGLISH

Before Use

Package Contents

Before use, make sure the following items are included in the package. If anything is missing, contact your camera retailer.



Camera



Battery Pack
NB-13L*

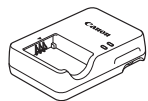

Battery Charger
CB-2LH/CB-2LHE



Neck Strap



Strap Adapter



Lens Cap



Lens Cap Cord

* Do not peel off the adhesive covering from a battery pack.

- Printed matter is also included.
- A memory card is not included (📖2).

Compatible Memory Cards

The following memory cards (sold separately) can be used, regardless of capacity.

- SD memory cards*¹
- SDHC memory cards *^{1*2}
- SDXC memory cards*^{1*2} 

*1 Cards conforming to SD standards. However, not all memory cards have been verified to work with the camera.

*2 UHS-I memory cards are also supported.

Before Use

Basic Guide

Advanced Guide

Camera Basics

Auto Mode /
Hybrid Auto Mode

Other Shooting Modes

P Mode

Tv, Av, M, and C Mode

Playback Mode

Wireless Features

Setting Menu

Accessories

Appendix







Index



Preliminary Notes and Legal Information

- Take and review some test shots initially to make sure the images were recorded correctly. Please note that Canon Inc., its subsidiaries and affiliates, and its distributors are not liable for any consequential damages arising from any malfunction of a camera or accessory, including memory cards, that result in the failure of an image to be recorded or to be recorded in a way that is machine readable.
- The user's unauthorized photographing or recording (video and/or sound) of people or copyrighted materials may invade the privacy of such people and/or may violate others' legal rights, including copyright and other intellectual property rights. Note that restrictions may apply even when such photographing or recording is intended solely for personal use.
- The camera warranty is valid only in the area of purchase. In case of camera problems while abroad, return to the area of purchase before contacting a Customer Support Help Desk.
- Although the screen (monitor) and viewfinder are produced under extremely high-precision manufacturing conditions and more than 99.99% of the pixels meet design specifications, in rare cases some pixels may be defective or may appear as red or black dots. This does not indicate camera damage or affect recorded images.
- When the camera is used over an extended period, it may become warm. This does not indicate damage.

Conventions in This Guide

- In this guide, icons are used to represent the corresponding camera buttons and dials on which they appear or which they resemble.
- The following camera buttons and controls are represented by icons. Numbers in parentheses indicate the numbers of corresponding controls in "Part Names" (4).
 -  Continuous ring (2) on front
 -  Front dial (3) on front
 -  Up button (11) on back
 -  Left button (12) on back
 -  Right button (18) on back
 -  Down button (19) on back
 -  Control dial (16) on back
- Shooting modes and on-screen icons and text are indicated in brackets.
- ⓘ: Important information you should know
- ⓘ: Notes and tips for expert camera use
- ✎: Indicates touch-screen operations
- 📖 xx: Pages with related information (in this example, "xx" represents a page number)
- Instructions in this guide apply to the camera under default settings.
- For convenience, all supported memory cards are simply referred to as the "memory card".
- The symbols "▶ Still Images" and "▶ Movies" below titles indicate how the function is used—whether for still images or movies.

Before Use

Basic Guide

Advanced Guide

Camera Basics

Auto Mode / Hybrid Auto Mode

Other Shooting Modes

P Mode

Tv, Av, M, and C Mode

Playback Mode

Wireless Features

Setting Menu

Accessories

Appendix

Index



Part Names

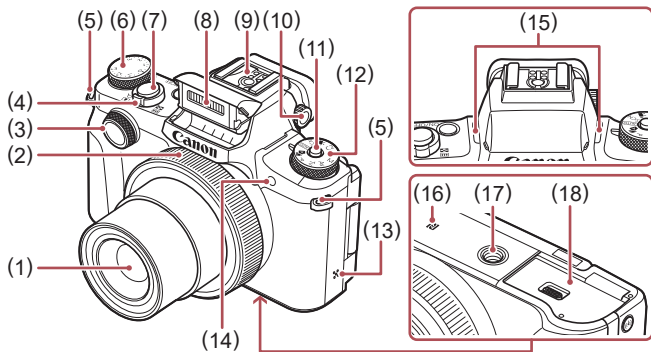

- | | |
|----------------------------------------------|--------------------------------|
| (1) Lens | (9) Hot shoe |
| (2) Continuous ring | (10) Diopter adjustment dial |
| (3) Front dial | (11) Mode dial release button |
| (4) Zoom lever | (12) Mode dial |
| Shooting: [T] (telephoto) / [W] (wide angle) | (13) Speaker |
| Playback: [Q] (magnify) / [I] (index) | (14) Lamp |
| (5) Strap mount | (15) Microphone |
| (6) Exposure compensation dial | (16) N (N-Mark)*1 |
| (7) Shutter button | (17) Tripod socket |
| (8) Flash | (18) Memory card/battery cover |

*1 Used with NFC features (144).

*2 Gestures may not be detected as easily if you apply a screen protector. In this case, increase the sensitivity of the touch-screen panel (176).

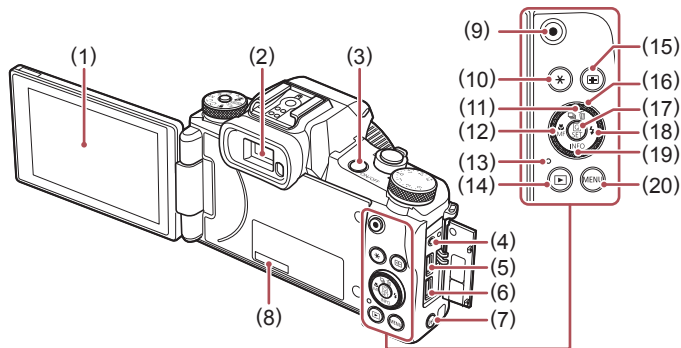

- | | |
|------------------------------------------------------|------------------------------------------------------|
| (1) Screen (monitor)*2 | (12) [M] (Macro) / [MF] (Manual focus) / Left button |
| (2) Viewfinder | (13) Indicator / USB charge lamp |
| (3) Power button | (14) [P] (Playback) button |
| (4) Remote switch terminal | (15) [AF] (AF frame selector) button |
| (5) DIGITAL terminal | (16) Control dial |
| (6) HDMI™ terminal | (17) [Q] (Quick Set menu/Set) button |
| (7) [Wi-Fi] button | (18) [Flash] / Right button |
| (8) Serial number (Body number) | (19) [INFO] (Information) / Down button |
| (9) Movie button | (20) [MENU] button |
| (10) [AE lock] button | |
| (11) [Drive mode] / [Single-image erase] / Up button | |



- You can turn the control dial to perform most of the operations possible with the [▲][▼][◀][▶] buttons, such as choosing items and switching images.

Before Use

Basic Guide

Advanced Guide

Camera Basics

Auto Mode / Hybrid Auto Mode

Other Shooting Modes

P Mode

Tv, Av, M, and C Mode

Playback Mode

Wireless Features

Setting Menu

Accessories

Appendix

Index



Table of Contents

Before Use

Package Contents	2
Compatible Memory Cards	2
Preliminary Notes and Legal Information	3
Conventions in This Guide	3
Part Names	4
Common Camera Operations	13
Safety Instructions	15

Basic Guide

Basic Operations	17
Touch-Screen Operations	17
Touching	17
Dragging	17
Initial Preparations	18
Attaching Accessories	18
Holding the Camera	18
Charging the Battery Pack	19
Inserting the Battery Pack and Your Memory Card	20
Removing the Battery Pack and Memory Card	21
Using the Screen	21
Adjusting the Screen Angle and Orientation	21
Setting the Date and Time	21
Changing the Date and Time	22
Display Language	23
Trying the Camera Out	23
Shooting (Smart Auto)	23
Playback	24
Erasing Images	25

Advanced Guide

Camera Basics	26
On/Off	26
Power-Saving Features (Auto Power Down)	27
Shutter Button	27
Viewfinder	28
Shooting Modes	29
Shooting Display Options	29
Quick Set Menu	30
Using Touch-Screen Operations to Configure Settings	30
Menu Screen	31
Touch-Screen Operations	32
On-Screen Keyboard	32
Indicator Display	33
Clock	34
Auto Mode / Hybrid Auto Mode	35
Shooting with Camera-Determined Settings	35
Shooting (Smart Auto)	35
Shooting in Hybrid Auto Mode	37
Digest Movie Playback	38
Still Images/Movies	38
Still Images	38
Movies	39
Scene Icons	39
Continuous Shooting Scenes	40
Image Stabilization Icons	41
On-Screen Frames	41
Common, Convenient Features	42
Zooming In Closer on Subjects (Digital Zoom)	42
Zooming with the Continuous Ring	42

Before Use

Basic Guide

Advanced Guide

Camera Basics

Auto Mode /
Hybrid Auto Mode

Other Shooting Modes

P Mode

Tv, Av, M, and C Mode

Playback Mode

Wireless Features

Setting Menu

Accessories

Appendix

Index



Using the Self-Timer	42
Using the Self-Timer to Avoid Camera Shake	43
Customizing the Self-Timer	43
Shooting by Touching the Screen (Touch Shutter)	44
Continuous Shooting	44
Shooting with Face ID	45
Personal Information	45
Registering Face ID Information	45
Shooting	46
Checking and Editing Registered Information	47
Overwriting and Adding Face Information	48
Erasing Registered Information	49
Image Customization Features	49
Changing the Aspect Ratio	49
Changing Image Quality	50
Capturing in RAW Format	50
Using the Menu	51
Changing Movie Image Quality	51
For NTSC Video	51
For PAL Video	52
Helpful Shooting Features	52
Using the Dual Axis Electronic Level	52
Deactivating Auto Level	53
Changing the IS Mode Settings	53
Deactivating Image Stabilization	53
Recording Movies with Subjects at the Same Size Shown before Shooting	54
Customizing Camera Operation	54
Preventing the AF-Assist Beam from Firing	54
Preventing the Red-Eye Reduction Lamp from Lighting Up	55
Changing the Image Display Style after Shots	55

Other Shooting Modes	56
Specific Scenes	56
Using Functions for Underwater Shots	58
Shooting with an Underwater Focus Range	58
Correcting White Balance	58
Applying Special Effects	59
Shooting Yourself under Optimal Settings (Self Portrait)	59
Making Skin Look Smoother (Smooth Skin)	60
Shooting Panoramas (Panoramic Shot)	60
Conveying a Sense of Speed by Blurring the Background (Panning)	61
Shooting in Monochrome (Grainy B/W)	62
Shooting with a Soft Focus Effect	62
Shooting with a Fish-Eye Lens Effect (Fish-Eye Effect)	63
Shots Resembling Oil Paintings (Art Bold Effect)	63
Shots Resembling Watercolors (Water Painting Effect)	64
Shooting with a Toy Camera Effect (Toy Camera Effect)	64
Shots Resembling Miniature Models (Miniature Effect)	65
Playback Speed and Estimated Playback Time (for One-Minute Clips)	65
Shooting High-Contrast Scenes (High Dynamic Range)	66
Adding Artistic Effects	66
Special Modes for Other Purposes	67
Shooting Starry Skies (Star)	67
Shooting Night Scenes under Starry Skies (Star Nightscape)	67
Shooting Star Trails (Star Trails)	67
Recording Movies of Star Movement (Star Time-Lapse Movie)	68
Adjusting Colors	70
Adjusting the Focus	71

Before Use

Basic Guide

Advanced Guide

Camera Basics

Auto Mode /
Hybrid Auto Mode

Other Shooting Modes

P Mode

Tv, Av, M, and C Mode

Playback Mode

Wireless Features

Setting Menu

Accessories

Appendix

Index



Recording Various Movies.....	72
Recording Movies in [P] Mode.....	72
Locking or Changing Image Brightness	72
Disabling Auto Slow Shutter	73
Correcting Severe Camera Shake.....	73
Sound Settings	74
Deactivating the Wind Filter	74
Using the Attenuator	74
Recording Short Clips.....	74
Playback Effects	74
Recording Time-Lapse Movies (Time-Lapse Movie)	75
P Mode	77
Shooting in Program AE ([P] Mode).....	77
Image Brightness (Exposure).....	78
Adjusting Image Brightness (Exposure Compensation).....	78
Deactivating Exposure Simulation.....	78
Locking Image Brightness / Exposure (AE Lock)	78
Changing the Metering Method	79
Linking the Spot AE Point Frame to the AF Frame.....	79
Changing the ISO Speed.....	80
Adjusting ISO Auto Settings	80
Changing the Noise Reduction Level (High ISO speed NR)	80
Auto Exposure Bracketing (AEB Shooting)	81
Adjusting Auto ND Filter Settings	81
Auto Correction of Brightness and Contrast (Auto Lighting Optimizer).....	82
Shooting Bright Subjects (Highlight Tone Priority).....	82
Image Colors	83
Capturing Natural Colors (White Balance)	83
Custom White Balance.....	83
Manually Correcting White Balance	84
Manually Setting White Balance Color Temperature	85

Customizing Colors (Picture Style).....	85
Customizing Picture Styles.....	86
Saving Customized Picture Styles	87
Shooting Range and Focusing.....	88
Shooting at Preset Focal Lengths (Step Zoom)	88
Shooting Close-Ups (Macro)	88
Shooting in Manual Focus Mode.....	89
Easily Identifying the Focus Area (MF Peaking).....	90
Focus Bracketing (Focus-BKT Mode)	90
Digital Tele-Converter	91
Choosing the AF Method	91
1-point AF	91
Moving and Resizing AF Frames (1-point AF).....	91
AF+Tracking.....	92
Smooth Zone AF	92
Shooting with Servo AF	93
Changing the Focus Setting	93
Fine-Tuning the Focus.....	94
Choosing a Person to Focus On (Face Select).....	94
Choosing Subjects to Focus On (Touch AF).....	95
Shooting with AF Lock.....	95
Flash.....	96
Changing the Flash Mode	96
Auto	96
On.....	96
Slow Synchro	96
Off.....	96
Adjusting the Flash Exposure Compensation.....	97
Shooting with FE Lock.....	97
Changing the Flash Timing.....	98
Other Settings	98
Changing the IS Mode Settings.....	98

Before Use

Basic Guide

Advanced Guide

Camera Basics

Auto Mode /
Hybrid Auto Mode

Other Shooting Modes

P Mode

Tv, Av, M, and C Mode

Playback Mode

Wireless Features

Setting Menu

Accessories

Appendix

Index



Tv, Av, M, and C Mode	99
Specific Shutter Speeds ([Tv] Mode).....	99
Specific Aperture Values ([Av] Mode).....	100
Specific Shutter Speeds and Aperture Values ([M] Mode) ...	100
Shooting Long Exposures (Bulb).....	101
Adjusting the Flash Output.....	102
Recording Movies at Specific Shutter Speeds and Aperture Values.....	102
Customizing Controls and Display	103
Customizing Display Information.....	103
Customizing the Information Displayed.....	104
Configuring Touch & Drag AF	104
Changing the Settings of Touch and Drag Operations	105
Restricting the Area of the Screen Available for Touch and Drag Operations	105
Assigning Functions to Controls.....	105
Customizing the Quick Set Menu.....	107
Choosing Items to Include in the Menu	107
Rearranging Menu Items.....	107
Saving Shooting Settings	108
Settings That Can Be Saved	108
Saving Commonly Used Shooting Menu Items (My Menu).....	109
Renaming My Menu Tabs.....	110
Deleting a My Menu Tab.....	110
Deleting All My Menu Tabs or Items	110
Customizing My Menu Tab Display	110
Playback Mode	111
Playback.....	111
Touch-Screen Operations.....	112
Switching Display Modes.....	113
Customizing the Shooting Information Displayed.....	113

Overexposure Warning (for Image Highlights)	113
Histogram	113
RGB Histogram, GPS Information Display.....	113
Viewing Short Movies Created When Shooting Still Images (Digest Movies).....	114
Viewing by Date.....	114
Checking People Detected in Face ID.....	115
Browsing and Filtering Images	115
Navigating through Images in an Index.....	115
Touch-Screen Operations.....	116
Finding Images Matching Specified Conditions.....	116
Using the Front Dial to Jump between Images.....	117
Touch-Screen Operations.....	117
Viewing Individual Images in a Group	118
Editing Face ID Information.....	119
Changing Names.....	119
Erasing Names	119
Image Viewing Options	120
Magnifying Images	120
Touch-Screen Operations.....	120
Double-Touch Magnification	120
Viewing Slideshows.....	121
Protecting Images	121
Using the Menu	121
Choosing Images Individually.....	122
Selecting a Range	122
Protecting All Images at Once	123
Clearing All Protection at Once	123
Erasing Images	123
Erasing Multiple Images at Once.....	124
Choosing a Selection Method	124
Choosing Images Individually.....	124

Before Use

Basic Guide

Advanced Guide

Camera Basics

Auto Mode / Hybrid Auto Mode

Other Shooting Modes

P Mode

Tv, Av, M, and C Mode

Playback Mode

Wireless Features

Setting Menu

Accessories

Appendix

Index



Selecting a Range	125
Specifying All Images at Once	125
Rotating Images	125
Using the Menu	125
Deactivating Auto Rotation	126
Tagging Images as Favorites	126
Using the Menu	126
Convenient Control: Touch Actions	127
Using Touch Actions Functions	127
Changing Touch Actions Functions	127
Assignable Functions	128
Editing Still Images	128
Resizing Images	128
Using the Menu	129
Cropping	129
Applying Filter Effects	130
Correcting Red-Eye	131
Processing RAW Images with the Camera	132
Using the Menu	133
Choosing Images Individually	133
Selecting a Range	133
Editing Movies	134
Reducing File Sizes	135
Image Quality of Compressed Movies	135
Erasing Movie Chapters	135
Viewing Albums (Story Highlights)	136
Choosing Themes for Albums	136
Adding Background Music to Albums	137
Creating Your Own Albums	138
Combining Short Clips	139

Wireless Features	141
Available Wireless Features	141
Using Wi-Fi Features	141
Using Bluetooth® Features	141
Sending Images to a Smartphone	142
Sending Images to a Bluetooth Enabled Smartphone	142
Sending Images to an NFC-Compatible Smartphone	144
Connecting via NFC When Camera Is Off or in Shooting Mode	144
Connecting via NFC in Playback Mode	145
Connecting to a Smartphone via the Wi-Fi Menu	146
Using Another Access Point	147
Previous Access Points	148
Saving Images to a Computer	149
Preparing to Register a Computer	149
Installing CameraWindow	149
Configuring the Computer for a Wi-Fi Connection (Windows Only)	149
Saving Images to a Connected Computer	150
Confirming Access Point Compatibility	150
Using WPS-Compatible Access Points	151
Connecting to Listed Access Points	153
Previous Access Points	153
Sending Images to a Registered Web Service	154
Registering Web Services	154
Registering CANON iIMAGE GATEWAY	154
Registering Other Web Services	156
Uploading Images to Web Services	156
Printing Images Wirelessly from a Connected Printer	157
Sending Images to Another Camera	159
Image Sending Options	160

Before Use

Basic Guide

Advanced Guide

Camera Basics

Auto Mode /
Hybrid Auto Mode

Other Shooting Modes

P Mode

Tv, Av, M, and C Mode

Playback Mode

Wireless Features

Setting Menu

Accessories

Appendix

Index



Sending Multiple Images	160
Choosing Images Individually	160
Selecting a Range	160
Sending Favorite Images	161
Notes on Sending Images	161
Choosing the Number of Recording Pixels (Image Size)	162
Adding Comments	162
Sending Images Automatically (Image Sync).....	162
Initial Preparations	162
Preparing the Camera	162
Preparing the Computer	163
Sending Images.....	163
Viewing Images Sent via Image Sync on a Smartphone.....	164
Using a Smartphone to View Camera Images and Control the Camera.....	164
Geotagging Images When You Shoot	164
Controlling the Camera Remotely from a Smartphone.....	165
Controlling the Camera via Wi-Fi	165
Controlling the Camera via Bluetooth.....	166
Editing or Erasing Wi-Fi Settings.....	167
Editing Connection Information	167
Changing a Device Nickname	167
Erasing Connection Information	167
Specifying Images Viewable from Smartphones	168
Changing the Camera Nickname	168
Returning the Wireless Settings to Default.....	169
Clearing Information of Devices Paired via Bluetooth	169
Setting Menu.....	170
Adjusting Basic Camera Functions	170
Date-Based Image Storage	170
File Numbering	170

Formatting Memory Cards	171
Low-Level Formatting	171
Changing the Video System	172
Electronic Level Calibration	172
Resetting the Electronic Level.....	172
Switching the Color of Screen Information	172
Using Eco Mode	173
Power-Saving Adjustment	173
Screen Brightness	173
World Clock	174
Date and Time	174
Lens Retraction Timing.....	174
Display Language.....	175
Silencing Camera Operations.....	175
Adjusting the Volume.....	175
Customizing Sounds.....	175
Start-Up Screen.....	175
Hiding Hints and Tips.....	176
Listing Shooting Modes by Icon.....	176
Adjusting the Touch-Screen Panel	176
Metric / Non-Metric Display	176
Checking Certification Logos.....	176
Setting Copyright Information to Record in Images.....	177
Deleting All Copyright Information	177
Adjusting Other Settings.....	177
Restoring Default Camera Settings	177
Restoring All Camera Defaults	177
Restoring Defaults for Individual Functions.....	178
Accessories	179
System Map	180
Optional Accessories.....	181
Power Supplies.....	181

Before Use

Basic Guide

Advanced Guide

Camera Basics

Auto Mode /
Hybrid Auto Mode

Other Shooting Modes

P Mode

Tv, Av, M, and C Mode

Playback Mode

Wireless Features

Setting Menu

Accessories

Appendix

Index



Flash Units.....	181
Other Accessories	182
Printers	182
Photo and Movie Storage.....	182
Using Optional Accessories.....	183
Playback on a TV	183
Charging via USB.....	184
Using a Computer to Charge the Battery	185
Using a Lens Hood (Sold Separately)	185
Using a Remote Switch (Sold Separately)	186
Using a Timer Remote Controller (Sold Separately)	186
Using an External Flash (Sold Separately).....	187
Speedlite EX Series	187
Using Speedlite Bracket SB-E2 (Sold Separately).....	188
Camera Settings Available with an External Flash (Sold Separately).....	188
Using the Software.....	189
Computer Connections via a Cable.....	189
Checking Your Computer Environment	189
Installing the Software	189
Saving Images to a Computer.....	189
Printing Images	191
Easy Print	191
Configuring Print Settings.....	192
Cropping Images before Printing.....	192
Choosing Paper Size and Layout before Printing	193
Available Layout Options.....	193
Printing ID Photos	193
Printing Movie Scenes.....	194
Movie Printing Options	194
Adding Images to the Print List (DPOF).....	194
Configuring Print Settings.....	195

Setting Up Printing for Individual Images	195
Setting Up Printing for a Range of Images.....	196
Setting Up Printing for All Images.....	196
Clearing All Images from the Print List	196
Printing Images Added to the Print List (DPOF).....	196
Adding Images to a Photobook	197
Choosing a Selection Method	197
Adding Images Individually.....	197
Adding All Images to a Photobook	197
Removing All Images from a Photobook	197
Appendix.....	198
Troubleshooting.....	198
On-Screen Messages.....	202
On-Screen Information	204
Shooting (Information Display)	204
Battery Level	204
During Playback	205
Info Display 1.....	205
Info Display 2.....	205
Info Display 3.....	206
Info Display 4.....	206
Info Display 5.....	206
Summary of Movie Control Panel.....	206
Functions and Menu Tables	207
Functions Available in Each Shooting Mode	207
Quick Set Menu.....	209
Shooting Tab.....	212
Set Up Tab.....	221
My Menu Tab	221
Playback Tab	222
Handling Precautions	222

Before Use

Basic Guide

Advanced Guide

Camera Basics

Auto Mode /
Hybrid Auto Mode

Other Shooting Modes

P Mode

Tv, Av, M, and C Mode

Playback Mode

Wireless Features

Setting Menu

Accessories

Appendix

Index



Specifications	223
Image Sensor	223
Lens	223
Shutter	223
Aperture	223
Flash	223
Viewfinder/Monitor	223
Shooting	224
Recording	224
Power	225
Interface	225
Operating Environment	226
Dimensions (CIPA Compliant)	226
Weight (CIPA Compliant)	226
Battery Pack NB-13L	226
Battery Charger CB-2LH/CB-2LHE	226
Compact Power Adapter CA-DC30/CA-DC30E	226
Index	227
Precautions for Wireless Features (Wi-Fi, Bluetooth, or Others)	229
Radio Wave Interference Precautions	229
Security Precautions	229
Third-Party Software	230
Personal Information and Security Precautions	231
Trademarks and Licensing	231
Disclaimer	231

Before Use

Basic Guide

Advanced Guide

Camera Basics

Auto Mode /
Hybrid Auto Mode

Other Shooting Modes

P Mode

Tv, Av, M, and C Mode

Playback Mode

Wireless Features

Setting Menu

Accessories

Appendix

Index



Common Camera Operations

Shoot

- Use camera-determined settings (Auto Mode, Hybrid Auto Mode)
 - 35, 37
- Shoot yourself under optimal settings (Self Portrait)
 - 59
- Shoot panoramas (Panoramic Shot)
 - 60

Shooting people well



Matching specific scenes



Handheld Night Scene
(56)



Under Water
(56)



Fireworks
(56)



Starry Skies
(67)

Applying special effects



Smooth Skin
(60)



Monochrome
(62)



Soft Focus
(62)



Fish-Eye Effect
(63)



Like Oil Paintings
(63)



Like Watercolor Paintings
(64)



Toy Camera Effect
(64)



Miniature Effect
(65)

- Focus on faces
 - 35, 56, 92, 94
- Without using the flash (Flash Off)
 - 35
- Include yourself in the shot (Self-Timer)
 - 42
- Movie clips and photos together (Movie Digest)
 - 37
- Convey a sense of speed with a blurred background
 - 61

Before Use

Basic Guide

Advanced Guide

Camera Basics

Auto Mode /
Hybrid Auto Mode

Other Shooting Modes

P Mode

Tv, Av, M, and C Mode

Playback Mode

Wireless Features

Setting Menu







Accessories

Appendix





Index



View

- View images (Playback Mode)
 -  111
- Automatic playback (Slideshow)
 -  121
- On a TV
 -  183
- On a computer
 -  189
- Browse through images quickly
 -  115
- Erase images
 -  123
- Create an album automatically
 -  136

Record/View Movies

- Record movies
 -  35,  72,  102
- View movies (Playback Mode)
 -  111



Print

- Print pictures
 -  191

Save

- Save images to a computer
 -  189

Using Wi-Fi Features

- Send images to a smartphone
 -  142
- Share images online
 -  154
- Send images to a computer
 -  162

Before Use

Basic Guide

Advanced Guide

Camera Basics

Auto Mode / Hybrid Auto Mode

Other Shooting Modes

P Mode

Tv, Av, M, and C Mode

Playback Mode

Wireless Features

Setting Menu

Accessories

Appendix

Index



Safety Instructions

Be sure to read these instructions in order to operate the product safely. Follow these instructions to prevent injury or harm to the operator of the product or others.



WARNING

Denotes the risk of serious injury or death.

- Keep the product out of the reach of young children. A strap wrapped around a person's neck may result in strangulation.
- Use only power sources specified in this instruction manual for use with the product.
- Do not disassemble or modify the product.
- Do not expose the product to strong shocks or vibration.
- Do not touch any exposed internal parts.
- Stop using the product in any case of unusual circumstances such as the presence of smoke or a strange smell.
- Do not use organic solvents such as alcohol, benzine or paint thinner to clean the product.
- Do not get the product wet. Do not insert foreign objects or liquids into the product.
- Do not insert foreign objects or liquids into the product.
- Do not use the product where flammable gases may be present. This may cause electric shock, explosion or fire.
- For products featuring a viewfinder, do not look through the viewfinder at strong light sources such as the sun on a bright day or lasers and other strong artificial light sources. This may harm your vision.

- Observe the following instructions when using commercially available batteries or provided battery packs.
 - Use batteries/battery packs only with their specified product.
 - Do not heat batteries/battery packs or expose them to fire.
 - Do not charge batteries/battery packs using non-authorized battery chargers.
 - Do not expose the terminals to dirt or let them come into contact with metallic pins or other metal objects.
 - Do not use leaking batteries/battery packs.
 - When disposing of batteries/battery packs, insulate the terminals with tape or other means.

This may cause electric shock, explosion or fire. If a battery/battery pack leaks and the material contacts your skin or clothing, flush the exposed area thoroughly with running water. In case of eye contact, flush thoroughly with copious amounts of clean running water and seek immediate medical assistance.

- Observe the following instructions when using a battery charger or AC adapter.
 - Periodically remove any dust buildup from the power plug and power outlet using a dry cloth.
 - Do not plug in or unplug the product with wet hands.
 - Do not use the product if the power plug is not fully inserted into the power outlet.
 - Do not expose the power plug and terminals to dirt or let them come into contact with metallic pins or other metal objects.
- Do not touch the battery charger or AC adapter connected to a power outlet during lightning storms.
- Do not place heavy objects on the power cord. Do not damage, break or modify the power cord.
- Do not wrap the product in cloth or other materials when in use or shortly after use when the product is still warm in temperature.
- Do not leave the product connected to a power source for long periods of time.

This may cause electric shock, explosion or fire.

Before Use

Basic Guide

Advanced Guide

Camera Basics

Auto Mode /
Hybrid Auto Mode

Other Shooting Modes

P Mode

Tv, Av, M, and C Mode

Playback Mode

Wireless Features

Setting Menu

Accessories

Appendix

Index



- Do not allow the product to maintain contact with the same area of skin for extended periods of time during use.

This may result in low-temperature contact burns, including skin redness and blistering, even if the product does not feel hot. The use of a tripod or similar equipment is recommended when using the product in hot places and for people with circulation problems or less sensitive skin.

- Follow any indications to turn off the product in places where its use is forbidden.

Not doing so may cause other equipment to malfunction due to the effect of electromagnetic waves and even result in accidents.

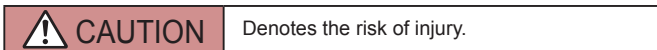

Denotes the risk of injury.

- Do not fire the flash near the eyes. It may hurt the eyes.
- Strap is intended for use on the body only. Hanging the strap with any product attached on a hook or other object may damage the product. Also, do not shake the product or expose the product to strong impacts.
- Do not apply strong pressure on the lens or allow an object to hit it. This may cause injury or damage to the product.
- Flash emits high temperatures when fired. Keep fingers, any other part of your body, and objects away from the flash unit while taking pictures. This may cause burns or malfunction of the flash.
- Do not leave the product in places exposed to extremely high or low temperatures. The product may become extremely hot/cold and cause burns or injury when touched.

CAUTION

Denotes the possibility of property damage.

- Do not aim the camera at intense light sources, such as the sun on a clear day or an intense artificial light source. Doing so may damage the image sensor or other internal components.

- When using the camera on a sandy beach or at a windy location, be careful not to allow dust or sand to enter the camera.

- Wipe off any dust, grime, or other foreign matter on the flash with a cotton swab or cloth. The heat emitted from the flash may cause foreign matter to smoke or the product to malfunction.

- Remove and store the battery pack/batteries when you are not using the product. Any battery leakage that occurs may cause product damage.

- Before you discard the battery pack/batteries, cover the terminals with tape or other insulators. Contacting other metal materials may lead to fire or explosions.

- Unplug any battery charger used with the product when not in use. Do not cover with a cloth or other objects when in use. Leaving the unit plugged in for a long period of time may cause it to overheat and distort, resulting in fire.

- Do not leave any dedicated battery packs near pets. Pets biting the battery pack could cause leakage, overheating, or explosion, resulting in product damage or fire.

- If your product uses multiple batteries, do not use batteries that have different levels of charge together, and do not use old and new batteries together. Do not insert the batteries with the + and – terminals reversed. This may cause the product to malfunction.

Before Use

Basic Guide

Advanced Guide

Camera Basics

Auto Mode / Hybrid Auto Mode

Other Shooting Modes

P Mode

Tv, Av, M, and C Mode

Playback Mode

Wireless Features

Setting Menu

Accessories

Appendix

Index



Basic Guide

Basic Operations

Basic information and instructions, from initial preparations to shooting and playback

Touch-Screen Operations

The camera's touch-screen panel enables intuitive operation simply by touching or tapping the screen.

Touching



Touch the screen briefly with your finger.

- This gesture is used to shoot, configure camera functions, and so on.

Dragging

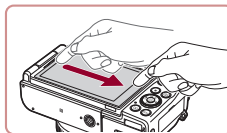

Touch the screen and move your finger across it.

- This gesture is used in Playback mode to switch to the next image, or to change the magnified image area, among other operations.

Before Use

Basic Guide

Advanced Guide

Camera Basics

Auto Mode /
Hybrid Auto Mode

Other Shooting Modes

P Mode

Tv, Av, M, and C Mode

Playback Mode

Wireless Features

Setting Menu

Accessories

Appendix

Index



Initial Preparations

Prepare for shooting as follows.

Attaching Accessories

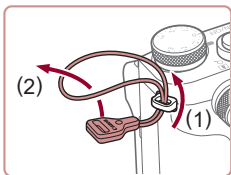

1 Attach the strap adapter.

- Attach the included strap adapter to the camera as shown.
- On the other side of the camera, attach the strap adapter the same way.

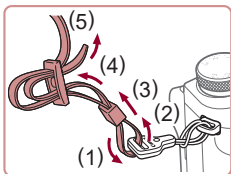

2 Attach the strap.

- Attach the included strap to the strap adapter as shown.
- On the other side of the camera, attach the strap the same way.

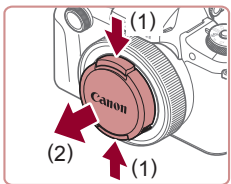

3 Attach the lens cap.

- Remove the lens cap from the lens momentarily.

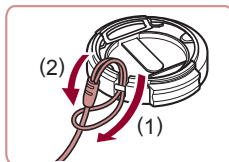

- Thread the smaller loop through the lens cap to attach it as shown, and then attach the lens cap cord to the strap.

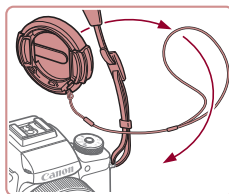

- Always remove the lens cap before turning the camera on. Try clipping the lens cap to the strap when the cap is not in use.
- Keep the lens cap on the lens when the camera is not in use.

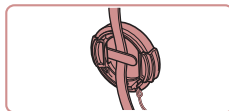

Holding the Camera



- Place the strap around your neck.
- When shooting, keep your arms close to your body and hold the camera securely to prevent it from moving. If you have raised the flash, do not rest your fingers on it.

Before Use

Basic Guide

Advanced Guide

Camera Basics

Auto Mode /
Hybrid Auto Mode

Other Shooting Modes

P Mode

Tv, Av, M, and C Mode

Playback Mode

Wireless Features

Setting Menu

Accessories

Appendix

Index



Charging the Battery Pack

Before use, charge the battery pack with the included charger. Be sure to charge the battery pack initially, because the camera is not sold with the battery pack charged.

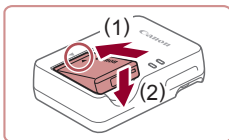

1 Insert the battery pack.

- After aligning the ▲ marks on the battery pack and charger, insert the battery pack by pushing it in (1) and down (2).

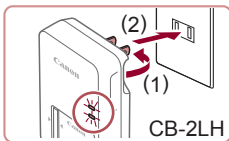

2 Charge the battery pack.

- **CB-2LH:** Flip out the plug (1) and plug the charger into a power outlet (2).
- **CB-2LHE:** Plug the power cord into the charger, then plug the other end into a power outlet.
- The charging lamp turns orange, and charging begins.
- When charging is finished, the lamp turns green.

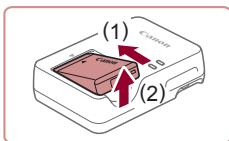
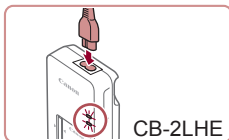

3 Remove the battery pack.

- After unplugging the battery charger, remove the battery pack by pushing it in (1) and up (2).



- To protect the battery pack and keep it in optimal condition, do not charge it continuously for more than 24 hours.
- For battery chargers that use a power cord, do not attach the charger or cord to other objects. Doing so could result in malfunction or damage to the product.
- The charger can be used in areas with 100 – 240 V AC power (50/60 Hz). For power outlets in a different format, use a commercially available adapter for the plug. Never use an electrical transformer designed for traveling, which may damage the battery pack.



- For details on charging time and the number of shots and recording time possible with a fully charged battery pack, see "Power" (P.225).
- Charged battery packs gradually lose their charge, even when they are not used. Charge the battery pack on (or immediately before) the day of use.
- As a visual reminder of the charge status, attach the battery cover with ▲ visible on a charged battery pack and concealed on an uncharged one.

Before Use

Basic Guide

Advanced Guide

Camera Basics

Auto Mode /
Hybrid Auto Mode

Other Shooting Modes

P Mode

Tv, Av, M, and C Mode

Playback Mode

Wireless Features

Setting Menu

Accessories

Appendix

Index



Inserting the Battery Pack and Your Memory Card

Insert the included battery pack and a memory card (sold separately). Note that before using a memory card that is new or has been formatted in another device, you should format the memory card with this camera (171).

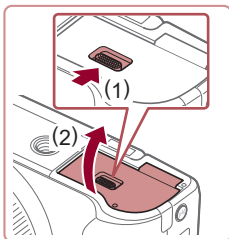

1 Open the cover.

- Slide the switch (1) and open the cover (2).

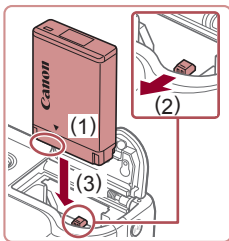

2 Insert the battery pack.

- Holding the battery pack with the terminals in the position shown (1), hold the battery lock toward (2) and insert the battery pack toward (3) until the lock clicks shut.
- If you insert the battery pack facing the wrong way, it cannot be locked into the correct position. Always confirm that the battery pack is facing the right way and locks when inserted.

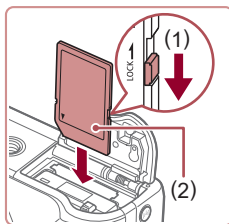

3 Check your card's write-protect switch and insert the memory card.

- Recording is not possible on memory cards with a write-protect switch when the switch is in the locked position. Move the switch toward (1).
- Insert the memory card with the label (2) facing as shown until it clicks into place.
- Make sure the memory card is facing the right way when you insert it. Inserting memory cards facing the wrong way may damage the camera.

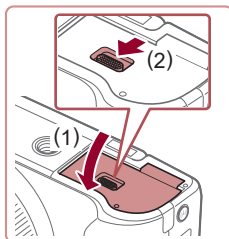

4 Close the cover.

- Lower the cover (1) and hold it down as you slide the switch, until it clicks into the closed position (2).

Before Use

Basic Guide

Advanced Guide

Camera Basics

Auto Mode /
Hybrid Auto Mode

Other Shooting Modes

P Mode

Tv, Av, M, and C Mode

Playback Mode

Wireless Features

Setting Menu

Accessories

Appendix

Index



Removing the Battery Pack and Memory Card

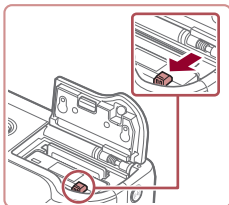

Remove the battery pack.

- Open the cover and press the battery lock in the direction of the arrow.
- The battery pack will pop up.

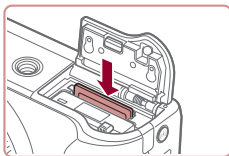

Remove the memory card.

- Push the memory card in until it clicks, and then slowly release it.
- The memory card will pop up.

Using the Screen

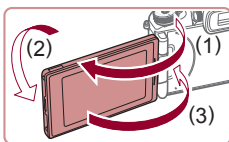

- Open the screen (1) and rotate it toward the lens 180° (2).
- Close the screen in this orientation (3).



- The screen can only open to approximately 180° in direction (1). Be careful not to open the screen any further than this, as it will damage the camera.

Adjusting the Screen Angle and Orientation

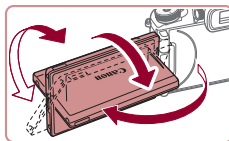

- You can adjust the angle and orientation of the screen as needed, to suit shooting conditions.
- To protect the screen when the camera is not in use, always keep it closed and facing the camera body.



- Open the screen to activate it when the camera is on. This will deactivate the viewfinder. Similarly, close the screen (facing the camera body) to deactivate it and activate the viewfinder.
- When including yourself in shots, you can view a mirror image of yourself by rotating the screen around toward the front of the camera. To cancel reverse display, press the [MENU] button, choose [Reverse Display] on the [CAMERA] tab, press the [OK] button, and then press the [▲][▼] buttons to choose [Off].

Setting the Date and Time

Set the current date and time correctly as follows if the [Date/Time] screen is displayed when you turn the camera on. Information you specify this way is recorded in image properties when you shoot, and it is used when you manage images by shooting date or print images showing the date.

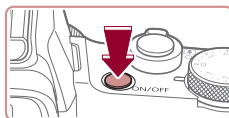

1 Turn the camera on.

- Press the power button.
- The [Date/Time] screen is displayed.

Before Use

Basic Guide

Advanced Guide

Camera Basics

Auto Mode /
Hybrid Auto Mode

Other Shooting Modes

P Mode

Tv, Av, M, and C Mode

Playback Mode

Wireless Features

Setting Menu

Accessories

Appendix

Index



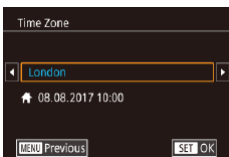
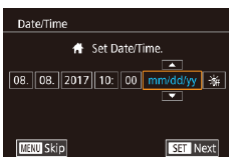

2 Set the date and time.

- Press the [◀][▶] buttons to choose an item.
- Press the [▲][▼] buttons or turn the [DISP] dial to specify the date and time.
- When finished, press the [SET] button.

3 Specify your home time zone.

- Press the [◀][▶] buttons to choose your home time zone.

4 Finish the setup process.

- Press the [SET] button when finished. After a confirmation message, the setting screen is no longer displayed.
- To turn off the camera, press the power button.



- Unless you set the date, time, and home time zone, the [Date/Time] screen will be displayed each time you turn the camera on. Specify the correct information.



- To set daylight saving time (1 hour ahead), choose [☀] in step 2 and then choose [☀] by pressing the [▲][▼] buttons or turning the [DISP] dial.



- You can also set the date and time by touching the desired item on the screen in step 2 and then touching [▲][▼], followed by [SET]. Similarly, you can also set your home time zone by touching [◀][▶] on the screen in step 3, followed by [SET].

Changing the Date and Time

Adjust the date and time as follows.

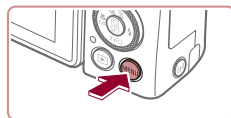

1 Access the menu screen.

- Press the [MENU] button.

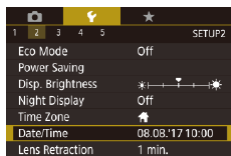

2 Choose [Date/Time].

- Press the [◀][▶] buttons or turn the [DISP] dial to choose [Date/Time] tab.
- Press the [▲][▼] buttons or turn the [DISP] dial to choose [Date/Time], and then press the [SET] button.

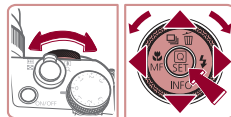

3 Change the date and time.

- Follow step 2 in “Setting the Date and Time” (📖21) to adjust the settings.
- Press the [MENU] button to close the menu screen.



- Date/time settings can be retained for about 3 weeks by the camera's built-in date/time battery (backup battery) after the battery pack is removed.
- The date/time battery will be charged in about 4 hours once you insert a charged battery pack, even if the camera is left off.
- Once the date/time battery is depleted, the [Date/Time] screen will be displayed when you turn the camera on. Set the correct date and time as described in “Setting the Date and Time” (📖21).

Before Use

Basic Guide

Advanced Guide

Camera Basics

Auto Mode /
Hybrid Auto Mode

Other Shooting Modes

P Mode

Tv, Av, M, and C Mode

Playback Mode

Wireless Features

Setting Menu

Accessories

Appendix

Index



Display Language

Change the display language as needed.

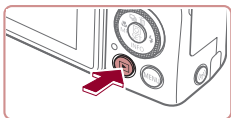

1 Enter Playback mode.

- Press the [▶] button.

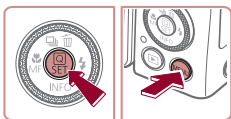

2 Access the setting screen.

- Press and hold the [ⓘ] button, and then immediately press the [MENU] button.

English	Norsk	Română
Deutsch	Svenska	Türkçe
Français	Español	العربية
Nederlands	Ελληνικά	Հայերեն
Dansk	Русский	繁體中文
Português	Polski	繁體中文
Suomi	Čeština	한국어

3 Set the display language.

- Press the [▲][▼][◀][▶] buttons or turn the [ⓘ] dial to choose a language, and then press the [ⓘ] button.
- Once the display language has been set, the setting screen is no longer displayed.



- The current time is displayed if you wait too long in step 2 after pressing the [ⓘ] button before you press the [MENU] button. In this case, press the [ⓘ] button to dismiss the time display and repeat step 2.
- You can also change the display language by pressing the [MENU] button and choosing [Language] on the [3] tab.



- You can also set the display language by touching a language on the screen in step 3 and then touching it again.

Trying the Camera Out

▶ Still Images ▶ Movies

Try out the camera by turning it on, shooting some still images or movies, and viewing them.

Shooting (Smart Auto)

For fully automatic selection of the optimal settings for specific scenes, simply let the camera determine the subject and shooting conditions.

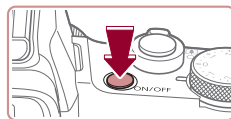

1 Turn the camera on.

- Press the power button.
- The startup screen is displayed.

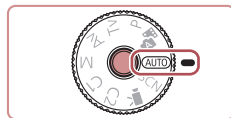

2 Enter [AUTO] mode.

- Hold down the mode dial release button and turn the mode dial to [AUTO].
- Aim the camera at the subject. The camera will make a slight clicking noise as it determines the scene.
- Icons representing the scene and image stabilization mode are displayed in the upper left of the screen.
- Frames displayed around any detected subjects indicate that they are in focus.

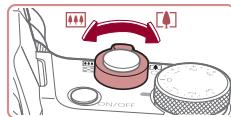

3 Zoom in or out, as needed.

- To zoom in and enlarge the subject, move the zoom lever toward [T] (telephoto), and to zoom away from the subject, move it toward [W] (wide angle).

Before Use

Basic Guide

Advanced Guide

Camera Basics

Auto Mode / Hybrid Auto Mode

Other Shooting Modes

P Mode

Tv, Av, M, and C Mode

Playback Mode

Wireless Features

Setting Menu

Accessories

Appendix

Index



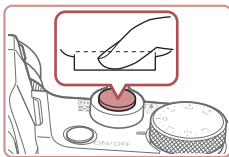
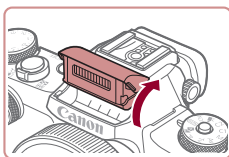
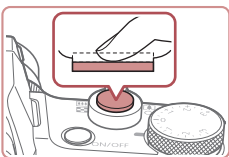

4 Shoot.

Shooting Still Images

1) Focus.

- Press the shutter button lightly, halfway down. The camera beeps twice after focusing, and frames are displayed to indicate image areas in focus.

- If [Raise the flash] is displayed, lift the flash with your fingers. It will fire when shooting. If you prefer not to use the flash, push it down with your finger, into the camera.

2) Shoot.

- Press the shutter button all the way down.
- As the camera shoots, a shutter sound is played, and in low-light conditions when you have raised the flash, it fires automatically.
- Keep the camera still until the shutter sound ends.
- After displaying your shot, the camera will revert to the shooting screen.



(1)



Recording Movies

1) Start recording.

- Press the movie button. The camera beeps once as recording begins, and [●Rec] is displayed with the elapsed time (1).
- Black bars are displayed on the top and bottom edges of the screen, and the subject is slightly enlarged. The black bars indicate image areas not recorded.
- Frames displayed around any detected faces indicate that they are in focus.
- Once recording begins, take your finger off the movie button.

2) Stop recording.

- Press the movie button again to stop recording. The camera beeps twice as recording stops.

Playback

After shooting images or movies, you can view them on the screen as follows.

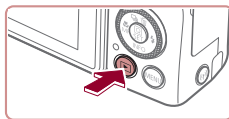

1 Enter Playback mode.

- Press the [▶] button.
- Your last shot is displayed.

Before Use

Basic Guide

Advanced Guide

Camera Basics

Auto Mode /
Hybrid Auto Mode

Other Shooting Modes

P Mode

Tv, Av, M, and C Mode

Playback Mode

Wireless Features

Setting Menu

Accessories

Appendix

Index





2 Choose images.

- To view the previous image, press the [◀] button or turn the [DISP] dial counterclockwise. To view the next image, press the [▶] button or turn the [DISP] dial clockwise.
- Press and hold the [◀][▶] buttons to browse through images quickly.

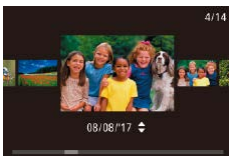

- To access this screen (Scroll Display mode), turn the [DISP] dial rapidly. In this mode, turn the [DISP] dial to browse through images.
- To return to single-image display, press the [DISP] button.

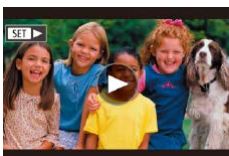

- Movies are identified by a [SET] ▶ icon. To play movies, go to step 3.



3 Play movies.

- Press the [DISP] button, press the [▲][▼] buttons to choose [▶], and then press the [DISP] button again.
- Playback now begins, and after the movie is finished, [SET] ▶ is displayed.
- To adjust the volume, press the [▲][▼] buttons during playback.



- To switch to Shooting mode from Playback mode, press the shutter button halfway.



- You can also start movie playback by touching [▶]. To adjust the volume, quickly drag up or down across the screen during playback.

Erasing Images

You can choose and erase unneeded images one by one. Be careful when erasing images, because they cannot be recovered.



1 Choose an image to erase.

- Press the [◀][▶] buttons or turn the [DISP] dial to choose an image.

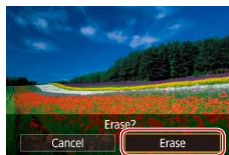

2 Erase the image.

- Press the [▲] button.
- After [Erase?] is displayed, press the [◀][▶] buttons or turn the [DISP] dial to choose [Erase], and then press the [DISP] button.
- The current image is now erased.
- To cancel erasure, press the [◀][▶] buttons or turn the [DISP] dial to choose [Cancel], and then press the [DISP] button.



- You can choose multiple images to erase at once (124).



- You can also erase the current image by touching [Erase] on the screen in step 2.
- Images can also be erased by using Touch Actions (127).

Before Use

Basic Guide

Advanced Guide

Camera Basics

Auto Mode /
Hybrid Auto Mode

Other Shooting Modes

P Mode

Tv, Av, M, and C Mode

Playback Mode

Wireless Features

Setting Menu

Accessories

Appendix

Index



Advanced Guide

Camera Basics

Other basic operations and more ways to enjoy your camera, including shooting and playback options

On/Off



Shooting Mode

- Press the power button to turn the camera on and prepare for shooting.
- To turn the camera off, press the power button again.

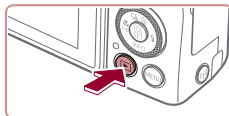

Playback Mode

- Press the [▶] button to turn the camera on and view your shots.
- To turn the camera off, press the [▶] button again.



- To switch to Playback mode from Shooting mode, press the [▶] button.
- To switch to Shooting mode from Playback mode, press the shutter button halfway (▶27).
- The lens will be retracted after about one minute once the camera is in Playback mode. You can turn the camera off when the lens is retracted by pressing the [▶] button.

Before Use

Basic Guide

Advanced Guide

Camera Basics

Auto Mode /
Hybrid Auto Mode

Other Shooting Modes

P Mode

Tv, Av, M, and C Mode

Playback Mode

Wireless Features

Setting Menu

Accessories

Appendix

Index



Power-Saving Features (Auto Power Down)

As a way to conserve battery power, the camera automatically deactivates the screen (Display Off) and then turns itself off after a specific period of inactivity.

The screen is automatically deactivated after about a minute of inactivity, and in another minute, the lens is retracted and the camera turns itself off. To activate the screen and prepare for shooting when the screen is off but the lens is still out, press the shutter button halfway (📖27).



- You can deactivate Auto Power Down and adjust the timing of Display Off, if you prefer (📖173).
- Power saving is not active while the camera is connected to other devices via Wi-Fi (📖141), or when connected to a computer (📖189).

Shutter Button

To ensure your shots are in focus, always begin by holding the shutter button halfway down, and once the subject is in focus, press the button all the way down to shoot.

In this guide, shutter button operations are described as pressing the button *halfway* or *all the way down*.

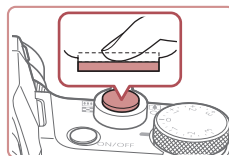

1 Press halfway. (Press lightly to focus.)

- Press the shutter button halfway. The camera beeps twice, and frames are displayed around image areas in focus.

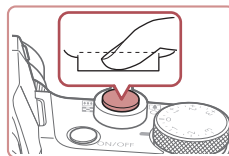

2 Press all the way down. (From the halfway position, press fully to shoot.)

- The camera shoots, as a shutter sound is played.
- Keep the camera still until the shutter sound ends.



- Images may be out of focus if you shoot without initially pressing the shutter button halfway.
- Length of shutter sound playback varies depending on the time required for the shot. It may take longer in some shooting scenes, and images will be blurry if you move the camera (or the subject moves) before the shutter sound ends.

Before Use

Basic Guide

Advanced Guide

Camera Basics

Auto Mode /
Hybrid Auto Mode

Other Shooting Modes

P Mode

Tv, Av, M, and C Mode

Playback Mode

Wireless Features

Setting Menu

Accessories

Appendix

Index



Viewfinder

▶ Still Images ▶ Movies

Shooting is easier with a viewfinder, which helps you concentrate on keeping subjects in focus.

1 Switch between using the screen and viewfinder as needed.

- Moving the viewfinder near your eye will activate its display and deactivate the camera screen.
- Moving the viewfinder away from your eye will deactivate its display and activate the camera screen.

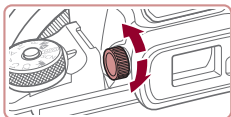

2 Adjust the diopter.

- Turn the dial to bring viewfinder images into sharp focus.



- The viewfinder display and camera screen cannot be activated at the same time.



- Although the viewfinder is produced under extremely high-precision manufacturing conditions and more than 99.99% of the pixels meet design specifications, in rare cases some pixels may be defective or may appear as red or black dots. This does not indicate camera damage or affect recorded images.
- Some aspect ratio settings (📖49) will cause black bars to be displayed on the top and bottom or left and right edges of the screen. These areas will not be recorded.
- The screen will not be activated when you move your eye away from the viewfinder if you have selected MENU (📖31) > [1] tab > [Display settings] > [Display Control] > [Manual] and then [Manual display] > [Viewfinder].
- Display of shooting information will not be adjusted when you hold the camera vertically if you have selected MENU (📖31) > [1] tab > [Shooting information display] > [VF vertical display] > [Off].
- Display switches from the viewfinder to the camera screen for some features.
- You can configure display brightness (📖173) for the viewfinder and camera screen separately.
- To reduce the shooting screen, choose MENU (📖31) > [2] tab > [VF display format] > [Display 2].

Before Use

Basic Guide

Advanced Guide

Camera Basics

Auto Mode /
Hybrid Auto Mode

Other Shooting Modes

P Mode

Tv, Av, M, and C Mode

Playback Mode

Wireless Features

Setting Menu

Accessories

Appendix

Index



Shooting Modes

Use the mode dial to access each shooting mode. As you turn it, hold down the mode dial release button in the middle of the dial.

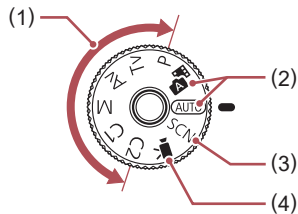

- | | |
|----------------------------------------------------------------------------------------------------------------|-------------------------------------------------------------------------------------------------------------------------------------------------------------------|
| (1) P, Tv, Av, M, C1, and C2 Modes
Take a variety of shots using your preferred settings (📖77, 📖99). | (3) Special Scene Mode
Shoot with settings designed for specific scenes, or add a variety of effects (📖56). |
| (2) Auto Mode / Hybrid Auto Mode
Fully automatic shooting, with camera-determined settings (📖23, 📖35, 📖37). | (4) Movie Mode
For shooting movies (📖72, 📖102).
You can also shoot movies when the mode dial is not set to Movie mode, simply by pressing the movie button. |

Shooting Display Options

Press the [▼] button to show or hide the grid lines and electronic level. To configure the on-screen display in greater detail, access [📷1] tab > [Shooting information display] (📖103).



- Open the screen to activate it when the camera is on. This will deactivate the viewfinder. Similarly, close the screen (facing the camera body) to deactivate it and activate the viewfinder (📖21).
- Screen brightness is automatically increased by the night view function when you are shooting under low light, making it easier to check how shots are composed. However, on-screen image brightness may not match the brightness of your shots. Note that any on-screen image distortion or jerky subject motion will not affect recorded images.
- For playback display options, see "Switching Display Modes" (📖113).

Before Use

Basic Guide

Advanced Guide

Camera Basics

Auto Mode /
Hybrid Auto Mode

Other Shooting Modes

P Mode

Tv, Av, M, and C Mode

Playback Mode

Wireless Features

Setting Menu

Accessories

Appendix

Index



Quick Set Menu

Configure commonly used functions in the **Q** (Quick Set) menu. Note that menu items and options vary depending on the shooting mode (p.209).



1 Access the **Q** menu.

- Press the **Q** button.

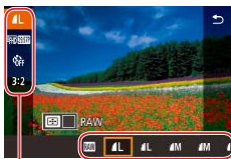

(1) (2)

2 Choose a menu item.

- Press the **▲**/**▼** buttons to choose a menu item (1).
- Available options (2) are shown at the bottom of the screen.

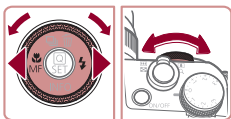

3 Choose an option.

- Press the **◀**/**▶** buttons or turn the **Q** or **Q** dial to choose an option.
- Items labeled with a **MENU** icon can be configured by pressing the **MENU** button.
- Items labeled with a **INFO** icon can be configured by pressing the **INFO** button.
- Items labeled with a **Q** icon can be configured by turning the **Q** dial.



4 Confirm your choice and exit.

- Press the **Q** button.
- The screen before you pressed the **Q** button in step 1 is displayed again, showing the option you configured.



- To undo any accidental setting changes, you can restore the camera's default settings (p.177).
- You can also exit by choosing **Q** in the menu items and pressing the **Q** button.

Using Touch-Screen Operations to Configure Settings



- Touch **Q** in the upper right of the screen to access the Quick Set menu.
- Touch a menu item and then an option to complete the setting.
- To return to the previous screen, touch the **Q** menu item, or touch the selected option again.
- You can access the screen for options labeled with a **MENU** icon by touching **MENU**.
- You can access the screen for options labeled with a **INFO** icon by touching **INFO**.

Before Use

Basic Guide

Advanced Guide

Camera Basics

Auto Mode / Hybrid Auto Mode

Other Shooting Modes

P Mode

Tv, Av, M, and C Mode

Playback Mode

Wireless Features

Setting Menu

Accessories

Appendix

Index



Menu Screen

Configure a variety of camera functions through the menu screen as follows.

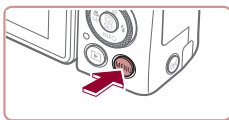

1 Access the menu screen.

- Press the [MENU] button.

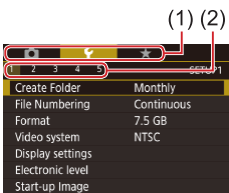

2 Choose a tab.

- Tabs represent functions (1), such as shooting ([CAMERA]), playback ([RECALL]), or settings ([MENU]), or pages within each function (2). Tabs are identified in this guide by combining the function and page, as in [CAMERA]1.
- Move the zoom lever to choose the function tab, and then press the [◀][▶] buttons or turn the [DIAL] dial to choose the page tab.

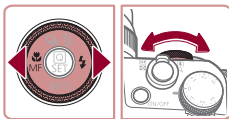
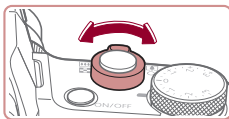

3 Choose a menu item.

- Press the [▲][▼] buttons or turn the [DIAL] dial to choose an item, and then press the [OK] button.
- For menu items with options not shown, first press the [OK] button to switch screens, and then either press the [▲][▼] buttons or turn the [DIAL] dial to select the menu item.
- To return to the previous screen, press the [MENU] button.

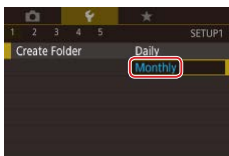

4 Choose an option.

- When options are listed vertically, press the [▲][▼] buttons or turn the [DIAL] dial to choose an option.
- When options are listed horizontally, press the [◀][▶] buttons or turn the [DIAL] dial to choose an option.



5 Confirm your choice and exit.

- Press the [OK] button to confirm your choice and return to the menu item selection screen.
- Press the [MENU] button to return to the screen displayed before you pressed the [MENU] button in step 1.



- To undo any accidental setting changes, you can restore the camera's default settings (177).
- Available menu items vary depending on the selected shooting or playback mode (212 – 222).

Before Use

Basic Guide

Advanced Guide

Camera Basics

Auto Mode /
Hybrid Auto Mode

Other Shooting Modes

P Mode

Tv, Av, M, and C Mode

Playback Mode

Wireless Features

Setting Menu

Accessories

Appendix

Index



Touch-Screen Operations

- To choose tabs, press the [MENU] button to access the menu screen, and then touch the desired function tab and page tab.
- Drag the menu items up or down to scroll them, or touch a menu item to choose it.
- Touch an option to complete the setting and return to the menu item selection screen.
- For menu items displayed with a bar to indicate the level, touch the desired position on the bar.
- To configure menu items for which options are not shown, first touch the menu item to access the setting screen. On the setting screen, either drag or touch to choose the item, and then touch to choose the option. To return to the previous screen, touch [MENU].
- You can also touch input elements (such as check boxes or text fields) to select them, and you can enter text by touching the on-screen keyboard.
- When [SET] is shown, you can touch [SET] instead of pressing the [SET] button, if you prefer.
- When [MENU] is shown, you can touch [MENU] instead of pressing the [MENU] button, if you prefer.
- When [INFO] is shown, you can touch [INFO] instead of pressing the [INFO] button, if you prefer.
- To dismiss the menu, press the [MENU] button again.

On-Screen Keyboard

Use the on-screen keyboard to enter information for Face ID (45), wireless connections (141), and so on. Note that the length and type of information you can enter varies depending on the function you are using.

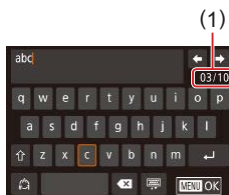

(1) Entering Characters

- Touch the characters to enter them.
- The amount of information you can enter (1) varies depending on the function you are using.

Moving the Cursor

- Touch [←][→].

Entering Line Breaks

- Touch [↵].

Switching Input Modes

- To switch to numbers or symbols, touch [123].
- Touch [⇧] to enter capital letters.
- Available input modes vary depending on the function you are using.

Deleting Characters

- Touch [⌫] to delete the previous character.
- Touching and holding [⌫] will delete five characters at a time.

Before Use

Basic Guide

Advanced Guide

Camera Basics

Auto Mode /
Hybrid Auto Mode

Other Shooting Modes

P Mode

Tv, Av, M, and C Mode

Playback Mode

Wireless Features

Setting Menu

Accessories

Appendix

Index



Confirming Input and Returning to the Previous Screen

- Press the [MENU] button.



- For some functions, [←] is not displayed and cannot be used.



- Another way to use the keyboard is by pressing the [▲][▼][◀][▶] buttons or turning the [Q] dial to select characters or icons, and then pressing the [Q] button. You can also move the cursor by turning the [G] dial. To return to the previous screen, press the [MENU] button.

Indicator Display

The indicator on the back of the camera (4) lights up or blinks depending on the camera status.

Color	Indicator Status	Camera Status
Green	Blinking	Starting up, recording/reading/transmitting images, shooting long exposures (99, 100), connected to a computer (189), connecting/transmitting via Wi-Fi, or display off (27, 173)
Orange	On	Charging via USB



- When the indicator blinks green, never turn the camera off, open the memory card/battery cover, or shake or hit the camera. Doing so may corrupt images or damage the camera or memory card.

Before Use

Basic Guide

Advanced Guide

Camera Basics

Auto Mode /
Hybrid Auto Mode

Other Shooting Modes

P Mode

Tv, Av, M, and C Mode

Playback Mode

Wireless Features

Setting Menu

Accessories

Appendix





Index



Clock

You can check the current time.



- Press and hold the  button.
- The current time appears.
- Clock display switches to vertical orientation when the camera is held vertically while the clock is displayed.
- To change the display color, press the  buttons or turn the  dial.
- Press the  button again to cancel the clock display.



- To display the clock when the camera is off, press and hold the  button, and then press the power button.

Before Use

Basic Guide

Advanced Guide

Camera Basics

Auto Mode /
Hybrid Auto Mode

Other Shooting Modes

P Mode

Tv, Av, M, and C Mode

Playback Mode

Wireless Features

Setting Menu

Accessories

Appendix

Index



Auto Mode / Hybrid Auto Mode

Convenient mode for easy shots with greater control over shooting

Shooting with Camera-Determined Settings

For fully automatic selection of the optimal settings for specific scenes, simply let the camera determine the subject and shooting conditions.

Shooting (Smart Auto)

▶ Still Images ▶ Movies

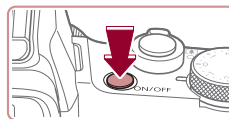

1 Turn the camera on.

- Press the power button.
- The startup screen is displayed.

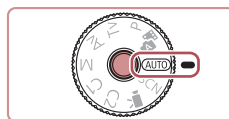

2 Enter [AUTO] mode.

- Hold down the mode dial release button and turn the mode dial to [AUTO].
- Aim the camera at the subject. The camera will make a slight clicking noise as it determines the scene.
- Icons representing the scene and image stabilization mode are displayed in the upper left of the screen (📖39, 📖41).
- Frames displayed around any detected subjects indicate that they are in focus.



Before Use

Basic Guide

Advanced Guide

Camera Basics

Auto Mode / Hybrid Auto Mode

Other Shooting Modes

P Mode

Tv, Av, M, and C Mode

Playback Mode

Wireless Features

Setting Menu

Accessories

Appendix

Index



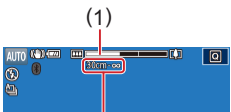

(2)

3 Zoom in or out, as needed.

- To zoom in and enlarge the subject, move the zoom lever toward [T] (telephoto), and to zoom away from the subject, move it toward [W] (wide angle). (A zoom bar (1) showing the zoom position is displayed, along with the range of focus (2).)

4 Shoot.

Shooting Still Images

1) Focus.

- Press the shutter button halfway. The camera beeps twice after focusing, and frames are displayed to indicate image areas in focus.

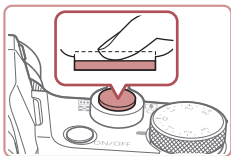

(1)

- If [Raise the flash] is displayed, lift the flash with your fingers. It will fire when shooting. If you prefer not to use the flash, push it down with your finger, into the camera.

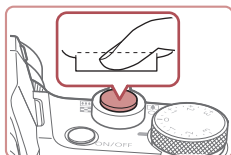
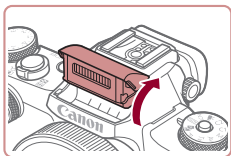

2) Shoot.

- Press the shutter button all the way down.
- As the camera shoots, a shutter sound is played, and in low-light conditions when you have raised the flash, it fires automatically.
- Keep the camera still until the shutter sound ends.
- After displaying your shot, the camera will revert to the shooting screen.

Recording Movies

1) Start recording.

- Press the movie button. The camera beeps once as recording begins, and [●Rec] is displayed with the elapsed time (1).
- Black bars are displayed on the top and bottom edges of the screen, and the subject is slightly enlarged. The black bars indicate image areas not recorded.
- Frames displayed around any detected faces indicate that they are in focus.
- Once recording begins, take your finger off the movie button.



Before Use

Basic Guide

Advanced Guide

Camera Basics

Auto Mode /
Hybrid Auto Mode

Other Shooting Modes

P Mode

Tv, Av, M, and C Mode

Playback Mode

Wireless Features

Setting Menu

Accessories

Appendix

Index



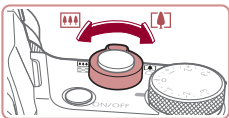

2) Adjust how the shot is composed, as needed.

- To resize the subject, repeat the operations in step 3. However, note that the sound of camera operations will be recorded. Note that movies shot at zoom factors shown in blue will look grainy.
- When you recompose shots, the focus, brightness, and colors will be automatically adjusted.



3) Stop recording.

- Press the movie button again to stop recording. The camera beeps twice as recording stops.
- Recording will stop automatically when the memory card becomes full.

Shooting in Hybrid Auto Mode

► Still Images ► Movies

You can make a short movie of the day just by shooting still images. The camera records 2 – 4-second clips of scenes before each shot, which are later combined in a digest movie.

Clips recorded in this mode may be included in Story Highlights albums (136).



1 Enter [Hybrid Auto] mode.

- Follow step 2 in “Shooting (Smart Auto)” (135) and choose [Hybrid Auto].



2 Compose the shot.

- Follow steps 3 – 4 in “Shooting (Smart Auto)” (135) to compose the shot and focus.
- For more impressive digest movies, aim the camera at subjects about four seconds before shooting still images.

3 Shoot.

- Follow step 4 in “Shooting (Smart Auto)” (135) to shoot a still image.
- The camera records both a still image and movie clip. The clip, which ends with the still image and a shutter sound, forms a single chapter in the digest movie.



- Battery life is shorter in this mode than in [AUTO] mode, because digest movies are recorded for each shot.
- A digest movie may not be recorded if you shoot a still image immediately after turning the camera on, choosing [Hybrid Auto] mode, or operating the camera in other ways.
- Sounds and vibrations from operating the camera will be recorded in digest movies.

Before Use

Basic Guide

Advanced Guide

Camera Basics

Auto Mode / Hybrid Auto Mode

Other Shooting Modes

P Mode

Tv, Av, M, and C Mode

Playback Mode

Wireless Features

Setting Menu

Accessories

Appendix

Index





- Digest movie image quality is automatically set to [HD 29.97P] for NTSC or [HD 25.00P] for PAL and cannot be changed (1172).
- Sounds are not played when you press the shutter button halfway or trigger the self-timer (1175).
- Digest movies are saved as separate movie files in the following cases even if they were recorded on the same day in [A] mode.
 - The digest movie file size reaches approximately 4 GB, or the total recording time reaches approximately 16 minutes and 40 seconds.
 - The digest movie is protected (1121).
 - Daylight saving time (121) or time zone (174) settings are changed.
 - A new folder is created (170).
- Recorded shutter sounds cannot be modified or erased.
- If you prefer to record digest movies without still images, adjust the setting in advance. Choose MENU (31) > [6] tab > [Digest Type] > [No Stills].
- Individual chapters can be edited (135).

Digest Movie Playback

Display a still image shot in [A] mode to play the digest movie created on the same day, or specify the date of the digest movie to play (114).

Still Images/Movies



- If the camera makes no operating sounds, it may have been turned on while holding down the [MENU] button. To activate sounds, press the [MENU] button, choose [Mute] on the [F3] tab, and then choose [Disable].

Still Images



- A blinking [9] icon warns that images are more likely to be blurred by camera shake. In this case, mount the camera on a tripod or take other measures to keep it still.
- If your shots are dark despite the flash firing, move closer to the subject. For details on the flash range, see “Flash” (223).
- The subject may be too close if the camera only beeps once when you press the shutter button halfway. For details on the range of focus (shooting range), see “Lens” (223).
- To reduce red-eye and to assist in focusing, the lamp may be lit when shooting in low-light conditions.
- A blinking [5] icon displayed when you attempt to shoot indicates that shooting is not possible until the flash has finished recharging. Shooting can resume as soon as the flash is ready, so either press the shutter button all the way down and wait, or release it and press it again.
- No shutter sound is played when “Sleeping” and “Sleeping Babies” icons (39) are displayed.
- Although you can shoot again before the shooting screen is displayed, your previous shot may determine the focus, brightness, and colors used.



- You can change how long images are displayed after shots (55).

Before Use

Basic Guide

Advanced Guide

Camera Basics

Auto Mode /
Hybrid Auto Mode

Other Shooting Modes

P Mode

Tv, Av, M, and C Mode

Playback Mode

Wireless Features

Setting Menu

Accessories

Appendix

Index



Movies



- Before movie recording, lower the flash with your finger. During recording, keep your fingers away from the microphone (1). Leaving the flash raised, or blocking the microphone may prevent audio from being recorded or may cause the recording to sound muffled.

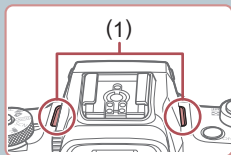

- Avoid touching camera controls other than the movie button when recording movies, because sounds made by the camera will be recorded.
- Once movie recording begins, the image display area changes and subjects are enlarged to allow for correction of significant camera shake. To shoot subjects at the same size shown before shooting, follow the steps in "Recording Movies with Subjects at the Same Size Shown before Shooting" (p.54).



- Audio is recorded in stereo.

Scene Icons

► Still Images ► Movies

In [M] and [AUTO] modes, shooting scenes determined by the camera are indicated by the icon displayed, and corresponding settings are automatically selected for optimal focusing, subject brightness, and color. Depending on the scene, continuous images may be shot (p.40).

Subject	Background				
	Normal	Backlit	Dark*1	Sunsets	Spotlights
People	*2	*3		–	
Moving People	*3	*3	–	–	–
Shadows on Face	*2	–	–	–	–
Smiling	*3	*3	–	–	–
Sleeping	*2	*3	–	–	–
Babies	*3	*3	–	–	–
Smiling Babies	*3	*3	–	–	–
Sleeping Babies	*2	*3	–	–	–
Moving Children	*3	*3	–	–	–
Other Subjects	*2	*3			
Other Moving Subjects	*3	*3	–	–	–
Other Close-Range Subjects	*2	*3	–	–	

*1 Tripod used.

*2 The background color of icons is light blue when the background is a blue sky, dark blue when the background is dark, and gray for all other backgrounds.

*3 The background color of icons is light blue when the background is a blue sky, and gray for all other backgrounds.

Before Use

Basic Guide

Advanced Guide

Camera Basics

Auto Mode / Hybrid Auto Mode

Other Shooting Modes

P Mode

Tv, Av, M, and C Mode

Playback Mode

Wireless Features

Setting Menu

Accessories

Appendix

Index



- The background color of , , , , and is dark blue, and the background color of is orange.
- For movies, only People, Other Subjects, and Other Close-Range Subjects icons are displayed.
- In mode, icons are only displayed for People, Shadows on Face, Other Subjects, and Other Close-Range Subjects.
- For self-timer shots, icons are not displayed for the following subjects: moving, smiling, or sleeping people; smiling or sleeping babies; moving children; and other moving subjects.
- Icons are not displayed for smiling or sleeping subjects and moving children in drive modes other than (p. 40, p. 44).
- Backlit icons are not displayed for moving children and smiling people when the flash is set to .
- Icons for babies (including smiling and sleeping babies) and moving children are displayed when [Face ID] is set to [On] and faces of registered babies (less than two years old) or children (2 – 12 years old) are detected (p. 45). Confirm beforehand that the date and time are correct (p. 21).



- Try shooting in mode (p. 77) if the scene icon does not match actual shooting conditions, or if it is not possible to shoot with your expected effect, color, or brightness.

Continuous Shooting Scenes

The camera shoots continuously when you take a shot while an icon for one of the following scenes is displayed. Pressing the shutter button halfway while one of the scene icons is displayed shows another icon (, , or) indicating the type of continuous shooting to be used.

Smiling (including Babies)	Consecutive images are captured, and the camera analyzes details such as facial expressions to save the image determined to be the best.
Sleeping (including Babies)	Beautiful shots of sleeping faces, created by combining consecutive shots to reduce camera shake and image noise. The AF-assist beam and the flash will not fire, and the shutter sound will not be played.
Children	So you don't miss a photo opportunity of children who move around, the camera will capture three consecutive images for each shot.



- In some scenes, expected images may not be saved, and images may not look as expected.
- Focus, image brightness, and color are determined by the first shot.



- When you want to shoot single images only, press the button, and then select (either press the buttons or turn the dial).

Before Use

Basic Guide

Advanced Guide

Camera Basics

Auto Mode /
Hybrid Auto Mode

Other Shooting Modes

P Mode

Tv, Av, M, and C Mode

Playback Mode

Wireless Features

Setting Menu

Accessories

Appendix

Index



Image Stabilization Icons

► Still Images ► Movies

Optimal image stabilization for the shooting conditions (Intelligent IS) is automatically applied, and the following icons are displayed.

	Image stabilization for still images (Normal)
	Image stabilization for still images when panning (Panning)*
	Image stabilization for angular camera shake and shift-shake in macro shots (Hybrid IS). For movies, is displayed and image stabilization is also applied.
	Image stabilization for movies, reducing strong camera shake, as when recording while walking (Dynamic)
	Image stabilization for slow camera shake, such as when recording movies at telephoto (Powered)
	No image stabilization, because the camera is mounted on a tripod or held still by other means. However, during movie recording, is displayed, and image stabilization to counteract wind or other sources of vibration is used (Tripod IS).

* Displayed when you pan, following moving subjects with the camera. When you follow subjects moving horizontally, image stabilization only counteracts vertical camera shake, and horizontal stabilization stops. Similarly, when you follow subjects moving vertically, image stabilization only counteracts horizontal camera shake.



- To cancel image stabilization, set [IS Mode] to [Off] (📖53). In this case, an IS icon is not displayed.
- is not available in mode.

On-Screen Frames

► Still Images ► Movies

In [AUTO] mode, a variety of frames are displayed once the camera detects subjects you are aiming the camera at.

- A white frame is displayed around the subject (or person's face) detected as the main subject. Frames follow moving subjects within a certain range as they are tracked to keep them in focus.
- When you are pressing the shutter button halfway and the camera detects subject movement, a blue frame is displayed, and the focus and image brightness are constantly adjusted (Servo AF).



- Try shooting in [P] mode (📖77) if no frames are displayed, if frames are not displayed around desired subjects, or if frames are displayed on the background or similar areas.
- To choose subjects to focus on, touch the desired subject on the screen. is displayed, and the camera enters Touch AF mode (📖95). Pressing the shutter button halfway will display a blue frame, and the camera will keep the subject in focus and image brightness adjusted (Servo AF).

Before Use

Basic Guide

Advanced Guide

Camera Basics

Auto Mode /
Hybrid Auto Mode

Other Shooting Modes

P Mode

Tv, Av, M, and C Mode

Playback Mode

Wireless Features

Setting Menu

Accessories

Appendix

Index



Common, Convenient Features

Zooming In Closer on Subjects (Digital Zoom)

► Still Images ► Movies

When distant subjects are too far away to enlarge using the optical zoom, use digital zoom for up to about 12x enlargement.

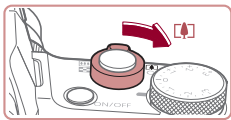

1 Move the zoom lever toward [Z].

- Hold the lever until zooming stops.
- Zooming stops at the largest zoom factor before the image becomes noticeably grainy, which is then indicated on the screen.

2 Move the zoom lever toward [Z] again.

- The camera zooms in even closer on the subject.
- (1) is the current zoom factor.

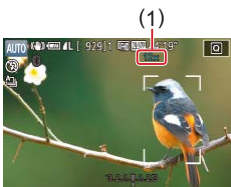

- Moving the zoom lever will display the zoom bar (which indicates the zoom position). The zoom bar is color-coded to indicate the zoom range.
 - White range: optical zoom range where the image will not appear grainy.
 - Yellow range: digital zoom range where the image is not noticeably grainy (ZoomPlus).
 - Blue range: digital zoom range where the image will appear grainy.
- Because the blue range will not be available at some recording pixel settings (30), the maximum zoom factor can be achieved by following step 1.



- To deactivate digital zoom, choose MENU (31) > [3] tab > [Digital Zoom] > [Off].

Zooming with the Continuous Ring

► Still Images ► Movies

Use the continuous ring for finer subject resizing and faster zooming than with the zoom lever.

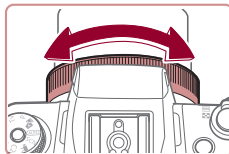

- Turn the [C] ring counterclockwise to zoom in or clockwise to zoom out.

Using the Self-Timer

► Still Images ► Movies

With the self-timer, you can include yourself in group photos or other timed shots. The camera will shoot about 10 seconds after you press the shutter button.



1 Configure the setting.

- Press the [C] button, choose [C] in the menu, and then choose [30] (30).
- Once the setting is complete, [C] is displayed.

Before Use

Basic Guide

Advanced Guide

Camera Basics

Auto Mode / Hybrid Auto Mode

Other Shooting Modes

P Mode

Tv, Av, M, and C Mode

Playback Mode

Wireless Features

Setting Menu

Accessories

Appendix

Index



2 Shoot.

- For Still Images: Press the shutter button halfway to focus on the subject, and then press it all the way down.
- For Movies: Press the movie button.
- Once you start the self-timer, the lamp will blink and the camera will play a self-timer sound.
- Two seconds before the shot, the blinking and sound will speed up. (The lamp will remain lit in case the flash fires.)
- To cancel shooting after the self-timer has been triggered, press the **[MENU]** button.
- To restore the original setting, choose **[C]** in step 1.

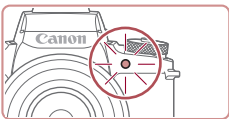

Using the Self-Timer to Avoid Camera Shake

► Still Images ► Movies

This option delays shutter release until about two seconds after you have pressed the shutter button. If the camera is unsteady while you are pressing the shutter button, it will not affect your shot.

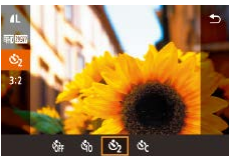

- Follow step 1 in “Using the Self-Timer” (42) and choose **[C]**.
- Once the setting is complete, **[C]** is displayed.
- Follow step 2 in “Using the Self-Timer” (42) to shoot.

Customizing the Self-Timer

► Still Images ► Movies

You can specify the delay (0 – 30 seconds) and number of shots (1 – 10).



1 Choose **[C]**.

- Following step 1 in “Using the Self-Timer” (42), choose **[C]** and press the **[MENU]** button.

2 Configure the setting.

- Press the **[▲]**/**[▼]** buttons to choose the delay time or number of shots.
- Press the **[◀]**/**[▶]** buttons or turn the **[DISP.]** dial to choose a value, and then press the **[SET.]** button twice.
- Once the setting is complete, **[C]** is displayed.
- Follow step 2 in “Using the Self-Timer” (42) to shoot.



- For movies recorded using the self-timer, recording begins after your specified delay time, but specifying the number of shots has no effect.



- When you specify multiple shots, image brightness and color tone are determined by the first shot. More time is required between shots when the flash fires or when you have specified to take many shots. Shooting will stop automatically when the memory card becomes full.
- When a delay longer than two seconds is specified, two seconds before the shot, the lamp blinking and self-timer sound will speed up. (The lamp will remain lit in case the flash fires.)

Before Use

Basic Guide

Advanced Guide

Camera Basics

Auto Mode /
Hybrid Auto Mode

Other Shooting Modes

P Mode

Tv, Av, M, and C Mode

Playback Mode

Wireless Features

Setting Menu

Accessories

Appendix

Index



Shooting by Touching the Screen (Touch Shutter)

▶ Still Images ▶ Movies

With this option, instead of pressing the shutter button, you can simply touch the screen and release your finger to shoot. The camera will focus on subjects and adjust image brightness automatically.

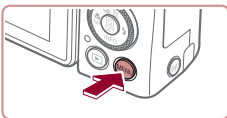

1 Enable the touch-shutter function.

- Press the [MENU] button and choose [CAMERA] tab > [Touch Shutter] > [Touch Shutter] > [Enable] (p.31).

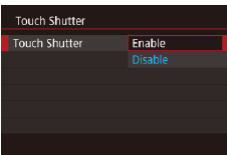

2 Shoot.

- Touch the subject on the screen to take the picture.
- The camera shoots, as a shutter sound is played.
- To cancel touch shutter, choose [Disable] in step 1.



- Even while the shot is displayed, you can prepare for the next shot by touching [REVIEW].

Continuous Shooting

▶ Still Images ▶ Movies

In [AUTO] mode, hold the shutter button all the way down to shoot continuously.

For details on the continuous shooting speed, see “Shooting” (p.224).

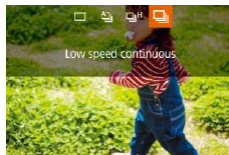

1 Configure the setting.

- Press the [▲] button, choose [CAMERA] or [MOVIE] (either press the [◀][▶] buttons or turn the [DISP.] dial), and then press the [MENU] button.
- Once the setting is complete, [CAMERA] or [MOVIE] is displayed.

2 Shoot.

- Hold the shutter button all the way down to shoot continuously.



- During continuous shooting, the focus, exposure, and colors are locked at the position/level determined when you pressed the shutter button halfway.
- Cannot be used with the self-timer (p.42).
- Shooting may stop momentarily or continuous shooting may slow down depending on shooting conditions, camera settings, and the zoom position.
- As more shots are taken, shooting may slow down.
- Shooting may slow down if the flash fires.
- With Touch Shutter (p.44), the camera shoots continuously while you touch the screen. Focus and exposure during continuous shooting remain constant, after they are determined for the first shot.

Before Use

Basic Guide

Advanced Guide

Camera Basics

Auto Mode / Hybrid Auto Mode

Other Shooting Modes

P Mode

Tv, Av, M, and C Mode

Playback Mode

Wireless Features

Setting Menu

Accessories

Appendix

Index



Shooting with Face ID

If you register a person ahead of time, the camera will detect that person's face, and prioritize focus, brightness, and color for that person when shooting. In [AUTO] mode, the camera can detect babies and children based on registered birthdays and optimize settings for them when shooting.

This function also enables you to find shots you have taken that include registered people (📖116).

Registering people in advance also makes it easier to add them when creating Story Highlights albums (📖136).

Personal Information

- The camera stores face information (face images) registered using Face ID, as well as entered personal information (names and birthdays). Additionally, when registered people are detected, their names will be recorded in still images. For this reason, after using Face ID functions, be careful when giving the camera or images to others, or when posting images online where many people can view them.
- When disposing of a camera or transferring it to another person after using Face ID, be sure to erase all information (registered faces, names, and birthdays) from the camera (📖49).

Registering Face ID Information

You can register information (face info, names, and birthdays) for up to 12 people to use with Face ID.

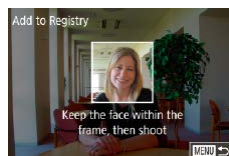
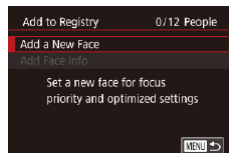
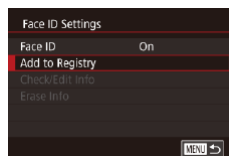
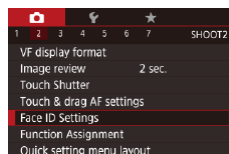

1 Access the setting screen.

- Press the [MENU] button, choose [Face ID Settings] on the [📷2] tab, and then press the [ⓘ] button (📖31).

- Press the [▲][▼] buttons or turn the [🔍] dial to choose [Add to Registry], and then press the [ⓘ] button.

- Press the [▲][▼] buttons or turn the [🔍] dial to choose [Add a New Face], and then press the [ⓘ] button.

2 Register face information.

- Aim the camera so that the face of the person you want to register is inside the gray frame at the center of the screen.
- A white frame on the person's face indicates that the face is recognized. Make sure a white frame is displayed on the face, and then shoot.
- If the face is not recognized, you cannot register face information.

Before Use

Basic Guide

Advanced Guide

Camera Basics

Auto Mode / Hybrid Auto Mode

Other Shooting Modes

P Mode

Tv, Av, M, and C Mode

Playback Mode

Wireless Features

Setting Menu

Accessories

Appendix

Index



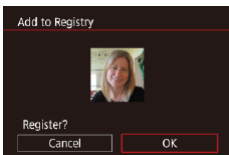

- After [Register?] is displayed, press the [◀][▶] buttons or turn the [DISP] dial to choose [OK], and then press the [SET] button.
- The [Edit Profile] screen is displayed.

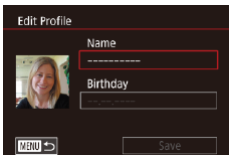

3 Register the person's name and birthday.

- Press the [SET] button to access the keyboard, and then enter the name (📖32).

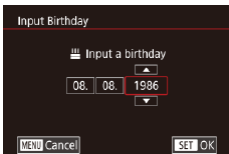

- To register a birthday, on the [Edit Profile] screen, choose [Birthday] (either press the [▲][▼] buttons or turn the [DISP] dial), and then press the [SET] button.
- Press the [◀][▶] buttons to choose an option.
- Press the [▲][▼] buttons or turn the [DISP] dial to specify the date.
- When finished, press the [SET] button.

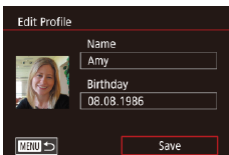

4 Save the settings.

- Press the [▲][▼] buttons or turn the [DISP] dial to choose [Save], and then press the [SET] button.
- After a message is displayed, press the [◀][▶] buttons or turn the [DISP] dial to choose [Yes], and then press the [SET] button.

5 Continue registering face information.

- To register up to 4 more points of face information (expressions or angles), repeat step 2.
- Registered faces are more easily recognized if you add a variety of face information. In addition to a head-on angle, add a slight side angle, a shot when smiling, and shots inside and outside.



- The flash will not fire when following step 2.
- If you do not register a birthday in step 3, Babies or Children icons (📖39) will not be displayed in [AUTO] mode.



- You can overwrite registered face info, and add face info later if you have not filled all 5 face info slots (📖45).

Shooting

If you register a person ahead of time, the camera will prioritize that person as the main subject, and optimize focus, brightness, and color for that person when shooting.



- When you point the camera toward people, the name of the person detected as the main subject is displayed.
- Shoot.
- Displayed names will be recorded in still images. The names of detected people (maximum total of 5) will be recorded, even if the names are not displayed.

Before Use

Basic Guide

Advanced Guide

Camera Basics

Auto Mode / Hybrid Auto Mode

Other Shooting Modes

P Mode

Tv, Av, M, and C Mode

Playback Mode

Wireless Features

Setting Menu

Accessories

Appendix

Index





- People other than those registered may be mistakenly detected as the registered person if they share similar facial features.



- Registered people may not be correctly detected if the captured image or scene differs drastically from the registered face information.
- If a registered face is not detected, or not easily detected, overwrite registered information with new face info. Registering face info right before shooting will allow for easier detection of registered faces.
- If a person is mistakenly detected as another person and you continue shooting, you can edit or erase the name recorded in the image during playback (📖119).
- Because faces of babies and children change as they grow, you should update their face info regularly (📖48).
- Names will still be recorded in images even if you clear the [Shooting Info] check box in “Customizing the Information Displayed” (📖104) so that the names are not displayed.
- If you don't want names to be recorded in images, choose [Face ID Settings] on the [📷2] tab, choose [Face ID], and then choose [Off].
- You can check names recorded in images in the playback screen (simple information display) (📖113).
- Names recorded in continuous shooting (📖44) continue to be recorded in the same position as the first shot, even if subjects move.

Checking and Editing Registered Information

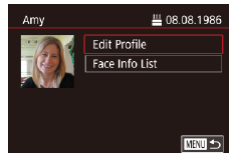
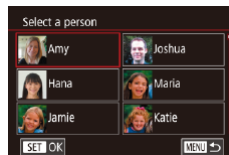
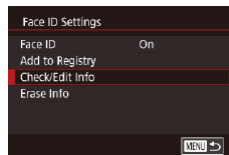

1 Access the [Check/Edit Info] screen.

- Following step 1 in “Registering Face ID Information” (📖45), choose [Check/Edit Info].

2 Choose a person to check or edit their information.

- Press the [▲][▼][◀][▶] buttons to choose the person whose information you want to check or edit, and then press the [👤] button.

3 Check or edit the information as needed.

- To check a name or birthday, choose [Edit Profile] (either press the [▲][▼] buttons or turn the [👤] dial), and then press the [👤] button. On the screen displayed, you can edit the name or birthday as described in step 3 of “Registering Face ID Information” (📖45).
- To check face information, choose [Face Info List] (either press the [▲][▼] buttons or turn the [👤] dial), and then press the [👤] button. To erase face information, press the [👤] button on the screen displayed, choose face information to erase by pressing the [▲][▼][◀][▶] buttons or turning the [👤] dial, and then press the [👤] button. After [Erase?] is displayed, choose [OK] (either press the [◀][▶] buttons or turn the [👤] dial), and then press the [👤] button.

Before Use

Basic Guide

Advanced Guide

Camera Basics

Auto Mode / Hybrid Auto Mode

Other Shooting Modes

P Mode

Tv, Av, M, and C Mode

Playback Mode

Wireless Features

Setting Menu

Accessories

Appendix

Index





- Even if you change names in [Edit Profile], the names recorded in previously shot images will remain the same.

Overwriting and Adding Face Information

You can overwrite existing face information with new face info. You should update face information regularly, especially with babies and children, because their faces change as they grow.

As long as all 5 face info slots have not been filled, you can also add face information.

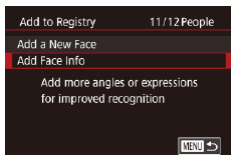

1 Access the [Add Face Info] screen.

- Following step 1 in “Registering Face ID Information” (45), choose [Add Face Info].

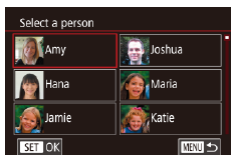

2 Choose a person to overwrite their face info.

- Press the [▲][▼][◀][▶] buttons to choose the name of the person whose face info you want to overwrite, and then press the [SET] button.
- If five items of face info have already been registered, a message will be displayed. Choose [OK] (either press the [◀][▶] buttons or turn the [DIAL] dial), and then press the [SET] button.
- If less than five items of face info are registered, go to step 4 to add face information.

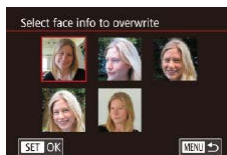

3 Choose the face info to overwrite.

- Press the [▲][▼][◀][▶] buttons or turn the [DIAL] dial to choose the face info to overwrite, and then press the [SET] button.

4 Register face information.

- Follow step 2 in “Registering Face ID Information” (45) to shoot, and then register the new face information.
- Registered faces are more easily recognized if you add a variety of face information. In addition to a head-on angle, add a slight side angle, a shot when smiling, and shots inside and outside.



- You cannot add face information if all 5 information slots are filled. Follow the steps above to overwrite face information.
- You can follow the above steps to register new face info when there is at least one slot open; however, you cannot overwrite any face information. Instead of overwriting face info, first erase unwanted existing info (49), and then register new face information (45) as needed.

Before Use

Basic Guide

Advanced Guide

Camera Basics

Auto Mode / Hybrid Auto Mode

Other Shooting Modes

P Mode

Tv, Av, M, and C Mode

Playback Mode

Wireless Features

Setting Menu

Accessories

Appendix

Index



Erasing Registered Information

You can erase information (face info, names, and birthdays) registered to Face ID. However, names recorded in previously shot images will not be erased.

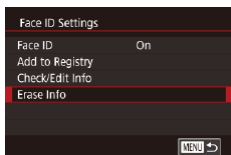

1 Access the [Erase Info] screen.

- Follow step 1 in “Registering Face ID Information” (📖45) and choose [Erase Info].

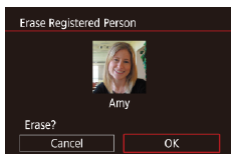

2 Choose a person to erase their information.

- Press the [▲][▼][◀][▶] buttons to choose the name of the person to erase, and then press the [⏏] button.
- After [Erase?] is displayed, press the [◀][▶] buttons or turn the [🔘] dial to choose [OK], and then press the [⏏] button.



- If you erase a registered person's info, you will not be able to display their name (📖115), overwrite their info (📖119), or search for images that include them (📖116).



- You can also erase names in image information (📖119).

Image Customization Features

Changing the Aspect Ratio

▶ Still Images ▶ Movies

Change the image aspect ratio (ratio of width to height) as follows.



- Press the [🔘] button, choose [3:2] in the menu, and choose the desired option (📖30).
- Once the setting is complete, the screen aspect ratio will be updated.
- To restore the original setting, repeat this process but choose [3:2].

16:9	Used for display on widescreen HDTVs or similar display devices.
3:2	Native aspect ratio of the camera screen. Same aspect ratio as 35mm film, used for printing images at 5 x 7-inch or postcard sizes.
4:3	Used for display on standard-definition televisions or similar display devices. Also used for printing images at 3.5 x 5-inch or A-series sizes.
1:1	Square aspect ratio.



- Not available in [📷] mode.
- You can also configure this setting by choosing MENU (📖31) > [📷1] tab > [Still Image Aspect Ratio].

Before Use

Basic Guide

Advanced Guide

Camera Basics

Auto Mode / Hybrid Auto Mode

Other Shooting Modes

P Mode

Tv, Av, M, and C Mode

Playback Mode

Wireless Features

Setting Menu

Accessories

Appendix

Index



Changing Image Quality

► Still Images ► Movies

Choose from 7 combinations of size (number of pixels) and compression (image quality). Also specify whether to capture images in RAW format (book 50).



- Press the button, choose in the menu, and choose the desired option (book 30).
- The option you configured is now displayed.
- To restore the original setting, repeat this process but choose .



- and indicate different levels of image quality depending on the extent of compression. At the same size (number of pixels), offers higher image quality. Although images have slightly lower image quality, more fit on a memory card. Note that [S2]-size images are of quality.
- Not available in mode.
- You can also change the image quality by accessing MENU (book 31) > tab > [Image quality].

When deciding the number of pixels based on print size, use the following table as a guide for images with a 3:2 aspect ratio.

L	A2 (16.5 x 23.4 in.)
M	A3 (11.7 x 16.5 in.)
S1	A4 (8.3 x 11.7 in.)
S2	3.5 x 5 in., 5 x 7 in., Postcard

Capturing in RAW Format

The camera can capture images in JPEG and RAW format.

JPEG Images	Processed in the camera for optimal image quality and compressed to reduce file size. However, the compression process is irreversible, and images cannot be restored to their original, unprocessed state. Image processing may also cause some loss of image quality.
RAW Images	“Raw” (unprocessed) data, recorded with essentially no loss of image quality from the camera’s image processing. The data cannot be used in this state for viewing on a computer or printing. You must first process it on this camera (book 132) or use the Digital Photo Professional application (book 189) to convert images to ordinary JPEG or TIFF files. Images can be adjusted with minimal loss of image quality during processing.



- Press the button, and then choose in the menu (book 30).
- To capture in RAW format only, choose the option.
- To capture images in both JPEG and RAW format simultaneously, choose the JPEG image quality, and then press the button. A mark is displayed next to [RAW]. To undo this setting, follow the same steps and remove the mark next to [RAW].



- When transferring RAW images (or RAW and JPEG images recorded together) to a computer, always use the dedicated software (book 189).
- Digital zoom (book 42) is not available when capturing images in RAW format.

Before Use

Basic Guide

Advanced Guide

Camera Basics

Auto Mode / Hybrid Auto Mode

Other Shooting Modes

P Mode

Tv, Av, M, and C Mode

Playback Mode

Wireless Features

Setting Menu

Accessories

Appendix

Index





- The file extension for JPEG images is .JPG, and the extension for RAW images is .CR2.
- You can also configure this setting by accessing MENU (31) > [CAMERA 1] tab > [Image quality].

Using the Menu

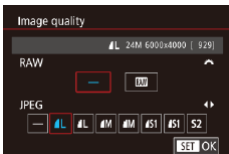

- Press the [MENU] button, choose [Image quality] on the [CAMERA 1] tab, and then press the [OK] button (31).
- To capture in RAW format at the same time, turn the [MODE] dial and choose [RAW] under [RAW]. Note that only JPEG images are captured when [-] is selected.
- Press the [LEFT] [RIGHT] buttons or turn the [MODE] dial to choose [JPEG], and then choose the image size and quality. Note that only RAW images are captured when [-] is selected.
- When finished, press the [OK] button to return to the menu screen.



- [RAW] and [JPEG] cannot both be set to [-].

Changing Movie Image Quality

▶ Still Images ▶ Movies

Adjust movie image quality (image size and frame rate). The frame rate indicates how many frames are recorded per second, which is determined automatically based on the NTSC or PAL setting (172).



- Press the [MODE] button, choose the movie quality menu item, and then choose the desired option (30).
- The option you configured is now displayed.

For NTSC Video

Image Quality	Number of Recording Pixels	Frame Rate	Details
FHD 59.94P	1920 x 1080	59.94 fps	For shooting in full HD. FHD 59.94P enables movies with smoother motion.
FHD 29.97P	1920 x 1080	29.97 fps	
FHD 23.98P	1920 x 1080	23.98 fps	
HD 29.97P	1280 x 720	29.97 fps	For shooting in HD.
VGA 29.97P	640 x 480	29.97 fps	For shooting in standard definition.

Before Use

Basic Guide

Advanced Guide

Camera Basics

Auto Mode / Hybrid Auto Mode

Other Shooting Modes

P Mode

Tv, Av, M, and C Mode

Playback Mode

Wireless Features

Setting Menu

Accessories

Appendix

Index



For PAL Video

Image Quality	Number of Recording Pixels	Frame Rate	Details
[FHD 50.00P]	1920 x 1080	50.00 fps	For shooting in full HD.
[FHD 25.00P]	1920 x 1080	25.00 fps	
[HD 25.00P]	1280 x 720	25.00 fps	For shooting in HD.
[VGA 25.00P]	640 x 480	25.00 fps	For shooting in standard definition.



- Black bars (displayed on the left and right in [VGA 29.97P] and [VGA 25.00P] modes and on the top and bottom in [FHD 59.94P], [FHD 29.97P], [FHD 23.98P], [HD 29.97P], [FHD 50.00P], [FHD 25.00P], and [HD 25.00P] modes) indicate image areas not recorded.
- You can also configure this setting by choosing MENU (31) > [7] tab > [Movie rec. size].

Helpful Shooting Features

Using the Dual Axis Electronic Level

▶ Still Images ▶ Movies

An electronic level can be displayed as a guideline to ensure the camera is level from front to back and left to right.



(1) (2)

1 Display the electronic level.

- Press the [▼] button several times to display the electronic level.

2 Straighten the camera.

- (1) indicates the front-back orientation and (2) the left-right orientation.
- If the camera is tilted, move it so that the red line changes to green.



- If the electronic level is not displayed in step 1, press the [MENU] button and check the setting in [7] tab > [Shooting information display] (103).
- The electronic level is not displayed during movie recording.
- If you hold the camera vertically, the orientation of the electronic level will be updated automatically to match the camera orientation.
- Calibrate the electronic level if it seems ineffective in helping you level the camera (172).
- Not available in [A] mode.

Before Use

Basic Guide

Advanced Guide

Camera Basics

Auto Mode / Hybrid Auto Mode

Other Shooting Modes

P Mode

Tv, Av, M, and C Mode

Playback Mode

Wireless Features

Setting Menu

Accessories

Appendix

Index



Deactivating Auto Level

▶ Still Images ▶ Movies

Auto leveling keeps movies straight. To cancel this feature, choose [Disable].



- Press the [MENU] button, choose [Auto level] on the [CAMERA] tab, and then press the [OK] button (p.31).
- Choose [Disable], and press the [OK] button again (p.31).



- Once recording begins, the display area narrows, and subjects are enlarged (p.54).

Changing the IS Mode Settings

Deactivating Image Stabilization

▶ Still Images ▶ Movies

When the camera is held still (as when shooting from a tripod), you should set image stabilization to [Off] to deactivate it.

1 Access the setting screen.

- Press the [MENU] button, choose [IS Settings] on the [CAMERA] tab, and then press the [OK] button (p.31).

2 Configure the setting.

- Press the [▲][▼] buttons or turn the [DISP.] dial to choose [IS Mode], press the [OK] button, and then press the [▲][▼] buttons or turn the [DISP.] dial to choose the desired option (p.31).

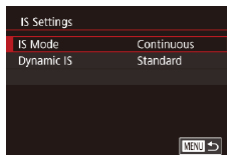

Continuous	Optimal image stabilization for the shooting conditions is automatically applied (Intelligent IS) (p.41).
Off	Deactivates image stabilization.

Before Use

Basic Guide

Advanced Guide

Camera Basics

Auto Mode /
Hybrid Auto Mode

Other Shooting Modes

P Mode

Tv, Av, M, and C Mode

Playback Mode

Wireless Features

Setting Menu

Accessories

Appendix

Index



Recording Movies with Subjects at the Same Size Shown before Shooting

▶ Still Images ▶ Movies

Normally, once movie recording begins, the image display area changes and subjects are enlarged to allow for image straightening and correction of significant camera shake.

To record movies with subjects at the same size shown before shooting, you can reduce image stabilization and cancel Auto level.

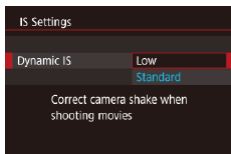

- Set [Auto level] to [Disable] as described in “Deactivating Auto Level” (53).
- Follow step 1 in “Deactivating Image Stabilization” (53) to access the [IS Settings] screen.
- Choose [Dynamic IS], and then choose [Low] (31).



- You can also set [IS Mode] to [Off], so that subjects are recorded at the same size shown before shooting.
- [Dynamic IS] is not available when [IS Mode] is set to [Off] (53).
- Only [Standard] is available when the movie quality is [AVC 29.97P] (NTSC) or [AVC 25.00P] (PAL).

Customizing Camera Operation

Customize shooting functions on the [CAM] tab of the menu screen as follows.

For instructions on menu functions, see “Menu Screen” (31).

Preventing the AF-Assist Beam from Firing

▶ Still Images ▶ Movies

The lamp lights up to help you focus when you press the shutter button halfway in low-light conditions. This lamp can be deactivated.

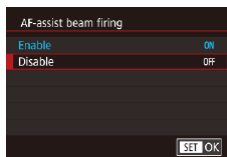

- Press the [MENU] button, choose [AF-assist beam firing] on the [CAM] tab, and then choose [Disable].
- To restore the original setting, repeat this process but choose [Enable].

Before Use

Basic Guide

Advanced Guide

Camera Basics

Auto Mode / Hybrid Auto Mode

Other Shooting Modes

P Mode

Tv, Av, M, and C Mode

Playback Mode

Wireless Features

Setting Menu

Accessories

Appendix

Index



Preventing the Red-Eye Reduction Lamp from Lighting Up

▶ Still Images ▶ Movies

A red-eye reduction lamp lights up to reduce red-eye when the flash is used in low-light shots. This lamp can be deactivated.

1 Access the [Flash Control] screen.

- Press the [MENU] button, choose [Flash Control] on the [CAMERA] tab, and then press the [OK] button.

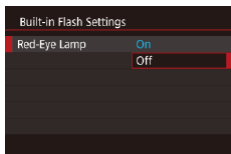

2 Configure the setting.

- Choose [Red-Eye Lamp], and then choose [Off].
- To restore the original setting, repeat this process but choose [On].

Changing the Image Display Style after Shots

▶ Still Images ▶ Movies

You can change how long images are displayed after shots.

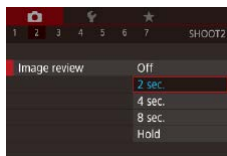

- Press the [MENU] button, choose [Image review] on the [CAMERA] tab, and then choose the desired option.
- To restore the original setting, repeat this process but choose [2 sec.].

2 sec.,	Displays images for the specified time. Even while the shot is displayed, you can take another shot by pressing the shutter button halfway again.
4 sec.,	
8 sec.	
Hold	Displays images until you press the shutter button halfway.
Off	No image display after shots.



- By pressing the [▼] button while an image is displayed after shooting, you can switch the display information.

Before Use

Basic Guide

Advanced Guide

Camera Basics

Auto Mode /
Hybrid Auto Mode

Other Shooting Modes

P Mode

Tv, Av, M, and C Mode

Playback Mode

Wireless Features

Setting Menu

Accessories

Appendix

Index



Other Shooting Modes

Shoot more effectively in various scenes, and take shots enhanced with unique image effects or captured using special functions



Specific Scenes

Choose a mode matching the shooting scene, and the camera will automatically configure the settings for optimal shots.



1 Enter [SCN] mode.

- Hold down the mode dial release button and turn the mode dial to [SCN].

2 Choose a shooting mode.

- Press the [MENU] button, choose [SCN] in the menu, and then choose a shooting mode (p.30).

3 Shoot.



- You can also choose a shooting mode by touching [SCN] in the upper left after you set the mode dial to [SCN].



Shooting Portraits (Portrait)

▶ Still Images ▶ Movies

- Take shots of people with a softening effect.

Before Use

Basic Guide

Advanced Guide

Camera Basics

Auto Mode /
Hybrid Auto Mode

Other Shooting Modes

P Mode

Tv, Av, M, and C Mode

Playback Mode

Wireless Features

Setting Menu

Accessories

Appendix

Index





Shooting Evening Scenes without Using a Tripod (Handheld Night Scene)

▶ Still Images ▶ Movies

- Beautiful shots of evening scenes or portraits with evening scenery in the background, without the need to hold the camera very still (as with a tripod).
- A single image is created by combining consecutive shots, reducing camera shake and image noise.



Shooting Underwater (Underwater)

▶ Still Images ▶ Movies

- Natural-colored shots of sea life and underwater scenery, when you use an optional waterproof case (📖182).
- This mode can correct white balance and match the effect of using a commercially available color-compensating filter (📖58).









Shooting Fireworks (Fireworks)



▶ Still Images ▶ Movies

- Vivid shots of fireworks.



- Subjects appear larger in  mode compared to other modes.
- In  and  modes, shots may look grainy because the ISO speed (📖80) is increased to suit the shooting conditions.
- Because the camera will shoot continuously in  mode, hold it steady while shooting.
- In  mode, excessive motion blur or certain shooting conditions may prevent you from obtaining the desired results.
- In  mode, mount the camera on a tripod or take other measures to keep it still and prevent camera shake. Additionally, you should set [IS Mode] to [Off] when using a tripod or other means to secure the camera (📖53).



- When you use a tripod for evening scenes, shooting in [AUTO] mode instead of  mode will give better results (📖35).
- In  mode, although no frames are displayed when you press the shutter button halfway, optimal focus is still determined.
- You can also choose the shooting mode by accessing MENU (📖31) >  1 tab > [Rec. Mode].

Before Use

Basic Guide

Advanced Guide

Camera Basics

Auto Mode /
Hybrid Auto Mode

Other Shooting Modes

P Mode

Tv, Av, M, and C Mode

Playback Mode

Wireless Features

Setting Menu

Accessories

Appendix

Index



Using Functions for Underwater Shots

Shooting with an Underwater Focus Range

▶ Still Images ▶ Movies

If focusing is difficult in $[M]$ mode (📖56) with a focus range of $[A]$, using a focus range designed for underwater shooting can ensure optimal underwater shots.

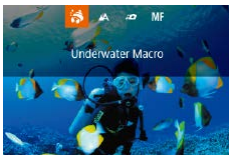

1 Configure the setting.

- Follow steps 1 – 2 in “Specific Scenes” (📖56) and choose $[M]$.
- Press the $[L]$ button, choose the desired focus range (either press the $[L]$ buttons or turn the $[D]$ dial), and then press the $[M]$ button.

2 Shoot.

Focus Range	Description
Underwater Macro	Take close-ups of sea life, using the digital zoom for even closer shots.
Quick	Avoid missing unexpected underwater shooting opportunities when shooting subjects some distance away. Especially effective for moving subjects.
Manual focus	Focus on subjects manually (📖89).

Refer to “Lens” (📖223) for details on the range of each focus range.



- In $[M]$ mode, optical zoom is set to maximum wide angle.
- In $[M]$ mode, use of digital zoom may cause images to appear grainy at some recording pixel settings (📖50).
- In $[Q]$ mode, subjects at close range may not be in focus. In this case, try setting the focus range to $[A]$.



- You can also configure this setting by pressing the $[L]$ button, touching the desired focus range, and then touching it again.

Correcting White Balance

▶ Still Images ▶ Movies

White balance can be manually corrected in $[M]$ mode (📖56). This adjustment can match the effect of using a commercially available color-compensating filter.

1 Choose $[M]$.

- Follow steps 1 – 2 in “Specific Scenes” (📖56) and choose $[M]$.

2 Choose white balance.

- Press the $[WB]$ button, and then choose $[WB]$ in the menu.

3 Adjust the setting.

- Turn the $[WB]$ dial to adjust the correction level for B and A, and then press the $[M]$ button.
- Once the setting is complete, $[WB]$ is displayed.

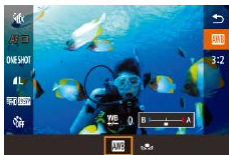

- B represents blue and A, amber.
- White balance can also be manually corrected by recording custom white balance data (📖83) before following the preceding steps.

Before Use

Basic Guide

Advanced Guide

Camera Basics

Auto Mode / Hybrid Auto Mode

Other Shooting Modes

P Mode

Tv, Av, M, and C Mode

Playback Mode

Wireless Features

Setting Menu

Accessories

Appendix

Index



Applying Special Effects

Add a variety of effects to images when shooting.

Shooting Yourself under Optimal Settings (Self Portrait)

For self-portraits, customizable image processing includes skin smoothing as well as brightness and background adjustment to make yourself stand out.

1 Choose [📷].

- Follow steps 1 – 2 in “Specific Scenes” (📖56) and choose [📷].

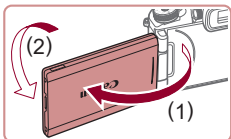

2 Open the screen.

- Open the screen as shown.



3 Configure the setting.

- On the screen, touch the icon of the setting to configure.

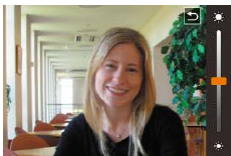

- Choose the desired option.
- To return to the previous screen, touch [↶].

4 Shoot.

Item	Details
	Choose from [AUTO] or one of five levels of background defocusing.
	Choose from five levels of brightness.
	Choose from five levels of skin smoothing. Skin smoothing is optimized for the main subject's face.
	To use touch shutter, choose [📷].



- Areas other than people's skin may be modified, depending on the shooting conditions.
- Try taking some test shots first to make sure you obtain the desired results.



- In [📷] flash mode, background defocusing is set to [AUTO] and cannot be changed.
- In [📷] mode, the time left before shooting is shown on the top of the screen when you activate the self-timer by selecting [⌚], or by selecting [🕒] and setting the time to 3 seconds or more.

Before Use

Basic Guide

Advanced Guide

Camera Basics

Auto Mode / Hybrid Auto Mode

Other Shooting Modes

P Mode

Tv, Av, M, and C Mode

Playback Mode

Wireless Features

Setting Menu

Accessories

Appendix

Index



Making Skin Look Smoother (Smooth Skin)

▶ Still Images ▶ Movies

You can enhance skin tone to make it look smoother.

1 Choose [⦿].

- Follow steps 1 – 2 in “Specific Scenes” (p.56) and choose [⦿].



2 Choose an effect level.

- Press the [▼] button.
- Press the [◀][▶] buttons or turn the [⦿] dial to choose an effect level, and then press the [⦿] button.
- A preview is shown of how your shot will look with the effect applied.

3 Shoot.



- Areas other than people's skin may be modified, depending on the shooting conditions.
- Try taking some test shots first to make sure you obtain the desired results.

Shooting Panoramas (Panoramic Shot)

▶ Still Images ▶ Movies

Create a panorama combining shots captured continuously as you move the camera one direction while holding the shutter button all the way down.

1 Enter [📷] mode.

- Follow steps 1 – 2 in “Specific Scenes” (p.56) and choose [📷].



2 Choose a shooting direction.

- Press the [📷] button and choose the direction you will shoot.
- An arrow is displayed showing the direction to move the camera.

3 Focus.

- Press the shutter button halfway to focus on the subject, and continue holding the button halfway down.

4 Shoot.

- Holding the shutter button all the way down, move the camera at a constant speed in the direction of the arrow.
- The area displayed clearly (1) is captured.
- A shooting progress indicator is displayed (2).
- Shooting stops when you release the shutter button, or when the progress indicator is completely blue.

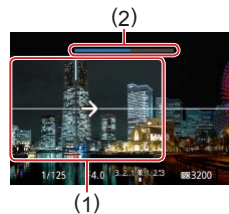

Before Use

Basic Guide

Advanced Guide

Camera Basics

Auto Mode / Hybrid Auto Mode

Other Shooting Modes

P Mode

Tv, Av, M, and C Mode

Playback Mode

Wireless Features

Setting Menu

Accessories

Appendix

Index





- In some scenes, expected images may not be saved, and images may not look as expected.
- Shooting may stop midway if you move the camera too slowly or quickly. However, the panorama created up to that point will still be saved.
- Images created from shots in [] mode are large. Use a computer or other device to reduce panorama images if you will print them by inserting a memory card in a Canon printer. If panoramas are not compatible with certain software or Web services, try resizing them on a computer.



- The following subjects and scenes may not be stitched correctly.
 - Subjects that are moving
 - Subjects that are nearby
 - Scenes where the contrast varies greatly
 - Scenes with long stretches of the same color or pattern, such as the sea or sky



- You can also set the shooting direction by touching [].

Conveying a Sense of Speed by Blurring the Background (Panning)

▶ Still Images ▶ Movies

By panning, you can blur the background to convey a sense of speed. The camera will detect and correct subject blurring, so the subject will remain relatively clear and sharp.

1 Choose [].

- Follow steps 1 – 2 in “Specific Scenes” ([] 56) and choose [].



2 Shoot.

- Before shooting, press the shutter button halfway as you move the camera so that it follows the subject.
- Keep the moving subject in the frame displayed, and press the shutter button all the way down.
- Even after you have pressed the shutter button fully, continue moving the camera to follow the subject.



- Try taking some test shots first to make sure you obtain the desired results.



- To adjust the effect level, turn the [] dial.
- You can move the frame by dragging it or touching the screen.
- For best results, hold the camera securely in both hands, with your elbows close to your body, and rotate your whole body to follow the subject.
- This feature is more effective for subjects moving horizontally, such as cars or trains.

Before Use

Basic Guide

Advanced Guide

Camera Basics

Auto Mode /
Hybrid Auto Mode

Other Shooting Modes

P Mode

Tv, Av, M, and C Mode

Playback Mode

Wireless Features

Setting Menu

Accessories

Appendix

Index



Shooting in Monochrome (Grainy B/W)

▶ Still Images ▶ Movies

Take monochrome pictures with a gritty, rough feeling.

1 Choose [A].

- Follow steps 1 – 2 in “Specific Scenes” (p.56) and choose [A].

2 Choose an effect level.

- Turn the [Sun] dial to choose an effect level.
- A preview is shown of how your shot will look with the effect applied.

3 Shoot.



Shooting with a Soft Focus Effect

▶ Still Images ▶ Movies

This function allows you to shoot images as if a soft focus filter were attached to the camera. You can adjust the effect level as desired.

1 Choose [A].

- Follow steps 1 – 2 in “Specific Scenes” (p.56) and choose [A].

2 Choose an effect level.

- Turn the [Sun] dial to choose an effect level.
- A preview is shown of how your shot will look with the effect applied.

3 Shoot.



- Try taking some test shots first to make sure you obtain the desired results.

Before Use

Basic Guide

Advanced Guide

Camera Basics

Auto Mode /
Hybrid Auto Mode

Other Shooting Modes

P Mode

Tv, Av, M, and C Mode

Playback Mode

Wireless Features

Setting Menu

Accessories

Appendix

Index



Shooting with a Fish-Eye Lens Effect (Fish-Eye Effect)

▶ Still Images ▶ Movies

Shoot with the distorting effect of a fish-eye lens.

1 Choose [📷].

- Follow steps 1 – 2 in “Specific Scenes” (📖56) and choose [📷].



2 Choose an effect level.

- Turn the [🌞] dial to choose an effect level.
- A preview is shown of how your shot will look with the effect applied.

3 Shoot.



- Try taking some test shots first to make sure you obtain the desired results.

Shots Resembling Oil Paintings (Art Bold Effect)

▶ Still Images ▶ Movies

Make subjects look more substantial, like subjects in oil paintings.

1 Choose [🎨].

- Follow steps 1 – 2 in “Specific Scenes” (📖56) and choose [🎨].

2 Choose an effect level.

- Turn the [🌞] dial to choose an effect level.
- A preview is shown of how your shot will look with the effect applied.



3 Shoot.

Before Use

Basic Guide

Advanced Guide

Camera Basics

Auto Mode /
Hybrid Auto Mode

Other Shooting Modes

P Mode

Tv, Av, M, and C Mode

Playback Mode

Wireless Features

Setting Menu

Accessories

Appendix

Index



Shots Resembling Watercolors (Water Painting Effect)

▶ Still Images ▶ Movies

Soften colors, for photos resembling watercolor paintings.

1 Choose [📷].

- Follow steps 1 – 2 in “Specific Scenes” (📖56) and choose [📷].



2 Choose an effect level.

- Turn the [🔆] dial to choose an effect level.
- A preview is shown of how your shot will look with the effect applied.

3 Shoot.

Shooting with a Toy Camera Effect (Toy Camera Effect)

▶ Still Images ▶ Movies

This effect makes images resemble shots from a toy camera, with vignetting (darker, blurred image corners) and modified color overall.

1 Choose [📷].

- Follow steps 1 – 2 in “Specific Scenes” (📖56) and choose [📷].



2 Choose a color tone.

- Turn the [🔆] dial to choose a color tone.
- A preview is shown of how your shot will look with the effect applied.

3 Shoot.

Standard	Shots resemble toy camera images.
Warm	Images have a warmer tone than with [Standard].
Cool	Images have a cooler tone than with [Standard].



- Try taking some test shots first to make sure you obtain the desired results.

Before Use

Basic Guide

Advanced Guide

Camera Basics

Auto Mode /
Hybrid Auto Mode

Other Shooting Modes

P Mode

Tv, Av, M, and C Mode

Playback Mode

Wireless Features

Setting Menu

Accessories

Appendix

Index



Shots Resembling Miniature Models (Miniature Effect)

► Still Images ► Movies

Creates the effect of a miniature model, by blurring image areas above and below your selected area.

You can also make movies that look like scenes in miniature models by choosing the playback speed before the movie is recorded. People and objects in the scene will move quickly during playback. Note that sound is not recorded.

1 Choose [📏].

- Follow steps 1 – 2 in “Specific Scenes” (📖56) and choose [📏].
- A white frame is displayed, indicating the image area that will not be blurred.



2 Choose the area to keep in focus.

- Press the [▼] button.
- Move the zoom lever to resize the frame, and turn the [🌀] dial to move it.



3 For movies, choose the movie playback speed.

- Turn the [🌀] dial to choose the speed.

4 Return to the shooting screen and shoot.

- Press the [📷] button to return to the shooting screen, and then shoot.

Playback Speed and Estimated Playback Time (for One-Minute Clips)

Speed	Playback Time
5x	Approx. 12 sec.
10x	Approx. 6 sec.
20x	Approx. 3 sec.

Movies are played back at 30 fps.



- The zoom is not available when shooting movies. Be sure to set the zoom before shooting.
- Try taking some test shots first to make sure you obtain the desired results.



- To switch the orientation of the frame to vertical, press the [◀][▶] buttons in step 2. To return the frame to horizontal orientation, press the [▲][▼] buttons.
- To move the frame when it is in horizontal orientation, press the [▲][▼] buttons, and to move the frame when it is in vertical orientation, press the [◀][▶] buttons.
- Holding the camera vertically will change the orientation of the frame.
- Movie image quality is [EVA] at an aspect ratio of [4:3] and [EHD] at an aspect ratio of [16:9] (📖49). These quality settings cannot be changed.



- You can also move the frame by touching or dragging across the screen.

Before Use

Basic Guide

Advanced Guide

Camera Basics

Auto Mode /
Hybrid Auto Mode

Other Shooting Modes

P Mode

Tv, Av, M, and C Mode

Playback Mode

Wireless Features

Setting Menu

Accessories

Appendix

Index



Shooting High-Contrast Scenes (High Dynamic Range)

► Still Images ► Movies

Three consecutive images are captured at different brightness levels each time you shoot, and the camera combines image areas with optimal brightness to create a single image. This mode can reduce the washed-out highlights and loss of detail in shadows that tend to occur in high-contrast shots.

1 Choose [HDR].

- Follow steps 1 – 2 in “Specific Scenes” (56) and choose [HDR].

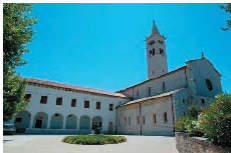

2 Shoot.

- Hold the camera steady as you shoot. When you press the shutter button all the way down, the camera will take three shots and combine them.



- Excessive motion blur or certain shooting conditions may prevent you from obtaining the desired results.
- Subjects are displayed larger than in other modes.



- If excessive camera shake interferes with shooting, mount the camera on a tripod or take other measures to keep it still. Additionally, you should set [IS Mode] to [Off] when using a tripod or other means to secure the camera (53).
- Any subject movement will cause images to look blurry.
- There will be a delay before you can shoot again, as the camera processes and combines the images.
- [**N** / **LOW**] may be displayed when you press the shutter button halfway in bright conditions, indicating automatic adjustment for optimal image brightness.

Adding Artistic Effects



- Follow steps 1 – 2 in “Specific Scenes” (56) and choose [HDR].
- Turn the [] dial to choose an effect.
- A preview is shown of how your shot will look with the effect applied.

Natural	Images are natural and organic.
Art Standard	Images resemble paintings, with subdued contrast.
Art Vivid	Images resemble vivid illustrations.
Art Bold	Images resemble oil paintings, with bold edges.
Art Embossed	Images resemble old photos, with bold edges and dark ambiance.

Before Use

Basic Guide

Advanced Guide

Camera Basics

Auto Mode /
Hybrid Auto Mode

Other Shooting Modes

P Mode

Tv, Av, M, and C Mode

Playback Mode

Wireless Features

Setting Menu

Accessories

Appendix

Index



Special Modes for Other Purposes

Shooting Starry Skies (Star)

Shooting Night Scenes under Starry Skies (Star Nightscape)

▶ Still Images ▶ Movies

Capture impressive shots of starry skies above night scenes. Starlight in the image is automatically enhanced, making starry skies look beautiful.



1 Choose [Star].

- Follow steps 1 – 2 in “Specific Scenes” (📖56) and choose [Star], and then press the [▲] button.
- Press the [◀][▶] buttons or turn the [DIAL] dial to choose [Star], and then press the [DIAL] button.
- Zoom is set to maximum wide angle and cannot be adjusted.

2 Secure the camera.

- Mount the camera on a tripod or take other measures to keep it still and prevent camera shake.

3 Shoot.



- There will be a delay before you can shoot again, as the camera processes the images.



- For easier viewing, try choosing MENU > [F2] tab > [Night Display] > [On] (📖172) before shooting.
- To make stars brighter, choose MENU (📖31) > [CAMERA] tab > [Star Emphasis] > [Sharp]. To emphasize the bright stars in a starry sky, set [Star Emphasis] to [Soft]. This setting can produce eye-catching shots by enlarging bright stars while de-emphasizing dimmer stars. To disable starlight processing, select [Off].
- Try switching to manual focus mode (📖89) to more accurately specify the focal position before shooting.

Shooting Star Trails (Star Trails)

▶ Still Images ▶ Movies

Streaks created by the movement of stars through the sky are recorded in a single image. After determining the shutter speed and number of shots, the camera shoots continuously. A shooting session can last up to about two hours. Check the battery level in advance.



1 Choose [Star Trails].

- Follow steps 1 – 2 in “Specific Scenes” (📖56) and choose [Star Trails], and then press the [▲] button.
- Press the [◀][▶] buttons or turn the [DIAL] dial to choose [Star Trails], and then press the [DIAL] button.
- Zoom is set to maximum wide angle and cannot be adjusted.

2 Specify the duration of the shooting session.

- Turn the [DIAL] dial to choose the shooting duration.

Before Use

Basic Guide

Advanced Guide

Camera Basics

Auto Mode /
Hybrid Auto Mode

Other Shooting Modes

P Mode

Tv, Av, M, and C Mode

Playback Mode

Wireless Features

Setting Menu

Accessories

Appendix

Index



3 Secure the camera.

- Mount the camera on a tripod or take other measures to keep it still.



4 Shoot.

- Press the shutter button all the way down. [Busy] is displayed briefly, and then shooting begins.
- Do not disturb the camera while shooting.
- To cancel shooting, press the shutter button all the way down again. Note that cancellation may take up to about 30 seconds.



- If the camera runs out of battery power, shooting stops and a composite image created from the images up to that point is saved.
- There will be a delay before you can shoot again, as the camera processes the images.



- For easier viewing, try choosing MENU > [Y2] tab > [Night Display] > [On] (172) before shooting.
- Try switching to manual focus mode (89) to more accurately specify the focal position before shooting.

Recording Movies of Star Movement (Star Time-Lapse Movie)

▶ Still Images ▶ Movies

By recording a time-lapse movie that combines images shot at a specified interval, you can create movies with fast-moving stars. You can adjust the shooting interval and recording duration as needed. Note that each session takes a long time, and requires many shots. Check the battery level and memory card space in advance.



1 Choose [].

- Follow steps 1 – 2 in “Specific Scenes” (56) and choose [], and then press the [▲] button.
- Press the [◀][▶] buttons or turn the [] dial to choose [], and then press the [] button.
- Zoom is set to maximum wide angle and cannot be adjusted.

2 Configure movie settings.

- Press the [▶] button.
- Press the [▲][▼] buttons or turn the [] dial to choose an item, and then choose the desired option.

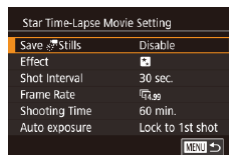

3 Secure the camera.

- Mount the camera on a tripod or take other measures to keep it still.

Before Use

Basic Guide

Advanced Guide

Camera Basics

Auto Mode /
Hybrid Auto Mode

Other Shooting Modes

P Mode

Tv, Av, M, and C Mode

Playback Mode

Wireless Features

Setting Menu

Accessories

Appendix

Index



4 Check the brightness.

- Press the shutter button all the way down to shoot a single still image.
- Switch to Playback mode (📖 111) and check image brightness.
- To adjust brightness, turn the exposure compensation dial and change the exposure level on the shooting screen. Check brightness again by taking another shot.



5 Shoot.

- Press the movie button. Recording begins, and the indicator on the back of the camera blinks.
- Do not disturb the camera while shooting.
- To cancel shooting, press the movie button again. Note that cancellation may take up to about 30 seconds.
- The camera operates in Eco mode (📖 173) while shooting.

Item	Options	Details
Save 🌟 Stills	Enable, Disable	You can choose to save each shot collected before the movie is created. Note that when [Enable] is selected, [Effect] is not available.
Effect	🌟 🌠 🌈 🌩 🌪	Choose movie effects, such as star trails.
Shot Interval	15 sec., 30 sec., 1 min.	Choose the interval between each shot.
Frame Rate	📺 4.99, 📺 9.97 (NTSC) 📺 2.50, 📺 5.00 (PAL)	Choose the movie frame rate.
Shooting Time	60 min., 90 min., Unlimited	Choose the length of the recording session. To record until the battery runs out, choose [Unlimited].
Auto exposure	Lock to 1st shot, For each shot	Choose whether exposure is determined by the first shot or adjusted for each shot.

Estimated playback time based on shooting interval and frame rate (for a one-hour session)

Interval between Shots	Frame Rate		Playback Time
	NTSC	PAL	
15 sec.	📺 4.99	📺 2.50	16 sec.
15 sec.	📺 9.97	📺 5.00	8 sec.
30 sec.	📺 4.99	📺 2.50	8 sec.
30 sec.	📺 9.97	📺 5.00	4 sec.
1 min.	📺 4.99	📺 2.50	4 sec.
1 min.	📺 9.97	📺 5.00	2 sec.

Before Use

Basic Guide

Advanced Guide

Camera Basics

Auto Mode /
Hybrid Auto Mode

Other Shooting Modes

P Mode

Tv, Av, M, and C Mode

Playback Mode

Wireless Features

Setting Menu

Accessories

Appendix

Index





- There will be a delay before you can shoot again, as the camera processes the images.
- If the camera runs out of battery power or memory card space, shooting stops and a movie created from the images up to that point is saved.
- A shooting interval of [1 min.] is not available with these effects: .



- Sound is not recorded.
- For easier viewing, try choosing MENU > [Y2] tab > [Night Display] > [On] (172) before shooting.
- You can also access the screen in step 2 by choosing MENU (31) > [6] tab > [Star Time-Lapse Movie Setting].
- Images saved with [Save Stills] set to [Enable] are managed as a single group, and during playback, only the first image is displayed. To indicate that the image is part of a group, [SET] is displayed in the upper left of the screen. If you erase a grouped image (123), all images in the group are also erased. Be careful when erasing images.
- Grouped images can be played back individually (118) and ungrouped (118).
- Protecting (121) a grouped image will protect all images in the group.
- Grouped images can be viewed individually when played back using Image Search (116). In this case, images are temporarily ungrouped.
- The following actions are not available for grouped images: magnifying (120), tagging as favorites (126), editing (128), printing (191), setting up individual image printing (195), or adding to a photobook (197). To do these things, either view grouped images individually (118) or cancel grouping (118) first.
- Try switching to manual focus mode (89) to more accurately specify the focal position before shooting.

Adjusting Colors

► Still Images ► Movies

Colors can be manually adjusted in mode.

1 Choose a shooting mode.

- Choose (67), (67), or (68).

2 Choose color adjustment.

- Press the button, and then choose in the menu (30).

3 Adjust the setting.

- Turn the dial or press the [◀|▶] buttons to adjust the correction level for B and A, and then press the button.
- Once the setting is complete, is displayed.



- B represents blue and A, amber.
- Advanced settings can be accessed by pressing the button when the screen in step 2 is displayed (84).



- You can also choose the correction level by touching or dragging the bar in step 2.

Before Use

Basic Guide

Advanced Guide

Camera Basics

Auto Mode / Hybrid Auto Mode

Other Shooting Modes

P Mode

Tv, Av, M, and C Mode

Playback Mode

Wireless Features

Setting Menu

Accessories

Appendix

Index



Adjusting the Focus

▶ Still Images ▶ Movies

Automatically adjust the focus to suit starry skies.

1 Choose a shooting mode.

- Choose [P] (67), [A] (67), or [S+] (68).

2 Secure the camera.

- Mount the camera on a tripod or take other measures to keep it still.

3 Frame the stars to capture.

- Press the [X] button.
- Tilt the camera so that the stars to capture are inside the frame displayed.



4 Adjust the focus.

- Press the [L] button. [Adjusting star focus] is displayed, and adjustment begins.
- Adjustment may take about 15 seconds. Do not move the camera until [Adjustment completed] is displayed.
- Press the [L] button.

5 Shoot (67, 67, 68).



- The focus may not be adjusted under the following conditions. In this case, try again from step 3.
 - There is a bright light source
 - Airplanes or other light sources or clouds crossed the sky



- If adjustment fails, focus returns to the original position.

Before Use

Basic Guide

Advanced Guide

Camera Basics

Auto Mode /
Hybrid Auto Mode

Other Shooting Modes

P Mode

Tv, Av, M, and C Mode

Playback Mode

Wireless Features

Setting Menu

Accessories

Appendix

Index



Recording Various Movies

Recording Movies in [M] Mode

▶ Still Images ▶ Movies



1 Enter [M] mode.

- Hold down the mode dial release button and turn the mode dial to [M].
- Press the [Q] button, choose [M] in the menu, and then choose [M] (📖30).
- Black bars are displayed on the top and bottom edges of the screen, and the subject is slightly enlarged. The black bars indicate image areas not recorded.

2 Configure the settings to suit the movie (📖207).

3 Shoot.

- Press the movie button.
- To stop movie recording, press the movie button again.



- You can also choose the shooting mode by accessing MENU (📖31) > [CAM] tab > [Rec. Mode].



- Focus can be adjusted during recording by touching [AF] and pressing the [▲][▼] buttons while [MF] is displayed.

Locking or Changing Image Brightness

▶ Still Images ▶ Movies

You can lock the exposure before or during recording or adjust it in 1/3-stop increments within a range of -3 to +3 stops.



1 Lock the exposure.

- Touch [X] to lock the exposure.
- To unlock the exposure, touch [X] again.

2 Adjust the exposure.

- Turn the exposure compensation dial.

3 Shoot (📖72).

Before Use

Basic Guide

Advanced Guide

Camera Basics

Auto Mode /
Hybrid Auto Mode

Other Shooting Modes

P Mode

Tv, Av, M, and C Mode

Playback Mode

Wireless Features

Setting Menu

Accessories

Appendix

Index



Disabling Auto Slow Shutter

▶ Still Images ▶ Movies

Auto slow shutter can be disabled if movement in movies is rough. However, under low light, movies may look dark.

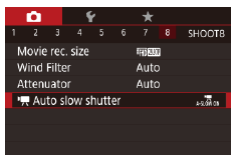

- Press the [MENU] button, choose [Auto slow shutter] on the [CAMERA] tab, and then choose [A-SLOW OFF] (31).
- To restore the original setting, repeat this process but choose [A-SLOW ON].



- Auto slow shutter is only available for [FHD 59.94P] and [FHD 50.00P] movies.

Correcting Severe Camera Shake

▶ Still Images ▶ Movies

Counteract severe camera shake, such as when recording while moving. The portion of images displayed changes, and subjects are enlarged more than for [Standard].

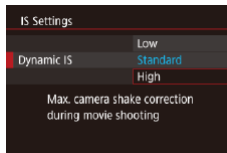

- Follow the steps in “Recording Movies with Subjects at the Same Size Shown before Shooting” (54) to choose [High].



- [Dynamic IS] is not available when [IS Mode] is set to [Off].
- Only [Standard] is available when the movie quality is [VGA 29.97P] (NTSC) or [VGA 25.00P] (PAL).

Before Use

Basic Guide

Advanced Guide

Camera Basics

Auto Mode / Hybrid Auto Mode

Other Shooting Modes

P Mode

Tv, Av, M, and C Mode

Playback Mode

Wireless Features

Setting Menu

Accessories

Appendix

Index



Sound Settings

▶ Still Images ▶ Movies

Deactivating the Wind Filter

Noise caused by strong wind can be reduced. However, the recording may sound unnatural when this option is used when there is no wind. In this case, you can deactivate the wind filter.

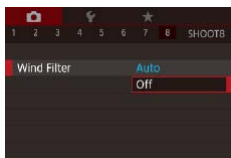

- Press the [MENU] button, choose [Wind Filter] on the [8] tab, and then press the [OK] button (📖31).
- Choose [Off] (📖31).

Using the Attenuator

Set to [Auto] to reduce audio distortion by automatically activating and deactivating the attenuator to suit shooting conditions. The attenuator can also be set to [On] or [Off] manually.

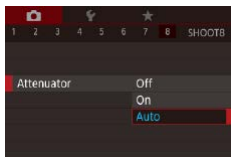

- Press the [MENU] button, choose [Attenuator] on the [8] tab, and then press the [OK] button (📖31).
- Choose an option as desired (📖31).

Recording Short Clips

▶ Still Images ▶ Movies

Apply playback effects to brief clips of a few seconds, such as fast motion, slow motion, or replay. Clips recorded in this mode may be included in Story Highlights albums (📖136).

1 Enter [L] mode.

- Hold down the mode dial release button and turn the mode dial to [L].
- Press the [OK] button, choose [L] in the menu, and then choose [L] (📖30).
- Black bars displayed on the top and bottom edges of the screen indicate image areas not recorded.



2 Specify the shooting time and playback effect.

- Press the [▶] button.
- Turn the [DIAL] dial to set the shooting time (4 – 6 sec.), and turn the [DIAL] dial to set the playback effect (📖74).

3 Shoot (📖72).

- A bar showing the elapsed time is displayed.

Playback Effects

2x	Playback in fast motion
1x	Playback at normal speed
1/2x	Playback in slow motion
	Normal playback with the last two seconds rewind and played again in slow motion

Before Use

Basic Guide

Advanced Guide

Camera Basics

Auto Mode / Hybrid Auto Mode

Other Shooting Modes

P Mode

Tv, Av, M, and C Mode

Playback Mode

Wireless Features

Setting Menu

Accessories

Appendix

Index





- Sound is not recorded in these clips.
- The movie quality is [HD 29.97P] (for NTSC) or [HD 25.00P] (for PAL) (1080i51, 1080i52) and cannot be changed.
- During [L] recording, a mark indicating the last two seconds is added to the bar showing the elapsed time.

Recording Time-Lapse Movies (Time-Lapse Movie)

▶ Still Images ▶ Movies

Time-lapse movies combine images that are shot automatically at a specified interval. Any gradual changes of the subject (such as changes in a landscape) are played back in fast motion. You can adjust the shooting interval and number of shots.

1 Choose [L].

- Hold down the mode dial release button and turn the mode dial to [L].
- Press the [OK] button, choose [L] in the menu, and then choose [L] (1/30).
- Black bars displayed on the top and bottom edges of the screen indicate image areas not recorded.

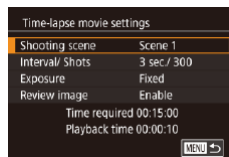

2 Configure movie settings.

- Press the [R] button.
- Press the [▲][▼] buttons or turn the [DIAL] dial to choose an item. Choose the desired option, and then press the [MENU] button.

3 Secure the camera.

- Mount the camera on a tripod or take other measures to keep it still.

4 Shoot.

- To start shooting, press the movie button.
- Do not disturb the camera while shooting.
- To cancel shooting, press the movie button again.
- The camera operates in Eco mode (173) while shooting.

Before Use

Basic Guide

Advanced Guide

Camera Basics

Auto Mode / Hybrid Auto Mode

Other Shooting Modes

P Mode

Tv, Av, M, and C Mode

Playback Mode

Wireless Features

Setting Menu

Accessories

Appendix

Index



Item	Details
Shooting scene	Choose from three types of scenes.
Interval/ Shots	Choose the shooting interval (in seconds) and total number of shots.
Exposure	Choose whether exposure is determined by the first shot or adjusted for each shot.
Review image	Display the previous shot for up to 2 seconds.
Time required	Length of the recording session. Varies depending on the shooting interval and number of shots. <ul style="list-style-type: none"> - Scene 1: Up to 1 hour - Scene 2 or 3: Up to 2 hours
Playback time	Playback time of the movie created from captured still images.



- Fast-moving subjects may look distorted in movies.



- Sound is not recorded.
- Focus remains constant during shooting, after it is determined for the first shot.
- The movie quality is [FHD] and cannot be changed.
- The time-lapse movie frame rate is automatically set to [FHD 29.97P] for NTSC or [FHD 25.00P] for PAL and cannot be changed (172).
- You can also configure this setting by choosing MENU (31) > [7] tab > [Time-lapse movie settings].

Before Use

Basic Guide

Advanced Guide

Camera Basics

Auto Mode /
Hybrid Auto Mode

Other Shooting Modes

P Mode

Tv, Av, M, and C Mode

Playback Mode

Wireless Features

Setting Menu

Accessories

Appendix

Index



P Mode

More discerning shots, in your preferred shooting style



- Instructions in this chapter apply to the camera with the mode dial set to **[P]** mode.
- **[P]**: Program AE; AE: Auto Exposure
- Before using a function introduced in this chapter in modes other than **[P]**, make sure the function is available in that mode (📖207).

Shooting in Program AE ([P] Mode)

▶ Still Images ▶ Movies

You can customize many function settings to suit your preferred shooting style.



1 Enter [P] mode.

- Hold down the mode dial release button and turn the mode dial to **[P]**.

2 Customize the settings as desired (📖78 – 📖98), and then shoot.



- If the optimum exposure cannot be obtained when you press the shutter button halfway, the shutter speed and aperture value are displayed in orange. In this case, try adjusting the ISO speed (📖80) or activating the flash (if subjects are dark, 📖96), which may enable optimum exposure.
- Movies can be recorded in **[P]** mode as well, by pressing the movie button. However, some **[Q]** menu (📖30) and MENU (📖31) settings may be automatically adjusted for movie recording.

Before Use

Basic Guide

Advanced Guide

Camera Basics

Auto Mode /
Hybrid Auto Mode

Other Shooting Modes

P Mode

Tv, Av, M, and C Mode

Playback Mode

Wireless Features

Setting Menu

Accessories

Appendix

Index



Image Brightness (Exposure)

Adjusting Image Brightness (Exposure Compensation)

▶ Still Images ▶ Movies

The standard exposure set by the camera can be adjusted in 1/3-stop increments, in a range of -3 to +3.



- As you watch the screen, turn the exposure compensation dial to adjust brightness.

Deactivating Exposure Simulation

Images are displayed at a brightness simulating the actual brightness as captured. For this reason, screen brightness is also adjusted in response to changes in exposure compensation. This feature can be disabled to keep the screen at a brightness convenient for shooting, unaffected by exposure compensation.

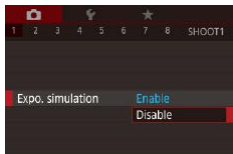

- Press the [MENU] button, choose [Expo. simulation] on the [CAMERA] tab, and then choose [Disable] (31).

Locking Image Brightness / Exposure (AE Lock)

▶ Still Images ▶ Movies

Before shooting, you can lock the exposure, or you can specify focus and exposure separately.



1 Lock the exposure.

- Aim the camera at the subject to shoot with the exposure locked, and then press the [AE-L/AF-ON] button.
- [AE-L/AF-ON] is displayed, and the exposure is locked.
- To unlock AE, press the [AE-L/AF-ON] button again. [AE-L/AF-ON] is no longer displayed.

2 Compose the shot and shoot.



- AE: Auto Exposure
- After the exposure is locked, you can adjust the combination of shutter speed and aperture value by turning the [AE-L/AF-ON] dial (Program Shift).

Before Use

Basic Guide

Advanced Guide

Camera Basics

Auto Mode / Hybrid Auto Mode

Other Shooting Modes

P Mode

Tv, Av, M, and C Mode

Playback Mode

Wireless Features

Setting Menu

Accessories

Appendix

Index



Changing the Metering Method

▶ Still Images ▶ Movies

Adjust the metering method (how brightness is measured) to suit shooting conditions as follows.



- Press the **[METERING]** button, choose **[Spot]** in the menu, and choose the desired option (📖30).
- The option you configured is now displayed.

Evaluative metering	For typical shooting conditions, including backlit shots. Automatically adjusts exposure to match the shooting conditions.
Spot metering	Metering restricted to within the [] (Spot AE Point frame). You can also link the Spot AE Point frame to the AF frame (📖79).
Center-weighted average	Determines the average brightness of light across the entire image area, calculated by treating brightness in the central area as more important.

Linking the Spot AE Point Frame to the AF Frame

▶ Still Images ▶ Movies

1 Set the metering method to **[Spot]**.

- Follow the steps in “Changing the Metering Method” (📖79) to choose **[Spot]**.

2 Configure the setting.

- Press the **[MENU]** button, choose [Spot AE Point] on the **[CAMERA]** tab, and then choose [AF Point] (📖31).
- The Spot AE Point frame will now be linked to the movement of the AF frame (📖91).

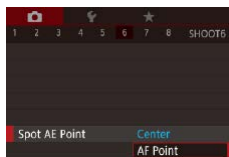

- Not available when [AF method] is set to **[+Tracking]** (📖92).

Before Use

Basic Guide

Advanced Guide

Camera Basics

Auto Mode /
Hybrid Auto Mode

Other Shooting Modes

P Mode

Tv, Av, M, and C Mode

Playback Mode

Wireless Features

Setting Menu

Accessories

Appendix

Index



Changing the ISO Speed

▶ Still Images ▶ Movies

Set the ISO speed to [AUTO] for automatic adjustment to suit the shooting mode and conditions. Otherwise, set a higher ISO speed for higher sensitivity, or a lower value for lower sensitivity.



- Press the **[ISO]** button, choose **[ISO]** in the menu, and choose the desired option (📖30).
- The option you configured is now displayed.



- To view the automatically determined ISO speed when you have set the ISO speed to [AUTO], press the shutter button halfway.
- Although choosing a lower ISO speed may reduce image graininess, there may be a greater risk of subject and camera shake in some shooting conditions.
- The faster shutter speed used at higher ISO speeds reduces subject and camera shake and increases the flash range. However, shots may look grainy.
- You can also set the ISO speed by accessing MENU (📖31) > **[5]** tab > [ISO speed] > [ISO Speed].

Adjusting ISO Auto Settings

▶ Still Images ▶ Movies

When the camera is set to [AUTO], maximum ISO speed can be specified in a range of [400] – [25600], and sensitivity can be specified in a range of three levels.

1 Access the setting screen.

- Press the **[MENU]** button, choose [ISO speed] on the **[5]** tab, and then press the **[ISO]** button (📖31).
- Choose [ISO Auto Settings] and press the **[ISO]** button.

2 Configure the setting.

- Choose a menu item to configure, and then choose the desired option (📖31).

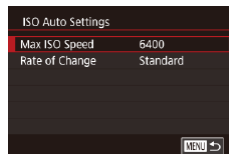

Changing the Noise Reduction Level (High ISO speed NR)

You can choose from 3 levels of noise reduction: [Standard], [High], [Low]. This function is especially effective when shooting at high ISO speeds.

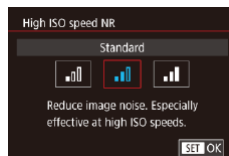

- Press the **[MENU]** button, choose [High ISO speed NR] on the **[6]** tab, and then choose the desired option (📖31).

Before Use

Basic Guide

Advanced Guide

Camera Basics

Auto Mode / Hybrid Auto Mode

Other Shooting Modes

P Mode

Tv, Av, M, and C Mode

Playback Mode

Wireless Features

Setting Menu

Accessories

Appendix

Index



Auto Exposure Bracketing (AEB Shooting)

▶ Still Images ▶ Movies

Three consecutive images are captured at different exposure levels (standard exposure, underexposure, and then overexposure) each time you shoot. You can adjust the amount of underexposure and overexposure (relative to standard exposure) from -2 to +2 stops in 1/3-stop increments.

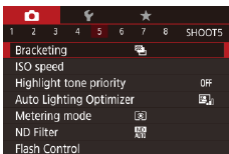

1 Choose [AEB].

- Press the [MENU] button, choose [Bracketing] on the [CAMERA] tab, and then choose [AEB] (31).

2 Configure the setting.

- Press the [OK] button, and then adjust the setting by pressing the [LEFT] [RIGHT] buttons or turning the [DIAL] dial.



- AEB shooting is only available in [P] mode (96).
- Continuous shooting (44) is not available in this mode.



- If exposure compensation is already in use (78), the value specified for that function is treated as the standard exposure level for this function.
- You can also access the setting screen of step 2 by pressing the [MENU] button when the exposure compensation screen (78) is displayed.
- Three shots are taken, regardless of any quantity specified in [C] (43).

Adjusting Auto ND Filter Settings

For optimal brightness in the scenes you shoot, Auto ND filter reduces light intensity to 1/8 the actual level, by an amount equivalent to three stops. Choosing [ON] enables you to reduce the shutter speed and aperture value.

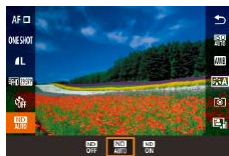

- Press the [MENU] button, choose [ND] in the menu, and choose the desired option (30).
- The option you configured is now displayed.



- When selecting [ON], mount the camera on a tripod or take other measures to keep it still and prevent camera shake. Additionally, you should set [IS Mode] to [Off] when using a tripod or other means to secure the camera (53).



- ND: Neutral Density

Before Use

Basic Guide

Advanced Guide

Camera Basics

Auto Mode / Hybrid Auto Mode

Other Shooting Modes

P Mode

Tv, Av, M, and C Mode

Playback Mode

Wireless Features

Setting Menu

Accessories

Appendix

Index



Auto Correction of Brightness and Contrast (Auto Lighting Optimizer)

▶ Still Images ▶ Movies

Correct brightness and contrast automatically to avoid images that are too dark or lack contrast.

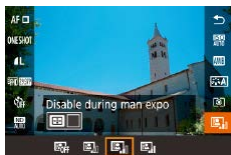

- Press the button, choose in the menu, and choose the desired option (30).



- This feature may increase noise under some shooting conditions.
- When the effect of Auto Lighting Optimizer is too strong and images become too bright, set it to [Low] or [Disable].
- Images may still be bright or the effect of exposure compensation may be weak under a setting other than [Disable] if you use a darker setting for exposure compensation or flash exposure compensation. For shots at your specified brightness, set this feature to [Disable].



- You can also configure this setting by choosing MENU (31) > tab > [Auto Lighting Optimizer].
- To keep the Auto Lighting Optimizer disabled in and modes, press the button on the Auto Lighting Optimizer setting screen to add a mark to [Disable during man expo].

Shooting Bright Subjects (Highlight Tone Priority)

▶ Still Images ▶ Movies

Improve gradation in bright image areas to avoid loss of detail in subject highlights.

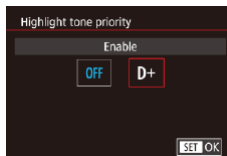

- Press the button, choose [Highlight tone priority] on the tab, and then choose [D+] (31).



- With [D+], ISO speeds lower than [160] are not available. Auto Lighting Optimizer is also disabled, in this case.

Before Use

Basic Guide

Advanced Guide

Camera Basics

Auto Mode /
Hybrid Auto Mode

Other Shooting Modes

P Mode

Tv, Av, M, and C Mode

Playback Mode

Wireless Features

Setting Menu

Accessories

Appendix

Index



Image Colors

Capturing Natural Colors (White Balance)

► Still Images ► Movies

By adjusting white balance (WB), you can make image colors look more natural for the scene you are shooting.



- Press the **[WB]** button, choose **[Auto]** in the menu, and choose the desired option (📖30).
- The option you configured is now displayed.

[WB] Auto	Automatically sets the optimal white balance for the shooting conditions.
[Daylight] Daylight	For shooting outdoors in fair weather.
[Shade] Shade	For shooting in the shade.
[Cloudy] Cloudy	For shooting in cloudy weather or at twilight.
[Tungsten] Tungsten light	For shooting under ordinary incandescent lighting.
[White fluorescent] White fluorescent light	For shooting under white fluorescent lighting.
[Flash] Flash	For shooting with the flash.
[Underwater] Underwater	For shooting underwater.
[Custom] Custom	For manually setting a custom white balance (📖83).
[K] Color temp.	For manually setting a white balance color temperature (📖85).

Custom White Balance

► Still Images ► Movies

For image colors that look natural under the light in your shot, adjust white balance to suit the light source where you are shooting. Set the white balance under the same light source that will illuminate your shot.

1 Shoot a white object.

- Aim the camera at a sheet of paper or other plain white subject, so that white fills the screen.
- Focus manually and shoot (📖89).

2 Choose [Custom WB].

- Choose [Custom WB] on the **[CAMERA]** tab, and then press the **[WB]** button.
- The custom white balance selection screen will appear.

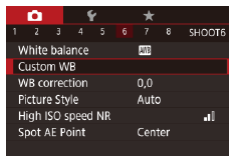

3 Load the white data.

- Select your image from step 1, and then press **[WB]**.
- On the confirmation screen, press the **[OK]** buttons to choose [OK], press the **[WB]** button, and then press the **[WB]** button again.
- Press the **[MENU]** button to close the menu.



4 Choose [K].

- Follow the steps in “Capturing Natural Colors (White Balance)” (📖83) to choose **[K]**.



Before Use

Basic Guide

Advanced Guide

Camera Basics

Auto Mode / Hybrid Auto Mode

Other Shooting Modes

P Mode

Tv, Av, M, and C Mode

Playback Mode

Wireless Features

Setting Menu

Accessories

Appendix

Index





- Shots in step 1 that are too bright or dark may prevent you from setting the white balance correctly.
- A message is displayed if you specify an image in step 3 that is not suitable for loading white data. Choose [Cancel] to choose a different image. Choose [OK] to use that image for loading white data, but note that it may not produce a suitable white balance.
- If [Unselectable image.] is displayed in step 3, choose [OK] to clear the message and specify another image.
- If [Set WB to “”] is displayed in step 3, press the [] button to return to the menu screen, and then choose .



- Instead of a white object, a gray chart or 18% gray reflector (commercially available) can produce a more accurate white balance.
- The current white balance and related settings are disregarded when you shoot in step 1.

Manually Correcting White Balance

► Still Images ► Movies

You can correct white balance. This adjustment can match the effect of using a commercially available color temperature conversion filter or color-compensating filter.



1 Configure the setting.

- Follow the steps in “Capturing Natural Colors (White Balance)” (📖83) to choose [WB].
- Turn the [] dial to adjust the correction level for B and A.

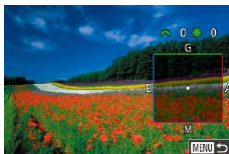

2 Configure advanced settings.

- To configure more advanced settings, press the [MENU] button and adjust the correction level by turning the [][] dials or pressing the [][][][] buttons.
- To reset the correction level, press the [] button.
- Press the [] button to complete the setting.
- Once the setting is complete, [WB] is displayed.



- The camera will retain white balance correction levels even if you switch to another white balance option (by following steps in “Capturing Natural Colors (White Balance)” (📖83)), but correction levels will be reset if you record custom white balance data.



- B: blue; A: amber; M: magenta; G: green
- You can customize camera operation so that the B and A adjustment screen is accessed simply by turning the [] or [] dial (📖105).
- One level of blue/amber correction is equivalent to about 5 mireds on a color temperature conversion filter. (Mired: Color temperature unit representing color temperature conversion filter density)
- You can also configure this setting by choosing MENU (📖31) > [📷] tab > [WB correction].



- You can also choose the correction level by touching or dragging the bar in step 1 or the frame in step 2.

Before Use

Basic Guide

Advanced Guide

Camera Basics

Auto Mode /
Hybrid Auto Mode

Other Shooting Modes

P Mode

Tv, Av, M, and C Mode

Playback Mode

Wireless Features

Setting Menu

Accessories

Appendix

Index



Manually Setting White Balance Color Temperature

► Still Images ► Movies

A value can be set representing the white balance color temperature.



- Follow the steps in "Capturing Natural Colors (White Balance)" (83) to choose [K].
- Press the [WB] button, and then adjust the setting by pressing the [L/R] buttons or turning the [DIAL] dial.



- Color temperature can be set at 100 K increments in a range of 2,500 – 10,000 K.

Customizing Colors (Picture Style)

► Still Images ► Movies

Choose a Picture Style with color settings that express moods or subjects well. Eight Picture Styles are available, and each can be further customized.



- Press the [P] button, choose [Picture Style] in the menu, and choose the desired option (30).

Auto	The color tone is adjusted automatically to suit the scene. The colors look vivid, especially for blue skies, greenery, and sunsets in nature, outdoor, and sunset scenes.
Standard	The image looks vivid, sharp, and crisp. Suitable for most scenes.
Portrait	For smooth skin tones, with slightly less sharpness. Suited for close-up portraits. To modify skin tones, adjust [Color tone] (86).
Landscape	For vivid blues and greens, and very sharp and crisp images. Effective for impressive landscapes.
Fine Detail	For detailed rendering of fine subject contours and subtle textures. Makes images slightly more vivid.
Neutral	For retouching later on a computer. Makes images subdued, with lower contrast and natural color tones.
Faithful	For retouching later on a computer. Faithfully reproduces the actual colors of subjects as measured in daylight with a color temperature of 5200K. Makes images subdued, with lower contrast.

Before Use

Basic Guide

Advanced Guide

Camera Basics

Auto Mode /
Hybrid Auto Mode

Other Shooting Modes

P Mode

Tv, Av, M, and C Mode

Playback Mode

Wireless Features





Setting Menu

Accessories





Appendix

Index







 Monochrome	Creates black and white images.
   User Def.	Add a new style based on presets such as [Portrait] or [Landscape] or a Picture Style file, and then adjust it as needed (85).





- Default [Auto] settings are used for , , and  until you add a Picture Style.
- You can also configure this setting by accessing MENU (31) >  tab > [Picture Style].

Customizing Picture Styles

Customize these Picture Style settings as needed.

Sharpness	 Strength	Adjust the level of edge enhancement. Choose lower values to soften (blur) subjects, or higher values to sharpen them.
	 Fineness	Indicates the edge thinness that enhancement applies to. Choose lower values for more enhanced details.
	 Threshold	Contrast threshold between edges and surrounding image areas, which determines edge enhancement. Choose lower values to enhance edges that do not stand out much from surrounding areas. Note that with lower values, noise may also be emphasized.
 Contrast		Adjust the contrast. Choose lower values to decrease the contrast, or higher values to increase it.
 Saturation* ¹		Adjust the intensity of colors. Choose lower values to make colors faded, or higher values to make them deeper.

 Color tone* ¹	Adjust skin color tone. Choose lower values to produce redder hues, or higher values to produce yellower hues.
 Filter effect* ²	Emphasize white clouds, the green of trees, or other colors in monochrome images. N: Normal black-and-white image with no filter effects. Ye: The blue sky will look more natural, and the white clouds will look crisper. Or: The blue sky will look slightly darker. The sunset will look more brilliant. R: The blue sky will look quite dark. Fall leaves will look crisper and brighter. G: Skin tones and lips will appear muted. Green tree leaves will look crisper and brighter.
 Toning effect* ²	Choose from the following monochrome hues: [N:None], [S:Sepia], [B:Blue], [P:Purple], or [G:Green].

*¹ Not available with .

*² Only available with .



- In [Sharpness], [Fineness] and [Threshold] settings are not applied to movies.

Before Use

Basic Guide

Advanced Guide

Camera Basics

Auto Mode /
Hybrid Auto Mode

Other Shooting Modes

P Mode

Tv, Av, M, and C Mode

Playback Mode

Wireless Features

Setting Menu

Accessories

Appendix

Index



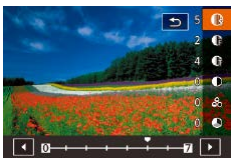

1 Access the setting screen.

- Choose a Picture Style as described in “Customizing Colors (Picture Style)” (📖85).
- Press the [P] button.

2 Configure the setting.

- Press the [▲][▼] buttons to choose an item, and then choose an option by pressing the [◀][▶] buttons or turning the [DIAL] dial.
- To undo any changes, press the [P] button.
- When finished, press the [SET] button.



- [Filter effect] results are more noticeable with higher [Contrast] values.

Saving Customized Picture Styles

Save presets (such as [P] or [L]) that you have customized as new styles. You can create several Picture Styles with different settings for parameters such as sharpness or contrast.

1 Select a user-defined style number.

- Choose [1], [2], or [3] as described in “Customizing Colors (Picture Style)” (📖85).
- Press the [P] button.



2 Select a style to modify.

- Press the [◀][▶] buttons or turn the [DIAL] dial to choose the Picture Style that serves as the basis.

3 Customize the style.

- Press the [▲][▼] buttons to choose an item to modify, and then customize it, either by pressing the [◀][▶] buttons or turning the [DIAL] dial.
- When finished, press the [SET] button.



- Using the CameraWindow application (📖189), you can also add Picture Styles saved on a computer to the camera. For instructions, refer to the CameraWindow Help.



- You can also choose a Picture Style to modify by touching [P] in step 2.

Before Use

Basic Guide

Advanced Guide

Camera Basics

Auto Mode /
Hybrid Auto Mode

Other Shooting Modes

P Mode

Tv, Av, M, and C Mode

Playback Mode

Wireless Features

Setting Menu

Accessories

Appendix

Index



Shooting Range and Focusing

Shooting at Preset Focal Lengths (Step Zoom)

▶ Still Images ▶ Movies

Shoot at common focal lengths in a range of 24 – 72 mm (35mm film equivalent).

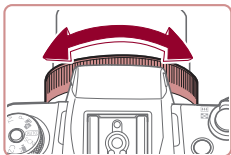

1 Assign [ZOOM] to the [Fn] ring (105).

2 Choose a focal length.

- To change the focal length from 24 to 28 mm, turn the [Fn] ring counterclockwise. Turn the [Fn] ring counterclockwise to zoom in or clockwise to zoom out.



- Step zoom is not available when recording movies even if you turn the [Fn] ring.



- When you are using digital zoom (142), you cannot adjust the zoom factor by turning the [Fn] ring counterclockwise. However, you can set the focal length to 72 mm by turning it clockwise.

Shooting Close-Ups (Macro)

▶ Still Images ▶ Movies

To restrict the focus to subjects at close range, set the camera to [Macro]. For details on the range of focus, see “Lens” (223).

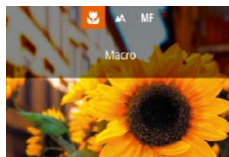

- Press the [Fn] button, choose [Macro] (either press the [Fn] buttons or turn the [Fn] dial), and then press the [Fn] button.
- Once the setting is complete, [Macro] is displayed.



- If the flash fires, vignetting may occur.



- To prevent camera shake, try mounting the camera on a tripod and shooting with the camera set to [Macro] (43).



- You can also configure this setting by pressing the [Fn] button, touching [Macro], and then touching it again.

Before Use

Basic Guide

Advanced Guide

Camera Basics

Auto Mode /
Hybrid Auto Mode

Other Shooting Modes

P Mode

Tv, Av, M, and C Mode

Playback Mode

Wireless Features

Setting Menu

Accessories

Appendix

Index



Shooting in Manual Focus Mode

▶ Still Images ▶ Movies

When focusing is not possible in AF mode, use manual focus. You can specify the general focal position and then press the shutter button halfway to have the camera determine the optimal focal position near the position you specified. For details on the range of focus, see “Lens” (p.223).



1 Choose [MF].

- Press the [◀] button, choose [MF] (either press the [◀][▶] buttons or turn the [SET] dial), and then press the [SET] button.
- [MF] and the MF indicator are displayed.



(1)

2 Specify the general focal position.

- Referring to the on-screen MF indicator (1, which shows the distance and focal position) and the magnified display, press the [▲][▼] buttons to specify the general focal position, and then press the [SET] button.
- To adjust the magnification, press the [▶] button.
- During magnified display, you can move the focusing frame by pressing the [±] button and then the [▲][▼][◀][▶] buttons.

3 Fine-tune the focus.

- Press the shutter button halfway or touch [AF] to have the camera fine-tune the focal position (Safety MF).
- To cancel manual focus, choose [▲] in step 1.



- When you focus manually, the AF method (p.91) is [1-point AF] and cannot be changed.
- Focusing is possible when using the digital zoom (p.42) or digital tele-converter (p.91), or when using a TV as a display (p.183), but the magnified display will not appear.



- To focus more accurately, try attaching the camera to a tripod to stabilize it.
- You can enlarge or hide the magnified display area by adjusting MENU (p.31) > [4] tab > [MF-Point Zoom] settings.
- To deactivate automatic focus fine-tuning when the shutter button is pressed halfway, choose MENU (p.31) > [4] tab > [Safety MF] > [Off].



- You can move the focusing frame by dragging on the screen in step 2.
- You can lock the focus during movie recording by touching [AF]. [MF] is then displayed.

Before Use

Basic Guide

Advanced Guide

Camera Basics

Auto Mode / Hybrid Auto Mode

Other Shooting Modes

P Mode

Tv, Av, M, and C Mode

Playback Mode

Wireless Features

Setting Menu

Accessories

Appendix

Index



Easily Identifying the Focus Area (MF Peaking)

▶ Still Images ▶ Movies

Edges of subjects in focus are displayed in color to make manual focusing easier. You can adjust the colors and the sensitivity (level) of edge detection as needed.

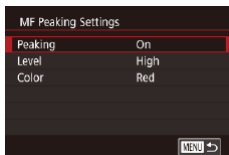

1 Access the setting screen.

- Press the [MENU] button, choose [MF Peaking Settings] on the [Q4] tab, choose [Peaking], and then choose [On] (p.31).

2 Configure the setting.

- Choose a menu item to configure, and then choose the desired option (p.31).



- Colors displayed for MF peaking are not recorded in your shots.



2 Configure the setting.

- Press the [Q5] button, and then adjust the setting by pressing the [◀] [▶] buttons or turning the [DIAL] dial.



- Focus bracketing is only available in [S] mode (p.96).
- Continuous shooting (p.44) is not available in this mode.



- You can also access the setting screen in step 2 by pressing the [MENU] button in step 2 of "Shooting in Manual Focus Mode" (p.89).
- Three shots are taken, regardless of any quantity specified in [C] (p.43).

Focus Bracketing (Focus-BKT Mode)

▶ Still Images ▶ Movies

Three consecutive images are captured each time you shoot, with the first one at the focal distance you set manually and the others at farther and nearer focal positions determined by presets. The distance from your specified focus can be set in three levels.

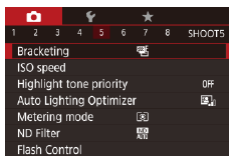

1 Choose [Q5].

- Press the [MENU] button, choose [Bracketing] on the [Q5] tab, and then choose [4] (p.31).

Before Use

Basic Guide

Advanced Guide

Camera Basics

Auto Mode / Hybrid Auto Mode

Other Shooting Modes

P Mode

Tv, Av, M, and C Mode

Playback Mode

Wireless Features

Setting Menu

Accessories

Appendix

Index



Digital Tele-Converter

▶ Still Images ▶ Movies

The focal length of the lens can be increased by approximately 1.6x or 2.0x. This can reduce camera shake because the shutter speed is faster than it would be if you zoomed (including using digital zoom) in to the same zoom factor.



- Press the [MENU] button, choose [Digital Zoom] on the [CAMERA] tab, and then choose the desired option (31).
- The view is enlarged and the zoom factor is displayed on the screen.



- The shutter speed may be equivalent when you move the zoom lever all the way toward [TELE] for maximum telephoto, and when you zoom in to enlarge the subject to the same size following step 2 in "Zooming In Closer on Subjects (Digital Zoom)" (42).

Choosing the AF Method

▶ Still Images ▶ Movies

Change the auto focus (AF) mode to suit shooting conditions.



- Press the [MENU] button, choose [AF] in the menu, and choose the desired option (31).



- You can also configure this setting by accessing MENU (31) > [CAMERA] tab > [AF method].

1-point AF

▶ Still Images ▶ Movies

The camera focuses using a single AF frame. Effective for reliable focusing. You can also move the frame by touching the screen (95).



- A yellow frame is displayed with [!] if the camera cannot focus when you press the shutter button halfway.



- To compose shots so that subjects are positioned at the edge or in a corner, first aim the camera to capture the subject in an AF frame, and then hold the shutter button halfway down. As you continue to hold the shutter button halfway, recompose the shot as desired, and then press the shutter button all the way down (Focus Lock).
- To return the AF frame to the original position in the center, keep the [AF-C] button held down.

Moving and Resizing AF Frames (1-point AF)

▶ Still Images ▶ Movies

When you want to change the position or size of the AF frame, set the AF method to [1-point AF].



1 Move the AF frame.

- Pressing the [AF-C] button displays the AF frame in orange.
- Turn the [AF-ON] or [AF-ON] dial to move the AF frame, and press the [▲][▼][◀][▶] buttons to fine-tune the position.
- To return the AF frame to the original position in the center, press the [MENU] button.

Before Use

Basic Guide

Advanced Guide

Camera Basics

Auto Mode / Hybrid Auto Mode

Other Shooting Modes

P Mode

Tv, Av, M, and C Mode

Playback Mode

Wireless Features

Setting Menu

Accessories

Appendix

Index





2 Resize the AF frame.

- To reduce the AF frame size, turn the  ring. Turn it again to restore it to the original size.





3 Finish the setup process.

- Press the .



- AF frames are displayed at normal size when you use the digital zoom () or digital tele-converter (.



- You can also return the AF frame to the original position in the center by holding down the  button.
- You can link the Spot AE Point frame to the AF frame (.
- You can also configure the AF frame size by pressing the  button and choosing [AF Frame Size] on the  tab ()31).

+Tracking

► Still Images ► Movies

- After you aim the camera at the subject, a white frame is displayed around the face of the main subject as determined by the camera. You can also choose subjects yourself ()95).
- When the camera detects movement, frames will follow moving subjects, within a certain range.
- Frames turn green after you press the shutter button halfway and the camera focuses.
- When no faces are detected, pressing the shutter button halfway displays green frames around other areas in focus.



- Examples of faces that cannot be detected:
 - Subjects that are distant or extremely close
 - Subjects that are dark or light
 - Faces in profile, at an angle, or partly hidden
- The camera may misinterpret non-human subjects as faces.
- Focusing is not possible on faces detected at the edge of the screen (which are displayed with gray frames), even when you press the shutter button halfway.



Smooth Zone AF

- The camera focuses within your designated area. Effective when the subject is hard to capture with +Tracking] or [1-point AF], because you can specify where to focus. The camera will focus within the white frame displayed. You can move the white frame by dragging it or touching the screen.
- When you press the shutter button halfway, green frames are displayed around positions in focus within the white frame.



- A yellow frame is displayed with  if the camera cannot focus when you press the shutter button halfway.



- Blue frames are displayed around positions in focus when you select MENU ()31) >  > [AF operation] > [Servo AF].

Before Use

Basic Guide

Advanced Guide

Camera Basics

Auto Mode /
Hybrid Auto Mode

Other Shooting Modes

P Mode

Tv, Av, M, and C Mode

Playback Mode

Wireless Features

Setting Menu

Accessories

Appendix

Index



Shooting with Servo AF

▶ Still Images ▶ Movies

This mode helps avoid missing shots of subjects in motion, because the camera continues to focus on the subject and adjust the exposure as long as you press the shutter button halfway.

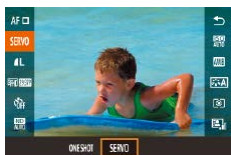

1 Configure the setting.

- Press the **[AF-ON]** button, choose [ONE SHOT] in the menu, and then choose [SERVO] (📖30).

2 Focus.

- The focus and exposure are maintained where the blue AF frame is displayed while you are pressing the shutter button halfway.



- The camera may not be able to shoot while focusing, even if you press the shutter button all the way down. Keep holding down the shutter button as you follow the subject.
- A yellow frame is displayed with **[!]** if the camera cannot focus when you press the shutter button halfway.
- Using the self-timer (📖42) will restrict the AF mode to [ONE SHOT].
- Choosing MENU (📖31) > [CAMERA] tab > [AF Frame Size] > [Small] will restrict the mode to [ONE SHOT].



- Exposure is not locked in Servo AF mode when you press the shutter button halfway but is determined the moment you shoot, regardless of the metering mode (📖79) setting.
- Continuous shooting (📖44) with auto focus is possible by specifying Servo AF. Note that continuous shooting is slower at this time.
- Depending on the distance to the subject and the subject's speed, the camera may not be able to achieve correct focus.
- You can also configure this setting by accessing MENU (📖31) > [CAMERA] tab > [AF operation].

Changing the Focus Setting

▶ Still Images ▶ Movies

You can change default camera operation of constantly focusing on subjects it is aimed at, even when the shutter button is not pressed. Instead, you can limit camera focusing to the moment you press the shutter button halfway.



- Press the **[MENU]** button, choose [Continuous AF] on the [CAMERA] tab, and then choose [Disable] (📖31).

Enable	Helps avoid missing sudden photo opportunities, because the camera constantly focuses on subjects until you press the shutter button halfway.
Disable	Conserves battery power, because the camera does not focus constantly.



- Choosing MENU (📖31) > [CAMERA] tab > [AF Frame Size] > [Small] will restrict the mode to [Disable].

Before Use

Basic Guide

Advanced Guide

Camera Basics

Auto Mode /
Hybrid Auto Mode

Other Shooting Modes

P Mode

Tv, Av, M, and C Mode

Playback Mode

Wireless Features

Setting Menu

Accessories

Appendix

Index



Fine-Tuning the Focus

▶ Still Images ▶ Movies

You can fine-tune the focus after autofocusing by turning the continuous ring.

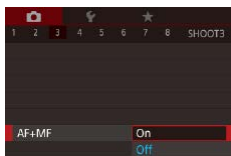

1 Configure the setting.

- Press the [MENU] button, choose [AF+MF] on the [CAM] tab, and then choose [On] (📖31).

2 Focus.

- Press the shutter button halfway to focus on the subject, and continue holding the button halfway down.

3 Fine-tune the focus.

- Turn the [L] ring. Referring to the on-screen MF indicator (which shows the distance and focal position) and the magnified display, turn the [L] ring to adjust the focus.
- To enlarge or reduce the magnified display, press the [M] button.
- To cancel focusing, release the shutter button.

4 Shoot.

- Press the shutter button all the way down to shoot.



- Cannot be used with Servo AF (📖93).

Choosing a Person to Focus On (Face Select)

▶ Still Images ▶ Movies

You can shoot after choosing a specific person's face to focus on.

1 Set the AF method to [L+Tracking] (📖91).

2 Enter Face Select mode.

- Aim the camera at the person's face and press the [L+Tracking] button.
- After [Face Select : On] is displayed, a face frame [L] is displayed around the face detected as the main subject.
- Even if the subject moves, the face frame [L] follows the subject within a certain range.
- If a face is not detected, [L] is not displayed.

3 Choose the face to focus on.

- To switch the face frame [L] to another detected face, press the [L+Tracking] button.
- Once you cycle through all detected faces, [Face Select : Off] is displayed, followed by the selected AF method screen.

4 Shoot.

- Press the shutter button halfway. After the camera focuses, [L] changes to [L].
- Press the shutter button all the way down to shoot.



Before Use

Basic Guide

Advanced Guide

Camera Basics

Auto Mode /
Hybrid Auto Mode

Other Shooting Modes

P Mode

Tv, Av, M, and C Mode

Playback Mode

Wireless Features

Setting Menu

Accessories

Appendix

Index





- When [Face ID] is set to [On], only the name of the registered person chosen as the main subject is displayed, even if other registered people have been detected. However, their names will be recorded in the still images (📖45).

Choosing Subjects to Focus On (Touch AF)

▶ Still Images ▶ Movies

You can shoot after choosing a person's face or another subject to focus on.



1 Set the AF method to [L+Tracking] (📖91).

2 Choose a person's face or another subject to focus on.

- Touch the subject or person on the screen.
- When the subject is detected, the camera beeps and [L] is displayed. Focus is maintained even if the subject moves.
- To cancel Touch AF, touch [L].



3 Shoot.

- Press the shutter button halfway. After the camera focuses, [L] changes to a green [L].
- Press the shutter button all the way down to shoot.



- If you prefer not to shoot when you touch the screen, choose [MENU] > [2] tab > [Touch Shutter] > [Touch Shutter] > [Disable] (📖31).
- Tracking may not be possible when subjects are too small or move too rapidly, or when there is inadequate contrast between subjects and the background.
- Even if you are shooting in [M] mode (📖88), the camera will revert to [A] mode if you touch the screen to specify where to focus.
- To keep the frame in the same position (where you touched) after shooting when [Touch Shutter] is set to [Enable] (📖44), choose MENU (📖31) > [2] tab > [Touch Shutter] > [AF frame pos'n] > [Touch point].

Shooting with AF Lock

▶ Still Images ▶ Movies

The focus can be locked. After you lock the focus, the focal position will not change even when you release your finger from the shutter button.

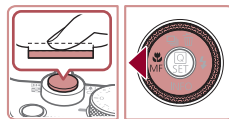

1 Lock the focus.

- With the shutter button pressed halfway, press the [L] button.
- The focus is now locked, and [MF] and the MF indicator are displayed.
- To unlock the focus, hold the shutter button halfway down and press the [L] button again.

2 Compose the shot and shoot.



- Cannot be used with Touch Shutter (📖44).

Before Use

Basic Guide

Advanced Guide

Camera Basics

Auto Mode / Hybrid Auto Mode

Other Shooting Modes

P Mode

Tv, Av, M, and C Mode

Playback Mode

Wireless Features

Setting Menu

Accessories

Appendix

Index



Flash

Changing the Flash Mode

► Still Images ► Movies

You can change the flash mode to match the shooting scene. For details on the flash range, see “Flash” (p.223).

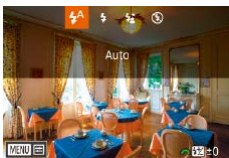

1 Lift the flash.

2 Configure the setting.

- Press the [▶] button, choose a flash mode (either press the [◀][▶] buttons or turn the [DIAL] dial), and then press the [OK] button.
- The option you configured is now displayed.



- The setting screen cannot be accessed by pressing the [▶] button when the flash is lowered. Lift the flash in advance.
- If the flash fires, vignetting may occur.

Auto

Fires automatically in low-light conditions.

On

Fires for each shot.

Slow Synchro

Fires to illuminate the main subject (such as people) while shooting at a slower shutter speed to illuminate backgrounds out of flash range.



- In [Flash] mode, mount the camera on a tripod or take other measures to keep it still and prevent camera shake. Additionally, you should set [IS Mode] to [Off] when using a tripod or other means to secure the camera (p.53).
- In [Flash] mode, even after the flash fires, ensure that the main subject does not move until the shutter sound is finished playing.

Off

For shooting without the flash.



- If a blinking [Flash] icon is displayed when you press the shutter button halfway in camera-shake inducing, low-light conditions, mount the camera on a tripod or take other measures to keep it still.



- You can also configure this setting by pressing the [▶] button, touching the desired option, and then touching it again.

Before Use

Basic Guide

Advanced Guide

Camera Basics

Auto Mode /
Hybrid Auto Mode

Other Shooting Modes

P Mode

Tv, Av, M, and C Mode

Playback Mode

Wireless Features

Setting Menu

Accessories

Appendix

Index



Adjusting the Flash Exposure Compensation

▶ Still Images ▶ Movies

Just as with regular exposure compensation (📖78), you can adjust the flash exposure from -2 to +2 stops, in 1/3-stop increments.

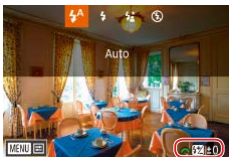

- Raise the flash, press the [▶] button and immediately turn the [🔍] dial to choose the compensation level, and then press the [⏏] button.
- The correction level you specified is now displayed.



- When there is a risk of overexposure, the camera automatically adjusts the shutter speed or aperture value for flash shots to reduce washed-out highlights and shoot at optimal exposure. However, you can deactivate automatic adjustment of the shutter speed and aperture value by accessing MENU (📖31) and choosing [📷5] tab > [Flash Control] > [Safety FE] > [Off].
- You can also configure the flash exposure compensation by accessing MENU (📖31) and choosing [📷5] tab > [Flash Control] > [Flash Exp. Comp].
- You can also access the [Built-in Flash Settings] screen (📖31) as follows (except when an optional external flash is mounted).
 - Press and hold the [▶] button for at least one second.
 - When the flash is up, press the [▶] button and immediately press the [MENU] button.

Shooting with FE Lock

▶ Still Images ▶ Movies

Just as with the AE lock (📖78), you can lock the exposure for flash shots.

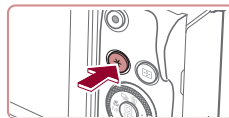

- FE: Flash Exposure

1 Raise the flash and set it to [🔍] (📖96).

2 Lock the flash exposure.

- Aim the camera at the subject to shoot with the exposure locked, and then press the [★] button.
- The flash fires, and when [★] is displayed, the flash output level is retained.
- To unlock FE, press the [★] button again. [★] is no longer displayed.

3 Compose the shot and shoot.

Before Use

Basic Guide

Advanced Guide

Camera Basics

Auto Mode / Hybrid Auto Mode

Other Shooting Modes

P Mode

Tv, Av, M, and C Mode

Playback Mode

Wireless Features

Setting Menu

Accessories

Appendix

Index



Changing the Flash Timing

▶ Still Images ▶ Movies

Change the timing of the flash and shutter release as follows.

1 Access the setting screen.

- Press the [MENU] button, choose [Flash Control] on the [5] tab, and then press the [Fn] button (31).

2 Configure the setting.

- Choose [Shutter Sync.], and then choose the desired option (31).

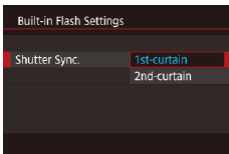

1st-curtain	The flash fires immediately after the shutter opens.
2nd-curtain	The flash fires immediately before the shutter closes.

Other Settings

Changing the IS Mode Settings

▶ Still Images ▶ Movies

You can keep image stabilization off until the moment you shoot.

- Follow the steps in “Deactivating Image Stabilization” (53) to choose [Shoot Only].

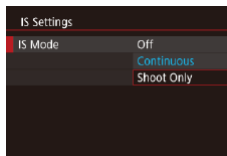

Before Use

Basic Guide

Advanced Guide

Camera Basics

Auto Mode /
Hybrid Auto Mode

Other Shooting Modes

P Mode

Tv, Av, M, and C Mode

Playback Mode

Wireless Features

Setting Menu

Accessories

Appendix

Index



Tv, Av, M, and C Mode

Take smarter, more sophisticated shots, and customize the camera for your shooting style

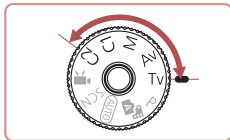

- Instructions in this chapter apply to the camera as set to the respective mode.

Specific Shutter Speeds ([Tv] Mode)

► Still Images ► Movies

Set your preferred shutter speed before shooting as follows. The camera automatically adjusts the aperture value to suit your shutter speed. For details on available shutter speeds, see “Shutter” (📖223).

1 Enter [Tv] mode.

- Hold down the mode dial release button and turn the mode dial to [Tv].



2 Set the shutter speed.

- Turn the [S] dial to set the shutter speed.



- In conditions requiring slower shutter speeds, there may be a delay before you can shoot again, as the camera processes images to reduce noise.
- When shooting at low shutter speeds on a tripod, you should set [IS Mode] to [Off] (📖53).
- The speed you set may be lowered automatically as needed if the flash fires.
- Orange display of the aperture value when you press the shutter button halfway indicates that the optimum exposure has not been obtained. Adjust the shutter speed until the aperture value is displayed in white, or use safety shift (📖100).



- [Tv]: Time value

Before Use

Basic Guide

Advanced Guide

Camera Basics

Auto Mode /
Hybrid Auto Mode

Other Shooting Modes

P Mode

Tv, Av, M, and C Mode

Playback Mode

Wireless Features

Setting Menu

Accessories

Appendix

Index



Specific Aperture Values ([Av] Mode)

▶ Still Images ▶ Movies

Set your preferred aperture value before shooting as follows. The camera automatically adjusts the shutter speed to suit your aperture value. For details on available aperture values, see “Aperture” (📖223).

1 Enter [Av] mode.

- Hold down the mode dial release button and turn the mode dial to [Av].



2 Set the aperture value.

- Turn the [🔆] dial to set the aperture value.



- Orange display of the shutter speed when you press the shutter button halfway indicates that the optimum exposure has not been obtained. Adjust the aperture value until the shutter speed is displayed in white, or use safety shift (see below).



- [Av]: Aperture value (size of the opening made by the diaphragm in the lens)
- In [Tv] and [Av] modes, press the [MENU] button and set [Safety shift] on the [📷] tab to [On] (📖31) to have the camera automatically adjust the shutter speed and aperture value when there are exposure problems, so that you can shoot at the optimum exposure. However, safety shift is disabled when the flash fires.

Specific Shutter Speeds and Aperture Values ([M] Mode)

▶ Still Images ▶ Movies

Follow these steps before shooting to set your preferred shutter speed and aperture value to obtain the desired exposure. For details on available shutter speeds and aperture values, see “Shutter” (📖223) and “Aperture” (📖223).

1 Enter [M] mode.

- Hold down the mode dial release button and turn the mode dial to [M].

2 Configure the setting.

- Turn the [🔆] dial to set the shutter speed (1).
- Turn the [🔆] dial to set the aperture value (2).
- When the ISO speed is fixed, an exposure level mark (4) based on your specified values is shown on the exposure level indicator for comparison to the standard exposure level (3). The exposure level mark is shown as [◀] or [▶] when the difference from standard exposure exceeds 3 stops.
- The ISO speed is determined and screen brightness changes when you press the shutter button halfway after setting the ISO speed to [AUTO]. If standard exposure cannot be obtained with your specified shutter speed and aperture value, the ISO speed is displayed in orange.



- (1)
- (2)
- (3)
- (4)

Before Use

Basic Guide

Advanced Guide

Camera Basics

Auto Mode /
Hybrid Auto Mode

Other Shooting Modes

P Mode

Tv, Av, M, and C Mode

Playback Mode

Wireless Features

Setting Menu

Accessories

Appendix

Index





- After you set the shutter speed and aperture value, the exposure level may change if you adjust the zoom or recompose the shot.
- Screen brightness may change depending on your specified shutter speed and aperture value. However, screen brightness remains the same when the flash is up and the mode is set to [⚡].
- Image brightness may be affected by Auto Lighting Optimizer (📖82).



- **[M]**: Manual
- Calculation of optimum exposure is based on the specified metering method (📖79).
- The following operations are available when ISO speed is set to [AUTO].
 - Adjust exposure by turning the exposure compensation dial.
 - Press the [⌘] button to lock the ISO speed. Screen brightness changes accordingly.

Shooting Long Exposures (Bulb)

With bulb exposures, shots are exposed for as long as you hold down the shutter button.

1 Specify bulb exposure.

- Set the shutter speed to [BULB], following steps 1 – 2 in “Specific Shutter Speeds and Aperture Values ([M] Mode)” (📖100).

2 Shoot.

- Shots are exposed for as long as you hold the shutter button all the way down. The elapsed exposure time is displayed during exposure.



- Mount the camera on a tripod or take other measures to keep it still and prevent camera shake. In this case, also disable image stabilization (📖53).



- To avoid camera shake that may otherwise occur when pressing the shutter button directly, you can shoot remotely (📖165) or use an optional remote switch (📖186).



- When [Touch Shutter] is set to [Enable], shooting is started by touching the screen once and stopped by touching it again. Be careful not to move the camera when touching the screen.

Before Use

Basic Guide

Advanced Guide

Camera Basics

Auto Mode /
Hybrid Auto Mode

Other Shooting Modes

P Mode

Tv, Av, M, and C Mode

Playback Mode

Wireless Features

Setting Menu

Accessories

Appendix

Index



Adjusting the Flash Output

▶ Still Images ▶ Movies

Choose from the three flash levels in [Tv][Av][M] modes.

1 Specify the flash mode.

- Press the [MENU] button, choose [Flash Control] on the [5] tab, and then press the [Q] button (31).
- Press the [▲][▼] buttons or turn the [DIAL] dial to choose [Flash Mode], and then press the [Q] button.
- Press the [▲][▼] buttons or turn the [DIAL] dial to choose [Manual], and then press the [Q] button.

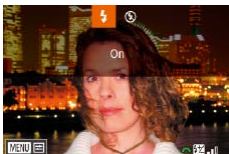

2 Configure the setting.

- Raise the flash, press the [▶] button and immediately turn the [DIAL] dial to choose the flash level, and then press the [Q] button.
- Once the setting is complete, the flash output level is displayed.
[Q]: Minimum, [Q]: Medium, [Q]: Maximum



- You can also set the flash level by accessing MENU (31) and choosing [5] tab > [Flash Control] > [Flash Output].
- You can also access the [Flash Control] screen (31) as follows.
 - Press and hold the [▶] button for at least one second.
 - When the flash is up, press the [▶] button and immediately press the [MENU] button.

Recording Movies at Specific Shutter Speeds and Aperture Values

▶ Still Images ▶ Movies

Set your preferred shutter speed, exposure, aperture value, and ISO speed.

For details on available shutter speeds, aperture values, and ISO speeds, see “Shutter” (223), “Aperture” (223), and “Changing the ISO Speed” (80).

1 Enter [M] mode.

- Hold down the mode dial release button and turn the mode dial to [M].
- Press the [Q] button, choose [M] in the menu, and then choose [M] (30).

2 Configure the settings.

- Turn the [DIAL] dial to set the shutter speed.
- Turn the [DIAL] dial to set the aperture value.



3 Shoot.

- Press the movie button.
- You can also adjust settings while recording, as described in step 2.



- Some shutter speeds may cause flickering on the screen when recording under fluorescent or LED lighting, which may be recorded.

Before Use

Basic Guide

Advanced Guide

Camera Basics

Auto Mode / Hybrid Auto Mode

Other Shooting Modes

P Mode

Tv, Av, M, and C Mode

Playback Mode

Wireless Features

Setting Menu

Accessories

Appendix

Index





- When the ISO speed is set to [AUTO], you can also adjust the exposure before recording by turning the exposure compensation dial.
- When the ISO speed is fixed, an exposure level mark based on your specified value is shown on the exposure level indicator for comparison to the standard exposure level. The exposure level mark is shown as [◀] or [▶] when the difference from standard exposure exceeds 3 stops.
- You can check the ISO speed in [AUTO] mode by pressing the shutter button halfway. If standard exposure cannot be obtained with your specified shutter speed and aperture value, the ISO speed is displayed in orange.



- Focus can be adjusted during recording by touching [AF] (to switch it to [MF]) and then pressing the [▲][▼] buttons.

Customizing Controls and Display

Customizing Display Information

Customize what screen is displayed when you press the [▼] button on the shooting screen. You can also customize what information is displayed.

1 Access the setting screen.

- On the [CAM1] tab, choose [Screen info/ toggle settings] or [VF info/ toggle settings] in [Shooting information display], and then press the [INFO] button (31).

2 Configure the setting.

- Press the [▲][▼] buttons or turn the [DISP.] dial to choose any screen you prefer not to display, and then press the [INFO] button to remove the [✓] mark. Pressing the [INFO] button again will add the [✓] mark, which indicates that it is selected for display.
- To return to the menu screen, press the [MENU] button.

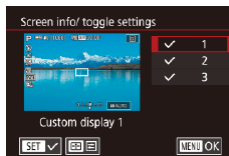

- An example of display with the options selected in step 2 is shown at left for reference.
- At least one option must be selected.

Before Use

Basic Guide

Advanced Guide

Camera Basics

Auto Mode /
Hybrid Auto Mode

Other Shooting Modes

P Mode

Tv, Av, M, and C Mode

Playback Mode

Wireless Features

Setting Menu

Accessories

Appendix

Index



Customizing the Information Displayed

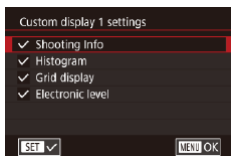

- Follow steps 1 – 2 in “Customizing Display Information” (📖 103) to choose [Custom display 1] or [Custom display 2], and then press the [INFO] button.
- Press the [▲][▼] buttons or turn the [DISP] dial to choose information to display, and then press the [INFO] button to add a [✓] mark.
- To see an example of display, press the [MENU] button to return to the [Screen info/ toggle settings] or [VF info/ toggle settings] screen.



- For a smaller grid pattern, access [CAMERA 1] tab > [Shooting information display] > [Grid display].
- The following settings are available by choosing [CAMERA 1] tab > [Shooting information display] > [Histogram].
 - Switch from a brightness histogram to an RGB histogram.
 - Reduce the size of the histogram displayed.

Configuring Touch & Drag AF

▶ Still Images ▶ Movies

With Touch & Drag AF, you can move the AF frame by touching or dragging the screen while looking through the viewfinder.

1 Access the setting screen.

- Choose [Touch & drag AF settings] on the [CAMERA 2] tab, and then press the [INFO] button (📖 31).

2 Configure the setting.

- Choose [Touch & drag AF], select [Enable], and then press the [INFO] button.

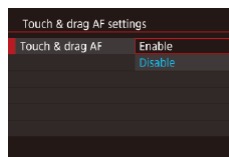

- When you choose MENU (📖 31) > [CAMERA 4] tab > [Touch Operation] > [Disable], [Touch & drag AF] is set to [Disable] and cannot be changed.
- AF frames may not be displayed correctly if you switch to viewfinder display while touching the screen. In this case, lift your finger and touch the screen again.

Before Use

Basic Guide

Advanced Guide

Camera Basics

Auto Mode /
Hybrid Auto Mode

Other Shooting Modes

P Mode

Tv, Av, M, and C Mode

Playback Mode

Wireless Features

Setting Menu

Accessories

Appendix

Index



Changing the Settings of Touch and Drag Operations

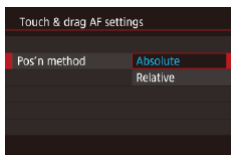

- Choose [Pos'n method] in step 1 of “Configuring Touch & Drag AF” (104) and choose the desired option.

Absolute	The AF frame moves to the touched or dragged position on the screen.
Relative	The AF frame moves in the direction you drag, by an amount corresponding to the amount you drag, no matter where you touch the screen.

Restricting the Area of the Screen Available for Touch and Drag Operations



- Follow step 1 in “Configuring Touch & Drag AF” (104) and choose [Active touch area].
- Choose the area that will be available for this feature.

Assigning Functions to Controls

▶ Still Images ▶ Movies

Reassign functions of the shutter button, [X] button, [AF] ring, [S] dial, or [M] dial, or assign common functions to the movie button or [M] button.

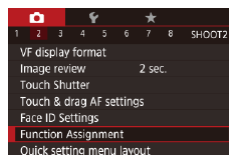

1 Access the setting screen.

- Press the [MENU] button, choose [Function Assignment] on the [2] tab, and then press the [M] button (31).

2 Configure the setting.

- Press the [▲][▼] buttons or turn the [S] dial, or turn the [M] dial, or assign common functions to the movie button or [M] button.
- When assigning the shutter button, [X] button, [AF] ring, [S] dial, or [M] dial, press the [▲][▼] buttons or turn the [S] dial to choose the shooting mode or the camera control, press the [◀][▶] buttons to choose the shooting mode or function, and then press the [M] button.
- When assigning the movie button or [M] button, press the [M] button, choose the function on the screen displayed (either press the [▲][▼][◀][▶] buttons or turn the [S] dial), and then press the [M] button.

Before Use

Basic Guide

Advanced Guide

Camera Basics

Auto Mode / Hybrid Auto Mode

Other Shooting Modes

P Mode

Tv, Av, M, and C Mode

Playback Mode

Wireless Features













Setting Menu

Accessories











Appendix

Index



Shutter button or  button	[AF/AE lock]	Enable exposure lock by pressing the  button, after focusing by pressing the shutter button halfway.
	[AE lock/AF]	Enable exposure lock by pressing the shutter button halfway, and focusing by pressing the  button.
	[AF/AF lock, no AE lock]	Enable focus lock by pressing the  button.
	[AE/AF, no AE lock]	Enable exposure compensation by pressing the shutter button halfway, and focusing by pressing the  button.
 ring,  dial, or  dial	Enable configuration of the assigned function in [Tv], [Av], [P], [M], or [Mn] mode by turning the  ring,  dial, or  dial.	
Movie button	Press the button to activate the assigned function.	
 button		



- To restore the default settings to the movie button and  button, choose  and .
- Icons labeled with a  sign indicate that the function is not available in the current shooting mode or under current function conditions.
- With [AF], each press of the assigned button adjusts and locks the focus, and [AF] is displayed on the screen.
- With , pressing the assigned button deactivates screen display. To restore the display, do any of the following.
 - Operate any camera control other than the power button
 - Hold the camera in another orientation
 - Open or close the screen
 - Raise or lower the flash
- You can still record movies in , , , or  mode even if you assign a function to the movie button.
- You can still choose the direction to move the camera in  mode if you assign a function to the  button.

Before Use

Basic Guide

Advanced Guide

Camera Basics

Auto Mode / Hybrid Auto Mode

Other Shooting Modes

P Mode

Tv, Av, M, and C Mode

Playback Mode

Wireless Features

Setting Menu

Accessories

Appendix

Index



Customizing the Quick Set Menu

▶ Still Images ▶ Movies

The display of Quick Set menu items can be customized.

Choosing Items to Include in the Menu

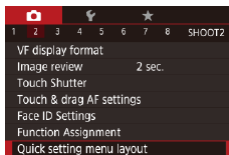

1 Access the setting screen.

- Press the [MENU] button, choose [Quick setting menu layout] on the [Q2] tab, and then press the [SET] button (131).

2 Choose icons to include in the menu.

- Press the [◀][▶] buttons or turn the [DIAL] dial to choose an icon, and then press the [SET] button to label icons you want to display in the Quick Set menu with [✓].
- Selected items (labeled with a [✓]) will be included in display.
- Items without a [✓] can be configured on the [Q2] tab of the menu screen.

3 Configure the setting.

- Press the [MENU] button, choose [OK] (either press the [◀][▶] buttons or turn the [DIAL] dial), and then press the [SET] button.



- Up to 11 items can be displayed in the menu.
- The screen in step 2 can also be accessed by holding down the [SET] button when the Quick Set menu is displayed.

Rearranging Menu Items



1 Access the setting screen.

- On the screen in step 2 of “Choosing Items to Include in the Menu” (107), press the [SET] button.
- Press the [▲][▼] buttons or turn the [DIAL] dial to choose an icon to move, and then press the [SET] button.
- Press the [▲][▼] buttons or turn the [DIAL] dial to choose the new position, and then press the [SET] button.

2 Configure the setting.

- Press the [MENU] button, choose [OK] (either press the [◀][▶] buttons or turn the [DIAL] dial), and then press the [SET] button.

Before Use

Basic Guide

Advanced Guide

Camera Basics

Auto Mode /
Hybrid Auto Mode

Other Shooting Modes

P Mode

Tv, Av, M, and C Mode

Playback Mode

Wireless Features

Setting Menu

Accessories

Appendix

Index



Saving Shooting Settings

▶ Still Images ▶ Movies

Save commonly used shooting modes and your configured function settings for reuse. To access saved settings later, simply turn the mode dial to [C1] or [C2]. Even settings that are usually cleared when you switch shooting modes or turn the camera off (such as self-timer settings) can be retained this way.

Settings That Can Be Saved

- Shooting modes ([P], [Tv], [Av], and [M])
- Items set in [P], [Tv], [Av], and [M] modes (📖78 – 📖100)
- Shooting menu settings
- Zoom positions
- Manual focus positions (📖89)
- My Menu settings (📖109)

1 Enter a shooting mode with settings you want to save, and change the settings as desired.

2 Configure the setting.

- Press the [MENU] button, choose [Custom shooting mode (C1, C2)] on the [Fn] tab, and then press the [SET] button.

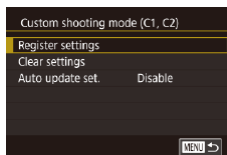
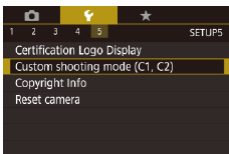

3 Save the settings.

- Press the [▲][▼] buttons or turn the [DIAL] dial to choose [Register settings], and then press the [SET] button.
- Press the [▲][▼] buttons or turn the [DIAL] dial to choose a custom shooting mode to assign, and then press the [SET] button.
- Press the [◀][▶] buttons or turn the [DIAL] dial to choose [OK] after the confirmation message, and then press the [SET] button.



- To edit saved settings (except their shooting mode), choose [C1] or [C2], change the settings, and then repeat steps 2 – 3. These setting details are not applied in other shooting modes.



- To reset saved settings to their defaults, choose [Clear settings] on the screen in step 3, press the [SET] button, and then choose the custom shooting mode. On the confirmation screen displayed next, choose [OK] and press the [SET] button.
- To automatically update your saved settings with any changes to settings that you make while shooting in [C1] or [C2] mode, set [Auto update set.] to [Enable] on the screen in step 3.

Before Use

Basic Guide

Advanced Guide

Camera Basics

Auto Mode /
Hybrid Auto Mode

Other Shooting Modes

P Mode

Tv, Av, M, and C Mode

Playback Mode

Wireless Features

Setting Menu

Accessories

Appendix

Index



Saving Commonly Used Shooting Menu Items (My Menu)

▶ Still Images ▶ Movies

You can save up to six commonly used shooting menu items on the [★1] tab. By customizing the [★1] tab, you can access these items quickly from a single screen.

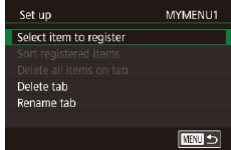
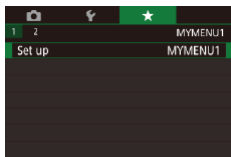
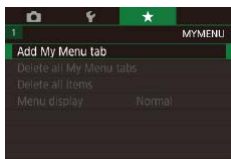

1 Access the setting screen.

- Press the [MENU] button, choose [Add My Menu tab] on the [★1] tab, and then press the [OK] button (p. 31).
- Press the [◀][▶] buttons or turn the [DISP] dial to choose [OK], and then press the [OK] button.
- Choose [Set up MYMENU1] on the [★1] tab, and then press the [OK] button.

2 Configure the setting.

- Press the [▲][▼] buttons or turn the [DISP] dial to choose [Select item to register], and then press the [OK] button.
- Press the [▲][▼] buttons or turn the [DISP] dial to choose a menu item to save (max. six items) and then press the [OK] button to save it.
 - [✓] is displayed.
 - To cancel saving, press the [OK] button. [✓] is no longer displayed.
- Press the [MENU] button.

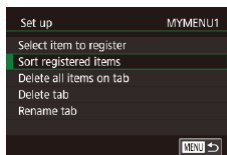

3 Rearrange menu items, as needed.

- Press the [▲][▼] buttons or turn the [DISP] dial to choose [Sort registered items], and then press the [OK] button.
- Choose a menu item to move (either press the [▲][▼] buttons or turn the [DISP] dial), and then press the [OK] button.
- Press the [▲][▼] buttons or turn the [DISP] dial to change the order, and then press the [OK] button.
- Press the [MENU] button.



- Grayed-out items in step 2 can also be specified, but they may not be available in some shooting modes.



- You can add up to [★5] by repeating this process from step 1.
- Choosing [Delete all items on tab] on the screen in step 2 will delete all items added to the tab.



- On the [Select item to register] screen for saving or clearing items, you can also touch items to select them.
- On the [Sort registered items] screen, you can also drag items to change the display order.

Before Use

Basic Guide

Advanced Guide

Camera Basics

Auto Mode / Hybrid Auto Mode

Other Shooting Modes

P Mode

Tv, Av, M, and C Mode

Playback Mode

Wireless Features

Setting Menu

Accessories

Appendix

Index



Renaming My Menu Tabs

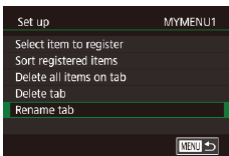

1 Choose [Rename tab].

- Following steps 2 – 3 in “Saving Commonly Used Shooting Menu Items (My Menu)” (109), choose [Rename tab] and press the [MENU] button.

2 Change the tab name.

- Use the keyboard displayed to enter the new tab name (32).
- Press the [◀][▶] buttons or turn the [DISP] dial to choose [Yes], and then press the [MENU] button.

Deleting a My Menu Tab

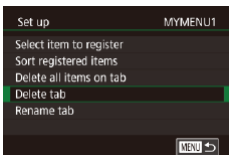

1 Choose [Delete tab].

- Following steps 2 – 3 in “Saving Commonly Used Shooting Menu Items (My Menu)” (109), choose [Delete tab] and press the [MENU] button.

2 Delete the item.

- Press the [◀][▶] buttons or turn the [DISP] dial to choose [OK], and then press the [MENU] button.

Deleting All My Menu Tabs or Items

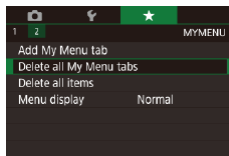

1 Choose an item.

- On the screen in step 1 of “Saving Commonly Used Shooting Menu Items (My Menu)” (109), choose [Delete all My Menu tabs] or [Delete all items], and then press the [MENU] button.

2 Delete the item.

- Choosing [Delete all My Menu tabs] will delete all My Menu tabs and restore the default [★] tab.
- Choosing [Delete all items] will delete all items added to tabs [★1] to [★5].

Customizing My Menu Tab Display

Specify which screen is displayed when the [MENU] button is pressed in Shooting mode.

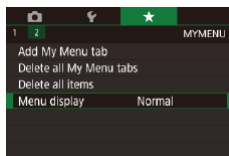

- On the screen in step 1 of “Saving Commonly Used Shooting Menu Items (My Menu)” (109), choose [Menu display], and then choose an item as desired.

Normal display	Display the most recent menu, as shown for your previous operation.
Display from My Menu tab	Start display from [★] tab screens.
Display only My Menu tab	Restrict display to [★] tab screens.

Before Use

Basic Guide

Advanced Guide

Camera Basics

Auto Mode /
Hybrid Auto Mode

Other Shooting Modes

P Mode

Tv, Av, M, and C Mode

Playback Mode

Wireless Features

Setting Menu

Accessories

Appendix

Index



Playback Mode

Have fun reviewing your shots, and browse or edit them in many ways

- To prepare the camera for these operations, press the [▶] button to enter Playback mode.



- It may not be possible to play back or edit images that were renamed or already edited on a computer, or images from other cameras.

Playback

▶ Still Images ▶ Movies

After shooting images or movies, you can view them on the screen as follows.

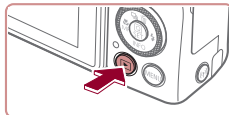

1 Enter Playback mode.

- Press the [▶] button.
- Your last shot is displayed.



2 Choose images.

- To view the previous image, press the [◀] button or turn the [◉] dial counterclockwise. To view the next image, press the [▶] button or turn the [◉] dial clockwise.
- Press and hold the [◀][▶] buttons to browse through images quickly.
- To access this screen (Scroll Display mode), turn the [◉] dial rapidly. In this mode, turn the [◉] dial to browse through images.
- To return to single-image display, press the [⏪] button.
- To browse images grouped by shooting date, press the [▲][▼] buttons in Scroll Display mode.
- Movies are identified by a [SET ▶] icon. To play movies, go to step 3.

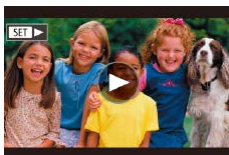
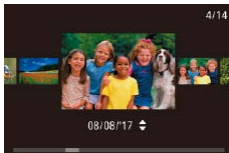

Before Use

Basic Guide

Advanced Guide

Camera Basics

Auto Mode / Hybrid Auto Mode

Other Shooting Modes

P Mode

Tv, Av, M, and C Mode

Playback Mode

Wireless Features

Setting Menu

Accessories

Appendix

Index





3 Play movies.

- To start playback, press the button to access the movie control panel, press the buttons to choose , and then press the button again.



(1)

4 Adjust the volume.

- Press the buttons to adjust the volume.
- To adjust the volume when the volume indicator (1) is no longer displayed, press the buttons.

5 Pause playback.

- To pause or resume playback, press the button.
- After the movie is finished, is displayed.



- To switch to Shooting mode from Playback mode, press the shutter button halfway.
- White lines indicating the aspect ratio are displayed when you view RAW images. These lines are shown on the top and bottom of images shot at an aspect ratio of **[16:9]** and on the left and right of images shot at an aspect ratio of **[4:3]** or **[1:1]**.
- To deactivate Scroll Display, choose MENU 31 > 5 tab > [Scroll Display] > [Off].
- To have the most recent shot displayed when you enter Playback mode, choose MENU 31 > 5 tab > [Resume] > [Last shot].
- To change the transition shown between images, access MENU 31 and choose your desired effect on the 5 tab > [Transition Effect].

Touch-Screen Operations

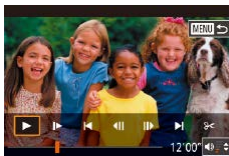
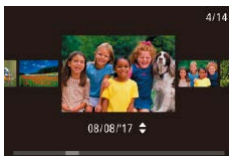
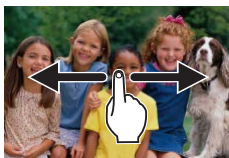

- To view the next image, drag left across the screen, and to view the previous image, drag right.

- To access Scroll Display mode, quickly drag left or right repeatedly.
- You can also browse through images in Scroll Display mode by dragging left or right.
- Touching the central image will restore single-image display.
- To browse images grouped by shooting date in Scroll Display mode, quickly drag up or down.
- To start movie playback, touch in step 2 of "Playback" 111).
- To adjust the volume during movie playback, quickly drag up or down across the screen.
- To stop playback, touch the screen. The screen shown at left is displayed, and the following operations are available.
- Touch to display the volume panel, and then touch to adjust the volume. At a volume of 0, is displayed.
- To switch frames, touch the scrollbar or drag left or right.
- To resume playback, touch .
- Touch to return to the screen in step 2 of "Playback" 111).

Before Use

Basic Guide

Advanced Guide

Camera Basics

Auto Mode / Hybrid Auto Mode

Other Shooting Modes

P Mode

Tv, Av, M, and C Mode

Playback Mode

Wireless Features

Setting Menu

Accessories

Appendix

Index



Switching Display Modes

▶ Still Images ▶ Movies

Press the [▼] button in Playback mode to switch from no information display to Info display 1 (basic info) and then to Info display 2 – 5 (details). Open the screen to activate it when the camera is on. This will deactivate the viewfinder. Similarly, close the screen (facing the camera body) to deactivate it and activate the viewfinder (📖21).



- Switching display modes is not possible while the camera is connected via Wi-Fi to devices other than printers.

Customizing the Shooting Information Displayed

Customize the information shown on each screen. For details on the information available, see “During Playback” (📖205).

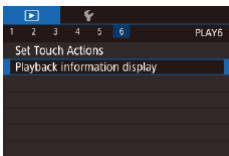

1 Access the setting screen.

- Press the [MENU] button, choose [Playback information display] on the [▶]6 tab, and then press the [ⓘ] button.



2 Choose information to display.

- Choose information to display, and then press the [ⓘ] button to add a [✓] mark.
- To return to the menu screen, press the [MENU] button.



- An example of display with the options selected in step 2 is shown at left for reference.

Overexposure Warning (for Image Highlights)

▶ Still Images ▶ Movies

Washed-out highlights in the image flash on the screen in detailed information display (📖113).

Histogram

▶ Still Images ▶ Movies

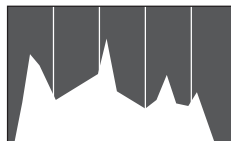

- Information displays 2 – 5 include a graph on the top called a histogram, which shows the distribution of brightness in images. The horizontal axis represents the degree of brightness, and the vertical axis, how much of the image is at each level of brightness. Viewing the histogram is a way to check exposure.

RGB Histogram, GPS Information Display

▶ Still Images ▶ Movies

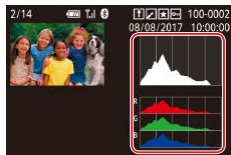

- Information display 3 includes an RGB histogram, showing the distribution of reds, greens, and blues in images. The horizontal axis represents R, G, or B brightness, and the vertical axis, how much of the image is at that level of brightness. Viewing this histogram enables you to check image color characteristics.

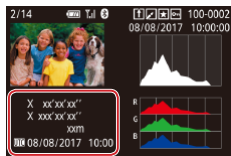

- Still images and movies you shoot can be geotagged using GPS information (such as latitude, longitude, and elevation) from a Bluetooth enabled smartphone (📖164). You can review this information in the GPS information display.
- Latitude, longitude, elevation, and UTC (shooting date and time) are listed from top to bottom.

Before Use

Basic Guide

Advanced Guide

Camera Basics

Auto Mode / Hybrid Auto Mode

Other Shooting Modes

P Mode

Tv, Av, M, and C Mode

Playback Mode

Wireless Features

Setting Menu

Accessories

Appendix

Index





- [---] is shown instead of numerical values for items not available on your smartphone or items not recorded correctly.



- An RGB histogram can also be shown at the top of information displays 2 – 5. Choose one of the information display options from 2 to 5 in [Playback information display] on tab [6], press the [INFO] button, choose [RGB], and then press the [OK] button. Note that information display 3 will show a brightness histogram on the bottom of the screen.
- The brightness histogram can also be accessed while shooting (104, 204).
- UTC: Coordinated Universal Time, essentially the same as Greenwich Mean Time
- GPS information display is not available for images that lack this information.



- You can also switch between the RGB histogram and GPS information display by dragging the lower half of the screen upward or downward in detailed information display.

Viewing Short Movies Created When Shooting Still Images (Digest Movies)

▶ Still Images ▶ Movies

View digest movies recorded automatically in [A] mode (37) on a day of still image shooting as follows.



1 Choose an image.

- Still images shot in [A] mode are labeled with [SET] icon.
- Choose a still image labeled with [SET] and press the [OK] button.



2 Play the digest movie.

- Press the [▲][▼] buttons to choose [A], and then press the [OK] button.
- The movie recorded automatically on the day of still image shooting is played back, from the beginning.



- After a moment, [SET] will no longer be displayed when you are using the camera with information display deactivated (113).

Viewing by Date

Digest movies can be viewed by date.

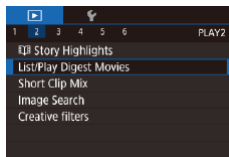

- Press the [MENU] button, choose [List/Play Digest Movies] on the [2] tab, and then touch a date (31).

Before Use

Basic Guide

Advanced Guide

Camera Basics

Auto Mode / Hybrid Auto Mode

Other Shooting Modes

P Mode

Tv, Av, M, and C Mode

Playback Mode

Wireless Features

Setting Menu

Accessories

Appendix

Index



Checking People Detected in Face ID

▶ Still Images ▶ Movies

If you switch the camera to simple information display mode (113), the names of up to five detected people registered in Face ID (145) will be displayed.



- Press the [▼] button several times until simple information display is activated, and then press the [◀][▶] buttons or turn the [Q] dial to choose an image.
- Names will be displayed on detected people.



- If you prefer not to have names displayed on images shot using Face ID, choose MENU (31) > [3] tab > [Face ID Info] > [Name Display] > [Off].

Browsing and Filtering Images

Navigating through Images in an Index

▶ Still Images ▶ Movies

By displaying multiple images in an index, you can quickly find the images you are looking for.

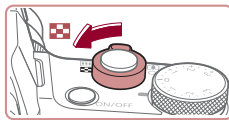

1 Display images in an index.

- Move the zoom lever toward [] to display images in an index. Moving the lever again will increase the number of images shown.
- To display fewer images, move the zoom lever toward [Q]. Fewer images are shown each time you move the lever.



2 Choose an image.

- Turn the [Q] dial to scroll through the images.
- Press the [▲][▼][◀][▶] buttons to choose an image.
- An orange frame is displayed around the selected image.
- Press the [S] button to view the selected image in single-image display.



- To deactivate the 3D display effect (shown if you hold down the [▲][▼] buttons or turn the [Q] dial rapidly), choose MENU (31) > [5] tab > [Index Effect] > [Off].

Before Use

Basic Guide

Advanced Guide

Camera Basics

Auto Mode /
Hybrid Auto Mode

Other Shooting Modes

P Mode

Tv, Av, M, and C Mode

Playback Mode

Wireless Features

Setting Menu

Accessories

Appendix

Index



Touch-Screen Operations



- Pinch in to switch from single-image display to index display.
- To view more thumbnails per screen, pinch in again.
- Drag up or down on the screen to scroll through displayed images.
- To view fewer thumbnails per screen, spread your fingers apart.
- Touch an image to choose it, and touch it again to view it in single-image display.

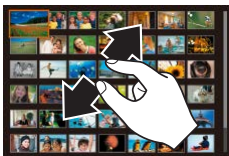

Finding Images Matching Specified Conditions

► Still Images ► Movies

Find desired images quickly on a memory card full of images by filtering image display according to your specified conditions. You can also protect (📖 121) or delete (📖 123) these images all at once.

★ Favorites	Displays images tagged as favorites (📖 126).
📅 Shot Date	Displays the images shot on a specific date.
👤 People	Displays images with detected faces.
📷 Still image/Movie	Displays still images, movies, or movies shot in [📷] mode (📖 37).
👤 Name	Displays images of a registered person (📖 45).

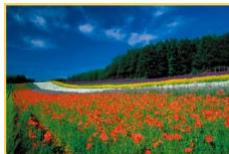
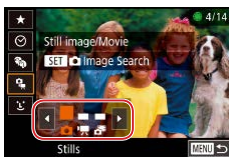

1 Choose the first condition.

- In single-image display, press the [📷] button, choose [🔍] in the menu, and choose a condition.
- When [★] or [👤] is selected, you can view only images matching this condition by pressing the [◀][▶] buttons or turning the [🔍] dial. To perform an action for all of these images together, press the [📷] button and go to step 3.

2 Choose the second condition and view the filtered images.

- When you have selected [🔍] or [👤] as the first condition, choose the second by pressing the [◀][▶] buttons, and then turn the [🔍] dial to view only matching images.
- To switch to filtered image display, press the [📷] button and go to step 3.
- When you have selected [📷] as the first condition, press the [📷] button, and press the [▲][▼][◀][▶] buttons on the next screen to choose a person.

3 View the filtered images.

- Images matching your conditions are displayed in yellow frames. To view only these images, press the [◀][▶] buttons, or turn the [🔍] dial.
- To cancel filtered display, press the [📷] button, choose [🔍] in the menu, and then press the [📷] button again.



- When the camera has found no corresponding images for some conditions, those conditions will not be available.

Before Use

Basic Guide

Advanced Guide

Camera Basics

Auto Mode / Hybrid Auto Mode

Other Shooting Modes

P Mode

Tv, Av, M, and C Mode

Playback Mode

Wireless Features

Setting Menu

Accessories

Appendix

Index





- To show or hide information, press the [▼] button in step 3.
- Options for viewing the images found (in step 3) include “Navigating through Images in an Index” (115), “Magnifying Images” (120), and “Viewing Slideshows” (121). You can also apply image operations to all images found, by choosing [Protect All Images in Search] in “Protecting Images” (121) or [Select All Images in Search] in “Erasing Multiple Images at Once” (124), “Adding Images to the Print List (DPOF)” (194), or “Adding Images to a Photobook” (197).
- If you edit images and save them as new images (128 – 135), a message is displayed, and the images that were found are no longer shown.



- You can also choose conditions by touching the screens in steps 1 and 2.
- After choosing conditions, you can view images matching your conditions by touching a condition again.

Using the Front Dial to Jump between Images

► Still Images ► Movies

Use the front dial to find and jump between desired images quickly by filtering image display according to your specified conditions.

Jump to Favorites	Displays images tagged as favorites (126).
Jump Shot Date	Jumps to the first image in each group of images that were shot on the same date.
Single image	Jumps by 1 image at a time.
Jump 10 Images	Jumps by 10 images at a time.
Jump 100 Images	Jumps by 100 images at a time.



1 Choose a condition.

- Choose a condition (or jump method) in single-image display by turning the dial and immediately pressing the [▲][▼] buttons.

2 View images matching your specified condition, or jump by the specified amount.

- Turn the dial to view only images matching the condition or jump by the specified number of images forward or back.

Touch-Screen Operations

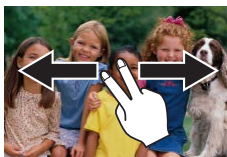

- You can also jump to the previous or next image according to your jump method chosen in step 1 of “Using the Front Dial to Jump between Images” (117) by dragging left or right with two fingers.

Before Use

Basic Guide

Advanced Guide

Camera Basics

Auto Mode / Hybrid Auto Mode

Other Shooting Modes

P Mode

Tv, Av, M, and C Mode

Playback Mode

Wireless Features

Setting Menu

Accessories

Appendix

Index



Viewing Individual Images in a Group

▶ Still Images ▶ Movies

Individual still images saved in [S] mode (168) are grouped, so that only the first image is displayed, but you can also view the images individually.



1 Choose a grouped image.

- Press the [◀][▶] buttons or turn the [DISP] dial to choose an image labeled with [SET] [▶].

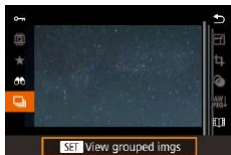

2 Choose [▶].

- Press the [DISP] button, and then choose [▶] in the menu (30).



3 View images in the group individually.

- Pressing the [◀][▶] buttons or turning the [DISP] dial will display only images in the group.
- To cancel group playback, press the [DISP] button, choose [▶] in the menu, and press the [DISP] button again (30).



- During group playback (step 3), you can browse through images quickly “Navigating through Images in an Index” (115) and magnify them “Magnifying Images” (120). You can apply your actions to all images in the group at once by choosing [Protect All Images in Group] in “Protecting Images” (121), [All Images in Group] in “Erasing Multiple Images at Once” (124), [Select All in Group] in “Adding Images to the Print List (DPOF)” (194), or [Select All Images] in “Adding Images to a Photobook” (197).
- To ungroup images so that they are displayed only as single still images, choose MENU (31) > [▶5] tab > [Group Images] > [Off] (31). However, grouped images cannot be ungrouped during individual playback.

Before Use

Basic Guide

Advanced Guide

Camera Basics

Auto Mode /
Hybrid Auto Mode

Other Shooting Modes

P Mode

Tv, Av, M, and C Mode

Playback Mode

Wireless Features

Setting Menu

Accessories

Appendix

Index



Editing Face ID Information

If you notice that a name is incorrect during playback, you can change it or erase it.

However, you cannot add names for people who are not detected by Face ID (names are not displayed), and for people whose names have been erased.

Changing Names

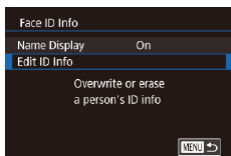

1 Access the setting screen.

- Press the [MENU] button and choose [Face ID Info] on the [▶]3 tab (📖31).
- Press the [▲][▼] buttons or turn the [🌀] dial to choose [Edit ID Info], and then press the [📏] button.



2 Choose an image.

- Following the procedure in “Checking People Detected in Face ID” (📖115), choose an image and press the [📏] button.
- An orange frame is displayed around the selected face. When multiple names are displayed in an image, press the [◀][▶] buttons or turn the [🌀] dial to choose the name to change, and then press the [📏] button.

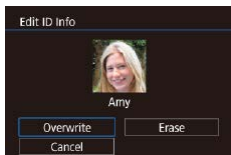

3 Choose the editing option.

- Press the [▲][▼][◀][▶] buttons or turn the [🌀] dial to choose [Overwrite], and then press the [📏] button.

4 Choose the name of the person to overwrite with.

- Follow step 2 in “Overwriting and Adding Face Information” (📖48) to choose the name of the person you want to overwrite with.



- You can also access the [Edit ID Info] screen by touching an image on the screen in step 2, touching [SET] to display the orange frame, and then touching the face to overwrite its name.
- You can also choose editing options by touching them in step 3.

Erasing Names

- On the screen displayed in step 3 in “Changing Names” (📖119), choose [Erase] and press the [📏] button.
- After [Erase?] is displayed, press the [◀][▶] buttons or turn the [🌀] dial to choose [OK], and then press the [📏] button.

Before Use

Basic Guide

Advanced Guide

Camera Basics

Auto Mode / Hybrid Auto Mode

Other Shooting Modes

P Mode

Tv, Av, M, and C Mode

Playback Mode

Wireless Features

Setting Menu

Accessories

Appendix

Index



Image Viewing Options

Magnifying Images

▶ Still Images ▶ Movies

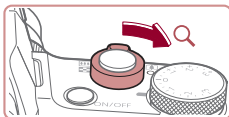

(1)

1 Magnify an image.

- Moving the zoom lever toward [Q] will zoom in and magnify the image. You can magnify images up to about 10x by continuing to hold the zoom lever.
- The approximate position of the displayed area (1) is shown for reference.
- To zoom out, move the zoom lever toward [R]. You can return to single-image display by continuing to hold it.

2 Move the display position and switch images as needed.

- To move the display position, press the [▲][▼][◀][▶] buttons.
- To switch to other images while zoomed, turn the [DISP.] dial.



- You can return to single-image display from magnified display by pressing the [MENU] button.
- You can check the focus when [SET] is displayed by pressing the [DISP.] button to show the position in focus (Focus Check). When multiple positions are in focus, press the [DISP.] button repeatedly to switch to other positions.

Touch-Screen Operations



- Spread your fingers apart (pinch out) to zoom in.
- You can magnify images up to about 10x by repeating this action.
- To move the display position, drag across the screen.
- Pinch in to zoom out.
- Touch [MENU] to restore single-image display.

Double-Touch Magnification



- Quickly touch the screen twice to magnify the image about 3x.
- To return to single-image display from magnified display, quickly touch the screen twice.

Before Use

Basic Guide

Advanced Guide

Camera Basics

Auto Mode / Hybrid Auto Mode

Other Shooting Modes

P Mode

Tv, Av, M, and C Mode

Playback Mode

Wireless Features

Setting Menu

Accessories

Appendix

Index



Viewing Slideshows

▶ Still Images ▶ Movies

Automatically play back images from a memory card as follows.

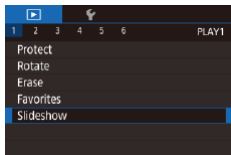

- Press the [MENU] button, and then choose [Slideshow] on the [▶] 1 tab (📖31).
- Press the [▲][▼] buttons or turn the [DISP] dial to choose [Start], and then press the [DISP] button.
- The slideshow will start after [Loading image] is displayed for a few seconds.
- Press the [MENU] button to stop the slideshow.



- The camera's power-saving functions (📖27) are deactivated during slideshows.



- To pause or resume slideshows, press the [DISP] button.
- You can switch to other images during playback by pressing the [◀][▶] buttons or turning the [DISP] dial. For fast-forward or fast-rewind, hold the [◀][▶] buttons down.
- You can configure slideshow repetition, display time per image, and the transition between images on the screen accessed by choosing [Set up] and pressing the [DISP] button (📖31).



- You can also stop slideshows by touching the screen.

Protecting Images

▶ Still Images ▶ Movies

Protect important images to prevent accidental erasure (📖123).



- Press the [DISP] button, choose [Protect] in the menu, and then choose [On] (either press the [◀][▶] buttons or turn the [DISP] dial). [On] is displayed.
- To cancel protection, choose [OFF]. [On] is no longer displayed.



- Protected images on a memory card will be erased if you format the card (📖171).



- Protected images cannot be erased using the camera's erasure function. To erase them this way, first cancel protection.

Using the Menu

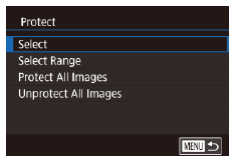
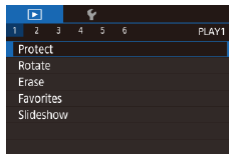

1 Access the setting screen.

- Press the [MENU] button and choose [Protect] on the [▶] 1 tab (📖31).

2 Choose a selection method.

- Choose an option as desired (📖31).
- To return to the menu screen, press the [MENU] button.

Before Use

Basic Guide

Advanced Guide

Camera Basics

Auto Mode / Hybrid Auto Mode

Other Shooting Modes

P Mode

Tv, Av, M, and C Mode

Playback Mode

Wireless Features

Setting Menu

Accessories

Appendix

Index









Choosing Images Individually

1 Choose [Select].





- Following the procedure in “Using the Menu” (121), choose [Select] and press the  button.



2 Choose an image.

- Press the   buttons or turn the  dial to choose an image, and then press the  button.  is displayed.
- To cancel selection, press the  button again.  is no longer displayed.
- Repeat this process to specify other images.

3 Protect the image.

- Press the **[MENU]** button. A confirmation message is displayed.
- Press the   buttons or turn the  dial to choose **[OK]**, and then press the  button.

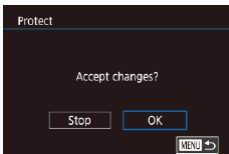

- Images will not be protected if you switch to Shooting mode or turn the camera off before finishing the setup process in step 3.



- You can also select or clear images by touching the screen in step 2, and you can access the confirmation screen by touching **[MENU]**.
- You can also protect images by touching **[OK]** on the screen in step 3.

Selecting a Range

1 Choose [Select Range].



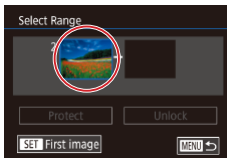

- Following the procedure in “Using the Menu” (121), choose [Select Range] and press the  button.





2 Choose a starting image.

- Press the  button.





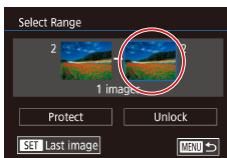

- Press the   buttons or turn the  dial to choose an image, and then press the  button.

3 Choose an ending image.

- Press the  button to choose [Last image], and then press the  button.



- Press the   buttons or turn the  dial to choose an image, and then press the  button.

- Images before the first image cannot be selected as the last image.



Before Use

Basic Guide

Advanced Guide

Camera Basics

Auto Mode /
Hybrid Auto Mode

Other Shooting Modes

P Mode

Tv, Av, M, and C Mode

Playback Mode

Wireless Features

Setting Menu

Accessories

Appendix

Index



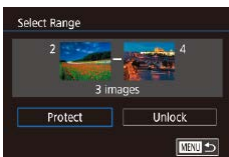

4 Protect the images.

- Press the [▼] button to choose [Protect], and then press the [Ⓜ] button.



- To cancel protection for groups of images, choose [Unlock] in step 4.



- You can also display the screen for choosing the first or last image by touching an image on the top screen in steps 2 or 3.
- You can also protect images by touching [Protect] on the screen in step 4.

Protecting All Images at Once

1 Choose [Protect All Images].

- Following the procedure in “Using the Menu” (121), choose [Protect All Images] and press the [Ⓜ] button.

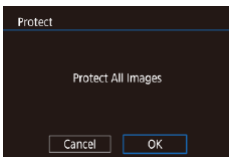

2 Protect the images.

- Press the [◀][▶] buttons or turn the [⦿] dial to choose [OK], and then press the [Ⓜ] button.

Clearing All Protection at Once

You can clear protection from all images at once. To clear protection, choose [Unprotect All Images] in step 1 of “Protecting All Images at Once”, and then complete step 2.

Erasing Images

▶ Still Images ▶ Movies

You can choose and erase unneeded images one by one. Be careful when erasing images, because they cannot be recovered. However, protected images (121) cannot be erased.

1 Choose an image to erase.

- Press the [◀][▶] buttons or turn the [⦿] dial to choose an image.

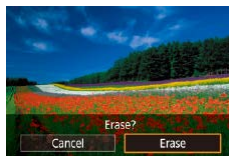

2 Erase the image.

- Press the [▲] button.
- After [Erase?] is displayed, press the [◀][▶] buttons or turn the [⦿] dial to choose [Erase], and then press the [Ⓜ] button.
- The current image is now erased.
- To cancel erasure, press the [◀][▶] buttons or turn the [⦿] dial to choose [Cancel], and then press the [Ⓜ] button.



- For images captured in both RAW and JPEG format, pressing the [▲] button while the image is displayed gives you the option of choosing [Erase RAW], [Erase JPEG], or [Erase RAW+JPEG].



- You can also erase the current image by touching [Erase] on the screen in step 2.
- Images can also be erased by using Touch Actions (127).

Before Use

Basic Guide

Advanced Guide

Camera Basics

Auto Mode / Hybrid Auto Mode

Other Shooting Modes

P Mode

Tv, Av, M, and C Mode

Playback Mode

Wireless Features

Setting Menu

Accessories

Appendix

Index



Erasing Multiple Images at Once

You can choose multiple images to erase at once. Be careful when erasing images, because they cannot be recovered. However, protected images (📖121) cannot be erased.

Choosing a Selection Method

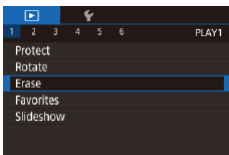

1 Access the setting screen.

- Press the [MENU] button, and then choose [Erase] on the [1] tab (📖31).

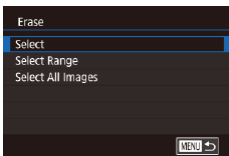

2 Choose a selection method.

- Press the [▲][▼] buttons or turn the [DIAL] dial to choose a selection method, and then press the [SET] button.
- To return to the menu screen, press the [MENU] button.

Choosing Images Individually

1 Choose [Select].

- Following the procedure in “Choosing a Selection Method” (📖124), choose [Select] and press the [SET] button.



2 Choose an image.

- Once you choose an image following step 2 in “Choosing Images Individually” (📖122), [✓] is displayed.
- To cancel selection, press the [DISP] button again. [✓] is no longer displayed.
- Repeat this process to specify other images.

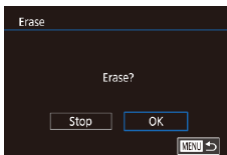

3 Erase the images.

- Press the [MENU] button. A confirmation message is displayed.
- Press the [◀][▶] buttons or turn the [DIAL] dial to choose [OK], and then press the [SET] button.



- Choosing an image captured in both RAW and JPEG format will erase both versions.

Before Use

Basic Guide

Advanced Guide

Camera Basics

Auto Mode /
Hybrid Auto Mode

Other Shooting Modes

P Mode

Tv, Av, M, and C Mode

Playback Mode

Wireless Features

Setting Menu

Accessories

Appendix

Index



Selecting a Range

1 Choose [Select Range].

- Following the procedure in “Choosing a Selection Method” (124), choose [Select Range] and press the  button.

2 Choose images.

- Follow steps 2 – 3 in “Selecting a Range” (122) to specify images.

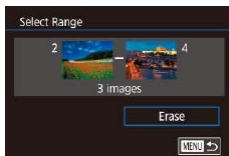

3 Erase the images.



- Press the  button to choose [Erase], and then press the  button.

Specifying All Images at Once

1 Choose [Select All Images].

- Following the procedure in “Choosing a Selection Method” (124), choose [Select All Images] and press the  button.

2 Erase the images.

- Press the   buttons or turn the  dial to choose [OK], and then press the  button.

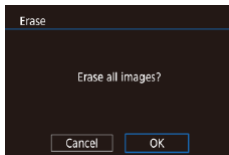

Rotating Images

▶ Still Images ▶ Movies

Change the orientation of images and save them as follows.

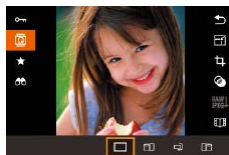

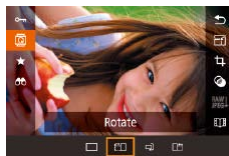

1 Choose [Q].

- Press the  button, and then choose  in the menu (130).



2 Rotate the image.

- Press the  or  button, depending on the desired direction. Each time you press the button, the image is rotated 90°. Press the  button to complete the setting.



- Rotation is not possible when [Auto Rotate] is set to [Off] (126).

Using the Menu

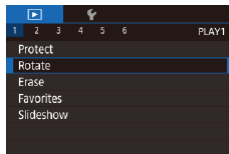

1 Choose [Rotate].

- Press the  button and choose [Rotate] on the  tab (131).

Before Use

Basic Guide

Advanced Guide

Camera Basics

Auto Mode /
Hybrid Auto Mode

Other Shooting Modes

P Mode

Tv, Av, M, and C Mode

Playback Mode

Wireless Features

Setting Menu

Accessories

Appendix

Index



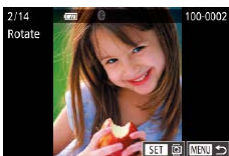

2 Rotate the image.

- Press the [◀][▶] buttons or turn the [DISP] dial to choose an image.
- The image is rotated 90° each time you press the [DISP] button.
- To return to the menu screen, press the [MENU] button.



- On the screen in step 2, you can also touch [SET] to rotate images or touch [MENU] to return to the menu screen.

Deactivating Auto Rotation

Follow these steps to deactivate automatic image rotation, which rotates images based on the current camera orientation.

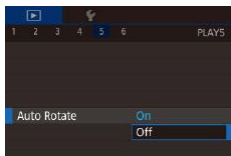

- Press the [MENU] button, choose [Auto Rotate] on the [▶]5 tab, and then choose [Off] (131).



- Images cannot be rotated (125) when you set [Auto Rotate] to [Off]. Additionally, images already rotated will be displayed in the original orientation.

Tagging Images as Favorites

▶ Still Images ▶ Movies

You can organize images by tagging them as favorites. By choosing a category in filtered playback, you can restrict the following operations to all of those images.

- “Playback” (111), “Viewing Slideshows” (121), “Protecting Images” (121), “Erasing Images” (123), “Adding Images to the Print List (DPOF)” (194), “Adding Images to a Photobook” (197)

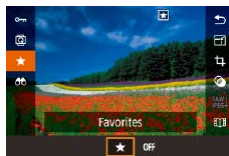

- Press the [DISP] button, and then choose [★] in the menu (30).
- To untag the image, repeat this process and choose [OFF], and then press the [DISP] button.

Using the Menu

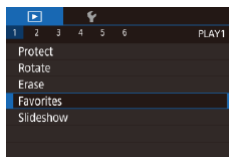

1 Choose [Favorites].

- Press the [MENU] button and choose [Favorites] on the [▶]1 tab (31).

2 Choose an image.

- Press the [◀][▶] buttons or turn the [DISP] dial to choose an image, and then press the [DISP] button. [★] is displayed.
- To untag the image, press the [DISP] button again. [★] is no longer displayed.
- Repeat this process to choose additional images.

Before Use

Basic Guide

Advanced Guide

Camera Basics

Auto Mode / Hybrid Auto Mode

Other Shooting Modes

P Mode

Tv, Av, M, and C Mode

Playback Mode

Wireless Features

Setting Menu

Accessories

Appendix

Index



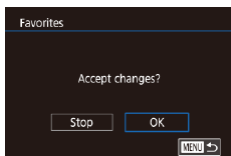

3 Finish the setup process.

- Press the [MENU] button. A confirmation message is displayed.
- Press the [◀][▶] buttons or turn the [DISP] dial to choose [OK], and then press the [MENU] button.



- Images will not be tagged as favorites if you switch to Shooting mode or turn the camera off before finishing the setup process in step 3.



- Tagging images as favorites makes it easier to add them when creating albums (📖136).



- You can also select or clear current images by touching the screen in step 2.
- Images can also be tagged as favorites by using Touch Actions (📖127).

Convenient Control: Touch Actions

▶ Still Images ▶ Movies

You can quickly and easily activate functions that you have assigned to four touch gestures (Touch Actions), in single-image display.

Using Touch Actions Functions

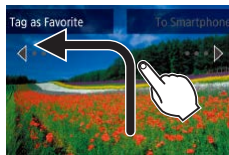

- Drag across the screen as shown.
- The function assigned to [←] is now activated.

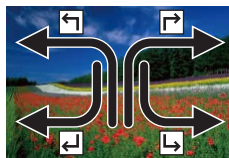

- Similarly, you can also activate functions assigned to [→], [←], and [↵] by dragging across the screen.
- Customize functions assigned to Touch Actions as desired.

Changing Touch Actions Functions

Simplify your preferred camera operations by reassigning dragging patterns to them as desired.

1 Access the setting screen.

- Press the [MENU] button, and then choose [Set Touch Actions] on the [▶] 6 tab (📖31).

Before Use

Basic Guide

Advanced Guide

Camera Basics

Auto Mode /
Hybrid Auto Mode

Other Shooting Modes

P Mode

Tv, Av, M, and C Mode

Playback Mode

Wireless Features

Setting Menu

Accessories

Appendix

Index



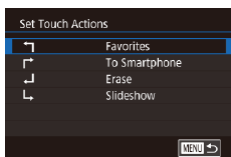

2 Assign a function to a Touch Action.

- Press the [▲][▼] buttons or turn the [DISP] dial to choose a dragging pattern, and then press the [SET] button.
- Press the [▲][▼] buttons or turn the [DISP] dial to choose a function to assign.

Assignable Functions

Slideshow	Start a slideshow.
Erase	Erase an image.
Protect	Protect an image or cancel protection.
Rotate	Rotate an image.
Favorites	Tag images as favorites, or untag the image.
Next Favorite	Switch to displaying the next image tagged as a favorite.
Previous Favorite	Switch to displaying the previous image tagged as a favorite.
Next Date	Switch to displaying the first image with the next shooting date.
Previous Date	Switch to displaying the first image with the previous shooting date.
To Camera	Access the Wi-Fi connection screen. For Wi-Fi details, see “Wireless Features” (141).
To Smartphone	
To Computer	
To Printer	
To Web Service	

Editing Still Images



- Image editing (128 – 131) is only available when the memory card has sufficient free space.



- You can access editing screens for various functions by touching an image after choosing the function in the menu.
- When [MENU] is shown on an editing screen, you can touch [MENU] instead of pressing the [MENU] button, if you prefer.
- When [SET] is shown on an editing screen, you can touch [SET] instead of pressing the [SET] button, if you prefer.

Resizing Images

▶ Still Images ▶ Movies

Save a copy of images at a lower number of recording pixels.



1 Choose an image size.

- Press the [SET] button, choose [] in the menu, and choose an image size (30).
- Press the [SET] button.

2 Save the new image.

- After [Save new image?] is displayed, press the [◀][▶] buttons or turn the [DISP] dial to choose [OK], and then press the [SET] button.
- The image is now saved as a new file.

Before Use

Basic Guide

Advanced Guide

Camera Basics

Auto Mode /
Hybrid Auto Mode

Other Shooting Modes

P Mode

Tv, Av, M, and C Mode

Playback Mode

Wireless Features

Setting Menu

Accessories

Appendix

Index





3 Review the new image.

- Press the [◀][▶] buttons or turn the [DISP] dial to choose [Processed img.], and then press the [DISP] button.
- The saved image is now displayed.



- Editing is not possible for images shot at a recording pixel setting of [S2].
- RAW images cannot be edited.



- Images cannot be resized to a higher number of recording pixels.



- You can also view saved images by touching [Processed img.] on the screen in step 3.

Using the Menu

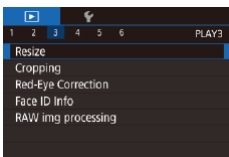

1 Choose [Resize].

- Press the [MENU] button and choose [Resize] on the [▶]3 tab (128).

2 Choose an image.

- Press the [◀][▶] buttons or turn the [DISP] dial to choose an image, and then press the [DISP] button.

3 Choose an image size.

- Press the [◀][▶] buttons or turn the [DISP] dial to choose the size, and then press the [DISP] button.

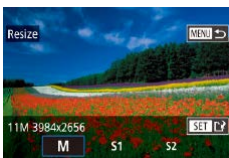

4 Save as a new image and review.

- Follow step 2 in “Resizing Images” (128).
- Press the [MENU] button and follow step 3 in “Resizing Images” (128).

Cropping

▶ Still Images ▶ Movies

You can specify a portion of an image to save as a separate image file.

1 Access the setting screen.

- Press the [DISP] button, choose [C] in the menu, and then press the [DISP] button (130).

2 Resize, move, and adjust the aspect ratio of the cropping frame.

- To resize the frame, move the zoom lever.
- To move the frame, press the [▲][▼][◀][▶] buttons.
- To change the frame orientation, turn the [DISP] dial to choose [C], and then press the [DISP] button.
- To change the frame aspect ratio, turn the [DISP] dial to choose [A]. To switch between aspect ratios ([3:2], [16:9], [4:3], and [1:1]), press the [DISP] button repeatedly.



Before Use

Basic Guide

Advanced Guide

Camera Basics

Auto Mode / Hybrid Auto Mode

Other Shooting Modes

P Mode

Tv, Av, M, and C Mode

Playback Mode

Wireless Features

Setting Menu

Accessories

Appendix

Index



3 Preview the cropped image.

- Turn the [DISP.] dial to choose [C].
- To switch display between the cropped image and the cropping frame, press the [DISP.] button repeatedly.

4 Save as a new image and review.

- Turn the [DISP.] dial to choose [L], and then press the [DISP.] button.
- Follow steps 2 – 3 in “Resizing Images” (p. 128).



- RAW images cannot be edited.
- Cropped images cannot be cropped again.
- Cropped images cannot be resized or have Creative filters applied.



- Cropped images will have a lower number of recording pixels than uncropped images.
- While previewing the cropped image in step 3, you can resize, move, and adjust the aspect ratio of the cropping frame.
- Operations in step 2 are also possible by pressing the [MENU] button, choosing [3] tab > [Cropping], pressing the [DISP.] button, choosing an image, and pressing the [DISP.] button again.
- If you crop still images shot using Face ID (p. 45), only the names of the people left in the cropped image will remain.



- You can also move the cropping frame in step 2 by dragging it. You can also resize frames by pinching in or out (p. 120) on the screen.
- Operations are also possible by touching [C], [L], [R], and [A] on the top of the screen in step 2.

Applying Filter Effects

Apply effects equivalent to shooting in [L], [M], [S], [K], [A], [C], and [P] modes to images and save them as separate images.

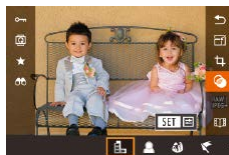

1 Choose an effect.

- Press the [DISP.] button, choose [C] in the menu, and then choose the effect (p. 30).
- Press the [DISP.] button.

2 Adjust the effect as needed.

- [L]: Press the [◀][▶] buttons to adjust contrast.
- [M]: Press the [◀][▶] buttons to adjust defocusing.
- [S] or [K]: Touch or drag the bar on the bottom of the screen to adjust the level of the effect.
- [A]: Press the [◀][▶] buttons to adjust color saturation.
- [C]: Press the [◀][▶] buttons to adjust color tone.
- [P]: Move the zoom lever to resize the frame, and turn the [DISP.] dial to move it.

3 Save as a new image and review.

- Press the [DISP.] button.
- Follow steps 2 – 3 in “Resizing Images” (p. 128).

Before Use

Basic Guide

Advanced Guide

Camera Basics

Auto Mode /
Hybrid Auto Mode

Other Shooting Modes

P Mode

Tv, Av, M, and C Mode

Playback Mode

Wireless Features

Setting Menu

Accessories

Appendix

Index





- The same operations are available by pressing the [MENU] button and choosing [D]2 tab > [Creative filters], choosing an image, and pressing the [SET] button.
- [SET]: To switch the orientation of the frame to vertical, press the [◀][▶] buttons on the screen in step 2. To move the frame, press the [◀][▶] buttons again. To return the frame to horizontal orientation, press the [▲][▼] buttons.



- You can also adjust the effect by touching or dragging the bar on the bottom of the screen in step 2. For [SET], you can also move the frame by touching or dragging across the screen.

Correcting Red-Eye

▶ Still Images ▶ Movies

Automatically corrects images affected by red-eye. You can save the corrected image as a separate file.

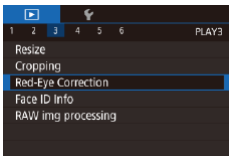

1 Choose [Red-Eye Correction].

- Press the [MENU] button, and then choose [Red-Eye Correction] on the [D]3 tab (📖31).

2 Choose an image.

- Press the [◀][▶] buttons or turn the [DISK] dial to choose an image.

3 Correct the image.

- Press the [SET] button.
- Red-eye detected by the camera is now corrected, and frames are displayed around corrected image areas.
- Enlarge or reduce images as needed. Follow the steps in “Magnifying Images” (📖120).

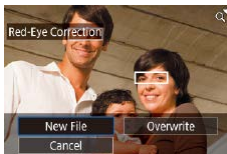

4 Save as a new image and review.

- Press the [▲][▼][◀][▶] buttons or turn the [DISK] dial to choose [New File], and then press the [SET] button.
- The image is now saved as a new file.
- Press the [MENU] button and follow step 3 in “Resizing Images” (📖128).



- Some images may not be corrected accurately.
- To overwrite the original image with the corrected image, choose [Overwrite] in step 4. In this case, the original image will be erased.
- Protected images cannot be overwritten.
- RAW images cannot be edited this way.
- Red-eye correction can be applied to JPEG images also captured in RAW format, but the original image cannot be overwritten.



- You can also save images by touching [New File] or [Overwrite] on the screen in step 4.

Before Use

Basic Guide

Advanced Guide

Camera Basics

Auto Mode /
Hybrid Auto Mode

Other Shooting Modes

P Mode

Tv, Av, M, and C Mode

Playback Mode

Wireless Features

Setting Menu

Accessories

Appendix

Index



Processing RAW Images with the Camera

► Still Images ► Movies

Process images captured in RAW format on the camera. The original RAW image is retained, and a copy is saved as a JPEG.

1 Choose a RAW image.

- Press the [◀][▶] buttons or turn the [DISP.] dial to choose a RAW image.



2 Access the setting screen.

- Press the [MENU] button, and choose [RAW/JPEG] in the menu. Choose the desired option (either press the [◀][▶] buttons or turn the [DISP.] dial).
- When choosing [RAW], go to step 5.



3 Set the processing conditions.

- If you have chosen [RAW], press the [DISP.] button, press the [▲][▼][◀][▶] buttons to choose an option, and then press the [DISP.] button.



4 Configure advanced settings.

- Choose an effect (either press the [◀][▶] buttons or turn the [DISP.] dial), and then press the [DISP.] button to return to the screen in step 3.

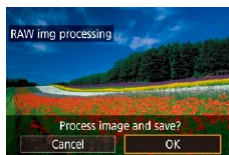

Brightness adjustment	Adjust brightness.
White balance	Choose a white balance.
Picture Style	Choose a Picture Style.
Auto Lighting Optimizer	Set Auto Lighting Optimizer details.
High ISO speed NR	Set noise reduction details.
Image quality	Set the image quality level of the resulting JPEG image.



- You can also choose an effect for a selected processing condition on the screen in step 3 by turning the [DISP.] dial.
- For magnified display on the screen in step 3, move the zoom lever toward [Q].
- To restore the original settings, on the screen in step 3, press the [RESET] button, choose [OK] (either press the [◀][▶] buttons or turn the [DISP.] dial), and then press the [DISP.] button.
- You can configure advanced settings for functions labeled with [INFO] on the screen in step 4 by pressing the [▼] button.
- To compare the current image to the original image before saving in step 5, press the [X] button and turn the [DISP.] dial. To return to the setting screen, press the [MENU] button.

5 Save the image.

- If you have chosen [RAW/JPEG], press the [▲][▼][◀][▶] buttons to choose [L1]. Press the [DISP.] button, choose [OK] (either press the [◀][▶] buttons or turn the [DISP.] dial), and then press the [DISP.] button again.
- If you have chosen [RAW], press the [◀][▶] buttons or turn the [DISP.] dial to choose [OK], and then press the [DISP.] button.

Before Use

Basic Guide

Advanced Guide

Camera Basics

Auto Mode / Hybrid Auto Mode

Other Shooting Modes

P Mode

Tv, Av, M, and C Mode

Playback Mode

Wireless Features

Setting Menu

Accessories

Appendix

Index



Using the Menu

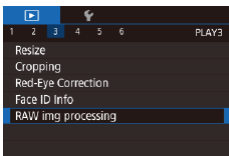

1 Access the setting screen.

- Press the [MENU] button and choose [RAW img processing] on the [▶] 3 tab (📖31).

2 Choose a selection method.

- Choose an option as desired (📖31).
- To return to the menu screen, press the [MENU] button.

Choosing Images Individually



1 Choose [Select].

- Following the procedure in “Using the Menu” (📖133), choose [Select] and press the [⏏] button.

2 Choose an image.

- Once you choose an image following step 2 in “Choosing Images Individually” (📖122), [✓] is displayed.
- To cancel selection, press the [⏏] button again. [✓] is no longer displayed.
- Repeat this process to specify other images.
- Press the [MENU] button to go to the next screen.

3 Process the image.

- Follow steps 2 – 5 in “Processing RAW Images with the Camera” (📖132) to process the image.

Selecting a Range

1 Choose [Select Range].

- Following the procedure in “Using the Menu” (📖133), choose [Select Range] and press the [⏏] button.

2 Choose images.

- Follow steps 2 – 3 in “Selecting a Range” (📖122) to specify images.

3 Process the images.

- Follow steps 2 – 5 in “Processing RAW Images with the Camera” (📖132) to process the images.



- Images produced by in-camera processing will not match those processed with Digital Photo Professional exactly.



- Up to 500 images can be selected at one time.

Before Use

Basic Guide

Advanced Guide

Camera Basics

Auto Mode /
Hybrid Auto Mode

Other Shooting Modes

P Mode

Tv, Av, M, and C Mode

Playback Mode

Wireless Features

Setting Menu

Accessories

Appendix

Index



Editing Movies

▶ Still Images ▶ Movies

You can remove unneeded portions from the beginning and end of movies.

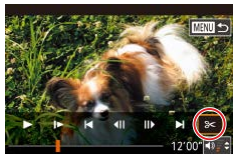

1 Choose [OK].

- Following steps 1 – 5 in “Playback” (111), choose [OK] and press the [OK] button.
- The movie editing panel and editing bar are now displayed.

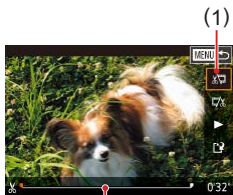

2 Specify portions to cut.

- (1) is the movie editing panel, and (2) is the editing bar.
- Press the [▲][▼] buttons to choose [L7] or [R7].
- To specify a portion to cut (indicated by [L7]), press the [◀][▶] buttons or turn the [DISC] dial to move the orange [L] or [R] icon. Cut the beginning of the movie (from [L7]) by choosing [L7], and cut the end of the movie by choosing [R7].
- If you move [L] or [R] to a position other than a [L7] mark, in [L7] the portion before the nearest [L7] mark on the left will be cut, while in [R7] the portion after the nearest [L7] mark on the right will be cut.

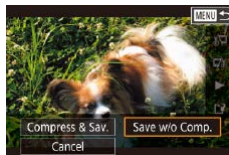
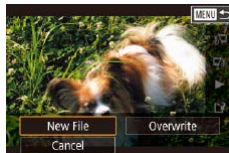

3 Review the edited movie.

- Press the [▲][▼] buttons to choose [▶], and then press the [DISC] button. The edited movie is now played.
- To edit the movie again, repeat step 2.
- To cancel editing, press the [MENU] button, choose [OK] (either press the [◀][▶] buttons or turn the [DISC] dial), and then press the [DISC] button.

4 Save the edited movie.

- Press the [▲][▼] buttons to choose [L7], and then press the [DISC] button.
- Press the [▲][▼][◀][▶] buttons or turn the [DISC] dial to choose [New File], and then press the [DISC] button.
- Choose [Save w/o Comp.], and then press the [DISC] button.
- The movie is now saved as a new file.



- To overwrite the original movie with the cut one, choose [Overwrite] in step 4. In this case, the original movie will be erased.
- If the memory card lacks sufficient space, only [Overwrite] will be available.
- Movies may not be saved if the battery pack runs out while saving is in progress.
- When editing movies, you should use a fully charged battery pack.



- You can also edit movies by touching the movie editing panel or editing bar.

Before Use

Basic Guide

Advanced Guide

Camera Basics

Auto Mode / Hybrid Auto Mode

Other Shooting Modes

P Mode

Tv, Av, M, and C Mode

Playback Mode

Wireless Features

Setting Menu

Accessories

Appendix

Index



Reducing File Sizes

Movie file sizes can be reduced by compressing movies as follows.

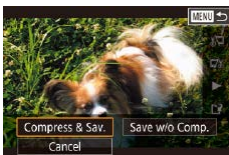

- On the screen in step 2 of “Editing Movies”, choose [L]. Choose [New File], and then press the [MENU] button.
- Choose [Compress & Sav.], and then press the [MENU] button.

Image Quality of Compressed Movies

Before Compression	After Compression
FHD 59.94P, FHD 29.97P	FHD 29.97P
FHD 23.98P	FHD 23.98P
FHD 50.00P, FHD 25.00P	FHD 25.00P



- [VGA 29.97P] and [VGA 25.00P] movies cannot be compressed.
- Edited movies cannot be saved in compressed format when you choose [Overwrite].
- Compressing movies to [FHD 29.97P] or [FHD 25.00P] reduces the file size while maintaining the same image quality.

Erasing Movie Chapters

▶ Still Images ▶ Movies

Individual chapters (clips) (137) recorded in [A] mode can be erased, as needed. Be careful when erasing clips, because they cannot be recovered.



1 Select the clip to erase.

- Follow steps 1 – 2 in “Viewing Short Movies Created When Shooting Still Images (Digest Movies)” (114) to play a short movie, and then press the [MENU] button to access the movie control panel.
- To choose the clip, press the [L][R] buttons or turn the [DIAL] dial to choose [L] or [R], and then press the [MENU] button.

2 Choose [L].

- Press the [L][R] buttons or turn the [DIAL] dial to choose [L], and then press the [MENU] button.
- The selected clip is played back repeatedly.

3 Confirm erasure.

- Press the [L][R] buttons or turn the [DIAL] dial to choose [OK], and then press the [MENU] button.
- The clip is erased, and the short movie is overwritten.

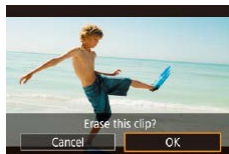

- [L] is not displayed if you select a clip when the camera is connected to a printer.

Before Use

Basic Guide

Advanced Guide

Camera Basics

Auto Mode /
Hybrid Auto Mode

Other Shooting Modes

P Mode

Tv, Av, M, and C Mode

Playback Mode

Wireless Features

Setting Menu

Accessories

Appendix

Index



Viewing Albums (Story Highlights)

▶ Still Images ▶ Movies

You can choose themes such as a date or person's name to create an album of automatically selected images that match the theme. These images are combined into a slideshow that can be saved as a short movie of about 2 – 3 minutes.

Before using this feature, make sure the battery pack is fully charged. Creating albums also requires free space on the memory card. As a guideline, use a memory card with a capacity of 16 GB or higher, and ensure at least 1 GB of free space.

Choosing Themes for Albums

Press the button and choose the Story Highlights icon. The home screen is displayed, and you can choose the theme for the camera to use when selecting album elements. Note that the camera is more likely to add images tagged as favorites (126) to albums.

Date	Creates an album of images shot on the same day. Images are selected from those shot on the same day as the image displayed before you access the home screen.
Person's name	Can be used to create monthly albums of people, such as albums of children as they grow up. Subjects whose Face ID information you registered before shooting may be selected for albums. Images selected are those that have the same subject shot during the same month as the image displayed before you access the home screen.
Event	A good choice for albums of vacations, parties, or other events. Images are selected from those shot during the event before and after the image displayed before you access the home screen.
Custom	Includes images based on your specified images, dates, or people registered in Face ID.

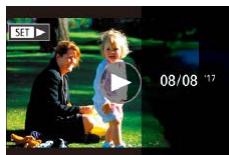
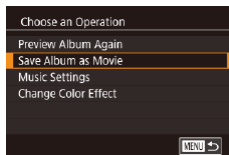
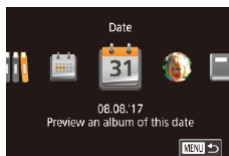
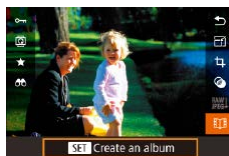

1 Choose an image.

- Choose an image in single-image display.
- Themes available in step 3 will vary depending on image shooting date and Face ID information.

2 Access the home screen.

- Press the button, choose , and then press the button (30).
- After [Busy] is displayed, the home screen is displayed.

3 Preview an album.

- Press the buttons to choose a person or [Date] or [Event] as the album theme, and then press the button.
- After [Loading] is displayed for a few seconds, the album is played.

4 Save the album.

- Press the buttons to choose [Save Album as Movie], and then press the button.
- Once the album is saved, [Saved] is displayed.

5 Play the album (111).

Before Use

Basic Guide

Advanced Guide

Camera Basics

Auto Mode /
Hybrid Auto Mode

Other Shooting Modes

P Mode

Tv, Av, M, and C Mode

Playback Mode

Wireless Features

Setting Menu

Accessories

Appendix

Index





- Albums can include following images captured by the camera.
 - Still images
 - Digest movies (📖37), except compressed movies
 - Short movie clips with a playback time of two seconds or more (📖74), except compressed movies



- Albums cannot be saved unless there is enough space on the memory card.
- You can also access the Story Highlights home screen by choosing MENU (📖31) > [📺] tab > [📖] Story Highlights.
- To jump to the next chapter during the preview, drag left, and to jump to the previous chapter, drag right.
- You can specify the color effect in step 4 by choosing [Change Color Effect] and pressing the [📖] button. To preview how the album looks with your selected effect applied, choose [Preview Album Again] on the screen in step 4 after pressing the [⏪] buttons to choose a color effect and pressing the [📖] button.
- To play saved albums, choose [List of Albums] on the Story Highlights home screen, press the [📖] button, choose a listed album, and press the [📖] button again.

Adding Background Music to Albums

▶ Still Images ▶ Movies

Choose from seven kinds of background music to play during album playback.

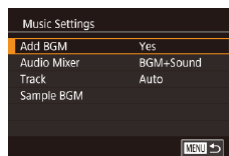
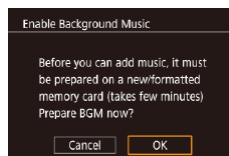

1 Register background music to a memory card.

- Following steps 1 – 4 in “Viewing Albums (Story Highlights)” (📖136), choose [Music Settings] and press the [📖] button.
- The screen at left is displayed when you use a new or recently formatted memory card. Choose [OK] (either press the [⏪] buttons or turn the [📖] dial), press the [📖] button, and wait about four minutes until the seven types of music are registered to the card.
- When using a memory card with music already registered to it, go to step 2.

2 Create the album.

- Follow steps 1 – 3 in “Viewing Albums (Story Highlights)” (📖136) to create an album.

3 Configure background music settings.

- Press the [▲][▼] buttons or turn the [📖] dial to choose the desired item, press the [📖] button, and then press the [▲][▼] buttons or turn the [📖] dial to choose an option (📖31).

Before Use

Basic Guide

Advanced Guide

Camera Basics

Auto Mode / Hybrid Auto Mode

Other Shooting Modes

P Mode

Tv, Av, M, and C Mode

Playback Mode

Wireless Features

Setting Menu

Accessories

Appendix

Index



4 Save the album.

- Follow step 4 in “Viewing Albums (Story Highlights)” (📖 136) to save albums.



- Once albums are saved, background music cannot be added later. Background music in albums cannot be removed or changed.
- Chapters of albums with background music cannot be edited (📖 135).



- If you prefer not to add background music, set [Add BGM] to [No] on the screen in step 3.
- To use only background music instead of movie audio, set [Audio Mixer] to [BGM only] on the screen in step 3.
- To listen to a sample of the background music selected in [Track], choose [Sample BGM] on the screen in step 3 and press the [🔊] button.

Creating Your Own Albums

▶ Still Images ▶ Movies

Create your own albums by choosing desired images.

1 Choose to create a Custom album.

- Following steps 1 – 3 in “Viewing Albums (Story Highlights)” (📖 136), choose [Custom] and press the [🔊] button.

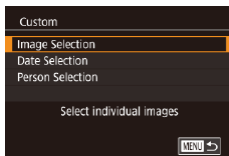

2 Choose a selection method.

- Choose [Image Selection], [Date Selection], or [Person Selection], and then press the [🔊] button.

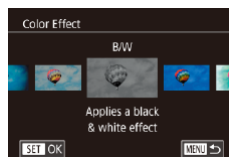
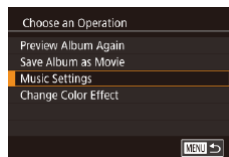

3 Choose album elements.

- Once you select the elements for your album and press the [🔊] button, your selected elements are labeled with [✓].
- Press the [MENU] button after you are finished selecting still images or short clips in [Image Selection], dates in [Date Selection], or people in [Person Selection].
- Press the [◀][▶] buttons or turn the [🔊] dial to choose [Preview], and then press the [🔊] button.

4 Choose background music.

- When the screen at left is displayed, choose [Music Settings]. Add background music as described in “Adding Background Music to Albums” (📖 137), and then press the [MENU] button.

5 Choose a color effect.

- On the screen in step 4, choose [Change Color Effect].
- Press the [◀][▶] buttons to choose a color effect, and then press the [🔊] button.

6 Save the album.

- Follow step 4 in “Viewing Albums (Story Highlights)” (📖 136) to save albums.

Before Use

Basic Guide

Advanced Guide

Camera Basics

Auto Mode /
Hybrid Auto Mode

Other Shooting Modes

P Mode

Tv, Av, M, and C Mode

Playback Mode

Wireless Features

Setting Menu

Accessories

Appendix

Index





- You can specify up to 40 files (or 10 movie files) after choosing [Image Selection]. The second time you create a custom album, [Select images based on previous settings?] is displayed. To use previously selected images as the basis, choose [Yes]. The previous stills or clips are labeled with [✓], and multiple images are displayed.
- Up to 15 dates can be selected if you choose [Date Selection].
- The color effect may not be applied to some images.

Combining Short Clips

▶ Still Images ▶ Movies

Combine short clips to create a longer movie.
Note that movies created this way are not included in Story Highlights albums (📖136).

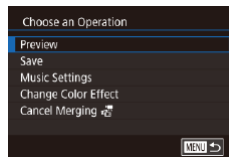
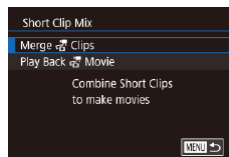

1 Access the editing screen.

- Press the [MENU] button, choose [Short Clip Mix] on the [▶2] tab, and then choose [Merge Clips] (📖31).

2 Specify clips to combine.

- Drag clips on the top of the screen left or right, choose a clip to combine, and press the [⊕] button.
- Your selected clip is displayed on the bottom of the screen.
- To cancel selection, press the [⊕] button again.
- Repeat these steps to specify other clips to combine.
- After you are finished selecting clips, press the [MENU] button.

3 Preview the movie.

- Choose [Preview] and press the [⊕] button.
- After [Loading] is displayed for a few seconds, a preview of the combined clips is played.

Before Use

Basic Guide

Advanced Guide

Camera Basics

Auto Mode / Hybrid Auto Mode

Other Shooting Modes

P Mode

Tv, Av, M, and C Mode

Playback Mode

Wireless Features

Setting Menu

Accessories

Appendix

Index





4 Save the movie.

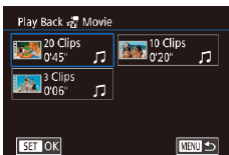







- Choose [Save], and then press the  button.
- Once the album is saved, [Saved] is displayed.



5 Play the movie.

- Choose [Play Back  Movie] on the screen in step 1 to view a list of movies you have created.
- Choose the movie to play and press the  button.



- The next time you combine short clips, [Select images based on previous settings?] is displayed, and you can choose [Yes] to display the editing screen with clips arranged in the order you selected them last time.
- To play the selected clip, move the zoom lever toward  on the screen in step 2.
- To rearrange clips, press the  button on the screen in step 2, select a clip, press the  button, press the   buttons or turn the  dial, and then press the  button again.
- To apply a color effect, choose [Change Color Effect] on the screen in step 3.
- To add background music, choose [Music Settings] on the screen in step 3 ( 137).
- The image quality of movies saved is .
- Use a fully charged battery pack, if possible.

Wireless Features

Send images wirelessly from the camera to a variety of compatible devices, and use the camera with Web services



- Before using wireless features, be sure to read “Precautions for Wireless Features (Wi-Fi, Bluetooth, or Others)” (P.229).

Available Wireless Features

■ Using Wi-Fi Features

You can send and receive images and control the camera remotely by connecting it to these devices and services via Wi-Fi.

- **Smartphones and Tablets**
Send images to smartphones and tablet computers that have Wi-Fi functions. Remote live view shooting is also possible from a smartphone or tablet.
For convenience in this guide, smartphones, tablets, and other compatible devices are collectively referred to as “smartphones”.
- **Computers**
Use software to save camera images to a computer connected via Wi-Fi.
- **Web Services**
Add your account information to the camera for CANON iMAGE GATEWAY online photo service or other Web services to send camera images to the services. Unsent images on the camera can also be sent to a computer or Web service via CANON iMAGE GATEWAY.
- **Printers**
Print images wirelessly on a PictBridge-compatible printer (supporting DPS over IP).
- **Other Cameras**
Send images wirelessly between Wi-Fi-compatible Canon cameras.

■ Using Bluetooth® Features

You can easily pair the camera with a smartphone featuring Bluetooth low energy technology*. You can also shoot, view, or geotag images by using your smartphone as a remote control.

* Hereafter referred to as “Bluetooth”.

Before Use

Basic Guide

Advanced Guide

Camera Basics

Auto Mode /
Hybrid Auto Mode

Other Shooting Modes

P Mode

Tv, Av, M, and C Mode

Playback Mode

Wireless Features

Setting Menu

Accessories

Appendix

Index



Sending Images to a Smartphone

There are several ways to connect the camera to a smartphone and send images.

- **Connect via Bluetooth**
You can easily connect the camera to a Bluetooth enabled smartphone by pairing them. This simplifies transferring images to a smartphone.
- **Connect via NFC** (📖144)
Simply touch an NFC-compatible Android smartphone against the camera to connect the devices.
- **Connect via the Wi-Fi menu** (📖146)
You can connect the camera to a smartphone as you would connect it to a computer or other device. Multiple smartphones can be added.

Before connecting to the camera, you must install the free dedicated Camera Connect app on the smartphone. For details on this application (supported smartphones and included functions), refer to the Canon website.



- Canon Wi-Fi-compatible camera owners who use CameraWindow to connect their camera via Wi-Fi to a smartphone should consider switching to the Camera Connect mobile app.

Sending Images to a Bluetooth Enabled Smartphone

Once you have paired with a smartphone via Bluetooth, simply operate your smartphone to view and save camera images.



1 Install Camera Connect.

- For Android smartphones, find Camera Connect in Google Play and download and install the app.
- For an iPhone or iPad, find Camera Connect in the App Store and download and install the app.

2 Register a nickname.

- Press the power button.
- Press the [MENU] button, choose [Wireless settings] on the [Y4] tab, and then choose [Nickname].
- Press the [F3] button to access the keyboard (📖32), and then enter a nickname.
- To return to [Wireless settings] after pressing the [MENU] button, press the [MENU] button again.

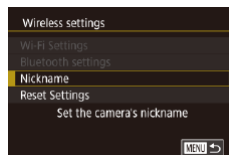

Before Use

Basic Guide

Advanced Guide

Camera Basics

Auto Mode /
Hybrid Auto Mode

Other Shooting Modes

P Mode

Tv, Av, M, and C Mode

Playback Mode

Wireless Features

Setting Menu

Accessories

Appendix

Index



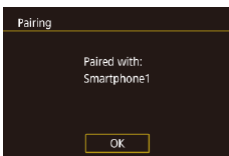
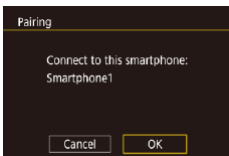
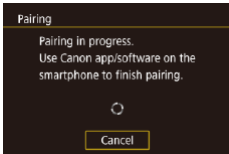
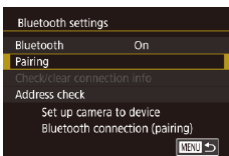

3 Prepare for pairing.

- Choose [Bluetooth settings], press the [▲][▼] buttons or turn the [DISP] dial to choose [Pairing], and then press the [SET] button.
- A screen is displayed indicating that the camera is waiting to connect.

4 Start Camera Connect.

- Activate Bluetooth on the smartphone, and then start Camera Connect on the smartphone.
- After the camera is recognized, a camera selection screen is displayed.

5 Select the camera to connect to.

- Choose the camera nickname.
- Complete the pairing process for the smartphone.

6 Complete pairing.

- Press the [◀][▶] buttons or turn the [DISP] dial to choose [OK] after the confirmation message on the camera, and then press the [SET] button.
- Press the [SET] button when the screen at left is displayed.



7 Transfer images.

- The camera will automatically switch to Wi-Fi if you choose [Images on camera] in Camera Connect.
- On an iPhone or iPad, in the device's Wi-Fi setting menu, choose the SSID (network name) displayed on the camera to establish a connection.
- Use the smartphone to transfer images from the camera to the smartphone.
- To switch to Bluetooth, disable the Wi-Fi connection on the smartphone.



- Battery life may be shorter when you use the camera after pairing, because power is consumed even when the camera is off.
- Before bringing the camera to places where the use of electronic devices is restricted, set [Bluetooth] to [Off], to avoid having the camera ready for Bluetooth communication even when it is off.



- Bluetooth connection status is indicated by one of the following icons.
[Bluetooth icon] Connected, [Bluetooth icon] Disconnected
- You can also use the camera to disable Wi-Fi connection described in step 7.
- To check the information of the smartphone connected via Bluetooth in [Check/clear connection info], choose MENU (31) > [4] tab > [Wireless settings] > [Bluetooth settings]. Choose [Address check] to check the camera's Bluetooth address.

Before Use

Basic Guide

Advanced Guide

Camera Basics

Auto Mode /
Hybrid Auto Mode

Other Shooting Modes

P Mode

Tv, Av, M, and C Mode

Playback Mode

Wireless Features

Setting Menu

Accessories

Appendix

Index



■ Sending Images to an NFC-Compatible Smartphone

Use an Android smartphone's NFC to simplify the process of installing Camera Connect and connecting to the camera. Operation when devices are initially connected via NFC varies depending on the camera mode when the devices are touched together.

- If the camera is off or in Shooting mode when the devices are touched together, you can choose and send images on the image selection screen. Once the devices are connected, you can also use your smartphone for remote live view shooting (164). It's easy to reconnect to recent devices, which are listed in the Wi-Fi menu.
- If the camera is in Playback mode when the devices are touched together, you can choose and send images from the index display shown for image selection.

Follow the instructions in the following section for NFC-initiated connection to a camera that is off or in Shooting mode.

Connecting via NFC When Camera Is Off or in Shooting Mode

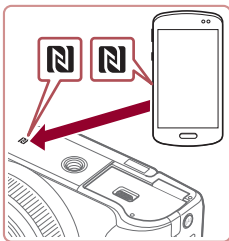

1 Install Camera Connect.

- Refer to the smartphone user manual to check where the N-Mark (N) is located.
- Activate NFC on the smartphone and touch the devices' N-Marks (N) together to start Google Play on the smartphone automatically. Once the Camera Connect download page is displayed, download and install the app.

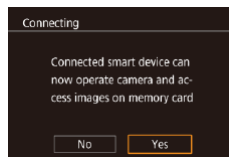
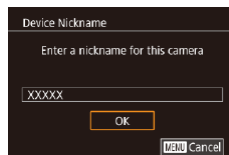

2 Establish the connection.

- Make sure the camera is off or in Shooting mode.
- Touch the N-Mark (N) on the smartphone with Camera Connect installed against the camera's N-Mark.
- The camera screen automatically changes.
- If the [Device Nickname] screen is displayed, press the [▲][▼] buttons or turn the [DIAL] dial to choose [OK], and then press the [OK] button.

- Camera Connect is started on the smartphone.
- The devices are connected automatically.

3 Adjust the privacy setting.

- When this screen is displayed, press the [◀][▶] buttons or turn the [DIAL] dial to choose [Yes], and then press the [OK] button.
- You can now use the smartphone for remote live view shooting, or to browse or transfer images on the camera.

Before Use

Basic Guide

Advanced Guide

Camera Basics

Auto Mode /
Hybrid Auto Mode

Other Shooting Modes

P Mode

Tv, Av, M, and C Mode

Playback Mode

Wireless Features

Setting Menu

Accessories

Appendix

Index





4 Send an image.

- Turn the [DISP] dial to choose an image to send, press the [L] [R] buttons to choose [Send this image], and then press the [SET] button.
- [Transfer completed] is displayed after the image is sent, and the image transfer screen is displayed again.
- To end the connection, press the [MENU] button, choose [OK] on the confirmation screen (either press the [L] [R] buttons or turn the [DISP] dial), and then press the [SET] button. You can also use the smartphone to end the connection.



- When using NFC, keep the following points in mind.
 - Avoid strong impact between the camera and smartphone. This may damage the devices.
 - Depending on the smartphone, the devices may not recognize each other immediately. In this case, try holding the devices together in slightly different positions. If connection is not established, keep the devices together until the camera screen is updated.
 - If you attempt connection when the camera is off, a message may be displayed on the smartphone reminding you to turn on the camera. If so, turn the camera on and touch the devices together again.
 - Do not place other objects between the camera and smartphone. Also, note that camera or smartphone covers or similar accessories may block communication.
- All images in the camera can be viewed from the connected smartphone when you choose [Yes] in step 3. To keep camera images private, so that they cannot be viewed from the smartphone, choose [No] in step 3.
- Privacy settings for registered smartphones can be changed later, as needed (167).



- Connections require that a memory card be in the camera.
- You can also change the camera nickname on the screen in step 2 (160).
- You can also send multiple images at once and change the image size before sending (160).
- To disable NFC connections, choose MENU (31) > [4] tab > [Wireless settings] > [Wi-Fi Settings] > [NFC] > [Off].

Connecting via NFC in Playback Mode

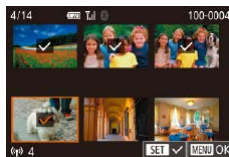

- Press the [R] button to turn the camera on.
- Touch the smartphone with Camera Connect installed (144) against the camera's N-Mark (N).
- Press the [▲] [▼] [L] [R] buttons to choose an image to send, and then press the [SET] button. [✓] is displayed.
- To cancel selection, press the [SET] button again. [✓] is no longer displayed.
- Repeat this process to choose additional images.
- After you finish choosing images, press the [MENU] button, choose [OK], and then press the [SET] button.
- Press the [L] [R] buttons to choose [Send], and then press the [SET] button.
- The images are now sent.
- To end the connection, press the [MENU] button, and then press the [L] [R] buttons to choose [OK].

Before Use

Basic Guide

Advanced Guide

Camera Basics

Auto Mode / Hybrid Auto Mode

Other Shooting Modes

P Mode

Tv, Av, M, and C Mode

Playback Mode

Wireless Features

Setting Menu

Accessories

Appendix

Index





- If during connection a message on the camera requests you to enter the nickname, enter it as described in "On-Screen Keyboard" (132).
- The camera does not keep a record of smartphones you connect to via NFC in Playback mode.
- You can preset images to transfer at your desired size (162).

Connecting to a Smartphone via the Wi-Fi Menu

These steps show how to use the camera as an access point, but you can also use an existing access point (147).



1 Install Camera Connect.

- For Android smartphones, find Camera Connect in Google Play and download and install the app.
- For an iPhone or iPad, find Camera Connect in the App Store and download and install the app.

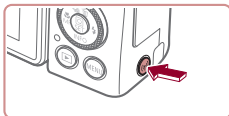

2 Access the Wi-Fi menu.

- Press the **[Wi-Fi]** button.
- If the [Device Nickname] screen is displayed, press the **[▲]**/**[▼]** buttons or turn the **[OK]** dial to choose [OK], and then press the **[SET]** button.

3 Choose [L].

- Press the **[◀]**/**[▶]** buttons or turn the **[OK]** dial to choose **[L]**, and then press the **[SET]** button.

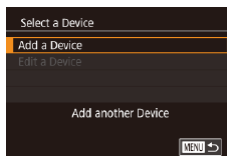
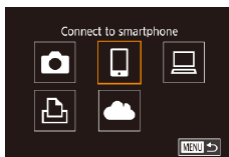

4 Choose [Add a Device].

- Press the **[▲]**/**[▼]** buttons or turn the **[OK]** dial to choose [Add a Device], and then press the **[SET]** button.

- The camera SSID and password are displayed.

5 Connect the smartphone to the network.

- In the smartphone's Wi-Fi setting menu, choose the SSID (network name) displayed on the camera to establish a connection.
- In the password field, enter the password displayed on the camera.



6 Start Camera Connect.

- Start Camera Connect on the smartphone.



7 Select the camera to connect to.

- On the camera selection screen displayed on the smartphone, choose the camera to begin pairing.

Before Use

Basic Guide

Advanced Guide

Camera Basics

Auto Mode / Hybrid Auto Mode

Other Shooting Modes

P Mode

Tv, Av, M, and C Mode

Playback Mode

Wireless Features

Setting Menu

Accessories

Appendix

Index



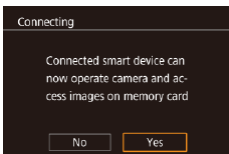

8 Adjust the privacy setting.

- Press the [◀][▶] buttons or turn the [DISP] dial to choose [Yes], and then press the [OK] button.
- You can now use the smartphone for remote live view shooting, or to browse or transfer images on the camera.

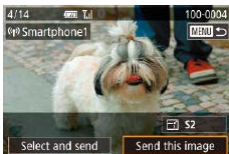

9 Send an image.

- Turn the [DISP] dial to choose an image to send, press the [◀][▶] buttons to choose [Send this image], and then press the [OK] button.
- [Transfer completed] is displayed after the image is sent, and the image transfer screen is displayed again.
- To end the connection, press the [MENU] button, choose [OK] on the confirmation screen (either press the [◀][▶] buttons or turn the [DISP] dial), and then press the [OK] button. You can also use the smartphone to end the connection.



- All images in the camera can be viewed from the connected smartphone when you choose [Yes] in step 8. To keep camera images private, so that they cannot be viewed from the smartphone, choose [No] in step 8.
- Privacy settings for registered smartphones can be changed later, as needed (167).



- Connections require that a memory card be in the camera.
- Once you have connected to devices via the Wi-Fi menu, recent destinations will be listed first when you access the Wi-Fi menu. You can easily connect again by pressing the [▲][▼] buttons to choose the device and then pressing the [OK] button. To add a new device, display the device selection screen by pressing the [◀][▶] buttons, and then configure the setting.
- If you prefer not to display recent target devices, choose MENU (31) > [4] tab > [Wireless settings] > [Wi-Fi Settings] > [Target History] > [Off].
- To connect without entering a password in step 5, choose MENU (31) > [4] tab > [Wireless settings] > [Wi-Fi Settings] > [Password] > [Off]. [Password] is no longer displayed on the SSID screen (in step 4).
- You can also send multiple images at once and change the image size before sending (160).
- Once a connection destination is assigned in Touch Actions (127), you can automatically reconnect to a previous destination simply by dragging across the screen with the assigned gesture.

Using Another Access Point

When connecting the camera to a smartphone through the Wi-Fi menu, you can also use an existing access point.

1 Prepare for the connection.

- Access the [Waiting to connect] screen by following steps 1 – 4 in "Connecting to a Smartphone via the Wi-Fi Menu" (146).

2 Connect the smartphone to the access point.



Before Use

Basic Guide

Advanced Guide

Camera Basics

Auto Mode / Hybrid Auto Mode

Other Shooting Modes

P Mode

Tv, Av, M, and C Mode

Playback Mode

Wireless Features

Setting Menu

Accessories

Appendix

Index



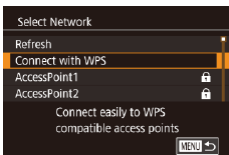
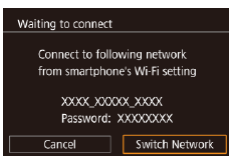

3 Choose [Switch Network].

- Press the [◀][▶] buttons or turn the [📶] dial to choose [Switch Network], and then press the [📶] button.
- A list of detected access points is displayed.

4 Connect to the access point and choose the smartphone.

- For WPS-compatible access points, connect to the access point as described in steps 5 – 8 in “Using WPS-Compatible Access Points” (📖 151).
- For non-WPS access points, follow steps 2 – 4 in “Connecting to Listed Access Points” (📖 153) to connect to the access point.

5 Select the camera to connect to.

- On the camera selection screen displayed on the smartphone, choose the camera to begin pairing.

6 Configure the privacy settings and send images.

- Follow steps 8 – 9 in “Connecting to a Smartphone via the Wi-Fi Menu” (📖 146) to configure the privacy settings and send images.

Previous Access Points

You can reconnect to any previous access points automatically by following step 4 in “Connecting to a Smartphone via the Wi-Fi Menu” (📖 146).

- To use the camera as an access point, choose [Switch Network] on the screen displayed when you establish a connection, and then choose [Camera Access Point Mode].
- To switch access points, choose [Switch Network] on the screen displayed when you establish a connection, and then follow the procedure in “Using Another Access Point” (📖 147) from step 4.

Before Use

Basic Guide

Advanced Guide

Camera Basics

Auto Mode /
Hybrid Auto Mode

Other Shooting Modes

P Mode

Tv, Av, M, and C Mode

Playback Mode

Wireless Features

Setting Menu

Accessories

Appendix

Index



Saving Images to a Computer

■ Preparing to Register a Computer

For details on computers that you can connect the camera to via Wi-Fi, system requirements, and other compatibility information (including support in new operating systems), visit the Canon website.



- Windows 7 Starter and Home Basic editions are not supported.
- Windows 7 N (European version) and KN (South Korean version) require a separate download and installation of Windows Media Feature Pack.

For details, check the following website.

<http://go.microsoft.com/fwlink/?LinkId=159730>

Installing CameraWindow

1 Download the software.

- Visit the following site from a computer connected to the Internet.

<http://www.canon.com/icpd/>

- Choose your country or region, and then follow the instructions displayed to prepare for downloading.

2 Follow the instructions displayed.

- Double-click the downloaded file to install it.



- Internet access is required, and any ISP account charges and access fees must be paid separately.



- To uninstall (remove) the software in Windows, select [Start] menu > [All Programs] > [Canon Utilities], and then choose the software for uninstallation.

Configuring the Computer for a Wi-Fi Connection (Windows Only)

On a computer running Windows, configure the following settings before connecting the camera to the computer wirelessly.



1 Confirm that the computer is connected to an access point.

- For instructions on checking your network connection, refer to the computer user manual.

2 Configure the setting.

- Click in the following order: [Start] menu > [All Programs] > [Canon Utilities] > [CameraWindow] > [Wi-Fi connection setup].
- In the application that opens, follow the on-screen instructions and configure the setting.

Before Use

Basic Guide

Advanced Guide

Camera Basics

Auto Mode /
Hybrid Auto Mode

Other Shooting Modes

P Mode

Tv, Av, M, and C Mode

Playback Mode

Wireless Features

Setting Menu

Accessories

Appendix

Index





- The following Windows settings are configured when you run the utility in step 2.
 - Turn on media streaming.
This will enable the camera to see (find) the computer to access via Wi-Fi.
 - Turn on network discovery.
This will enable the computer to see (find) the camera.
 - Turn on ICMP (Internet Control Message Protocol).
This allows you to check the network connection status.
 - Enable Universal Plug & Play (UPnP).
This will enable network devices to detect each other automatically.
- Some security software may prevent you from completing the settings as described here. Check the settings of your security software.

■ Saving Images to a Connected Computer

Connect to your access point via Wi-Fi as follows.
Also refer to the access point user manual.

Confirming Access Point Compatibility

Confirm that the Wi-Fi router or base station conforms to the Wi-Fi standards in “Interface” (📖225).

Connection methods vary depending on whether the access point supports Wi-Fi Protected Setup (WPS, 📖151) or not (📖153). For non-WPS access points, check the following information.

- Network name (SSID/ESSID)
The SSID or ESSID for the access point you use. Also called the “access point name” or “network name”.
- Network authentication / data encryption (encryption method / encryption mode)
The method for encrypting data during wireless transmission. Check which security setting is used: WPA2-PSK (AES), WPA2-PSK (TKIP), WPA-PSK (AES), WPA-PSK (TKIP), WEP (open system authentication), or no security.

- Password (encryption key / network key)
The key used when encrypting data during wireless transmission. Also called the “encryption key” or “network key”.
- Key index (transmit key)
The key set when WEP is used for network authentication / data encryption. Use “1” as the setting.



- If system administrator status is needed to adjust network settings, contact the system administrator for details.
- These settings are very important for network security. Exercise adequate caution when changing these settings.



- For information on WPS compatibility and for instructions on checking settings, refer to the access point user manual.
- A router is a device that creates a network (LAN) structure for connecting multiple computers. A router that contains an internal Wi-Fi function is called a “Wi-Fi router”.
- This guide refers to all Wi-Fi routers and base stations as “access points”.
- If you use MAC address filtering on your Wi-Fi network, be sure to add the camera’s MAC address to your access point. You can check your camera’s MAC address by choosing MENU (📖31) > [🔍4] tab > [Wireless settings] > [Wi-Fi Settings] > [Check MAC Address].

Before Use

Basic Guide

Advanced Guide

Camera Basics

Auto Mode /
Hybrid Auto Mode

Other Shooting Modes

P Mode

Tv, Av, M, and C Mode

Playback Mode

Wireless Features

Setting Menu

Accessories

Appendix

Index



Using WPS-Compatible Access Points

WPS makes it easy to complete settings when connecting devices over Wi-Fi. You can use either Push Button Configuration (PBC) Method or PIN Method to set up an access point that supports WPS.

1 Confirm that the computer is connected to an access point.

- For instructions on checking the connection, refer to the device and access point user manuals.

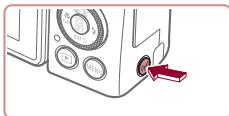

2 Access the Wi-Fi menu.

- Press the [Wi-Fi] button.

- If the [Device Nickname] screen is displayed, press the [▲][▼] buttons or turn the [Dial] dial to choose [OK], and then press the [Set] button.

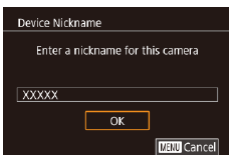

3 Choose [Computer].

- Press the [▲][▼][◀][▶] buttons or turn the [Dial] dial to choose [Computer], and then press the [Set] button.

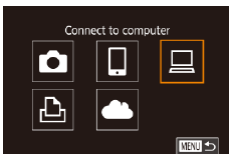

4 Choose [Add a Device].

- Press the [▲][▼] buttons or turn the [Dial] dial to choose [Add a Device], and then press the [Set] button.

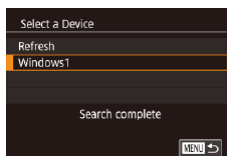
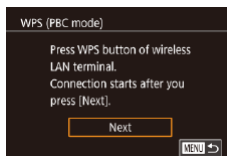
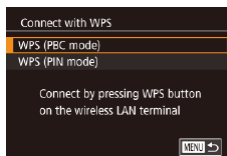
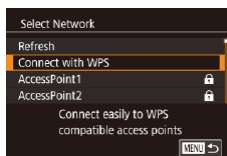
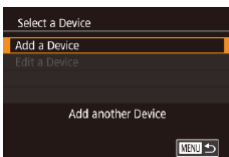

5 Choose [Connect with WPS].

- Press the [▲][▼] buttons or turn the [Dial] dial to choose [Connect with WPS], and then press the [Set] button.

6 Choose [WPS (PBC mode)].

- Press the [▲][▼] buttons or turn the [Dial] dial to choose [WPS (PBC mode)], and then press the [Set] button.

7 Establish the connection.

- On the access point, hold down the WPS connection button for a few seconds.
- On the camera, press the [Set] button to go to the next step.
- The camera connects to the access point and lists devices connected to it on the [Select a Device] screen.

8 Choose the target device.

- Choose the target device name (either press the [▲][▼] buttons or turn the [Dial] dial), and then press the [Set] button.

Before Use

Basic Guide

Advanced Guide

Camera Basics

Auto Mode / Hybrid Auto Mode

Other Shooting Modes

P Mode

Tv, Av, M, and C Mode

Playback Mode

Wireless Features

Setting Menu

Accessories

Appendix

Index





9 Install a driver (first Windows connection only).

- When this screen is displayed on the camera, click the Start menu on the computer, click [Control Panel], and then click [Add a device].

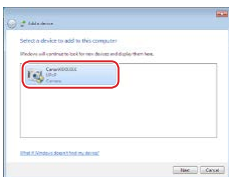
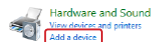

- Double-click the connected camera icon.
- Driver installation will begin.
- After driver installation is complete, and the camera and computer connection is enabled, the AutoPlay screen will be displayed. Nothing will be displayed on the camera screen.

10 Display CameraWindow.

- Windows: Access CameraWindow by clicking [Downloads Images From Canon Camera].

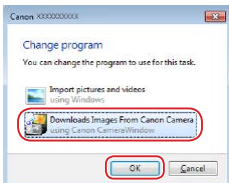

11 Import images.

- Click [Import Images from Camera], and then click [Import Untransferred Images].
- Images are now saved to the Pictures folder on the computer, in separate folders named by date.
- Click [OK] in the screen that is displayed after image import is complete.
- To view images you save to a computer, use preinstalled or commonly available software compatible with images captured by the camera.



- Once you have connected to devices via the Wi-Fi menu, recent destinations will be listed first when you access the Wi-Fi menu. You can easily connect again by pressing the [▲][▼] buttons to choose the device and then pressing the [📶] button. To add a new device, display the device selection screen by pressing the [◀][▶] buttons, and then configure the setting.
- If you prefer not to display recent target devices, choose MENU (📖31) > [4] tab > [Wireless settings] > [Wi-Fi Settings] > [Target History] > [Off].
- You can also change the camera nickname on the screen in step 2 (📖168).
- When the camera is connected to a computer, the camera screen is blank.
- To disconnect from the camera, turn off the camera.
- The PIN code displayed when you choose [WPS (PIN mode)] in step 6 is to be set in the access point. Choose a device in the [Select a Device] screen. For further details, refer to the user manual included with your access point.
- Once a connection destination is assigned in Touch Actions (📖127), you can automatically reconnect to a previous destination simply by dragging across the screen with the assigned gesture.

Before Use

Basic Guide

Advanced Guide

Camera Basics

Auto Mode /
Hybrid Auto Mode

Other Shooting Modes

P Mode

Tv, Av, M, and C Mode

Playback Mode

Wireless Features

Setting Menu

Accessories

Appendix

Index



Connecting to Listed Access Points

1 View the listed access points.

- View the listed networks (access points) as described in steps 1 – 4 of “Using WPS-Compatible Access Points” (📖 151).

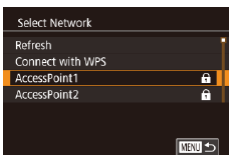

2 Choose an access point.

- Press the [▲][▼] buttons or turn the [🌀] dial to choose a network (access point), and then press the [🔑] button.



3 Enter the access point password.

- Press the [🔑] button to access the keyboard, and then enter the password (📖 32).
- Press the [▲][▼] buttons or turn the [🌀] dial to choose [Next], and then press the [🔑] button.

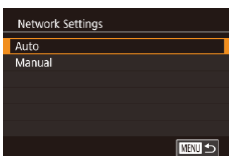

4 Choose [Auto].

- Press the [▲][▼] buttons or turn the [🌀] dial to choose [Auto], and then press the [🔑] button.
- To save images to a connected computer, follow the procedure from step 8 in “Using WPS-Compatible Access Points” (📖 151).



- To determine the access point password, check on the access point itself or refer to the user manual.
- If no access points are detected even after you choose [Refresh] in step 2 to update the list, choose [Manual Settings] in step 2 to complete access point settings manually. Follow on-screen instructions and enter an SSID, security settings, and a password.
- When you use an access point that you have already connected to for connecting to another device, [*] is displayed for the password in step 3. To use the same password, choose [Next] (either press the [▲][▼] buttons or turn the [🌀] dial) and press the [🔑] button.

Previous Access Points

You can reconnect to any previous access points automatically by following step 4 in “Using WPS-Compatible Access Points” (📖 151).

- To connect to a device via an access point, confirm that the target device is already connected to the access point, and then follow the procedure from step 8 in “Using WPS-Compatible Access Points” (📖 151).
- To switch access points, choose [Switch Network] on the screen displayed when you establish a connection, and then either follow the procedure in “Using WPS-Compatible Access Points” (📖 151) from step 5 or the procedure in “Connecting to Listed Access Points” (📖 153) from step 2.

Before Use

Basic Guide

Advanced Guide

Camera Basics

Auto Mode /
Hybrid Auto Mode

Other Shooting Modes

P Mode

Tv, Av, M, and C Mode

Playback Mode

Wireless Features

Setting Menu

Accessories

Appendix

Index



Sending Images to a Registered Web Service

Registering Web Services

Use a smartphone or computer to add your Web services to the camera.

- A smartphone or computer with a browser and Internet connection is required to complete camera settings for CANON IMAGE GATEWAY and other Web services.
- Check the CANON IMAGE GATEWAY website for details on browser (Microsoft Internet Explorer, etc.) requirements, including settings and version information.
- For information on countries and regions where CANON IMAGE GATEWAY is available, visit the Canon website (<http://www.canon.com/cig/>).
- To use Web services other than CANON IMAGE GATEWAY, you must have an account with them. For further details, check the websites for each Web service you want to register.
- Separate ISP connection and access point fees may apply.



- CANON IMAGE GATEWAY also provides user guides for downloading.

Registering CANON iMAGE GATEWAY

Link the camera and CANON iMAGE GATEWAY by adding CANON iMAGE GATEWAY as a destination Web service on the camera. Note that you will need to enter an email address used on your computer or smartphone to receive a notification message for completing linkage settings.

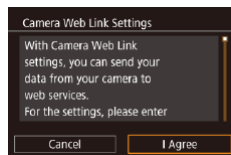
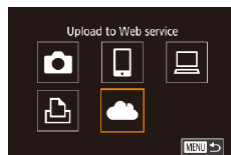
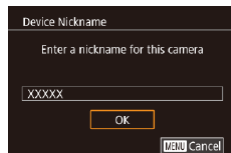
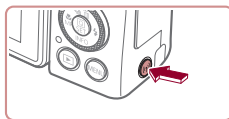

1 Access the Wi-Fi menu.

- Press the $\left[\left(\text{Wi-Fi}\right)\right]$ button.

- If the [Device Nickname] screen is displayed, press the $\left[\blacktriangle\right]\left[\blacktriangledown\right]$ buttons or turn the $\left[\text{DIAL}\right]$ dial to choose [OK], and then press the $\left[\text{SET}\right]$ button.

2 Choose $\left[\text{Cloud}\right]$.

- Press the $\left[\blacktriangle\right]\left[\blacktriangledown\right]\left[\leftarrow\right]\left[\rightarrow\right]$ buttons or turn the $\left[\text{DIAL}\right]$ dial to choose $\left[\text{Cloud}\right]$, and then press the $\left[\text{SET}\right]$ button.

3 Accept the agreement to enter an email address.

- Read the agreement displayed, press the $\left[\leftarrow\right]\left[\rightarrow\right]$ buttons or turn the $\left[\text{DIAL}\right]$ dial to choose [I Agree], and then press the $\left[\text{SET}\right]$ button.

Before Use

Basic Guide

Advanced Guide

Camera Basics

Auto Mode /
Hybrid Auto Mode

Other Shooting Modes

P Mode

Tv, Av, M, and C Mode

Playback Mode

Wireless Features

Setting Menu

Accessories

Appendix

Index



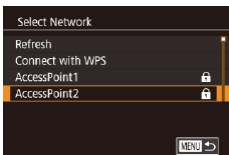

4 Establish a connection with an access point.

- Connect to the access point as described in steps 5 – 7 in “Using WPS-Compatible Access Points” (📖151) or in steps 2 – 4 in “Connecting to Listed Access Points” (📖153).

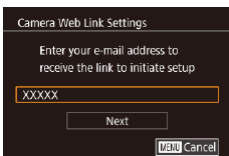

5 Enter your email address.

- Once the camera is connected to CANON iMAGE GATEWAY via the access point, a screen is displayed for entering an email address.
- Enter your email address, press the [▲][▼] buttons or turn the [🌀] dial to choose [Next], and then press the [📶] button.

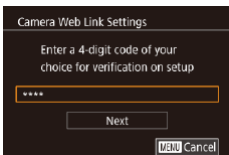

6 Enter a four-digit number.

- Enter a four-digit number of your choice, press the [▲][▼] buttons or turn the [🌀] dial to choose [Next], and then press the [📶] button.
- You will need this four-digit number later when setting up linkage with CANON iMAGE GATEWAY in step 8.

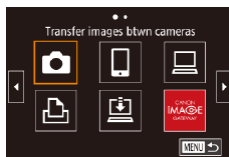
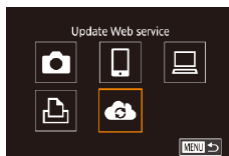
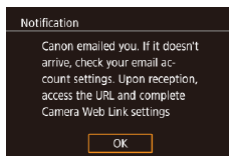

7 Check for the notification message.

- Once information has been sent to CANON iMAGE GATEWAY, you will receive a notification message at the email address entered in step 5.
- Press the [📶] button on the next screen, which indicates that notification has been sent.
- [☁️] now changes to [☑️].

8 Access the page in the notification message and complete camera link settings.

- From a computer or smartphone, access the page linked in the notification message.
- Follow the instructions to complete the settings on the camera link settings page.

9 Complete CANON iMAGE GATEWAY settings on the camera.

- Press the [▲][▼][◀][▶] buttons or turn the [🌀] dial to choose [☑️], and then press the [📶] button.
- [📖] (📖162) and CANON iMAGE GATEWAY are now added as destinations.
- You can add other Web services, as needed. In this case, follow the instructions from step 2 in “Registering Other Web Services” (📖156).

Before Use

Basic Guide

Advanced Guide

Camera Basics

Auto Mode /
Hybrid Auto Mode

Other Shooting Modes

P Mode

Tv, Av, M, and C Mode

Playback Mode

Wireless Features

Setting Menu

Accessories

Appendix

Index





- Make sure initially that your computer or smartphone mail application is not configured to block email from relevant domains, which may prevent you from receiving the notification message.



- You can also change the camera nickname on the screen in step 1 (168).
- Once you have connected to devices via the Wi-Fi menu, recent destinations will be listed first when you access the menu. Press the [◀][▶] buttons to access the device selection screen and then configure the setting.
- Once a connection destination is assigned in Touch Actions (127), you can automatically reconnect to a previous destination simply by dragging across the screen with the assigned gesture.

Registering Other Web Services

You can also add Web services besides CANON iMAGE GATEWAY to the camera.



1 Log in to CANON iMAGE GATEWAY and access the camera link settings page.

- From a computer or smartphone, access <http://www.canon.com/cig/> to visit CANON iMAGE GATEWAY.



2 Configure the Web service you want to use.

- On the computer or smartphone, display the Web service settings screen.
- Follow the on-screen instructions to complete settings for Web services you want to use.

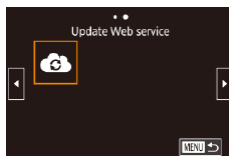

3 Choose [G].

- Press the [(P)] button.
- Press the [▲][▼][◀][▶] buttons or turn the [DIAL] dial to choose [G], and then press the [OK] button.
- The Web service settings are now updated.



- If any configured settings change, follow these steps again to update the camera settings.

Uploading Images to Web Services

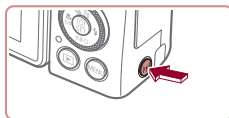

1 Access the Wi-Fi menu.

- Press the [(P)] button.

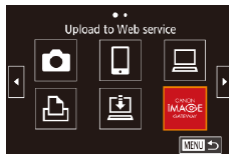

2 Choose the destination.

- Choose the icon of the Web service to connect to (either press the [▲][▼][◀][▶] buttons or turn the [DIAL] dial), and then press the [OK] button.
- If multiple recipients or sharing options are used with a Web service, choose the desired item on the [Select Recipient] screen (either press the [▲][▼] buttons or turn the [DIAL] dial), and then press the [OK] button.

Before Use

Basic Guide

Advanced Guide

Camera Basics

Auto Mode / Hybrid Auto Mode

Other Shooting Modes

P Mode

Tv, Av, M, and C Mode

Playback Mode

Wireless Features

Setting Menu

Accessories

Appendix

Index



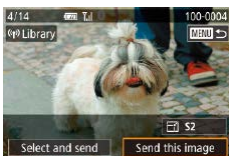

3 Send an image.

- Turn the [Q] dial to choose an image to send, press the [L][R] buttons to choose [Send this image], and then press the [SET] button.
- When uploading to YouTube, read the terms of service, choose [I Agree], and press the [SET] button.
- Press the [SET] button to return to the playback screen once [OK] is displayed after the image is sent.



- Connections require that a memory card with saved images be in the camera.
- You can also send multiple images at once, resize images, and add comments before sending (160).
- To view images uploaded to CANON iMAGE GATEWAY on a smartphone, try the dedicated Canon Online Photo Album app. Download and install the Canon Online Photo Album app for iPhones or iPads from the App Store or for Android devices from Google Play.

Printing Images Wirelessly from a Connected Printer

Connect the camera to a printer via Wi-Fi to print as follows. These steps show how to use the camera as an access point, but you can also use an existing access point (147).

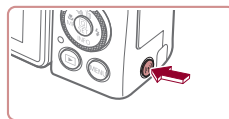

1 Access the Wi-Fi menu.

- Press the [W] button.

2 Choose [Print].

- Press the [▲][▼][◀][▶] buttons or turn the [Q] dial to choose [Print], and then press the [SET] button.



3 Choose [Add a Device].

- Press the [▲][▼] buttons or turn the [Q] dial to choose [Add a Device], and then press the [SET] button.
- The camera SSID and password are displayed.

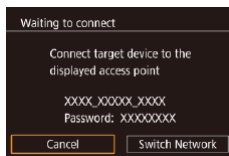
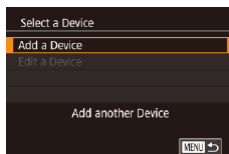

Before Use

Basic Guide

Advanced Guide

Camera Basics

Auto Mode /
Hybrid Auto Mode

Other Shooting Modes

P Mode

Tv, Av, M, and C Mode

Playback Mode

Wireless Features

Setting Menu

Accessories

Appendix

Index





4 Connect the printer to the network.

- In the printer's Wi-Fi setting menu, choose the SSID (network name) displayed on the camera to establish a connection.
- In the password field, enter the password displayed on the camera.

5 Choose the printer.

- Choose the printer name (either press the [▲][▼] buttons or turn the [●] dial), and then press the [⊞] button.

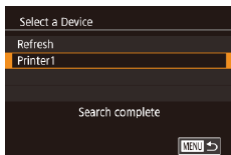

6 Choose an image.

- Press the [◀][▶] buttons or turn the [●] dial to choose an image.

7 Access the printing screen.

- Press the [⊞] button, choose [⏏] in the menu (either press the [▲][▼][◀][▶] buttons or turn the [●] dial), and then press the [⊞] button again.

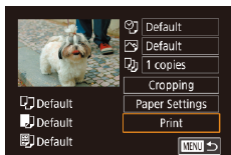

8 Print the image.

- For detailed printing instructions, see "Printing Images" (191).
- To end the connection, press the [⏏] button, choose [OK] on the disconnection confirmation screen (either press the [◀][▶] buttons or turn the [●] dial), and then press the [⊞] button.



- Connections require that a memory card with saved images be in the camera.
- Once you have connected to devices via the Wi-Fi menu, recent destinations will be listed first when you access the Wi-Fi menu. You can easily connect again by pressing the [▲][▼] buttons to choose the device and then pressing the [⊞] button. To add a new device, display the device selection screen by pressing the [◀][▶] buttons, and then configure the setting.
- If you prefer not to display recent target devices, choose MENU (31) > [4] tab > [Wireless settings] > [Wi-Fi Settings] > [Target History] > [Off].
- To connect without entering a password in step 4, choose MENU (31) > [4] tab > [Wireless settings] > [Wi-Fi Settings] > [Password] > [Off]. [Password] is no longer displayed on the SSID screen (in step 3).
- To use another access point, follow steps 3 – 4 in "Using Another Access Point" (147).
- Once a connection destination is assigned in Touch Actions (127), you can automatically reconnect to a previous destination simply by dragging across the screen with the assigned gesture.

Before Use

Basic Guide

Advanced Guide

Camera Basics

Auto Mode / Hybrid Auto Mode

Other Shooting Modes

P Mode

Tv, Av, M, and C Mode

Playback Mode

Wireless Features

Setting Menu

Accessories

Appendix

Index



Sending Images to Another Camera

Connect two cameras via Wi-Fi and send and receive images between them as follows.

- Only Wi-Fi compatible Canon cameras can be connected via Wi-Fi. You cannot connect to a Canon camera unless it is Wi-Fi compatible, even if it supports Eye-Fi cards.

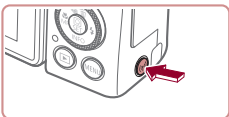

1 Access the Wi-Fi menu.

- Press the [Wi-Fi] button.

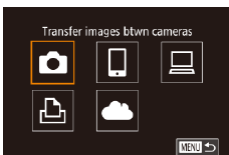

2 Choose [Camera].

- Press the [Up][Down][Left][Right] buttons or turn the [Dial] dial to choose [Camera], and then press the [Set] button.

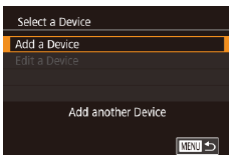

3 Choose [Add a Device].

- Press the [Up][Down] buttons or turn the [Dial] dial to choose [Add a Device], and then press the [Set] button.
- Also follow steps 1 – 3 on the target camera.
- Camera connection information will be added when [Start connection on target camera] is displayed on both camera screens.

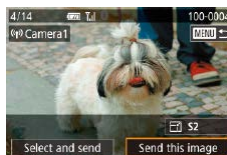

4 Send an image.

- Turn the [Dial] dial to choose an image to send, press the [Left][Right] buttons to choose [Send this image], and then press the [Set] button.
- [Transfer completed] is displayed after the image is sent, and the image transfer screen is displayed again.
- To end the connection, press the [MENU] button, choose [OK] on the confirmation screen (either press the [Left][Right] buttons or turn the [Dial] dial), and then press the [Set] button.



- Connections require that a memory card be in the camera.
- Once you have connected to devices via the Wi-Fi menu, recent destinations will be listed first when you access the Wi-Fi menu. You can easily connect again by pressing the [Up][Down] buttons to choose the device and then pressing the [Set] button. To add a new device, display the device selection screen by pressing the [Left][Right] buttons, and then configure the setting.
- If you prefer not to display recent target devices, choose MENU (31) > [Y4] tab > [Wireless settings] > [Wi-Fi Settings] > [Target History] > [Off].
- You can also send multiple images at once and change the image size before sending (160, 162).
- Once a connection destination is assigned in Touch Actions (127), you can automatically reconnect to a previous destination simply by dragging across the screen with the assigned gesture.

Before Use

Basic Guide

Advanced Guide

Camera Basics

Auto Mode /
Hybrid Auto Mode

Other Shooting Modes

P Mode

Tv, Av, M, and C Mode

Playback Mode

Wireless Features

Setting Menu

Accessories

Appendix

Index



Image Sending Options

You can choose multiple images to send at once and change the image recording pixel setting (size) before sending. Some Web services also enable you to annotate the images you send.

Sending Multiple Images

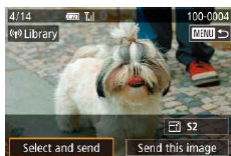

1 Choose [Select and send].

- On the image transfer screen, press the [◀][▶] buttons to choose [Select and send], and then press the [OK] button.

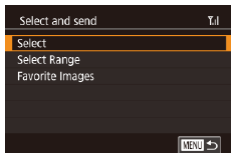

2 Choose a selection method.

- Press the [▲][▼] buttons or turn the [DISP] dial to choose a selection method.

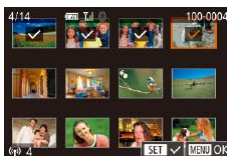

2 Choose an image.

- Press the [▲][▼][◀][▶] buttons to choose an image to send, and then press the [OK] button. [✓] is displayed.
- To cancel selection, press the [DISP] button again. [✓] is no longer displayed.
- Repeat this process to choose additional images.
- After you finish choosing images, press the [MENU] button.
- Press the [◀][▶] buttons or turn the [DISP] dial to choose [OK], and then press the [OK] button.

3 Send the images.

- Press the [◀][▶] buttons or turn the [DISP] dial to choose [Send], and then press the [OK] button.



- You can also choose images in step 2 by moving the zoom lever twice toward [Q] to access single-image display and then pressing the [◀][▶] buttons or turning the [DISP] dial.

Choosing Images Individually

1 Choose [Select].

- Following step 2 in “Sending Multiple Images” (p.160), choose [Select] and press the [OK] button.

Selecting a Range

1 Choose [Select Range].

- Following step 2 in “Sending Multiple Images” (p.160), choose [Select Range] and press the [OK] button.

Before Use

Basic Guide

Advanced Guide

Camera Basics

Auto Mode / Hybrid Auto Mode

Other Shooting Modes

P Mode

Tv, Av, M, and C Mode

Playback Mode

Wireless Features

Setting Menu

Accessories

Appendix

Index



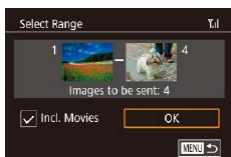

2 Choose images.

- Follow steps 2 – 3 in “Selecting a Range” (📖 122) to specify images.
- To include movies, press the [▲][▼][◀][▶] buttons to choose [Incl. Movies], and then press the [⊕] button to mark the option as selected (✓).
- Press the [▲][▼][◀][▶] buttons to choose [OK], and then press the [⊕] button.

3 Send the images.

- Press the [◀][▶] buttons or turn the [⊕] dial to choose [Send], and then press the [⊕] button.

Sending Favorite Images

Send only images tagged as favorites (📖 126).

1 Choose [Favorite Images].

- Following step 2 in “Sending Multiple Images” (📖 160), choose [Favorite Images] and press the [⊕] button.
- An image selection screen for favorites is displayed. If you prefer not to include an image, choose the image and press the [⊖] button to remove [✓].
- After you finish choosing images, press the [MENU] button, choose [OK], and then press the [⊕] button.

2 Send the images.

- Press the [◀][▶] buttons or turn the [⊕] dial to choose [Send], and then press the [⊕] button.



- In step 1, [Favorite Images] is not available unless you have tagged images as favorites.

Notes on Sending Images

- Depending on the condition of the network you are using, it may take a long time to send movies. Be sure to keep an eye on the camera battery level.
- Web services may limit the number of images or length of movies you can send.
- For movies that you do not compress (📖 135), a separate, compressed file is sent instead of the original file. Note that this may delay transmission, and the file cannot be sent unless there is enough space for it on the memory card.
- When sending movies to smartphones, note that the supported image quality varies depending on the smartphone. For details, refer to the smartphone user manual.
- On the screen, wireless signal strength is indicated by the following icons:
[📶] high, [📶] medium, [📶] low, [📶] weak
- Sending images to Web services will take less time when resending images you have already sent that are still on the CANON iMAGE GATEWAY server.

Before Use

Basic Guide

Advanced Guide

Camera Basics

Auto Mode /
Hybrid Auto Mode

Other Shooting Modes

P Mode

Tv, Av, M, and C Mode

Playback Mode

Wireless Features

Setting Menu

Accessories

Appendix

Index



Choosing the Number of Recording Pixels (Image Size)

On the image transfer screen, choose [F] by pressing the [▲][▼] buttons, and then press the [S] button. On the screen displayed, choose the recording pixel setting (image size) by pressing the [▲][▼] buttons, and then press the [S] button.

- To send images at original size, select [No] as the resizing option.
- Choosing [S2] will resize images that are larger than the selected size before sending.
- Movies cannot be resized.



- Image size can also be configured in MENU (31) > [4] tab > [Wireless settings] > [Wi-Fi Settings] > [Resize for Sending].

Adding Comments

Using the camera, you can add comments to images that you send to email recipients or social networking services. The number of characters and symbols that can be entered may differ depending on the Web service.

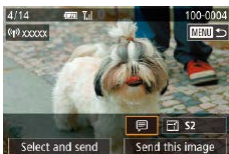

1 Access the screen for adding comments.

- On the image transfer screen, choose [F] by pressing the [▲][▼][◀][▶] buttons, and then press the [S] button.

2 Add a comment (32).

3 Send the image.



- When a comment is not entered, the comment set in CANON iIMAGE GATEWAY is automatically sent.
- You can also annotate multiple images before sending them. The same comment is added to all images sent together.

Sending Images Automatically (Image Sync)

Images on the memory card that have not been transferred already can be sent to a computer or Web services via CANON iIMAGE GATEWAY. Note that images cannot be sent only to Web services.

Initial Preparations

Preparing the Camera

Register [E] as the destination. On the destination computer, you will install and configure Image Transfer Utility, free software compatible with Image Sync.



1 Add [E] as a destination.

- Add [E] as a destination, as described in "Registering CANON iIMAGE GATEWAY" (154).
- To include a Web service as the destination, log in to CANON iIMAGE GATEWAY (154), select your camera model, access the Web service settings screen, and choose the destination Web service in Image Sync settings. For details, refer to CANON iIMAGE GATEWAY Help.

2 Choose the type of images to send (only when sending movies with images).

- Press the [MENU] button, choose [Wireless settings] on the [4] tab, and then choose [Wi-Fi Settings] (31).
- Press the [▲][▼] buttons to choose [Image Sync], and then press the [▲][▼] buttons to choose [Stills/Movies].

Before Use

Basic Guide

Advanced Guide

Camera Basics

Auto Mode /
Hybrid Auto Mode

Other Shooting Modes

P Mode

Tv, Av, M, and C Mode

Playback Mode

Wireless Features

Setting Menu

Accessories

Appendix

Index



Preparing the Computer



Install and configure the software on the destination computer.



1 Install Image Transfer Utility.

- Install Image Transfer Utility on a computer connected to the Internet by following steps 1 – 2 of “Installing CameraWindow” (📖 149).
- Image Transfer Utility can also be downloaded from the Image Sync settings page of CANON iMAGE GATEWAY (📖 162).



2 Register the camera.

- Windows: In the taskbar, right-click , and then click [Add new camera].
- Mac OS: In the menu bar, click , and then click [Add new camera].
- A list of cameras linked to CANON iMAGE GATEWAY is displayed. Choose the camera to send images from.
- Once the camera is registered and the computer is ready to receive images, the icon changes to .

Sending Images

Images sent from the camera are automatically saved to the computer. If the computer that you intend to send images to is turned off, the images will be stored temporarily on the CANON iMAGE GATEWAY server. Stored images are regularly erased, so make sure to turn on the computer and save the images.

1 Send images.

- Follow steps 1 – 2 in “Uploading Images to Web Services” (📖 156) and choose .
- Sent images are labeled with a .

2 Save the images to the computer.

- Images are automatically saved to the computer when you turn it on.
- Images are automatically sent to Web services from the CANON iMAGE GATEWAY server, even if the computer is off.



- When sending images, you should use a fully charged battery pack.



- Even if images were imported to the computer through a different method, any images not sent to the computer via CANON iMAGE GATEWAY will be sent to the computer.
- Sending is faster when the destination is a computer on the same network as the camera, because images are sent via the access point instead of CANON iMAGE GATEWAY. Note that images stored on the computer are sent to CANON iMAGE GATEWAY, so the computer must be connected to the Internet.

Before Use

Basic Guide

Advanced Guide

Camera Basics

Auto Mode /
Hybrid Auto Mode

Other Shooting Modes

P Mode

Tv, Av, M, and C Mode

Playback Mode

Wireless Features

Setting Menu

Accessories

Appendix

Index



Viewing Images Sent via Image Sync on a Smartphone

By installing the Canon Online Photo Album (Canon OPA) app, you can use your smartphone to view and download images sent via Image Sync while they are stored temporarily on the CANON iMAGE GATEWAY server.

In preparation, enable smartphone access as follows.

- Make sure you have completed the settings described in “Preparing the Computer” (📖163).
- Download and install the Canon Online Photo Album app for iPhones or iPads from the App Store or for Android devices from Google Play.
- Log in to CANON iMAGE GATEWAY (📖154), select your camera model, access the Web service settings screen, and enable viewing and downloading from a smartphone in the Image Sync settings. For details, refer to CANON iMAGE GATEWAY Help.



- Once images stored temporarily on the CANON iMAGE GATEWAY server have been deleted, they can no longer be viewed.
- Images you sent before enabling smartphone viewing and downloading in Image Sync settings cannot be accessed this way.



- For Canon Online Photo Album instructions, refer to Canon Online Photo Album Help.

Using a Smartphone to View Camera Images and Control the Camera

You can do the following with the dedicated smartphone app Camera Connect.

- Browse images on the camera and save them to the smartphone
- Geotag images as you shoot (📖164)
- Control the camera remotely from a smartphone (📖165)



- Privacy settings must be configured in advance to allow image viewing on the smartphone (📖144, 📖146, 📖167).

Geotagging Images When You Shoot

Still images and movies you shoot can be geotagged using GPS information (such as latitude, longitude, and elevation) from a Bluetooth enabled smartphone. You can review the recorded GPS information on the camera (📖113). Using the software (📖189), you can also view the locations on a map, with the still images and movies shown next to them.

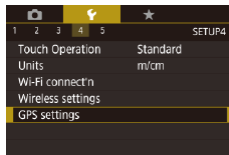

1 Pair the camera and smartphone via Bluetooth (📖142).

2 Choose [GPS settings].

- Press the [MENU] button, choose [GPS settings] on the [4] tab, and then press the [OK] button.

Before Use

Basic Guide

Advanced Guide

Camera Basics

Auto Mode /
Hybrid Auto Mode

Other Shooting Modes

P Mode

Tv, Av, M, and C Mode

Playback Mode

Wireless Features

Setting Menu

Accessories

Appendix

Index



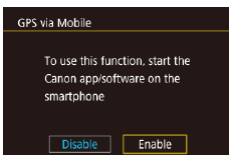

3 Configure the setting.

- Choose [GPS via Mobile], and then press the [◀][▶] buttons or turn the [DISP] dial to choose [Enable].

4 Shoot.

- The still images and movies you shoot are now geotagged using smartphone GPS information, which you can check as described in “GPS Information Display” (113).
- Next time, after starting Camera Connect on your smartphone, make sure the camera and smartphone are connected via Bluetooth before shooting.



- Images are not geotagged this way unless Camera Connect is running.
- The GPS information added to your movie is acquired initially, when you start shooting.
- GPS information cannot be updated unless Wi-Fi is off.
- The GPS information added to images in remote live view shooting is acquired initially, when you switch to a Wi-Fi connection.
- Images may not be geotagged if you connect via NFC or Bluetooth when the camera is off.
- Others may be able to locate or identify you by using location data in your geotagged still images or movies. Be careful when sharing these images with others, as when posting images online where many others can view them.



- GPS acquisition status is indicated by one of the following icons. [GPS] Acquiring, [GPS] Not acquiring
- To check the GPS information acquired from the smartphone, choose MENU (131) > [4] tab > [GPS settings] > [GPS information display].

Controlling the Camera Remotely from a Smartphone

Controlling the Camera via Wi-Fi

You can take shots or record movies as you view a shooting screen on your smartphone.



- Privacy settings must be configured in advance to allow viewing of all images from the smartphone (146).

1 Secure the camera.

- Keep the camera still by mounting it on a tripod or taking other measures.

2 Connect the camera and smartphone (146).

- In the privacy settings, choose [Yes].

3 Choose remote live view shooting.

- In Camera Connect on the smartphone, choose [Remote live view shooting].
- Once the camera is ready for remote live view shooting, a live image from the camera is displayed on the smartphone.
- At this time, a message is displayed on the camera, and all operations except pressing the power button are disabled.

4 Shoot.

- Use the smartphone to shoot.

Before Use

Basic Guide

Advanced Guide

Camera Basics

Auto Mode / Hybrid Auto Mode

Other Shooting Modes

P Mode

Tv, Av, M, and C Mode

Playback Mode

Wireless Features

Setting Menu

Accessories

Appendix

Index





- Focusing may take longer.
- Image display or shutter release may be delayed, depending on the connection status.



- Any rough subject motion shown on the smartphone due to the connection environment will not affect recorded images.
- Captured images are not transferred to the smartphone. Use the smartphone to browse and transfer images from the camera.

Controlling the Camera via Bluetooth

You can use a Bluetooth enabled smartphone for remote shooting and switching of image display. This is convenient if you want to connect quickly while shooting, or if you will control playback while connected to a TV.

1 Prepare the camera.

- Set the shooting mode and the shooting functions on the camera.
- Keep the camera still by mounting it on a tripod or taking other measures when shooting.

2 Connect the camera and smartphone (142).

- Make sure that the Bluetooth connection has been established.

3 Choose Bluetooth remote controller.

- In Camera Connect on the smartphone, choose [Bluetooth remote controller].
- The smartphone screen changes to a screen for remote control via Bluetooth.

4 Shoot and switch images.

- Use the smartphone to shoot in Shooting mode and switch images in Playback mode.



- [Bluetooth remote controller] is not available when connected via Wi-Fi.



- You can check the Bluetooth connection status by referring to the icon on the screen (142).

Before Use

Basic Guide

Advanced Guide

Camera Basics

Auto Mode /
Hybrid Auto Mode

Other Shooting Modes

P Mode

Tv, Av, M, and C Mode

Playback Mode

Wireless Features

Setting Menu

Accessories

Appendix

Index



Editing or Erasing Wi-Fi Settings

Edit or erase Wi-Fi settings as follows.

Editing Connection Information

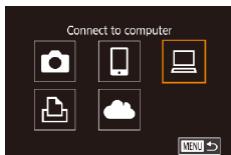

1 Access the Wi-Fi menu and choose a device to edit.

- Press the [Fn] button.
- Press the [▲][▼][◀][▶] buttons or turn the [DIAL] dial to choose the icon of a device to edit, and then press the [OK] button.

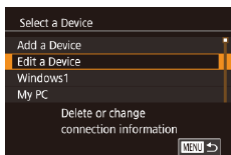

2 Choose [Edit a Device].

- Press the [▲][▼] buttons or turn the [DIAL] dial to choose [Edit a Device], and then press the [OK] button.

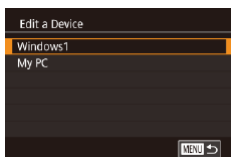

3 Choose the device to edit.

- Press the [▲][▼] buttons or turn the [DIAL] dial to choose the device to edit, and then press the [OK] button.

4 Choose the item to edit.

- Press the [▲][▼] buttons or turn the [DIAL] dial to choose the item to edit, and then press the [OK] button.
- The items you can change depend on the device or service.

Configurable Items	Connection				
					Web Services
[Change Device Nickname] (167)	○	○	○	○	—
[View Settings] (168)	—	○	—	—	—
[Erase Connection Info] (167)	○	○	○	○	—

○ : Configurable — : Not configurable

Changing a Device Nickname

You can change the device nickname (display name) that is displayed on the camera.

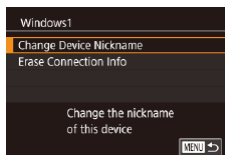

- Following step 4 in “Editing Connection Information” (167), choose [Change Device Nickname] and press the [OK] button.
- Press the [Fn] button to access the keyboard (32), and then enter a new nickname.

Erasing Connection Information

Erase connection information (information about devices that you have connected to) as follows.

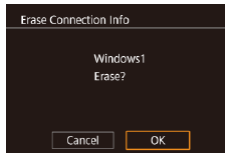

- Following step 4 in “Editing Connection Information” (167), choose [Erase Connection Info] and press the [OK] button.
- After [Erase?] is displayed, press the [◀][▶] buttons or turn the [DIAL] dial to choose [OK], and then press the [OK] button.
- The connection information will be erased.

Before Use

Basic Guide

Advanced Guide

Camera Basics

Auto Mode / Hybrid Auto Mode

Other Shooting Modes

P Mode

Tv, Av, M, and C Mode

Playback Mode

Wireless Features

Setting Menu

Accessories

Appendix

Index



Specifying Images Viewable from Smartphones

Specify whether all images on the camera's memory card can be viewed from smartphones connected to the camera.

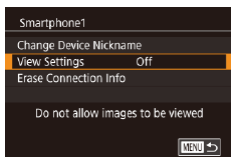

- Choose [View Settings] in step 4 of “Editing Connection Information” (167) and choose the desired option.



- For remote live view shooting, choose [On].

Changing the Camera Nickname

Change the camera nickname (displayed on connected devices) as desired.

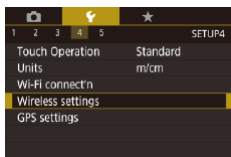

1 Choose [Wireless settings].

- Press the [MENU] button and choose [Wireless settings] on the [4] tab (31).

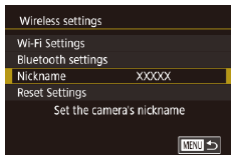

2 Choose [Nickname].

- Press the [▲][▼] buttons or turn the [DIAL] dial to choose [Nickname], and then press the [SET] button.

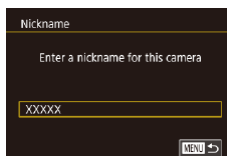

3 Change the nickname.

- Press the [SET] button to access the keyboard (32), and then enter a nickname.



- A message is displayed if the nickname you enter begins with a symbol or space. Press the [SET] button and enter a different nickname.
- You can also change the nickname from the [Device Nickname] screen displayed when you first use Wi-Fi. In this case, select the text box, press the [SET] button to access the keyboard, and then enter a new nickname.

Before Use

Basic Guide

Advanced Guide

Camera Basics

Auto Mode /
Hybrid Auto Mode

Other Shooting Modes

P Mode

Tv, Av, M, and C Mode

Playback Mode

Wireless Features

Setting Menu

Accessories

Appendix

Index



Returning the Wireless Settings to Default

Return the wireless settings to default if you transfer ownership of the camera to another person, or dispose of it. Resetting the wireless settings will also clear all Web service settings. Be sure that you want to reset all wireless settings before using this option.

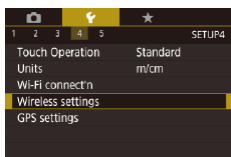

1 Choose [Wireless settings].

- Press the [MENU] button and choose [Wireless settings] on the [4] tab (131).

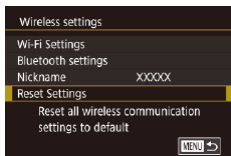

2 Choose [Reset Settings].

- Press the [▲][▼] buttons or turn the [DIAL] dial to choose [Reset Settings], and then press the [OK] button.

3 Restore the default settings.

- Press the [◀][▶] buttons or turn the [DIAL] dial to choose [OK], and then press the [OK] button.
- The wireless settings are now reset.



- To reset settings other than wireless settings to defaults, choose [Reset camera] on the [5] tab (177).

Clearing Information of Devices Paired via Bluetooth

Before pairing with a different smartphone, clear the information about any connected smartphones.

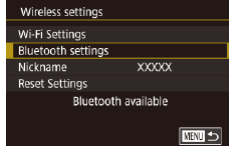

1 Choose [Bluetooth settings].

- Press the [MENU] button and choose [4] tab > [Wireless settings] > [Bluetooth settings].

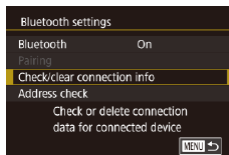

2 Choose [Check/clear connection info].

- Press the [▲][▼] buttons or turn the [DIAL] dial to choose [Check/clear connection info], and then press the [OK] button.

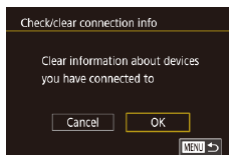

3 Clear the information.

- On the [Check/clear connection info] screen, press the [OK] button.
- After [Clear information about devices you have connected to] is displayed, press the [◀][▶] buttons or turn the [DIAL] dial to choose [OK], and then press the [OK] button.

4 Clear the camera information.

- In the Bluetooth setting menu on the smartphone, clear the camera information registered on the smartphone.



Before Use

Basic Guide

Advanced Guide

Camera Basics

Auto Mode / Hybrid Auto Mode

Other Shooting Modes

P Mode

Tv, Av, M, and C Mode

Playback Mode

Wireless Features

Setting Menu

Accessories

Appendix

Index



Setting Menu

Customize or adjust basic camera functions for greater convenience

Adjusting Basic Camera Functions

MENU (📖31) settings on the [👉1], [👉2], [👉3], [👉4], and [👉5] tabs can be configured. Customize commonly used functions as desired, for greater convenience.

Date-Based Image Storage

Instead of saving images in folders created each month, you can have the camera create folders each day you shoot to store shots taken that day.

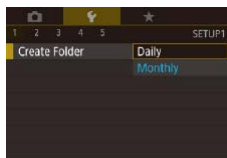

- Choose [Create Folder] on the [👉1] tab, and then choose [Daily].
- Images will now be saved in folders created on the shooting date.

File Numbering

Your shots are automatically numbered in sequential order (0001 – 9999) and saved in folders that store up to 2,000 images each. You can change how the camera assigns file numbers.

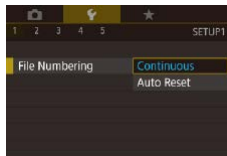

- Choose [File Numbering] on the [👉1] tab, and then choose the desired option.

Continuous	Images are numbered consecutively (until the 9999th shot is taken/saved) even if you switch memory cards.
Auto Reset	Image numbering is reset to 0001 if you switch memory cards, or when a new folder is created.

Before Use

Basic Guide

Advanced Guide

Camera Basics

Auto Mode / Hybrid Auto Mode

Other Shooting Modes

P Mode

Tv, Av, M, and C Mode

Playback Mode

Wireless Features

Setting Menu

Accessories

Appendix

Index





- Regardless of the option selected in this setting, shots may be numbered consecutively after the last number of existing images on newly inserted memory cards. To start saving shots from 0001, use an empty (or formatted, [171](#)) memory card.

Formatting Memory Cards

Before using a new memory card or a card formatted in another device, you should format the card with this camera. Formatting erases all data on a memory card. Before formatting, copy images on the memory card to a computer, or take other steps to back them up.

1 Access the [Format] screen.

- Choose [Format] on the [1](#) tab, and then press the [171](#) button.

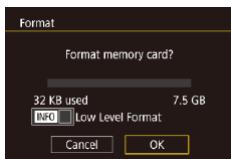

2 Choose [OK].

- Press the [171](#) buttons or turn the [171](#) dial to choose [OK], and then press the [171](#) button.

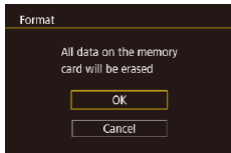

3 Format the memory card.

- Press the [171](#) buttons or turn the [171](#) dial to choose [OK] after the confirmation message, and then press the [171](#) button to start formatting.
- When formatting is finished, [Memory card formatting complete] is displayed. Press the [171](#) button.



- Formatting or erasing data on a memory card only changes file management information on the card and does not erase the data completely. When transferring or disposing of memory cards, take steps to protect personal information if necessary, as by physically destroying cards.



- The total card capacity indicated on the formatting screen may be less than the advertised capacity.

Low-Level Formatting

Perform low-level formatting in the following cases: [Memory card error] is displayed, the camera is not working correctly, card image reading/writing is slower, continuous shooting is slower, or movie recording suddenly stops. Low-level formatting erases all data on a memory card. Before low-level formatting, copy images on the memory card to a computer, or take other steps to back them up.

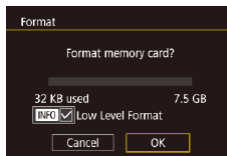

- On the screen in step 2 of “Formatting Memory Cards” ([171](#)), press the [171](#) button to choose [Low Level Format]. A [171](#) icon is displayed.
- Follow step 2 in “Formatting Memory Cards” ([171](#)) to continue with the formatting process.



- Low-level formatting takes longer than “Formatting Memory Cards” ([171](#)), because data is erased from all storage regions of the memory card.
- You can cancel low-level formatting in progress by choosing [Stop]. In this case, all data will be erased, but the memory card can be used normally.

Before Use

Basic Guide

Advanced Guide

Camera Basics

Auto Mode /
Hybrid Auto Mode

Other Shooting Modes

P Mode

Tv, Av, M, and C Mode

Playback Mode

Wireless Features

Setting Menu

Accessories

Appendix

Index



Changing the Video System

Set the video system of any television used for display. This setting determines the image quality (frame rate) available for movies.

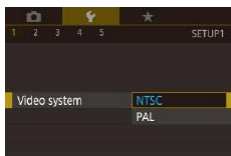

- Choose [Video system] on the [1] tab, and then choose an option.

Electronic Level Calibration

Calibrate the electronic level if it seems ineffective in helping you level the camera.

For greater calibration accuracy, display grid lines (📖103) to help you level the camera in advance.

1 Make sure the camera is level.

- Place the camera on a flat surface, such as a table.

2 Calibrate the electronic level.

- Choose [Electronic level] on the [1] tab, and then press the [OK] button.
- To adjust left/right tilt, choose [Horizontal Roll Calibration], and to adjust forward/backward tilt, choose [Vertical Pitch Calibration], followed by the [OK] button. A confirmation message is displayed.
- Choose [OK], and then press the [OK] button.

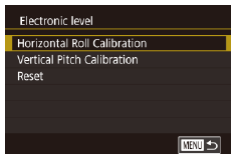

Resetting the Electronic Level

Restore the electronic level to its original state as follows. Note that this is not possible unless you have calibrated the electronic level.

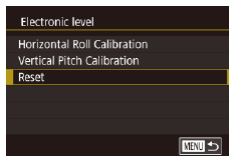

- Choose [Electronic level] on the [1] tab, and then press the [OK] button.
- Choose [Reset], and then press the [OK] button.
- Choose [OK], and then press the [OK] button.

Switching the Color of Screen Information

▶ Still Images ▶ Movies

Information displayed on the screen and menus can be changed to a color suitable for shooting under low-light conditions. Enabling this setting is useful in modes such as 📷 (📖67).

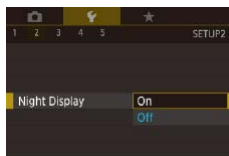

- Choose [Night Display] on the [2] tab, and then choose [On] (📖31).
- To restore the original display, choose [Off].



- You can also return the setting to [Off] by holding down the [▼] button for at least one second.

Before Use

Basic Guide

Advanced Guide

Camera Basics

Auto Mode /
Hybrid Auto Mode

Other Shooting Modes

P Mode

Tv, Av, M, and C Mode

Playback Mode

Wireless Features

Setting Menu

Accessories

Appendix

Index



Using Eco Mode

This function allows you to conserve battery power in Shooting mode. When the camera is not in use, the screen quickly darkens to reduce battery consumption.

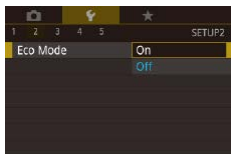

1 Configure the setting.

- Choose [Eco Mode] on the [F2] tab, and then choose [On].
- [ECO] is now shown on the shooting screen (204).
- The screen darkens when the camera is not used for approximately two seconds; approximately ten seconds after darkening, the screen turns off. The camera turns off after approximately three minutes of inactivity.

2 Shoot.

- To activate the screen and prepare for shooting when the screen is off but the lens is still out, press the shutter button halfway.

Power-Saving Adjustment

Adjust the timing of automatic deactivation of the camera, screen, and viewfinder (Auto Power Down, Display Off, and Viewfinder Off (27)).

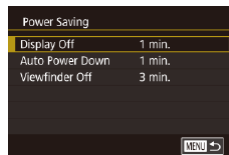

- Choose [Power Saving] on the [F2] tab, and then press the [MENU] button.
- Choose an item, press the [OK] button, and then press the [▲][▼] buttons or turn the [DIAL] dial to configure the setting.



- [Display Off] and [Auto Power Down] cannot be configured when Eco Mode (173) is set to [On].

Screen Brightness

Screen and viewfinder brightness can be set separately. Before adjustment, make sure the display to adjust is activated.



- Choose [F2] tab > [Disp. Brightness], press the [OK] button, and then press the [◀][▶] buttons or turn the [DIAL] dial to adjust the brightness.



- For maximum brightness, press and hold the [▼] button for at least one second. (This will override the [Disp. Brightness] setting on the [F2] tab.) To restore the original brightness, press and hold the [▼] button again for at least one second or restart the camera.

Before Use

Basic Guide

Advanced Guide

Camera Basics

Auto Mode /
Hybrid Auto Mode

Other Shooting Modes

P Mode

Tv, Av, M, and C Mode

Playback Mode

Wireless Features

Setting Menu

Accessories

Appendix

Index



World Clock

To ensure that your shots will have the correct local date and time when you travel abroad, simply register the destination in advance and switch to that time zone. This convenient feature eliminates the need to change the Date/Time setting manually.

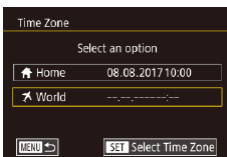
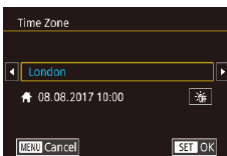
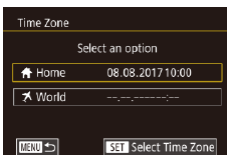

1 Specify your home time zone.

- Choose [Time Zone] on the [F2] tab, and then press the [SET] button.
- When configuring this setting for the first time, make sure [Home] is selected, and then press the [SET] button.
- Press the [◀][▶] buttons to choose your home time zone.
- To set daylight saving time (1 hour ahead), choose [Off] by pressing the [▲][▼] buttons or turning the [DISP] dial, and then choose [On] by pressing the [◀][▶] buttons.
- Press the [SET] button.

2 Specify your destination.

- Press the [▲][▼] buttons or turn the [DISP] dial to choose [World], and then press the [SET] button.
- Press the [◀][▶] buttons to choose the destination.
- If necessary, specify daylight saving time as in step 1.
- Press the [SET] button.

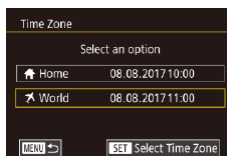

3 Switch to the destination time zone.

- Press the [▲][▼] buttons or turn the [DISP] dial to choose [World], and then press the [MENU] button.
- [World] is now shown on [Time Zone] and shooting screens (P204).



- Adjusting the date or time while in [World] mode (P22) will automatically update your [Home] time and date.

Date and Time

Adjust the date and time as follows.

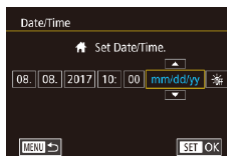

- Choose [Date/Time] on the [F2] tab, and then press the [SET] button.
- Press the [◀][▶] buttons to choose an item, and then adjust the setting, either by pressing the [▲][▼] buttons or turning the [DISP] dial.

Lens Retraction Timing

The lens is normally retracted for safety about one minute after you press the [▶] button in Shooting mode (P26). To have the lens retracted immediately after you press the [▶] button, set the retraction timing to [0 sec.].

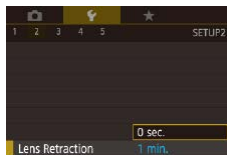

- Choose [Lens Retraction] on the [F2] tab, and then choose [0 sec.].

Before Use

Basic Guide

Advanced Guide

Camera Basics

Auto Mode / Hybrid Auto Mode

Other Shooting Modes

P Mode

Tv, Av, M, and C Mode

Playback Mode

Wireless Features

Setting Menu

Accessories

Appendix

Index



Display Language

Change the display language as needed.



- Choose [Language] on the [F3] tab, and then press the [SET] button.
- Press the [▲][▼][◀][▶] buttons or turn the [DISP] dial to choose a language, and then press the [SET] button.



- You can also access the [Language] screen in Playback mode by pressing and holding the [SET] button and immediately pressing the [MENU] button.

Silencing Camera Operations

Silence camera sounds and movies as follows.

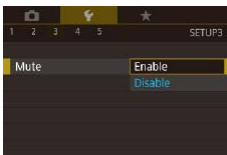

- Choose [Mute] on the [F3] tab, and then choose [Enable].



- Operation can also be silenced by holding down the [MENU] button as you turn the camera on.
- Sound is not played during movies (111) if you mute camera sounds. To restore sound during movies, press the [▲] button or drag up across the screen. Adjust volume as needed by pressing the [▲][▼] buttons or by dragging up or down quickly.

Adjusting the Volume

Adjust the volume of individual camera sounds as follows.

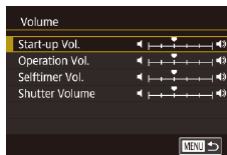

- Choose [Volume] on the [F3] tab, and then press the [SET] button.
- Press the [▲][▼] buttons or turn the [DISP] dial to choose an option, press the [SET] button, and then press the [◀][▶] buttons to adjust the volume.

Customizing Sounds

Customize camera operating sounds as follows.

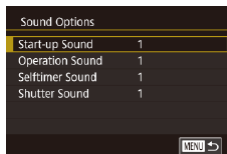

- Choose [Sound Options] on the [F3] tab, and then press the [SET] button.
- Press the [▲][▼] buttons or turn the [DISP] dial to choose an option, press the [SET] button, and then press the [▲][▼] buttons to change the sound.



- The shutter sound in digest movies recorded in [L] mode (137) cannot be changed.

Start-Up Screen

Customize the start-up screen shown after you turn the camera on as follows.

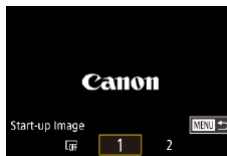

- Choose [Start-up Image] on the [F1] tab, and then press the [SET] button.
- Press the [◀][▶] buttons or turn the [DISP] dial to choose an option.

Before Use

Basic Guide

Advanced Guide

Camera Basics

Auto Mode / Hybrid Auto Mode

Other Shooting Modes

P Mode

Tv, Av, M, and C Mode

Playback Mode

Wireless Features

Setting Menu

Accessories

Appendix

Index



Hiding Hints and Tips

Hints and tips are normally shown when you choose Quick Set menu (📖30) items. If you prefer, you can deactivate this information.

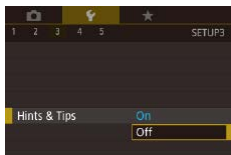

- Choose [Hints & Tips] on the [🔧3] tab, and then choose [Off].

Listing Shooting Modes by Icon

List shooting modes on the selection screen by icon only, without mode names, for faster selection.

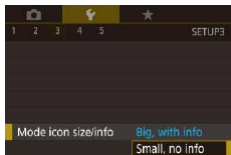

- Choose [Mode icon size/info] on the [🔧3] tab, and then choose [Small, no info].

Adjusting the Touch-Screen Panel

Sensitivity of the touch-screen panel can be increased to respond to a lighter touch, or you can disable touch control.

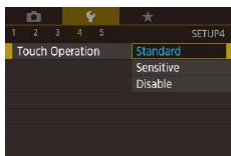

- Choose [🔧4] tab > [Touch Operation], and then choose the desired option.
- To increase touch-screen panel sensitivity, choose [Sensitive], and to disable touch control, choose [Disable].

Metric / Non-Metric Display

Change the unit of measurement shown in the zoom bar (📖35), the MF indicator (📖89), and elsewhere from m/cm to ft/in as needed.

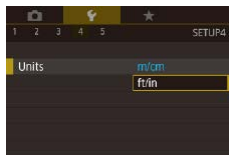

- Choose [Units] on the [🔧4] tab, and then choose [ft/in].

Checking Certification Logos

Some logos for certification requirements met by the camera can be viewed on the screen. Other certification logos are printed in this guide, on the camera packaging, or on the camera body.

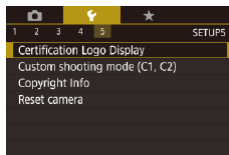

- Choose [Certification Logo Display] on the [🔧5] tab, and then press the [📖] button.

Before Use

Basic Guide

Advanced Guide

Camera Basics

Auto Mode /
Hybrid Auto Mode

Other Shooting Modes

P Mode

Tv, Av, M, and C Mode

Playback Mode

Wireless Features

Setting Menu

Accessories

Appendix

Index



Setting Copyright Information to Record in Images

To record the author's name and copyright details in images, set this information beforehand as follows.

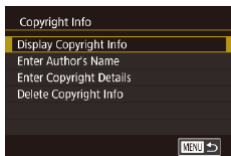

- Choose [Copyright Info] on the [F5] tab, and then press the [OK] button.
- Press the [▲][▼] buttons or turn the [DIAL] dial to choose [Enter Author's Name] or [Enter Copyright Details]. Press the [OK] button to access the keyboard, and enter the name (p. 32).
- Press the [MENU] button. When [Accept changes?] is displayed, choose [Yes] (either press the [◀][▶] buttons or turn the [DIAL] dial), and then press the [OK] button.
- The information set here will now be recorded in images.



- To check the information entered, choose [Display Copyright Info] on the screen above, and then press the [OK] button.

Deleting All Copyright Information

You can delete both the author's name and copyright details at the same time as follows.

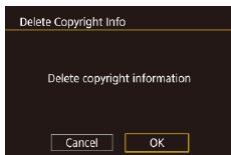

- Follow the steps in "Setting Copyright Information to Record in Images" (p. 177) and choose [Delete Copyright Info].
- Press the [◀][▶] buttons or turn the [DIAL] dial to choose [OK], and then press the [OK] button.



- The copyright info already recorded in images will not be deleted.

Adjusting Other Settings

The following settings can also be adjusted.

- [Wi-Fi connect'n] ([F4] tab) (p. 141)
- [Wireless settings] ([F4] tab) (p. 141)
- [GPS settings] ([F4] tab) (p. 164)
- [Custom shooting mode (C1, C2)] ([F5] tab) (p. 108)

Restoring Default Camera Settings

If you accidentally change a setting, you can restore default camera settings.

Restoring All Camera Defaults

1 Access the [Basic settings] screen.

- Choose [Reset camera] on the [F5] tab, and then press the [OK] button.
- Choose [Basic settings], and then press the [OK] button.

2 Restore default settings.

- Press the [◀][▶] buttons or turn the [DIAL] dial to choose [OK], and then press the [OK] button.
- All camera defaults are now restored.

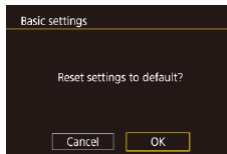

Before Use

Basic Guide

Advanced Guide

Camera Basics

Auto Mode /
Hybrid Auto Mode

Other Shooting Modes

P Mode

Tv, Av, M, and C Mode

Playback Mode

Wireless Features

Setting Menu

Accessories

Appendix

Index





- The following functions are not restored to default settings.
 - [Y1] tab setting [Video system] (📖172)
 - [Y2] tab settings [Time Zone] (📖174) and [Date/Time] (📖174)
 - [Y3] tab setting [Language] (📖175)
 - Shooting mode (📖56)
 - Exposure compensation (📖78) setting
 - Wireless settings (📖141)
 - Calibrated value for the electronic level (📖172)
 - Copyright information (📖177)
 - Face ID information (📖45)

Restoring Defaults for Individual Functions

Settings for the following functions can be restored to defaults individually.

- User settings for custom shooting modes
- Copyright information
- Calibrated value for the electronic level
- Face ID information
- Wireless settings

1 Access the [Other settings] screen.

- Choose [Reset camera] on the [Y5] tab, and then press the [OK] button.
- Press the [▲][▼] buttons or turn the [DISP] dial to choose [Other settings], and then press the [OK] button.

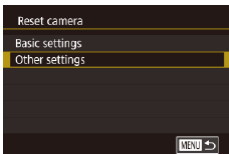

2 Choose the function to reset.

- Press the [▲][▼] buttons or turn the [DISP] dial to choose the function to reset, and then press the [OK] button.

3 Restore default settings.

- Press the [◀][▶] buttons or turn the [DISP] dial to choose [OK], and then press the [OK] button.
- Default function settings are now restored.

Before Use

Basic Guide

Advanced Guide

Camera Basics

Auto Mode /
Hybrid Auto Mode

Other Shooting Modes

P Mode

Tv, Av, M, and C Mode

Playback Mode

Wireless Features

Setting Menu

Accessories

Appendix

Index



Accessories

Enjoy the camera in more ways with optional Canon accessories and other compatible accessories sold separately

Use of genuine Canon accessories is recommended.

This product is designed to achieve excellent performance when used with genuine Canon accessories. Canon shall not be liable for any damage to this product and/or accidents such as fire, etc., caused by the malfunction of non-genuine Canon accessories (e.g., a leakage and/or explosion of a battery pack). Please note that any repairs your Canon product may require as a result of such malfunction are not covered under warranty and will incur a fee.

Before Use

Basic Guide

Advanced Guide

Camera Basics

Auto Mode /
Hybrid Auto Mode

Other Shooting Modes

P Mode

Tv, Av, M, and C Mode

Playback Mode

Wireless Features

Setting Menu

Accessories

Appendix

Index



System Map

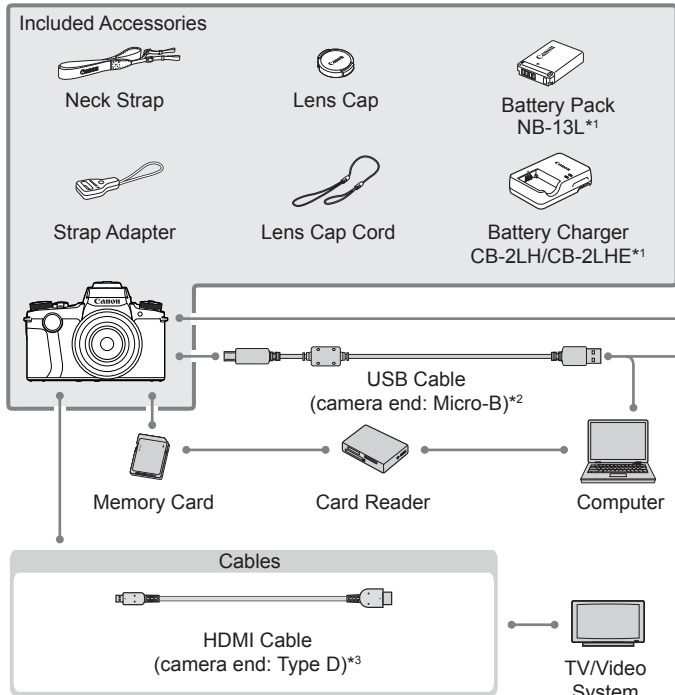

*1 Also available for purchase separately.

*2 A genuine Canon accessory is also available (Interface Cable IFC-600PCU).

*3 Use a commercially available cable no longer than 2.5 m (8.2 ft.).

*4 The following accessories are also supported: Speedlite 580EX II, 580EX, 430EX, 320EX, 270EX, and 220EX, Speedlite Transmitter ST-E2 and ST-E3-RT, Speedlite Bracket SB-E2, and Off-Camera Shoe Cord OC-E3.

*5 Requires Remote Controller Adapter RA-E3.

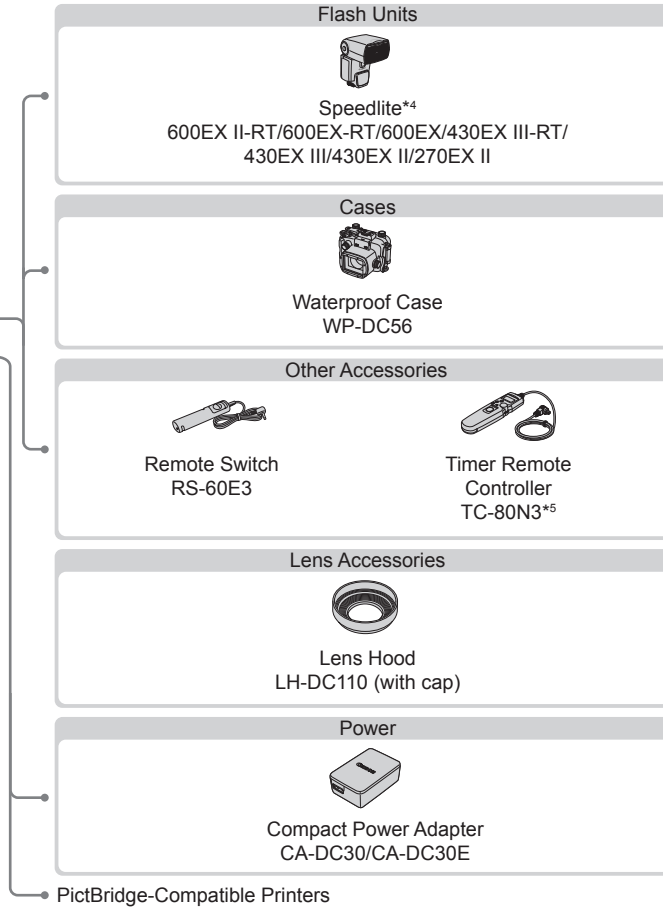

Before Use

Basic Guide

Advanced Guide

Camera Basics

Auto Mode /
Hybrid Auto Mode

Other Shooting Modes

P Mode

Tv, Av, M, and C Mode

Playback Mode

Wireless Features

Setting Menu

Accessories

Appendix

Index



Optional Accessories

The following camera accessories are sold separately. Note that availability varies by area, and some accessories may no longer be available.

Power Supplies

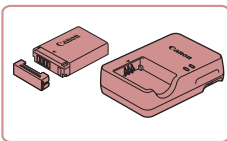

Battery Pack NB-13L

- Rechargeable lithium-ion battery

Battery Charger CB-2LH/CB-2LHE

- Charger for Battery Pack NB-13L



- The message [Battery communication error] is displayed if you use a non-genuine Canon battery pack, and user response is required. Note that Canon shall not be liable for any damages resulting from accidents, such as malfunction or fire, that occur due to use of non-genuine Canon battery packs.



- The battery pack includes a convenient cover which you can attach to know the charge status at a glance. Attach the cover so that ▲ is visible on a charged battery pack, and attach it so that ▲ is not visible on an uncharged battery pack.



Compact Power Adapter CA-DC30/ CA-DC30E

- Insert the included battery pack into the camera for charging. Interface Cable IFC-600PCU (sold separately) is required to connect the adapter to the camera.



- The battery charger and compact power adapter can be used in areas with 100 – 240 V AC power (50/60 Hz).
- For power outlets in a different format, use a commercially available adapter for the plug. Never use an electrical transformer designed for traveling, which may damage the battery pack.

Flash Units

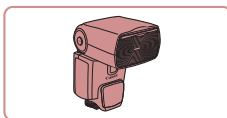

Speedlite 600EX II-RT/600EX-RT/ 600EX/430EX III-RT/430EX III/ 430EX II/270EX II

- Shoe-mounted flash unit that enables many styles of flash photography. Speedlite 580EX II, 580EX, 430EX, 320EX, 270EX, and 220EX are also supported.

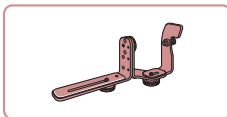

Speedlite Bracket SB-E2

- Prevents unnatural shadows next to subjects during vertical shooting. Includes Off-Camera Shoe Cord OC-E3.

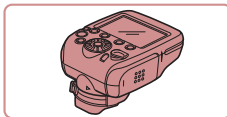

Speedlite Transmitter ST-E2/ST-E3-RT

- Enables wireless control of slave Speedlite flash units (except Speedlite 220EX/270EX).

Before Use

Basic Guide

Advanced Guide

Camera Basics

Auto Mode /
Hybrid Auto Mode

Other Shooting Modes

P Mode

Tv, Av, M, and C Mode

Playback Mode

Wireless Features

Setting Menu

Accessories

Appendix

Index



Other Accessories

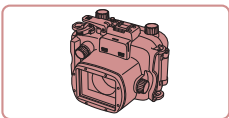

Waterproof Case WP-DC56

- For underwater photography at depths of up to 40 meters (130 ft.). Also useful for shooting in the rain, at the beach, or on ski slopes.

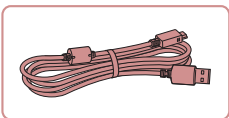

Interface Cable IFC-600PCU

- For connecting the camera to a computer or printer.

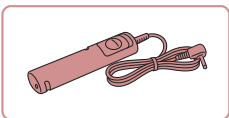

Remote Switch RS-60E3

- Enables remote shutter button operation (pressing the button halfway or all the way down).

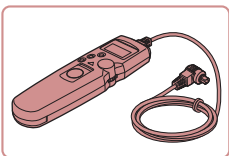

Timer Remote Controller TC-80N3

- Set a self-timer or interval timer, or control the camera in other ways. Note that Remote Controller Adapter RA-E3 (sold separately) is required in order to connect the timer remote controller to the camera.

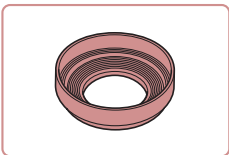

Lens Hood LH-DC110 (with cap)

- Prevents extraneous light from entering the lens and causing flares or ghosting, which reduce image quality.

Printers

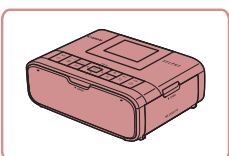

Canon-Brand PictBridge-Compatible Printers

- Even without using a computer, you can print images by connecting the camera directly to a printer. For details, visit your nearest Canon retailer.

Photo and Movie Storage

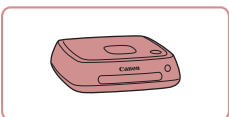

Connect Station CS100

- A media hub for storing camera images, viewing on a connected TV, printing wirelessly on a Wi-Fi-compatible printer, sharing over the Internet, and more.

Before Use

Basic Guide

Advanced Guide

Camera Basics

Auto Mode /
Hybrid Auto Mode

Other Shooting Modes

P Mode

Tv, Av, M, and C Mode

Playback Mode

Wireless Features

Setting Menu

Accessories

Appendix

Index



Using Optional Accessories

Playback on a TV

▶ Still Images ▶ Movies

You can view your shots on a TV by connecting the camera to an HDTV with a commercially available HDMI cable (not exceeding 2.5 m / 8.2 ft., with a Type D terminal on the camera end). Movies shot at an image quality of [FHD 59.94P], [FHD 29.97P], [FHD 23.98P], [FHD 29.97P], [FHD 50.00P], [FHD 25.00P], or [FHD 25.00P] can be viewed in high definition.

For details on connection or how to switch inputs, refer to the TV manual.

1 Make sure the camera and TV are off.

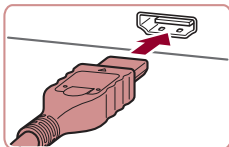

2 Connect the camera to the TV.

- On the TV, insert the cable plug fully into the HDMI input as shown.

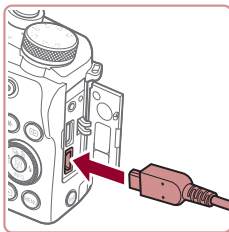

- On the camera, open the terminal cover and insert the cable plug fully into the camera terminal.

3 Turn the TV on and switch to external input.

- Switch the TV input to the external input you connected the cable to in step 2.

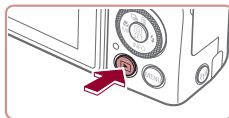

4 Turn the camera on.

- Press the [▶] button.
- Images from the camera are now displayed on the TV. (Nothing is displayed on the camera screen.)
- When finished, turn off the camera and TV before disconnecting the cable.



- Touch-screen operations are not supported while the camera is connected to a television.



- Some information may not be available when using a TV as the display (p.205).
- Camera operating sounds are not played while the camera is connected to an HDTV.

Before Use

Basic Guide

Advanced Guide

Camera Basics

Auto Mode / Hybrid Auto Mode

Other Shooting Modes

P Mode

Tv, Av, M, and C Mode

Playback Mode

Wireless Features

Setting Menu

Accessories

Appendix

Index



Charging via USB

The battery pack can be charged without removing it from the camera by using Compact Power Adapter CA-DC30/CA-DC30E and Interface Cable IFC-600PCU, both sold separately.

1 Insert the battery pack.

- Follow step 1 in “Inserting the Battery Pack and Your Memory Card” (p.20) to open the cover.
- Insert the battery pack as described in step 2 of “Inserting the Battery Pack and Your Memory Card” (p.20).
- Follow step 3 in “Inserting the Battery Pack and Your Memory Card” (p.20) to close the cover.

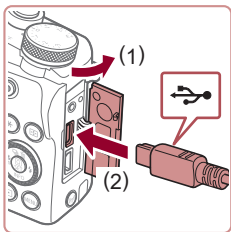

2 Connect the compact power adapter to the camera.

- With the camera turned off, open the cover (1). Hold the smaller plug of the interface cable (sold separately) facing as shown and insert the plug fully into the camera terminal (2).

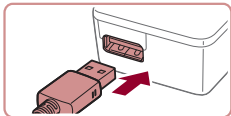

- Insert the larger plug of the interface cable into the compact power adapter.

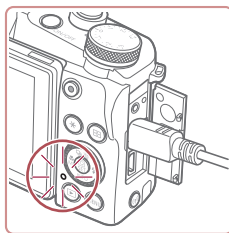
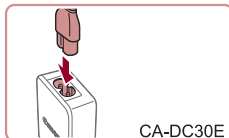
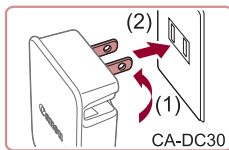

3 Charge the battery pack.

- CA-DC30: Flip out the plug (1) and plug the compact power adapter into a power outlet (2).
- CA-DC30E: Plug the power cord into the compact power adapter, then plug the other end into a power outlet.

- Charging begins and the USB charge lamp lights up.
- The lamp turns off when charging finishes.
- Remove the compact power adapter from the power outlet and the interface cable from the camera.



- To protect the battery pack and keep it in optimal condition, do not charge it continuously for more than 24 hours.
- When charging another battery pack, always disconnect the interface cable from the camera before replacing the battery pack for charging.

Before Use

Basic Guide

Advanced Guide

Camera Basics

Auto Mode /
Hybrid Auto Mode

Other Shooting Modes

P Mode

Tv, Av, M, and C Mode

Playback Mode

Wireless Features

Setting Menu

Accessories

Appendix

Index





- For details on charging time and the number of shots and recording time possible with a fully charged battery pack, see “Power” (📖225).
- You can view images even while the battery is charging, by turning the camera on and entering Playback mode (📖24). However, you cannot shoot while the battery is charging.
- Charged battery packs gradually lose their charge, even when they are not used. Charge the battery pack on (or immediately before) the day of use.
- The charger can be used in areas with 100 – 240 V AC power (50/60 Hz). For power outlets in a different format, use a commercially available adapter for the plug. Never use an electrical transformer designed for traveling, which may damage the battery pack.

Using a Computer to Charge the Battery

- You can also charge the battery pack by inserting the larger plug of the interface cable into a computer’s USB terminal in step 2 of “Charging via USB” (📖184). For details about USB connections on the computer, refer to the computer user manual.
- When charging is finished, the indicator on the back of the camera blinks green. However, the indicator also blinks green if the computer enters sleep or other modes and charging is interrupted.



- Charging stops and the indicator goes off if, after you begin charging, you press the power button to turn the camera off.
- With some computers, battery charging may require the memory card to be in the camera. Insert the memory card in the camera (📖20) before connecting the cable to the computer’s USB port.

Using a Lens Hood (Sold Separately)

▶ Still Images ▶ Movies

To reduce the amount of extraneous light entering the lens, you can attach optional Lens Hood LH-DC110.

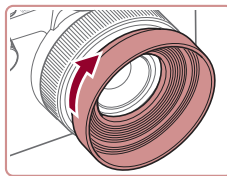

- Make sure the camera is off.
- Align the lens hood threads with the camera threads and turn the lens hood in the direction shown.
- Make sure not to attach the lens hood too tightly. Doing so could prevent removal of the lens hood and damage the camera.
- To remove the lens hood, turn it in the opposite direction.



- Vignetting may occur if you use the built-in flash when the lens hood is attached.

Before Use

Basic Guide

Advanced Guide

Camera Basics

Auto Mode /
Hybrid Auto Mode

Other Shooting Modes

P Mode

Tv, Av, M, and C Mode

Playback Mode

Wireless Features

Setting Menu

Accessories

Appendix

Index



Using a Remote Switch (Sold Separately)

▶ Still Images ▶ Movies

An optional Remote Switch RS-60E3 can be used to avoid camera shake that may otherwise occur when pressing the shutter button directly. This optional accessory is convenient when shooting at slow shutter speeds.

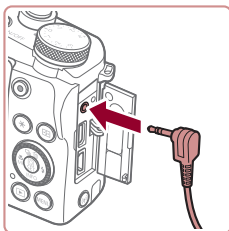

1 Connect the remote switch.

- Make sure the camera is off.
- Open the terminal cover and insert the remote switch plug.

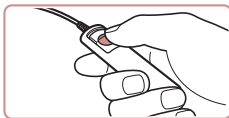

2 Shoot.

- To shoot, press the release button on the remote switch.

Using a Timer Remote Controller (Sold Separately)

▶ Still Images ▶ Movies

To set a self-timer or interval timer or control the camera in other ways, you can use optional Timer Remote Controller TC-80N3. This is convenient in time-lapse photography of blooming flowers, for example. Note that a remote controller adapter (RA-E3, sold separately) is required in order to connect the timer remote controller to the camera.



- Also refer to the TC-80N3 instruction manual for additional information.

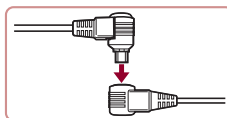

1 Connect the timer remote controller to the remote controller adapter.

- Connect the timer remote controller to the remote controller adapter as shown.

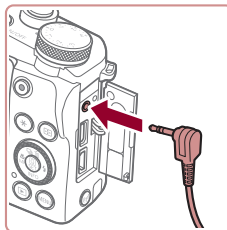

2 Connect the adapter to the camera.

- Make sure the camera is off.
- Open the terminal cover and insert the adapter plug.

3 Shoot.

- Turn the camera on.
- To shoot, operate the timer remote controller.

Before Use

Basic Guide

Advanced Guide

Camera Basics

Auto Mode /
Hybrid Auto Mode

Other Shooting Modes

P Mode

Tv, Av, M, and C Mode

Playback Mode

Wireless Features

Setting Menu

Accessories

Appendix

Index



Using an External Flash (Sold Separately)

► Still Images ► Movies

More sophisticated flash photography is possible with an optional Speedlite EX series flash. For movie shooting using an LED light, the optional Speedlite 320EX flash is available.



- This camera does not support some Speedlite EX series functions.
- Non-EX series Canon flash units may not fire correctly or may not fire at all, in some cases.
- Use of non-Canon flash units (especially high-voltage flash units) or flash accessories may prevent normal camera operation and may damage the camera.



- Also refer to the Speedlite EX series manual for additional information.

Speedlite EX Series

► Still Images ► Movies

These optional flash units can provide bright lighting and meet a variety of flash photography needs.

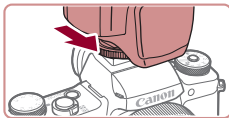

1 Attach the flash.

- Make sure the camera is off, and then attach the flash unit to the hot shoe.

2 Turn the flash on, and then turn the camera on.

- A red  icon is now displayed.
- The flash pilot lamp will light up when the flash is ready.

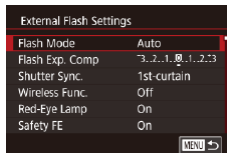

3 Choose shooting mode [P], [Tv], [Av], or [M].

- In other modes, the flash is adjusted and fired automatically, as needed.

4 Configure the external flash.

- Press the [MENU] button, choose [Flash Control] on the [5] tab, and then press the [5] button.
- Options already set on the flash itself are displayed.
- Press the [▲][▼] buttons or turn the [DISP] dial to choose an item, and then set the desired option.
- Available items vary depending on the shooting mode and the flash attached (188).



- Settings for the built-in flash cannot be configured while a Speedlite EX series flash is attached, because that setting screen is no longer accessible.
- You can also access the setting screen by pressing the [▶] button for at least one second.
- [Flash Control] is not available when the 600EX II-RT, 600EX-RT, 600EX, or 580EX II has been set up for stroboscopic flash.
- 320EX only: Auto LED lighting is only available in low-light movie recording or in Movie mode. In this case, the  icon is shown.

Before Use

Basic Guide

Advanced Guide

Camera Basics

Auto Mode /
Hybrid Auto Mode

Other Shooting Modes

P Mode

Tv, Av, M, and C Mode

Playback Mode

Wireless Features

Setting Menu

Accessories

Appendix

Index



Using Speedlite Bracket SB-E2 (Sold Separately)

▶ Still Images ▶ Movies

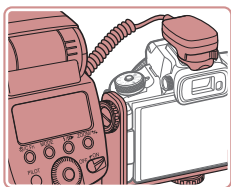

- Using the optional Speedlite Bracket SB-E2 can help prevent unnatural shadows next to subjects during vertical shooting.
- To keep the screen out of the way of the bracket, use the screen closed and facing outward.

Camera Settings Available with an External Flash (Sold Separately)

▶ Still Images ▶ Movies

The following items are available in **[P]**, **[Tv]**, **[Av]**, or **[M]** mode. In other shooting modes, only **[Red-Eye Lamp]** can be configured. (With autoflash control, the flash always fires.) However, external flash units do not fire in modes that the built-in flash does not fire (📖207).

Item	Options	Shooting Mode			
		P	Tv	Av	M
Flash Mode	Auto*1	○	○	○	○
	Manual*2	○	○	○	○
Flash Exp. Comp*3	-3 to +3	○	○	○	○
Flash Output*4	1/128*5 - 1/1 (in 1/3-stop increments)	○	○	○	○
Shutter Sync.	1st-curtain/2nd-curtain/Hi-speed	○	○	○	○
Wireless Func.*6	Off/Optical/Radio	○	○	○	○
Red-Eye Lamp	On/Off	○	○	○	○
Safety FE*7	On	○	○	○	○
	Off	○	○	○	○
Clear Flash Settings*8		○	○	○	○

- *1 E-TTL mode is used for the flash.
- *2 M mode is used for the flash.
In **[M]** shooting mode, E-TTL mode is also available for the flash. In this case, when the flash fires, flash exposure compensation set on the flash is applied to the flash output level set on the camera.
- *3 Can be configured only when **[Flash Mode]** is **[Auto]** and flash exposure compensation set on the flash is **[+0]**. When you adjust flash exposure compensation on 600EX II-RT, 600EX-RT, 600EX, 580EX II, or 430EX II Speedlites, the camera display will be updated accordingly.
- *4 Can be configured when **[Flash Mode]** is **[Manual]**. Linked to settings on the flash unit.
- *5 1/64 for Speedlite 430EX II/430EX/320EX/270EX II/270EX.
- *6 Configure other options on the flash unit itself. Available with Speedlite 600EX II-RT/600EX-RT/600EX/580EX II/90EX. When this item is not set to **[Off]**, **[Shutter Sync.]** cannot be set to **[2nd-curtain]**. (If **[Shutter Sync.]** is set to **[2nd-curtain]**, it will be changed to **[1st-curtain]**.)
- *7 Can only be configured when **[Flash Mode]** is **[Auto]**.
- *8 Restores all default settings. You can also restore defaults for **[Safety FE]** and **[Red-Eye Lamp]** from **[📷5]** tab > **[Reset camera]** > **[Basic settings]** on the camera (📖177).



- In **[AUTO]** shooting mode, icons representing Smiling, Sleeping, Babies (Smiling), Babies (Sleeping), and Children shooting scenes determined by the camera are not displayed, and the camera does not shoot continuously (📖40).

Before Use

Basic Guide

Advanced Guide

Camera Basics

Auto Mode /
Hybrid Auto Mode

Other Shooting Modes

P Mode

Tv, Av, M, and C Mode

Playback Mode

Wireless Features

Setting Menu

Accessories

Appendix

Index



Using the Software

To utilize the features of the following software, download the software from the Canon website and install it on your computer.

- CameraWindow
 - Import images to your computer
 - Add Picture Styles saved on your computer to the camera
- Image Transfer Utility
 - Set up Image Sync (📖162) and receive images
- Map Utility
 - Use a map to view GPS information that has been added to images
- Digital Photo Professional
 - Browse, process, and edit RAW images
- Picture Style Editor
 - Edit Picture Styles and create and save Picture Style files



- To view and edit movies on a computer, use preinstalled or commonly available software compatible with movies recorded by the camera.



- Image Transfer Utility can also be downloaded from the Image Sync settings page of CANON IMAGE GATEWAY.

Computer Connections via a Cable

Checking Your Computer Environment

For detailed software system requirements and compatibility information (including support in new operating systems), visit the Canon website.

Installing the Software

Install the software as described in steps 1 – 2 of “Installing CameraWindow” (📖149).

Saving Images to a Computer

Using a USB cable (sold separately; camera end: Micro-B), you can connect the camera to the computer and save images to the computer.

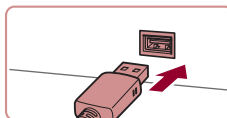
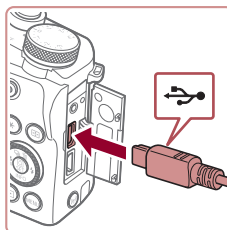

1 Connect the camera to the computer.

- With the camera turned off, open the cover. With the smaller plug of the cable in the orientation shown, insert the plug fully into the camera terminal.

- Connect the larger cable plug to the computer. For details on computer connections, refer to the computer user manual.

2 Display CameraWindow.

- Mac OS: CameraWindow is displayed when a connection is established between the camera and computer.

Before Use

Basic Guide

Advanced Guide

Camera Basics

Auto Mode /
Hybrid Auto Mode

Other Shooting Modes

P Mode

Tv, Av, M, and C Mode

Playback Mode

Wireless Features

Setting Menu

Accessories

Appendix

Index



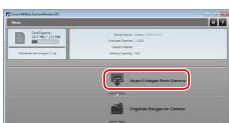
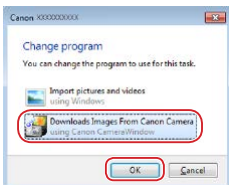



- Windows: Follow the steps introduced below.
- On the screen displayed, click the change program link of [].
- Choose [Downloads Images From Canon Camera] and then click [OK].

- Double-click [].

3 Save the images to the computer.

- Click [Import Images from Camera], and then click [Import Untransferred Images].
- Images are now saved to the Pictures folder on the computer, in separate folders named by date.
- After images are saved, close CameraWindow, press the [] button to turn the camera off, and unplug the cable.
- To view images you save to a computer, use preinstalled or commonly available software compatible with images captured by the camera.



- Windows 7: If the screen in step 2 is not displayed, click the  icon in the taskbar.
- Mac OS: If CameraWindow is not displayed after step 2, click the [CameraWindow] icon in the Dock.
- Although you can save images to a computer simply by connecting your camera to the computer without using the software, the following limitations apply.
 - It may take a few minutes after you connect the camera to the computer until camera images are accessible.
 - Images shot in vertical orientation may be saved in horizontal orientation.
 - RAW images (or JPEG images recorded with RAW images) may not be saved.
 - Image protection settings may be cleared from images saved to a computer.
 - Some problems may occur when saving images or image information, depending on the operating system version, the software in use, or image file sizes.

Before Use

Basic Guide

Advanced Guide

Camera Basics

Auto Mode /
Hybrid Auto Mode

Other Shooting Modes

P Mode

Tv, Av, M, and C Mode

Playback Mode

Wireless Features

Setting Menu

Accessories

Appendix

Index



Printing Images

▶ Still Images ▶ Movies

Print your shots and configure a variety of settings used for your printer or photo printing services by connecting the camera to a PictBridge-compatible printer with a cable.

A Canon SELPHY CP printer is used in this example of PictBridge printing. Also refer to your printer user manual.

Easy Print

▶ Still Images ▶ Movies

Print your shots by connecting the camera to a PictBridge-compatible printer with a USB cable (sold separately; camera end: Micro-B).

1 Make sure the camera and printer are off.

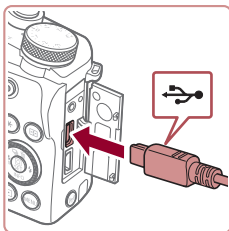

2 Connect the camera to the printer.

- Open the terminal cover and insert the smaller plug fully into the camera terminal in the orientation shown.
- Connect the larger cable plug to the printer. For other connection details, refer to the printer manual.

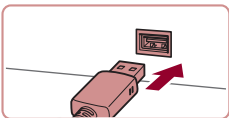

3 Turn the printer on.

4 Choose an image.

- Press the [◀][▶] buttons or turn the [DISP.] dial to choose an image.

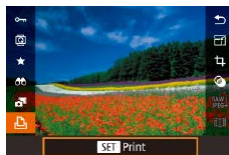

5 Access the printing screen.

- Press the [DISP.] button, choose [Print], and press the [DISP.] button again.

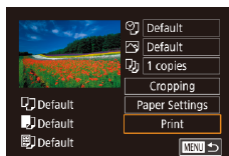

6 Print the image.

- Press the [▲][▼] buttons or turn the [DISP.] dial to choose [Print], and then press the [DISP.] button.
- Printing now begins.
- To print other images, repeat the above procedures starting from step 4 after printing is finished.
- When you are finished printing, turn the camera and printer off and disconnect the cable.



- For Canon-brand PictBridge-compatible printers (sold separately), see "Printers" (p.182).

Before Use

Basic Guide

Advanced Guide

Camera Basics

Auto Mode /
Hybrid Auto Mode

Other Shooting Modes

P Mode

Tv, Av, M, and C Mode

Playback Mode

Wireless Features

Setting Menu

Accessories

Appendix

Index



Configuring Print Settings

▶ Still Images ▶ Movies

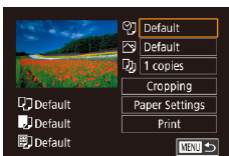

1 Access the printing screen.

- Follow steps 1 – 5 in “Easy Print” (📖 191) to access this screen.

2 Configure the settings.

- Press the [▲][▼] buttons or turn the [DISP] dial to choose an item, and then press the [SET] button. On the next screen, choose an option (either press the [▲][▼] buttons or turn the [DISP] dial), and then press the [SET] button to return to the printing screen.

🗨️	Default	Matches current printer settings.
	Date	Prints images with the date added.
	File No.	Prints images with the file number added.
	Both	Prints images with both the date and file number added.
	Off	–
🖨️	Default	Matches current printer settings.
	Off	–
	On	Uses information from the time of shooting to print under optimal settings.
	Red-Eye 1	Corrects red-eye.
📄	No. of Copies	Choose the number of copies to print.
Cropping	–	Specify a desired image area to print (📖 192).
Paper Settings	–	Specify the paper size, layout, and other details (📖 193).

Cropping Images before Printing

▶ Still Images ▶ Movies

By cropping images before printing, you can print a desired image area instead of the entire image.

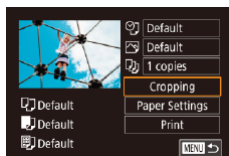

1 Choose [Cropping].

- After following step 1 in “Configuring Print Settings” (📖 192) to access the printing screen, choose [Cropping] and press the [SET] button.
- A cropping frame is now displayed, indicating the image area to print.

2 Adjust the cropping frame as needed.

- To resize the frame, move the zoom lever.
- To move the frame, press the [▲][▼][▶][◀] buttons.
- To rotate the frame, turn the [DISP] dial.
- When finished, press the [SET] button.

3 Print the image.

- Follow step 6 in “Easy Print” (📖 191) to print.



- Cropping may not be possible at small image sizes, or at some aspect ratios.

Before Use

Basic Guide

Advanced Guide

Camera Basics

Auto Mode / Hybrid Auto Mode

Other Shooting Modes

P Mode

Tv, Av, M, and C Mode

Playback Mode

Wireless Features

Setting Menu

Accessories

Appendix

Index



Choosing Paper Size and Layout before Printing

► Still Images ► Movies

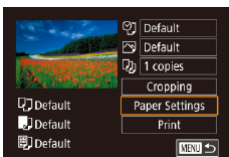

1 Choose [Paper Settings].

- After following step 1 in “Configuring Print Settings” (📖 192) to access the printing screen, choose [Paper Settings] and press the [OK] button.

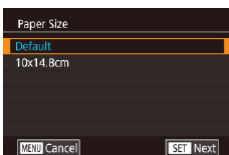

2 Choose a paper size.

- Press the [▲][▼] buttons or turn the [DISP] dial to choose an option, and then press the [OK] button.

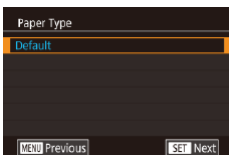

3 Choose a type of paper.

- Press the [▲][▼] buttons or turn the [DISP] dial to choose an option, and then press the [OK] button.

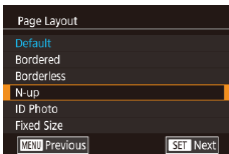

4 Choose a layout.

- Press the [▲][▼] buttons or turn the [DISP] dial to choose an option.
- When choosing [N-up], press the [OK] button. On the next screen, choose the number of images per sheet (either press the [▲][▼] buttons or turn the [DISP] dial), and then press the [OK] button.

5 Print the image.

- Follow step 6 in “Easy Print” (📖 191) to print.

Available Layout Options

Default	Matches current printer settings.
Bordered	Prints with blank space around the image.
Borderless	Borderless, edge-to-edge printing.
N-up	Choose how many images to print per sheet.
ID Photo	Prints images for identification purposes. Only available for images with a recording pixel setting of L and an aspect ratio of 3:2.
Fixed Size	Choose the print size. Choose from 3.5 x 5 in., postcard, or wide-format prints.

Printing ID Photos

► Still Images ► Movies

1 Choose [ID Photo].

- Following steps 1 – 4 in “Choosing Paper Size and Layout before Printing” (📖 193), choose [ID Photo] and press the [OK] button.

2 Choose the long and short side length.

- Press the [▲][▼] buttons or turn the [DISP] dial to choose an item, and then press the [OK] button. On the next screen, choose the length (either press the [▲][▼] buttons or turn the [DISP] dial), and then press the [OK] button.



Before Use

Basic Guide

Advanced Guide

Camera Basics

Auto Mode /
Hybrid Auto Mode

Other Shooting Modes

P Mode

Tv, Av, M, and C Mode

Playback Mode

Wireless Features

Setting Menu

Accessories

Appendix

Index





3 Choose the printing area.

- Press the [▲][▼] buttons or turn the [DISP] dial to choose [Cropping], and then press the [SET] button.
- Follow step 2 in “Cropping Images before Printing” (📖 192) to choose the printing area.

4 Print the image.

- Follow step 6 in “Easy Print” (📖 191) to print.

■ Printing Movie Scenes

▶ Still Images ▶ Movies

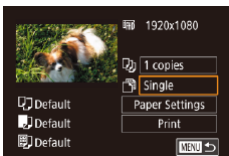

1 Access the printing screen.

- Follow steps 1 – 6 in “Easy Print” (📖 191) to choose a movie. The screen at left is displayed.

2 Choose a printing method.

- Press the [▲][▼] buttons to choose [Print], and then press the [SET] button. On the next screen, choose an option (either press the [▲][▼] buttons or turn the [DISP] dial), and then press the [SET] button to return to the printing screen.

3 Print the image.

- Follow step 6 in “Easy Print” (📖 191) to print.

Movie Printing Options

Single	Prints the current scene as a still image.
Sequence	Prints a series of scenes, a certain interval apart, on a single sheet of paper. You can also print the folder number, file number, and elapsed time for the frame by setting [Caption] to [On].



- To cancel printing in progress, press the [SET] button, choose [OK], and then press the [DISP] button again.
- After displaying a scene to print as described in steps 2 – 5 of “Playback” (📖 111), you can also access the screen in step 1 here by pressing the [◀][▶] buttons to choose [Print] in the movie control panel and then pressing the [SET] button.

■ Adding Images to the Print List (DPOF)

▶ Still Images ▶ Movies

Batch printing (📖 196) and ordering prints from a photo development service can be set up on the camera. Choose up to 998 images on a memory card and configure relevant settings, such as the number of copies, as follows. The printing information you prepare this way will conform to DPOF (Digital Print Order Format) standards.



- RAW images cannot be included in print list.

Before Use

Basic Guide

Advanced Guide

Camera Basics

Auto Mode / Hybrid Auto Mode

Other Shooting Modes

P Mode

Tv, Av, M, and C Mode

Playback Mode

Wireless Features

Setting Menu

Accessories

Appendix

Index



Configuring Print Settings

► Still Images ► Movies

Specify the printing format, whether to add the date or file number, and other settings as follows. These settings apply to all images in the print list.

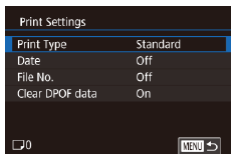

- Press the [MENU] button, choose [Print settings] on the [▶4] tab, and then press the [OK] button.
- Press the [▲][▼] buttons or turn the [DISP] dial to choose [Print Settings], and then press the [OK] button. On the next screen, choose and configure items as needed (p.31).

Print Type	Standard	One image is printed per sheet.
	Index	Smaller versions of multiple images are printed per sheet.
	Both	Both standard and index formats are printed.
Date	On	Images are printed with the shooting date.
	Off	–
File No.	On	Images are printed with the file number.
	Off	–
Clear DPOF data	On	All image print list settings are cleared after printing.
	Off	–



- Not all of your DPOF settings may be applied in printing by the printer or photo development service, in some cases.
- [!] may be displayed on the camera to warn you that the memory card has print settings that were configured on another camera. Changing the print settings using this camera may overwrite all previous settings.



- Specifying [Index] will prevent you from choosing [On] for both [Date] and [File No.] at the same time.
- Index printing is not available on some Canon-brand PictBridge-compatible printers (sold separately).
- The date is printed in a format matching setting details in [Date/Time] on the [▶2] tab (p.22).

Setting Up Printing for Individual Images

► Still Images ► Movies

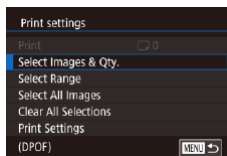

1 Choose [Select Images & Qty.].

- Press the [MENU] button, choose [Print settings] on the [▶4] tab, and then press the [OK] button.
- Press the [▲][▼] buttons or turn the [DISP] dial to choose [Select Images & Qty.], and then press the [OK] button (p.31).

2 Choose an image.

- Press the [◀][▶] buttons or turn the [DISP] dial to choose an image, and then press the [OK] button.
- If you specify index printing for the image, it is labeled with a [✓] icon. To cancel index printing for the image, press the [OK] button again. [✓] is no longer displayed.

Before Use

Basic Guide

Advanced Guide

Camera Basics

Auto Mode / Hybrid Auto Mode

Other Shooting Modes

P Mode

Tv, Av, M, and C Mode

Playback Mode

Wireless Features

Setting Menu

Accessories

Appendix

Index





3 Specify the number of prints.

- Press the [▲][▼] buttons or turn the [DISP] dial to specify the number of prints (up to 99).
- To set up printing for other images and specify the number of prints, repeat steps 2 – 3.
- When finished, press the [MENU] button to return to the menu screen.

Setting Up Printing for a Range of Images

▶ Still Images ▶ Movies

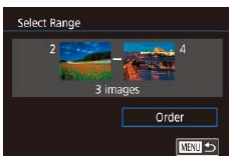

- Following step 1 in “Setting Up Printing for Individual Images” (📖 195), choose [Select Range] and press the [DISP] button.
- Follow steps 2 – 3 in “Selecting a Range” (📖 122) to specify images.
- Press the [▲][▼] buttons to choose [Order], and then press the [DISP] button.

Setting Up Printing for All Images

▶ Still Images ▶ Movies

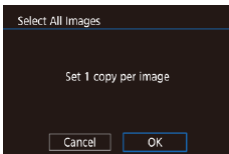

- Following step 1 in “Setting Up Printing for Individual Images” (📖 195), choose [Select All Images] and press the [DISP] button.
- Press the [◀][▶] buttons or turn the [DISP] dial to choose [OK], and then press the [DISP] button.

Clearing All Images from the Print List

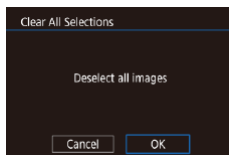

- Following step 1 in “Setting Up Printing for Individual Images” (📖 195), choose [Clear All Selections] and press the [DISP] button.
- Press the [◀][▶] buttons or turn the [DISP] dial to choose [OK], and then press the [DISP] button.

Printing Images Added to the Print List (DPOF)

▶ Still Images ▶ Movies

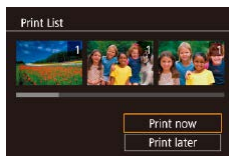

- When images have been added to the print list (📖 194 – 📖 196), this screen is displayed after you connect the camera to a PictBridge-compatible printer. Press the [▲][▼] buttons to choose [Print now], and then simply press the [DISP] button to print the images in the print list.
- Any DPOF print job that you temporarily stop will be resumed from the next image.

Before Use

Basic Guide

Advanced Guide

Camera Basics

Auto Mode /
Hybrid Auto Mode

Other Shooting Modes

P Mode

Tv, Av, M, and C Mode

Playback Mode

Wireless Features

Setting Menu

Accessories

Appendix

Index



Adding Images to a Photobook

▶ Still Images ▶ Movies

Photobooks can be set up on the camera by choosing up to 998 images on a memory card and using CameraWindow to import them to your computer (189), where they are copied to their own folder. This is convenient when ordering printed photobooks online or printing photobooks with your own printer.

Choosing a Selection Method

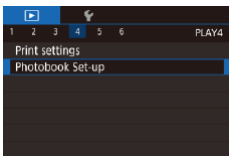

- Press the [MENU] button, choose [Photobook Set-up] on the [▶] tab, and then choose how you will select images.



- [!] may be displayed on the camera to warn you that the memory card has print settings that were configured on another camera. Changing the print settings using this camera may overwrite all previous settings.

Adding Images Individually

▶ Still Images ▶ Movies

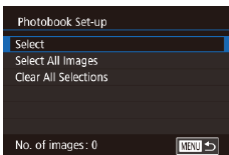

1 Choose [Select].

- Following the procedure in “Choosing a Selection Method” (197), choose [Select] and press the [OK] button.



2 Choose an image.

- Press the [◀][▶] buttons or turn the [DIAL] dial to choose an image, and then press the [OK] button.
- [✓] is displayed.
- To remove the image from the photobook, press the [OK] button again. [✓] is no longer displayed.
- Repeat this process to specify other images.
- When finished, press the [MENU] button to return to the menu screen.

Adding All Images to a Photobook

▶ Still Images ▶ Movies

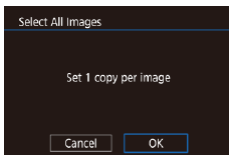

- Following the procedure in “Choosing a Selection Method” (197), choose [Select All Images] and press the [OK] button.
- Press the [◀][▶] buttons or turn the [DIAL] dial to choose [OK], and then press the [OK] button.

Removing All Images from a Photobook

▶ Still Images ▶ Movies

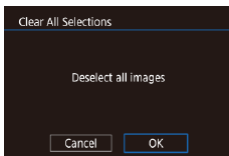

- Following the procedure in “Choosing a Selection Method” (197), choose [Clear All Selections] and press the [OK] button.
- Press the [◀][▶] buttons or turn the [DIAL] dial to choose [OK], and then press the [OK] button.

Before Use

Basic Guide

Advanced Guide

Camera Basics

Auto Mode /
Hybrid Auto Mode

Other Shooting Modes

P Mode

Tv, Av, M, and C Mode

Playback Mode

Wireless Features

Setting Menu

Accessories

Appendix

Index



Appendix

Helpful information when using the camera

Troubleshooting

If you think there is a problem with the camera, first check the following. If the issue persists, contact a Customer Support Help Desk.

Power

Nothing happens when the power button is pressed.

- Confirm that the battery pack is charged (19).
- Confirm that the battery pack is inserted facing the correct way (20).
- Confirm that the memory card/battery cover is fully closed (20).
- Dirty battery terminals reduce battery performance. Try cleaning the terminals with a cotton swab and reinserting the battery pack a few times.

The battery pack runs out of power quickly.

- Battery performance decreases at low temperatures. Try warming the battery pack a little by putting it in your pocket, for example, ensuring that the terminals do not touch any metal objects.
- Dirty battery terminals reduce battery performance. Try cleaning the terminals with a cotton swab and reinserting the battery pack a few times.
- If these measures do not help and the battery pack still runs out of power soon after charging, it has reached the end of its life. Purchase a new battery pack.

The lens is not retracted.

- Do not open the memory card/battery cover while the camera is on. Close the cover, turn the camera on, and then turn it off again (20).

The battery pack is swollen.

- Battery swelling is normal and does not pose any safety concerns. However, if battery swelling prevents the battery pack from fitting in the camera, contact a Customer Support Help Desk.

Display on a TV

Camera images look distorted or are not displayed on a TV (183).

Before Use

Basic Guide

Advanced Guide

Camera Basics

Auto Mode /
Hybrid Auto Mode

Other Shooting Modes

P Mode

Tv, Av, M, and C Mode

Playback Mode

Wireless Features

Setting Menu

Accessories

Appendix

Index



Shooting

Cannot shoot.

- In Playback mode (📖111), press the shutter button halfway (📖27).

Strange display on the screen under low light (📖29).

Strange display on the screen when shooting.

- Note that the following display problems are not recorded in still images but are recorded in movies.
 - The screen may flicker and horizontal banding may appear under fluorescent or LED lighting.

Full-screen display is not available while shooting (📖49).

⚡ flashes on the screen when the shutter button is pressed, and shooting is not possible (📖38).

📷 is displayed when the shutter button is pressed halfway (📖38).

- Set [IS Mode] to [Continuous] (📖53).
- Raise the flash and set the flash mode to ⚡ (📖96).
- Increase the ISO speed (📖80).
- Mount the camera on a tripod or take other measures to keep it still. Additionally, you should set [IS Mode] to [Off] when using a tripod or other means to secure the camera (📖53).

Shots are out of focus.

- Press the shutter button halfway to focus on subjects before pressing it all the way down to shoot (📖27).
- Make sure subjects are within focusing range (📖223).
- Set [AF-assist beam firing] to [Enable] (📖54).
- Confirm that unneeded functions such as macro are deactivated.
- Try shooting with focus lock or AF lock (📖91, 📖95).

Shots are blurry.

- Blurring may occur more often when Touch Shutter is used to shoot, depending on shooting conditions. Hold the camera still when shooting.

No AF frames are displayed and the camera does not focus when the shutter button is pressed halfway.

- To have AF frames displayed and the camera focus correctly, try composing the shot with higher-contrast subject areas centered before pressing the shutter button halfway (or pressing it halfway repeatedly).

Subjects in shots look too dark.

- Raise the flash and set the flash mode to ⚡ (📖96).
- Adjust brightness by using exposure compensation (📖78).
- Adjust brightness by using the Auto Lighting Optimizer (📖82).
- Use AE lock or spot metering (📖78, 📖79).

Subjects look too bright, highlights are washed-out.

- Lower the flash and set the flash mode to ⚡ (📖35).
- Adjust brightness by using exposure compensation (📖78).
- Use AE lock or spot metering (📖78, 📖79).
- Reduce the lighting on subjects.

Shots look too dark despite the flash firing (📖38).

- Shoot within flash range (📖223).
- Adjust brightness by using flash exposure compensation or changing the flash output level (📖97, 📖102).
- Increase the ISO speed (📖80).

Subjects in flash shots look too bright, highlights are washed-out.

- Shoot within flash range (📖223).
- Lower the flash and set the flash mode to ⚡ (📖35).
- Adjust brightness by using flash exposure compensation or changing the flash output level (📖97, 📖102).

White spots appear in flash shots.

- This is caused by light from the flash reflecting off dust or airborne particles.

Shots look grainy.

- Lower the ISO speed (📖80).
- High ISO speeds in some shooting modes may cause grainy images (📖56).

Subjects are affected by red-eye.

- Set [Red-Eye Lamp] to [On] (📖55). The red-eye reduction lamp (📖4) will light up for flash shots. For best results, have subjects look at the red-eye reduction lamp. Also try increasing the lighting in indoor scenes and shooting at closer range.
- Edit images using red-eye correction (📖131).

Recording to the memory card takes too long, or continuous shooting is slower.

- Use the camera to perform low-level formatting of the memory card (📖171).

Shooting settings or Quick Set menu settings are not available.

- Available setting items vary by shooting mode. Refer to "Functions Available in Each Shooting Mode", "Quick Set Menu", and "Shooting Tab" (📖207 – 📖212).

Before Use

Basic Guide

Advanced Guide

Camera Basics

Auto Mode /
Hybrid Auto Mode

Other Shooting Modes

P Mode

Tv, Av, M, and C Mode

Playback Mode

Wireless Features

Setting Menu

Accessories

Appendix

Index



The Babies or Children icon is not displayed.

- The Babies and Children icons will not be displayed if the birthday is not set in face information (145). If the icons still are not displayed even when you set the birthday, re-register face information (145), or make sure that the date/time is set correctly (174).

Touch AF or Touch Shutter does not work.

- Touch AF or Touch Shutter will not work if you touch the edges of the screen. Touch closer to the center of the screen.

Shooting Movies

The elapsed time shown is incorrect, or recording is interrupted.

- Use the camera to format the memory card, or switch to a card that supports high-speed recording. Note that even if the elapsed time display is incorrect, the length of movies on the memory card corresponds to the actual recording time (171).

[1] is displayed and shooting stops automatically.

- The camera's internal memory buffer filled up as the camera could not record to the memory card quickly enough. Try one of the following measures.
 - Use the camera to perform low-level formatting of the memory card (171).
 - Lower the image quality (151).
 - Switch to a memory card that supports high-speed recording.

Zooming is not possible.

- Zooming is not possible in [1] mode (167).
- Zooming is not possible when shooting movies in [1] (165) and [1] (174) modes.

Subjects look distorted.

- Subjects that pass in front of the camera quickly may look distorted. This is not a malfunction.

Playback

Playback is not possible.

- Image or movie playback may not be possible if a computer is used to rename files or alter the folder structure.

Playback stops, or audio skips.

- Switch to a memory card that you have performed low-level formatting on with the camera (171).
- There may be brief interruptions when playing movies copied to memory cards that have slow read speeds.
- When movies are played on a computer, frames may be dropped and audio may skip if computer performance is inadequate.

Sound is not played during movies.

- Adjust the volume (124) if you have activated [Mute] (175) or the sound in the movie is faint.
- No sound is played for movies shot in [1] (165), [1] (168), [1] (174), or [1] (175) mode because audio is not recorded in these modes.

Cannot access the Story Highlights home screen.

- Home screen display is not possible when connected to a printer. Disconnect the camera from the printer.
- Home screen display is not possible during Wi-Fi connections. End the Wi-Fi connection.

A desired subject icon for an album is not displayed on the Story Highlights home screen.

- In simple information display mode (113), choose an image that shows the name of the person for the album before accessing the Story Highlights home screen (136).

Memory Card

The memory card is not recognized.

- Restart the camera, with the memory card in it (126).

Before Use

Basic Guide

Advanced Guide

Camera Basics

Auto Mode /
Hybrid Auto Mode

Other Shooting Modes

P Mode

Tv, Av, M, and C Mode

Playback Mode

Wireless Features

Setting Menu

Accessories

Appendix

Index



Computer

Cannot transfer images to a computer.

- When attempting to transfer images to the computer via a cable, try reducing the transfer speed as follows.
 - Press the [▶] button to enter Playback mode. Hold the [MENU] button down as you press the [▲] and [⊞] buttons at the same time. On the next screen, press the [◀][▶] buttons to choose [B], and then press the [⊞] button.

Wi-Fi

Cannot access the Wi-Fi menu.

- The Wi-Fi menu cannot be accessed while the camera is connected to a printer, computer, or TV via a cable. Disconnect the cable.

Cannot add a device/destination.

- A total of 20 items of connection information can be added to the camera. Erase unneeded connection information from the camera first, and then add new devices/destinations (167).
- Use a computer or smartphone to register Web services (154).
- To add a smartphone, first install the dedicated application Camera Connect on your smartphone (146).
- To add a computer, first install the software CameraWindow on your computer. Also check your computer and Wi-Fi environment and settings (149, 150).
- Do not use the camera near sources of Wi-Fi signal interference such as microwave ovens or other equipment operating on the 2.4 GHz band.
- Bring the camera closer to the other device you are trying to connect to (such as the access point), and make sure there are no objects between the devices.

Cannot connect to the access point.

- Confirm that the access point channel is set to a channel supported by the camera (225). Note that instead of auto channel assignment, it is advisable to specify a supported channel manually.

Cannot send images.

- The destination device has insufficient storage space. Increase the storage space on the destination device and resend the images.
- The write-protect switch of the memory card in the destination camera is set to the locked position. Slide the write-protect switch to the unlocked position.
- RAW images cannot be sent to the camera or displayed on TV sets. RAW images selected for transferring to a smartphone are transferred as JPEG images. However, RAW images can be sent using Image Sync.
- Images cannot be sent to CANON IMAGE GATEWAY or other Web services if you move or rename image files or folders on the computer that received images sent using Image Sync via an access point (162). Before moving or renaming these image files or folders on the computer, make sure the images have already been sent to CANON IMAGE GATEWAY or other Web services.

Cannot resize images for sending.

- Images cannot be resized to be bigger than the recording pixel setting of their original size.
- Movies cannot be resized.

Images take a long time to send./The wireless connection is disrupted.

- Multiple images may take a long time to send. Try resizing the image to reduce sending time (162).
- Movies may take a long time to send.
- Do not use the camera near sources of Wi-Fi signal interference such as microwave ovens or other equipment operating on the 2.4 GHz band.
- Bring the camera closer to the other device you are trying to connect to (such as the access point), and make sure there are no objects between the devices.

No notification message is received on a computer or smartphone after adding CANON IMAGE GATEWAY to the camera.

- Make sure the email address you entered is correct, and try adding the destination again.
- Check the email settings on the computer or smartphone. If they are configured to block email from certain domains, you may not be able to receive the notification message.

Want to erase Wi-Fi connection information before disposing of the camera or giving it to someone else.

- Reset the Wi-Fi settings (169).

Before Use

Basic Guide

Advanced Guide

Camera Basics

Auto Mode /
Hybrid Auto Mode

Other Shooting Modes

P Mode

Tv, Av, M, and C Mode

Playback Mode

Wireless Features

Setting Menu

Accessories

Appendix

Index



On-Screen Messages

If an error message is displayed, respond as follows.

Shooting or Playback

No memory card

- The memory card may be inserted facing the wrong way. Reinsert the memory card facing the correct way (📖20).

Memory card locked

- The write-protect switch of the memory card is set to the locked position. Switch the write-protect switch to the unlocked position (📖20).

Cannot record!

- Shooting was attempted without a memory card in the camera. To shoot, insert a memory card facing the correct way (📖20).

Memory card error (📖171)

- If the same error message is displayed even after you have formatted a supported memory card (📖2) and have inserted it facing the correct way (📖20), contact a Customer Support Help Desk.

Insufficient space on card

- There is not enough free space on the memory card to shoot (📖35, 📖56, 📖77, 📖99) or edit images (📖128). Either erase unneeded images (📖123) or insert a memory card with enough free space (📖20).

Touch AF unavailable

- Touch AF is not available in the current shooting mode (📖207).

Touch AF canceled

- The subject selected for Touch AF can no longer be detected (📖95).

Charge the battery (📖19)

No Image.

- The memory card does not contain any images that can be displayed.

Protected! (📖121)

Unidentified Image/Incompatible JPEG/Image too large./Cannot play back MOV/Cannot play back MP4

- Unsupported or corrupt images cannot be displayed.
- It may not be possible to display images that were edited or renamed on a computer, or images shot with another camera.

Cannot magnify!/Cannot rotate/Cannot modify image/Cannot modify/Unselectable image./No identification information

- The following functions may be unavailable for images that were renamed or already edited on a computer, or images shot with another camera. Note that starred (*) functions are not available for movies.
Edit ID Info* (📖119), Magnify* (📖120), Rotate* (📖125), Favorites (📖126), Edit* (📖128), Print List* (📖194), and Photobook Set-up* (📖197).

Invalid selection range

- When specifying a range for image selection (📖122, 📖125, 📖196), you attempted to choose an initial image that was after the final image, or vice-versa.

Exceeded selection limit

- More than 998 images were selected for Print List (📖194) or Photobook Set-up (📖197). Choose 998 images or less.
- Print List (📖194) or Photobook Set-up (📖197) settings could not be saved correctly. Reduce the number of selected images and try again.
- You attempted to choose more than 500 images in Protect (📖121), Erase (📖123), Favorites (📖126), Print List (📖194), or Photobook Set-up (📖197).

Naming error!

- The folder could not be created or images could not be recorded, because the highest supported folder number (999) for storing images on the card has been reached and the highest supported image number (9999) for images in folders has been reached. On the [1] tab, change [File Numbering] to [Auto Reset] (📖170), or format the memory card (📖171).

Lens Error

- This error may occur if the lens is held while it is moving, or when the camera is used in dusty or sandy locations.
- Frequent display of this error message may indicate damage. In this case, contact a Customer Support Help Desk.

Before Use

Basic Guide

Advanced Guide

Camera Basics

Auto Mode /
Hybrid Auto Mode

Other Shooting Modes

P Mode

Tv, Av, M, and C Mode

Playback Mode

Wireless Features

Setting Menu

Accessories

Appendix

Index



A camera error was detected (*error number*)

- If this error message is displayed immediately after a shot, the image may not have been saved. Switch to Playback mode to check for the image.
- Frequent display of this error message may indicate damage. In this case, write down the error number (*Exx*) and contact a Customer Support Help Desk.

File Error

- Correct printing (📖191) may not be possible for photos from other cameras or images that have been altered using computer software, even if the camera is connected to the printer.

Print error

- Check the paper size setting (📖193). If this error message is displayed when the setting is correct, restart the printer and complete the setting on the camera again.

Ink absorber full

- Contact a Customer Support Help Desk to request assistance with ink absorber replacement.

Wi-Fi

Connection failed

- No access points were recognized. Check the access point settings (📖150).
- A device could not be found. Turn the camera off and on again, and retry the connection.
- Check the device you want to connect to and make sure it is ready for connection.

Cannot determine access point

- The WPS buttons on numerous access points were pressed simultaneously. Try reconnecting again.

No access points found

- Check to make sure that the access point is turned on.
- When connecting to an access point manually, make sure that you entered the correct SSID.

Incorrect password/Incorrect Wi-Fi security settings

- Check the access point security settings (📖150).

IP address conflict

- Reset the IP address so that it does not conflict with another.

Disconnected/Receiving failed/Sending failed

- You may be in an environment where Wi-Fi signals are obstructed.
- Avoid using the camera's Wi-Fi function around microwave ovens and other devices that operate on the 2.4 GHz band.
- Bring the camera closer to the other device you are trying to connect to (such as the access point), and make sure there are no objects between the devices.
- Check the connected device to make sure it is not experiencing errors.

Sending failed

Memory card error

- If the same error message is displayed even when you have inserted a formatted memory card facing the correct way, contact a Customer Support Help Desk.

Receiving failed

Insufficient space on card

- There is not enough free space on the memory card in the target camera to receive images. Erase images to create space on the memory card, or insert a memory card with sufficient space.

Receiving failed

Memory card locked

- The write-protect switch of the memory card in the camera to receive the images is set to the locked position. Slide the write-protect switch to the unlocked position.

Receiving failed

Naming error!

- When the highest folder number (999), and the highest image number (9999) have been reached on the receiving camera, images cannot be received.

Insufficient space on server

- Delete unnecessary images uploaded to CANON iMAGE GATEWAY to create space.
- Use Image Transfer Utility to save the images sent by the Image Sync (📖162) server to your computer.

Check network settings

- Check to make sure your computer can connect to the Internet with the current network settings.

Before Use

Basic Guide

Advanced Guide

Camera Basics

Auto Mode /
Hybrid Auto Mode

Other Shooting Modes

P Mode

Tv, Av, M, and C Mode

Playback Mode

Wireless Features

Setting Menu

Accessories

Appendix

Index



On-Screen Information

Shooting (Information Display)

The same information is shown on the viewfinder.

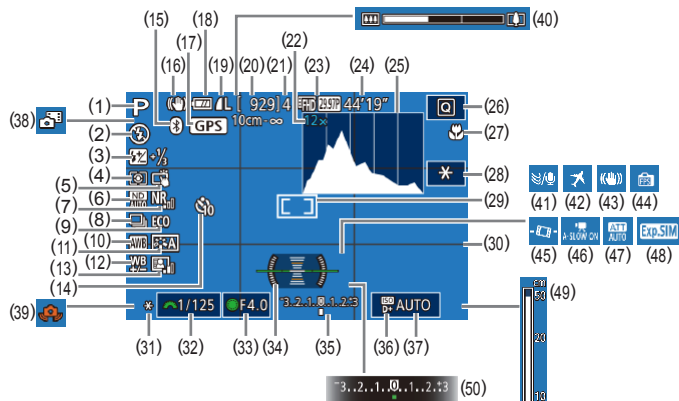

- (1) Shooting mode (📖207), Scene icon (📖39)
- (2) Flash mode (📖96)
- (3) Flash exposure compensation / Flash output level (📖97, 📖102)
- (4) Metering mode (📖79)
- (5) Touch Shutter (📖44)
- (6) ND filter (📖81)
- (7) High ISO speed noise reduction (📖80)
- (8) Drive mode (📖44), AEB shooting (📖81), Focus bracketing (📖90)
- (9) Eco mode (📖173)
- (10) White balance (📖83)
- (11) Picture Style (📖85)
- (12) White balance correction (📖84)
- (13) Auto Lighting Optimizer (📖82)
- (14) Self-timer (📖42)
- (15) Bluetooth connection status (📖142)
- (16) IS mode icon (📖41)

- (17) Connected via Bluetooth to a smartphone and acquiring GPS information (📖164)
- (18) Battery level (📖204)
- (19) Still image compression (📖50), Recording pixel setting (📖50)
- (20) Recordable shots
- (21) Maximum continuous shots
- (22) Zoom magnification (📖42), Digital tele-converter (📖91)
- (23) Movie quality (📖51)
- (24) Remaining time
- (25) Histogram (📖113)
- (26) Quick Set menu (📖30)
- (27) Focus range (📖88, 📖89), AF lock (📖95)
- (28) Movie AE lock (📖72)
- (29) AF frame (📖91), Spot AE point frame (📖79)
- (30) Grid lines (📖103)
- (31) AE lock (📖78), FE lock (📖97)
- (32) Shutter speed (📖99, 📖100)
- (33) Aperture value (📖100)
- (34) Electronic level (📖52)
- (35) Exposure level (📖100)
- (36) Highlight tone priority (📖82)
- (37) ISO speed (📖80)
- (38) Hybrid Auto mode (📖37)
- (39) Camera shake warning (📖38)
- (40) Zoom bar (📖35)
- (41) Wind filter (📖74)
- (42) Time zone (📖174)
- (43) Image stabilization (📖53)
- (44) Display mode (📖28)
- (45) 📖 Auto level (📖53)
- (46) 📖 Auto slow shutter (📖73)
- (47) Attenuator (📖74)
- (48) Exposure simulation (📖78)
- (49) MF indicator (📖89)
- (50) Exposure compensation (📖78)

Battery Level

An on-screen icon or message indicates the battery charge level.

Display	Details
	Sufficient charge
	Slightly depleted, but sufficient
	Nearly depleted—charge the battery pack soon
[Charge the battery]	Depleted—charge the battery pack immediately

Before Use

Basic Guide

Advanced Guide

Camera Basics

Auto Mode / Hybrid Auto Mode

Other Shooting Modes

P Mode

Tv, Av, M, and C Mode

Playback Mode

Wireless Features

Setting Menu

Accessories

Appendix

Index



During Playback

Info Display 1

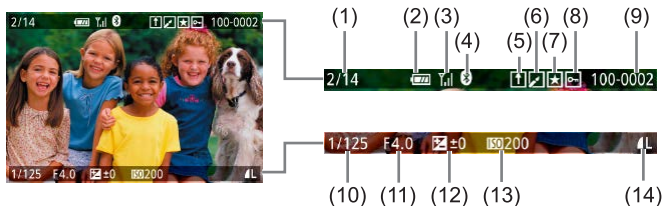

- | | |
|----------------------------------------|----------------------------------------|
| (1) Current image / Total images | (8) Protection (📖121) |
| (2) Battery level (📖204) | (9) Folder number - File number (📖170) |
| (3) Wi-Fi signal strength (📖141) | (10) Shutter speed (📖99, 📖100) |
| (4) Bluetooth connection status (📖142) | (11) Aperture value (📖100) |
| (5) Image Sync complete (📖162) | (12) Exposure compensation level (📖78) |
| (6) Edited*1 (📖128, 📖129, 📖130, 📖131) | (13) ISO speed (📖80) |
| (7) Favorites (📖126) | (14) Image quality*2 (📖50) |

*1 Displayed for images with a creative filter, resizing, cropping, or red-eye correction applied.

*2 Cropped images are labeled with [📐].

Info Display 2

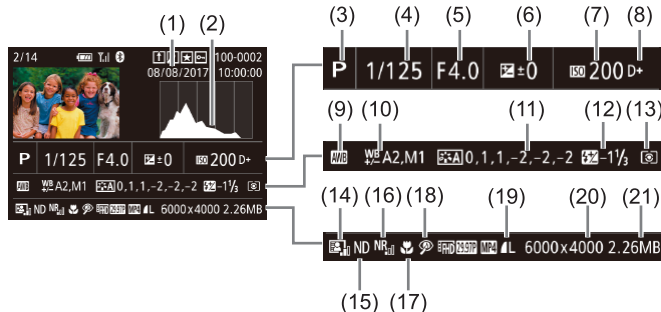

- | | |
|------------------------------------------|-----------------------------------------------------------------------------------------------------------------------------------------------------------------------------------------------------------------------------------------|
| (1) Shooting date/time (📖21) | (13) Metering mode (📖79) |
| (2) Histogram (📖113) | (14) Auto Lighting Optimizer (📖82) |
| (3) Shooting mode (📖207) | (15) ND filter (📖81), Short clip playback effect (📖74), Miniature movie playback speed (📖65), Frame rate/interval time of time-lapse movies (📖75) or star time-lapse movies (📖68), Star emphasis (📖67), Star trails shooting time (📖67) |
| (4) Shutter speed (📖99, 📖100) | (16) High ISO speed noise reduction (📖80) |
| (5) Aperture value (📖100) | (17) Focus range (📖88) |
| (6) Exposure compensation level (📖78) | (18) Red-eye correction (📖131) |
| (7) ISO speed (📖80) | (19) Image quality* (📖50) |
| (8) Highlight tone priority (📖82) | (20) Recording pixel setting |
| (9) White balance (📖83) | (21) Image size |
| (10) White balance correction (📖84) | |
| (11) Picture Style setting details (📖85) | |
| (12) Flash exposure compensation (📖97) | |

* Cropped images are labeled with [📐].

Before Use

Basic Guide

Advanced Guide

Camera Basics

Auto Mode / Hybrid Auto Mode

Other Shooting Modes

P Mode

Tv, Av, M, and C Mode

Playback Mode

Wireless Features

Setting Menu

Accessories

Appendix

Index



Info Display 3

Shows GPS information and an RGB histogram. Information on the top of the screen is the same as for Info Display 2.

Info Display 4











Shows white balance information. Information on the top of the screen is the same as for Info Display 2.

Info Display 5

Shows Picture Style information. Information on the top of the screen is the same as for Info Display 2.

Summary of Movie Control Panel

The following operations are available on the movie control panel, accessed as described in "Playback" (111).

	Touch to display the volume panel, and then touch [▲][▼] to adjust the volume. At a volume of 0, [🔊] is displayed.
	Play
	Slow Motion (To adjust the playback speed, press the [◀][▶] buttons or turn the [🌀] dial. No sound is played.)
	Skip Backward* or Previous Clip (135) (To continue skipping backward, keep holding down the [🔍] button.)
	Previous Frame (For fast-rewind, keep holding down the [🔍] button.)
	Next Frame (For fast-forward, keep holding down the [🔍] button.)
	Skip Forward* or Next Clip (135) (To continue skipping forward, keep holding down the [🔍] button.)
	Erase Clip (displayed when a digest movie (135) is selected, or an album without background music (137))
	Edit (134)
	Shown when the camera is connected to a PictBridge-compatible printer (191).

* Displays the frame approx. 4 sec. before or after the current frame.



- During movie playback, you can skip back or forward (or to the previous or next clip) by pressing the [◀][▶] buttons.

Before Use

Basic Guide

Advanced Guide

Camera Basics

Auto Mode /
Hybrid Auto Mode

Other Shooting Modes

P Mode

Tv, Av, M, and C Mode

Playback Mode

Wireless Features

Setting Menu

Accessories

Appendix

Index



Functions and Menu Tables

Functions Available in Each Shooting Mode

Function	Shooting Mode	C1	M	Av	Tv	P	AE	AUTO	SCN																						
		C2																													
Exposure Compensation (📖78)		*1	○	○	○	○	-	-	*2	○	○	○	○	○	○	○	○	○	○	○	○	○	○	○	○	○	○	○	○		
ISO Speed (📖80)	AUTO	*1	○	○	○	○	○	○	○	○	○	○	○	○	○	○	○	○	○	○	○	○	○	○	○	○	○	○			
	100 – 25600	*1	○	○	○	○	-	-	-	-	-	-	-	-	-	-	-	-	-	-	-	-	-	-	-	-	○	-			
Drive Mode (📖44)		*1	○	○	○	○	○	○	○	○	○	-	○	○	○	○	○	○	○	○	○	○	○	○	○	○	○	○			
		-	-	-	-	-	-	○	-	-	-	-	-	-	-	-	-	-	-	-	-	-	-	-	-	-	-				
		*1	○	○	○	○	-	○	-	○	-	-	-	-	-	-	-	-	-	-	-	-	-	○	-	○	○	-			
Flash (📖96)	^A	*1	-	-	-	○	○	○	-	○	○	-	-	-	-	-	○	○	○	○	○	○	○	○	○	-	○	-			
		*1	○	○	○	○	-	-	○	○	○	-	-	-	-	-	○	○	○	○	○	○	○	○	○	-	○	-			
		*1	-	○	-	○	*3	*3	-	-	-	-	-	-	-	-	*3	-	-	-	-	-	-	-	-	-	-	-			
		*1	○	○	○	○	○	○	○	○	○	○	○	○	○	○	○	○	○	○	○	○	○	○	○	○	○	○	○		
External Flash Firing (📖188)		○	○	○	○	○	○	○	○	○	○	-	-	-	-	-	○	○	○	○	○	○	○	○	○	○	-	○	-		
Flash Exposure Compensation (📖97)		*1	○	○	○	○	-	-	*4	-	-	-	-	-	-	-	-	-	-	-	-	-	-	-	-	-	-	-			
Flash Output Level (📖102)		*1	○	○	○	-	-	-	-	-	-	-	-	-	-	-	-	-	-	-	-	-	-	-	-	-	-	-			
Av/Tv Settings (📖99, 📖100)	Aperture Value	*1	○	○	-	-	-	-	-	-	-	-	-	-	-	-	-	-	-	-	-	-	-	-	-	-	-	○			
	Shutter Speed	*1	○	-	○	-	-	-	-	-	-	-	-	-	-	-	-	-	-	-	-	-	-	-	-	-	-	○			
	Bulb Setting	*1	○	-	-	-	-	-	-	-	-	-	-	-	-	-	-	-	-	-	-	-	-	-	-	-	-	-			
Program Shift (📖78)		*1	*5	*5	*5	○	-	-	-	-	-	-	-	-	-	-	-	-	-	-	-	-	-	-	-	-	*5	○			
AE Lock/FE Lock*6 (📖78, 📖97)		○	○	○	○	○	-	-	-	-	-	-	-	-	-	-	-	-	-	-	-	-	-	-	-	○	○	○			

Before Use

Basic Guide

Advanced Guide

Camera Basics

Auto Mode / Hybrid Auto Mode

Other Shooting Modes

P Mode

Tv, Av, M, and C Mode

Playback Mode

Wireless Features

Setting Menu

Accessories

Appendix

Index



Function	Shooting Mode	C1	M	Av	Tv	P	AUTO	SCN																				
		C2																										
AE Lock (during recording)/Exposure Compensation (📖72, 📖78)		○	○	○	○	○	-	-	○	○	○	○	○	○	○	○	○	○	○	○	○	○	○	○	○	○	○	○
AF Lock by touching during movie recording (📖72)		○	○	○	○	○	-	-	○	○	-	○	-	-	-	○	○	-	-	○	○	-	○	-	○	-	○	
Optical Zoom		○	○	○	○	○	○	○	○	○	○	○	○	-	-	-	○	○	○	○	○	○	○	○	○	○	○	
AF Lock (when assigned to controls other than the movie button (📖105))		○	○	○	○	○	-	-	○	○	○	○	-	-	-	○	○	○	○	○	○	○	○	○	○	○	○	
AF Lock (when assigned to the movie button (📖105))		○	○	○	○	○	-	-	○	○	○	○	-	-	-	○	○	○	○	○	○	○	○	○	○	○	○	
Focus Range (📖58, 📖88, 📖89)		*1	○	○	○	○	○	○	○	○	○	○	○	○	○	○	○	○	○	○	○	○	○	○	○	○	○	
		*1	○	○	○	○	-	-	○	○	○	○	-	-	-	○	○	○	○	○	○	○	○	○	○	○	○	
		-	-	-	-	-	-	-	-	-	-	-	-	-	-	-	-	-	-	-	-	○	-	-	-	-	-	
	MF	*1	○	○	○	○	-	-	○	○	○	○	○	○	○	○	○	○	○	○	○	○	○	○	○	○	○	○
Manual Focus Switching When Recording Movies (📖72)		○	○	○	○	○	-	-	○	○	○	○	○	○	○	○	○	○	○	○	○	○	○	○	○	○	○	
Move AF Frame (📖91)	Center	*1	○	○	○	○	-	-	○	○	○	○	○	○	○	○	○	○	○	○	○	○	○	○	○	○	○	
	Periphery	*1	○	○	○	○	○	-	-	○	○	-	○	*7	*7	*7	○	○	-	-	○	○	-	○	○	○	○	
Touch AF (📖95)		○	○	○	○	○	○	○	○	○	○	-	○	*7	*7	*7	○	○	-	-	○	○	-	○	○	○	○	
Face Select (📖94)		○	○	○	○	○	○	○	○	○	-	○	-	-	-	○	○	○	-	○	○	-	○	-	○	○	○	
Touch Shutter (📖44)		○	○	○	○	○	○	○	*8	○	○	-	○	-	-	-	○	○	*8	*8	○	○	*8	-	○	○	*8	
Change Display (📖29)		○	○	○	○	○	○	○	○	○	-	○	○	○	○	○	○	○	○	○	○	○	○	○	○	○	○	

*1 Options vary depending on the assigned shooting mode.

*2 Set in [Brightness].

*3 Not available, but switches to in some cases.

*4 Adjusted to suit the [Brightness] setting.

*5 Aperture value, shutter speed, and ISO speed may be changed automatically to maintain suitable exposure.

*6 FE lock not available in flash mode.

*7 Only when [MF] is selected.

*8 Only available for shooting. Subject designation not available.

○ Available or set automatically. - Not available.

Before Use

Basic Guide

Advanced Guide

Camera Basics

Auto Mode / Hybrid Auto Mode

Other Shooting Modes

P Mode

Tv, Av, M, and C Mode

Playback Mode

Wireless Features

Setting Menu

Accessories

Appendix

Index



Quick Set Menu

Function		Shooting Mode							SCN																											
		C1 C2	M	Av	Tv	P	AUTO																													
AF method (M91)	AF	*1	O	O	O	O	O	O	O	O	O	-	O	-	-	-	O	O	O	-	O	O	O	-	O	-	-	O	O	O	O	O	O			
	AF { }	*1	O	O	O	O	-	-	-	O	O	-	O	-	-	-	O	O	O	-	O	O	O	-	O	-	-	O	O	O	O	O	O			
	AF	*1	O	O	O	O	-	-	-	O	O	O	O	O	O	O	O	O	O	O	O	O	O	O	O	O	O	O	O	O	O	O	O	O		
AF operation (M93)	ONESHOT	*1	O	O	O	O	O	*2	O	O	O	O	O	O	O	O	O	O	O	O	O	O	O	O	O	O	O	O	O	O	O	O	O	O		
	SERVO	*1	O	O	O	O	-	-	-	-	-	O	-	-	-	-	O	-	-	O	O	O	-	O	O	-	-	-	-	-	-	-	-	-		
Image quality (M50)		See "Shooting Tab" (M212).																																		
Movie rec. size (M51)	When Set to NTSC	4K UHD 59.94P	*1	O	O	O	O	O	O	O	O	O	O	O	O	O	O	O	O	O	O	O	O	O	O	O	O	O	O	O	O	O	O	O		
		4K UHD 29.97P	*1	O	O	O	O	O	O	O	O	O	O	O	O	O	O	O	O	O	O	O	O	O	O	O	O	O	O	O	O	O	O	O	O	
		4K UHD 23.98P	*1	O	O	O	O	O	O	O	O	O	O	O	O	O	O	O	O	O	O	O	O	O	O	O	O	O	O	O	O	O	O	O	O	
		4K HD 29.97P	*1	O	O	O	O	O	O	O	O	O	O	O	O	O	O	O	O	O	O	O	O	O	O	O	O	O	*3	O	O	O	O	O	O	O
		4K VCA 29.97P	*1	O	O	O	O	O	O	O	O	O	O	O	O	O	O	O	O	O	O	O	O	O	O	O	O	O	*3	O	O	O	O	O	O	O
	When Set to PAL	4K UHD 50.00P	*1	O	O	O	O	O	O	O	O	O	O	O	O	O	O	O	O	O	O	O	O	O	O	O	O	O	O	O	O	O	O	O	O	
		4K UHD 25.00P	*1	O	O	O	O	O	O	O	O	O	O	O	O	O	O	O	O	O	O	O	O	O	O	O	O	O	O	O	O	O	O	O	O	
		4K HD 25.00P	*1	O	O	O	O	O	O	O	O	O	O	O	O	O	O	O	O	O	O	O	O	O	O	O	O	O	*3	O	O	O	O	O	O	O
		4K VCA 25.00P	*1	O	O	O	O	O	O	O	O	O	O	O	O	O	O	O	O	O	O	O	O	O	O	O	O	O	*3	O	O	O	O	O	O	O
		4K VCA 25.00P	*1	O	O	O	O	O	O	O	O	O	O	O	O	O	O	O	O	O	O	O	O	O	O	O	O	O	*3	O	O	O	O	O	O	O
Self-Timer (M42)		*1	O	O	O	O	O	O	O	O	O	O	O	O	O	O	O	O	O	O	O	O	O	O	O	O	O	O	O	O	O	O	O	O		
		*1	O	O	O	O	O	O	O	O	O	-	O	O	O	O	O	O	O	O	O	O	O	O	O	O	O	O	O	O	O	O	O	O		
Self-Timer Settings	Custom Timer	Delay* ⁴	*1	O	O	O	O	O	O	O	O	-	O	O	O	O	O	O	O	O	O	O	O	O	O	O	O	O	O	O	O	O	O	O		
		Shots* ⁵	*1	O	O	O	O	-	O	-	O	-	-	-	-	O	O	O	O	O	O	O	O	O	O	O	O	O	O	O	O	O	O	O	O	

Before Use

Basic Guide

Advanced Guide

Camera Basics

Auto Mode / Hybrid Auto Mode

Other Shooting Modes

P Mode

Tv, Av, M, and C Mode

Playback Mode

Wireless Features

Setting Menu

Accessories

Appendix

Index



Function		Shooting Mode		SCN																							
		C1 C2	M	Av	Tv	P	AUTO																				
ND Filter (81)		*1	o	o	o	o	o	o	-	-	-	-	-	o	o	o	o	o	o	o	-	-	o	o	o	o	o
		*1	o	o	o	o	-	-	o	o	o	o	o	-	-	-	-	-	o	-	-	-	o	o	-	-	-
		*1	o	o	o	o	-	-	-	-	-	-	-	-	-	-	-	-	-	-	-	-	-	-	o	o	o
White balance (83)		*1	o	o	o	o	o	o	o	o	o	o	o	o	o	o	o	o	o	o	o	o	o	o	o	o	o
		*1	o	o	o	o	-	-	-	-	-	-	-	-	-	-	-	-	-	-	-	-	-	o	o	o	o
		*1	o	o	o	o	-	-	-	-	-	-	-	-	-	-	-	-	-	-	-	-	-	-	-	-	-
		*1	o	o	o	o	-	-	-	-	-	-	-	-	-	-	-	-	-	-	-	-	o	-	o	o	o
WB correction (84)		*1	o	o	o	o	-	-	-	-	-	-	-	-	-	-	-	-	-	-	-	-	-	o	o	o	o
WB correction (Underwater) (58)		-	-	-	-	-	-	-	-	-	-	-	-	-	-	-	-	-	-	-	-	-	o	-	-	-	-
Color Adjustment (70)		-	-	-	-	-	-	-	-	-	-	-	-	o	o	o	-	-	-	-	-	-	-	-	-	-	-
Set color temp. (84)		*1	o	o	o	o	-	-	-	-	-	-	-	-	-	-	-	-	-	-	-	-	-	-	o	o	o
Picture Style (85)		*1	o	o	o	o	o	o	-	o	-	o	o	-	-	-	-	-	-	-	-	-	-	-	o	o	o
		*1	o	o	o	o	-	-	o	-	o	-	-	o	o	o	o	o	o	o	o	o	o	o	o	o	o
		*1	o	o	o	o	-	-	-	-	-	-	-	-	-	-	-	-	-	-	-	-	-	-	o	o	o
Metering mode (79)		*1	o	o	o	o	o	o	o	o	o	o	o	o	o	o	o	o	o	o	o	o	o	o	o	o	o
		*1	o	o	o	o	-	-	-	-	-	-	-	-	-	-	-	-	-	-	-	-	-	-	-	-	-
Auto Lighting Optimizer (82)		*1	o	o	o	o	-	-	o	-	o	o	-	o	o	o	-	o	o	o	o	o	o	o	o	o	o
		*1	o	o	o	o	-	-	-	-	-	-	-	-	-	-	-	-	-	-	-	-	-	-	o	-	o
		*1	o	o	o	o	o	o	-	o	-	o	-	-	o	-	-	-	-	-	-	-	-	o	-	o	-

Before Use

Basic Guide

Advanced Guide

Camera Basics

Auto Mode / Hybrid Auto Mode

Other Shooting Modes

P Mode

Tv, Av, M, and C Mode

Playback Mode

Wireless Features

Setting Menu

Accessories

Appendix

Index



Function	Shooting Mode	C1 C2	M	Av	Tv	P	AUTO	SCN																							
								[Icon]	[Icon]	[Icon]	[Icon]	[Icon]	[Icon]	[Icon]	[Icon]	[Icon]	[Icon]	[Icon]	[Icon]	[Icon]	[Icon]	[Icon]	[Icon]	[Icon]	[Icon]	[Icon]	[Icon]	[Icon]	[Icon]	[Icon]	
Still Image Aspect Ratio (49)	16:9	*1	o	o	o	o	-	o	-	o	o	-	o	o	o	o	-	o	o	o	o	o	o	o	o	o	o	*6	o	*6	o
	3:2	*1	o	o	o	o	o	o	o	o	o	o	o	o	o	o	-	o	o	o	o	o	o	o	o	o	o	-	-	-	-
	4:3	*1	o	o	o	o	-	o	-	o	o	-	o	o	o	-	-	o	-	-	-	-	o	-	o	o	*6	-	*6	-	
	1:1	*1	o	o	o	o	-	o	o	o	o	-	o	o	o	-	-	o	-	-	-	-	o	-	o	o	-	-	-	-	

*1 Options vary depending on the assigned shooting mode.

*2 [SERVO] when subject movement is detected.

*3 Synchronizes with the aspect ratio setting and is automatically set (49).

*4 Cannot be set to 0 seconds in modes without selection of the number of shots.

*5 One shot (cannot be modified) in modes without selection of the number of shots.

*6 Set automatically to suit the aspect ratio of the movie recording size.

o Available or set automatically. - Not available.

Before Use

Basic Guide

Advanced Guide

Camera Basics

Auto Mode /
Hybrid Auto Mode

Other Shooting Modes

P Mode

Tv, Av, M, and C Mode

Playback Mode

Wireless Features

Setting Menu

Accessories

Appendix

Index



Shooting Tab

Function			Shooting Mode							SCN																												
			C1 C2	M	Av	Tv	P	AUTO																														
	Rec. Mode (56, 59, 72)		-	-	-	-	-	-	-	o	o	o	o	o	o	o	o	o	o	o	o	o	o	o	o	o	o	o	o	o	o	o	o	o	o	o		
	Image quality (50)	JPEG	-	*1	o	o	o	o	-	o	-	o	-	-	-	-	-	-	-	-	-	-	-	-	-	o	o	o	o	o	o	o	o	o	o			
				*1	o	o	o	o	o	o	o	o	o	o	o	o	o	o	o	o	o	o	o	o	o	o	o	o	o	o	o	o	o	o	o	o		
		L/AM/AS1 S1/S2	*1	o	o	o	o	-	o	o	o	o	-	o	-	-	-	o	o	o	o	o	o	o	o	o	o	o	o	o	o	o	o	o	o	o		
	RAW	-	*1	o	o	o	o	o	o	o	o	o	o	o	o	o	o	o	o	o	o	o	o	o	o	o	o	o	o	o	o	o	o	o	o	o		
			*1	o	o	o	o	-	o	-	o	-	-	-	-	-	-	-	-	-	-	-	-	-	-	-	o	o	o	o	o	o	o	o	o	o		
	Still Image Aspect Ratio			See "Quick Set Menu" (209).																																		
	Shooting info/ toggle settings		Custom display 1/ Custom display 2/ No info display	o	o	o	o	o	o	o	o	o	o	o	o	o	o	o	o	o	o	o	o	o	o	o	o	o	o	o	o	o	o	o	o	o	o	
	VF info/ toggle settings		No info display/ Custom display 1/ Custom display 2	o	o	o	o	o	o	o	-	o	o	o	o	o	o	o	o	o	o	o	o	o	o	o	o	o	o	o	o	o	o	o	o	o	o	
	VF vertical display		On	*1	o	o	o	o	o	o	-	o	o	o	o	o	o	o	o	o	o	o	o	o	o	o	o	o	o	o	o	o	o	o	o	-	-	-
			Off	*1	o	o	o	o	o	o	o	-	o	o	o	o	o	o	o	o	o	o	o	o	o	o	o	o	o	o	o	o	o	o	o	o	o	o
	Grid display		3x3 /6x4 3x3+diag	*1	o	o	o	o	o	o	o	o	o	o	o	o	o	o	o	o	o	o	o	o	o	o	o	o	o	o	o	o	o	o	o	o	o	o
	Histogram		Brightness/ RGB	Brightness/ RGB	*1	o	o	o	o	o	o	o	o	o	o	o	o	o	o	o	o	o	o	o	o	o	o	o	o	o	o	o	o	o	o	o	o	o
Display size			Large/ Small	*1	o	o	o	o	o	o	o	o	o	o	o	o	o	o	o	o	o	o	o	o	o	o	o	o	o	o	o	o	o	o	o	o	o	o
Expo. simulation (78)		Enable	*1	o	o	o	o	o	o	o	o	o	o	o	o	o	o	o	o	o	o	o	o	o	o	o	o	o	o	o	o	o	o	o	o	o	o	
		Disable	*1	o	o	o	o	-	-	-	-	-	-	-	-	-	-	-	-	-	-	-	-	-	-	-	-	-	-	-	-	-	-	-	-	-	-	

Before Use

Basic Guide

Advanced Guide

Camera Basics

Auto Mode /
Hybrid Auto Mode

Other Shooting Modes

P Mode

Tv, Av, M, and C Mode

Playback Mode

Wireless Features

Setting Menu

Accessories

Appendix

Index



Shooting Mode				C1	M	Av	Tv	P	AUTO	SCN																															
Function				C2																																					
Camera 2	Face ID Settings (145)	Face ID	On/Off	*1	O	O	O	O	O	O	O	O	O	O	O	O	O	O	O	O	O	O	O	O	O	O	O	O	O	O	O	O	O	O	O	O	O	O			
		Shutter/AE lock	AF/AE lock	*1	O	O	O	O	O	O	O	O	O	O	O	O	O	O	O	O	O	O	O	O	O	O	O	O	O	O	O	O	O	O	O	O	O	O	O		
			AE lock/AF	*1	O	O	O	O	-	-	-	-	-	-	-	-	-	-	-	-	-	-	-	-	-	-	-	-	-	-	-	-	-	-	-	-	-	-	-	-	
	AF/AF lock, no AE lock		*1	O	O	O	O	-	-	-	-	-	-	-	-	-	-	-	-	-	-	-	-	-	-	-	-	-	-	-	-	-	-	-	-	-	-	-	-		
	Dials	AE/AF, no AE lock	*1	O	O	O	O	-	-	-	-	-	-	-	-	-	-	-	-	-	-	-	-	-	-	-	-	-	-	-	-	-	-	-	-	-	-	-	-		
		Dials		*1	-	-	-	-	O	O	O	O	O	O	O	O	O	O	O	O	O	O	O	O	O	O	O	O	O	O	O	O	O	O	O	O	O	O	O		
				*1	O	O	O	O	-	-	-	-	-	-	-	-	-	-	-	-	-	-	-	-	-	-	-	-	-	-	-	-	-	-	-	-	-	O	-		
	button		*1	O	O	O	O	O	O	O	O	O	O	O	O	O	O	O	O	O	O	O	O	O	O	O	O	O	O	O	O	O	O	O	O	O	O	O	O	O	
	button		*1	O	O	O	O	O	O	O	O	O	O	O	O	O	O	O	O	O	O	O	O	O	O	O	O	O	O	O	O	O	O	O	O	O	O	O	O	O	O
	Quick setting menu layout (107)				O	O	O	O	O	O	O	O	O	O	O	O	O	O	O	O	O	O	O	O	O	O	O	O	O	O	O	O	O	O	O	O	O	O	O	O	O

Before Use

Basic Guide

Advanced Guide

Camera Basics

Auto Mode / Hybrid Auto Mode

Other Shooting Modes

P Mode

Tv, Av, M, and C Mode

Playback Mode

Wireless Features

Setting Menu

Accessories

Appendix

Index



Function		Shooting Mode	C1	SCN																												
			C2	M	Av	Tv	P	AUTO																								
	Digital Zoom (42)	Standard	*1	○	○	○	○	○	○	-	○	-	-	○	-	-	-	-	-	-	-	-	-	-	○	○	○	-	○	○		
		Off	*1	○	○	○	○	○	○	○	○	○	○	○	○	○	○	○	○	○	○	○	○	○	○	○	○	○	○	○	○	
		1.6x/2.0x	*1	○	○	○	○	-	-	-	-	-	-	-	-	-	-	-	-	-	-	-	-	-	-	-	-	-	-	-	-	
	AF operation		See "Quick Set Menu" (209).																													
	AF method		See "Quick Set Menu" (209).																													
	AF Frame Size ^{*2} (91)	Normal	*1	○	○	○	○	-	-	-	○	○	○	○	-	-	-	-	○	○	○	○	○	○	-	○	○	-	○	○	○	
		Small	*1	○	○	○	○	-	-	-	○	○	○	○	-	-	-	-	○	○	-	○	○	○	-	○	○	-	-	-	-	
	Continuous AF (93)	Enable	*1	○	○	○	○	○	○	○	○	○	○	○	-	-	-	○	○	○	○	○	○	○	○	○	○	○	○	○	○	
		Disable	*1	○	○	○	○	-	-	○	○	○	○	○	○	○	○	○	○	○	○	○	○	○	○	○	○	○	○	-	-	-
	AF+MF (94)	On/Off	*1	○	○	○	○	-	-	-	○	○	○	○	○	○	○	○	○	○	○	○	○	○	○	○	○	○	○	-	○	○
AF-assist beam firing (54)		Enable	*1	○	○	○	○	○	○	○	○	○	○	○	-	-	-	○	○	○	○	○	○	○	○	○	○	○	-	-	○	○
	Disable	*1	○	○	○	○	○	○	○	○	○	○	○	○	○	○	○	○	○	○	○	○	○	○	○	○	○	○	○	○	○	○

Before Use

Basic Guide

Advanced Guide

Camera Basics

Auto Mode / Hybrid Auto Mode

Other Shooting Modes

P Mode

Tv, Av, M, and C Mode

Playback Mode

Wireless Features

Setting Menu

Accessories

Appendix

Index



Function		Shooting Mode		C1	M	Av	Tv	P	AUTO	SCN																							
		C2																															
4	MF-Point Zoom (p.89)	Off	*1	o	o	o	o	o	o	o	o	o	o	o	o	o	o	o	o	o	o	o	o	o	o	o	o	o					
		5x/10x	*1	o	o	o	o	-	-	-	o	-	-	-	o	o	o	-	o	-	-	-	-	-	-	o	-	-	-				
	Safety MF (p.89)	On	*1	o	o	o	o	-	-	-	o	o	-	-	-	-	o	o	o	o	-	-	o	o	o	o	-	o	o	o			
		Off	*1	o	o	o	o	o	o	o	o	o	o	o	o	o	o	o	o	o	o	o	o	o	o	o	o	o	o	o			
	MF Peaking Settings (p.90)	Peaking	On	*1	o	o	o	o	-	-	-	o	o	o	o	o	o	o	o	o	o	o	o	o	o	o	o	o	-	o	o	o	o
			Off	*1	o	o	o	o	o	o	o	o	o	o	o	o	o	o	o	o	o	o	o	o	o	o	o	o	o	o	o	o	o
		Level	Low/High	*1	o	o	o	o	-	-	-	o	o	o	o	o	o	o	o	o	o	o	o	o	o	o	o	o	-	o	o	o	o
	Color	Red/Yellow/Blue	*1	o	o	o	o	-	-	-	o	o	o	o	o	o	o	o	o	o	o	o	o	o	o	o	o	o	-	o	o	o	o
		IS Mode	Off	*1	o	o	o	o	o	o	o	o	o	-	-	o	o	o	o	o	o	o	o	o	o	o	o	o	o	o	o	o	o
	IS Settings (p.98)	Dynamic IS	Continuous	*1	o	o	o	o	o	o	o	o	o	-	o	-	-	-	o	o	o	o	o	o	o	o	o	o	o	o	o	o	-
			Shoot Only	*1	o	o	o	o	-	-	o	o	o	o	-	-	-	-	o	o	o	o	o	o	o	o	o	o	o	-	-	-	-
			Low	*1	o	o	o	o	o	o	o	o	o	o	o	o	o	o	-	o	o	o	o	o	o	o	o	o	o	o	o	o	o
		Standard	*1	o	o	o	o	o	o	o	o	o	o	o	-	-	-	o	o	o	o	o	o	o	o	o	-	o	o	o	-	o	-
	High	-	-	-	-	-	-	-	-	-	-	-	-	-	-	-	-	-	-	-	-	-	-	-	-	-	-	o	-	o	-		
	Auto level (p.53)	Enable	*1	o	o	o	o	o	o	o	o	o	o	o	-	-	-	o	o	o	o	o	o	o	o	o	o	-	o	o	o	-	o
Disable		*1	o	o	o	o	o	o	o	o	o	o	o	o	o	o	o	o	o	o	o	o	o	o	o	o	o	o	o	o	o	o	

Before Use

Basic Guide

Advanced Guide

Camera Basics

Auto Mode / Hybrid Auto Mode

Other Shooting Modes

P Mode

Tv, Av, M, and C Mode

Playback Mode

Wireless Features

Setting Menu

Accessories

Appendix

Index



Function		Shooting Mode		C1	M	Av	Tv	P	AUTO	SCN																								
		C2																																
5	Bracketing (89)	OFF	*1	O	O	O	O	O	O	O	O	O	O	O	O	O	O	O	O	O	O	O	O	O	O	O	O							
		ON	*1	O	O	O	O	-	-	-	-	-	-	-	-	-	-	-	-	-	-	-	-	-	-	-	-							
	ISO Speed (80)	ISO Speed		See "Functions Available in Each Shooting Mode" (207).																														
		ISO Auto Settings	Max ISO Speed	*1	O	O	O	O	-	-	-	-	-	-	-	-	-	-	-	-	-	-	-	-	-	-	-	O	-					
			Rate of Change	Standard	*1	O	O	O	O	O	O	O	O	O	O	O	O	O	O	O	O	O	O	O	O	O	O	O	O	O	O			
	Fast/Slow	*1		-	O	-	O	-	-	-	-	-	-	-	-	-	-	-	-	-	-	-	-	-	-	-	-	-	-					
	Highlight tone priority (82)	Disable		*1	O	O	O	O	O	O	O	O	O	O	O	O	O	O	O	O	O	O	O	O	O	O	O	O	O					
		Enable		*1	O	O	O	O	-	-	-	-	-	-	-	-	-	-	-	-	-	-	-	-	-	-	O	-	O	-				
	Auto Lighting Optimizer (82)		See "Quick Set Menu" (209).																															
	Metering mode (79)		See "Quick Set Menu" (209).																															
	ND Filter (81)		See "Quick Set Menu" (209).																															
	Flash Control (55, 97, 98, 102)	Flash Mode	Auto	*1	O	O	O	O	O	O	O	O	O	-	-	-	-	-	O	O	O	O	O	O	O	O	O	-	O	-	-	-	-	
			Manual	*1	O	O	O	-	-	-	-	-	-	-	-	-	-	-	-	-	-	-	-	-	-	-	-	-	-	-	-	-	-	
		Flash Exp. Comp		See "Functions Available in Each Shooting Mode" (207).																														
		Flash Output		See "Functions Available in Each Shooting Mode" (207).																														
		Shutter Sync.	1st-curtain	*1	O	O	O	O	O	O	O	O	O	-	-	-	-	-	O	O	O	O	O	O	O	O	O	O	-	O	-	-	-	-
			2nd-curtain	*1	O	O	O	O	-	-	-	-	-	-	-	-	-	-	-	-	-	-	-	-	-	-	-	-	-	-	-	-	-	
		Red-Eye Lamp	On	*1	O	O	O	O	O	O	O	O	O	-	-	-	-	-	O	O	O	O	O	O	O	O	O	O	-	O	-	-	-	-
			Off	*1	O	O	O	O	O	O	O	O	O	-	-	-	-	-	O	O	O	O	O	O	O	O	O	O	-	O	-	-	-	-
		Safety FE	On	*1	O	O	O	O	O	O	O	O	O	-	-	-	-	-	O	O	O	O	O	O	O	O	O	O	-	O	-	-	-	-
Off			*1	O	O	O	O	-	-	-	-	-	-	-	-	-	-	-	-	-	-	-	-	-	-	-	-	-	-	-	-	-		
Color Adjustment		See "Quick Set Menu" (209).																																

Before Use

Basic Guide

Advanced Guide

Camera Basics

Auto Mode / Hybrid Auto Mode

Other Shooting Modes

P Mode

Tv, Av, M, and C Mode

Playback Mode

Wireless Features

Setting Menu

Accessories

Appendix

Index



Function	Shooting Mode	C1	C2	M	Av	Tv	P	AUTO	SCN																									
White balance (83)		See "Quick Set Menu" (209).																																
Custom WB (83)		O	O	O	O	O	-	-	-	-	-	-	-	-	-	-	-	-	-	-	-	-	-	-	-	-	-	-	O	-	O	O	O	O
WB correction (84)		See "Quick Set Menu" (209).																																
Picture Style (85)		See "Quick Set Menu" (209).																																
High ISO speed NR (80)	Standard	*1	O	O	O	O	O	O	O	O	O	O	O	O	O	O	O	O	O	O	O	O	O	O	O	O	O	O	O	O	O	O	O	O
	Low/High	*1	O	O	O	O	-	-	-	-	-	-	-	-	-	-	-	-	-	-	-	-	-	-	-	-	-	-	-	-	-	-	-	-
Spot AE Point (79)	Center/AF Point	*1	O	O	O	O	-	-	-	-	-	-	-	-	-	-	-	-	-	-	-	-	-	-	-	-	-	-	-	-	-	-	-	
Safety shift (100)	On	*1	-	O	O	-	-	-	-	-	-	-	-	-	-	-	-	-	-	-	-	-	-	-	-	-	-	-	-	-	-	-	-	
	Off	*1	O	O	O	O	O	O	O	O	O	O	O	O	O	O	O	O	O	O	O	O	O	O	O	O	O	O	O	O	O	O	O	

Before Use

Basic Guide

Advanced Guide

Camera Basics

Auto Mode / Hybrid Auto Mode

Other Shooting Modes

P Mode

Tv, Av, M, and C Mode

Playback Mode

Wireless Features

Setting Menu

Accessories

Appendix

Index



Function	Shooting Mode	SCN																							
		C1 C2	M	Av	Tv	P																			
Self-Timer		See "Quick Set Menu" (209).																							
Digest Type (37)	Include Stills/ No Stills	-	-	-	-	-	○	-	-	-	-	-	-	-	-	-	-	-	-	-	-	-	-	-	-
Star Emphasis (67)	Sharp/Soft	-	-	-	-	-	-	-	-	-	-	-	○	-	-	-	-	-	-	-	-	-	-	-	-
	Off	○	○	○	○	○	○	○	○	○	○	○	○	○	○	○	○	○	○	○	○	○	○	○	○
Star Time-Lapse Movie Setting	Save Stills	-	-	-	-	-	-	-	-	-	-	-	○	-	-	-	-	-	-	-	-	-	-	-	
	Effect*3	-	-	-	-	-	-	-	-	-	-	-	○	-	-	-	-	-	-	-	-	-	-	-	
*7	Shot Interval	-	-	-	-	-	-	-	-	-	-	-	○	-	-	-	-	-	-	-	-	-	-	-	
	Frame Rate	-	-	-	-	-	-	-	-	-	-	-	-	○	-	-	-	-	-	-	-	-	-	-	
	Shooting Time	-	-	-	-	-	-	-	-	-	-	-	-	○	-	-	-	-	-	-	-	-	-	-	
	Auto exposure	-	-	-	-	-	-	-	-	-	-	-	-	○	-	-	-	-	-	-	-	-	-	-	
	Shooting scene	Scene 1/Scene 2/ Scene 3	-	-	-	-	-	-	-	-	-	-	-	-	-	-	-	-	-	-	-	-	-	-	○
Time-lapse movie settings	Interval/ Shots	-	-	-	-	-	-	-	-	-	-	-	-	-	-	-	-	-	-	-	-	-	-	○	
	Exposure	-	-	-	-	-	-	-	-	-	-	-	-	-	-	-	-	-	-	-	-	-	-	○	
*7	Review image	-	-	-	-	-	-	-	-	-	-	-	-	-	-	-	-	-	-	-	-	-	-	○	

- Before Use
- Basic Guide
- Advanced Guide
- Camera Basics
- Auto Mode / Hybrid Auto Mode
- Other Shooting Modes
- P Mode
- Tv, Av, M, and C Mode
- Playback Mode
- Wireless Features
- Setting Menu
- Accessories
- Appendix
- Index



Function		Shooting Mode		SCN																								
		C1 C2	M Av Tv P	AUTO																								
	Movie rec. size (📖51)	See "Quick Set Menu" (📖209).																										
	Wind Filter (📖74)	Auto	*1	○	○	○	○	○	○	○	○	○	○	○	○	○	○	○	○	○	○	○	○	○	○	○	○	○
		Off	*1	○	○	○	○	–	–	–	–	–	–	–	–	○	–	–	–	–	–	○	–	–	○	○	○	○
	Attenuator (📖74)	Auto	*1	○	○	○	○	○	○	○	○	○	○	○	○	○	○	○	○	○	○	○	○	○	○	○	○	○
		Off/On	*1	○	○	○	○	–	–	–	–	–	–	–	–	–	–	–	–	–	–	–	–	○	–	○	–	
	Auto slow shutter (📖73)	Enable	○	○	○	○	○	○	○	○	○	○	○	○	○	○	○	○	○	○	○	○	○	○	○	○	○	○
Disable		○	○	○	○	○	○	○	○	○	○	○	○	○	○	○	○	○	○	○	○	○	○	○	○	○	○	

*1 Options vary depending on the assigned shooting mode.

*2 Only available when the AF method is [1-point AF].

*3 Available when still saving is set to [Disable].

*4 Available when the effect is set to [Off].

*5 Items from the 8 tab are shown on the 5 tab in mode. Items from the 7 tab are shown on the 5 tab in these modes: , [HDR], and . Items from the 6 tab are shown on the 5 tab in mode.

*6 Items from the 8 tab are shown on the 6 tab in these modes: , [HDR], and . Items from the 7 tab are shown on the 6 tab in these modes: , [AUTO], , , , , , , , , , , , , , , , and .

*7 Items from the 8 tab are shown on the 7 tab in these modes: , [AUTO], , , , , , , , , , and .

- Names of people in shots taken using Face ID (📖45) may not be displayed in some modes or with some settings, but they will be recorded in the still images.

○ Available or set automatically. – Not available.

- Before Use
- Basic Guide
- Advanced Guide
 - Camera Basics
 - Auto Mode / Hybrid Auto Mode
 - Other Shooting Modes
 - P Mode
 - Tv, Av, M, and C Mode
 - Playback Mode
 - Wireless Features
 - Setting Menu
 - Accessories
 - Appendix
- Index



Set Up Tab

Tab	Item	Reference Page
🔑1	Create Folder	📖170
	File Numbering	📖170
	Format	📖171
	Video system	📖172
	Display settings	📖28
	Electronic level	📖52
	Start-up Image	📖175
🔑2	Eco Mode	📖173
	Power Saving	📖27
	Disp. Brightness	📖173
	Night Display	📖172
	Time Zone	📖174
	Date/Time	📖174
	Lens Retraction	📖174
🔑3	Language 🗺️	📖175
	Mute	📖175
	Volume	📖175
	Sound Options	📖175
	Hints & Tips	📖176
	Mode icon size/info*1	📖176
🔑4	Touch Operation	📖176
	Units	📖176
	Wi-Fi connect'n	📖141
	Wireless settings	📖141
	GPS settings	📖164

Tab	Item	Reference Page
🔑5	Certification Logo Display	📖176
	Custom shooting mode (C1, C2)*2	📖108
	Copyright Info	📖177
	Reset camera*3	📖177

*1 Not available in these modes: [C1], [C2], [M], [Av], [Tv], [P], [A], and [AUTO].

*2 Not available in these modes: [A], [AUTO], [SCN], and [P].

*3 Only [Other settings] is available in [C1] and [C2] modes.

My Menu Tab

Tab	Item	Reference Page	
★1	Add My Menu tab	📖109	
	Delete all My Menu tabs	📖110	
	Delete all items	📖110	
	Menu display	📖110	

Before Use

Basic Guide

Advanced Guide

Camera Basics

Auto Mode /
Hybrid Auto Mode

Other Shooting Modes

P Mode

Tv, Av, M, and C Mode

Playback Mode

Wireless Features

Setting Menu

Accessories

Appendix

Index



Playback Tab

Tab	Item	Reference Page
▶1	Protect	📖121
	Rotate	📖125
	Erase	📖123
	Favorites	📖126
	Slideshow	📖121
▶2	📖 Story Highlights	📖136
	List/Play Digest Movies	📖114
	Short Clip Mix	📖139
	Image Search	📖116
	Creative filters	📖130
▶3	Resize	📖128
	Cropping	📖129
	Red-Eye Correction	📖131
	Face ID Info	📖115
	RAW img processing	📖132
▶4	Print settings	📖195
	Photobook Set-up	📖197
▶5	Transition Effect	📖111
	Index Effect	📖115
	Scroll Display	📖111
	Group Images	📖118
	Auto Rotate	📖126
	Resume	📖111
	Image jump w/ 	📖117
▶6	Set Touch Actions	📖127
	Playback information display	📖113

Handling Precautions

- The camera is a high-precision electronic device. Avoid dropping it or subjecting it to strong impact.
- Never bring the camera near magnets, motors, or other devices that generate strong electromagnetic fields. Strong electromagnetic fields may cause malfunction or erase image data.
- The camera is not waterproof and cannot be used underwater.
- To maximize the camera's dust- and drip- resistance, keep the terminal cover, memory card/battery cover, and all other covers firmly closed.
- This camera is designed to be dust- and drip- resistant, in order to help prevent sand, dust, dirt, or water that falls on it unexpectedly from getting inside, but it is impossible to prevent dirt, dust, water, or salt from getting inside at all. As far as possible, do not allow dirt, dust, water, and salt to get on the camera.
- If water gets on the camera, wipe it off with a dry and clean cloth. If dirt, dust, or salt gets on the camera, wipe it off with a clean, well-wrung wet cloth.
- Using the camera in a location with large amounts of dirt or dust may cause a malfunction.
- Cleaning the camera after use is recommended. Allowing dirt, dust, water, or salt to remain on the camera may cause a malfunction.
- If you accidentally drop the camera into water or are concerned that moisture (water), dirt, dust, or salt may have gotten inside it, promptly consult the nearest Customer Support Help Desk.
- Never use cleaners containing organic solvents to clean the camera or screen.
- Use a blower brush to remove dust from the lens. If cleaning is difficult, contact a Customer Support Help Desk.
- Store unused battery packs in a plastic bag or other container. To maintain battery performance if you will not use the battery pack for some time, about once a year charge it and then use the camera until it runs out of power before storing the battery pack.

Before Use

Basic Guide

Advanced Guide

Camera Basics

Auto Mode /
Hybrid Auto Mode

Other Shooting Modes

P Mode

Tv, Av, M, and C Mode

Playback Mode

Wireless Features

Setting Menu

Accessories

Appendix

Index



Specifications





Image Sensor

Image sizeAPS-C
Camera Effective Pixels
(Pixels may decrease due to image
processing)Approx. 24.2 megapixels
Total pixelsApprox. 25.8 megapixels

Lens

Focal Length
(35mm film equivalent) 15.0 - 45.0 mm (24 - 72 mm)
Zoom Magnification3x

Shooting Range (measured from the tip of the lens)

Shooting Mode	Focus Range	Maximum Wide Angle ()	Maximum Telephoto ()
AUTO	—	10 cm – infinity (3.9 in. – infinity)	30 cm – infinity (11.8 in. – infinity)
Other modes		10 cm – infinity (3.9 in. – infinity)	30 cm – infinity (11.8 in. – infinity)
	 	10 – 50 cm (3.9 in. – 1.6 ft.)	—

Step Zoom24 mm, 28 mm, 35 mm, 50 mm,
72 mm

Shutter

Shutter Speed

Auto Mode (automatic settings)
Max. Tv 1 sec.
Min. Tv 1/2000 sec.
Range in all shooting modes
Max. Tv 30 sec.
Min. Tv 1/2000 sec.

Aperture

F number

Wide angle2.8 - 16.0
Telephoto5.6 - 16.0

Flash

Built-in Flash

Flash range (Max. wide angle)
closest pointApprox. 50.0 cm (approx. 1.6 ft.)
farthest pointApprox. 9.0 m (approx. 29.5 ft.)
Flash range (Telephoto end)
closest pointApprox. 50.0 cm (approx. 1.6 ft.)
farthest pointApprox. 4.5 m (approx. 14.8 ft.)

Viewfinder/Monitor

Electronic color viewfinder

Screen Size0.39 type
PixelsApprox. 2.36 million dots

Monitor

TypeTFT color liquid crystal
Screen Size3.0 type
Effective PixelsApprox. 1.04 million dots

Before Use

Basic Guide

Advanced Guide

Camera Basics

Auto Mode /
Hybrid Auto Mode

Other Shooting Modes

P Mode

Tv, Av, M, and C Mode

Playback Mode

Wireless Features

Setting Menu

Accessories

Appendix

Index



Shooting

Digital zoom

Magnification.....	Approx. 4x
Maximum with optical zoom.....	Approx. 12x
Focal Length (Telephoto end, 35mm film equivalent)	Approx. 288 mm equivalent

Continuous Shooting

Shooting speed*

One-Shot AF

High-speed Continuous shooting speed	Max approx. 9.0 shots/sec.
-----------------------------------------------	----------------------------

Servo AF

High-speed Continuous shooting speed	Max approx. 7.0 shots/sec.
-----------------------------------------------	----------------------------

* Continuous shooting speed may become slower due to the following factors:
Tv value/Av value/Subject conditions/Brightness/Shooting with flash/Zoom
positions/Battery level

Recording

File Format.....	DCF-compliant DPOF compatible (Version1.1)
------------------	-----------------------------------------------

Data Type

Still Images

Recording Format.....	Exif2.3 (DCF2.0)
Image (RAW images taken while shooting are A/D converted into 12-bit format.)	JPEG/RAW (CR2 a Canon 14-bit RAW format)

Movies

Recording Format.....	MP4
Video.....	MPEG-4 AVC/H.264
Audio	MPEG-4 AAC-LC (stereo)

Before Use

Basic Guide

Advanced Guide

Camera Basics

Auto Mode /
Hybrid Auto Mode

Other Shooting Modes

P Mode

Tv, Av, M, and C Mode

Playback Mode

Wireless Features

Setting Menu

Accessories

Appendix

Index



Power

Battery PackNB-13L

Number of Still Image Shots (CIPA compliant: room temperature 23°C / 73°F)	Screen (Monitor) On	Approx. 200 shots
	Viewfinder On	Approx. 200 shots
Number of Still Image Shots (Eco Mode On)	Screen (Monitor) On	Approx. 250 shots
Movie Recording Time (CIPA compliant: room temperature 23°C / 73°F)	Screen (Monitor) On	Approx. 45 min.
	Viewfinder On	Approx. 45 min.
Movie Recording Time (Continuous Shooting)	Screen (Monitor) On	Approx. 80 min.
	Viewfinder On	Approx. 80 min.
Playback Time*		Approx. 4 hr.

* Time when playing back a slideshow of still images

Interface

Wired

Digital terminal
(Hi-Speed USB compliant) Micro USB
HDMI OUT terminal Type D

Wireless

NFC NFC Forum Type3/4 Tag compliant
(Dynamic)

Bluetooth

Compliance standards Bluetooth Ver. 4.1
(Bluetooth low energy technology)
Transmission scheme GFSK modulation scheme

Wi-Fi

Compliance standards IEEE 802.11b/g/n
Transmission frequency
Frequency 2.4 GHz
Channels 1 – 11

Security

Infrastructure mode WPA2-PSK (AES/TKIP),
WPA-PSK (AES/TKIP), WEP
* Wi-Fi Protected Setup compliant

Camera access point mode WPA2-PSK (AES)
Ad hoc mode WPA2-PSK (AES)

Before Use

Basic Guide

Advanced Guide

Camera Basics

Auto Mode /
Hybrid Auto Mode

Other Shooting Modes

P Mode

Tv, Av, M, and C Mode

Playback Mode

Wireless Features

Setting Menu

Accessories

Appendix

Index



Operating Environment

TemperatureMin. 0 °C, max. 40 °C
(Min. 32 °F, max. 104 °F)

Dimensions (CIPA Compliant)

WApprox. 115.0 mm (approx. 4.5 in.)

HApprox. 77.9 mm (approx. 3.1 in.)

DApprox. 51.4 mm (approx. 2.0 in.)

Weight (CIPA Compliant)

Camera Body OnlyApprox. 375 g (approx. 13.2 oz.)

Including Battery Pack, Memory CardApprox. 399 g (approx. 14.1 oz.)

Battery Pack NB-13L

Type: Rechargeable lithium-ion battery
Nominal voltage: 3.6 V DC
Nominal capacity: 1250 mAh
Charging cycles: Approx. 300 times
Operating temperatures: 0 – 40 °C (32 – 104 °F)

Battery Charger CB-2LH/CB-2LHE

Rated input: 100 – 240 V AC (50/60 Hz)
0.09 A (100 V) – 0.06 A (240 V)
4.2 V DC, 0.7 A
Rated output:
Charging time: Approx. 2 hr. 10 min. (when using NB-13L)
Operating temperatures: 5 – 40 °C (41 – 104 °F)

Compact Power Adapter CA-DC30/CA-DC30E

Rated input: 100 – 240 V AC (50/60 Hz)
0.07 A (100 V) – 0.045 A (240 V)
Rated output: 5.0 V DC, 0.55 A
Charging time: Approx. 2 hr. 50 min.* (when charged with NB-13L in the camera)
*Charging time varies greatly depending on the remaining battery level.
Operating temperatures: 5 – 40 °C (41 – 104 °F)

- Size, weight, and number of shots available are based on measurement guidelines of the Camera & Imaging Products Association (CIPA).
- Under some shooting conditions, the number of shots and recording time may be less than mentioned above.
- Number of shots/time with a fully charged battery pack.

Before Use

Basic Guide

Advanced Guide

Camera Basics

Auto Mode /
Hybrid Auto Mode

Other Shooting Modes

P Mode

Tv, Av, M, and C Mode

Playback Mode

Wireless Features

Setting Menu

Accessories

Appendix

Index



Index

A

Accessories 181
AEB shooting 81
AE lock 78
AF frames 91
AF lock 95
AF method 91
Art bold effect (shooting mode) 63
Aspect ratio 49
Auto Lighting Optimizer 82
Auto mode (shooting mode) 23, 35
Auto power down 27
Av (shooting mode) 100

B

Batteries → Date/time
(date/time battery)
Battery charger 181
Battery pack
 Charging 19
 Eco mode 173
 Level 204
 Power saving 27
Bluetooth 141

C

Camera
 Resetting 177
Camera access point mode 148
Camera Connect 142
CameraWindow 189
CANON iIMAGE GATEWAY 154
Clock 34
Color (white balance) 83

Compression 50
Connecting via an access point 150
Continuous shooting 40, 44
Creative filters 130
Cropping 129, 192
Custom white balance 83

D

Date/time
 Changing 22
 Date/time battery 22
 Settings 21
 World clock 174
Defaults → Resetting
Digital tele-converter 91
Digital zoom 42
Display language 23
DPOF 194
Dragging 17

E

Eco mode 173
Editing
 Cropping 129
 Red-eye correction 131
 Resizing images 128
Editing or erasing connection
 information 167
Electronic level 52
Erasing 123
Erasing all 124
Error messages 202

Exposure

AE lock 78
Compensation 78
FE lock 97

F

Face ID 45
Face select 94
Favorites 126
FE lock 97
File numbering 170
Fireworks (shooting mode) 57
Fish-eye effect (shooting mode) 63
Flash
 Deactivating flash 96
 Flash exposure compensation 97
 On 96
 Slow synchro 56
Focus bracketing 90
Focus check 120
Focusing
 AF frames 91
 AF lock 95
 MF peaking 90
 Servo AF 93
 Touch AF 95
Focus lock 91
Focus range
 Macro 88
 Manual focus 89
 Quick 58
 Underwater macro 58
FUNC. menu layout 108

G

Geotagging images 164
GPS information display 113
Grainy B/W (shooting mode) 62

H

Handheld night scene
(shooting mode) 57
HDMI cable 183
High dynamic range
(shooting mode) 66
High ISO speed noise reduction 80
Hybrid Auto (shooting mode) 37

I

Image quality → Compression
Images
 Display period 55
 Erasing 123
 Playback → Viewing
 Protecting 121
Image stabilization 53, 98
Image Sync 162
Indicator 33, 54, 55
ISO speed 80

J

Jump display 117

M

Macro (focus range) 88
Magnified display 120
Manual focus (focus range) 89
Manual (movie mode) 102
Memory cards 2
Menu
 Basic operations 31
 Table 207
Metering mode 79
Miniature effect (shooting mode) 65

Before Use

Basic Guide

Advanced Guide

Camera Basics

Auto Mode /
Hybrid Auto Mode

Other Shooting Modes

P Mode

Tv, Av, M, and C Mode

Playback Mode

Wireless Features

Setting Menu

Accessories

Appendix

Index



Movies
Editing 134
Image quality (recording pixels/
frame rate) 51

N
ND filter 81
Neck strap → Strap

P
P (shooting mode) 77
Package contents 2
Panning (shooting mode) 61
Panoramic shot (shooting mode) 60
Photobook set-up 197
PictBridge 182, 191
Picture Style 85
Playback → Viewing
Portrait (shooting mode) 56
Power 181 → Battery charger
→ Battery pack
Power saving 27
Printing 191 → Printing
Program AE 77
Protecting 121

Q
Quick (focus range) 58
Quick Set menu 209

R
RAW 50
RAW image processing 132
Recording pixels (image size) 50
Red-eye correction 131
Remote live view shooting 165
Resetting 177

Resizing images 128
Rotating 125

S
Saving images to a computer 189
Screen
Display language 23
Icons 204, 205
Menu → Quick Set menu, Menu
SD/SDHC/SDXC memory cards
→ Memory cards
Searching 116
Self portrait (shooting mode) 59
Self-timer 42
2-second self-timer 43
Customizing the self-timer 43
Sending images 159
Sending images to another
camera 159
Sending images to a smartphone 142
Sending images to Web services 154
Servo AF 93
Shooting
Shooting date/time → Date/time
Shooting information 204
Shooting information
Long exposure 103
Short clips (movie mode) 74
Slideshow 121
Smooth skin (shooting mode) 60
Soft focus (shooting mode) 62
Software
Installation 149, 189
Saving images to a computer 189
Sounds 175
Standard (movie mode) 72

Star (shooting mode) 67
Star nightscape
(shooting mode) 67
Star time-lapse movie
(shooting mode) 68
Star trails (shooting mode) 67
Story Highlights 136
Strap 2

T
Terminal 183, 191
Time-lapse movie (shooting mode) 75
Touch Actions 127
Touch AF 95
Touching 17
Touch-screen panel 17
Touch Shutter 44
Toy camera effect (shooting mode) 64
Traveling with the camera 174
Troubleshooting 198
TV display 183
Tv (shooting mode) 99

U
Underwater macro (focus range) 58
Underwater (shooting mode) 58

V
Viewing 24
Image search 116
Index display 115
Jump display 117
Magnified display 120
Single-image display 24
Slideshow 121
TV display 183

W
Water painting effect
(shooting mode) 64
White balance (color) 83
Wi-Fi 141
Wind filter 74
Wireless features 141
World clock 174

Z
Zoom 23, 36, 42, 88

Before Use

Basic Guide

Advanced Guide

Camera Basics

Auto Mode /
Hybrid Auto Mode

Other Shooting Modes

P Mode

Tv, Av, M, and C Mode

Playback Mode

Wireless Features

Setting Menu

Accessories

Appendix

Index



Precautions for Wireless Features (Wi-Fi, Bluetooth, or Others)

- Countries and Regions Permitting Wireless Function Use
 - Use of wireless functions is restricted in some countries and regions, and illegal use may be punishable under national or local regulations. To avoid violating wireless regulations, visit the Canon website to check where use is allowed.
Note that Canon cannot be held liable for any problems arising from wireless function use in other countries and regions.
- Doing any of the following may incur legal penalties:
 - Altering or modifying the product
 - Removing the certification labels from the product
- Before goods or technologies in the camera regulated by the Foreign Exchange and Foreign Trade Act are exported (which includes bringing them outside Japan or showing them to non-residents in Japan), export or service transaction permission may be required from the Japanese government.
- Because this product includes American encryption items, it falls under U.S. Export Administration Regulations, and cannot be exported to or brought into a country under U.S. trade embargo.
- Be sure to make notes of the Wi-Fi settings you use.
The wireless settings saved to this product may change or be erased due to incorrect operation of the product, the effects of radio waves or static electricity, or accident or malfunction.
Please note that Canon accepts no responsibility for direct or indirect damages or loss of earnings resulting from a degradation or disappearance of content.
- When transferring ownership, disposing of the product, or sending it for repair, restore the default wireless settings by erasing any settings you have entered.

- Canon will not make compensation for damages resulting from loss or theft of the product.
Canon accepts no responsibility for damages or loss resulting from unauthorized access or use of target devices registered on this product due to loss or theft of the product.
- Be sure to use the product as directed in this guide.
Be sure to use the wireless function of this product within the guidelines noted in this guide. Canon accepts no responsibility for damages or loss if the function and product are used in ways other than as described in this guide.
- Do not use the wireless function of this product near medical equipment or other electronic equipment.
Use of the wireless function near medical equipment or other electronic equipment may affect operation of those devices.

Radio Wave Interference Precautions

- This product may receive interference from other devices that emit radio waves. To avoid interference, be sure to use this product as far away as possible from such devices, or avoid using the devices at the same time as this product.

Security Precautions

Because Wi-Fi uses radio waves to transmit signals, security precautions more stringent than when using a LAN cable are required. Keep the following points in mind when using Wi-Fi.

- Only use networks you are authorized to use.
This product searches for Wi-Fi networks in the vicinity and displays the results on the screen. Networks you are not authorized to use (unknown networks) may also be displayed. However, attempting to connect to or using such networks could be regarded as unauthorized access. Be sure to use only networks you are authorized to use, and do not attempt to connect to other unknown networks.

Before Use

Basic Guide

Advanced Guide

Camera Basics

Auto Mode /
Hybrid Auto Mode

Other Shooting Modes

P Mode

Tv, Av, M, and C Mode

Playback Mode

Wireless Features

Setting Menu

Accessories

Appendix

Index



If security settings have not been properly set, the following problems may occur.

- **Transmission monitoring**
Third parties with malicious intent may monitor Wi-Fi transmissions and attempt to acquire the data you are sending.
- **Unauthorized network access**
Third parties with malicious intent may gain unauthorized access to the network you are using to steal, modify, or destroy information. Additionally, you could fall victim to other types of unauthorized access such as impersonation (where someone assumes an identity to gain access to unauthorized information) or springboard attacks (where someone gains unauthorized access to your network as a springboard to cover their tracks when infiltrating other systems).

To prevent these types of problems from occurring, be sure to thoroughly secure your Wi-Fi network.

Only use this camera's Wi-Fi function with a proper understanding of Wi-Fi security, and balance risk and convenience when adjusting security settings.

Third-Party Software

- **expat.h**
Copyright (c) 1998, 1999, 2000 Thai Open Source Software Center Ltd

Permission is hereby granted, free of charge, to any person obtaining a copy of this software and associated documentation files (the "Software"), to deal in the Software without restriction, including without limitation the rights to use, copy, modify, merge, publish, distribute, sublicense, and/or sell copies of the Software, and to permit persons to whom the Software is furnished to do so, subject to the following conditions:

The above copyright notice and this permission notice shall be included in all copies or substantial portions of the Software.

THE SOFTWARE IS PROVIDED "AS IS", WITHOUT WARRANTY OF ANY KIND, EXPRESS OR IMPLIED, INCLUDING BUT NOT LIMITED TO THE WARRANTIES OF MERCHANTABILITY, FITNESS FOR A PARTICULAR PURPOSE AND NONINFRINGEMENT. IN NO EVENT SHALL THE AUTHORS OR COPYRIGHT HOLDERS BE LIABLE FOR ANY CLAIM, DAMAGES OR OTHER LIABILITY, WHETHER IN AN ACTION OF CONTRACT, TORT OR OTHERWISE, ARISING FROM, OUT OF OR IN CONNECTION WITH THE SOFTWARE OR THE USE OR OTHER DEALINGS IN THE SOFTWARE.

- **AES-128 Library**
Copyright (c) 1998-2008, Brian Gladman, Worcester, UK. All rights reserved.

LICENSE TERMS

The redistribution and use of this software (with or without changes) is allowed without the payment of fees or royalties provided that:

1. source code distributions include the above copyright notice, this list of conditions and the following disclaimer;
2. binary distributions include the above copyright notice, this list of conditions and the following disclaimer in their documentation;
3. the name of the copyright holder is not used to endorse products built using this software without specific written permission.

DISCLAIMER

This software is provided 'as is' with no explicit or implied warranties in respect of its properties, including, but not limited to, correctness and/or fitness for purpose.

Before Use

Basic Guide

Advanced Guide

Camera Basics

Auto Mode /
Hybrid Auto Mode

Other Shooting Modes

P Mode

Tv, Av, M, and C Mode

Playback Mode

Wireless Features

Setting Menu

Accessories

Appendix

Index



Personal Information and Security Precautions

If personal information and/or Wi-Fi security settings, such as passwords, etc., are saved on the camera, please be aware that such information and settings may still remain in the camera.

When transferring the camera to another person, disposing of it, or sending it for repair, be sure to take the following measures to prevent the leakage of such information and settings.

- Erase registered personal information by choosing [Erase Info] in the Face ID settings.
- Erase registered Wi-Fi security information by choosing [Reset Settings] in the Wi-Fi settings.

Trademarks and Licensing

- Microsoft and Windows are trademarks or registered trademarks of Microsoft Corporation in the United States and/or other countries.
- Macintosh and Mac OS are trademarks of Apple Inc., registered in the U.S. and other countries.
- App Store, iPhone, and iPad are trademarks of Apple Inc.
- The SDXC logo is a trademark of SD-3C, LLC.
- HDMI, the HDMI logo and High-Definition Multimedia Interface are trademarks or registered trademarks of HDMI Licensing, LLC.
- Wi-Fi®, Wi-Fi Alliance®, WPA™, WPA2™ and Wi-Fi Protected Setup™ are trademarks or registered trademarks of the Wi-Fi Alliance.
- The Bluetooth® word mark and logos are registered trademarks owned by Bluetooth SIG, Inc. and any use of such marks by Canon Inc. is under license. Other trademarks and trade names are those of their respective owners.
- The N-Mark is a trademark or registered trademark of NFC Forum, Inc. in the United States and in other countries.
- All other trademarks are the property of their respective owners.
- This device incorporates exFAT technology licensed from Microsoft.

- This product is licensed under AT&T patents for the MPEG-4 standard and may be used for encoding MPEG-4 compliant video and/or decoding MPEG-4 compliant video that was encoded only (1) for a personal and non-commercial purpose or (2) by a video provider licensed under the AT&T patents to provide MPEG-4 compliant video. No license is granted or implied for any other use for MPEG-4 standard.

Disclaimer

- Unauthorized reproduction of this guide is prohibited.
- All measurements based on Canon testing standards.
- Information subject to change without notice, as are product specifications and appearance.
- Illustrations and screenshots in this guide may differ slightly from the actual equipment.
- The above items notwithstanding, Canon cannot be held liable for any loss arising from the use of this product.

Before Use

Basic Guide

Advanced Guide

Camera Basics

Auto Mode /
Hybrid Auto Mode

Other Shooting Modes

P Mode

Tv, Av, M, and C Mode

Playback Mode

Wireless Features

Setting Menu

Accessories

Appendix

Index

