

Smart-UPS™ VT Rack Mounted

20–30 kVA 208/480 V

Operation

06/2015



Legal Information

The Schneider Electric brand and any registered trademarks of Schneider Electric Industries SAS referred to in this guide are the sole property of Schneider Electric SA and its subsidiaries. They may not be used for any purpose without the owner's permission, given in writing. This guide and its content are protected, within the meaning of the French intellectual property code (Code de la propriété intellectuelle français, referred to hereafter as "the Code"), under the laws of copyright covering texts, drawings and models, as well as by trademark law. You agree not to reproduce, other than for your own personal, noncommercial use as defined in the Code, all or part of this guide on any medium whatsoever without Schneider Electric's permission, given in writing. You also agree not to establish any hypertext links to this guide or its content. Schneider Electric does not grant any right or license for the personal and noncommercial use of the guide or its content, except for a non-exclusive license to consult it on an "as is" basis, at your own risk. All other rights are reserved.

Electrical equipment should be installed, operated, serviced, and maintained only by qualified personnel. No responsibility is assumed by Schneider Electric for any consequences arising out of the use of this material.

As standards, specifications, and designs change from time to time, please ask for confirmation of the information given in this publication.

Table of Contents

Important Safety Information	5
Safety Precautions	6
Battery Safety	6
Overview	8
User Interface (Front).....	8
User Interface (Rear)	8
Display Interface.....	9
Operate the Display Interface.....	10
Menu Tree	10
Operation	12
Operation Modes.....	12
Normal Operation	12
Battery Operation.....	12
Static Bypass Operation	12
Internal Bypass Operation	12
External Maintenance Bypass Operation (Optional).....	12
Operation Procedures.....	13
Turn into Internal Bypass Operation from Normal Operation	13
Turn into Normal Operation from Internal Bypass Operation	14
Perform a Total Power Off.....	14
Perform a Restart	16
Turn Load Off – Disconnect the UPS Output to the Load Equipment.....	16
Turn Load On – Connect the UPS Output to the Load Equipment	17
Connect the Load to the PDU.....	17
Disconnect the Load from the PDUs.....	18
View the Status Screens.....	18
View Log	19
View Statistics	19
View Diagnostics	19
Configuration	20
Set the Clock.....	20
Set the Alarm Thresholds.....	20
Change the Beeper Setup, the Contrast, and the Language.....	22
Beeper Setup	22
Contrast.....	22
Language.....	22
Maintenance	23
Parts Replacement	23
Determine if you need a Replacement Part	23
Return Parts to Schneider Electric.....	23
User-Replaceable Parts (Only by Qualified Personnel)	23
Replace a Network Management Card	24
Replace a Battery Module.....	24
Troubleshooting	29
Status and Alarm Messages	29
Display Messages.....	29

Important Safety Information

Read these instructions carefully and look at the equipment to become familiar with it before trying to install, operate, service or maintain it. The following safety messages may appear throughout this manual or on the equipment to warn of potential hazards or to call attention to information that clarifies or simplifies a procedure.



The addition of this symbol to a “Danger” or “Warning” safety message indicates that an electrical hazard exists which will result in personal injury if the instructions are not followed.



This is the safety alert symbol. It is used to alert you to potential personal injury hazards. Obey all safety messages with this symbol to avoid possible injury or death.

⚠ DANGER
<p>DANGER indicates a hazardous situation which, if not avoided, will result in death or serious injury.</p> <p>Failure to follow these instructions will result in death or serious injury.</p>
⚠ WARNING
<p>WARNING indicates a hazardous situation which, if not avoided, could result in death or serious injury.</p> <p>Failure to follow these instructions can result in death, serious injury, or equipment damage.</p>
⚠ CAUTION
<p>CAUTION indicates a hazardous situation which, if not avoided, could result in minor or moderate injury.</p> <p>Failure to follow these instructions can result in injury or equipment damage.</p>
NOTICE
<p>NOTICE is used to address practices not related to physical injury. The safety alert symbol shall not be used with this type of safety message.</p> <p>Failure to follow these instructions can result in equipment damage.</p>

Please Note

Electrical equipment should only be installed, operated, serviced, and maintained by qualified personnel. No responsibility is assumed by Schneider Electric for any consequences arising out of the use of this material.

A qualified person is one who has skills and knowledge related to the construction, installation, and operation of electrical equipment and has received safety training to recognize and avoid the hazards involved.

Safety Precautions

⚠ DANGER

HAZARD OF ELECTRICAL SHOCK, EXPLOSION OR ARC FLASH

All safety instructions in this document must be read, understood and followed.

Failure to follow these instructions will result in death or serious injury.

⚠ DANGER

HAZARD OF ELECTRICAL SHOCK, EXPLOSION OR ARC FLASH

After the UPS system has been electrically wired, do not start up the system. Startup must only be performed by Schneider Electric.

Failure to follow these instructions will result in death or serious injury.

Battery Safety

⚠ DANGER

HAZARD OF ELECTRIC SHOCK, EXPLOSION OR ARC FLASH

- Battery circuit breakers must be installed according to the specifications and requirements as defined by Schneider Electric.
- Servicing of batteries must only be performed or supervised by qualified personnel knowledgeable of batteries and the required precautions. Keep unqualified personnel away from batteries.
- Disconnect charging source prior to connecting or disconnecting battery terminals.
- Do not dispose of batteries in a fire as they can explode.
- Do not open, alter, or mutilate batteries. Released electrolyte is harmful to the skin and eyes. It may be toxic.

Failure to follow these instructions will result in death or serious injury.

⚠ DANGER

HAZARD OF ELECTRIC SHOCK, EXPLOSION, OR ARC FLASH

Batteries can present a risk of electric shock and high short-circuit current. The following precautions must be observed when working on batteries

- Remove watches, rings, or other metal objects.
- Use tools with insulated handles.
- Wear protective glasses, gloves and boots.
- Do not lay tools or metal parts on top of batteries.
- Disconnect the charging source prior to connecting or disconnecting battery terminals.
- Determine if the battery is inadvertently grounded. If inadvertently grounded, remove source from ground. Contact with any part of a grounded battery can result in electric shock. The likelihood of such shock can be reduced if such grounds are removed during installation and maintenance (applicable to equipment and remote battery supplies not having a grounded supply circuit).

Failure to follow these instructions will result in death or serious injury.

⚠ DANGER**HAZARD OF ELECTRIC SHOCK, EXPLOSION, OR ARC FLASH**

When replacing batteries, always replace with the same type and number of batteries or battery packs.

Failure to follow these instructions will result in death or serious injury.

⚠ CAUTION**RISK OF EQUIPMENT DAMAGE**

- Wait until the system is ready to be powered up before installing batteries in the system. The time duration from battery installation until the UPS system is powered up must not exceed 72 hours or 3 days.
- Batteries must not be stored more than six months due to the requirement of recharging. If the UPS system remains de-energized for a long period, we recommend that you energize the UPS system for a period of 24 hours at least once every month. This charges the batteries, thus avoiding irreversible damage.

Failure to follow these instructions can result in injury or equipment damage.

Overview

User Interface (Front)

Front View of the UPS Cabinet

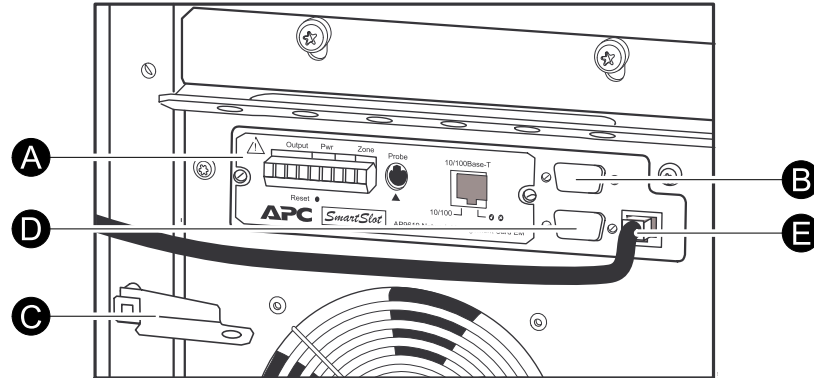

- A. Network management card with temperature sensor: Used for remote system control and monitoring, e-mail notifications, etc. For configuration and use, refer to the separate network management card manual shipped with the UPS.
- B. Computer-interface port for the connection of computers with Schneider Electric Powerchute® software.
- C. Internal mechanical bypass lever: Used to bypass the upstream utility/mains power around the UPS to support the load directly = internal bypass operation.
- D. Service port (for Schneider Electric maintenance personnel only).
- E. Display port for the connection of display communication cable.

User Interface (Rear)

The power distribution unit (PDU) is installed behind the rear cover of the UPS.

Rear View of the UPS Cabinet

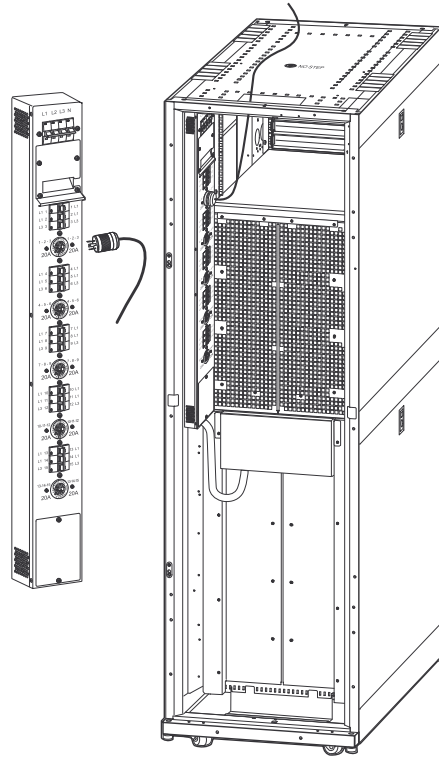

Display Interface

The four LEDs to the left of the display indicate the operational status of the UPS. The five navigation keys to the right are used to select and open menu items, to access information, change system parameters, and to get context-sensitive help.

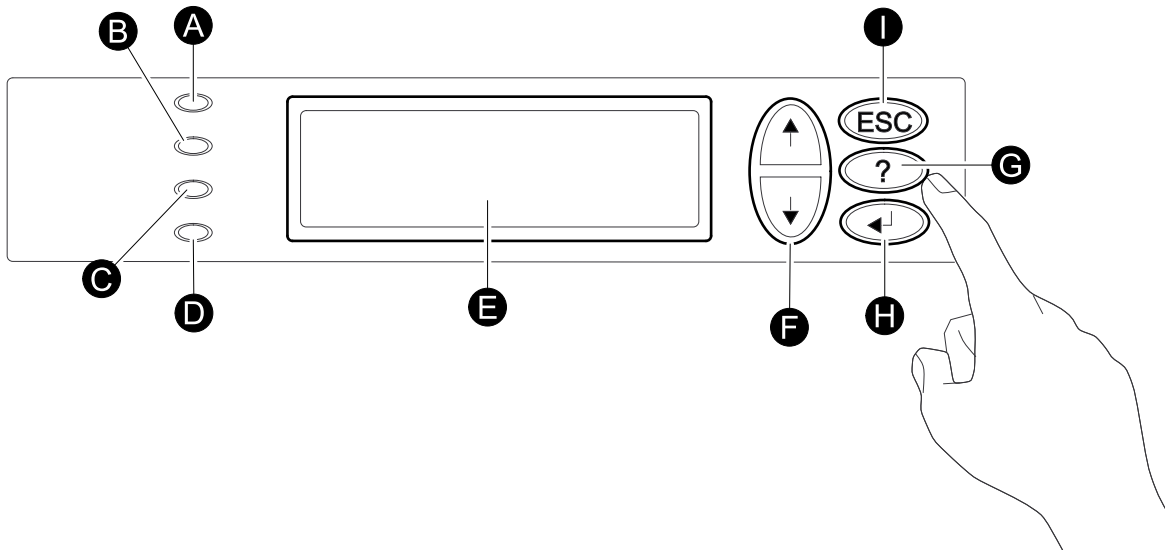

A	LOAD ON	When the green LED is lit, the UPS provides power to the load equipment.
B	ON BATT	When the yellow LED is lit, power flows from the batteries to the load.
C	BYPASS	When the yellow LED is lit, power to the load is supplied through bypass.
D	FAULT	When the red LED is lit, a fault condition exists.
E	LCD screen	Displays alarms, status data, instructional help, and configuration items.
F	Arrow keys	Scrolls through and select menu items.

G	Help key	Opens context-sensitive help.
H	Enter key	Opens menu items and confirms changes to the system parameters.
I	ESC key	Returns to the previous screen displayed.

Operate the Display Interface

The Overview Screen is the main entrance to the user functions of the display interface. The arrow keys take you from one screen to another.

The Enter key takes you from the Overview Screen to the Main Screen.

From the Main Screen it is possible to command, configure, and monitor the system through the sub menu screens: **Control**, **Status**, **Setup**, **LCM**, **Logging**, **Display**, **Diags**, and **Help** (see the menu tree). The selector arrow (→) is controlled by the arrow keys. The selector arrow (→) marks the item you can open by pressing Enter key.

Overview Screen

```
Chrg xxx%
Load xxx%
xxxVin xxxVout xxHz
Runtime: xxhr xxmin
```

Main Screen

```
→ Control  Logging
   Status   Display
   Setup    Diags
   LCM      Help
```

Menu Tree

NOTE: The display provides access to more functions than described in this manual. Those functions should not be accessed without the assistance of Schneider Electric Customer Support in order to avoid unwanted load impacts. If you by accident go beyond the functions described, press **ESC** to return to previous screens.

The menu tree provides a quick overview of the functions and views you may access.

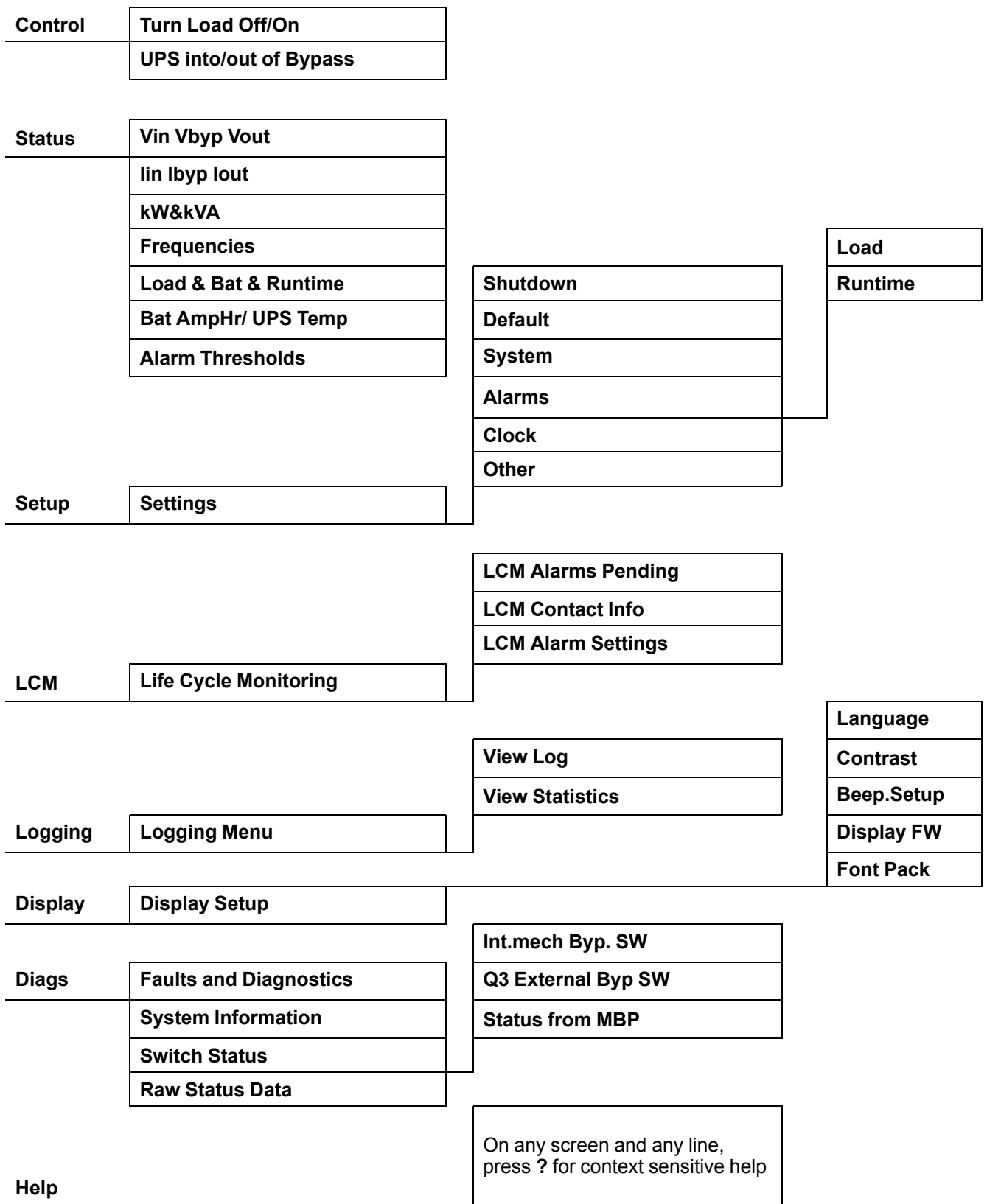

Operation

Operation Modes

The UPS has different operation modes. If the installation includes an external maintenance bypass, external maintenance bypass operation mode will also be available.

Normal Operation

The UPS converts utility/mains power to conditioned power for the connected load.

Battery Operation

The UPS provides power to the connected load from its internal and (if available) external batteries for a finite period. The UPS transfers to battery operation if the supply of utility/mains power fails, or is outside the pre-defined limits.

Static Bypass Operation

The UPS transfers to static bypass operation following a command on the display or after a short or heavy overload on the output of the UPS, or if normal and battery modes are unavailable. During static bypass operation the utility/mains power is sent through internal radio frequency interference (RFI) filters to the load, bypassing the internal power converters. Battery back-up is not available in static bypass operation even though the batteries are in place.

Internal Bypass Operation

Internal bypass keeps the load supplied with utility/mains power during maintenance of the UPS power sections. In internal bypass operation, utility/mains power is sent directly to the connected load bypassing all internal UPS functions and filters. Battery back-up is not available in internal bypass operation even though the batteries are in place.

External Maintenance Bypass Operation (Optional)

The UPS can be connected to an optional external maintenance bypass. When activated, this panel bypasses the entire UPS cabinet, feeding utility/mains power directly to the load. An activated external maintenance bypass **completely** isolates the UPS and allows maintenance to be performed.

Operation Procedures

Turn into Internal Bypass Operation from Normal Operation

⚠ DANGER

HAZARD OF ELECTRIC SHOCK, EXPLOSION OR ARC FLASH

In bypass operation the batteries are still powered. If a total power off is required, the load must be off, and the batteries must be pulled out to the red disconnect line.

Failure to follow these instructions will result in death or serious injury.

⚠ DANGER

HAZARD OF ELECTRIC SHOCK, EXPLOSION OR ARC FLASH

The load is not protected by the UPS and the power is not conditioned when the internal mechanical bypass lever is activated.

Failure to follow these instructions will result in death or serious injury.

1. If the UPS is running and controllable through the display, carry out steps 2-5. If not, go directly to step 6.
2. From the Overview screen, press the Enter key.
3. Go to **Control > UPS into Bypass** by using the arrow keys and press the Enter key.

```
→ UPS into Bypass
   Do Self test
   Simulate Power Fail
   Start Runtime Cal
```

4. Go to **YES, UPS into Bypass** by using the arrow keys and press the Enter key.

```
Confirm:
UPS into Bypass
NO, ABORT
→ YES, UPS into Bypass
```

5. Check that the UPS is in bypass. The green (**LOAD ON**) and the yellow (**BYPASS**) LEDs are illuminated.

⚠ DANGER

HAZARD OF ELECTRIC SHOCK, EXPLOSION OR ARC FLASH

For safety reasons, only qualified personnel is allowed to perform the following steps.

Failure to follow these instructions will result in death or serious injury.

6. Remove the front panel from the UPS.

- Turn the internal mechanical bypass lever upwards to activate it. The load will now be supported directly by utility/mains power.

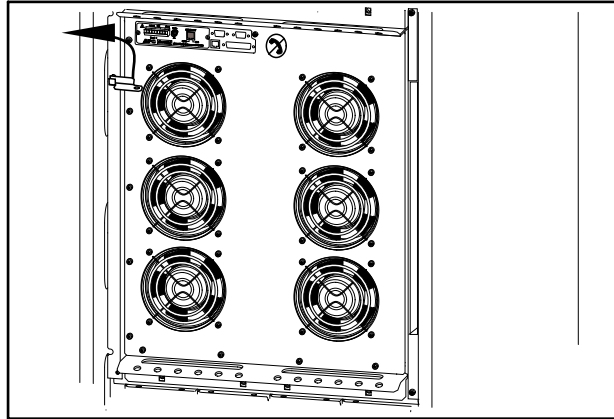

Turn into Normal Operation from Internal Bypass Operation

⚠ DANGER

HAZARD OF ELECTRIC SHOCK, EXPLOSION, OR ARC FLASH

Never attempt to turn the UPS into normal operation till you have verified that there are no internal UPS faults.

Failure to follow these instructions will result in death or serious injury.

- Check that the UPS is in bypass. The green (LOAD ON) and the yellow (BYPASS) LEDs are illuminated.
- Turn the mechanical bypass lever downwards into a horizontal position to deactivate the internal bypass operation.
- If the UPS has not returned to normal operation: Press the **ESC** key to return to the previous menu and turn out of bypass from the display via **Control > UPS out of bypass > Yes, UPS out of bypass**.
- Check that the UPS is in normal operation. The yellow **BYPASS** LED turns off and the green **LOAD ON** LED remains illuminated.

Perform a Total Power Off

NOTE: In order to carry out this procedure the load supported by the UPS must be turned off.

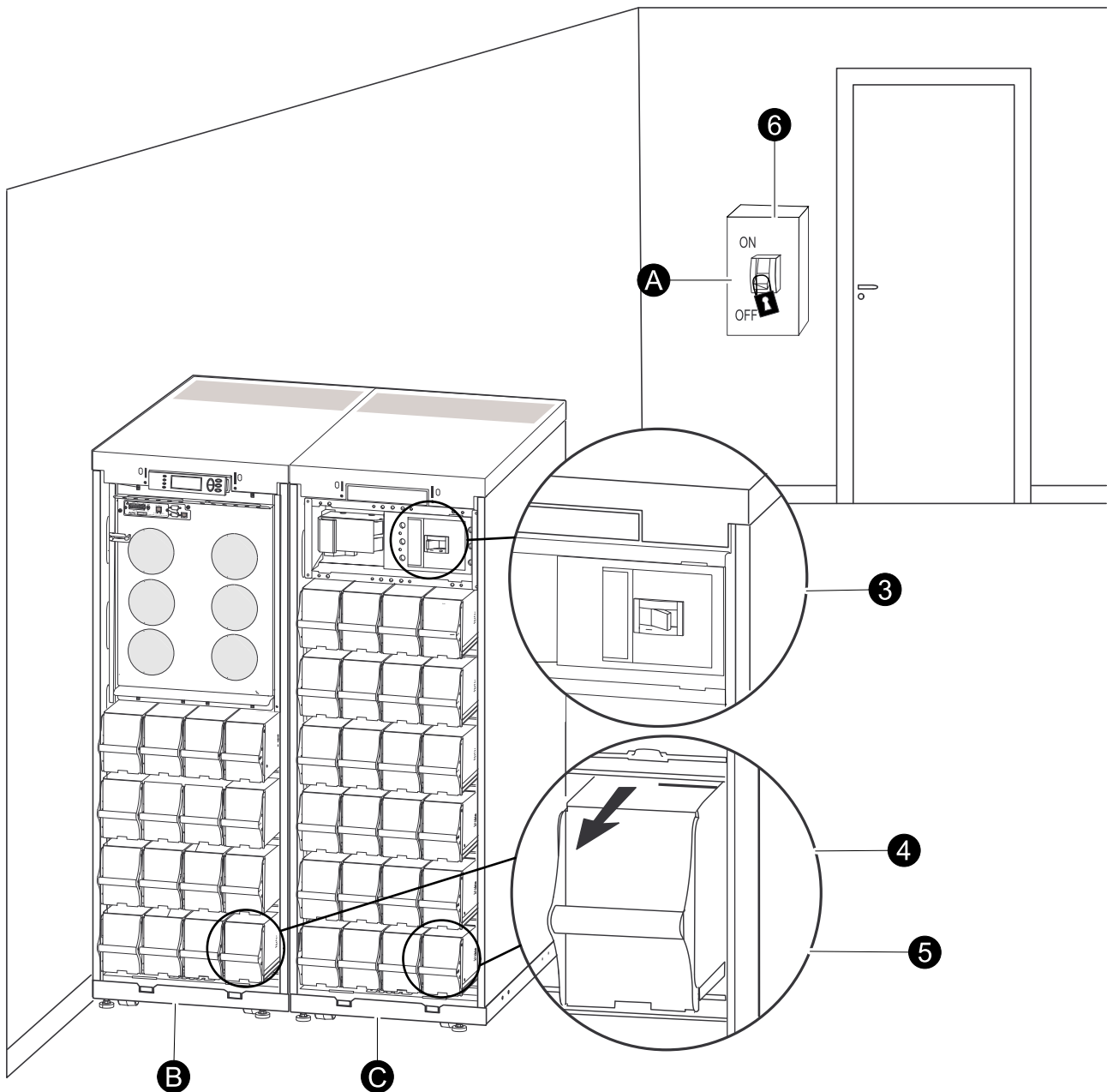

- A. Utility/mains breaker
- B. UPS
- C. Modular battery cabinet

1. Check that the load which is supported by the UPS is turned OFF.
2. From the UPS: Turn load OFF from the display via **Control > Turn Load Off > Yes, Turn Load Off**.
3. From the modular battery cabinet(s) (if available): Set the DC disconnect switch (es) to position OFF.
4. From the UPS: Disconnect the batteries (if available) by pulling them out to the red disconnect line shown on each battery unit.
5. From the modular battery cabinet(s) (if available): Disconnect the batteries by pulling them out to the red disconnect line shown on each battery unit.
6. Set the utility/mains breaker to position OFF or LOCKED-OUT. If the UPS has dual utility/mains supply, set both supplies to position OFF or LOCKED-OUT.

Post-requisite:

NOTE: The lockout procedures at the utility/mains breaker must be followed. If necessary, install a padlock.

NOTE: For details on how to remove battery locks, see the section *Replace a Battery Module*, page 24 and hereunder *Remove and Install Battery Locks*, page 26.

Perform a Restart

1. Set the utility/mains breaker to position ON.
2. If your installation includes a modular battery cabinet with a DC disconnect switch, set the DC disconnect switch to position ON.

NOTE: Wait approximately 30 seconds for the system to boot up and carry out a self-test.

After system boot-up, the display will automatically ask you to confirm/select voltage and frequency as shown in the following.

3. When the **Confirm Voltage** prompt appears on the screen, go to the desired voltage using the arrow keys and press the Enter key.
4. When the prompt **Apply load** appears, go to **Yes** using the UP/DOWN navigation keys and press the Enter key if you want the UPS to apply load to the output now. (If you do not want a UPS load output at this point, go to **No**).
5. The green (LOAD ON) LED is now lit. Press the **ESC** key two times and the display will return to the Overview Screen.

NOTE: The UPS is now ready to support the load.

NOTE: If the UPS system during a start-up detects an input frequency different from what is already set, then the user will be asked to choose the detected frequency. The system will not change frequency by itself. For safety reasons, the input frequency can only be changed by the user. The auto-detection on frequency-feature is only applicable in a single system start-up. If a problem occurs call Schneider Electric.

Turn Load Off – Disconnect the UPS Output to the Load Equipment

⚠ DANGER

HAZARD OF ELECTRIC SHOCK, EXPLOSION, OR ARC FLASH

Disconnecting the UPS output to the load does NOT de-energize the UPS. Always follow the *Perform a Total Power Off*, page 14 procedure if you need to de-energize the UPS.

Failure to follow these instructions will result in death or serious injury.

1. From the Overview Screen, press the Enter key.
2. Go to **Control > Turn Load OFF > YES, Turn Load OFF** by using the arrow keys and press the Enter key.

```
Confirm:
Turn Load OFF
NO, ABORT
→ YES, Turn Load OFF
```

Turn Load On – Connect the UPS Output to the Load Equipment

1. From the Overview Screen, press the Enter key.
2. Go to **Control > Turn Load ON > Yes, Turn Load ON** by using the arrow keys and press the Enter key.

```

Confirm:
Turn Load OFF
NO, ABORT
→ YES, Turn Load ON
  
```

Connect the Load to the PDU

The Power Distribution Unit (PDU) at the rear of the UPS has six 3-phased breaker sets. The top 4-pole breaker set operates as a unit and protects any 3-phased equipment that may be connected to the PDU. This breaker unit will switch ON/OFF all 3 phases when operated (may supply several loads). Each of the five other breaker sets protects the 3-phased outlets beneath the actual breaker set.

NOTE: Share the load evenly between the 3 phases to avoid overloading one particular single phase. The total output capacity of the PDU is approximately twice the output capability of the UPS, meaning that the UPS would be over-loaded if all outlets were loaded to their rating. Load status on the individual phases can be found through the UPS display or through the web interface.

NOTE: Equipment connected to the 3-phased output can require overcurrent protection with a lower rating than the 3-phased output.

NOTE: For 3-phased outputs, the highest current is in the neutral conductor at non-linear loads (up to 173%).

1. Set the applicable breaker to the OFF position.
2. Insert the plug from the load into the outlet. Secure the plug by turning it to the right approximately 30°.
3. Set the applicable breaker to the ON position to supply the load.

Rear View of the UPS Cabinet

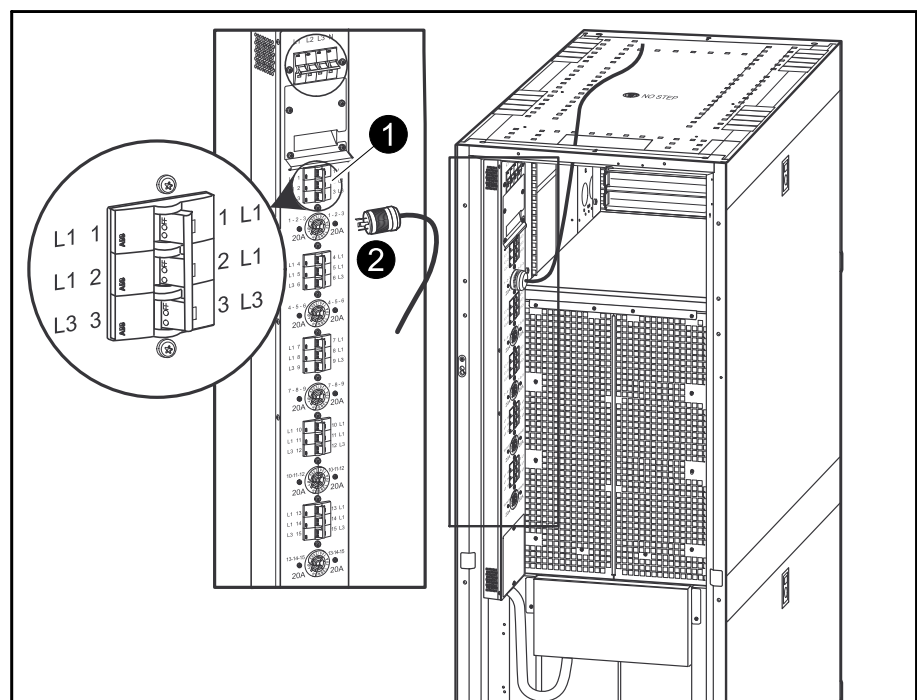

Disconnect the Load from the PDUs

1. Set the applicable breakers to the OFF position.

PDU Output Breaker Ratings

		20	50	63
Rear of unit	Ambient temperature in front of unit °C	Nominal Breaker Rating		
Free exhaust	20	17	42.5	53.55
Free exhaust	30	16	40.0	50.40
Free exhaust	40	15	37.5	47.25
Hot aisle exhaust	25	16	40.0	50.40

View the Status Screens

1. From the Overview Screen, press the Enter key.
2. Go to **Status** by using the arrow keys and press the Enter key.

```

Control  Logging
→ Status  Display
Setup    Diags
LCM      Help

```

3. Use the arrow keys to go through the below parameters and press the **ESC** key to return to the previous menus.

Status parameters	Description
Voltage on all phases	Utility/mains voltage (V), bypass voltage (V), and output voltage (V) for each phase.
Current on all phases	Utility/mains current (A), bypass current (A), and output current (A) for each phase.
kVA and kW	Apparent power (kVA) and real power (kW) generated by the UPS and the connected load.
Frequencies	Utility/mains frequency, bypass frequency, and output frequency in Hertz (Hz).
Load and batteries	Load: Percentage of the load in relation to the total UPS capacity.
Bat Voltage	Shows either the positive or negative half of the battery voltage (the lower value of the two will appear).
Bat Cap	Percentage charge on the batteries in relation to the total battery capacity. Runtime: The predicted runtime at the present load.
Batteries	Bat AmpHr: Battery capacity, including both external and internal batteries. UPS Temp: The highest external battery temperature.
Alarm thresholds	Load: An alarm will be set when the load is above the threshold level. Runtime: An alarm will be set when the runtime is below the threshold level.

View Log

1. From the Overview Screen, press the Enter key.
2. Go to **Logging > View Log > On Line** by using the arrow keys and press the Enter key. Here you can see the 100 most recent UPS log events, and the logged details of the events, such as date, time of occurrence, and event number.

```
24-Sep 15:06:48 #15
Mains out of Range
→ On Line
```

The top line states date, time, and event number. Lines 2, 3, and 4 are part of the event list. To view the entire list: Use the arrow keys to go through the log events and press the Enter key to get a detailed description of a particular event.

View Statistics

1. From the Overview Screen, press the Enter key.
2. Go to **Logging > View Statistics** by using the arrow keys and press the Enter key. Here you can see statistics on the operation mode changes, the inverter time, and the duration of battery operation.

```
View log
Clear log
→ View statistics
```

View Diagnostics

1. From the Overview Screen, press the Enter key.
2. Go to **Diags > Fault & Diagnostics** by using the arrow keys and press the Enter key. Here you can see information given on alarms for use in troubleshooting.

```
→ Fault & Diagnostics
System Information
Switch status
Raw Status Data
```

NOTE: For more details on the **Fault and Diagnostics** screens, see the troubleshooting section .

Configuration

Set the Clock

The **Clock** menu changes the date and the clock settings and it time-stamps events in the event log. To avoid inaccuracies, change the clock-setting at daylight-saving time.

1. From the Overview Screen, press the Enter key.
2. Go to **Setup > Clock** by using the arrow keys and press the Enter key.

```
Settings:
Shutdown  Alarms
Default   → Clock
System    Other
```

3. Press the Enter key.

```
→ Date: 24-Sep-2010
   Time: 13:45:51
```

4. The day is now active. Use the arrow keys to set the date and press the Enter key.

```
→ Date: 24-Sep-2010
   Time: 13:28:00
```

5. The month is now active. Use the arrow keys to set the month, press the Enter key and do the same to set the year, and press the Enter key.

```
→ Date: 24-Sep-2010
   Time: 13:28:00
```

6. Press the DOWN arrow key to activate the **Time** line.

```
   Date: 24-Sep-2010
→ Time: 13:28:00
```

The procedure to change the **Time** features is the same as described for date, month, and year.

7. Press the **ESC** key when you want to exit this menu.

Set the Alarm Thresholds

NOTE: If the load level exceeds the preprogrammed threshold, the UPS will display a warning.

1. From the Overview Screen, press the Enter key.
2. Go to **Setup > Alarms** by using the arrow keys and press the Enter key.

```
Settings:
Shutdown → Alarms
Default   Clock
System    Other
```

3. Press the Enter key to activate the first threshold and use the arrow keys to set the threshold. Press the Enter key to confirm.

```
Alarm thresholds
→ Load: 20.0 kVA
   Runtime: 0 hr 0 min
```

4. Press the Enter key to activate the second threshold and use the arrow keys to set the threshold. Press the Enter key to confirm.

```
Alarm thresholds
   Load: 20.0 kVA
→ Runtime: 0 hr 0 min
```

5. Press the **ESC** key when you want to exit this menu.

Change the Beeper Setup, the Contrast, and the Language

Beeper Setup

Select **Display > Display Setup > Beeper setup** and use the arrow keys and the Enter key to set the beeper settings.

- **Never:** If you select this setting, the beeper will be active at internal UPS errors only.
- **PwrFail+30:** If you select this setting, the beeper will be active at internal UPS errors and at utility/mains or bypass errors. The beeper will only sound if the fault has been present for more than 30 seconds.
- **PwrFail:** If you select this setting, the beeper will be active at internal UPS errors and at utility/mains or bypass errors. The beeper will sound immediately when the error is occurring.
- **LOW BATT:** If you select this setting, the beeper will be active at internal UPS errors at utility/mains or bypass errors, at power failures, and at a low battery level (if the UPS runs in battery operation).

Contrast

Select **Display > Display Setup > Contrast** and use the arrow keys and the Enter key to select the contrast level. The lower the value, the darker the contrast.

Language

Select **Display > Display Setup > Language** and use the arrow keys and the Enter key to select the language.

Maintenance

Parts Replacement

Determine if you need a Replacement Part

To determine if you need a replacement part, contact Schneider Electric and follow the procedure below so that the representative can assist you promptly:

1. In the event of an alarm condition, scroll through the alarm lists, record the information, and provide it to the representative.
2. Write down the serial number of the unit so that you will have it easily accessible when you contact Schneider Electric.
3. If possible, call Schneider Electric from a telephone that is within reach of the display so that you can gather and report additional information to the representative.
4. Be prepared to provide a detailed description of the problem. A representative will help you solve the problem over the telephone, if possible, or will assign a return material authorization (RMA) number to you. If a module is returned to Schneider Electric, this RMA number must be clearly printed on the outside of the package.
5. If the unit is within the warranty period and has been started up by Schneider Electric, repairs or replacements will be performed free of charge. If it is not within the warranty period, there will be a charge.
6. If the unit is covered by a Schneider Electric service contract, have the contract available to provide information to the representative.

Return Parts to Schneider Electric

Call Schneider Electric to obtain an RMA number.

To return an inoperable part to Schneider Electric, pack the module in the original shipping materials, and return it by insured, prepaid carrier. The customer support representative will provide the destination address. If you no longer have the original shipping materials, ask the representative about obtaining a new set. Pack the module properly to avoid damage in transit. Never use styrofoam beads or other loose packaging materials when shipping a module. The module may settle in transit and become damaged. Enclose a letter in the package with your name, RMA number, address, a copy of the sales receipt, description of the problem, a phone number, and a confirmation for payment (if necessary).

NOTE: Damages sustained in transit are not covered under warranty.

User-Replaceable Parts (Only by Qualified Personnel)

Parts	Part Number
Battery module	SYBT4
Network management card with temperature sensor	AP9631
Temperature/humidity sensor	AP9512THBLK

Replace a Network Management Card

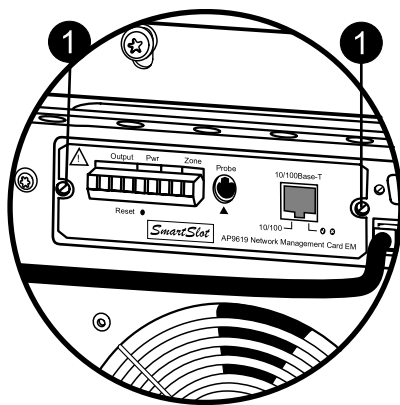

1. Loosen the two Torx screws (one on each side of the card).
2. Carefully pull out the card.
3. Install the new card.
4. Reattach the two Torx screws.

Replace a Battery Module

NOTE: Use two people to lift components weighing between 18–32 kg (40–70 lb).

⚠ DANGER

HAZARD OF ELECTRIC SHOCK, EXPLOSION OR ARC FLASH

- Servicing of batteries must only be performed or supervised by qualified personnel knowledgeable of batteries and the required precautions. Keep unqualified personnel away from batteries.
- Disconnect charging source prior to connecting or disconnecting battery terminals.
- Do not dispose of batteries in a fire as they can explode.
- Do not open, alter, or mutilate batteries. Released electrolyte is harmful to the skin and eyes. It may be toxic.

Failure to follow these instructions will result in death or serious injury.

⚠ DANGER

HAZARD OF ELECTRIC SHOCK, EXPLOSION, OR ARC FLASH

Batteries can present a risk of electric shock and high short-circuit current. The following precautions must be observed when working on batteries

- Remove watches, rings, or other metal objects.
- Use tools with insulated handles.
- Wear protective glasses, gloves and boots.
- Do not lay tools or metal parts on top of batteries.
- Disconnect the charging source prior to connecting or disconnecting battery terminals.
- Determine if the battery is inadvertently grounded. If inadvertently grounded, remove source from ground. Contact with any part of a grounded battery can result in electric shock. The likelihood of such shock can be reduced if such grounds are removed during installation and maintenance (applicable to equipment and remote battery supplies not having a grounded supply circuit).

Failure to follow these instructions will result in death or serious injury.

⚠ DANGER

HAZARD OF ELECTRIC SHOCK, EXPLOSION, OR ARC FLASH



When replacing batteries, always replace with the same type and number of batteries or battery packs.

Failure to follow these instructions will result in death or serious injury.

Store the Batteries and the UPS System

NOTE: The battery modules must be stored indoors and with their protective packaging still in place.

NOTE: Stored batteries should be recharged at regular intervals, depending on the storage temperature.

		
Ambient temperature: -15 to 40 °C/ 5 to 104 °F	Relative Humidity: 0-95% Non-condensing	Storage place free from vibration, conductive dust, direct sunlight, and moisture.

Storage Temperature	Recharge Interval
-15 to 20 °C/ 5 to 68 °F	9 months
20 to 30 °C/ 68 to 86 °F	6 months
30 to 40 °C/ 86 to 104 °F	3 months

⚠ CAUTION

RISK OF EQUIPMENT DAMAGE

- Wait until the system is ready to be powered up before installing batteries in the system. The time duration from battery installation until the UPS system is powered up must not exceed 72 hours or 3 days.
- Batteries must not be stored more than six months due to the requirement of recharging. If the UPS system remains de-energized for a long period, we recommend that you energize the UPS system for a period of 24 hours at least once every month. This charges the batteries, thus avoiding irreversible damage.

Failure to follow these instructions can result in injury or equipment damage.

Battery Module

One battery module consists of four battery units (shipped in the cabinets).

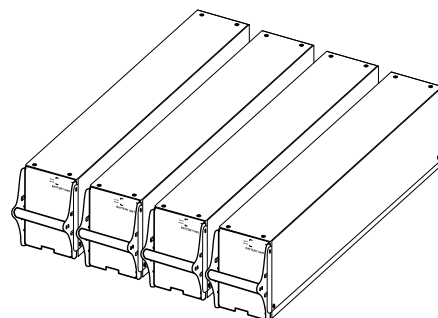

4 x 24 kg/4 x 53 lbs

Remove and Install Battery Locks

If your system is equipped with battery locks, follow the below procedure to remove the battery locks.

1. Remove the M6 screw attaching the battery lock to the shelf.

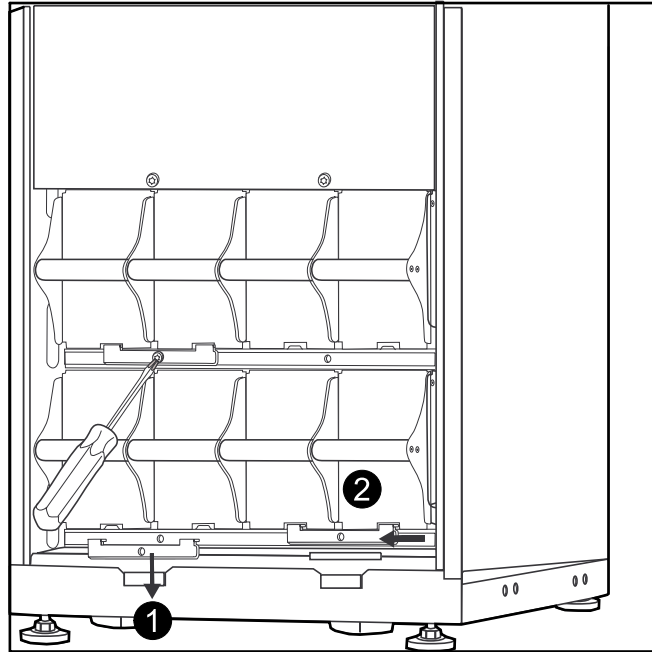

2. Push the battery lock to the left, push it upwards and remove.
3. Use the reverse procedure for the installation of battery locks.

Remove Battery for Replacement

Schneider Electric recommends that a whole battery module (four batteries) is replaced at the same time to ensure optimal runtime (see example 1). However, it is only necessary to replace two batteries at the same time according to Example 2 and 3 in the below tables.

523 mm (20 in) cabinet	Column A	Column B	Column C	Column D
Example 1	New	New	New	New
Example 2	New	New	Old	Old
Example 3	Old	Old	New	New

352 mm (14 in) cabinet	Column A	Column B
Example 1	New	New
	New	New
Example 2	New	New
	Old	Old
Example 3	Old	Old
	New	New

Follow the below procedures if you need to change or add a battery module, e.g. if you receive a display message reporting a bad battery, or if you need to add batteries for increased runtime.

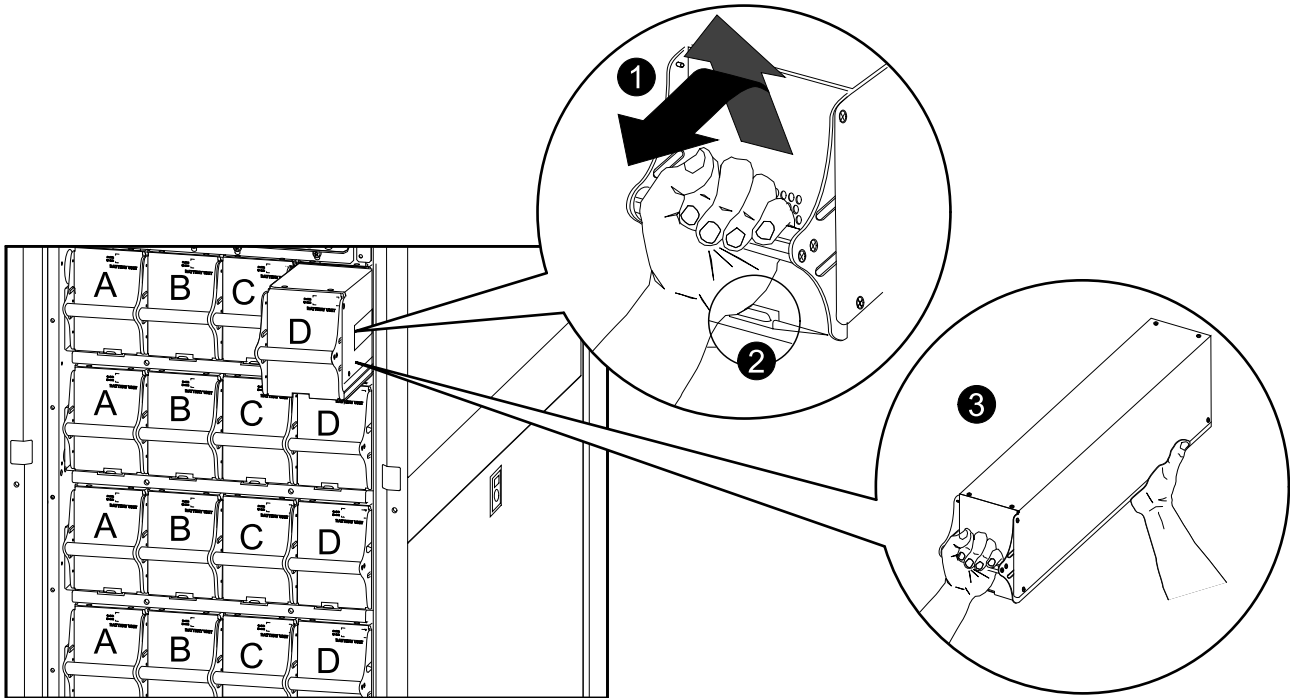

NOTE: When removing battery modules, start from the highest level and work down.

1. Holding the battery handle, gently push the battery upwards and pull it halfway out of the cabinet. A lock mechanism prevents it from being pulled all the way out.
2. Release the locking mechanism by lifting the modular battery unit.
3. Pull the modular battery unit completely out while supporting it.

Install Batteries

UPS/Modular Battery Cabinet

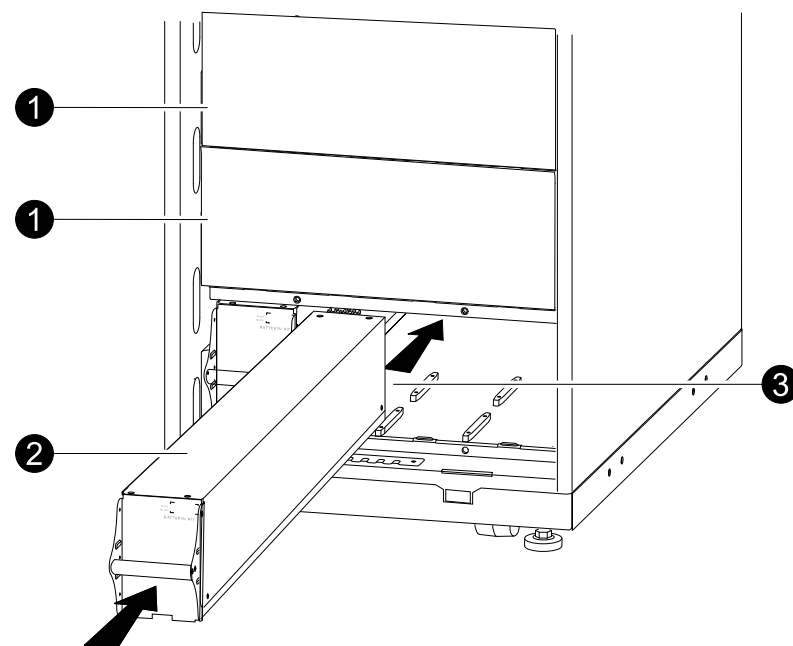

1. Remove the blind plate (if present) in front of empty battery shelves (if present) and save the screws for later use.
2. Install the battery module in the lowest available bay (four across in 523 mm (20 in) UPS versions, two across in 352 mm (14 in) UPS versions).

3. Position the battery unit to slide in between the grooves and push it completely into the UPS to ensure connection.

NOTE: If a problem is reported, ensure that the battery modules are correctly installed. If the problem persists, see the troubleshooting section.

NOTE: Allow for a 24-hour recharging period of the batteries after system start-up.

Troubleshooting

Status and Alarm Messages

This section lists the status and alarm messages that the UPS might display. The messages are listed in alphabetical order, and a suggested corrective action is listed with each alarm message to help you troubleshoot problems.

Display Messages

Display Message	Description	Corrective Action
Automatic Self Test Started.	The UPS has started the preprogrammed battery test.	No corrective action is necessary.
ABus Communication Fault.	Communication fault detected on the ABus.	Check ABus wiring. If this does not help contact Schneider Electric.
ABus Termination Fault.	ABus termination is missing.	Check if termination is present. If this does not help contact Schneider Electric.
Batt Temperature Exceeded Upper Limit.	The temperature of one or more battery units has exceeded the system specifications.	Contact Schneider Electric Customer Support
Battery over-voltage warning.	The battery voltage is too high and the charger has been deactivated.	Contact Schneider Electric Customer Support
Bypass Not Available Input Freq/Volt Out Of Range.	The frequency or voltage is out of acceptable range for bypass. This message occurs when the UPS is online, and indicates that the bypass mode may not be available if required.	Correct the input voltage to provide an acceptable voltage or frequency.
Battery Discharged.	The UPS is in battery operation and the battery charge is low. Note: Runtime is limited in duration.	No corrective action is necessary. Shut down the system and the load equipment or restore incoming voltage.
Emergency PSU Fault.	The redundant Emergency Power Supply Unit (PSU) is not working. The UPS will continue to work normally, but the PSU should be replaced.	Contact Schneider Electric Customer Support
EPO Activated.	The Emergency Power Off switch has been activated.	Deactivate the Emergency Power Off switch.
Fan fault.	A fan has failed.	Contact Schneider Electric Customer Support
Int. Mech. Bypass Switch Closed.	The internal mechanical switchgear is closed.	No corrective action necessary. The UPS is in internal mechanical bypass operation.
Int. Mech. Bypass Switch Open.	The internal mechanical switchgear is OFF.	No corrective action is necessary.
Low-Battery.	The UPS is in battery operation and the battery charge is low. Note: Runtime is limited in duration.	Shut down the system and the load equipment or restore incoming voltage.
Load Is No Longer Above Alarm Threshold.	The load previously exceeded the alarm threshold and the situation has been corrected either because the load decreased or the threshold was increased.	No corrective action is necessary.
Load Power Is Above Alarm Threshold.	The load has exceeded the user-specified load alarm threshold.	Option 1: Use the display interface to raise the alarm threshold. Option 2: Reduce the load.
Mains Not Available. Input Freq/Volt Out of Range.	The frequency or voltage is out of acceptable range for normal operation.	Correct the input voltage to provide acceptable voltage or frequency.
Minimum Runtime Restored.	The system runtime dropped below the configured minimum and has been restored. Additional Battery Modules were installed, the existing Battery Modules were recharged, the load was reduced, or the threshold was decreased.	No corrective action is necessary.

Display Message	Description	Corrective Action
No Batteries Are Connected.	No battery power is available.	Check that the batteries are inserted properly.
No Master is Present in the Parallel System.	No parallel master is present. The parallel system will not be able to function properly.	Contact Schneider Electric Customer Support
Number of Battery Modules Decreased.	One or more battery modules were removed.	No corrective action is necessary.
Number of Battery Modules Increased.	One or more battery modules were added.	No corrective action is necessary.
Overload on a Parallel Unit.	One or more systems has overload. Note that the entire parallel system will not be able to return from bypass.	No corrective action is necessary.
Order Startup Check.	The UPS system has been on for five days.	Contact Schneider Electric Customer Support to verify the installation.
Order Tech Check.	The UPS system has been on for four years. A technical check is recommended.	Contact Schneider Electric Customer Support.
PBus Communication Fault on Cable 1.	Communication fault detected on PBus 1.	Check PBus 1 wiring. If this does not help contact Schneider Electric.
PBus Communication Fault on Cable 2.	Communication fault detected on PBus 2.	Check PBus 2 wiring. If this does not help contact Schneider Electric.
PBus Termination Fault on Cable 1.	PBus 1 termination is missing.	Check if termination is present. If this does not help contact Schneider Electric.
PBus Termination Fault on Cable 2.	PBus 2 termination is missing.	Check if termination is present. If this does not help contact Schneider Electric.
Parallel Configuration Fault.	The parallel system has not been configured correct.	Contact Schneider Electric Customer Support.
Parallel Redundancy Restored.	The parallel redundancy has been restored.	No corrective action is necessary.
Parallel Redundancy is below Alarm Threshold	The load has exceeded the user specified load alarm threshold.	Option 1: Use the display interface to raise the alarm threshold Option 2: Reduce the load. Parallel redundancy is now restored.
Replace Batt(s).	One or more Battery Modules need replacement (only applicable with internal batteries).	See <i>Parts Replacement, page 23</i> for procedures.
Runtime Is Below Alarm Threshold.	The predicted runtime is lower than the user-specified minimum runtime alarm threshold. Either the battery capacity has decreased, or the load has increased.	Option 1: Allow the battery modules to recharge. Option 2: If possible, increase the number of battery modules. Option 3: Reduce the load. Option 4: Decrease the alarm threshold. Contact Schneider Electric Customer Support.
Shutdown Due To Low Battery.	The UPS was in Battery Operation and shut down the load when no more battery power was available.	No corrective action is necessary. Note: If the problem reoccurs, consider increasing the battery capacity.
Site Wiring Fault.	Wrong phase rotation on the input side. The UPS will continue to supply conditioned power from batt.	An electrician should check that the UPS has been wired properly.
Static Bypass Switch Fault.	The Static Bypass Switch has failed.	Contact Schneider Electric Customer Support.
System Failure Detected by Surveillance.	The system has detected an internal error.	Check for other alarms and contact Schneider Electric customer support if the problem persists.
System Start Up Configuration Failed.	System configuration error. Unable to determine system voltage and/or cabinet size.	Check for other alarms and contact Schneider Electric customer support if the problem persists.
System Not Synchronized to Bypass.	The system cannot synchronize to bypass. The mode may not be available.	Option 1: Decrease the input frequency sensitivity. Contact Schneider Electric Customer Support. Option 2: Correct the bypass input voltage to provide acceptable voltage or frequency.

Display Message	Description	Corrective Action
The dust filter must be changed immediately.	-	Replace the dust filter.
The dust filter must be changed soon.	-	Be prepared to change the dust filter soon.
UPS In Bypass Due To Fault.	The UPS has transferred to Bypass Mode because a fault has occurred.	Contact Schneider Electric Customer Support.
UPS In Bypass Due To Overload.	The load exceeded the power capacity. The UPS has switched to Bypass Mode.	Decrease the load.
UPS Is Overloaded.	The load exceeded the system power capacity.	Option 1: Decrease the load. Option 2: Check the load distribution on the 3 phases via the display. If the load is unevenly distributed, adjust the load distribution.
Warranty Expiring.	The warranty expires in three months.	Contact Schneider Electric Customer Support.
Weak Batt(s) Detected. Reduced Runtime.	One or more weak batteries detected.	Replace the weak batteries.
XR Battery Fuse Blown.	Modular battery fuse blown. Runtime is lower than expected.	Replace the blown fuse in the modular battery cabinet (only applicable if your installation includes a modular battery cabinet).

Schneider Electric
35 rue Joseph Monier
92500 Rueil Malmaison
France

+ 33 (0) 1 41 29 70 00

www.schneider-electric.com

As standards, specifications, and design change from time to time,
please ask for confirmation of the information given in this publication.

© 2006 – 2015 Schneider Electric. All rights reserved.

990–2819B–001