



imagination at work

GE Digital Camera

X Series : X500



User Manual

Getting Started

Basic operation

Camera function controls

Playback

Using the Menus

Camera connectivity

Appendix

WARNING

Do not expose the camera battery pack or other accessories to rain or humidity to prevent fire hazard or electric shock.

For customers in the U.S.A.

Tested To Comply With FCC Standards FOR HOME OR OFFICE USE

FCC Statement

This device complies with part 15 of the FCC Rules. Operation is subject to the following two conditions:

(1) This device may not cause harmful interference, and (2) this device must accept any interference received, including interference that may cause undesired operation.

For customers in Europe



"CE" mark indicates that this product complies with the European requirements for safety, health, environment and customer protection. "CE" marked cameras are intended for sales in Europe.



This symbol [crossed-out wheeled bin WEEE Annex IV] indicates separate collection of waste electrical and electronic equipment in the European countries. Please do not throw the equipment into the domestic refuse. Please use the return and collection systems available in your country for the disposal of this product.

Declaration of Conformity

Model Name: X500

Trade Name: GE

Responsible Party: General Imaging Co.

Address: 1411 W. 190th Street, Suite 550, Gardena,
CA 90248, U.S.A.

Customer Service Telephone Number: +1-800-730-6597

(Outside U.S. & Canada: +1-310-755-6857)

Conforms to the following Standards:

EMC: EN 55022:1998/A1:2000/A2:2003 Class B
EN 55024:1998/A1:2001/A2:2003
EN 61000-3-2:2000/A1:2001
EN 61000-3-3:1995/A1:2001

following the provision of the EMC Directive (89/336/
EEC,2004/108/EEC)

SAFETY PRECAUTIONS

Camera notes:

- ❗ Do not store or use the camera in the following types of locations:
 - In the rain, very humid and dusty places.
 - In a place where the camera can be exposed directly to the sunlight or subject to high temperature, e.g. Inside a closed car in summer.
 - In a place where the camera is subject to a high magnetic field, e.g. near motors, transformers or magnets.
- ❗ Do not place the camera on a wet surface or places where dripping water or sand may come in contact with the camera, which may cause irreparable faults.
- ❗ If the camera will not be used for a long period of time, we suggest you remove the battery and the memory card from the camera and keep them in dry environment.
- ❗ If you carry the camera suddenly from a cold location to a warm place, moisture may condense inside the camera. We suggest you wait for a while before turning on the camera.
- ❗ If water has gotten inside the camera, turn off the camera and remove the battery and memory card. Allow to air-dry for at least 24 hours before using the camera again.
- ❗ If camera overheats, while in use or charging, disconnect charger and carefully remove batteries

Battery notes:

- ❗ Incorrect use of the batteries may cause them to leak, become hot, ignite or burst. Always observe the precautions given below.
 - Do not expose the batteries to water, and take particular care to keep the terminals dry.

- Do not heat the batteries or throw them into a fire.
- Do not attempt to deform, disassemble or modify the batteries.

- ❗ Keep the batteries out of reach of babies and small children. In cold locations, battery performance deteriorates and the time for which they can be used shortens markedly.

Memory card notes:

- ❗ When using a new memory card, or a memory card that has been used or initialized by a P.C. or a different model camera, be sure to format the card with your digital camera before using it.
- ❗ To edit image data, copy the image data to the PC's hard disk first.
- ❗ Do not change or delete the folder names or file names in the memory card from your PC, as this may cause a memory card read error to occur when viewing photos on the memory card from the playback mode in your camera.
- ❗ The photos taken by this camera are stored in the auto-generated folder in the SD card. Please do not store photos that are not taken by this model of camera, as this may cause a read error to occur when the camera is in playback mode.
- ❗ Please do not expose the camera to harsh environments such as moisture or extreme temperatures, which may shorten the life of your camera or damage the batteries.
- ❗ Do not remove memory card without turning the digital camera off to avoid possible damage of your memory card.
- ❗ Do not switch off the digital camera when a writing process is occurring to avoid incomplete data writing and damaged pictures.
- ❗ Align the memory card correctly before inserting it into the camera's SD card slot. Do not force the memory card into the camera's SD card slot.

BEFORE YOU START

Preface

Thank you for purchasing this GE digital camera. Please read this manual carefully and keep it in a safe place for future reference.

Copyright

© Copyright 2011 General Imaging Company All rights reserved.

No part of this publication may be reproduced, transmitted, transcribed, stored in a retrieval system, or translated into any language or computer language, in any form, by any means, without the prior written permission of General Imaging Company.

Trademarks

All trademarks mentioned in this manual are used for identification purposes only and are properties of their respective owners.

Safety information

Please read the following important information carefully before using the product.

- Do not take apart or attempt to service the camera yourself.
- Do not drop or knock the camera. Improper handling may damage the product.
- Turn off the camera before inserting or removing the battery and memory card.
- Do not touch the camera lens.
- Please do not expose the camera to harsh environments such as moisture, chemicals or extreme temperatures, which may shorten the life of your camera or damage the batteries.
- Do not use or store the camera in dusty, dirty, or sandy areas, as its components may be damaged.

- Do not expose the lens to direct sunlight for extended periods.
- Download all pictures and remove the batteries from the camera if you are going to store the camera for long periods of time.
- Do not use abrasive cleansers, alcohol-based, or solvent-based cleaners to clean the camera. To clean, wipe the camera with a slightly damp soft cloth.
- If water has gotten inside the camera, turn off the camera and remove the battery and memory card. Allow to air-dry for at least 24 hours before using the camera again.
- Do not touch lens.
- Do not place camera strap around a child's neck
- Always carry camera in a padded camera bag.
- When coming in from a cold to a warm environment, avoid condensation by placing camera in a cooler area and then let it warm up slowly to room temperature.
- Always place the camera on a vibration-free surface.

About this manual

This manual provides you with instructions on how to use your GE digital camera. Every effort has been made to ensure that the contents of this manual are accurate, however General Imaging Company reserves the right to make changes without notice.

Symbols used in this manual

Throughout this manual, the following symbols are used to help you locate information quickly and easily:



Indicates useful information to know.



Indicates precautions to be taken while operating the camera.

CONTENTS

WARNING	i	Set Display Language	14
SAFETY PRECAUTIONS	ii	Set Date/Time.....	15
BEFORE YOU START	1	Using the Mode Dial.....	16
Preface	1	About the LCD Screen.....	17
Copyright	1	Electronic Viewfinder.....	18
Trademarks	1	BASIC OPERATION	19
Safety information	1	Shooting in Auto Mode.....	19
About this manual	2	Using the Zoom Function.....	19
Symbols used in this manual	2	Open Flash	20
CONTENTS	3	Self-timer.....	21
GETTING READY	7	Macro Mode.....	22
Unpacking.....	7	EV (Exposure Value)	22
Install Shoulder Strap and Lens Cap.....	8	Face Detection	23
Camera Views	9	Smile Detection	24
Inserting the Battery and		Blink Detection.....	24
SD/SDHC Card (Not included)	12	Stabilization.....	25
Turning On and Off	14	Advanced Functions Menu	26
Setting Language and Date/Time.....	14	WB (White Balance)	27
		ISO	27

Quality	28	Indoor	37
Size	28	Snow	37
Color	29	Fireworks	37
USING THE MODES	30	Museum	37
LCD Screen Display	30	Night Landscape	37
Still Picture Mode Display	30	Children	37
Video Shooting Mode Display	32	Leaf	38
Playback Mode Display	33	Sunset	38
Auto Scene Mode (ASCN)	34	Glass	38
Landscape	34	Landscape	38
Portrait	34	Night Portrait.....	38
Night Portrait	35	Beach.....	38
Backlit Portrait	35	Text.....	38
Night Landscape	35	Gathering.....	38
Macro	35	ID	38
Auto	35	Fish eye	38
Panorama	35	Travel shooting.....	38
Scene Mode (SCN)	36	Photo frame	38
Sport	37	Sketch.....	38
		Portrait Mode	39

Auto Program Exposure	39	Digital Zoom	51
Shutter Priority	40	Movie Menu	52
Aperture Priority	41	Continuous AF	53
Manual Mode.....	41	Expo Metering (Exposure Metering)	53
PLAYBACK	42	Playback Menu	54
Viewing Photos and Videos	42	Protect	54
Thumbnail View	43	Delete	55
Using Zoom on Playback (for still pictures only)	44	DPOF (Digital Print Order Format)	56
Using the Delete Button	45	Trim	57
USING THE MENUS	46	HDR-High Dynamic Range.....	57
Still Picture Menu	46	Resize	58
AF Mode (Auto-Focus mode)	47	Rotate	58
AF-assist Beam	47	Red-eye Reduction.....	59
Continuous AF	48	Display Setup.....	59
Expo Metering (Exposure Metering)	48	Slideshow	60
Continuous Shot	49	Wallpaper Settings	60
Date Imprint	50	Setup Menu	63
Quick Review	50	Beep	64

LCD Brightness	64	Using the PictBridge Menu	74
Power Saver	65	Print with Date	74
Zone	65	Print without Date	75
Date/Time	66	Print Index	76
Language	66	Print DPOF	77
File and Software	66	Exit	77
File Numbering	67	APPENDICES	78
Copy to Card (Copy internal memory to memory card)	67	Specifications	78
Reset Settings	68	Error Messages	82
FW Version (Firmware version)	68	Troubleshooting	84
CONNECTIONS	69		
Video System	69		
Connecting to a PC	70		
Setting the USB Mode	70		
Transferring Files to your PC	70		
Connecting to a PictBridge Compatible Printer	72		
Setting the USB Mode	72		
Connecting the Camera and Printer	73		

GETTING READY

Unpacking

Your package should contain the camera model you purchased along with the following items. If anything is missing or appears to be damaged, please contact your vendor.

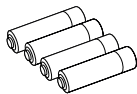

AA-size Alkaline Batteries



Warranty Card

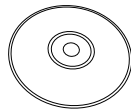

CD-ROM

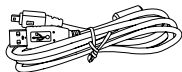

USB Cable

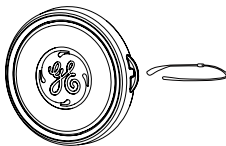

Lens Cap



Shoulder Strap

Install Shoulder Strap and Lens Cap

Install Shoulder Strap

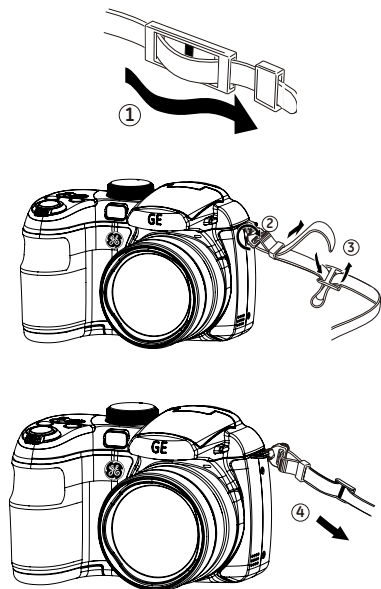

Install Lens Cap

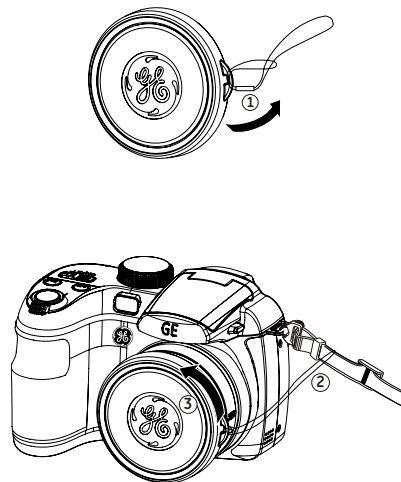

Left View

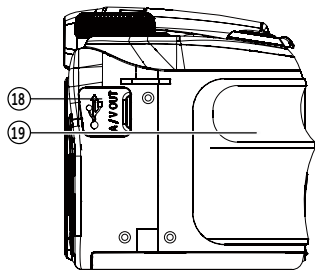

Right View

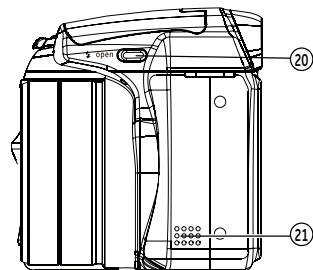

Top View

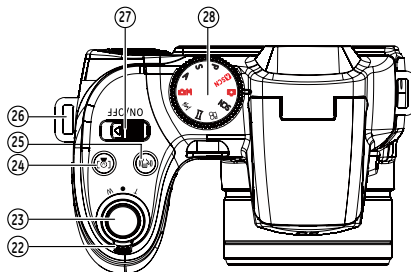

Bottom View

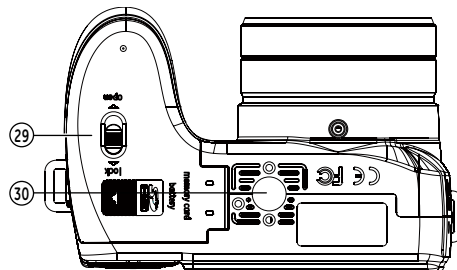

1	AF Assist/Timer Indicator	11	Exposure Compensation Button	21	Speaker
2	Flash Lamp	12	Menu Button	22	Zoom Wheel
3	Microphone	13	Delete Button/Up Button	23	Shutter Button
4	Lens	14	Macro Button/Right Button	24	Face Identification Button
5	LCD Screen	15	Self-timer Button/Down Button	25	Stabilization Button
6	Electronic Viewfinder	16	Flash Button/Left Button	26	Shoulder Strap Mount
7	Status Indicator	17	OK Button	27	ON / OFF
8	Electronic Viewfinding Window/ LCD Screen Button	18	USB/AV Port	28	Mode Dial
9	Playback Button	19	Handle	29	Card Slot/Battery Compartment
10	DISP	20	Flash On Button	30	Tripod Socket

Insert the Battery and SD/SDHC Card (Not included)

1. Open the battery compartment.

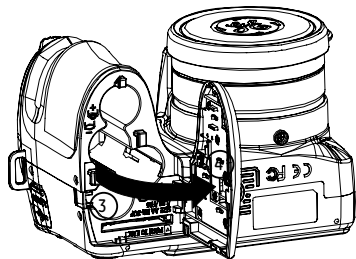
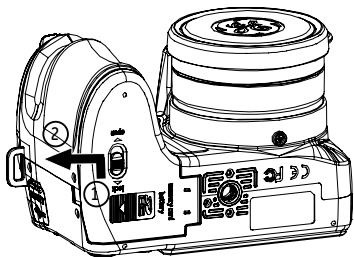

2. Insert the enclosed batteries into the battery slot according to the correct polarity as shown below.

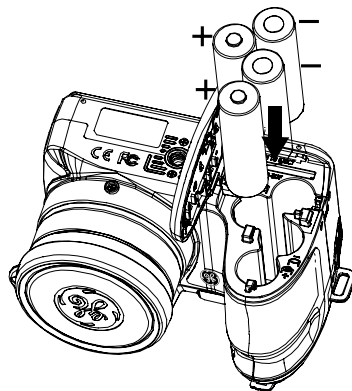

3. Insert an SD/SDHC card (not included) into the memory card slot as shown.

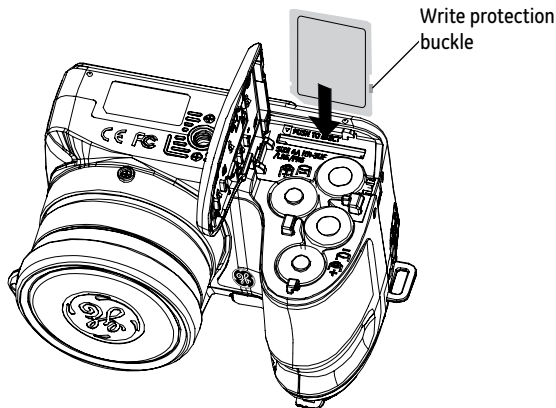

4. Close the battery compartment.

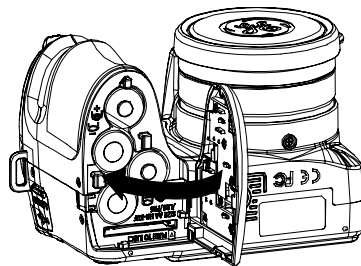

Optional SD/SDHC cards are not included. The use of 64MB to 16 GB memory cards from recognized manufacturers such as SanDisk, Panasonic and Toshiba is recommended for reliable data storage.

To remove the SD/SDHC card, open the battery compartment and gently push the card to release it. Pull the card out carefully.

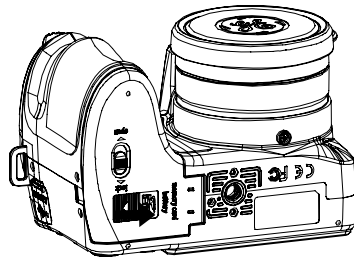

Turning On and Off

Push ON/OFF to turn on/off camera.

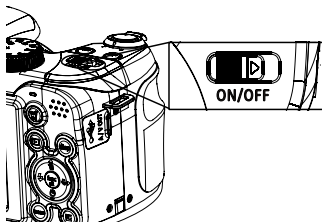



After the camera is powered on, set the camera to Auto mode by turning the Mode dial at the top of the top of the camera (see page 16). When using the camera for the first-time, the language setting page will appear.

Setting Language and Date/Time

When turning on the camera for the first time, the Display Language and Date/Time Setup menu will appear. Use the following procedures to set the camera to your preferences:

1. Push ON/OFF to turn on the camera.
2. Press Up/Down/Left/Right button to select the settings.
3. Press the  button to confirm the settings.

Set Display Language

1. Press the  button and the Left/Right button and select the General Setup menu tab.
2. Use the **Up/Down** button and scroll down to **Language**. Then press the **Right** button to access the language options.
3. Use the Up/Down/Left/Right buttons to select the desired language.
4. Press the  button to confirm the setting.



Set Date/Time







1. Press the **menu** button and use the Up/Down button to select the the General Setup menu tab. Press the **find ok** button to enter the Date/Time menu.

2. Use the Left/Right button to select date or time field, then press Up/Down buttons to adjust values.
3. Press the **find ok** button to confirm the settings.



Using the Mode Dial

The GE camera provides a convenient mode dial that allows you to switch between different modes with ease. All the available modes are listed as follows:

Mode Name	Icon	Description
Auto mode		Take still pictures in automatic mode.
ASCN mode		Have the camera automatically select the best scene type for still pictures.
Program AE	P	This setting allows you to choose the EV value and the camera will select both the shutter speed and aperture automatically.
Shutter priority	S	This setting allows you to choose a specific shutter speed while the camera will adjust the aperture automatically to ensure correct exposure.
Aperture priority	A	This allows you to choose a specific aperture and the camera will automatically the adjust the shutter speed to match it.
Manual mode		Many of the camera settings can be configured manually in this mode.
Portrait		Take portrait pictures under normal conditions.
Panorama mode		Capture a sequence of shots and stitch them together into a panoramic photo.
Movie mode		Record videos.
Scene mode	SCN	Choose from 20 different scene types and effects for your photos.

About the LCD Screen

When you turn the camera on, various icons are shown on the LCD screen to indicate the current camera settings and status. To learn more about the displayed icons, see “LCD Screen display” on page 30.

LCD Screen notes:

Extremely high-precision technology has been used to manufacture the LCD screen so that most of the pixels are operational for use. However, there may be some minute points (black, white, red, blue or green) that constantly appear on the LCD screen. These points are normal in the manufacturing process and the recording is not affected in any way.



Avoid exposing the LCD screen to water; please remove any moisture on the LCD screen with a soft, dry cleaning cloth.



If the LCD monitor is damaged, take particular care with the liquid crystal in the monitor. If any of the following situations arise, take the recommended immediate action indicated below:

- If liquid crystal comes in contact with your skin, wipe the area with a cloth and then wash thoroughly with soap and running water.
- If liquid crystal gets into your eye, flush the affected eye with clean water for at least 15 minutes and then seek medical assistance.
- If the liquid crystal display or the liquid inside it are swallowed, flush your mouth thoroughly with water. Drink large quantities of water and induce vomiting. Then seek medical assistance immediately.

BASIC OPERATION

Shooting in Auto Mode

Auto mode is the easiest mode to take photos. While operating in this mode, the camera automatically optimizes your photos for best results.

To start shooting, do the following:

1. Push ON/OFF to turn on the camera.
2. Switch the Mode dial to **Auto** mode ().
3. Compose your picture on the LCD screen and press the Shutter button halfway to focus on the subject.
4. The LCD screen will show a green focus frame after the subject is in focus.
5. Press the **Shutter button** fully to capture the image.

Using the Zoom Function

Your camera is equipped with two types of zoom functions: optical zoom and digital zoom. Press the Zoom button of the camera to zoom in or out of the subject while taking pictures.

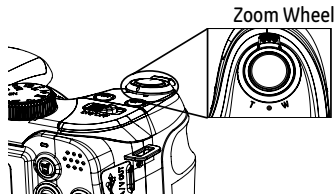

Zoom indicator (See "Digital Zoom" on page 51)

When the optical zoom reaches its maximum value, release the Zoom button and then press it again for the digital zoom to begin. The zoom indicator is hidden after the Zoom button is released. The screen shows () for the current zoom status.

Open Flash

The flash is used to illuminate a subject in low light or for fill-in lighting to achieve better illumination of a subject with pronounced shadows.



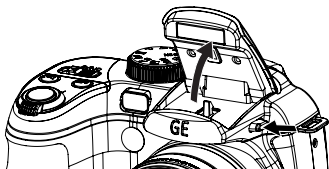

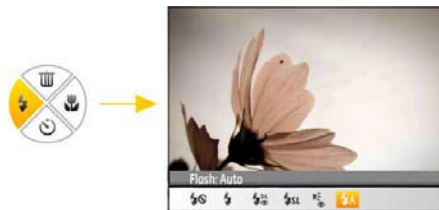

1. To turn on the flash, press the flash  button.



2. Press the left button to enter the flash Functions menu.



3. Press the Left/Right button to select from the following 6 modes:

-  **Flash: Auto**
Camera flash goes off automatically based on existing light conditions.
-  **Flash: Red-eye reduction**
The camera emits a brief flash before the picture is taken to reduce red-eye effects.
-  **Flash: Forced flash**
Make forced flash at the moment of shooting.
-  **Flash: Forced off**
Flash is turned off.
-  **Flash: Slow Synchro**
This allows for night scenery photos that include people in the foreground. The use of a tripod is recommended when shooting with this setting.
-  **Flash:Red-Eye+Slow Synchro**
Using this mode for slow synchro shots with red-eye reduction.

4. Press the  button to confirm the settings and exit the option.

Self-timer

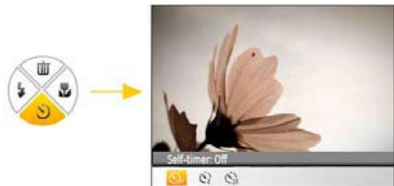

This setting allows the photographer to set the camera for self portraits or group shots. The timer can be set to fire the shutter 2 seconds, or 10 seconds after the shutter button is pressed.

1. Press the Down button to enter the Self-timer menu.



2. Press the Left/Right button to select the following three modes:

-  Self-timer: 2 sec
A single picture is shot 2 seconds after the Shutter button is pressed.

-  Self-timer: 10 sec
A single picture is shot 10 seconds after the Shutter button is pressed.
 -  Self-timer: Off
Disables the self-timer.
3. Press the  button to confirm the settings and exit the menu.



Macro Mode

The Macro setting is ideal for shooting small objects or close-up photos. This mode allows you to focus on subjects very close to the camera.

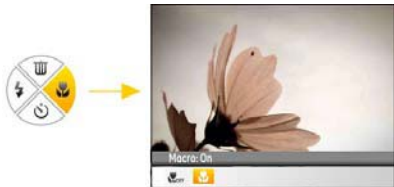
1. Press Right button to enter the Macro menu.



2. Press the Left/Right button to select the following two modes:

-  Macro: On
Select this to focus on subjects 5cm from the lens.
-  Macro: Off
Select this option to disable Macro.

3. Press the  button to confirm the settings and exit the menu.

EV (Exposure Value)

The EV control allows for an override of the camera's auto exposure settings in order to provide more control in tricky lighting conditions. This will allow you to lighten or darken the exposure to your preference.

1. Press the  button to enter the exposure settings screen.



2. Press the Up/Down button to adjust the exposure value of the image, from the range between EV -2.0 to EV+2.0.

Face Detection

The face detection mode detects people's faces and focuses on them resulting in clearer images. Face detection is engaged by default in most modes unless it is disabled by the user. Face detection is disabled in Panorama Mode.

1. When the face detection feature is enabled it will display a frame around detected faces in the camera's field of view.
2. Press the Shutter halfway to focus on the subject.
3. Press the Shutter fully to capture the image.
4. Press the Face Detection button to close this function.

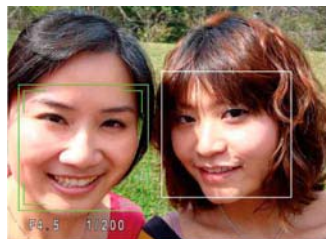
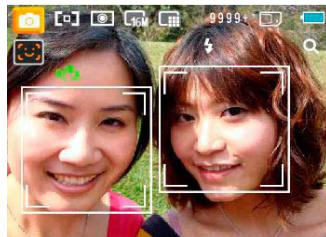

Smile Detection

The Smile Detection feature automatically detects and captures a person's smile.

1. In shooting mode, Press the Face Detection button until the icon  appears on the LCD screen
2. Point the camera at the subject, and press the Shutter button half way to focus.
3. Press the Shutter button all the way to capture the image, the camera will automatically release the shutter when it detects a smile.

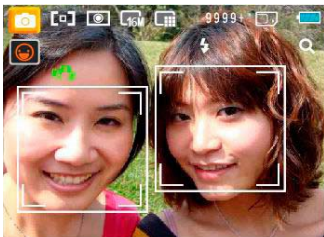

4. Press the Face Detection button to close this function.

Blink Detection

Blink Detection is enabled by default unless disabled by the user. When shooting, if a face is detected with its eyes closed, the Blink Detection  will appear on the screen to show that a blink was detected.

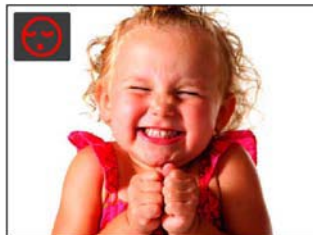

Stabilization

While in Shooting mode, press the  button to reduce blurred images caused by hand shake. The LCD will display either the Continuous or Single stabilization icon.



Advanced Functions Menu

The Advanced Functions Menu of the camera include Image Size, Image Quality, White Balance, Image Color and ISO. These functions allow advanced users better control for shooting under difficult lighting conditions.

To set the Advanced Functions:

1. Pull up the Advanced Function Menus by pressing  button.



2. Press Down button to enter the advanced function selection screen, press Left/Right button to select the function that you want to set.
3. Press Up button to enter the advanced function setting interface.









4. Use the Left/Right buttons to change the settings and then press  to confirm the new settings and close this Advanced Function Menu.

WB (White Balance)

The White Balance allows you to adjust the color temperature for different lighting sources to ensure faithful color reproduction.



The options for White Balance include:

-  WB: Auto
-  WB: Daylight
-  WB: Cloudy
-  WB: Fluorescent
-  WB: Fluorescent CWF
-  WB: Incandescent
-  WB: Manual (Press the Shutter button to detect WB)

ISO

The ISO function allows you to set the sensitivity of the camera's sensor based on the brightness of the scene. To improve the camera's sensor performance in darker environments, a higher ISO value is required. On the other hand, a lower ISO value is needed when in bright conditions.

Pictures at higher ISO will naturally have more noise than those at lower ISO.



The camera's ISO settings include automatic, 80, 100, 200, 400, 800, 1600 and 3200.



The available ISO values vary on different camera models.

Quality

The camera's quality setting adjusts the compression ratio of the images. Higher quality settings produce better quality photos, but will take up more memory space.



Size

The size setting refers to the image resolution in pixels. A higher image resolution allows you to print that image in larger sizes without degrading the image quality.



There are three options for picture quality:

-  : Quality: Best
-  : Quality: Fine
-  : Quality: Normal



The bigger the number of recorded pixels is, the better the image quality becomes. As the number of recorded pixels becomes smaller, you will be able to record more images on a memory card.

Color

The color setting allows you to add artistic color effects when taking pictures. You can try different color tones to alter the mood of your pictures.



The color options include:

-  Color: Auto
-  Color: Vivid
-  Color: Black & White
-  Color: Sepia

USING THE MODES

LCD Screen Display

Still Picture Mode Display

Mode: **ASCN P S A M** **SCN**

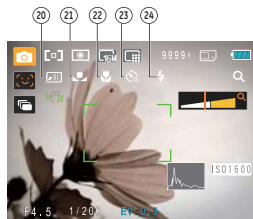
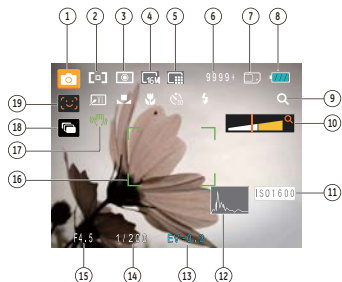

1 Shooting Mode Icons



Auto mode



ASCN mode



Scene mode



Program AE



Aperture priority



Manual mode



Panorama mode



Portrait



Shutter priority

2 AF Mode



Single-AF



Multi-AF

3 Expo Metering



Spot





Center



AiAE

4 Image Size

5 Image Quality

- 6 Remaining number of pictures
- 7 Memory card/built-in memory
- 8 Battery Status
- 9 WT Ratio (Displayed only when zoom is activated)
- 10 Zoom
- 11 ISO Value (Adjustable only in  M P S A Manual Mode)
- 12 Histogram
- 13 Exposure compensation
- 14 Shutter speed
- 15 Aperture value
- 16 Focus Frame
- 17 Stabilization
- 18 Continuous Shot
- 19 Face Detection
- 20 Picture Color
(Adjustable only in  M P S A Manual Mode)
- 21 White Balance
(Adjustable only in  M P S A Manual Mode)
- 22 Macro Mode

23 Self-timer

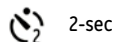

2-sec

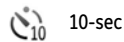

10-sec

24 Flash Mode



Flash: Auto



Flash: Red-eye reduction



Flash: Forced flash



Flash: Forced off



Flash: Slow Synchro



Flash: Red-Eye+Slow Synchro

Video Shooting Mode Display

Mode : 

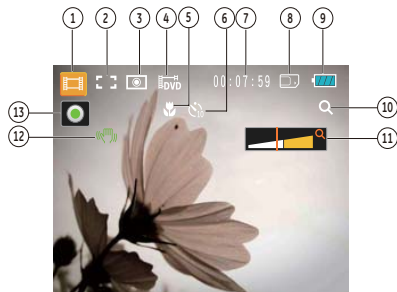

- 1 Video Mode icon
- 2 Continuous AF
- 3 Metering



Spot



Center



AiAE

- 4 Video Quality
- 5 Focus Frame
- 6 Self-timer



10-sec

- 7 Remaining Time for Video Recording
- 8 Memory Card/Built-in Memory
- 9 Battery Status
- 10 WT Ratio (Displayed only when zoom is activated)
- 11 Zoom
- 12 Stabilization
- 13 Recording Status Icon



Recording standby



Recording



For optimal video shooting, it is recommended that an SD card be used. If you try to shoot video with just internal memory the results may show picture jitter, noise and a short recording.



During the shooting, both optical zoom and up to 6x digital zoom are available.

Playback mode display



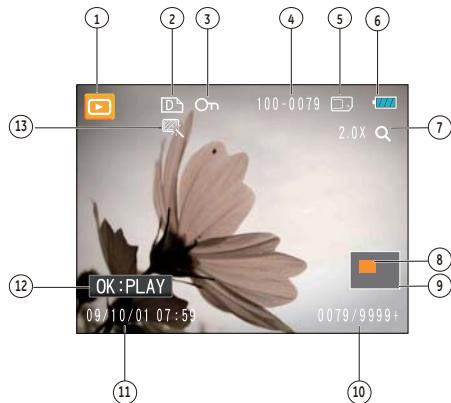



Mode: 



- 1 Play Mode icon
- 2 DPOF file
- 3 File protection
- 4 Picture Number
- 5 Memory Card/Built-in Memory
- 6 Battery Status
- 7 Image Zoom
- 8 The current display area
- 9 Affecting regional
- 10 Memory Space (this picture/Total number of pictures)
- 11 Recording Date and Time
- 12 OK:PLAY
- 13 HDR

Auto Scene Mode (ASCN)

In the "ASCN" mode, different recording conditions are detected intelligently and the most suitable settings will be automatically selected.

Icon	Mode name	Icon	Mode name
	Landscape Mode		Night Landscape Mode
	Portrait Mode		Macro Mode
	Night Portrait		Auto Mode
	Backlit Portrait		

To use "ASCN":

1. Turn the mode dial to "ASCN", The LCD screen will display the following icons.



2. Hold the camera steadily and aim at the subject. The optimum scene mode will be identified automatically.
3. Press the Shutter button halfway down to focus.
4. Press the Shutter button all the way down to take the picture.

Landscape Mode

For landscapes, ASCN will automatically adjust the exposure to match the background.

Portrait Mode

For portraits, ASCN will automatically adjust the exposure and skin tones to give clear pictures.

Night Portrait

When you taken portraits at night, or in low light conditions, ASCN will automatically adjust the exposure for people and night scenes.

Backlit Portrait

When the sun or any other light source is behind you, ASCN will automatically adjust the foreground exposure to produce good pictures.

Night Landscape Mode

For night scenes, ASCN will automatically increase the ISO value to compensate for low light.

Macro Mode

To produce more detailed close-ups, ASCN will automatically engage the lens Macro mode and automatically focus the lens.

Auto Mode

The camera will automatically adjusts the exposure and focus to ensure good pictures.

Panorama

Panorama Mode allows you to create a panoramic picture. The camera will automatically compose a panoramic picture using the individual shots that you take.

Follow these steps to create a panoramic picture:

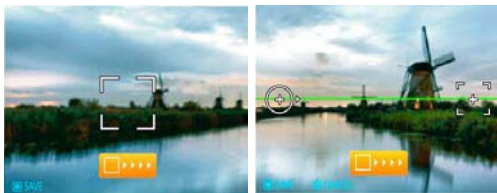

1. Turn the mode dial to the Panorama Mode.
2. Use the Left/Right buttons to specify the direction of the photo sequence. If nothing is chosen, in 2 seconds the panoramic sequence will commence at the default direction of left to right.
3. Compose the first view of the panoramic picture on the LCD screen and press the Shutter button to capture the photo.
4. After the first shot is taken, two target icons will appear on the left and right side of the LCD screen. Pan the camera and the circle icon on the screen will move towards the square frame icon. When the circle icon and square frame overlap and turn green, the camera will capture the image automatically. Repeat this step for the third picture in the series.



Manual Scene Mode (SCN)





















In **Manual Scene** mode, you can select from a total of 20 scene types to match your needs. The camera will automatically adjust to the optimal settings based on the scene type that is chosen.

To enter the Scene Mode, turn the mode dial to **Manual Scene** mode. The Scene Mode palette will appear.

-  Flash Mode, Self-timer, Macro Mode, and Exposure Compensation are disabled in Panorama Mode.
-  Pictures cannot be deleted, and the zoom will be disabled until the series is finalized.
-  Panorama Mode can stitch 2 or 3 pictures maximum.



Select a scene using the Up/Down/Left/Right button and press the  button.

Icon	Mode Name	Icon	Mode Name
	Sport		Indoor
	Snow		Fireworks
	Museum		Night Landscape
	Children		Leaf
	Sunset		Glass
	Landscape		Night Portrait
	Beach		Text
	Gathering		ID
	Fish eye		Travel shooting
	Photo frame		Sketch

Sport

For fast-moving subjects. Capture sharp action shots with minimal blur.

Indoor

For indoors. Reduce blur and improve color accuracy.

Snow

For snow scenes. Reproduce natural and clear white scenes.

Fireworks

For fireworks at night. Slow shutter speed adjusted for brilliant images. The use of a tripod is recommended.

Museum

For museum or flash-free area. Retain color and reduce blur.

Night Landscape

For night scenes. The use of tripod is recommended.

Children

For kids and pets. Flash is disabled for eye protection.

Leaf

For plants. Capture brilliant shots of greenery and blossoms.

Sunset

For sunsets. Capture subjects in strong sunlight.

Glass

For objects behind transparent glass.

Landscape

For landscapes. Vivid reproduction of green and blue.

Night Portrait

For portraits against night scenery.

Beach

For taking pictures in areas with strong sunlight.

Text

For taking pictures of text or documents or white boards.

Gathering

For taking pictures of large groups or in areas with uneven lighting.

ID

For shooting ID size photos.

Fish eye

Creates a fish-eye effect, by distorting the center of the image.

Travel shooting

Produces background image blur that emphasizes the motion of the main subject.

Photo frame

For adding interesting frame effects to the photo.

Sketch

For taking photos with pencil sketch effect.

Portrait Mode

In Portrait Mode, the camera is set to automatically adjust exposure for realistic capture of skin tones.

1. Turn the mode dial to select Portrait Mode ()
2. Once in this mode, you can use other functions, such as image stabilization, face detection and smile detection.

Auto Program Exposure P

When selecting P (Auto Program Exposure) mode, you can adjust the combined value of EV value, shutter speed and aperture. The display on the LCD screen is as shown in the figure below:



1. Set the mode dial at the top of the camera to P and press the  button to enter the Auto Program Exposure settings menu.
2. Press the Left/Right button to select the combination of EV, shutter speed and aperture for your scene.



3. Press Up/Down button to take the parameter adjustment.
4. Press the  button to engage the settings and enter the shooting screen.

 Shutter speed is adjustable between 30 and 1/2000;
aperture size is adjustable between 3.0 and 7.9;
EV value is adjustable between +2.0 and 2.0.

 When you press the shutter half way, the aperture size and shutter value of the current detection will display in the lower, left corner of the screen.

Shutter Priority S

When selecting S (Shutter Priority) mode, you can adjust the shutter speed and EV value. Selecting a high shutter speed will capture fast moving objects clearly. Selecting a slow shutter speed will result in motion blur of moving objects.

1. Set the mode dial to S and press the  button to enter the Shutter Priority settings menu.
2. Press the Left/Right button to select EV/shutter speed.



3. Press the Up/Down button to set the parameter adjustment.
4. Press the  button to confirm the settings and enter the shooting screen.

Aperture Priority A

When selecting A (Aperture Priority) mode, you can adjust the aperture size and EV value. Selecting a large aperture opening will emphasize the point of focus, and show a blurry background and foreground. A small aperture opening will keep both the background and main object in clear focus.

1. Set the mode dial to A and press the  button to enter the Aperture Priority setting's menu.
2. Press the Left/Right button to select EV/aperture.



3. Press the Up/Down button to take the parameter adjustment.
4. Press the  button to confirm the settings and enter the shooting screen.

Manual Mode

When selecting M (manual) mode, you can set the aperture and shutter speed manually.

1. Set the mode dial to M and press the  button to enter the Manual Mode setting's menu.
2. Press the Left/Right button to select the aperture/shutter speed.





3. Press the Up/Down button to select the parameter adjustment.
4. Press the  button to confirm the settings and enter the shooting screen.

PLAYBACK

Viewing Photos and Videos

To view the captured photos and video clips on the LCD screen:

1. After pressing the  button, the last photo or video clip taken will display on the LCD screen.
2. Use the **Left/Right** navigation buttons to scroll through the photos or video clips stored in the internal memory or memory card.
3. To play a selected video clip, press the  button to enter the movie playback mode.

During video playback, the operating instructions will appear on the screen. Press the **Left/Right** button, and press the  button for confirmation.

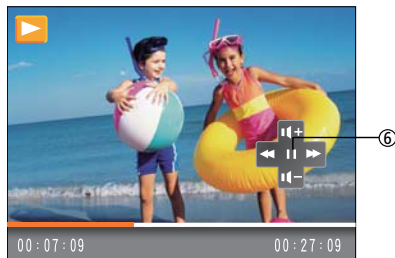
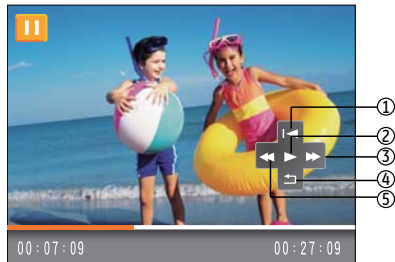

The operating instruction icons are as follows.

- | | | | |
|---|------------------------------------|---|---------------------------|
| 1 | Return to the first frame and play | 4 | Return to the first frame |
| 2 | Play | 5 | Rewind |
| 3 | Fast Forward | 6 | Pause |

When playing movie, press Up/Down arrow button mute the volume, press the down arrow until the mute  appears.

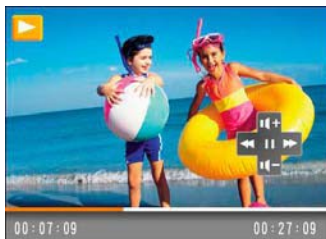

Thumbnail View

When in **Playback** mode, press one end of the Zoom button (**W**) to display the thumbnail of photos and videos on the screen.

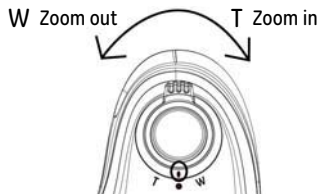

1. Use the Zoom button to switch between the 3x3, and 4x4 and Date Folder thumbnail display.



2. When displaying 3x3 and 4x4, use Up/Down/Left/Right button to select a picture or video clip for view; when displaying the Date Folder, use Up/Down button to select the Date Folder.
3. When displaying the Date Folder, pressing  button can enter date information index.



- Use Up/Down/Left/Right button to select a picture or video clip, press the  button to return to the original size.



The Date Folder is displayed in order based on the shooting date.





If the  indicator appears on the LCD, then a movie file is currently being displayed.



Press the  button to restore a preview icon to its original image size.

Using Zoom Playback (for still pictures only)

The zoom buttons can also be used during playback. This allows you to magnify photos between 2x to 8x.

- Press the  button to switch to playback mode.
- Use the **Left/Right** navigation buttons to select a photo to magnify.
- Press one end of the Zoom button () to zoom in.
- Use the Zoom buttons to zoom in and out. The zoom indication and the frame of the whole photo will display on the screen.



- Use the navigation buttons to pan across the image.
- Press the  button to return the image to its original scale.





Movie images cannot be magnified.

Using the Delete Button

In Playback Mode, you can press the Up/Delete button to delete an unwanted photo or video.

To delete pictures or videos:

1. Press the  button to switch to playback mode.
2. Select a picture or video clip you want to delete with the Left/Right button.
3. After pressing the Up/Delete button, the delete screen will display on the screen.
4. Select Yes or Back with the Up/Down button and press the  button for confirmation.



Erased photos/video clips cannot be recovered.



Please refer to page 55 for instructions on the Delete Menu options.



USING THE MENUS

Photo Menu

Mode:        

In any of the above Photo Modes, press the  button to go to the Photo Menu.



To adjust each setting:

1. In the Photo Menu, use the Left/Right button to select the Tab (at the top of the screen) corresponding to the page containing the function you wish to change.



2. Press the Up/Down buttons to select the function.
3. Press the Right button, or the function  button to go to the sub-menu.



4. In the sub-menu press the Up/Down button to select a setting and press the function  button to confirm that setting and exit the sub-menu.  button to return to the menu.
5. Use the Up/Down Left/Right button to continue to navigate the Photo Menu for additional changes, or press the menu button to exit the Photo Menu.

-  After selecting a function, you can press the Up button to return to the Still Picture menu for other Photo Setup or Camera Setup pages. Or you can press the Down button several times to move to the next setup menu page.

Refer to the following pages for more details about each setting.

AF Mode (Auto-Focus mode)

Use this setting to control the auto-focus mechanism while taking pictures.



Two options are available:

- **Single-AF:** The focus frame appears in the center of the LCD screen to focus on the subject.
- **Multi-AF:** The camera automatically focuses the subject in a wide area to find the focus point.

AF-assist Beam

This option can turn on or turn off AF assist lamp. The AF assist beam is useful for focusing in the dark or in low lighting conditions.

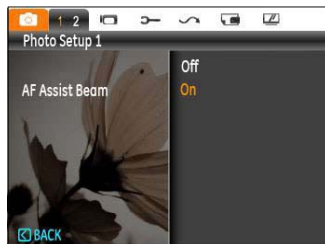

Continuous AF

With Continuous AF is turned on, the camera will continually adjust focus automatically in response to any camera or subject movement.



Expo Metering (Exposure Metering)

Use this setting to select the "target" size of the camera's field of view to be metered.

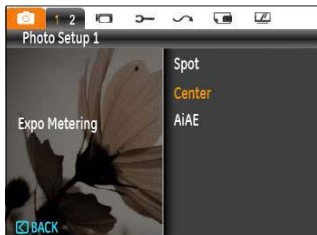

Three metering "target" sizes are available to choose from:

- **Spot** metering targets a small area in the center of the camera's field of view.
- **Center** metering targets a slightly larger area in the center of the camera's field of view.
- **AiAE** (Artificial Intelligence AE) targets the camera's entire field of view.

Continuous Shot

Use this setting to perform continuous shooting. After entering this mode, you can shoot multiple images by continuously holding the shutter button down.

 The flash is designed not to work in this mode in order to enable quick succession of shots.



There are five available options:

- **Off:** Turns off the Continuous Shot function.
- **Unlimited:** Press and hold down the shutter button to shoot continuously until you release the shutter button or when the memory card has run out of space.
- **3 Shots:** Capture up to 3 consecutive pictures.
- **3 Shots (Last):** Capture pictures continuously until the Shutter button is released but only the last 3 shots are recorded.
- **Time Lapse:** Automatically capture pictures at predefined intervals.

Date Imprint

Include a Date/Time stamp in the photo image.

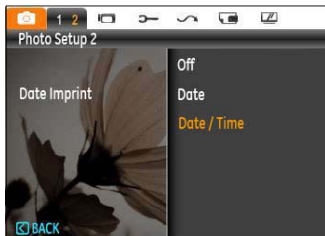

- Off
- Date
- Date / Time

Quick Review

This setting refers to the brief photo review immediately after taking a picture. The picture stays on the LCD screen for an adjustable period of time.

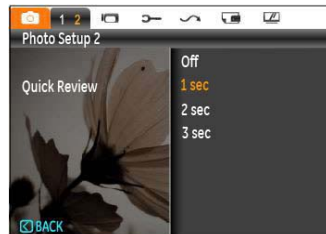

Four options are available:

- Off
- 1 sec
- 2 sec
- 3 sec

Digital Zoom

Use this setting to enable or disable the digital zoom function. When Digital Zoom is turned off, only the optical zoom is functional.

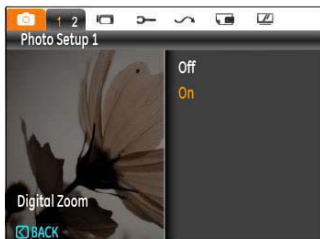

Movie Menu

Mode: 

In the Movie Mode, press the  button to go to the corresponding Movie menu.



To configure each setting:

1. In the Movie menu, switch between the Movie Setup or different Camera Setup pages using the Left/Right button, select the tab with the function you want to adjust and press the Down button.

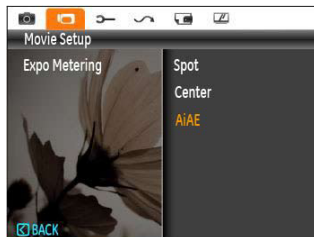

2. Press the Up/Down button to select the function and press the Right button to go to the sub-menu.



3. Press the Up/Down button to select an option or the Left or  button to return to the menu.
4. Press the  button to confirm the setting and return to the previous menu.

Refer to the following pages for more details about each setting.

Continuous AF

After Continuous AF is turned on, the camera will adjust focus automatically in response to any camera or subject movement.

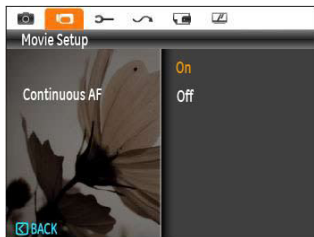

Expo Metering (Exposure Metering)

Set metering mode for various lighting conditions.

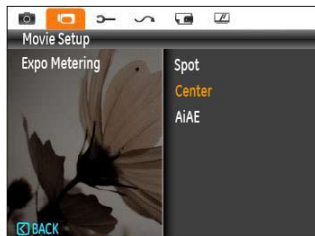

Three options are available:

- Spot
- Center
- AiAE (Artificial Intelligence AE)

Playback Menu

Mode : 

In Playback mode, press the  button to enter the Playback menu.

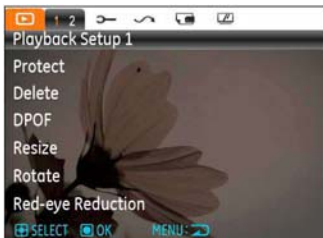



The following section provides detailed instructions on the various menu options.

Protect

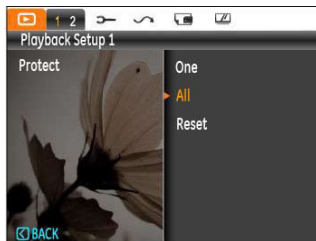
To prevent any pictures or videos from being accidentally erased, use this setting to lock one or all of the files.



To protect/unprotect a picture or video:

1. Use Up/Down arrow button to select Protection, press  or Right button to enter the submenu.
2. Use Up/Down button to select a single picture to lock the selected photo or movie; or select all to protect all photos and movies stored in in-built memory card. Press  button to confirm and enter photo/movie protection interface.

3. Press the  button to select Yes to lock displayed photos or videos, or select De-protection to unlock, then press Up/Down button to select Back to return to the playback menu.





After selecting Reset, all previous protection settings will be cancelled.

Delete

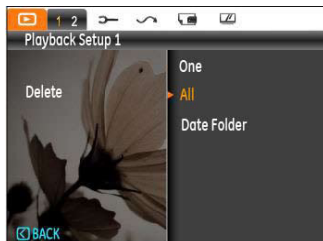
There are three ways to delete files.





• Delete One:



1. In the Delete Option, select One and then press the  button.
2. Press the Left/Right button to locate the photo or video to be deleted. Press the Up/Down button and select yes and press the  to delete the item or select "back" to return to the previous menu.

• Delete All:

1. In the Delete option, select All and then press the  button.
2. Use Up/Down button and select Yes to delete all files, or select Back to return to the menu.

• Delete Date Folder:

1. In the Delete option, press  button after selecting Date Folder.
2. Use the Up/Down button to select Date Folder to be deleted, press  to confirm, press the Up/Down button to select item (Yes: to delete the file, Back: to return to the menu) and then press  to confirm.

 The “” indicator means a file is protected. File protection must be removed first before a file can be deleted.

 Deleting files will cause DPOF settings to be reset.

DPOF (Digital Print Order Format)

DPOF feature allows you to compile a selection of pictures that you would like to have printed, and will save your selection in the memory card so that you can simply hand your memory card to a photo printing service without having to tell them which photos you would like to print.

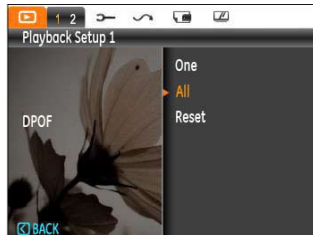

Trim

The Trim setting allows you crop photos and save them as new pictures.

To trim a picture:

1. With the camera in Playback mode press the menu button to access the Photo Menu. Then use the Left/Right button and select the "playback setup 2" tab. Use the Down button to select Trim and press the function button to enter the Trim sub-menu.
2. Using the Left/Right buttons, locate the photo that you want to crop. After the photo is displayed on the LCD screen press the Down button, select Yes and press the function button.
3. Use the zoom buttons and navigation buttons to crop the picture.



4. Press the function button and a 'Save Changes?' prompt will display. Select "O" to confirm changes and save it as a new image, or select "X" to cancel changes and return to the previous menu.



The image can not be clipped again once it has been clipped to 640X480.

HDR-High Dynamic Range

With the HDR function, pictures that are overexposed may be corrected to optimize the highlights and lowlights captured to more accurately represent the real scene.

1. Select HDR setting in Playback menu as described previously.
2. Press Left and Right button to find picture you want to optimize and then select Confirm to perform HDR optimization or select Return to go back to Playback menu.

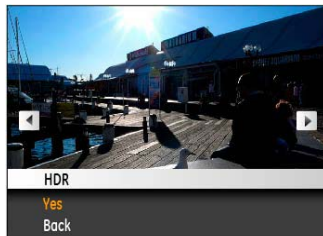

3. After using the HDR function, the image will be saved as a new file, and the original file is still stored in the memory.

Resize

This setting allows you to resize a picture to a specified resolution, and saves it as a new picture.

1. Select the **Resize** setting from the **Playback** menu as described previously.



2. Use the **Left/Right** navigation buttons to select a picture to resize.
3. Use the **Up/Down** navigation buttons to select a resolution (**1024X768** or **640X480**) to resize the image or **Back** to cancel and return to the **Playback** menu.
4. Press the **func** button to confirm the setting.



Resizing an image creates a new file that contains the image in the size you select. The file with the original image also remains in the memory.

Rotate

You can use this setting to change the orientation of the picture.

1. Select the **Rotate** setting from the **Playback** menu as described previously.
2. Use the **Left/Right** navigation buttons to select a picture to rotate.
3. Use the **Up/Down** navigation buttons to select the direction of rotation or **Back** to cancel and return to the **Playback** menu.

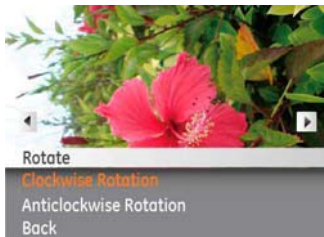

4. Press the **func** button to confirm the setting.



Panoramic photos cannot be rotated.

Red-eye Reduction

Use this setting to remove red-eye effect in your photos.

1. Select the **Red-eye Reduction** in the **Playback** menu as described previously.
2. Use the **Left/Right** button to select the picture that requires red eye removal.
3. Use the **Up/Down** navigation buttons and select **Yes** to fix the selected image or **Back** to cancel and return to the **Playback** menu.



4. Press the **fire ok** button to confirm the setting.



For best results, the face of the subject should be relatively large in the LCD screen, the subject should be facing the camera and the red-eye effect should be clearly visible.

Display Setup

Mode:



Press the **main** button in **Playback** mode to enter the **Display Setup** menu.



Refer to the following sections for details of every setting.

Slideshow

This setting allows you to view all the stored pictures as a slideshow.

1. Select Slideshow and press the Right button to enter the Slideshow options menu.
2. Press Up/Down button to select effect, interval or repeat, and press  or Right button to enter and adjust settings. Press  button to confirm settings.



3. Use the Up/Down navigation buttons to select Start to run the slideshow or Cancel to return to the Playback menu.
4. Press the  button to confirm the setting.

Wallpaper Settings

Use this setting to select your favorite picture to use as a background on the LCD screen.



1. Press the Down button to select the Wallpaper Setting menu.



2. Press Right, and the camera will enter the Wallpaper Setting interface.



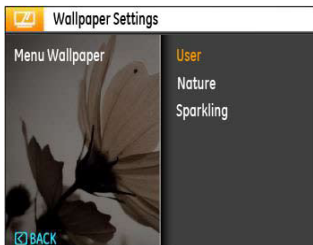

Menu Wallpaper:

From the Display Setup tab use the Up/Down button to select the Wallpaper Settings option, press the  button then press Right to enter the  wallpaper sub-menu. Press Right and select either User, Nature, or Sparkling. Press function  to confirm the setting.



- User
- Nature
- Sparkling



Startup Screen:

Use UP/Down button to select the Welcome Wallpaper option, press  or Right button to select the welcome wallpaper, press Left button to return to last page, and press  to exit the menu.



- User
- GE Logo

Back To Default:

Use Up/Down button to select the Back to Default option, press the  or Right button to select whether to take the default settings, press Left Button to return to last page, and press  to exit the menu.

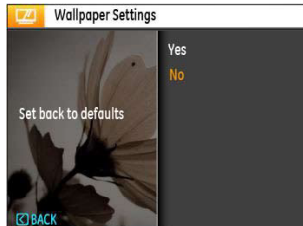

- Yes
- No

Setup Menu

Mode :  ASCN P S A    SCN

The Setup menu for the camera is available in all modes. Each menu page can be selected by pressing the  button and switching between tabs with the Left/Right button.



To adjust the settings:

1. Select the menu tab that corresponds with the function you want to adjust and press the Down button.
2. Switch between different functions with the Up/Down button.
3. Press the Right button to enter the sub-menu.



After selecting a function option, you can press the Up button to return to the menu for other Camera Setup pages. Or you can press the Down button to switch to the next menu page.

Refer to the following pages for more details about each setting.

Beep

Use this setting to adjust the volume of the beep emitted when buttons are pressed and change the tones for the Shutter button, self-timer, and power-on/power-off.

To change this setting:

1. Select the **Beep** setting from the **Setup** menu as described previously.
2. Use the **Up/Down** navigation buttons to switch between volume, shutter, key, self-timer, and power tone fields.

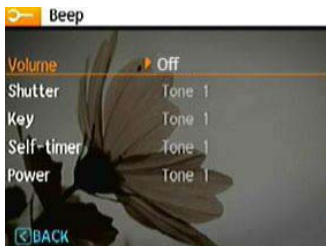

3. Press the Right button, then press the Up/Down button to adjust the volume or change the tone, and press the  button to confirm the setting.

LCD Brightness

Use this setting to adjust the brightness of your LCD screen.

1. Select the **LCD Brightness** setting from the **Setup** menu as described previously.
2. Select auto or adjust the brightness level using the Left/Right button, and press the  button to confirm the setting.



Power Saver

This setting allows you to save power and get the maximum possible running time for your batteries. Follow the steps below to turn off the LCD screen and camera automatically after a period of inactivity.

1. Select the **Power Save** setting from the **Setup** menu as described previously.
2. Press the Up/Down button to select the power items for the screen and camera and press the Right button.





3. Press the Up/Down button to adjust the selected item. Both items have the following options:

- LCD off:
On, 30 sec, 1 Min, 2 Min.
 - Camera off:
On, 3 Min, 5 Min, 10 Min.
4. Press the  button to confirm.

Zone

The Zone setting is a useful function on your overseas trips. This feature enables you to display the local time on the LCD screen while you are overseas.

1. Select the **Zone** setting from the **Setup** menu as described previously. The world time screen will appear.
2. Use the **Up/Down** navigation buttons to switch between the hometown () and travel destination () fields.
3. Use the **Left/Right** navigation buttons to select a city close to the desired time zone. Then press the  button to confirm.



Date/Time

See “Setting the Date and Time” section on page 15.

Language

See “Setting the Language” section on page 14.

File / Software

Format Memory

Please note: formatting enables you to delete all contents in the memory card and built-in memory, including protected photo and movie files.

To use this setting:

1. Select Format Memory in the File/Software menu, then press Right.
2. Use the Up/Down navigation buttons to select Yes or No. Then press the  button to confirm the setting.



3. The current media is formatted.

File Numbering

After you take a picture or video clip, the camera will save it as file that ends with a serial number. You can use this item to choose whether the file is serially numbered or begins with 1 and is saved in another folder on the memory card.

1. Select File Numbering in the File/Software menu, then press Right.
2. Select the option with the Up/Down button and press the  button for confirmation.

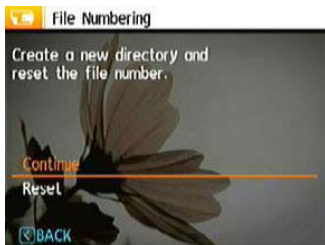

Copy to Card (Copy internal memory to memory card)

Use this setting to copy the files stored in the internal memory to the memory card.

1. Select Copy to Card in the File/Software menu, then press Right.
2. Use the Up/Down navigation buttons to select Yes or No. Then press the  button to confirm the setting.



Reset Settings

Use this setting to restore the camera to its default settings.

1. Select Reset Settings in the File/Software menu, then press Right.
2. Use the Up/Down navigation buttons to select Yes or No. Then press the  button to confirm the setting.



FW Version (Firmware Version)

Use this setting to view the current camera firmware version.

Select FW Version in the File/Software menu, then press Right.



To update to the latest firmware version, you can go to the following website: www.ge.com/digitalcameras and look under Support.

CONNECTIONS

Video System

Use this feature to switch the video system from either NTSC or PAL.

1. Select **Video System** in the Transmission menu, then press Right.
2. Use the **Up/Down** navigation buttons to select **NTSC** or **PAL**. Then press the  button to confirm.

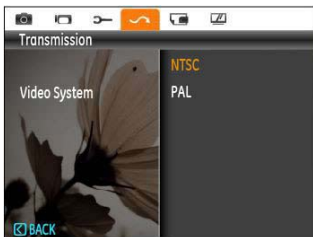

The video output signal can be switched to NTSC or PAL to accommodate different regional standards. The appropriate setting will vary between regions.

NTSC: USA, Canada, Taiwan, Japan, etc.

PAL: Europe, Asia (excluding Taiwan), Oceania, etc.

Note: The TV output will not display properly if an incorrect video system is selected.

Connecting to a PC

Use the USB cable and ArcSoft software (CD-ROM) supplied with your camera to copy (transfer) pictures to a computer.

Setting the USB mode

Since the camera's USB port can be set to connect with either a PC or a Printer, the following steps will allow you to ensure that the camera is correctly configured to connect with a PC.

1. Go to the Transmission menu, then select USB connection with the Up/Down button, and press the Right button.
2. Use the **Up/Down** navigation buttons to select **PC**.
3. Press the  button to confirm the setting.

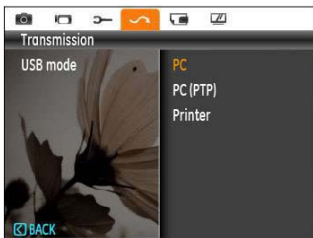

Transferring files to your PC

The computer will automatically detect the camera as a removable drive. Double-click the **My Computer** icon on the desktop to locate the removable drive and to copy folders and files in the drive to a directory on your PC as you would copy any typical folder or file.

By using the USB cable, you can transfer the captured photos and videos to a PC. Follow the steps below to connect the camera to a PC.

1. Start a computer in which ArcSoft software has been installed.
2. Make sure both the camera and PC are turned on.
3. Connect one end of the supplied USB cable to the USB/AV OUT port on your camera.
4. Connect the other end of the cable to an available USB port on your PC.

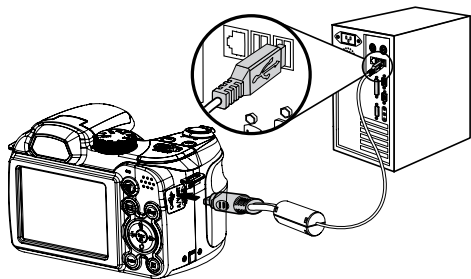

5. Disconnect the camera once transfer is completed.

If the USB option is set to [PC] :

Turn the camera off and disconnect the USB cable.

If the USB option is set to [PC (PTP)] :

Remove the camera from the system as described below before turning the camera off and disconnecting the USB cable.

Windows operating system (Windows 2000, Windows XP, Windows Vista, Windows 7.)

Click the [Safely remove the hardware] icon and remove the USB connector according to the appeared menu.

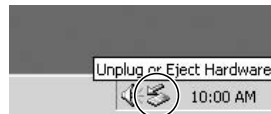

Macintosh

Drag the untitled icon to the Trash. ("Untitled")



Connecting to a PictBridge Compatible Printer



PictBridge allows printing images from a memory card in a digital camera directly to a printer, regardless of brand. To find out if a printer is PictBridge compatible, simply look for the PictBridge logo on the packaging or check

the manual for specifications. With the PictBridge function on your camera, you can print the captured photos directly to a PictBridge compatible printer using the supplied USB cable, without the need for a PC.

Setting the USB mode

Since the camera's USB port can be set to connect with either a PC or a Printer, the following steps will ensure that the camera is correctly configured to connect with a Printer.

1. Go to the camera's Transmission menu and, select USB connection with the Up/Down button, then press the Right button.
2. Use the Up/Down button and select Printer.

3. Press the  button to confirm the setting.

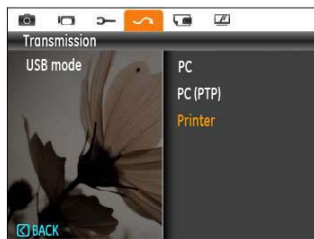

After the camera is reset, it will switch to PC mode automatically from USB mode.

Connecting the camera and printer.

1. Make sure both the camera and printer are turned on.
2. Connect one end of the supplied USB cable to the USB port on your camera.
3. Connect the other end of the cable to the USB port on the printer.

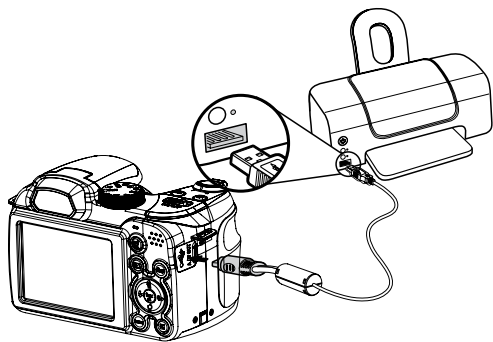

If the camera is not connected to a PictBridge compatible printer, the following error message will appear on the LCD screen.



-  The above error message would also appear if the USB mode were set incorrectly, in which case you should disconnect the USB cable, check the USB mode settings, ensure that the Printer is turned on, and then try connecting the USB cable again.

Using the PictBridge Menu

After setting the USB mode to Printer, the **PictBridge** menu will appear.



Select a menu item with the Up/Down button and press the Right button or  button to enter the item.

Refer to the following sections for more detailed information on each setting.

Print with date

If you have set the date and time on your camera, the date and time will be recorded and saved with each photo you take.

1. Select **Print with date** from the **PictBridge** menu. The following screen will appear.

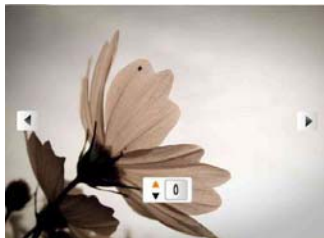

2. Use the **Left/Right** navigation buttons to scroll through the photos.

- Use the **Up/Down** navigation buttons to select the number of prints for the current displayed photo.
- Press the  button and the following screen will appear.





- Select Yes to print or exit, then press  button again.

Print without date

Use this setting to print the photos without dates on them.

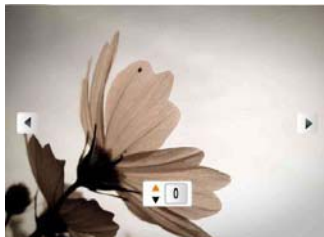
- Select **Print without date** from the PictBridge menu. The following screen appears.



- Use the **Left/Right** navigation buttons to scroll through the images.
- Use the **Up/Down** navigation buttons to select the number of prints for the current displayed image.
- Press the  button and the following screen will appear.



5. Select Yes to print or exit, then press the  button again.

Print index

You can use this setting to print an index of all the photos currently in your camera's memory.

1. Select **Print index** from the **PictBridge** menu. The following screen will appear.



2. Select Yes to print or exit, then press the  button again.

Print DPOF (Digital Print Order Format)

To use DPOF printing, you must make the selection of photos for printing using the DPOF settings beforehand. See “DPOF” section on page 56.

1. Select **Print DPOF** from the **PictBridge** menu. The following screen will appear.



2. Select **Yes** to print or exit, then press the  button again.

Exit

To exit the **PictBridge** menu, select **Exit**. The “Remove USB cable” message will be displayed.



Disconnect the USB cable from the camera and printer.

APPENDICES

Specifications



Design and specifications are subject to change without notice.

Effective Image Sensor Pixels		16.0 Megapixels
Image Sensor		16.5 Megapixels [1/2.3" (CCD)]
Lens	Focal Length F =	4.9mm (Wide) ~ 73.5mm (Tele)
	35mm film equivalent	27mm (Wide) ~ 405mm (Tele)
	F number	F3.0 (Wide) ~ F5.2 (Tele)
	Construction	14 elements in 11 groups
	Optical Zoom	15X
	Focusing Range	Normal: (Wide) 60cm ~ ∞, (Tele) 200cm ~ ∞; Macro: (Wide) 5cm ~ ∞, (Tele) 200cm ~ ∞
Anti-Handshake		OIS
Digital Zoom		6X digital zoom (Combined Zoom: 90X)

Number of Recording Pixels	Still Image	16MP, 12MP(16:9), 8MP, 5MP, 3MP, 2MP(16:9), 0.3MP
	Movie	640x480pixels: 30fps/15fps, 320x240pixels: 30fps/15fps
Image Compression		Best, Fine, Normal
DCF, DPOF (Ver1.1) Support		Yes
File Format	Still Image	Exif 2.2 (JPEG)
	Movie	Quick Time Motion JPEG, Audio: G.711 [Monaural]
Shooting Modes		Auto, Manual, Auto Scene, Scene (Sport, Indoor, Snow, Fireworks, Museum, Night Landscape, Children, Leaf, Sunset, Glass, Landscape, Night Portrait, Beach, Text, Gathering, ID, Fish eye, Travel shooting, Photo frame, Sketch), Program Auto Exposure, Shutter Priority, Aperture Priority, Portrait, Panorama and Video Chip
Smile Detection		Yes
Blink Detection		Yes
Face-Detection		Yes
Red-eye Removal		Yes

Pan-Capture Panorama	Yes
LCD Display	2.7 inch (230,400 pixels) LTPS (low-temperature polycrystalline silicon) TFT color LCD
ISO Sensitivity	Auto, ISO80/100/200/400/800/1600/3200
AF Method	Single AF, Multi-AF (TTL 13-point), AF Assist Light (On/Off)
Light Metering Method	Artificial Intelligence AE (AiAE), Center-weighted Average, Spot (Fixed to center of frame)
Exposure Control Method	ProgramAE (AE-lock available)
Exposure Compensation	±2 EV in 1/3 Step increments
Shutter Speed	4 ~ 1/2000 second (Manual 30 s)
Continuous Shooting	Approx. 1.39 fps (Large/Fine mode)
Playback Modes	Single Photo, Index (9/16 thumbnails), Slide Show, Movie (Slow-Motion possible), Zoom (Approx. 2X~8X), Audio, Histogram Display
White Balance Control	Auto (AWB), Daylight, Cloudy, Fluorescent , Fluorescent CWF, Incandescent, Manual

Internal Flash (Shooting Range)	Auto/Red-Eye Reduction/Forced Flash/No Flash/Slow Synchro/Red-Eye Reduction+Slow Synchro
	Shooting Range Wide: Approx. 0.3m~7.0m / Tele: Approx. 1.2m ~ 4.0m
Recording Media	Internal Memory: 13.7MB
	SD Card/SDHC Card (Up to 16GB support)
Other Features	PictBridge, ExifPrint Support, Multi-language Support
Jacks	USB2.0/AV-OUT
Power	4 x AA Alkaline Battery, AA NiMH Battery [Not Included]
Shooting Capability (Battery Performance)	AA Alkaline Batteries: Approx. 300 shots (based on CIPA standards)
	AA NiMH Battery : Approx. 500 shots (CIPA Standards)
Operation Environment	Temperature: 0~40°C, Humidity: 0~90%
Dimensions (W x H x D)	103mm x 74mm x 68 mm
Mass	Approx. 350g (Body only)

Error messages

Messages	Explanation
No card	<ul style="list-style-type: none">• The memory card is not inserted.
Card error	<ul style="list-style-type: none">• The memory card is not formatted.
Card full	<ul style="list-style-type: none">• The memory card is full and cannot store any new images.
Write protect	<ul style="list-style-type: none">• The memory card is write-protected.
Picture error	<ul style="list-style-type: none">• The picture is not captured correctly.• The picturefile is corrupted.
No picture	<ul style="list-style-type: none">• There are no images in the memory card or in the internal memory.
Lens error	<ul style="list-style-type: none">• The lens is probably stuck and the camera will power off automatically.
System error	<ul style="list-style-type: none">• Unexpected error encountered.
Image cannot be saved	<ul style="list-style-type: none">• The write protection switch in the memory card is set to the "LOCK" position.
Out of the range	<ul style="list-style-type: none">• When pictures were taken in Panorama mode, the direction of movement was incorrect or the angle was outside the range of the internal settings.

Messages	Explanation
Card is not formatted, format?	<ul style="list-style-type: none"> • Confirm whether or not the memory card should be formatted.
This image cannot be deleted	<ul style="list-style-type: none"> • The picture or video you are trying to delete is protected.
Cannot record movie	<ul style="list-style-type: none"> • The write protection switch in the memory card is set to the "LOCK" position.
Warning!! Camera recording, please wait.	<ul style="list-style-type: none"> • No other actions allowed to perform during video/audio recording.
Warning!! Battery exhausted.	<ul style="list-style-type: none"> • The battery is out of charge.
This file cannot be played back	<ul style="list-style-type: none"> • The picture format cannot be recognized by the camera.
No connection	<ul style="list-style-type: none"> • The camera is not connected to the printer correctly.
Print error	<ul style="list-style-type: none"> • There is a problem with the camera or printer.
Cannot print	<ul style="list-style-type: none"> • Check that the printer is out of paper or out of ink. • Check if the printer has a paper jam.

Troubleshooting

Problem	Possible causes	Solution
Camera does not turn on.	<ul style="list-style-type: none">• The battery has run out.• The battery is not inserted correctly.	<ul style="list-style-type: none">• Replace with a fully charged battery.• Check the positive and negative are correct when installing the battery.
Camera turns off suddenly during operation.	<ul style="list-style-type: none">• The battery has run out.	<ul style="list-style-type: none">• Replace with a fully charged battery.
The picture is blurred.	<ul style="list-style-type: none">• The lens is dirty.•  appears when taking pictures.	<ul style="list-style-type: none">• Use a soft cloth to clean the lens on your camera• Use the Image Stabilization mode.
Images and video files cannot be saved.	<ul style="list-style-type: none">• The memory card is full.	<ul style="list-style-type: none">• Replace the memory card with a new one.• Delete unwanted images.• Unlock the memory card.

Problem	Possible causes	Solution
No picture is taken when pressing the Shutter button.	<ul style="list-style-type: none"> • The memory card is full. • No available space to store the files. • The Mode dial is in Playback mode. 	<ul style="list-style-type: none"> • Replace the memory card with a new one or erase the current memory card. • Delete unwanted images. • The memory card is locked. • Turn the mode dial to a picture taking mode.
Images cannot print from the connected printer.	<ul style="list-style-type: none"> • The camera is not connected to the printer correctly. • The printer is not PictBridge compatible. • The printer is out of paper or out of ink. • The paper is jammed. 	<ul style="list-style-type: none"> • Check the connection between the camera and printer. • Use a PictBridge compatible printer. • Load some paper in the printer. • Replace the ink cartridge in the printer. • Remove the jammed paper.

<http://www.ge.com/digitalcameras>

