

ART 201/63A+/NF

12NC: 859991013660

EAN code: 8003437041549



SENSING THE DIFFERENCE

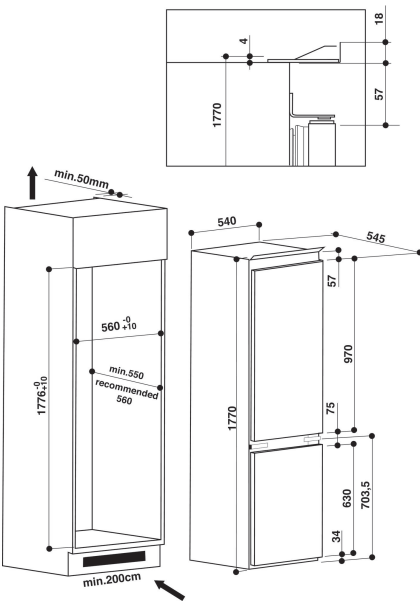

MAIN FEATURES

Product group	Fridge/freezer combination
Installation type	Built-in
Type of control	Electronic
Construction type	Built-in
Main colour of product	White
Connection rating (W)	160
Current (A)	16
Voltage (V)	220-240
Frequency (Hz)	50
Number of compressors	1
Length of Electrical Supply Cord (cm)	245
Plug type	UK
Total unit net capacity (l)	264
Star Rating	4
Height of the product	1770
Width of the product	540
Depth of the product	545
Maximum adjustability feet	0
Net weight (kg)	58

TECHNICAL FEATURES

Defrost process fridge section	Automatic
Defrost process freezer section	Automatic
Fast cooling switch	No
Fast freezing function	Yes
Door opened indicator freezer	No
Temperature adjustable	Yes
Temperature adjustable freezer	Yes
Interior ventilator fridge section	Yes
Number of freezing drawers	3
Automatic motor-driven ice-maker	No
Number of shelves in fridge compartment	5
Material of the shelves	Glass
Thermometer fridge section	None
Thermometer freezer section	None
Number of temperature zones	1

PERFORMANCES

Energy efficiency class - NEW (2010/30/EC)	A+
Energy consumption annual (kWh/annum) - NEW (2010/30/EC)	297
Refrigerator Net capacity (l) - NEW (2010/30/EC)	201
Freezer Net capacity (l) - NEW (2010/30/EC)	63
Freezing capacity (kg/24h) - NEW (2010/30/EC)	6
Climate class	SN-T
Noise level (dB(A) re 1 pW)	38
Frost free system	Freezer