

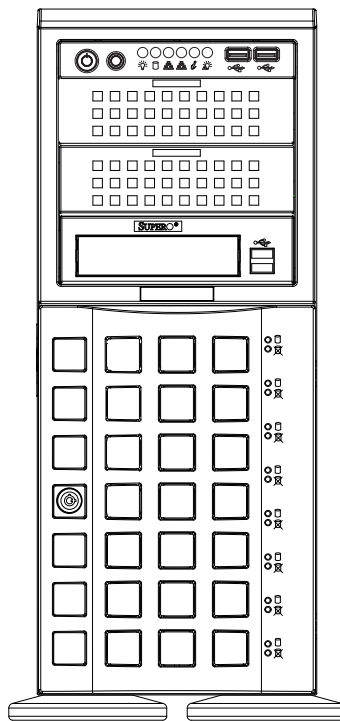

SuperServer[®]
7049P-TR
7049P-TRT



USER'S MANUAL

Revision 1.0a

The information in this User's Manual has been carefully reviewed and is believed to be accurate. The vendor assumes no responsibility for any inaccuracies that may be contained in this document, and makes no commitment to update or to keep current the information in this manual, or to notify any person or organization of the updates. **Please Note: For the most up-to-date version of this manual, please see our website at www.supermicro.com.**

Super Micro Computer, Inc. ("Supermicro") reserves the right to make changes to the product described in this manual at any time and without notice. This product, including software and documentation, is the property of Supermicro and/or its licensors, and is supplied only under a license. Any use or reproduction of this product is not allowed, except as expressly permitted by the terms of said license.

IN NO EVENT WILL Super Micro Computer, Inc. BE LIABLE FOR DIRECT, INDIRECT, SPECIAL, INCIDENTAL, SPECULATIVE OR CONSEQUENTIAL DAMAGES ARISING FROM THE USE OR INABILITY TO USE THIS PRODUCT OR DOCUMENTATION, EVEN IF ADVISED OF THE POSSIBILITY OF SUCH DAMAGES. IN PARTICULAR, SUPER MICRO COMPUTER, INC. SHALL NOT HAVE LIABILITY FOR ANY HARDWARE, SOFTWARE, OR DATA STORED OR USED WITH THE PRODUCT, INCLUDING THE COSTS OF REPAIRING, REPLACING, INTEGRATING, INSTALLING OR RECOVERING SUCH HARDWARE, SOFTWARE, OR DATA.

Any disputes arising between manufacturer and customer shall be governed by the laws of Santa Clara County in the State of California, USA. The State of California, County of Santa Clara shall be the exclusive venue for the resolution of any such disputes. Supermicro's total liability for all claims will not exceed the price paid for the hardware product.

FCC Statement: This equipment has been tested and found to comply with the limits for a Class A digital device pursuant to Part 15 of the FCC Rules. These limits are designed to provide reasonable protection against harmful interference when the equipment is operated in a commercial environment. This equipment generates, uses, and can radiate radio frequency energy and, if not installed and used in accordance with the manufacturer's instruction manual, may cause harmful interference with radio communications. Operation of this equipment in a residential area is likely to cause harmful interference, in which case you will be required to correct the interference at your own expense.

California Best Management Practices Regulations for Perchlorate Materials: This Perchlorate warning applies only to products containing CR (Manganese Dioxide) Lithium coin cells. "Perchlorate Material-special handling may apply. See www.dtsc.ca.gov/hazardouswaste/perchlorate".

WARNING: Handling of lead solder materials used in this product may expose you to lead, a chemical known to the State of California to cause birth defects and other reproductive harm.

The products sold by Supermicro are not intended for and will not be used in life support systems, medical equipment, nuclear facilities or systems, aircraft, aircraft devices, aircraft/emergency communication devices or other critical systems whose failure to perform be reasonably expected to result in significant injury or loss of life or catastrophic property damage. Accordingly, Supermicro disclaims any and all liability, and should buyer use or sell such products for use in such ultra-hazardous applications, it does so entirely at its own risk. Furthermore, buyer agrees to fully indemnify, defend and hold Supermicro harmless for and against any and all claims, demands, actions, litigation, and proceedings of any kind arising out of or related to such ultra-hazardous use or sale.

Manual Revision 1.0a

Release Date: September 13, 2017

Unless you request and receive written permission from Super Micro Computer, Inc., you may not copy any part of this document. Information in this document is subject to change without notice. Other products and companies referred to herein are trademarks or registered trademarks of their respective companies or mark holders.

Copyright © 2016 by Super Micro Computer, Inc.
All rights reserved.

Printed in the United States of America

Preface

About this Manual

This manual is written for professional system integrators and PC technicians. It provides information for the installation and use of the SuperServer 7049P-TR(T). Installation and maintenance should be performed by experienced technicians only.

Please refer to the 7049P-TR(T) server specifications page on our website for updates on supported memory, processors and operating systems (<http://www.supermicro.com>).

Notes

For your system to work properly, please follow the links below to download all necessary drivers/utilities and the user's manual for your server.

- Supermicro product manuals: <http://www.supermicro.com/support/manuals/>
- Product drivers and utilities: <ftp://ftp.supermicro.com>
- Product safety info: http://www.supermicro.com/about/policies/safety_information.cfm

If you have any questions, please contact our support team at:
support@supermicro.com

This manual may be periodically updated without notice. Please check the Supermicro website for possible updates to the manual revision level.

Warnings

Special attention should be given to the following symbols used in this manual.



Warning! Indicates important information given to prevent equipment/property damage or personal injury.



Warning! Indicates high voltage may be encountered when performing a procedure.

Contents

Chapter 1 Introduction

1.1 Overview.....	8
1.2 Unpacking the System	8
1.3 System Specifications	9
1.4 Server Chassis Features.....	10
Control Panel	10
Front Features.....	11
Rear Features	12
1.5 Motherboard Layout	13

Chapter 2 Rack Mount Installation

2.1 Overview.....	17
2.2 Preparing for Rack Mounting	17
Choosing a Setup Location.....	17
Rack Precautions	17
Server Precautions.....	18
Rack Mounting Considerations	18
Ambient Operating Temperature.....	18
Airflow	18
Mechanical Loading.....	18
Circuit Overloading	19
Reliable Ground.....	19
2.3 Chassis Preparation	20
2.4 Installing the Rails	21
Identifying the Rails	21
Releasing the Inner Rails.....	21
Installing the Inner Rails	22
Assembling and Installing the Outer Rails.....	23
2.5 Installing the Server into the Rack.....	24
Removing the Chassis from the Rack	25
2.6 Control Panel Orientation.....	26

Chapter 3 Maintenance and Component Installation

3.1 Removing Power	28
3.2 Accessing the System.....	29
3.3 Motherboard Components.....	30
Processor and Heatsink Installation.....	30
The Xeon Scalable Processor	30
Overview of the Processor Socket Assembly.....	31
Heatsinks	32
Overview of the Processor Heatsink Module (PHM).....	33
Assembling the Processor Package.....	34
Assembling the Processor Heatsink Module (PHM)	36
Preparing the CPU Socket for Installation.....	37
Installing the Processor Heatsink Module (PHM)	38
Connecting an HFI Carrier Card	39
Removing the Processor Heatsink Module from the Motherboard	40
Memory	41
Memory Support	41
DIMM Module Population Configuration.....	41
Install Procedure.....	43
PCIe M.2 Slot.....	44
Motherboard Battery	45
3.4 Chassis Components	46
Storage Drives	46
Drive Indicators	46
Installing the Standard 3.5" Drives	47
Configuring the 5.25" Drive Bays.....	49
Additional Storage Drives in a Mobile Rack.....	52
Installing Expansion Cards.....	54
System Cooling	55
Chassis Fans	55
Air Shroud.....	56
Power Supply	57
Power Supply LEDs.....	57
Removing the Front Bezel	58

Chapter 4 Motherboard Connections

4.1 Power Connections	59
4.2 Headers and Connectors	60
Control Panel	64
Data Cables	66
4.3 Input/Output Ports and Interface Buttons.....	67
4.4 Jumpers.....	68
Explanation of Jumpers	68
4.5 LED Indicators.....	70

Chapter 5 Software

5.1 OS Installation	72
Installing the Windows OS for a RAID System	72
Installing Windows to a Non-RAID System	72
5.2 Driver Installation.....	73
5.3 SuperDoctor® 5.....	74
5.4 IPMI	75

Chapter 6 BIOS

6.1 Introduction.....	76
Starting BIOS Setup Utility.....	76
6.2 Main Setup	76
6.3 Advanced Setup Configurations.....	78
6.4 Event Logs	103
6.5 IPMI	105
6.6 Security.....	107
6.7 Boot	110
6.8 Save & Exit.....	113

Appendix A BIOS Error Codes

Appendix B Standardized Warning Statements for AC Systems

Appendix C System Specifications

Appendix D UEFI BIOS Recovery

Contacting Supermicro

Headquarters

Address: Super Micro Computer, Inc.
980 Rock Ave.
San Jose, CA 95131 U.S.A.

Tel: +1 (408) 503-8000

Fax: +1 (408) 503-8008

Email: marketing@supermicro.com (General Information)
support@supermicro.com (Technical Support)

Website: www.supermicro.com

Europe

Address: Super Micro Computer B.V.
Het Sterrenbeeld 28, 5215 ML
's-Hertogenbosch, The Netherlands

Tel: +31 (0) 73-6400390

Fax: +31 (0) 73-6416525

Email: sales@supermicro.nl (General Information)
support@supermicro.nl (Technical Support)
rma@supermicro.nl (Customer Support)

Website: www.supermicro.nl

Asia-Pacific

Address: Super Micro Computer, Inc.
3F, No. 150, Jian 1st Rd.
Zhonghe Dist., New Taipei City 235
Taiwan (R.O.C)

Tel: +886-(2) 8226-3990

Fax: +886-(2) 8226-3992

Email: support@supermicro.com.tw

Website: www.supermicro.com.tw

Chapter 1

Introduction

1.1 Overview

This chapter provides a brief outline of the functions and features of the 7049P-TR(T). The 7049P-TR(T) is based on the X11DPi-N(T) motherboard and the SC745BAC-R1K28B chassis.

The server offers two network ports:

- The 7049P-TR model supports 1 Gbps.
- The 7049P-TRT model supports 10 Gbps.

In addition to the motherboard and chassis, several included parts are listed below.

Main Parts List		
Description	Part Number	Quantity
Power Supply	PWS-1K28P-SQ	2
SAS/SATA hard drive backplane	BPN-SAS3-743A	1
Heatsink (passive)	SNK-P0068PS	2
Rear exhaust fans	FAN-0180L4	2
Mid-chassis fans	FAN-0182L4	3
Air shroud	MCP-310-49001-0N	1
Carriers for hot-swap hard drives	MCP-220-00092-0B	8
Chassis rail kit (<i>optional</i>)	CSE-PT26L-B	1

1.2 Unpacking the System

Inspect the box the server was shipped in and note if it was damaged in any way. If any equipment appears damaged, file a damage claim with the carrier who delivered it.

1.3 System Specifications

The following table provides an overview of the main features of the 7049P-TR(T) server. Refer to Appendix C for additional specifications.

System Specifications
Motherboard
X11DPi-N (7049P-TR), X11DPi-NT (7049P-TRT)
Chassis
SC745BAC-R1K28B
CPU
Supports dual Intel 81xx/61xx/51xx/41xx/31xx series (Socket P0) processors which offer Intel UltraPath Interconnect (UPI) of up to 10.4 GT/s
Memory
Supports up to 2 TB of 3DS LRDIMM/LRDIMM/3DS RDIMM/RDIMM/NV-DIMM DDR4 (288-pin) ECC 2666/2400/2133 MHz modules in 16 slots; up to 256 GB size
Chipset
Intel C620 Series
Expansion Slots
Six PCI-Express 3.0 slots: four x16 and two x8
Input/Output
Network: Two LAN ports--7049P-TR model 1 Gbps, or 7049P-TRT model 10 Gbps IPMI: One dedicated LAN port USB: Two USB 3.0 ports, two USB 2.0 port, additional ports optional COM: One VGA: One Optional additional drives and I/O ports available as kits
Storage Drives
Up to eight SATA3 3.5" hot-swap drives, or optionally, 2.5" drives with converters
Power
Redundant 1000/1280 W power supply, 80Plus Platinum level
Cooling
Three 8-cm 11K RPM, 4-pin PWM mid-chassis fans; two 8-cm exhaust fans; one airflow shroud, two CPU heatsinks
Form Factor
4U Tower; Dimensions (WxHxD) 7.0 x 19 x 27 in. (178 x 483 x 686 mm)

1.4 Server Chassis Features

Control Panel

The switches and LEDs located on the control panel are described below. See Chapter 4 for details on the control panel connections.

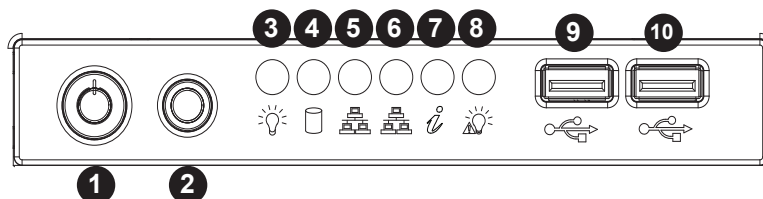

Figure 1-1. Control Panel View

Control Panel Features		
Item	Feature	Description
1	Power Button	The main power button is used to apply or remove power from the power supply to the server. Turning off system power with this button removes the main power but maintains standby power. To perform many maintenance tasks, you should also unplug the system's AC power cord before servicing.
2	Reset Button	The reset button is used to reboot the system.
3	Power LED	Indicates power is being supplied to the system power supply. This LED should normally be illuminated when the system is operating.
4	HDD LED	Indicates hard drive activity when flashing.
5	NIC1 LED	Indicates network activity on LAN port 1 when flashing.
6	NIC2 LED	Indicates network activity on LAN port 2 when flashing.
7	Information LED	See table below for details.
8	Power Fail LED	This LED flashes to indicate one of the redundant power supply modules has failed. The flashing light should be accompanied by an audible warning.
9	USB0 Port	USB 3.0 port
10	USB1 Port	USB 3.0 port

Information LED	
Status	Description
Continuously on and red	An overheat condition has occurred. (This may be caused by cable congestion.)
Blinking red (1Hz)	Fan failure, check for an inoperative fan.
Solid blue	Local UID has been activated. Use this function to locate the server in a rackmount environment.
Blinking blue	Remote UID is on. Use this function to identify the server from a remote location.

Front Features

The SC745BAC-R1K28B is a tower chassis. See the illustration below for the features included on the front of the chassis.

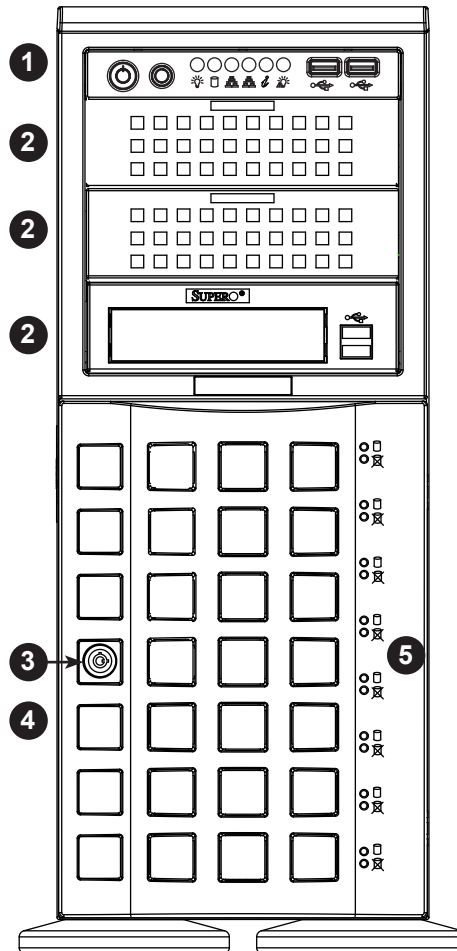

Figure 1-2. Chassis Front View

Front Chassis Features		
Item	Feature	Description
1	Control Panel	Front control panel with LEDs and buttons (see preceding page)
2	Peripheral Drive Bays	Three 5.25" bays for optional peripherals such as a DVD drive
3	Lock	Front bezel lock
4	Drive Bays	Eight 3.5" bays for hot-swap hard drives behind front bezel
5	Drive Indicators	Eight pairs of LED status indicators for drives

Rear Features

The illustration below shows the features included on the rear of the chassis.

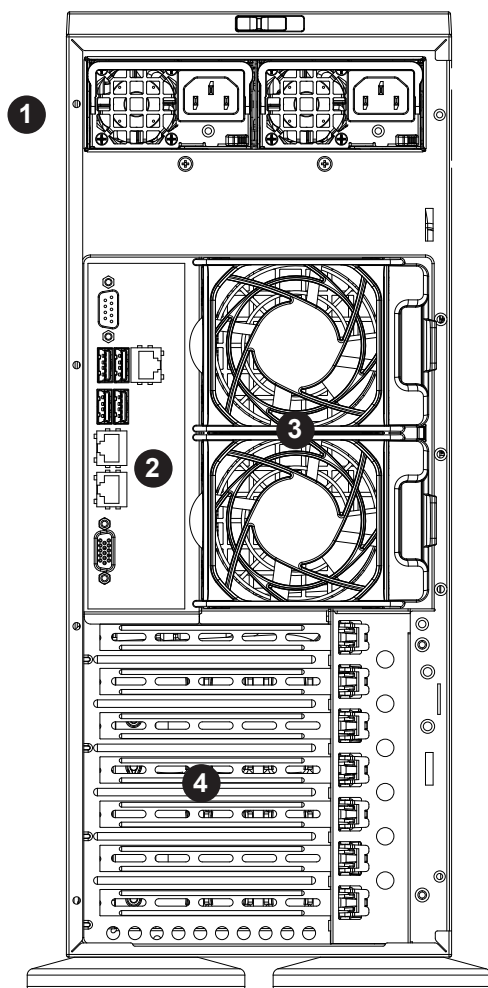

Figure 1-3. Chassis Rear View

Rear Chassis Features		
Item	Feature	Description
1	Power Supply	Redundant 1280 W Platinum Level Power Supplies
2	I/O Back Panel	Rear I/O ports (see Section 4.3)
3	Fans	Two 8-cm exhaust fans
4	Expansion Slots	Six PCI-Express expansion card slots

1.5 Motherboard Layout

Below is a layout of the X11DPI-N(T) with jumper, connector and LED locations shown. See the table on the following pages for descriptions. For detailed descriptions, pinout information and jumper settings, refer to Chapter 4.

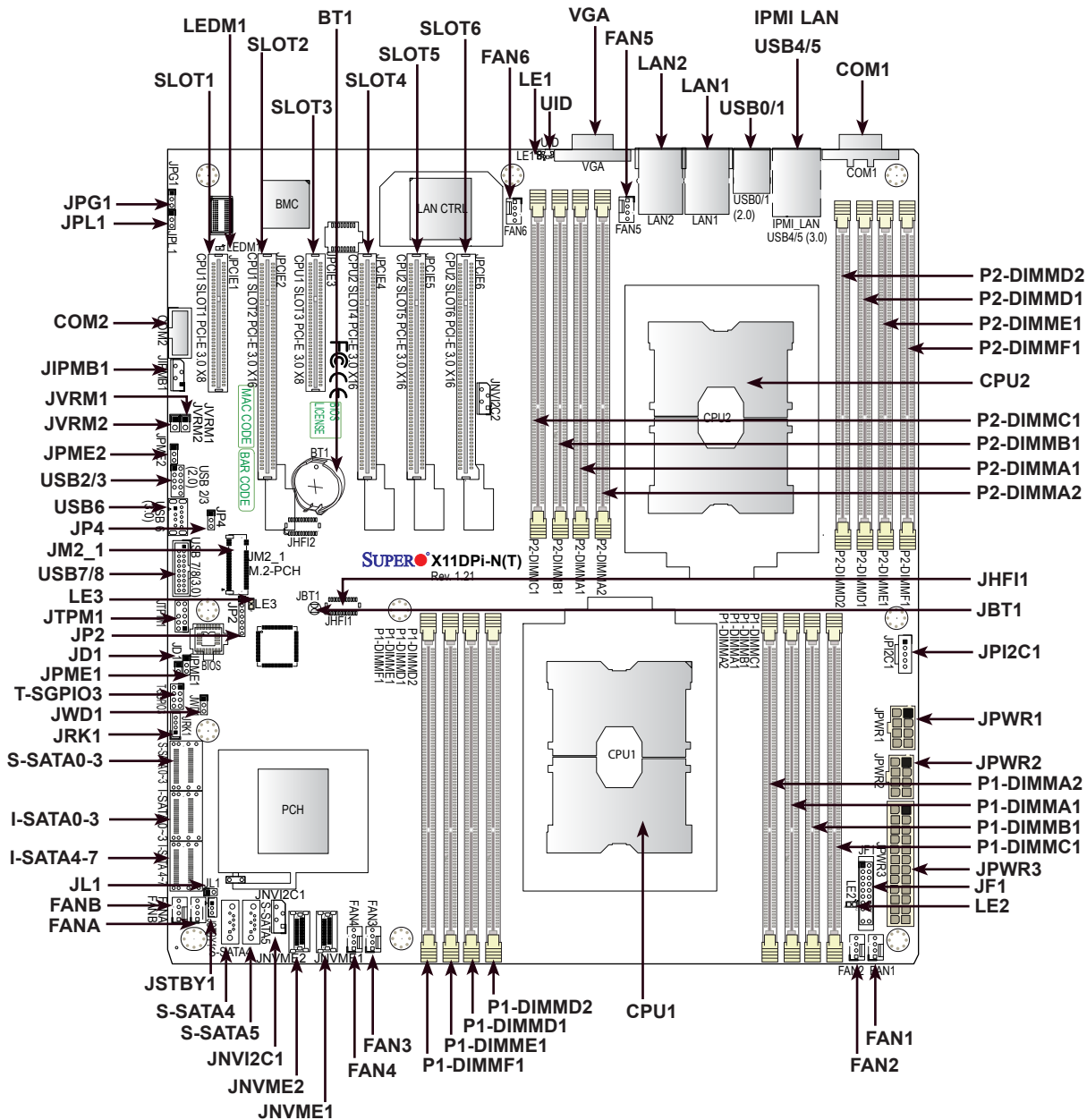

Figure 1-4. Motherboard Layout

Notes:

- " " indicates the location of pin 1.
- Jumpers/LED indicators not indicated are used for testing only.

Motherboard Jumpers, Connectors, and LEDs

Jumper	Description	Default Setting
JBT1	CMOS Clear	Open (Normal)
JPG1	Audio Enable	Pins 1-2 (Enabled)
JPL1	PHY Enable (for Ethernet support)	Pins 1-2 (Enabled)
JPME1	ME Recovery	Pins 1-2 (Normal)
JPME2	Manufacturing Mode Select	Pins 1-2 (Normal)
JVRM1/ JVRM2	VRM SMB Clock (to BMC or PCH)	Pins 1-2 (BMC, Normal)
JWD1	Watch Dog Timer Enable	Pins 1-2 (Reset to System)

Connector	Description
BT1	Onboard CMOS battery socket
COM1/COM2	Back panel COM port/COM header for front access
FAN1-6, FANA/FANB	System cooling fan headers (FAN1-FAN6, FAN A, FAN B)
IPMI_LAN	Dedicated IPMI_LAN port
I-SATA0~3, I-SATA4~7	SATA 3.0 iPass header supported by the Intel PCH
JD1	Power LED header
JF1	Front Panel Control header
JHF11/JHF12	Host Fabric Interface (HFI) sideband connection headers used for the HFI carrier cards (when the SKX-F processors are used.) (JHF11: for CPU1, JHF12: for CPU2).
JIPMB1	4-pin BMC External I ² C header (for an IPMI-supported card)
JL1	Chassis Intrusion header
JM2_1	PCIe M.2 slot
JNVI ² C1/JNVI ² C2	NVMe I ² C headers used for PCIe hot-plug SMBus clock and data connections (a proprietary NVMe add-on card and cable are required; available for a Supermicro complete system only)
JNVME1	NVMe Connector1
JNVME2	NVMe Connector2
JPI ² C1	Power Supply SMBbus I ² C header
JPWR1/JPWR2	8-pin Power Supply connectors
JPWR3	24-pin ATX main power supply connector
JRK1	Intel RAID Key headier for NVMe SSD
JSTBY1	Standby power header
JTPM1	Trusted Platform Module (TPM)/Port 80 connector
LAN1/LAN2	Gigabit LAN/10G LAN Ethernet Ports on the IO back panel (10G LAN ports on X11DPI-NTX11DPI-N(T) only)
S-SATA0-3	S-SATA 3.0 iPass header supported by the Intel SCU
S-SATA4/S-SATA5	S-SATA Ports with built-in power pins and with support of Supermicro SuperDOM (Disk On Module) devices
SLOT1/SLOT3	PCI-Express 3.0 X8 Slots supported by CPU1
SLOT2	PCI-Express 3.0 X16 Slot supported by CPU1
SLOT4/SLOT5/SLOT6	PCI-Express 3.0 X16 Slots supported by CPU2
T-SGPIO3	General Purpose Serial I/O Port
UID	Unit Identifier (UID) Switch

Connector	Description
USB0/1	Back panel USB 2.0 Ports
USB2/3	Front Accessible USB 2.0 Header
USB4/5	Back panel USB 3.0 Ports
USB6	Type A USB 3.0 Header
USB7/8	Front Accessible USB 3.0 Header
VGA	VGA Port

LED	Description	State: Status
LE1	UID (Unit Identifier) LED	Solid Blue: Unit identified
LE2	Onboard Power LED	On: Onboard power on
LE3	M.2 Active LED	On: M.2 active
LEDM1	BMC Heartbeat LED	Blinking Green: BMC normal

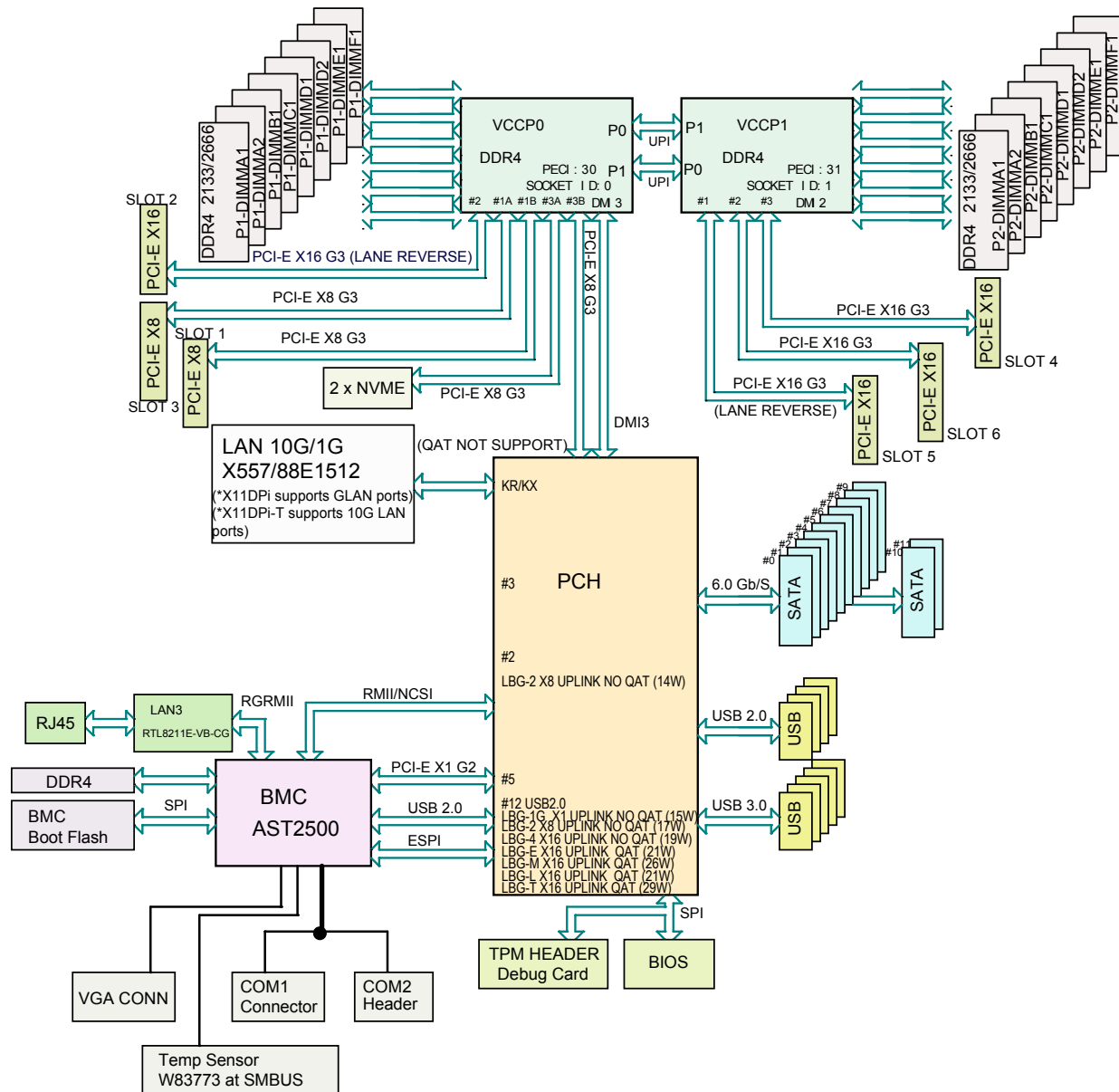

Figure 1-5. Intel C620 Series Chipset: System Block Diagram

Note: This is a general block diagram and may not exactly represent the features on your motherboard. See the System Specifications appendix for the actual specifications of your motherboard.

Chapter 2

Rack Mount Installation

2.1 Overview

This chapter provides instructions for preparing and mounting your chassis in a rack. By default, the chassis is shipped configured as a tower. The tower top cover and bottom feet must be removed to mount in a rack. Also, the control panel/drive module should be rotated 90 degrees.

Mounting rails are optional for this system. Be sure you have received the correct rail kit for your server.

2.2 Preparing for Rack Mounting

Choosing a Setup Location

- The system should be situated in a clean, dust-free area that is well ventilated. Avoid areas where heat, electrical noise and electromagnetic fields are generated.
- Leave at least 25 inches clearance in front of the rack to open the front door completely.
- Leave approximately 30 inches of clearance in the back of the rack to allow for sufficient airflow and access for servicing.
- It should be a restricted access location, such as a dedicated equipment room or a service closet.
- This product is not suitable for use with visual display workplace devices according to §2 of the German Ordinance for Work with Visual Display Units.

Rack Precautions

- Ensure that the leveling jacks on the bottom of the rack are extended to the floor so that the full weight of the rack rests on them.
- In single rack installations, stabilizers should be attached to the rack. In multiple rack installations, the racks should be coupled together.
- Always make sure the rack is stable before extending a server or other component from the rack.

- You should extend only one server or component at a time; extending two or more simultaneously may cause the rack to become unstable.
- When initially installing the server to a rack, test that the rail locking tabs engage to prevent the server from being overextended. Have a rack lift in place as a precaution in case the test fails.

Server Precautions

- Review the electrical and general safety precautions in Appendix B.
- Determine the placement of each component in the rack *before* you install the rails.
- Install the heaviest server components at the bottom of the rack first and then work your way up.
- Use a regulating uninterruptible power supply (UPS) to protect the server from power surges and voltage spikes and to keep your system operating in case of a power failure.
- Allow any drives and power supply modules to cool before touching them.
- When not servicing, always keep the front door of the rack and all covers/panels on the servers closed to maintain proper cooling.

Rack Mounting Considerations

Ambient Operating Temperature

If installed in a closed or multi-unit rack assembly, the ambient operating temperature of the rack environment may be greater than the room's ambient temperature. Therefore, consideration should be given to installing the equipment in an environment compatible with the manufacturer's maximum rated ambient temperature (TMRA).

Airflow

Equipment should be mounted into a rack so that the amount of airflow required for safe operation is not compromised.

Mechanical Loading

Equipment should be mounted into a rack so that a hazardous condition does not arise due to uneven mechanical loading.

Circuit Overloading

Consideration should be given to the connection of the equipment to the power supply circuitry and the effect that any possible overloading of circuits might have on overcurrent protection and power supply wiring. Appropriate consideration of equipment nameplate ratings should be used when addressing this concern.

Reliable Ground

A reliable ground must be maintained at all times. To ensure this, the rack itself should be grounded. Particular attention should be given to power supply connections other than the direct connections to the branch circuit (i.e. the use of power strips, etc.).



To prevent bodily injury when mounting or servicing this unit in a rack, you must take special precautions to ensure that the system remains stable. The following guidelines are provided to ensure your safety:

- This unit should be mounted at the bottom of the rack if it is the only unit in the rack.
- When mounting this unit in a partially filled rack, load the rack from the bottom to the top with the heaviest component at the bottom of the rack.
- If the rack is provided with stabilizing devices, install the stabilizers before mounting or servicing the unit in the rack.
- Slide rail mounted equipment is not to be used as a shelf or a work space.

2.3 Chassis Preparation

The chassis is shipped with the tower top cover and feet installed. Both must be removed for before installing the rails.

Removing the Tower Top Cover

1. Locate the chassis cover lock (blue lever) at the rear of the chassis cover.
2. Slide the chassis cover lock to the right and push chassis cover forward.
3. Lift the chassis top cover off the chassis.

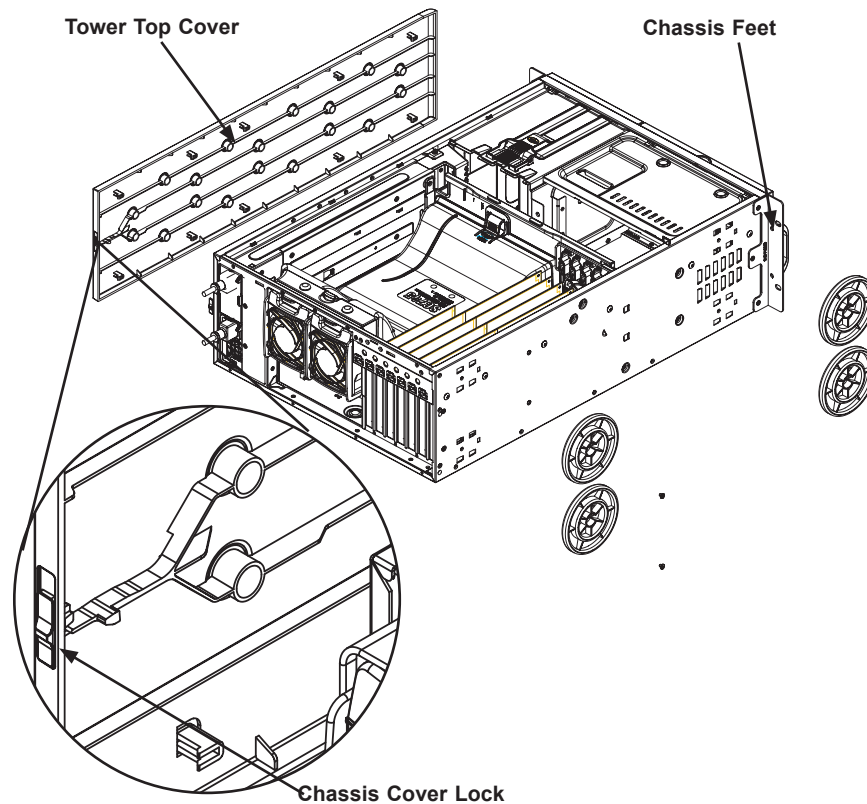

Figure 2-1. Remove Feet and Chassis Top Cover

Removing the Chassis Feet

1. Place the chassis on its side.
2. Remove the screw holding a chassis foot in place.
3. The foot lock is a tab located in the center of the foot. It prevents the foot from sliding. Using a flat head screwdriver, gently lift the foot lock upward and slide the foot toward the rear of the chassis.

2.4 Installing the Rails

There are a variety of rack units on the market, which may require a slightly different assembly procedure. Do not use a two post "telco" type rack. This rail set fits a rack between 26" and 35.9" deep.

The following is a basic guideline for installing the system into a rack with the rack mounting hardware provided. You should also refer to the installation instructions that came with the specific rack you are using.

Identifying the Rails

The optional rackmount kit includes two rack rail assemblies, one for each side. Each of these assemblies consist of several sections: an inner fixed rail that secures to the chassis, an outer rack rail that secures to the rack, a middle rail that slides within the outer rail, and two brackets that attach the outer rail to the rack. The brackets are specific to the left and right side, and front and back, and labeled.

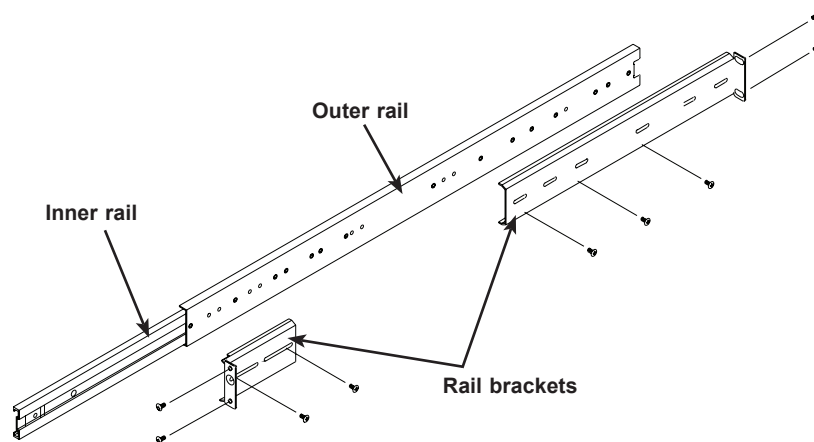

Figure 2-2. Identifying the Sections of the Rack Rails

Releasing the Inner Rails

The inner rails must be removed from the outer rails to install onto the chassis. To remove the inner rail, pull it out as far as possible until it clicks to a stop. Depress the locking lever on the inner rail next to the middle rail to pull the inner rail completely out.

Installing the Inner Rails

Identify the left and right inner rails.

1. Attach the handles to the front sides of the chassis with three screws each.
2. Position the inner rails along the side of the chassis making sure the screw holes line up.
3. Screw the rail securely to the side of the chassis.

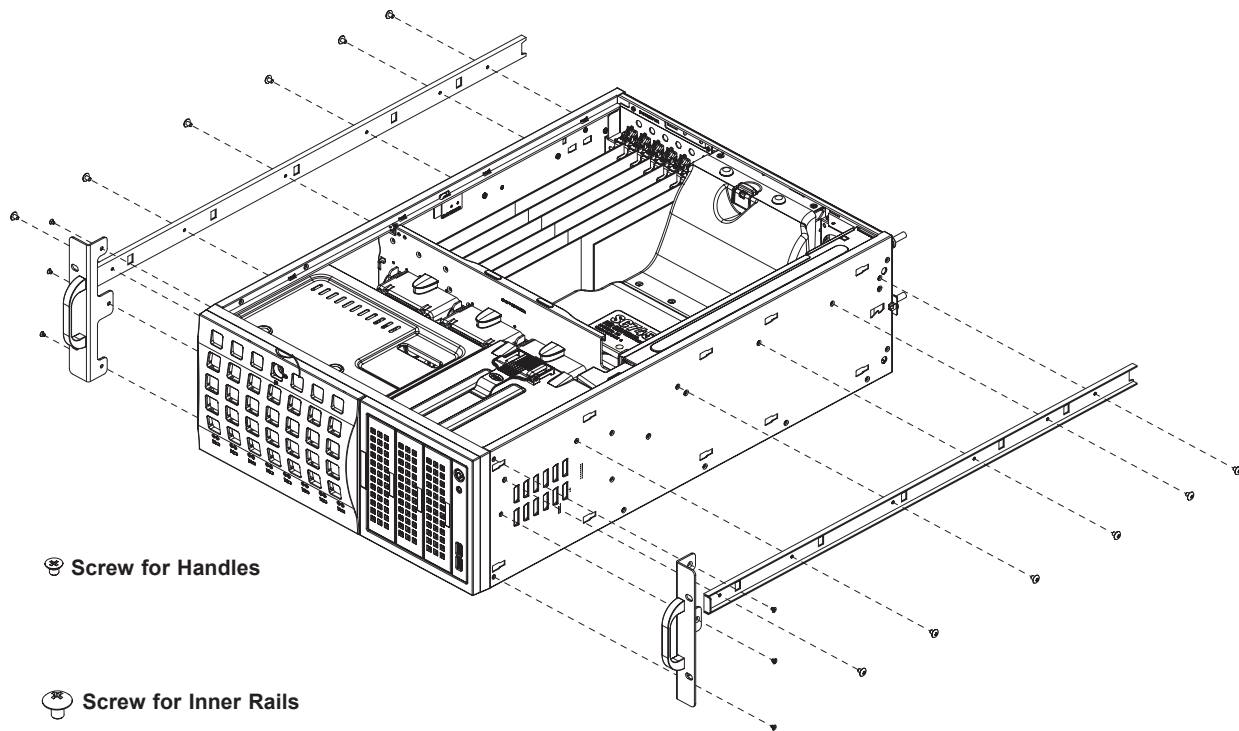

Figure 2-3. Installing the Chassis Rails



Warning: Do not pick up the server with the front handles. They are designed to pull the system from a rack only.

Assembling and Installing the Outer Rails

Each outer rail comes in three sections that require assembly before mounting onto the rack.

1. Find the outer rail mounting brackets in the chassis accessory box.

- A pair of long brackets for the rear of each rail
- A pair of short brackets for the front of each rail

Note that the brackets are labeled as to front, rear, and up. They are specific for the left and right rails.

2. Secure the front (short) bracket onto the outer rail with M5 screws.

3. Mount the rear (long) bracket onto the outer rail at the approximate position to fit your rack. Use two or three M5 screws into holes that are convenient. Leave the screws just loose enough that the bracket can slide.

4. Install the outer rail assembly onto your rack. Adjust the outer rail to the exact depth of the rack by sliding the rear bracket. Then use screws and fasteners to secure the outer rail to the front and rear rack posts.

5. Further tighten the screws holding the rear bracket to the rail.

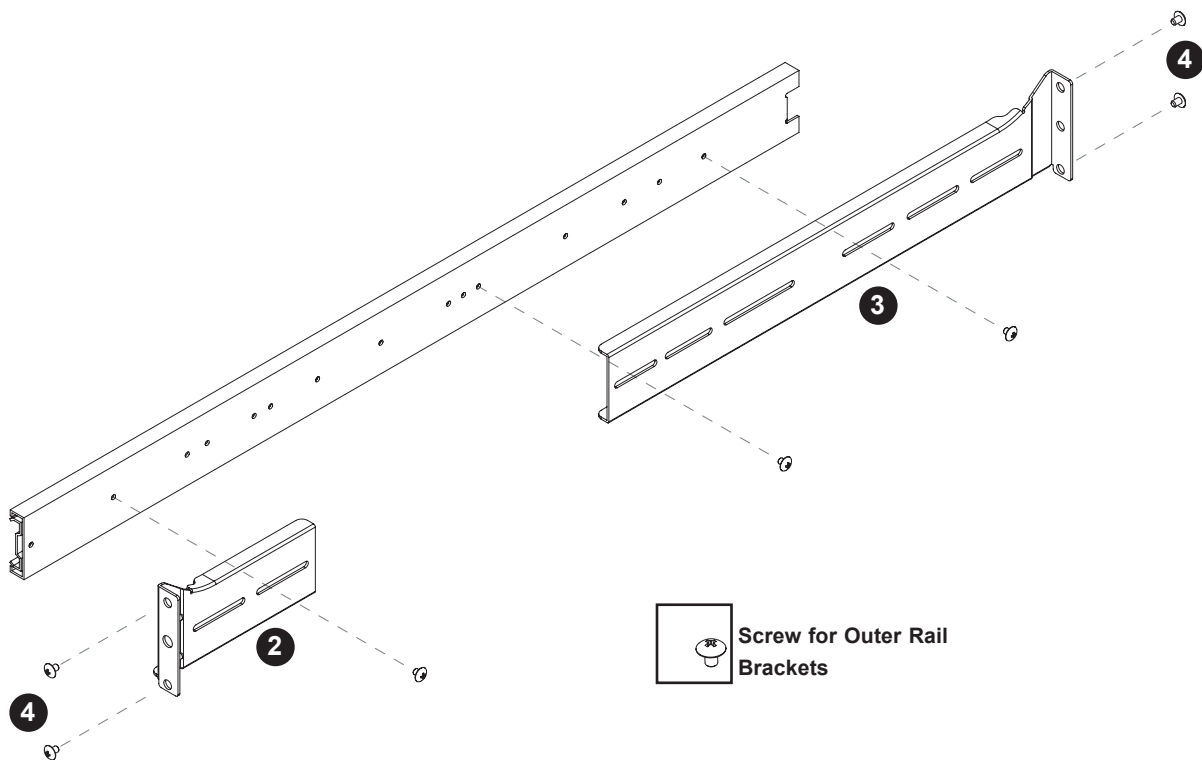

Figure 2-4. Assembling the Outer Rails

2.5 Installing the Server into the Rack

After attaching rails to both the chassis and the rack, slide the server into the rack.

1. Pull the middle rail out of the front of the outer rail and make sure that the ball bearing shuttle is locked at the front of the middle rail.
2. Align the rear of the inner (chassis) rails with the front of the outer (rack) rails and slide the inner rails into the outer rails until the server is completely in the rack.
3. Insert and tighten the thumbscrews that hold the front of the server to the rack.

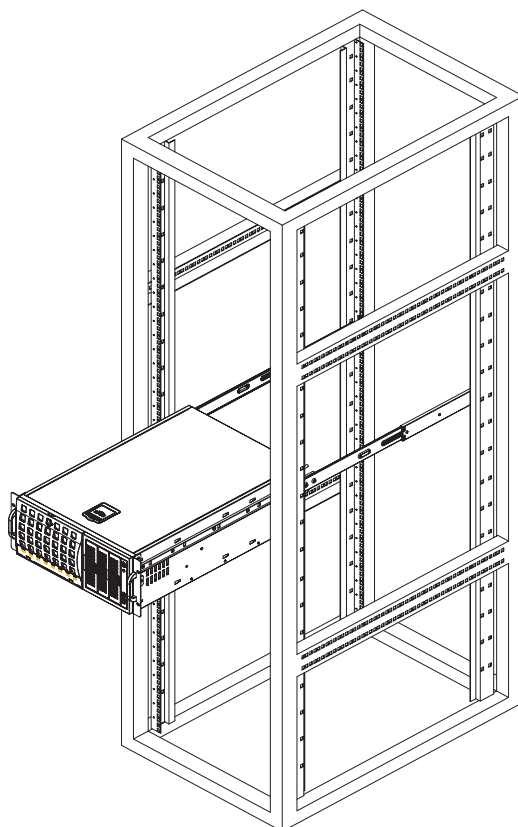

Figure 2-5. Installing the Server into a Rack

Note: Figure is for illustrative purposes only. Always install servers to the bottom of a rack first.



Warning: Stability hazard. The rack stabilizing mechanism must be in place, or the rack must be bolted to the floor before you slide the unit out for servicing. Failure to stabilize the rack can cause the rack to tip over.



When initially installing the server to a rack, test that the rail locking tabs engage to prevent the server from being overextended. Have a rack lift in place as a precaution in case the test fails.

Removing the Chassis from the Rack

Caution! It is dangerous for a single person to off-load the heavy chassis from the rack without assistance. Be sure to have sufficient assistance supporting the chassis when removing it from the rack. Use a lift.

1. Pull the chassis forward out the front of the rack until it stops.
2. Find the release lever on each side of the chassis on the inner rails. Release the chassis by simultaneously and lifting the left lever and pushing down the right lever. Continue to pull the chassis out of the rack.



Warning: In any instance of pulling the system from the rack, always use a rack lift and follow all associated safety precautions.



Slide rail mounted equipment is not to be used as a shelf or a work space.

2.6 Control Panel Orientation

The server can be configured for either tower or server rack orientation. It is shipped in tower mode and can be immediately used as desktop server. To use it in a rack, rotate the module that contains the control panel and the three drive trays (1 in Figure 2-6) 90 degrees.

Note that two of the 5.25" drives may be replaced by a *mobile rack* containing eight 2.5" storage drives.

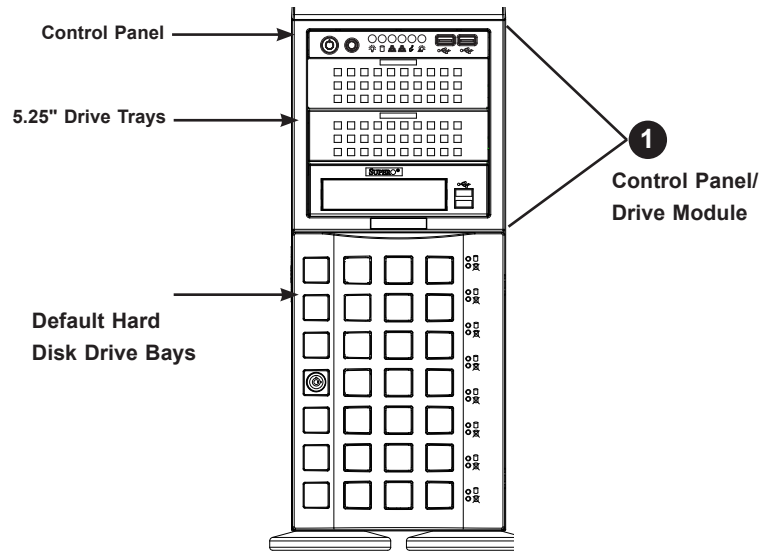

Figure 2-6. Chassis in Tower Mode (Default Configuration)

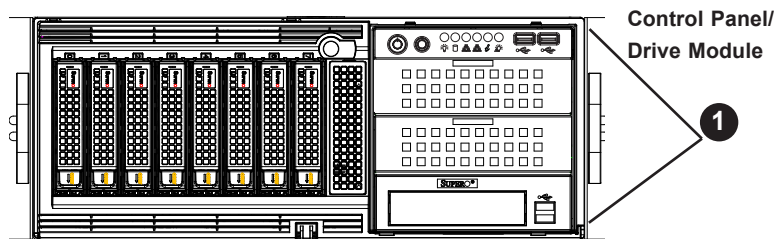

Figure 2-7. Chassis in Rack Mount Mode

Rotating the Control Panel/Drive Module for Rack Mounting

1. Power down the system as described in section 3.1 and open the chassis cover.
2. Disconnect any cables from the back of the Control Panel/Drive Module.
3. Push the module release lever to unlock the module.

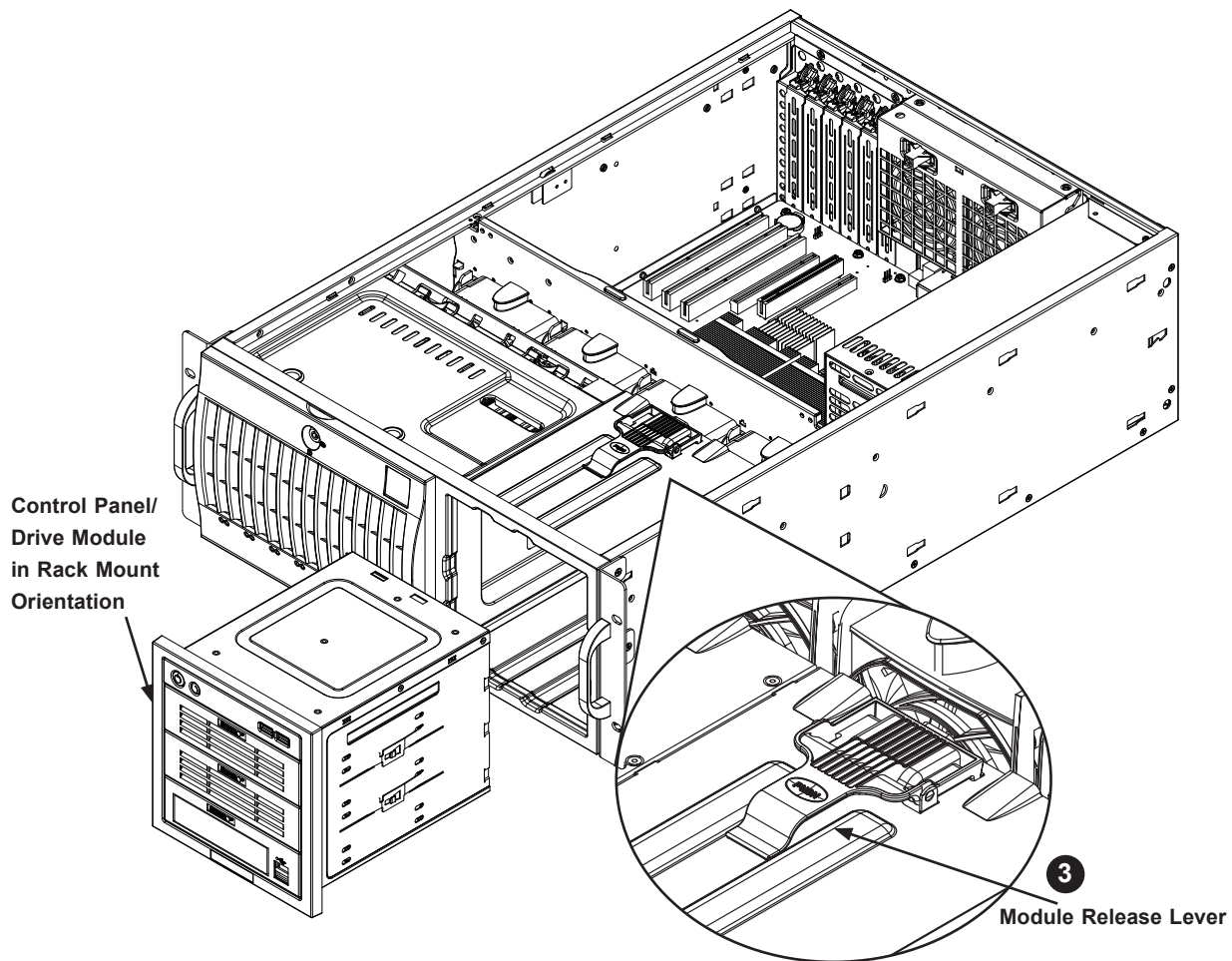

Figure 2-8. Rotating the Control Panel/Drive Module

4. Grasp the edges of the module and pull it from the chassis.
5. Rotate the module 90 degrees so that the control panel is on top.
6. Reinsert the module into the chassis and reconnect the cables.

Caution: Use caution when working around the backplane. Do not touch the module backplane with any metal objects and make sure no ribbon cables touch the backplane or obstruct the holes, which aid in proper airflow.

Chapter 3

Maintenance and Component Installation

This chapter provides instructions on installing and replacing main system components. To prevent compatibility issues, only use components that match the specifications and/or part numbers given.

Installation or replacement of most components require that power first be removed from the system. Please follow the procedures given in each section.

3.1 Removing Power

Use the following procedure to ensure that power has been removed from the system. This step is necessary when removing or installing non-hot-swap components.

1. Use the operating system to power down the system.
2. After the system has completely shut down, disconnect both the AC power cords from the power strip or outlet.
3. Disconnect the power cords from both the power supply modules.

3.2 Accessing the System

The chassis offers a removable side cover (top, if rack mounted) which allows access to the internal components.

Removing the Side Cover

1. Locate the latch on the cover, depress where it says "push," then lift the latch to release the cover.
2. Slide the cover to the rear and off.

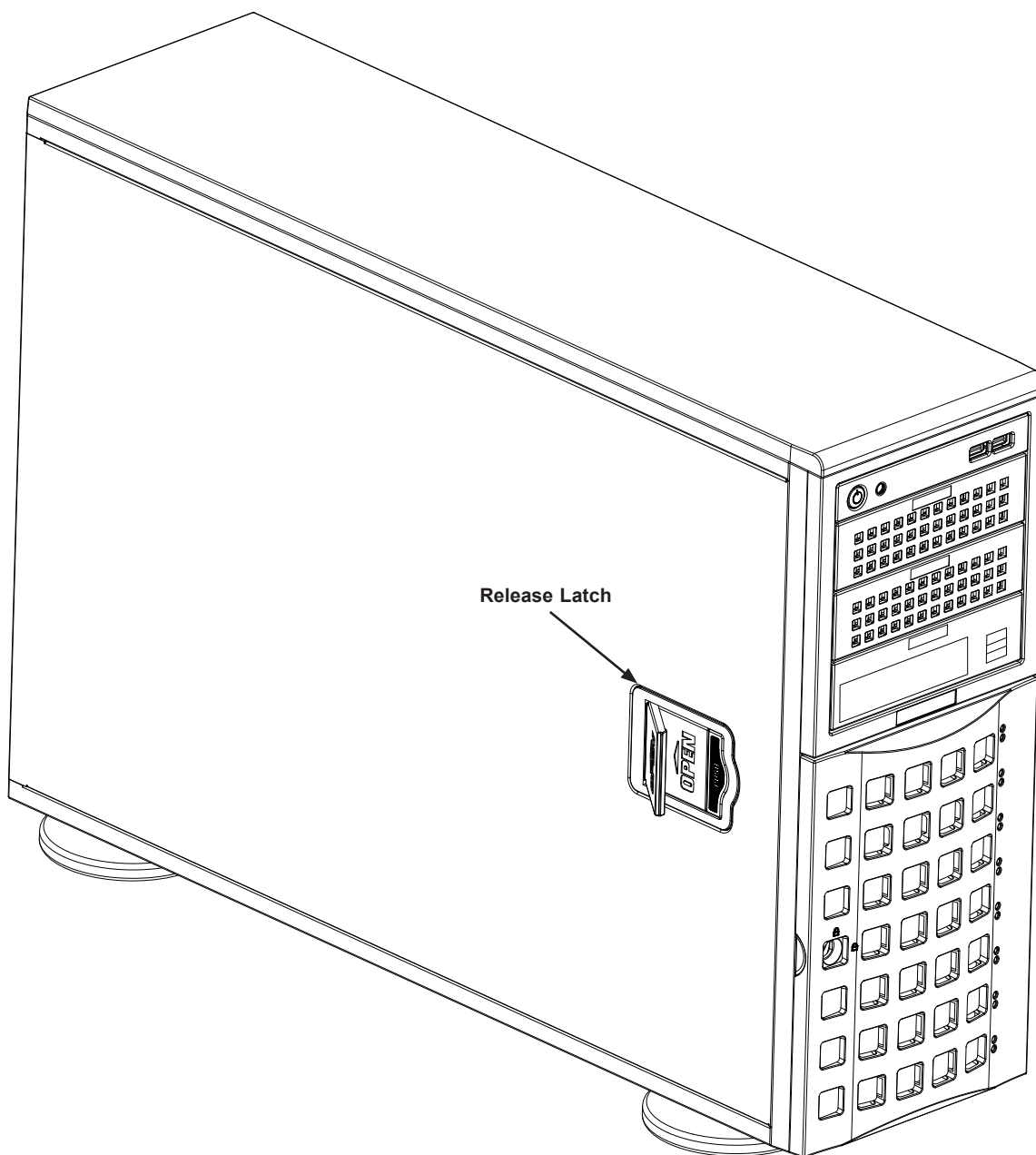

Figure 3-1. Removing the Chassis Cover

3.3 Motherboard Components

Processor and Heatsink Installation

Follow the procedures in this section to install a processor (CPU) and heatsink onto the motherboard. Improper CPU installation or socket misalignment can cause serious damage to the CPU or motherboard which may require RMA repairs.

Notes:

- All power should be off, as described in Section 3.1, before installing the processors.
- When handling the processor package, avoid placing direct pressure on the label area of the CPU or socket.
- The processor and heatsink should be assembled together first to form the Processor Heatsink Module (PHM), and then install the entire PHM into the CPU socket.
- When receiving a motherboard without a processor pre-installed, make sure that the plastic CPU socket cap is in place and none of the socket pins are bent; otherwise, contact your retailer immediately.
- Refer to the Supermicro website for updates on CPU support.

The Xeon Scalable Processor

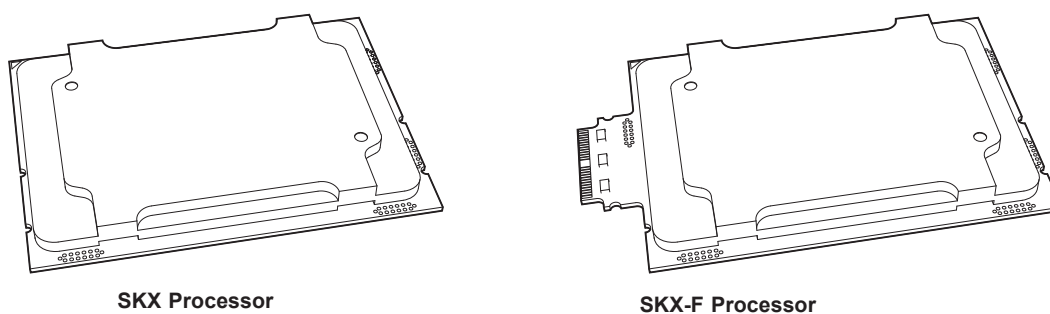

Figure 3-2. Xeon Scalable Processors

Note: The 7049P-TR(T) server supports only one -F model processor and it must be CPU1..

Note: All graphics, drawings, and pictures shown in this manual are for illustration only. The components that came with your server may or may not look exactly the same as those shown in this manual.

Overview of the Processor Socket Assembly

The processor socket assembly contains 1) the Intel SKX(-F) CPU, 2) the narrow processor clip, 3) the dust cover, and 4) the CPU socket.

1. SKX (-F) CPU

(for the non-F model)

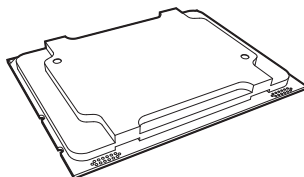

2. Narrow processor clip (the plastic processor carrier used for the CPU)

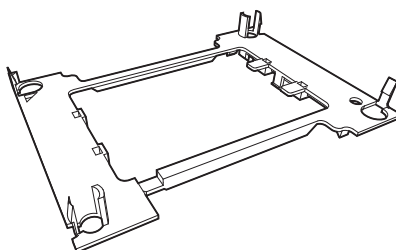

3. Dust Cover

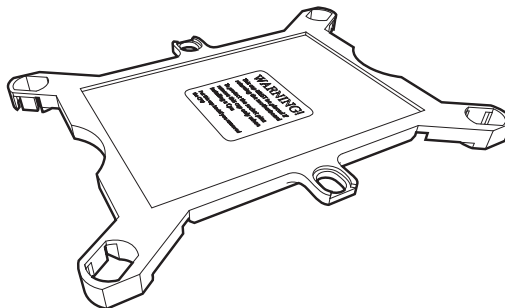

4. CPU Socket

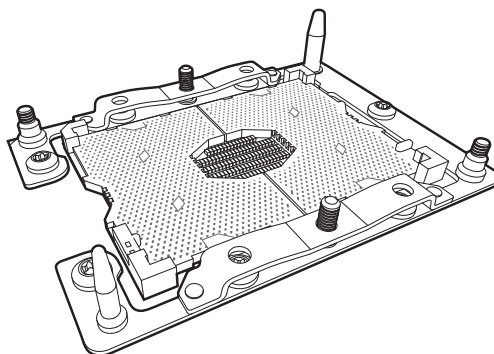

Note: Be sure to cover the CPU socket with the dust cover when the CPU is not installed.

Heatsinks

The 7049P-TR(T) server uses this heatsink design for each processor.

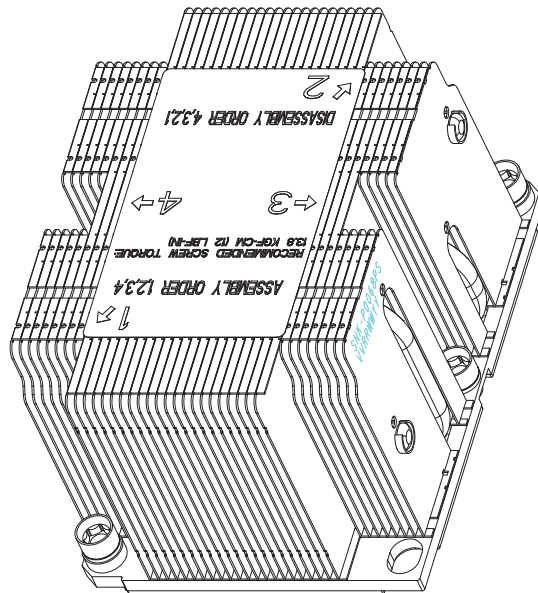
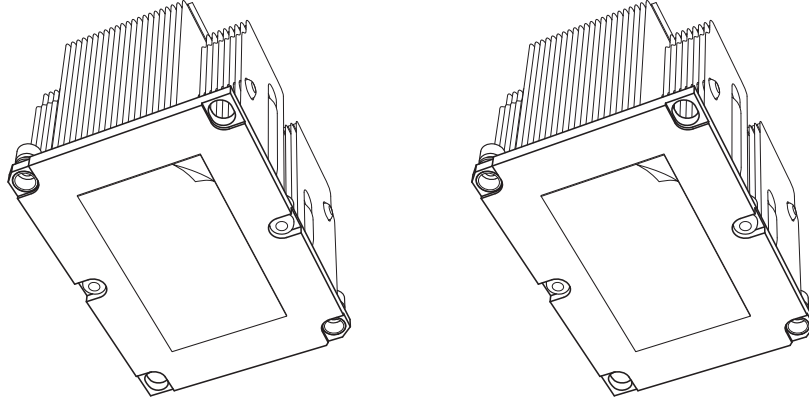

Figure 3-3. Heatsink SNK-P0068PS

Overview of the Processor Heatsink Module (PHM)

The Processor Heatsink Module (PHM) contains 1) a heatsink, 2) a narrow processor clip, and 3) the SKX(-F) processor.

1. Heatsink



2. Narrow processor clip

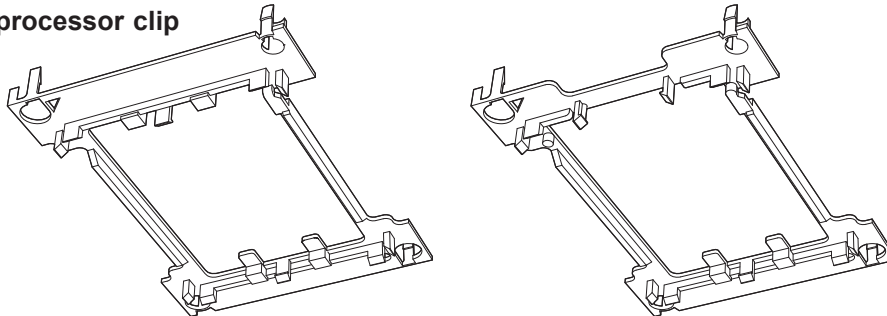

3. SKX(-F) Processor

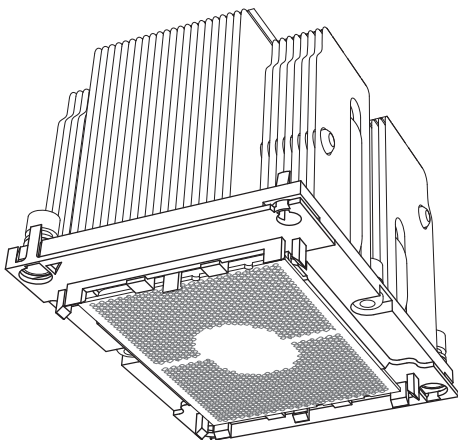
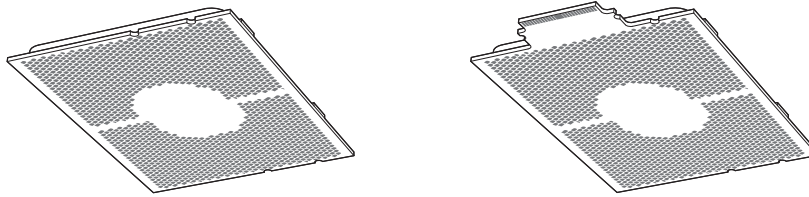

(Bottom View for a non-F Model)

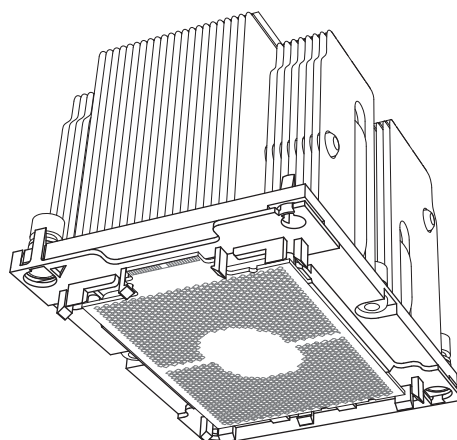

(Bottom View for an F Model; only CPU1)

Assembling the Processor Package

Attach the processor to the narrow processor clip to create the processor package.

Caution: Be careful handling the CPU. Do not touch the underside. Wear ESD gloves.

1. On the top corner of the CPU, locate pin 1 (A), marked by a triangle. Also, locate notch B and notch C (and notch D for -F models) on the CPU as shown below.
2. On the top of the narrow processor clip, locate the corner marked by a triangle as the position for pin 1. Also locate notch B and notch C (and D for -F models) on the processor clip.
3. Align pin 1 of the CPU with its proper position on the processor clip and carefully insert the CPU into the processor clip. Slide notch B of the CPU into tab B of the processor clip, and slide notch C of the CPU into tab C of the processor clip (and D for -F models) until the processor clip tabs snap onto the CPU.
4. Examine all corners to ensure that the CPU is properly seated and secure on the processor clip.

The processor package assembly is created.

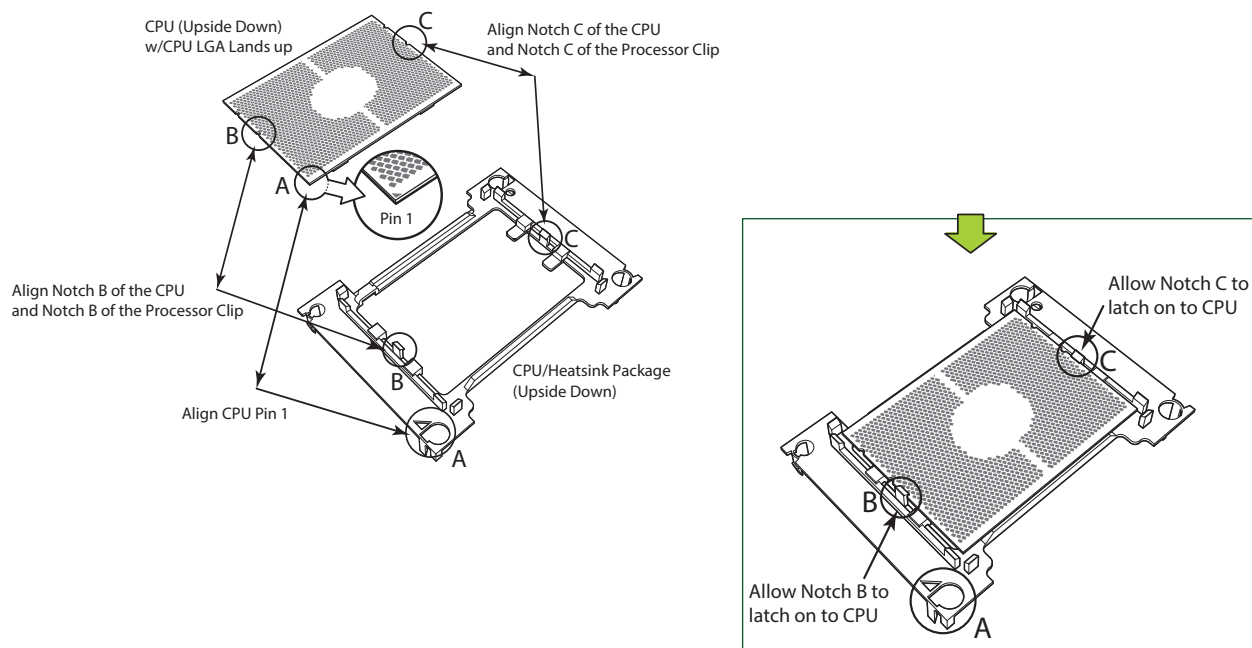

Processor Package Assembly for the non-F Model Processors (with CPU mounted on the Processor Clip)

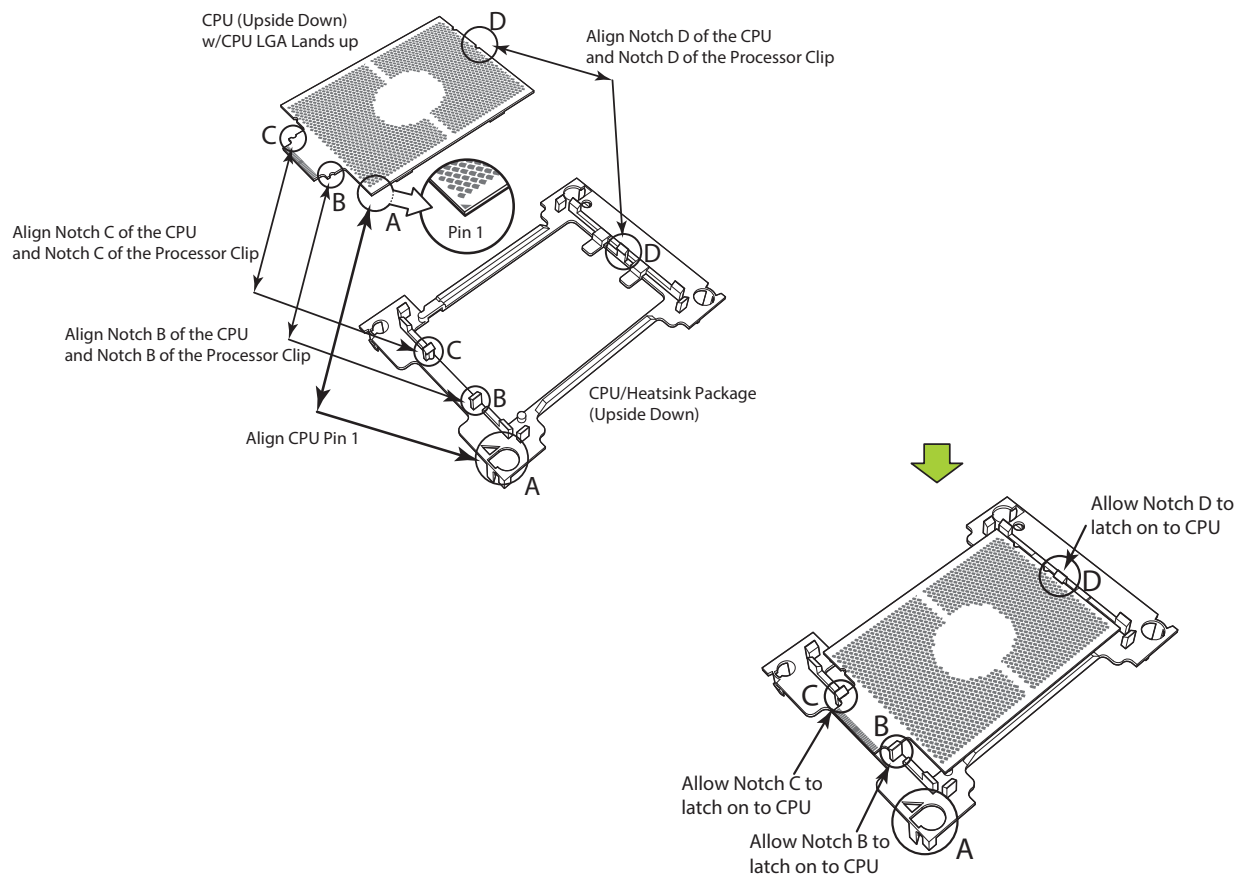

Processor Package Assembly for the -F Model Processors
(with CPU mounted on the Processor Clip)

Note: For 7049P-TR(T), the -F model processor is supported only as CPU1.

Assembling the Processor Heatsink Module (PHM)

After creating the processor package assembly, mount it onto the heatsink to create the processor heatsink module (PHM).

1. Locate "1" on the heatsink label and the corner next to it. With your index finger pressing against the screw at this corner, turn the heatsink upside down with the thermal grease side facing up.
2. Remove the protective thermal film if present. If this is a new heatsink, the necessary thermal grease has been pre-applied in the factory. If the heatsink is not new, apply the proper amount of the thermal grease.
3. Holding the processor package assembly by the edge, locate the hollow triangle at the corner ("a" in the drawing below), and note a hole and plastic mounting clips next to the triangle. Also locate another set of mounting clips and a hole at the diagonal corner of the of the processor package assembly ("b" in the drawing).
4. With the underside of heatsink and the underside of the processor package assembly facing up, align the corner on the heatsink ("A" in the drawing) against the mounting clips next to the hollow triangle ("a") on the processor package assembly.
5. Also align the corner ("B") at the diagonal side of the heatsink with the corresponding clips on the processor package assembly ("b").
6. Once aligned, press the processor package assembly onto the heatsink until the mounting clips (at a, b, c, and d) snap into place.

The processor heatsink module (PHM) is created.

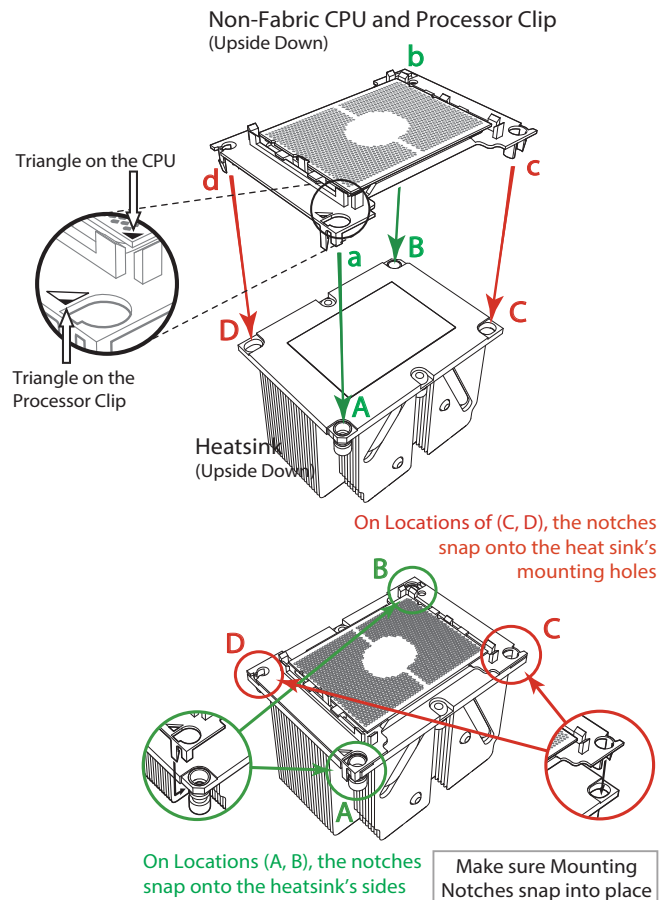

Assembling the Processor Heatsink Module

Preparing the CPU Socket for Installation

This motherboard comes with the CPU socket assembled in the factory. It includes a dust cover, a socket bracket, the CPU socket (P0), and a back plate.

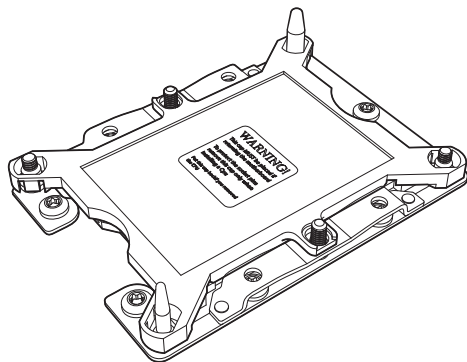

CPU Socket with Dust Cover On

Removing the Dust Cover from the CPU Socket

Remove the dust cover from the CPU socket, exposing the socket pins as shown below.

Caution: Do not touch the socket pins.

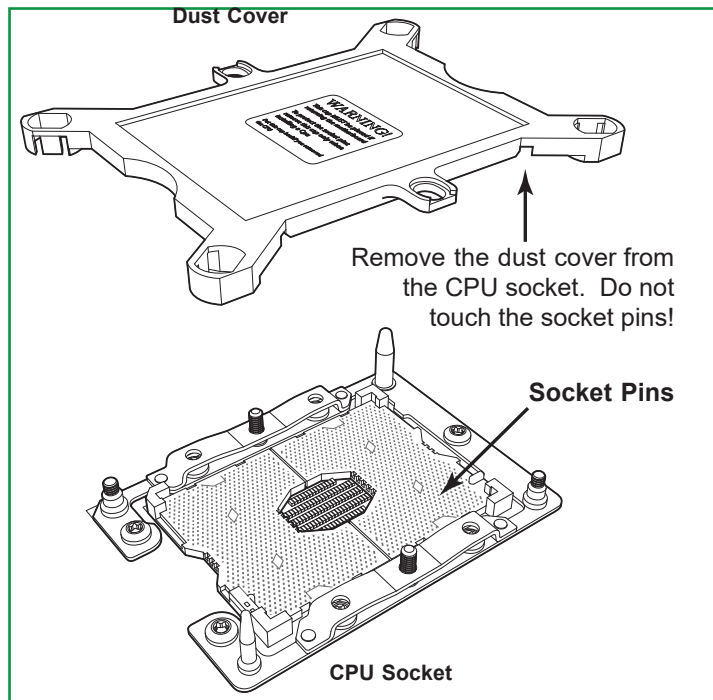

Removing the Socket Dust Cover

Installing the Processor Heatsink Module (PHM)

1. Locate the triangle (pin 1) on the CPU socket, and locate the triangle (pin 1) at the corner of the PHM that is closest to "1." (If you have difficulty locating pin 1, turn the PHM upside down. On the underside of the CPU, you can see the hollow triangle located next to a screw at the corner. Turn the PHM right side up, and you will see a triangle marked on the processor clip at the same corner as hollow triangle.)
2. Align pin 1 corner of the PHM over pin 1 corner on the CPU socket.
3. Align the two holes at diagonal corners of the PHM onto the two guide posts on the socket bracket and carefully drop the PHM onto the socket.
4. Use a T30 Torx-bit screwdriver to install four screws into the mounting holes on the socket to securely attach the PHM onto the motherboard in the sequence of 1, 2, 3, and 4, as marked on the heatsink label. Gradually tighten each to assure even pressure.

Note: Use only 12 foot-pounds of torque when tightening the screws to avoid damaging the processor or the socket.

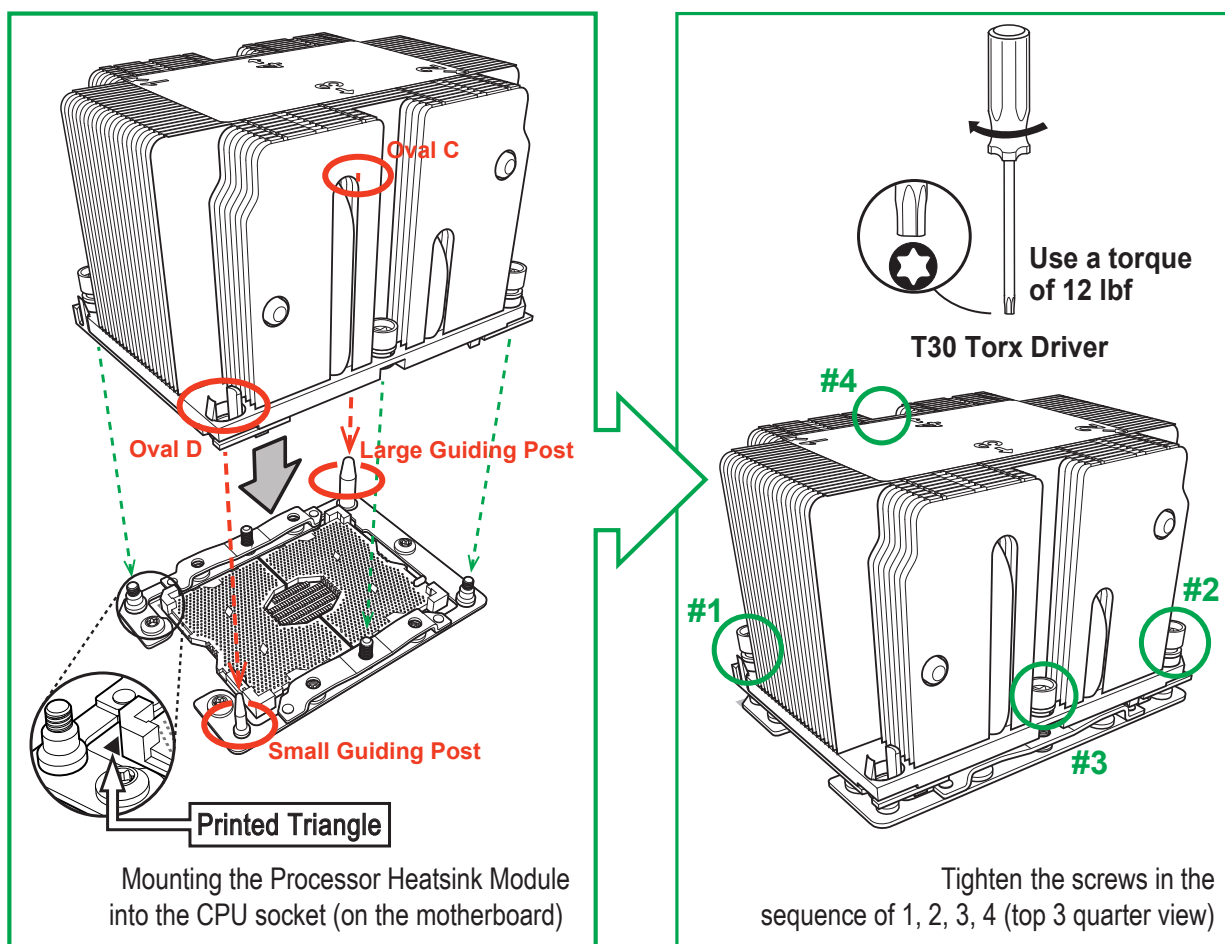

Installing the Processor Heatsink Module

Connecting an HFI Carrier Card

A host fabric interface (HFI) carrier card can be connected the JHFI sideband header and to an SKX-F processor. Two HFI headers are located on the X11DPI-N(T) motherboard. JHFI1 is used for CPU 1, and JHFI2 is for CPU2. (For more information on the JHFI1/JHFI2 headers, see Chapter 4.) **Note:** The 7049P-TR(T) server supports only one -F model processor, and thus only one HFI connection.

Installation Instructions

1. Install the HFI carrier card to an appropriate PCIe slot.
2. Locate the JHFI1 header on the motherboard. If CPU2 is used, use the JHFI2 header on the motherboard.
3. Connect the HFI connector on the HFI sideband cable to the JHFI1 header.
4. Connect the other end of the HFI cable to the connector (marked **A**) on the HFI card as shown below.
5. Connect the the plug (marked 5) on one end of the IFP54B cable to the connector (marked **B**) on the HFI card as shown below.
6. Connect the other end of IFP54B cable to the SKX-F CPU as shown below.

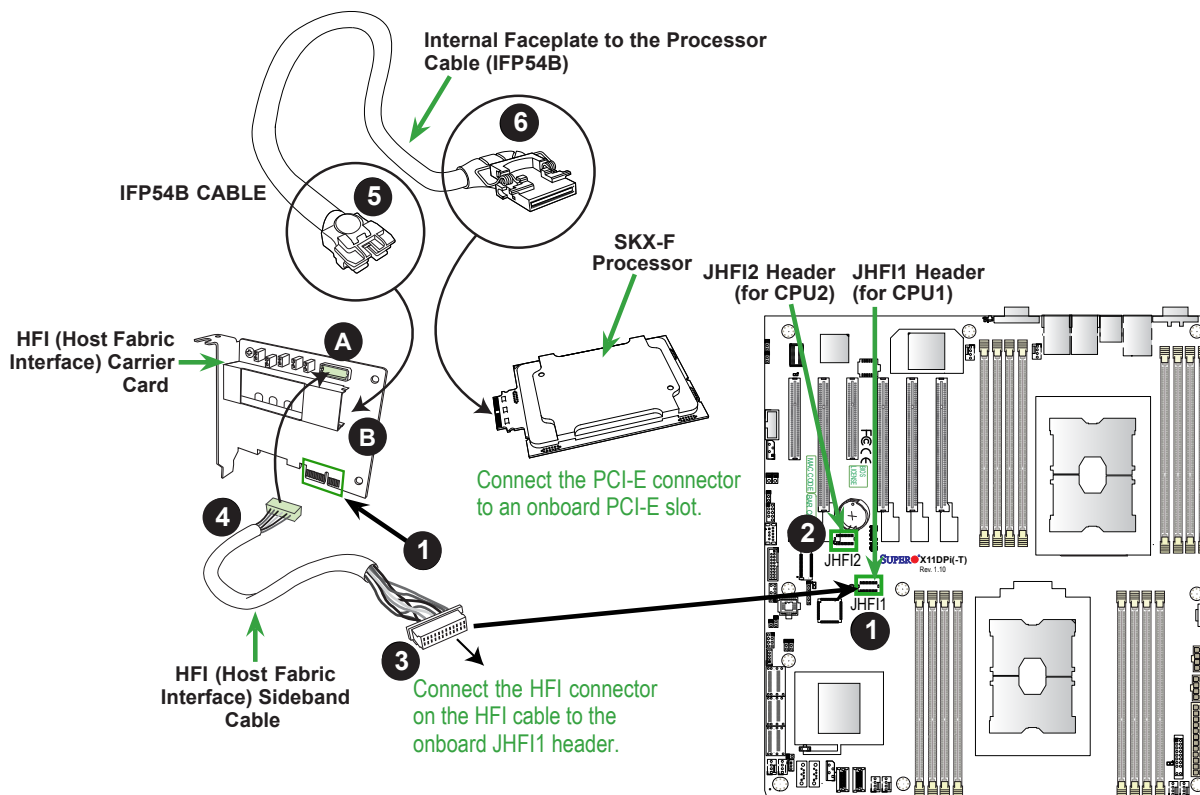

Connecting the HFI Carrier Card

Removing the Processor Heatsink Module from the Motherboard

Before removing the processor heatsink module (PHM), power down as described in Section 3.1.

1. Using a T30 Torx-bit screwdriver, loosen and remove the screws on the PHM from the socket, starting with the screw marked #4, in the sequence of 4, 3, 2, 1.
2. Pull up the PHM while releasing the small snap tabs on two corners of the socket.

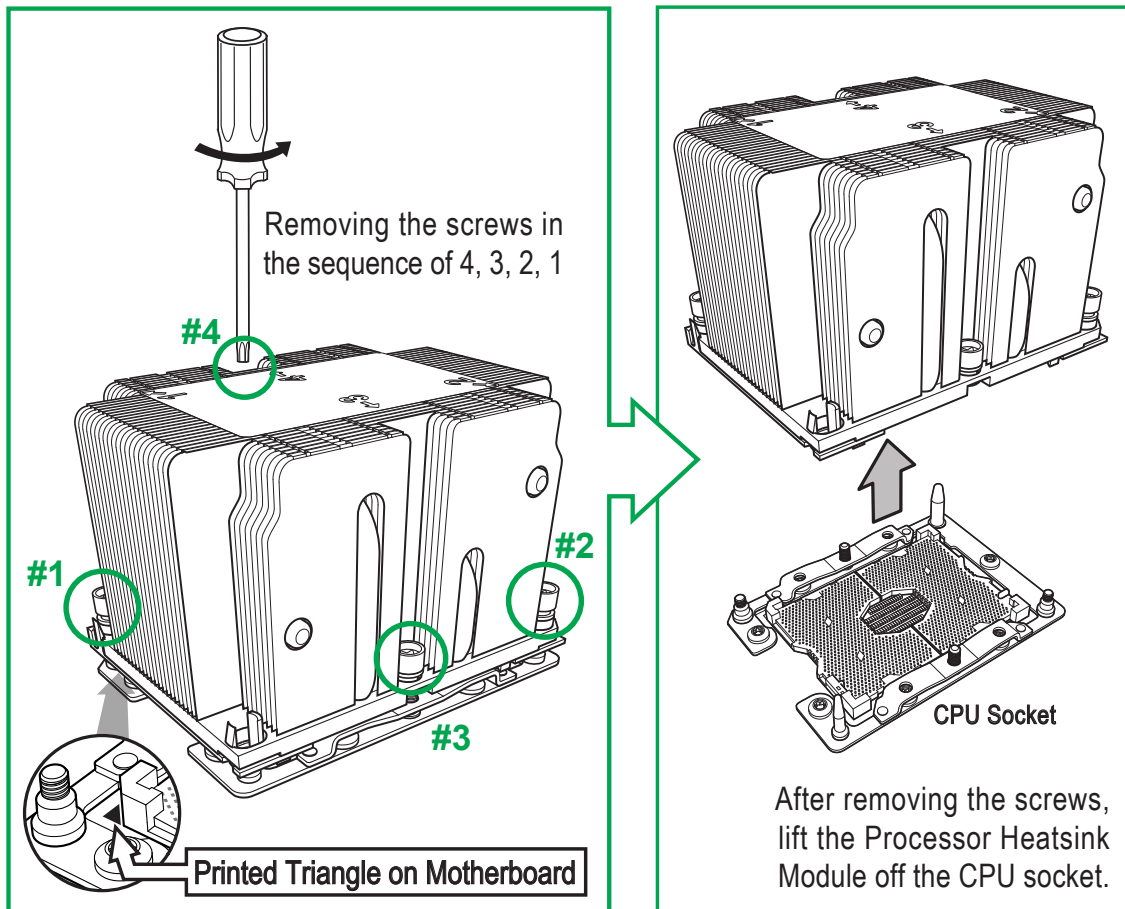

Removing the Processor Heatsink Module

Memory

Memory Support

The 7049P-TR(T) supports up to 2TB of 3DS Load Reduced DIMM (3DS LRDIMM), Load Reduced DIMM (LRDIMM), 3DS Registered DIMM (3DS RDIMM), Registered DIMM (RDIMM), Non-Volatile DIMM (NV-DIMM) DDR4 (288-pin) ECC 2666/2400/2133 MHz memory modules in 16 slots. Memory speed is dependent on the processor model.

Populating these DIMM modules with a pair of memory modules of the same type and size will result in interleaved memory, which will improve memory performance. Using unbalanced memory topology, such as populating two DIMMs in one channel while populating one DIMM in another channel on the same motherboard will result in reduced memory performance.

Check the Supermicro website for possible updates to memory support.

DIMM Module Population Configuration

For optimal memory performance, follow the specifications below when populating memory.

DDR4 Memory Support for the Intel Intel 81xx/61xx/51xx/41xx/31xx series Processor Platform						
Type	Ranks Per DIMM and Data Width	DIMM Capacity (GB)		Speed (MT/s); Voltage (V); Slots per Channel (SPC) and DIMMs per Channel (DPC)		
				2 Slots per Channel		
				1DPC (1-DIMM per Channel)	2DPC (2-DIMM per Channel)	
		4 Gb	8 Gb	1.2 V	1.2 V	
RDIMM	SRx4	8 GB	16 GB	2666	2666	
RDIMM	SRx8	4 GB	8 GB	2666	2666	
RDIMM	DRx8	8 GB	16 GB	2666	2666	
RDIMM	DRx4	16 GB	32 GB	2666	2666	
RDIMM 3Ds	QRX4	N/A	2H-64GB	2666	2666	
	8RX4	N/A	4H-128GB	2666	2666	
LRDIMM	QRx4	32 GB	64 GB	2666	2666	
LRDIMM 3Ds	QRX4	N/A	2H-64GB	2666	2666	
	8RX4	N/A	4H-128 GB	2666	2666	

Key Parameters for DIMM Configurations	
Parameters	Possible Values
Number of Channels	1, 2, 3, 4, 5, or 6
Number of DIMMs per Channel	1DPC (1 DIMM Per Channel) or 2DPC (2 DIMMs Per Channel)
DIMM Type	RDIMM (w/ECC), LRDIMM, 3DS-LRDIMM
DIMM Construction	<ul style="list-style-type: none"> - non-3DS RDIMM Raw Cards: A/B (2RX4), C (1RX4), D (1RX8), E (2RX8) - 3DS RDIMM Raw Cards: A/B (4RX4) - non-3DS LRDIMM Raw Cards: D/E (4RX4) - 3DS LRDIMM Raw Cards: A/B (8RX4)

General Population Requirements
DIMM Mixing Rules
<ul style="list-style-type: none"> - All DIMMs must be DDR4. - X4 and X8 DIMMs can be mixed in the same channel. - Mixing of LRDIMMs and RDIMMs is not allowed in the same channel, across different channels, and across different sockets. - Mixing of non-3DS and 3DS LRDIMM is not allowed in the same channel, across different channels, and across different sockets.

Mixing of DIMM Types within a Channel			
DIMM Types	RDIMM	LRDIMM	3DS LRDIMM
RDIMM	Allowed	Not Allowed	Not Allowed
LRDIMM	Not Allowed	Allowed	Not Allowed
3DS LRDIMM	Not Allowed	NotAllowed	Allowed

Install Procedure

The DIMM slots must be populated in the following order: P1-DIMMA1, P1-DIMMD1, P1-DIMMB1, P1-DIMME1, and P1-DIMMC1, P1-DIMMF1. The blue slots must be populated first.

Caution: Exercise caution when installing or removing memory modules to prevent damage to the DIMMs or slots.

Installing Memory

1. Remove power from the system as described in Section 3.1.

2. Starting with P1-DIMMA1, push the release tabs outwards on both ends of the DIMM slot to unlock it.

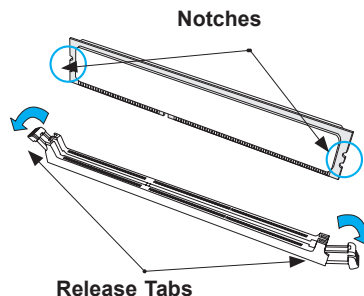

3. Align the key of the DIMM with the receptive point on the memory slot and with your thumbs on both ends of the module, press it straight down into the slot until the module snaps into place.

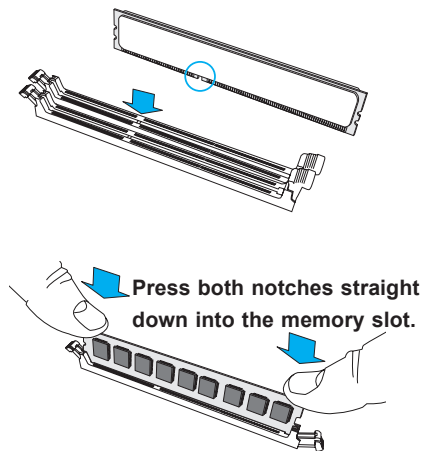

4. Press the release tabs to the locked position to secure the DIMM module into the slot.

To remove a DIMM module, unlock the release tabs then pull the module from the slot.

PCIe M.2 Slot

The motherboard has one M.2 slot. M.2 was formerly Next Generation Form Factor (NGFF) and serves to replace mini-PCIe. M.2 allows for a variety of card sizes, increased functionality, and spatial efficiency. The M.2 socket on the motherboard supports PCIe 3.0 X4 (32 Gb/s) SSD cards in the 2280 and 22110 form factors.

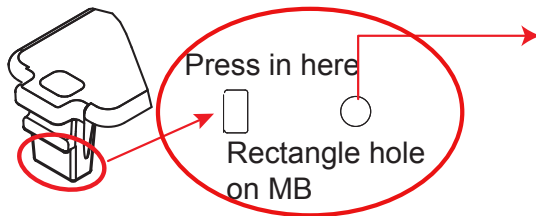
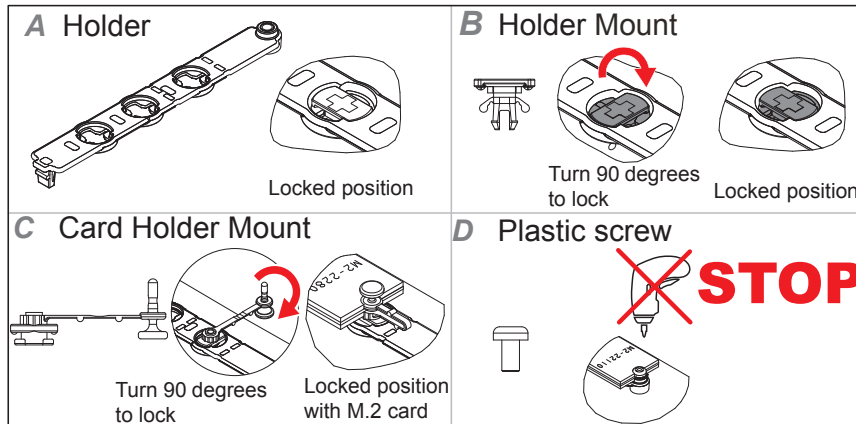

Hole Location on the MB 42	
M.2 Card 60	A+B+C
M.2 Card 80	A+B+C
M.2 Card 110	A+B+D

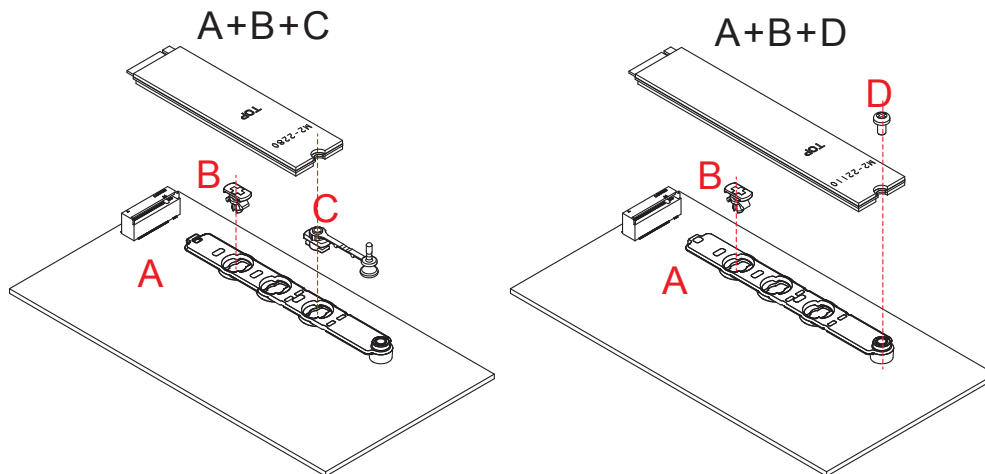

Figure 3-5. M.2 Mounting Instructions

Motherboard Battery

The motherboard uses non-volatile memory to retain system information when system power is removed. This memory is powered by a lithium battery residing on the motherboard.

Replacing the Battery

Begin by removing power from the system as described in section 3.1.

1. Push aside the small clamp that covers the edge of the battery. When the battery is released, lift it out of the holder.
2. To insert a new battery, slide one edge under the lip of the holder with the positive (+) side facing up. Then push the other side down until the clamp snaps over it.

Note: Please handle used batteries carefully. Do not damage the battery in any way; a damaged battery may release hazardous materials into the environment. Do not discard a used battery in the garbage or a public landfill. Please comply with the regulations set up by your local hazardous waste management agency to dispose of your used battery properly.

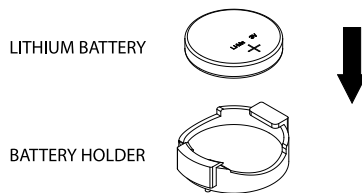

Figure 3-6. Installing the Onboard Battery

Warning: There is a danger of explosion if the onboard battery is installed upside down (which reverses its polarities). This battery must be replaced only with the same or an equivalent type recommended by the manufacturer (CR2032).

3.4 Chassis Components

Storage Drives

The standard system provides hot-swap drive bays for eight 3.5" SATA drives covered by the front bezel. Alternatively, each bay can house a 2.5" SATA drive with an optional converter (pn MCP-220-00080-0B). The drive IDs for these bays are preconfigured as 0 through 7 from bottom to top.

The drives are hot-swappable, meaning they can be removed and replaced without powering down the system, if that capability is supported by your operating system. The drives are mounted in drive carriers to simplify their installation and removal from the chassis. The carriers also promote airflow for the system. For this reason, even carriers without drives must remain in the server.

There are several options that provide additional SAS or SATA storage drives if an optional SAS RAID controller card is purchased. Each 5.25" bay can house one 3.5" drive, or two 2.5" drives with a bracket. Or two 5.25" bays can be replaced by an optional enclosure called a *mobile rack* that houses eight hot-swap 2.5" drives. Additional cables are also required.

Note: Enterprise level hard disk drives are recommended for use in Supermicro chassis and servers. For information on recommended HDDs, visit the Supermicro website at <http://www.supermicro.com/products/nfo/files/storage/SBB-HDDCompList.pdf>.

The server also supports PCIe M.2 storage that can be installed directly on the motherboard. See Section 3.3.

Drive Indicators

Each hot-swap drive has two LED indicators: an activity indicator and a status indicator. In RAID configurations, the status indicator lights to indicate the status of the drive. In non-RAID configurations, the status indicator remains off. See the table below for details.

Drive Carrier LED Indicators			
	Color	Blinking Pattern	Behavior for Device
Activity LED	Off		No drive, or SATA drive installed
	Blue	Solid On	SAS drive installed
	Blue	Blinking	I/O activity
Status LED	Red	Solid On	Failure of drive with RSTe support
	Red	Blinking at 1 Hz	Rebuild drive with RSTe support
	Red	Blinking with two blinks and one stop at 1 Hz	Hot spare for drive with RSTe support
	Red	On for five seconds, then off	Power on for drive with RSTe support
	Red	Blinking at 4 Hz	Identify drive with RSTe support

Installing the Standard 3.5" Drives

Removing Drive Carriers from the Chassis

1. Swing open the front bezel.
2. Press the release button on the drive carrier. This extends the drive carrier handle.



Figure 3-7. Removing a Drive Carrier

3. Use the handle to pull the carrier out of the chassis.
4. Remove the dummy drive from the carrier.

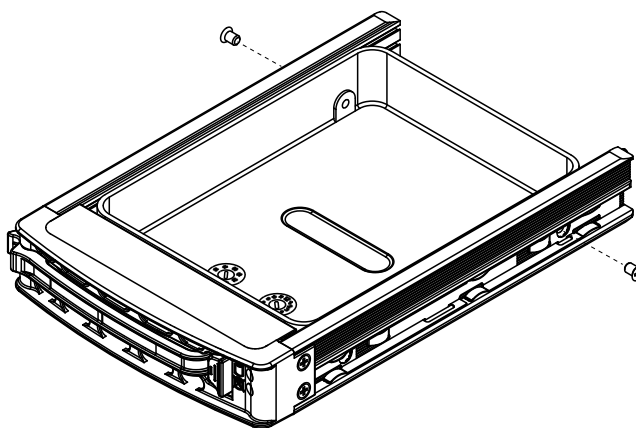

Figure 3-8. Removing the Dummy Drive

Caution: Except for short periods of time (swapping drives), do not operate the server with the drive carriers removed from the bays, regardless of how many drives are installed, for proper airflow.

Installing a Hard Drive

1. Place the hard drive carrier on a flat surface.
2. Insert the hard drive into the carrier with the printed circuit board side facing downward and so that the mounting holes in the drive align with those in the drive carrier.
3. Secure the hard drive to the carrier with the screws included with the hard drive.
4. Use the open handle of the drive carrier to insert the drive carrier into the open drive bay.
5. Secure the drive carrier into the drive bay by closing the drive carrier handle.

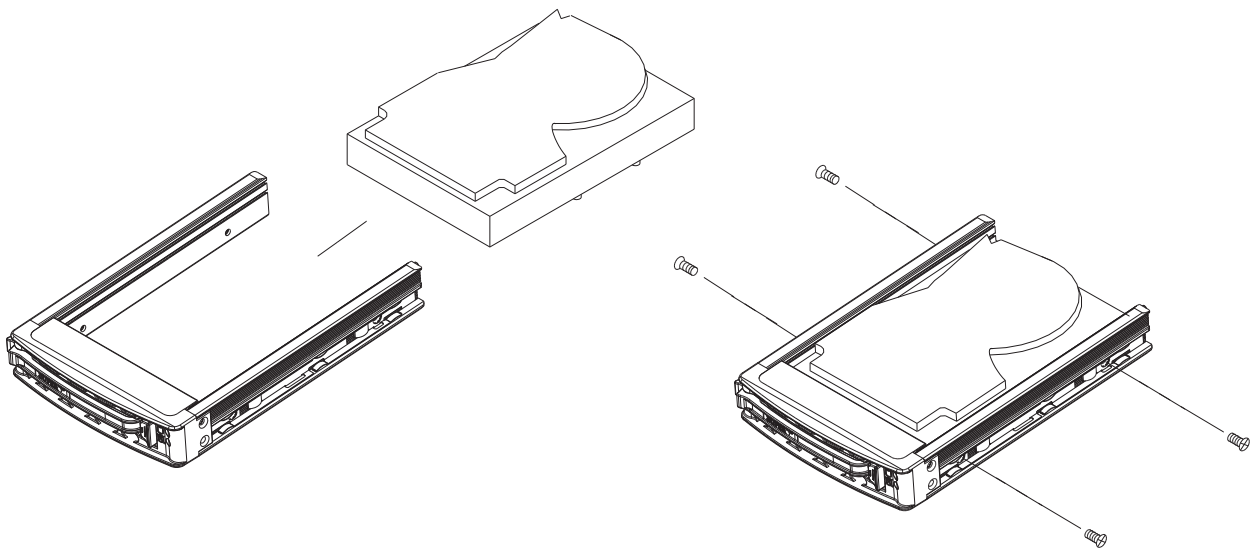

Figure 3-9. Mounting a Drive in a Carrier

Configuring the 5.25" Drive Bays

The control panel/drive module includes three 5.25" drive bays under the front control panel. It can be set up in a variety of configurations to suit the user's needs.

- Up to three 5.25" peripheral drives, such as a DVD drive
- One or two additional fixed SATA, SAS or solid state drives in a single tray
- A mobile rack with eight additional 2.5" hot-swap hard drives (replaces two 5.25" bays; requires an optional expansion card and cables)
- A combination of the above

Accessing the 5.25" Trays

1. Open the chassis cover.
2. Locate the drive tray and pull the appropriate release tab.
3. Push the drive tray out of the front of the chassis.

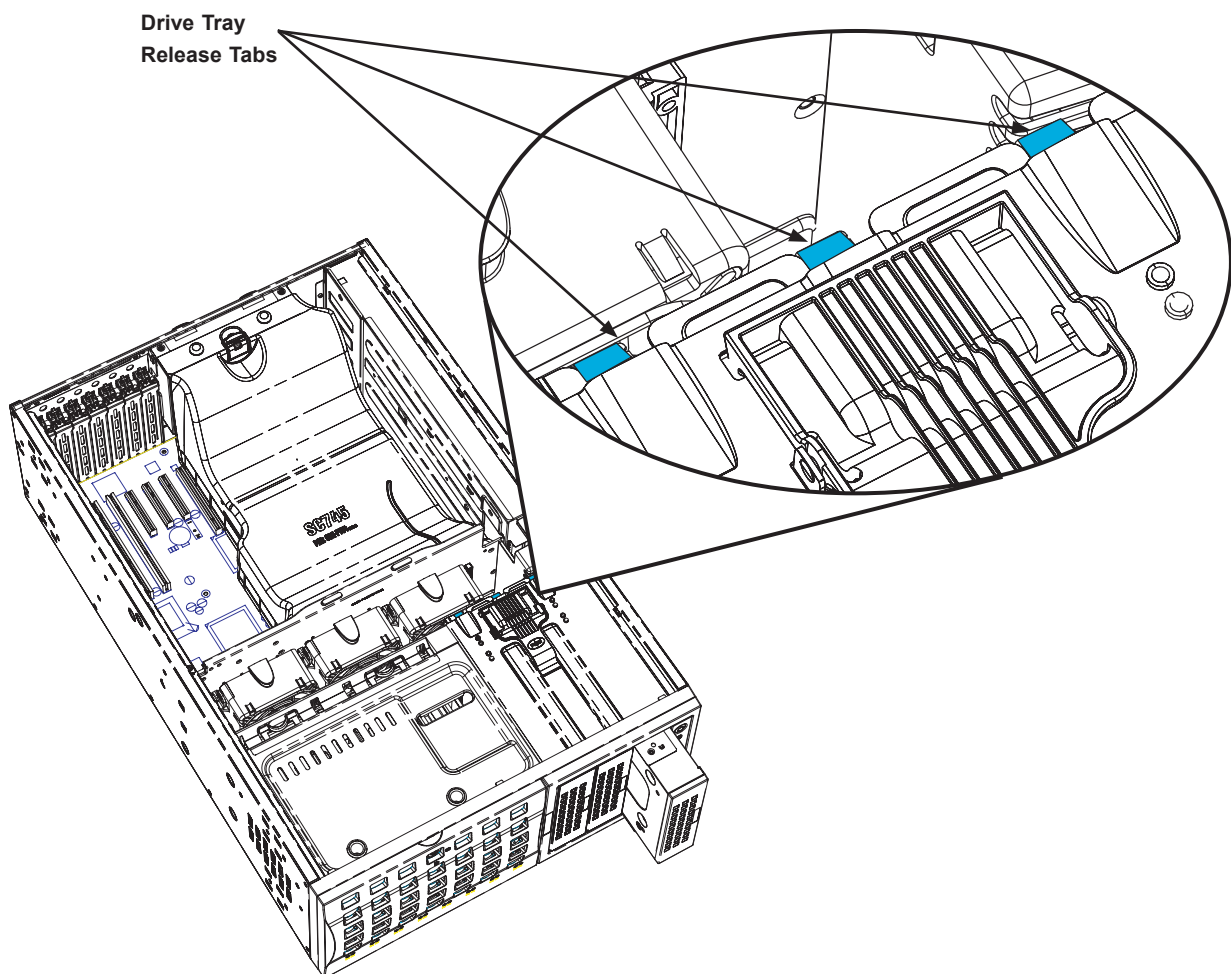

Figure 3-10. Removing a Drive Tray

Installing a Storage Drive into a 5.25" Tray

One 3.5" drive, or two 2.5" drives with an optional bracket (pn MCP-220-00044-0N) can be installed. An optional expansion card and cables are also required.

1. Remove the tray from the drive bay.
2. For a 3.5" drive, place the drive in the drive tray, and secure the drive to the tray with four screws from the bottom.

For one or two 2.5" drives, install the drives into the special purpose bracket, then secure the bracket to drive tray with screws through the bottom of the tray.

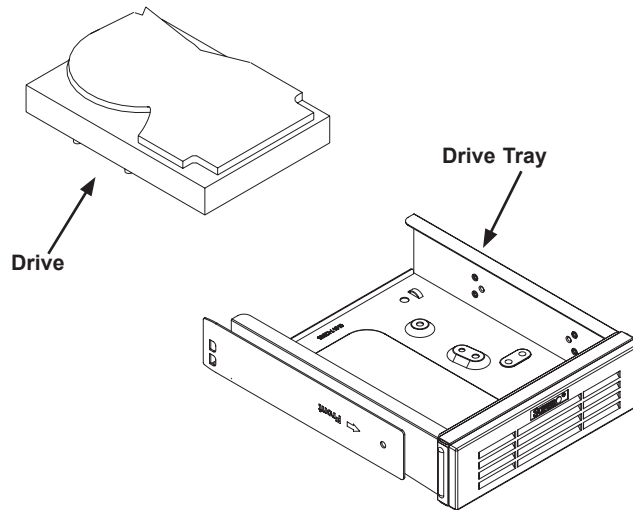

Figure 3-11. Installing a 3.5" Drive to the Drive Tray

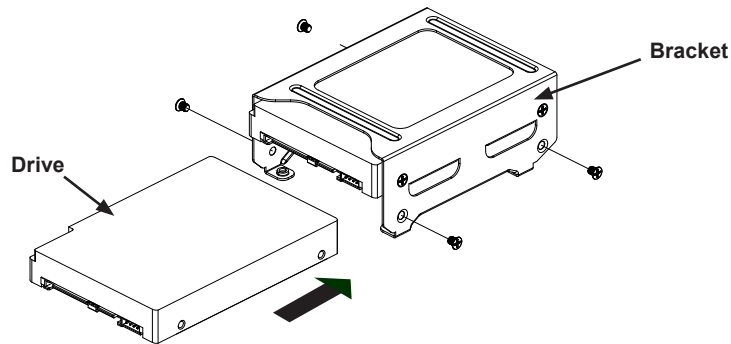

Figure 3-12. Installing 2.5" Drives into the Bracket

3. Slide the drive tray into the chassis until the tray clicks into place.
4. Connect the data and power cables for the new drive.
5. Replace the chassis cover and power up the system.

Installing a 5.25" Peripheral Device

An optional peripheral device such as a DVD drive can be installed in a 5.25" bay.

1. Remove the tray from the drive bay.
2. Re-use the side rails from the tray and install them onto the peripheral device.

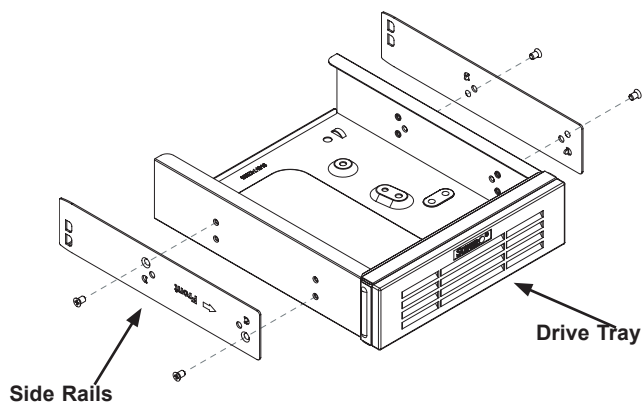

Figure 3-13. Removing Rails from the Drive Tray

3. Insert the new device in the slot until the tab locks in place.
4. Connect the data and power cables.
5. Replace the chassis cover and power up the system.

Additional Storage Drives in a Mobile Rack

The chassis accepts a Supermicro mobile rack (pn CSE-M28SABP) in place of two 5.25" bays. This adds eight hot-swap 2.5" SAS or SATA drives. An optional expansion card and cables are also required.

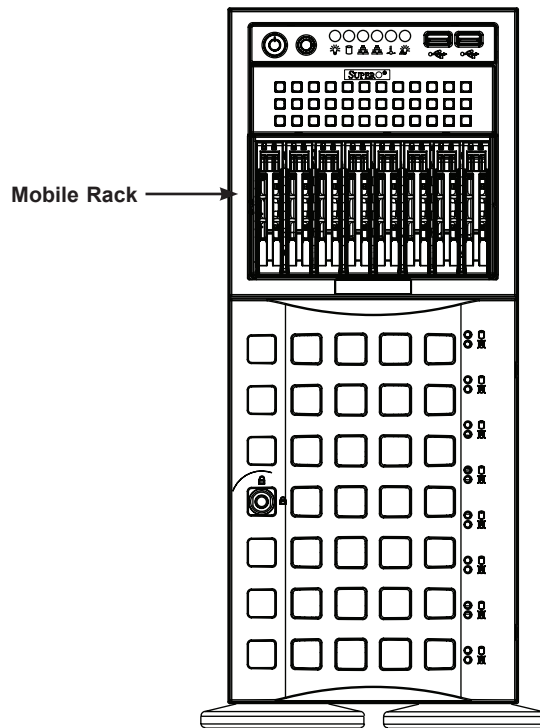

Figure 3-14. Chassis with a Mobile Rack Installed

Installing the Mobile Rack

1. Remove two adjacent trays from the drive bays.
2. Remove the drive tray rails.

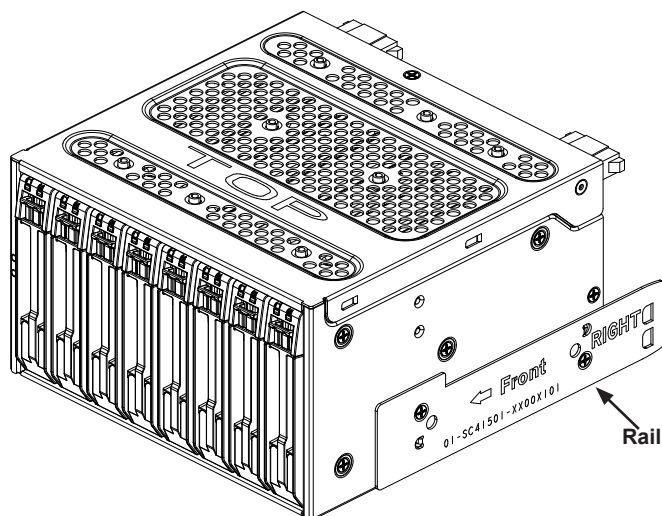

Figure 3-15. Mobile Rack with Drive Tray Rails

3. Install a drive tray rail onto each side of the mobile rack. Make sure the arrow on the rail points toward the front of the chassis.
4. Slide the mobile rack into the chassis.
5. Connect the data and power cables.

Installing Expansion Cards

The system can accommodate six PCIe cards. The chassis has seven slots, but the slot nearest the chassis top is not supported by this motherboard.

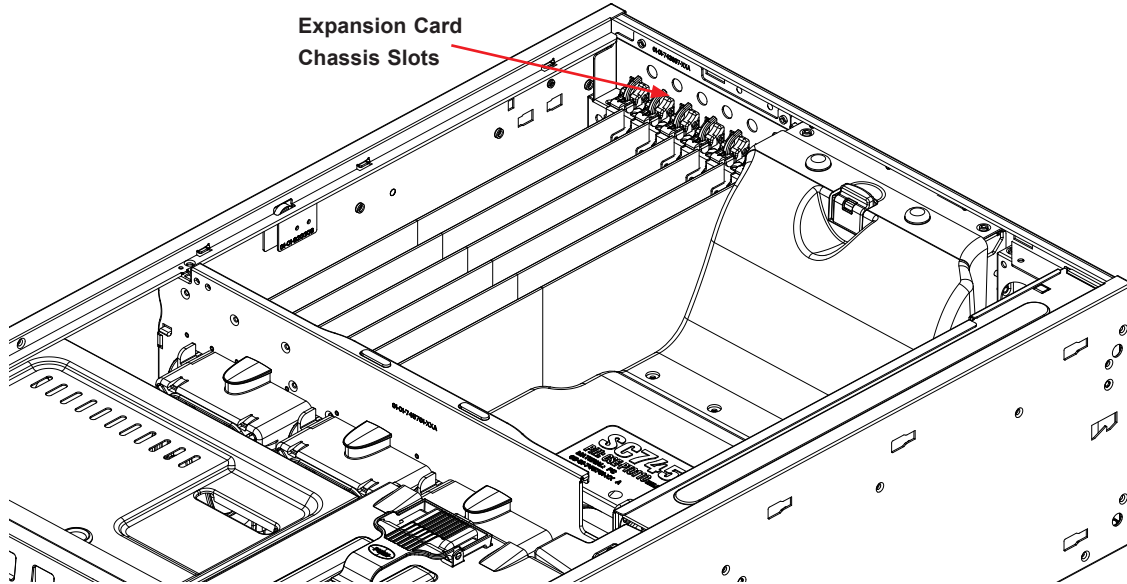

Figure 3-16. PCI Slots

Installing an Expansion Card

1. Power down the system and remove the cover.
2. In the rear of the chassis, push on PCI shield lock, then lift the lock.
3. Remove the screw holding the PCI shield in place and remove the shield.
4. Push the expansion card into the expansion slot on the motherboard while aligning it with the chassis slot in the rear of the chassis.
5. Secure the expansion card shield onto the rear of the chassis with a screw and the lock.

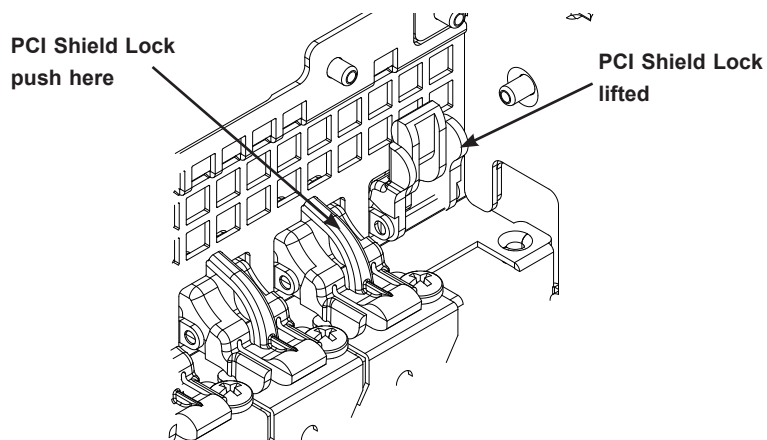

Figure 3-17. Removing a Blank PCI Shield

System Cooling

Three 8-cm fans located in the center of the chassis provide cooling airflow while two 8-cm exhaust fans at the rear of the chassis expel hot air. The chassis is also fitted with an air shroud to concentrate the flow of cooling air over the areas of highest generated heat. The fans should all be connected to headers on the motherboard (see Chapter 4). Each power supply module also has a cooling fan.

Chassis Fans

Under normal operation, all three chassis fans and both exhaust fans run continuously. They can be replaced without powering down the system (hot-swap).

Replacing Chassis Cooling Fans

1. Depress the locking tab on the failed fan.
 - On a mid-chassis fan, push the tab on the side of the housing inward.
 - On an exhaust fan, push down on the colored tab.
2. With the tab depressed, pull the unit straight out.
3. Replace the failed fan, noting the air flow direction. It should click into place. Check that the fan is working before replacing the chassis cover.

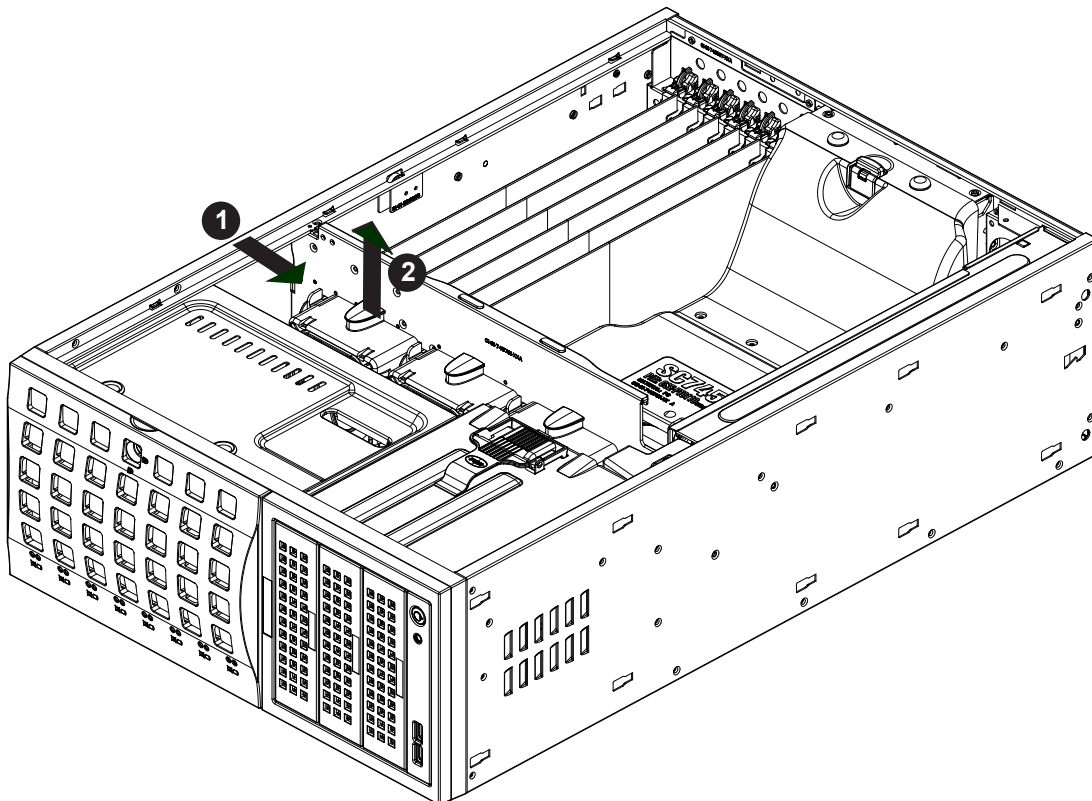

Figure 3-18. Removing a Chassis Fan

Air Shroud

Air shrouds concentrate airflow to maximize fan efficiency. It covers the processors and heatsinks.

Installing the Air Shroud

The air shroud fits behind the two fans closest to the power supply. Align the pins and press the air shroud into the chassis. It should click into place.

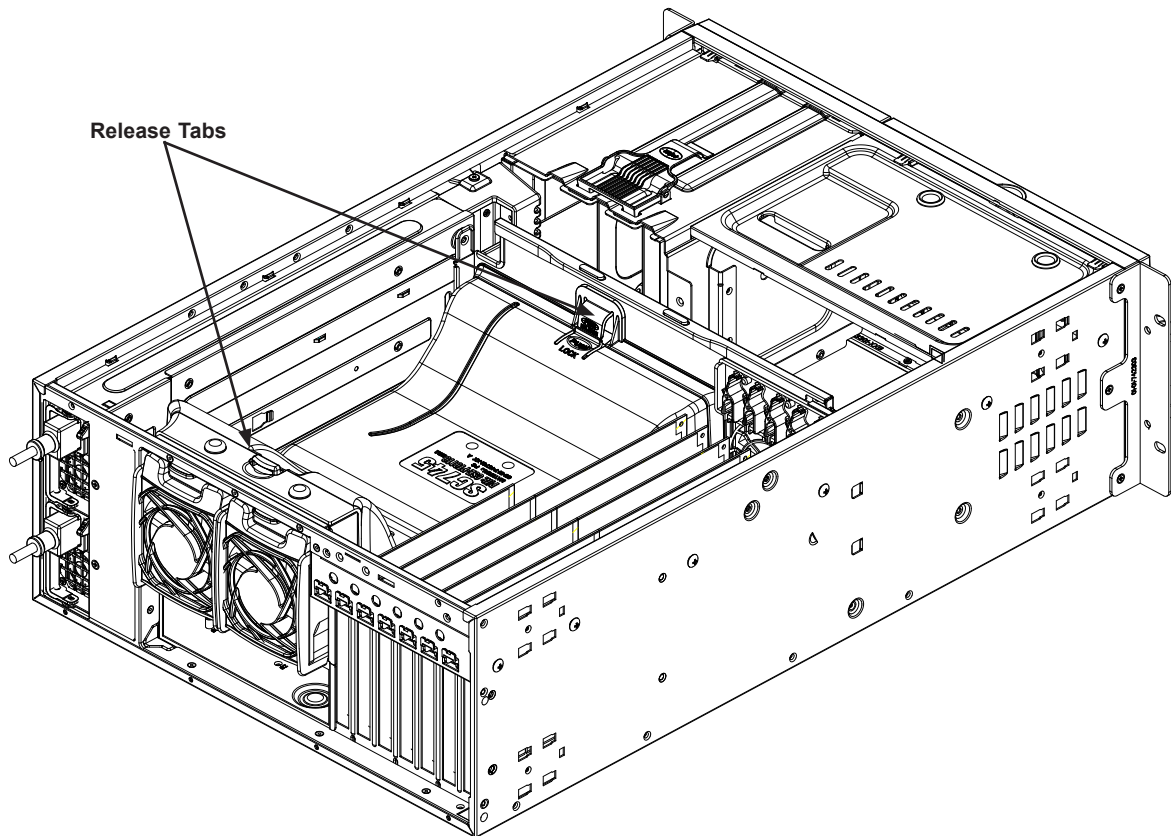

Figure 3-19. Installing the Air Shroud

To remove the air shroud, press the release tabs at the front and rear of the shroud to unlock it, then lift it out.

Power Supply

The system has a redundant power supply consisting of two power modules. Each power supply module has an auto-switching capability, which enables it to automatically sense and operate at a 100 V – 240 V input voltage.

If either of the two power supply modules fail, the other module will take the full load and allow the system to continue operation without interruption. The PWR Fail LED will illuminate and remain on until the failed unit has been replaced. The hot-swap capability of the power supply modules allows you to replace the failed module without powering down the system. Replacement units can be ordered directly from Supermicro (see contact information in the Preface).

Power Supply LEDs

On the rear of the power supply module, an LED displays the status.

- **Solid Green:** When illuminated, indicates that the power supply is on.
- **Solid Amber:** When illuminated, indicates the power supply is plugged in and turned off, or the system is off but in an abnormal state.
- **Blinking Amber:** When blinking, this system power supply temperature has reached 63C. The system will automatically power-down when the power supply temperature reaches 70C and restart when the power supply temperature goes below 60C.

Replacing the Power Supply

You do not need to shut down the system to replace a power supply module.

1. Unplug the AC power cord from the failed power supply module.
2. Push the release tab on the power module to the side to unlock it then grasp the handle to pull it from the chassis.

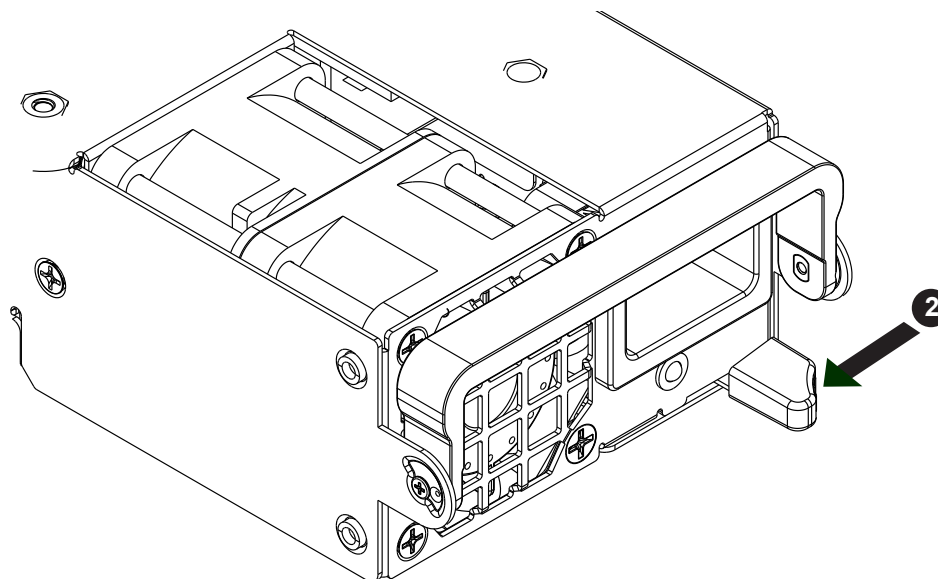

Figure 3-20. Power Supply Release Tab

3. Replace the failed module with another unit of the same model.
4. Push the new module all the way into the open bay until the release tab clicks into a locked position.
5. Plug the AC power cord back into the newly installed power module.

Removing the Front Bezel

If you wish to remove the front bezel, push on the three tabs on the inside of the left lip of the front chassis cover. Then slightly swing out the same (left) side of the cover, about $\frac{1}{2}$ inch only. Remove by pushing on the open side of the cover to remove it from the chassis (do not try to swing or pull it straight out after opening the left side).

Chapter 4

Motherboard Connections

This section describes the connections on the motherboard and provides pinout definitions. Note that depending on how the system is configured, not all connections are required. The LEDs on the motherboard are also described here. A motherboard layout indicating component locations may be found in Chapter 1.

Please review the safety precautions in Appendix B before installing or removing components.

4.1 Power Connections

Three power connections on the X11DPI-N(T) must be connected to the power supply. The wiring is included with the power supply.

- One 24-pin Primary ATX Power (JPWR3)
- Two 8-pin Processor Power (JPWR1, JPWR2)

Main ATX Power Connector

The primary power connector (JPWR3) meets the ATX SSI EPS 24-pin specification. You must also connect the 8-pin (JPWR1, JPWR2) processor power connectors to your power supply.

ATX Power 24-pin Connector Pin Definitions			
Pin#	Definition	Pin#	Definition
13	+3.3V	1	+3.3V
14	-12V	2	+3.3V
15	COM	3	COM
16	PS_ON	4	+5V
17	COM	5	COM
18	COM	6	+5V
19	COM	7	COM
20	Res (NC)	8	PWR_OK
21	+5V	9	5VSB
22	+5V	10	+12V
23	+5V	11	+12V
24	COM	12	+3.3V

Required Connection

Important: To provide adequate power to the motherboard, connect the 24-pin *and* the 8-pin power connectors to the power supply. Failure to do so may void the manufacturer's warranty on your power supply and motherboard.

Processor Power Connector

JPWR1 and JPWR2 must also be connected to the power supply. These connectors are used to power the processors.

+12V 8-pin Power Pin Definitions	
Pin#	Definition
1 - 4	Ground
5 - 8	+12V

Required Connection

4.2 Headers and Connectors

Fan Headers

There are eight fan headers (FAN1-6, FANA, FANB) on the motherboard. These are 4-pin fan headers; pins 1-3 are backward compatible with traditional 3-pin fans. The onboard fan speeds are controlled by Thermal Management via IPMI. When using Thermal Management setting, please use all 3-pin fans or all 4-pin fans.

Fan Header Pin Definitions	
Pin#	Definition
1	Ground (Black)
2	+12V (Red)
3	Tachometer
4	PWM Control

I-SATA 3.0 and S-SATA 3.0 Ports

SATA is supported on the X11DPi-N(T) motherboard by three iPass connectors and two SATA powered ports. The powered ports, S-SATA4/S-SATA5, are yellow connectors with power pins built in. They can be used with Supermicro SuperDOMs and do not require external power cables.

Host Fabric Interface (HFI) Carrier Card Sideband Headers (for the SKX-F CPU Only)

Two Host Fabric Interface carrier card headers are located at JHFI1/JHFI2 on the motherboard. A JHFI Sideband header is used when a SKX-F processor is installed on the motherboard. Use a Host Fabric Interface (HFI) sideband cable to connect the carrier card to the JHFI header, and use an Internal-Faceplate-to-Processor cable (IFPA54B) to connect the carrier card to the SKX-F processor to enhance system performance. Note that in a dual-processor system, JHFI1 is used for CPU1, and JHFI2 is for CPU2.

TPM Header

The JTPM1 header is used to connect a Trusted Platform Module (TPM)/Port 80, which is available from a third-party vendor. A TPM/Port 80 connector is a security device that supports encryption and authentication in hard drives. It allows the motherboard to deny access if the TPM associated with the hard drive is not installed in the system.

RAID Key Header

A RAID Key header is located at JRK1 on the motherboard. It supports VMD used in creating optional advanced NVMe RAID configurations.

Intel RAID Key Pin Definitions	
Pin#	Definition
1	Ground
2	+3.3 V Standby
3	Ground
4	PCH RAID key

SGPIO Header

The T-SGPIO3 (Serial General Purpose Input/Output) header is used to communicate with the enclosure management chip on the backplane.

SGPIO Header Pin Definitions			
Pin#	Definition	Pin#	Definition
1	NC	2	NC
3	Ground	4	DATA Out
5	Load	6	Ground
7	Clock	8	NC

NC = No Connection

Standby Power

The Standby Power header is located at JSTBY1 on the motherboard. You must have a card with a Standby Power connector and a cable to use this feature.

Standby Power Pin Definitions	
Pin#	Definition
1	+5V Standby
2	Ground
3	No Connection

Power SMBus (I²C) Header

The Power System Management Bus (I²C) connector (JPI²C1) monitors the power supply, fan, and system temperatures.

Power SMB Header Pin Definitions	
Pin#	Definition
1	Clock
2	Data
3	PMBUS_Alert
4	Ground
5	+3.3V

4-pin BMC External I²C Header

A System Management Bus header for IPMI 2.0 is located at JIPMB1. Connect the appropriate cable here to use the IPMB I²C connection on your system.

External I ² C Header Pin Definitions	
Pin#	Definition
1	Data
2	Ground
3	Clock
4	No Connection

Chassis Intrusion

A chassis Intrusion header is located at JL1 on the motherboard. Attach the appropriate cable from the chassis to alert you when the chassis is opened.

Chassis Intrusion Pin Definitions	
Pin#	Definition
1	Intrusion Input
2	Ground

NVMe SMBus Headers

NVMe SMB (I²C) headers (JNVI2C1/2) are used for PCIe SMBus clock and data connections and provide hot-plug support by a dedicated SMBus interface. This feature is only available for a Supermicro complete system with a proprietary NVMe add-on card and cable installed.

NVMe SMBus Header Pin Definitions	
Pin#	Definition
1	Data
2	Ground
3	Clock
4	VICCIO

NVMe Connectors

NVMe I²C headers used for PCIe hot-plug SMBus clock and data connections. (A proprietary NVMe add-on card and cable are required; available for a Supermicro complete system only)

PCIe M.2 Slot

The motherboard has one M.2 slot (JM2_1). See Chapter 3 for details.

Control Panel

JF1 contains header pins for various control panel connections. See the figure below for the pin locations and definitions of the control panel buttons and LED indicators.

All JF1 wires have been bundled into a single cable to simplify this connection. Make sure the red wire plugs into pin 1 as marked on the motherboard. The other end connects to the control panel PCB board.

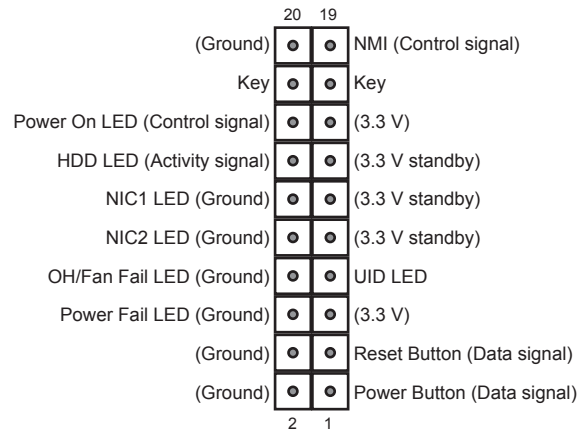

Figure 4-1. JF1: Control Panel Pins

Power Button

The Power Button connection is located on pins 1 and 2 of JF1. Momentarily contacting both pins will power on/off the system. This button can also be configured to function as a suspend button (with a setting in the BIOS--see Chapter 6). To turn off the power when the system is in suspend mode, press the button for 4 seconds or longer.

Power Button Pin Definitions (JF1)	
Pin#	Definition
1	Signal
2	Ground

Reset Button

The Reset Button connection is located on pins 3 and 4 of JF1. Attach it to a hardware reset switch on the computer case.

Reset Button Pin Definitions (JF1)	
Pin#	Definition
3	Reset
4	Ground

Power Fail LED

The Power Fail LED connection is located on pins 5 and 6 of JF1.

Power Fail LED Pin Definitions (JF1)	
Pin#	Definition
5	3.3V
6	PWR Supply Fail

Overheat (OH)/Fan Fail

Connect an LED cable to pins 7 and 8 of JF1 to use the Overheat/Fan Fail LED connections. The LED on pin 8 provides warnings of overheat or fan failure.

OH/Fan Fail Indicator Status	
Status	Definition
Off	Normal
On	Overheat
Flashing	Fan Fail

OH/Fan Fail LED Pin Definitions (JF1)	
Pin#	Definition
7	Blue LED
8	OH/Fan Fail LED

NIC1/NIC2 (LAN1/LAN2)

The NIC (Network Interface Controller) LED connection for LAN port 1 is located on pins 11 and 12 of JF1, and the LED connection for LAN Port 2 is on Pins 9 and 10. Attach the NIC LED cables here to display network activity.

LAN1/LAN2 LED Pin Definitions (JF1)	
Pin#	Definition
9	NIC2 Activity LED
10	NIC2 Link LED
11	NIC1 Activity LED
12	NIC1 Link LED

HDD LED/UID Switch

The HDD LED/UID Switch connection is located on pins 13 and 14 of JF1. Attach a cable to Pin 14 to show hard drive activity status. Attach a cable to Pin 13 to use UID switch. Refer to the table below for pin definitions.

HDD LED Pin Definitions (JF1)	
Pin#	Definition
13	3.3V Standby/UID Switch
14	HDD Active

Power LED

The Power LED connection is located on pins 15 and 16 of JF1.

Power LED Pin Definitions (JF1)	
Pin#	Definition
15	3.3V
16	Power LED

NMI Button

The non-maskable interrupt button header is located on pins 19 and 20 of JF1.

NMI Button Pin Definitions (JF1)	
Pin#	Definition
19	Control
20	Ground

Data Cables

The data cables in the system have been carefully routed to maintain airflow efficiency. If you disconnect any of these cables, take care to re-route them as they were originally when reconnecting them.

Important! Make sure the the cables do not come into contact with the fans.

4.3 Input/Output Ports and Interface Buttons

The rear I/O panel offers these ports and control switches.

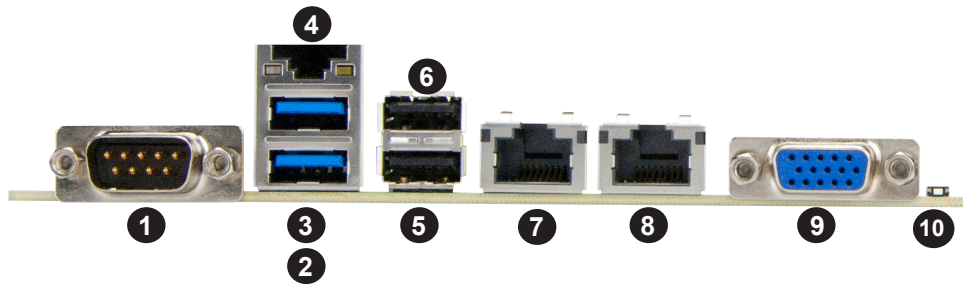

Figure 4-2. Back Panel I/O Ports

Back Panel I/O Ports			
No.	Description	No.	Description
1.	COM1	6.	USB 1
2.	USB 4	7.	GLAN1 (7049P-TR), 10G_LAN1 (7049P-TRT)
3.	USB 5	8.	GLAN2 (7049P-TR), 10G_LAN2 (7049P-TRT)
4.	IPMI LAN	9.	VGA
5.	USB 0	10.	Unit Identifier Switch (UID)

Serial Port

There is one COM port (COM1) on the I/O back panel and one COM header (COM2) on the motherboard.

Universal Serial Bus (USB) Ports

There are two USB 2.0 ports (USB0/1) and two USB 3.0 port (USB4/5) on the I/O back panel. There is one USB 2.0 header (USB2/3) and one USB 3.0 header (USB7/8) on the motherboard. USB6 is a Type A USB 3.0 header. The onboard headers can be used to provide front side USB access with a cable (not included).

IPMI Port

A LAN port is a dedicated connection for IPMI.

Ethernet Ports

Two Ethernet ports (LAN1, LAN2):

- X11DPi-NT supports 10GbE connections
- X11DPi-N supports 1 GbE connections

UID

The unit identifier (UID) switch toggles the UID LED indicator on or off. This indicator can be used to identify the node for troubleshooting or service.

4.4 Jumpers

Explanation of Jumpers

To modify the operation of the motherboard, jumpers are used to choose between optional settings. Jumpers create shorts between two pins to change the function associated with it. Pin 1 is identified with a square solder pad on the printed circuit board. See the motherboard layout page for jumper locations.

Note: On a two-pin jumper, "Closed" means the jumper is on both pins and "Open" indicates the jumper is either on only one pin or has been completely removed.

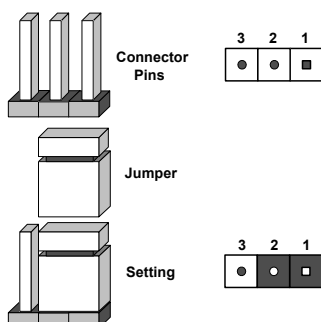

CMOS Clear

JBT1 is used to clear CMOS, which will also clear any passwords. Instead of pins, this jumper consists of contact pads to prevent accidentally clearing the contents of CMOS.

To Clear CMOS

1. First power down the system and unplug the power cord(s).
2. Remove the cover of the chassis to access the motherboard.
3. Remove the onboard battery from the motherboard.
4. Short the CMOS pads with a metal object such as a small screwdriver for at least four seconds.
5. Remove the screwdriver (or shorting device).
6. Replace the cover, reconnect the power cord(s) and power on the system.

Notes: Clearing CMOS will also clear all passwords.

Do not use the PW_ON connector to clear CMOS.



JBT1 contact pads

Management Engine (ME) Recovery

Use jumper JPME1 to select ME Firmware Recovery mode, which will limit resource allocation for essential system operation only in order to maintain normal power operation and management. In the single operation mode, online upgrade will be available via Recovery mode. See the table below for jumper settings.

Manufacturer Mode Jumper Settings	
Jumper Setting	Definition
Pins 1-2	Normal
Pins 2-3	ME Recovery

Manufacturer Mode Select

Close pin 2 and pin 3 of jumper JPME2 to bypass SPI flash security and force the system to operate in the manufacturer mode, which will allow the user to flash the system firmware from a host server for system setting modifications. The default setting is Normal.

Manufacturer Mode Jumper Settings	
Jumper Setting	Definition
Pins 1-2	Normal (Default)
Pins 2-3	Manufacturer Mode

Watch Dog

JWD1 controls the Watch Dog function. Watch Dog is a monitor that can reboot the system when a software application hangs. Jumping pins 1-2 will cause Watch Dog to reset the system if an application hangs. Jumping pins 2-3 will generate a non-maskable interrupt signal for the application that hangs. Watch Dog must also be enabled in BIOS. The default setting is Reset.

Note: When Watch Dog is enabled, the user needs to write their own application software to disable it.

Watch Dog Jumper Settings	
Jumper Setting	Definition
Pins 1-2	Reset
Pins 2-3	NMI
Open	Disabled

I2C Bus for VRM

Jumpers JVRM1 and JVRM2 allow the BMC or the PCH to access CPU and memory VRM controllers.

VRM Jumper Settings	
Jumper Setting	Definition
On	BMC (Normal)
Off	PCH

4.5 LED Indicators

LAN LEDs

The LAN ports are located on the I/O back panel on the motherboard. Each Ethernet LAN port has two LEDs. The yellow LED indicates activity. Link LED, located on the left side of the LAN port, may be green, amber or off indicating the speed of the connection.

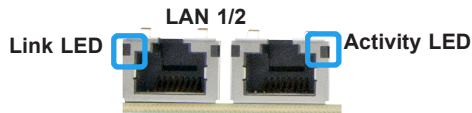

LAN Link Indicator LED Settings	
LED Color	Definition
Off	No Connection, 10 or 100 Mbps
Green	10 Gbps (7049P-TRT only)
Amber	1 Gbps

IPMI LAN LED

The yellow LED indicates activity, while the green/amber LED indicates the speed of the connection.

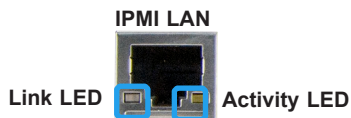

IPMI LAN LED Link LED (left)	
LED Color	Definition
Amber: Solid	1 Gb/s
Green: Solid	100 Mb/s

BMC Heartbeat LED

LED M1 is the BMC heartbeat indicator. When the LED is blinking green, BMC is functioning normally.

BMC Heartbeat LED Indicator	
LED Color	Definition
Green: Blinking	BMC Normal

Onboard Power LED

The Onboard Power LED is located at LE2 on the motherboard. When this LED is on, the system is on. Be sure to turn off the system and unplug the power cord before removing or installing components.

Onboard Power LED Indicator	
LED Color	Definition
Off	System Off (power cable not connected)
Green	System On

M.2 Power LED

The LE3 indicator shows when M.2 is active.

Unit ID LED

A rear UID LED indicator at LE1 is located near the UID switch on the I/O back panel. The switch toggles the LED indicator to provide easy identification of a system when, for example, it may need service.

Chapter 5

Software

After the hardware has been installed, you should install the Operating System (OS), configure RAID settings and install the drivers. Necessary drivers and utilities may be found at <ftp://ftp.supermicro.com/driver>.

5.1 OS Installation

You must first configure RAID settings (if using RAID) before you install the Windows OS and the software drivers. To configure RAID settings, please refer to the RAID Configuration User Guides posted on our website at www.supermicro.com/support/manuals.

Installing the Windows OS for a RAID System

1. Insert Microsoft's Windows Setup DVD in the DVD drive and the system will start booting up from the DVD.
2. Insert the USB stick containing Windows drivers to a USB port on the system.
Note: for older legacy OS's, please use a method to slipstream the drivers.
3. Select the partition on the drive in which to install Windows.
4. Browse the USB folder for the proper driver files.
5. Choose the RAID driver indicated in the Windows OS Setup screen, then choose the hard drive in which you want to install it.
6. Once all devices are specified, continue with the installation.
7. After the Windows OS installation is completed, the system will automatically reboot.

Installing Windows to a Non-RAID System

1. Insert Microsoft's Windows OS Setup DVD in the DVD-ROM drive and the system will start booting up from the DVD.
2. Continue with the installation. The Windows OS Setup screen will display.
3. From the Windows OS Setup screen, press the <Enter> key. The OS Setup will automatically load all device files and then continue with the Windows installation.
4. After the installation has completed, the system will automatically reboot.

5.2 Driver Installation

The Supermicro FTP site contains drivers and utilities for your system at <ftp://ftp.supermicro.com>. Some of these must be installed, such as the chipset driver.

After accessing the FTP site, go into the CDR_Images directory and locate the ISO file for your motherboard. Download this file to create a DVD of the drivers and utilities it contains. (You may also use a utility to extract the ISO file if preferred.)

After creating a DVD with the ISO files, insert the disk into the DVD drive on your system and the display shown in Figure 5-1 should appear.

Another option is to go to the Supermicro website at <http://www.supermicro.com/products/>. Find the product page for your motherboard here, where you may download individual drivers and utilities to your hard drive or a USB flash drive and install from there.

Note: To install the Windows OS, please refer to the instructions posted on our website at <http://www.supermicro.com/support/manuals/>.

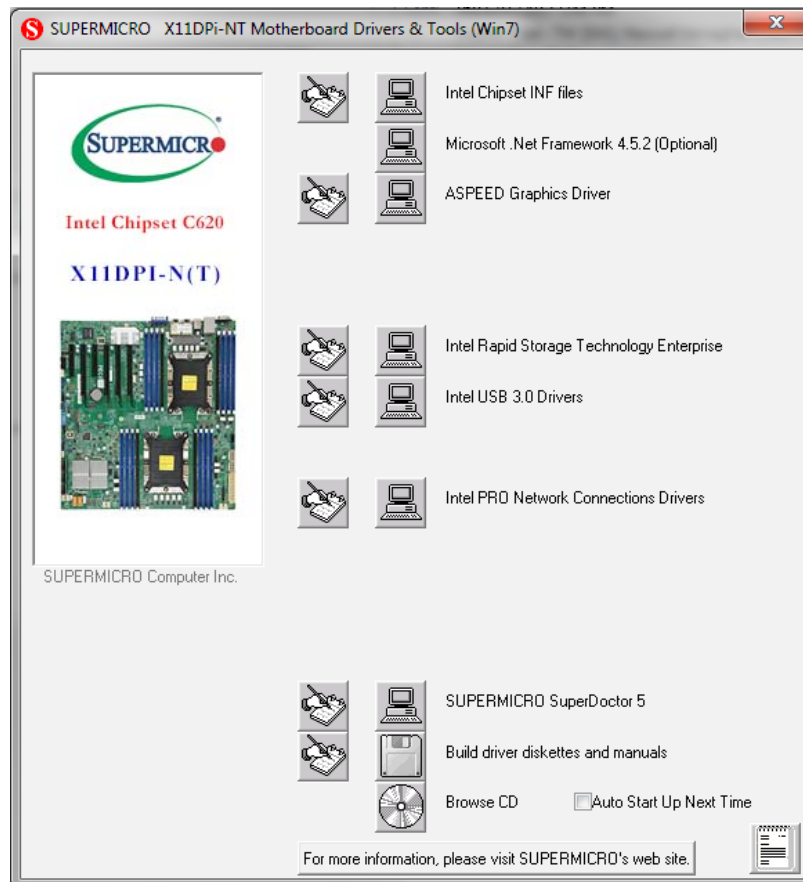

Figure 5-1. Driver & Tool Installation Screen

Note: Click the icons showing a hand writing on paper to view the readme files for each item. Click the computer icons to the right of these items to install each item (from top to the bottom) one at a time. **After installing each item, you must re-boot the system before moving on to the next item on the list.** The bottom icon with a CD on it allows you to view the entire contents.

5.3 SuperDoctor® 5

The Supermicro SuperDoctor 5 is a program that functions in a command-line or web-based interface for Windows and Linux operating systems. The program monitors such system health information as CPU temperature, system voltages, system power consumption, fan speed, and provides alerts via email or Simple Network Management Protocol (SNMP).

SuperDoctor 5 comes in local and remote management versions and can be used with Nagios to maximize your system monitoring needs. With SuperDoctor 5 Management Server (SSM Server), you can remotely control power on/off and reset chassis intrusion for multiple systems with SuperDoctor 5 or IPMI. SuperDoctor 5 Management Server monitors HTTP, FTP, and SMTP services to optimize the efficiency of your operation.

Note: The default User Name and Password for SuperDoctor 5 is ADMIN / ADMIN.



Figure 5-2. SuperDoctor 5 Interface Display Screen (Health Information)

5.4 IPMI

The X11DPi-N(T) support the Intelligent Platform Management Interface (IPMI). IPMI is used to provide remote access, monitoring and management. There are several BIOS settings that are related to IPMI.

For general documentation and information on IPMI, please visit our website at: <http://www.supermicro.com/products/nfo/IPMI.cfm>.

Chapter 6

BIOS

6.1 Introduction

This chapter describes the AMI BIOS setup utility for the X11DPi-N(T) and provides the instructions on navigating the setup screens. The BIOS is stored in a Flash EEPROM and can be updated.

Note: Due to periodic changes to the BIOS, some settings may have been added or deleted since this manual was published.

Starting BIOS Setup Utility

To enter the AMI BIOS setup utility screens, press the <Delete> key while the system is booting up. (There are a few cases when other keys are used, such as <F1>, <F2>, etc.)

The BIOS screens have three main frames. The large left frame displays options can be configured by the user. These are blue. When an option is selected, it is highlighted in white. Settings printed in **Bold** are the default values.

In the left frame, a " ►" indicates a submenu. Highlighting such an item and pressing the <Enter> key opens the list of settings in that submenu.

The upper right frame displays helpful information for the user. The AMI BIOS has default informational messages built in. The manufacturer retains the option to include, omit, or change any of these informational messages.

The lower right frame lists navigational methods. The AMI BIOS setup utility uses a key-based navigation system called *hot keys*. Most of these hot keys can be used at any time during setup navigation. These keys include <F3>, <F4>, <Enter>, <ESC>, arrow keys, etc.

Some system parameters may be changed.

6.2 Main Setup

When running the AMI BIOS setup utility, it starts with the Main screen. You can always return to it by selecting the Main tab on the top of the screen.



The Main tab page allows you to set the date and time, and it displays system information.

System Date/System Time

Use this option to change the system date and time. Highlight *System Date* or *System Time* using the arrow keys. Enter new values using the keyboard. Press the <Tab> key or the arrow keys to move between fields. The date must be entered in MM/DD/YYYY format. The time is entered in HH:MM:SS format.

Note: The time is in the 24-hour format. For example, 5:30 P.M. appears as 17:30:00. The date's default value is 01/01/2016 after RTC reset.

Supermicro X11DPI-N/X11DPI-NT (Motherboard model)

BIOS Version

Build Date (of the BIOS)

CPLD (Complex Programmable Logic Device) Version

Memory Information

Total Memory (for the system)

Memory Speed

6.3 Advanced Setup Configurations

Use the arrow keys to select the Advanced tab and press <Enter> to access the submenu items.

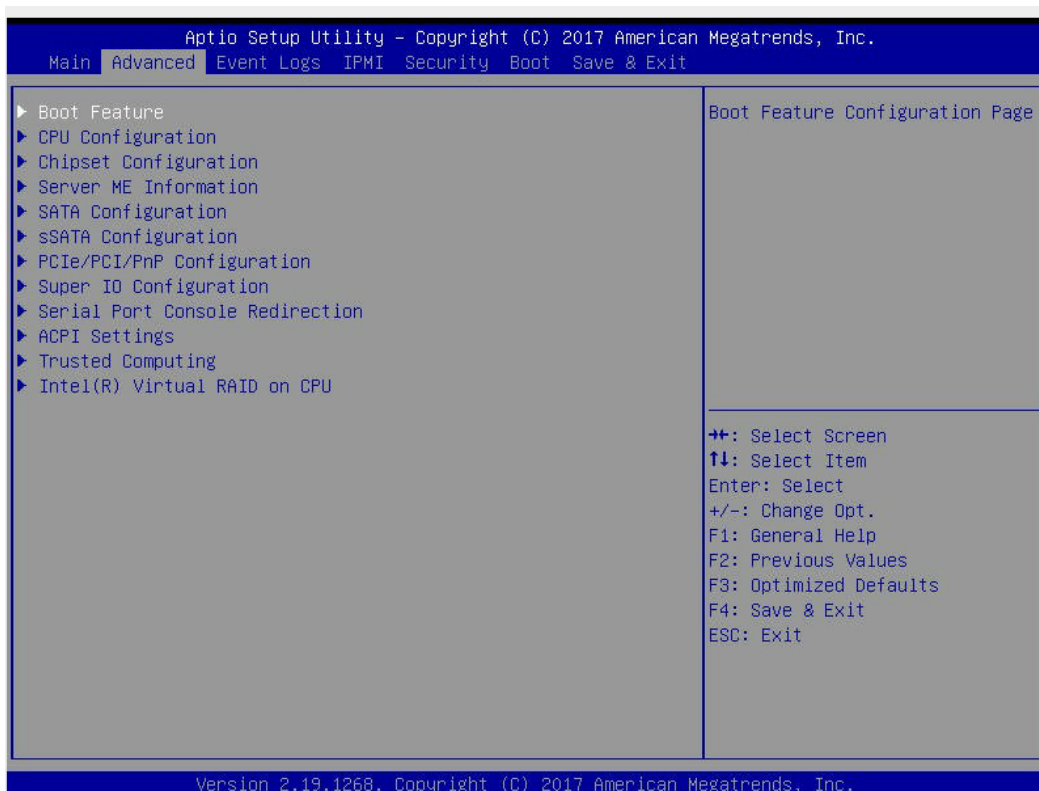

Caution: Take caution when changing the Advanced settings. An incorrect value, a very high DRAM frequency, or an incorrect DRAM timing setting may make the system unstable. If this occurs, revert to the manufacture default settings.

►Boot Configuration

Quiet Boot

Use this feature to select the screen between displaying POST messages or the OEM logo at bootup. Select Disabled to display the POST messages. Select Enabled to display the OEM logo instead of the normal POST messages. The options are **Enabled** and Disabled.

Note: POST message is always displayed regardless of the item setting.

CSM (Compatibility Support Module) Support

Select Enabled to enable CSM booting support which will allow a UEFI (Unified Extensible Firmware Interface)-compatible device to boot from a system that uses a legacy BIOS ROM. The options are **Enabled** and Disabled.

Option ROM Messages

Use this feature to set the display mode for the Option ROM. Select Keep Current to use the current AddOn ROM display setting. Select Force BIOS to use the Option ROM display mode set by the system BIOS. The options are **Force BIOS** and Keep Current.

Bootup NumLock State

Use this feature to set the Power-on state for the Numlock key. The options are Off and **On**.

Wait For 'F1' If Error

Select Enabled to force the system to wait until the 'F1' key is pressed if an error occurs. The options are Disabled and **Enabled**.

Interrupt 19 Capture

Interrupt 19 is the software interrupt that handles the boot disk function. When this item is set to Immediate, the ROM BIOS of the host adaptors will "capture" Interrupt 19 at bootup immediately and allow the drives that are attached to these host adaptors to function as bootable disks. If this item is set to Postponed, the ROM BIOS of the host adaptors will not capture Interrupt 19 immediately and allow the drives attached to these adaptors to function as bootable devices at bootup. The options are **Immediate** and Postponed.

Re-try Boot

When EFI (Expansible Firmware Interface) Boot is selected, the system BIOS will automatically reboot the system from an EFI boot device after an initial boot failure. Select Legacy Boot to allow the BIOS to automatically reboot the system from a Legacy boot device after an initial boot failure. The options are **Disabled**, Legacy Boot, and EFI Boot.

Power Configuration

Watch Dog Function

Select Enabled to allow the Watch Dog timer to reboot the system when it is inactive for more than 5 minutes. The options are Enabled and **Disabled**.

Power Button Function

This feature controls how the system shuts down when the power button is pressed. Select 4 Seconds Override for the user to power off the system after pressing and holding the power button for 4 seconds or longer. Select Instant Off to instantly power off the system as soon as the user presses the power button. The options are 4 Seconds Override and **Instant Off**.

Restore on AC Power Loss

Use this feature to set the power state after a power outage. Select Power-Off for the system power to remain off after a power loss. Select Power-On for the system power to be turned on after a power loss. Select Last State to allow the system to resume its last power state before a power loss. The options are Power-On, Stay-Off and **Last State**.

► CPU Configuration

Warning: Setting the wrong values in the following sections may cause the system to malfunction.

► Processor Configuration

The following CPU information will be displayed:

- Processor BSP Revision
- Processor Socket
- Processor ID
- Processor Frequency
- Processor Max Ratio
- Processor Min Ratio
- Microcode Revision
- L1 Cache RAM
- L2 Cache RAM
- L3 Cache RAM
- Processor 0 Version
- Processor 1 Version

Hyper-Threading (ALL)

Select Enable to use Intel Hyper-Threading Technology to enhance CPU performance. The options are **Enable** and Disable.

Execute Disable Bit (Available if supported by the OS & the CPU)

Select Enable to enable Execute Disable Bit support which will allow the processor to designate areas in the system memory where an application code can execute and where it cannot, thus preventing a worm or a virus from flooding illegal codes to overwhelm the processor, damaging the system during a virus attack. The options are **Enable** and Disable. (Refer to Intel and Microsoft websites for more information.)

Intel Virtualization Technology

Select Enable to use Intel Virtualization Technology which will allow the I/O device assignments to be directly reported to the VMM (Virtual Memory Management) through the DMAR ACPI tables. This feature offers fully-protected I/O resource-sharing across the Intel platforms, providing the user with greater reliability, security and availability in networking and data-sharing. The settings are **Enable** and Disable.

PPIN Control

Select Unlock/Enable to use the Protected-Processor Inventory Number (PPIN) in the system. The options are **Unlock/Enable** and Unlock/Disable.

Hardware Prefetcher (Available when supported by the CPU)

If this feature is set to Enable, the hardware prefetcher will prefetch streams of data and instructions from the main memory to the Level 2 (L2) cache to improve CPU performance. The options are Disable and **Enable**.

Adjacent Cache Prefetch (Available when supported by the CPU)

Select Enable for the CPU to prefetch both cache lines for 128 bytes as comprised. Select Disable for the CPU to prefetch both cache lines for 64 bytes. The options are Disable and **Enable**.

Note: Please power off and reboot the system for the changes you've made to take effect. Please refer to Intel's website for detailed information.

DCU Streamer Prefetcher (Available when supported by the CPU)

If this item is set to Enable, the DCU (Data Cache Unit) streamer prefetcher will prefetch data streams from the cache memory to the DCU (Data Cache Unit) to speed up data accessing and processing for CPU performance enhancement. The options are Disable and **Enable**.

DCU IP Prefetcher

If this item is set to Enable, the IP prefetcher in the DCU (Data Cache Unit) will prefetch IP addresses to improve network connectivity and system performance. The options are **Enable** and Disable.

LLC Prefetch

If this feature is set to Enable, LLC (hardware cache) prefetching on all threads will be supported. The options are **Disable** and Enable.

Extended APIC (Extended Advanced Programmable Interrupt Controller)

Based on the Intel Hyper-Threading technology, each logical processor (thread) is assigned 256 APIC IDs (APIDs) in 8-bit bandwidth. When this feature is set to Enable, the APIC ID will be expanded from 8 bits to 16 bits to provide 512 APIDs to each thread to enhance CPU performance. The options are **Disable** and Enable.

AES-NI

Select Enable to use the Intel Advanced Encryption Standard (AES) New Instructions (NI) to ensure data security. The options are **Enable** and Disable.

►Advanced Power Management Configuration

►CPU P State Control

SpeedStep (PStates)

EIST (Enhanced Intel SpeedStep Technology) allows the system to automatically adjust processor voltage and core frequency in an effort to reduce power consumption and heat dissipation. Please refer to Intel's website for detailed information. The options are Disable and **Enable**.

EIST PSD Function (Available when SpeedStep is set to Enable)

Use this item to configure the processor's P-State coordination settings. During a P-State, the voltage and frequency of the processor will be reduced when it is in operation. This makes the processor more energy efficient, resulting in further energy gains. The options are **HW_ALL**, **SW_ALL** and **SW-ANY**.

Turbo Mode (Available when SpeedStep is set to Enable)

Select Enable for processor cores to run faster than the frequency specified by the manufacturer. The options are Disable and **Enable**.

►Hardware PM (Power Management) State Control

Hardware P-States

If this feature is set to Disable, hardware will choose a P-state setting for the system based on an OS request. If this feature is set to Native Mode, hardware will choose a P-state setting based on OS guidance. If this feature is set to Native Mode with No Legacy Support, hardware will choose a P-state setting independently without OS guidance. The options are **Disable**, Native Mode, Out of Band Mode, and Native Mode with No Legacy Support.

►CPU C State Control

Autonomous Core C-State

Select Enable to support Autonomous Core C-State control which will allow the processor core to control its C-State setting automatically and independently. The options are Enable and **Disable**.

CPU C6 Report

Select Enable to allow the BIOS to report the CPU C6 state (ACPI C3) to the operating system. During the CPU C6 state, power to all caches is turned off. The options are **Auto**, Enable, and Disable.

Enhanced Halt State (C1E)

Select Enable to enable "Enhanced Halt State" support, which will significantly reduce the CPU's power consumption by minimizing CPU's clock cycles and reduce voltage during a "Halt State." The options are Disable and **Enable**.

► Package C State Control

Package C State

Use this feature to set the limit on the C-State package register. The options are C0/1 state, C2 state, C6 (non-Retention) state, C6 (Retention) state, No Limit, and **Auto**.

► Chipset Configuration

Warning: Setting the wrong values in the following sections may cause the system to malfunction.

► North Bridge

This feature allows the user to configure the settings for the Intel North Bridge.

► UPI (Ultra Path Interconnect) Configuration

This section displays the following UPI General Configuration information:

- Number of CPU
- Number of IIO
- Current UPI Link Speed
- Current UPI Link Frequency
- UPI Global MMIO Low Base/Limit
- UPI Global MMIO High Base/Limit
- UPI PCI-E Configuration Base/Size

Degrade Precedence

Use this feature to select the degrading precedence option for Ultra Path Interconnect connections. Select Topology Precedent to degrade UPI features if system options are in conflict. Select Feature Precedent to degrade UPI topology if system options are in conflict. The options are **Topology Precedence** and Feature Precedence.

Link L0p Enable

Select Enable to enable Link L0p. The options are Disable, Enable, and **Auto**.

Link L1 Enable

Select Enable to enable Link L1 (Level 1 link). The options are Disable, Enable, and **Auto**.

IO Directory Cache

Select Enable for the IODC (I/O Directory Cache) to generate snoops instead of generating memory lockups for remote IIO (InvlToM) and/or WCiLF (Cores). Select Auto for the IODC to generate snoops (instead of memory lockups) for WCiLF (Cores). The options are Disable, **Auto**, Enable for Remote InvltoM Hybrid Push, InvltoM AllocFlow, Enable for Remote InvltoM Hybrid AllocNonAlloc, and Enable for Remote InvltoM and Remote WViLF.

Isoc Mode

Select Enable to enable Isochronous support to meet QoS (Quality of Service) requirements. This feature is especially important for Virtualization Technology. The options are Disable, Enable, and **Auto**.

► Memory Configuration

Enforce POR

Select POR to enforce POR restrictions for DDR4 memory frequency and voltage programming. The options are **POR** and Disable.

Memory Frequency

Use this feature to set the maximum memory frequency for onboard memory modules. The options are **Auto**, 1866, 2000, 2133, 2200, 2400, 2600, and 2666.

Data Scrambling for NVDIMM

Select Enable to enable data scrambling for onboard NVDIMM memory to enhance system performance and security. The options are **Auto**, Disable, and Enable.

Data Scrambling for DDR4

Select Enable to enable data scrambling for DDR4 memory to enhance system performance and security. The options are **Auto**, Disable, and Enable.

tCCD_L Relaxation

If this feature is set to Enable, SPD (Serial Presence Detect) will override tCCD_L ("Column to Column Delay-Long", or "Command to Command Delay-Long" on the column side.) If this feature is set to Disable, tCCD_L will be enforced based on the memory frequency. The options are Enable and **Disable**.

Enable ADR

Select Enable for ADR (Automatic Diagnostic Repository) support to enhance memory performance. The options are Enable and **Disable**.

► Memory Topology

This item displays the information of onboard memory modules as detected by the BIOS.

- P1 DIMMA1
- P1 DIMMB1
- P2 DIMMA1
- P2 DIMMB1

► Memory RAS (Reliability_Availability_Serviceability) Configuration

Use this submenu to configure the following Memory RAS settings.

Static Virtual Lockstep Mode

Select Enable to support Static Virtual Lockstep mode to enhance memory performance. The options are Enable and **Disable**.

Mirror Mode

Select Enable to set all 1LM/2LM memory installed in the system on the mirror mode, which will create a duplicate copy of data stored in the memory to increase memory security, but it will reduce the memory capacity into half. The options are Enable and **Disable**.

Memory Rank Sparing

Select Enable to support memory-rank sparing to optimize memory performance. The options are Enable and **Disable**.

Note: This item will not be available when memory mirror mode is enabled.

Memory Correctable Error Threshold

Use this item to enter the threshold value for correctable memory errors. The default setting is 10.

SDDC

Select Enable for SDDC (Single Device Data Correction) support, which will increase the reliability and serviceability of your system memory. The options are Enable and **Disable**.

ADDDC (Adaptive Double Device Data Correction) Sparing

Select Enable for ADDDC sparing support to enhance memory performance. The options are Enable and **Disable**.

Patrol Scrub

Patrol Scrubbing is a process that allows the CPU to correct correctable memory errors detected in a memory module and send the corrections to the requestor (the original source). When this item is set to Enable, the IO hub will read and write back one cache line every 16K cycles if there is no delay caused by internal processing. By using this method,

roughly 64 GB of memory behind the IO hub will be scrubbed every day. The options are **Enable** and **Disable**.

Patrol Scrub Interval

Use this item to specify the number of hours (between 0 to 24) required for the system to complete a full patrol scrubbing. Enter 0 for patrol scrubbing to be performed automatically. The default setting is **24**.

Note: This item is hidden when Patrol Scrub item is set to **Disable**.

► IIO Configuration

EV DFX (Device Function On-Hide) Features

When this feature is set to **Enable**, the EV_DFX Lock Bits that are located in a processor will always remain clear during electric tuning. The options are **Disable** and **Enable**.

► CPU1 Configuration/CPU2 Configuration

IOU0 (IIO PCIe Br1)

This item configures the PCI-E Bifurcation setting for a PCI-E port specified by the user. The options are x4x4x4x4, x4x4x8, x8x4x4, x8x8, x16, and **Auto**.

IOU1 (IIO PCIe Br2)

This item configures the PCI-E Bifurcation setting for a PCI-E port specified by the user. The options are x4x4x4x4, x4x4x8, x8x4x4, x8x8, x16, and **Auto**.

IOU2 (IIO PCIe Br3)

This item configures the PCI-E Bifurcation setting for a PCI-E port specified by the user. The options are x4x4x4x4, x4x4x8, x8x4x4, x8x8, x16, and **Auto**.

MCP0 (IIO PCIe Br4)

This item configures the PCI-E Bifurcation setting for a PCI-E port specified by the user. The options are x16 and **Auto**.

MCP1 (IIO PCIe Br5)

This item configures the PCI-E Bifurcation setting for a PCI-E port specified by the user. The options are x16 and **Auto**.

► Socket 0 PCI-E Br0D00F0 - Port 0/DMI (Available for CPU 1 Configuration only)

Link Speed

This item configures the link speed of a PCI-E port specified by the user. The options are **Auto**, Gen 1 (Generation 1) (2.5 GT/s), Gen 2 (Generation 2) (5 GT/s), and Gen 3 (Generation 3) (8 GT/s)

The following information will be displayed as well:

- PCI-E Port Link Status

- PCI-E Port Link Max
- PCI-E Port Link Speed

PCI-E Port Max (Maximum) Payload Size (Available for CPU 1 Configuration only)

Select Auto for the system BIOS to automatically set the maximum payload value for a PCI-E device specified by to user to enhance system performance. The options are **Auto**, 128B, and 256B.

► IOAT Configuration

Disable TPH (TLP Processing Hint)

TPH is used for data-tagging with a destination ID and a few important attributes. It can send critical data to a particular cache without writing through to memory. Select No in this item for TLP Processing Hint support, which will allow a "TLP request" to provide "hints" to help optimize the processing of each transaction occurred in the target memory space. The options are Yes and **No**.

Prioritize TPH (TLP Processing Hint)

Select Yes to prioritize the TPL requests that will allow the "hints" to be sent to help facilitate and optimize the processing of certain transactions in the system memory. The options are Enable and **Disable**.

Relaxed Ordering

Select Enable to enable Relaxed Ordering support which will allow certain transactions to violate the strict-ordering rules of PCI and to be completed prior to other transactions that have already been enqueued. The options are **Disable** and Enable.

► Intel VT for Directed I/O (VT-d)

Intel VT for Directed I/O (VT-d)

Intel VT for Directed I/O (VT-d)

Select Enable to use Intel Virtualization Technology support for Direct I/O VT-d by reporting the I/O device assignments to the VMM (Virtual Machine Monitor) through the DMAR ACPI tables. This feature offers fully-protected I/O resource sharing across Intel platforms, providing greater reliability, security and availability in networking and data-sharing. The options are **Enable** and Disable.

Interrupt Remapping

Select Enable for Interrupt Remapping support to enhance system performance. The options are **Enable** and Disable.

PassThrough DMA

Select Enable for the Non-IscoH VT-d engine to pass through DMA (Direct Memory Access) to enhance system performance. The options are **Enable** and Disable.

ATS

Select Enable to enable ATS (Address Translation Services) support for the Non-IscoH VT-d engine to enhance system performance. The options are **Enable** and Disable.

Posted Interrupt

Select Enable to support VT_D Posted Interrupt which will allow external interrupts to be sent directly from a direct-assigned device to a client machine in non-root mode to improve virtualization efficiency by simplifying interrupt migration and lessening the need of physical interrupts. The options are **Enable** and Disable.

Coherency Support (Non-IscoH)

Select Enable for the Non-IscoH VT-d engine to pass through DMA (Direct Memory Access) to enhance system performance. The options are **Enable** and Disable.

► Intel VMD Technology

► Intel VMD for Onboard NVMe

VMD Configuration Onboard NVMe

Onboard NVMe Mode

Select Legacy Mode for the onboard NVMe devices to support Legacy Mode. The options are **Legacy Mode** and the VMD Mode.

IIO-PCIE Express Global Options

The section allows the user to configure the following PCI-E global options:

PCE-E Hot Plug

Select Enable to support Hot-plugging for the selected PCI-E slots which will allow the user to replace the devices installed in the slots without shutting down the system. The options are **Enable** and Disabled.

PCI-E Completion Timeout (Global)

Use this item to select the PCI-E Completion Time-out settings. The options are **Yes**, No, and Per-Port.

► South Bridge

The following South Bridge information will display:

- USB Module Version
- USB Devices

Legacy USB Support

Select Enabled to support onboard legacy USB devices. Select Auto to disable legacy support if there are no legacy USB devices present. Select Disabled to have all USB devices available for EFI applications only. The options are **Enabled**, Disabled and Auto.

XHCI Hand-Off

This is a work-around solution for operating systems that do not support XHCI (Extensible Host Controller Interface) hand-off. The XHCI ownership change should be claimed by the XHCI driver. The options are Enabled and **Disabled**.

Port 60/64 Emulation

Select Enabled for I/O port 60h/64h emulation support, which in turn, will provide complete legacy USB keyboard support for the operating systems that do not support legacy USB devices. The options are **Enabled** and Disabled.

Port 61h Bit-4 Emulation

Select Enabled for I/O Port 61h-Bit 4 emulation support to enhance system performance. The options are Enabled and **Disabled**.

Install Windows 7 USB Support

Select Enabled to install the Windows 7 USB utility to support legacy USB devices for Windows 7 systems. The options are Enabled and **Disabled**.

► Server ME (Management Engine) Configuration

This feature displays the following system ME configuration settings.

Operational Firmware Version

Backup Firmware Version

Recovery Firmware Version

ME Firmware Status #1

ME Firmware Status #2

 Current State

 Error Code

►SATA Configuration

When this submenu is selected, the AMI BIOS automatically detects the presence of the SATA devices that are supported by the Intel PCH chip and displays the following items:

SATA Controller

This item enables or disables the onboard SATA controller supported by the Intel PCH chip. The options are **Enable** and **Disable**.

Configure SATA as (Available when the item above: SATA Controller is set to enabled)

Select AHCI to configure a SATA drive specified by the user as an AHCI drive. Select RAID to configure a SATA drive specified by the user as a RAID drive. The options are **AHCI** and **RAID**. (**Note:** This item is hidden when the SATA Controller item is set to Disabled.)

SATA HDD Unlock

Select Enable to unlock SATA HDD password in the OS. The options are **Enable** and **Disable**.

SATA/sSATA RAID Boot Select (Available when the item "Configure SATA as" is set to "RAID")

This feature allows the user to decide which controller should be used for system boot. The options are None, SATA Controller, **sSATA Controller**, and Both.

Aggressive Link Power Management

When this item is set to Enabled, the SATA AHCI controller manages the power use of the SATA link. The controller will put the link in a low power mode during an extended period of I/O inactivity, and will return the link to an active state when I/O activity resumes. The options are Enable and **Disable**.

SATA RAID Option ROM/UEFI Driver (Available when the item "Configure SATA as" is set to "RAID")

Select EFI to load the EFI driver for system boot. Select Legacy to load a legacy driver for system boot. The options are Disable, EFI, and **Legacy**.

SATA Port 0 - SATA Port 7

Hot Plug

Select Enable to support Hot-plugging for the device installed on a selected SATA port which will allow the user to replace the device installed in the slot without shutting down the system. The options are Enable and **Disabled**.

Spin Up Device

On an edge detect from 0 to 1, set this item to allow the SATA device installed on the SATA port specified by the user to start a COMRESET initialization. The options are Enable and **Disable**.

SATA Device Type

Use this item to specify if the device installed on the SATA port selected by the user should be connected to a Solid State drive or a Hard Disk Drive. The options are **Hard Disk Drive** and Solid State Drive.

►sSATA Configuration

When this submenu is selected, AMI BIOS automatically detects the presence of the sSATA devices that are supported by the sSATA controller and displays the following items:

sSATA Controller

This item enables or disables the onboard sSATA controller supported by the Intel SCU. The options are **Enable** and Disable.

Configure sSATA as

Select AHCI to configure an sSATA drive specified by the user as an AHCI drive. Select RAID to configure an sSATA drive specified by the user as a RAID drive. The options are **AHCI** and RAID. (**Note:** This item is hidden when the sSATA Controller item is set to Disabled.)

SATA HDD Unlock

Select Enable to unlock sSATA HDD password in the OS. The options are **Enable** and Disable.

SATA/sSATA RAID Boot Select (Available when the item "Configure SATA as" is set to "RAID")

This feature allows the user to decide which controller should be used for system boot. The options are None, SATA Controller, **sSATA Controller**, and Both.

Support Aggressive Link Power Management

When this item is set to Enable, the sSATA AHCI controller manages the power use of the SATA link. The controller will put the link in a low power mode during an extended period of I/O inactivity, and will return the link to an active state when I/O activity resumes. The options are **Disable** and Enable.

sSATA RAID Option ROM/UEFI Driver (Available when the item "Configure SATA as" is set to "RAID")

Select EFI to load the EFI driver for system boot. Select Legacy to load a legacy driver for system boot. The options are Disable, EFI, and **Legacy**.

sSATA Port 0 - sSATA Port 5

Hot Plug

Select Enable to support Hot-plugging for the device installed on an sSATA port selected by the user which will allow the user to replace the device installed in the slot without shutting down the system. The options are **Disable** and Enabled.

Spin Up Device

On an edge detect from 0 to 1, set this item to allow the sSATA device installed on the sSATA port specified by the user to start a COMRESET initialization. The options are Enable and **Disable**.

sSATA Device Type

Use this item to specify if the device installed on the sSATA port specified by the user should be connected to a Solid State drive or a Hard Disk Drive. The options are **Hard Disk Drive** and Solid State Drive.

►PCIe/PCI/PnP Configuration

The following PCI information will be displayed:

- PCI Bus Driver Version
- PCI Devices Common Settings:

Above 4G Decoding (Available if the system supports 64-bit PCI decoding)

Select Enabled to decode a PCI device that supports 64-bit in the space above 4G Address. The options are **Enabled** and Disabled.

SR-IOV Support (Available if the system supports Single-Root Virtualization)

Select Enabled for Single-Root IO Virtualization support. The options are Enabled and **Disabled**.

MMIOHBase

Use this item to select the base memory size according to memory-address mapping for the IO hub. The base memory size must be between 4032G to 4078G. The options are **56T**, 48T, 24T, 16T, 4T, and 1T.

MMIO High Granularity Size

Use this item to select the high memory size according to memory-address mapping for the IO hub. The options are 1G, 4G, 16G, 64G, **256G**, and 1024G.

PCI PERR/SERR Support

Use this feature to enable or disable the runtime event for SERR (System Error)/ PERR (PCI/PCI-E Parity Error). The options are Disabled and **Enabled**.

Maximum Read Request

Select Auto for the system BIOS to automatically set the maximum size for a read request for a PCI-E device to enhance system performance. The options are **Auto**, 128 Bytes, 256 Bytes, 512 Bytes, 1024 Bytes, 2048 Bytes, and 4096 Bytes.

MMCFG Base

This feature determines the lowest MMCFG (Memory-Mapped Configuration) base assigned to PCI devices. The options are 1G, 1.5G, 1.75G, **2G**, 2.25G, and 3G.

VGA Priority

Use this item to select the graphics device to be used as the primary video display for system boot. The options are Auto, **Onboard** and Offboard.

PCI Devices Option ROM Settings

Onboard NVME1/NVME2 OPROM

Select EFI to allow the user to boot the computer using an EFI (Expansible Firmware Interface) device installed on the NVME connector specified by the user. Select Legacy to allow the user to boot the computer using a legacy device installed on the NVME connector specified by the user. The options are Disabled, Legacy and **EFI**.

CPU1 Slot 1 PCI-E x8 OPROM/CPU1 Slot 2 PCI-E x16 OPROM/CPU1 Slot 3 PCI-E x8 OPROM/CPU2 Slot 4 PCI-E x16 OPROM/CPU2 Slot 5 PCI-E x16 OPROM/CPU2 Slot 6 PCI-E x16 OPROM/

Select EFI to allow the user to boot the computer using an EFI (Expansible Firmware Interface) device installed on the PCI-E slot specified by the user. Select Legacy to allow the user to boot the computer using a legacy device installed on the PCI-E slot specified by the user. The options are Disabled, **Legacy** and EFI. (**Note:** Riser card names may differ in each system.)

Onboard Video Option ROM

Use this feature to select the Onboard Video Option ROM type. The options are Disabled, **Legacy** and EFI.

Onboard LAN1 Option ROM

Use this feature to select the type of device installed in LAN Port1 used for system boot. The options are **Legacy**, EFI and Disabled.

Onboard LAN2 Option ROM

Use this feature to select the type of device installed in LAN Port2 used for system boot. The options are Legacy, EFI and **Disabled**.

► Network Stack Configuration

Network Stack

Select Enabled to enable PXE (Preboot Execution Environment) or UEFI (Unified Extensible Firmware Interface) for network stack support. The options are **Enabled** and Disabled.

****If "Network Stack" is set to Enabled, the following items will display:***

Ipv4 PXE Support

Select Enabled to enable Ipv4 PXE boot support. If this feature is disabled, it will not create the Ipv4 PXE boot option. The options are Disabled and **Enabled**.

Ipv4 HTTP Support

Select Enabled to enable Ipv4 HTTP boot support. If this feature is disabled, it will not create the Ipv4 HTTP boot option. The options are Enabled and **Disabled**.

Ipv6 PXE Support

Select Enabled to enable Ipv6 PXE boot support. If this feature is disabled, it will not create the Ipv6 PXE boot option. The options are Disabled and **Enabled**.

Ipv6 HTTP Support

Select Enabled to enable Ipv6 HTTP boot support. If this feature is disabled, it will not create the Ipv6 HTTP boot option. The options are Enabled and **Disabled**.

PXE Boot Wait Time

Use this feature to select the wait time to press the <ESC> key to abort the PXE boot. The default is 0.

Media Detect Time

Use this feature to select the wait time in seconds for the BIOS ROM to detect the LAN media (Internet connection or LAN port). The default is 1.

► Super IO Configuration

Super IO Chip AST2500

► Serial Port 1 Configuration

Serial Port

Select Enabled to enable the onboard serial port specified by the user. The options are **Enabled** and Disabled.

Device Settings

This item displays the base I/O port address and the Interrupt Request address of a serial port specified by the user.

Note: This item is hidden when Serial Port 1 is set to Disabled.

Change Settings

This feature specifies the base I/O port address and the Interrupt Request address of Serial Port 1. Select **Auto** for the BIOS to automatically assign the base I/O and IRQ address to a serial port specified.

The options for Serial Port 1 are **Auto**, (IO=3F8h; IRQ=4), (IO=3F8h; IRQ=3, 4, 5, 6, 7, 9, 10, 11, 12), (IO=2F8h; IRQ=3, 4, 5, 6, 7, 9, 10, 11, 12); (IO=3E8h; IRQ=3, 4, 5, 6, 7, 9, 10, 11, 12), and (IO=2E8h; IRQ=3, 4, 5, 6, 7, 9, 10, 11, 12).

► Serial Port 2 Configuration

Serial Port

Select Enabled to enable the onboard serial port specified by the user. The options are **Enabled** and Disabled.

Device Settings

This item displays the base I/O port address and the Interrupt Request address of a serial port specified by the user.

Note: This item is hidden when Serial Port 1 is set to Disabled.

Change Settings

This feature specifies the base I/O port address and the Interrupt Request address of Serial Port 2. Select Auto for the BIOS to automatically assign the base I/O and IRQ address to a serial port specified. The options for Serial Port 2 are **Auto**, (IO=2F8h; IRQ=3), (IO=3F8h; IRQ=3, 4, 5, 6, 7, 9, 10, 11, 12), (IO=2F8h; IRQ=3, 4, 5, 6, 7, 9, 10, 11, 12); (IO=3E8h; IRQ=3, 4, 5, 6, 7, 9, 10, 11, 12), and (IO=2E8h; IRQ=3, 4, 5, 6, 7, 9, 10, 11, 12).

Serial Port 2 Attribute

Select SOL to use COM Port 2 as a Serial_Over_LAN (SOL) port for console redirection. The options are COM and **SOL**.

► Serial Port Console Redirection

COM 1 Console Redirection

Select Enabled to enable COM Port 1 for Console Redirection, which will allow a client machine to be connected to a host machine at a remote site for networking. The options are Enabled and **Disabled**.

**If the item above set to Enabled, the following items will become available for configuration:*

► Console Redirection Settings (for COM1)

Terminal Type

Use this feature to select the target terminal emulation type for Console Redirection. Select VT100 to use the ASCII Character set. Select VT100+ to add color and function key support. Select ANSI to use the Extended ASCII Character Set. Select VT-UTF8 to use UTF8 encoding to map Unicode characters into one or more bytes. The options are ANSI, VT100, **VT100+**, and VT-UTF8.

Bits Per second

Use this feature to set the transmission speed for a serial port used in Console Redirection. Make sure that the same speed is used in the host computer and the client computer. A lower transmission speed may be required for long and busy lines. The options are 9600, 19200, 38400, 57600 and **115200** (bits per second).

Data Bits

Use this feature to set the data transmission size for Console Redirection. The options are 7 (Bits) and **8 (Bits)**.

Parity

A parity bit can be sent along with regular data bits to detect data transmission errors. Select Even if the parity bit is set to 0, and the number of 1's in data bits is even. Select Odd if the parity bit is set to 0, and the number of 1's in data bits is odd. Select None if you do not want to send a parity bit with your data bits in transmission. Select Mark to add a mark as a parity bit to be sent along with the data bits. Select Space to add a Space as a parity bit to be sent with your data bits. The options are **None**, Even, Odd, Mark and Space.

Stop Bits

A stop bit indicates the end of a serial data packet. Select 1 Stop Bit for standard serial data communication. Select 2 Stop Bits if slower devices are used. The options are **1** and 2.

Flow Control

Use this feature to set the flow control for Console Redirection to prevent data loss caused by buffer overflow. Send a "Stop" signal to stop sending data when the receiving buffer is full. Send a "Start" signal to start sending data when the receiving buffer is empty. The options are **None** and Hardware RTS/CTS.

VT-UTF8 Combo Key Support

Select Enabled to enable VT-UTF8 Combination Key support for ANSI/VT100 terminals. The options are **Enabled** and Disabled.

Recorder Mode

Select Enabled to capture the data displayed on a terminal and send it as text messages to a remote server. The options are **Disabled** and Enabled.

Resolution 100x31

Select Enabled for extended-terminal resolution support. The options are Disabled and **Enabled**.

Legacy OS Redirection Resolution

Use this feature to select the number of rows and columns used in Console Redirection for legacy OS support. The options are **80x24** and 80x25.

Putty KeyPad

This feature selects Function Keys and KeyPad settings for Putty, which is a terminal emulator designed for the Windows OS. The options are **VT100**, LINUX, XTERMR6, SCO, ESCN, and VT400.

Redirection After BIOS Post

Use this feature to enable or disable legacy Console Redirection after BIOS POST. When the option-Bootloader is selected, legacy Console Redirection is disabled before booting the OS. When the option-Always Enable is selected, legacy Console Redirection remains enabled upon OS bootup. The options are **Always Enable** and Bootloader.

SOL (Serial-Over-LAN)/COM2

Console Redirection (for SOL/COM2)

Select Enabled to use the SOL port for Console Redirection. The options are **Enabled** and Disabled.

**If the item above set to Enabled, the following items will become available for user's configuration:*

► Console Redirection Settings (for SOL/COM2)

Use this feature to specify how the host computer will exchange data with the client computer, which is the remote computer used by the user.

Terminal Type

Use this feature to select the target terminal emulation type for Console Redirection. Select VT100 to use the ASCII Character set. Select VT100+ to add color and function key support. Select ANSI to use the Extended ASCII Character Set. Select VT-UTF8 to use UTF8 encoding to map Unicode characters into one or more bytes. The options are ANSI, VT100, **VT100+**, and VT-UTF8.

Bits Per second

Use this feature to set the transmission speed for a serial port used in Console Redirection. Make sure that the same speed is used in the host computer and the client computer. A lower transmission speed may be required for long and busy lines. The options are 9600, 19200, 38400, 57600 and **115200** (bits per second).

Data Bits

Use this feature to set the data transmission size for Console Redirection. The options are 7 (Bits) and **8 (Bits)**.

Parity

A parity bit can be sent along with regular data bits to detect data transmission errors. Select Even if the parity bit is set to 0, and the number of 1's in data bits is even. Select

Odd if the parity bit is set to 0, and the number of 1's in data bits is odd. Select None if you do not want to send a parity bit with your data bits in transmission. Select Mark to add a mark as a parity bit to be sent along with the data bits. Select Space to add a Space as a parity bit to be sent with your data bits. The options are **None**, Even, Odd, Mark and Space.

Stop Bits

A stop bit indicates the end of a serial data packet. Select 1 Stop Bit for standard serial data communication. Select 2 Stop Bits if slower devices are used. The options are **1** and **2**.

Flow Control

Use this feature to set the flow control for Console Redirection to prevent data loss caused by buffer overflow. Send a "Stop" signal to stop sending data when the receiving buffer is full. Send a "Start" signal to start data-sending when the receiving buffer is empty. The options are **None** and Hardware RTS/CTS.

VT-UTF8 Combo Key Support

Select Enabled to enable VT-UTF8 Combination Key support for ANSI/VT100 terminals. The options are **Enabled** and Disabled.

Recorder Mode

Select Enabled to capture the data displayed on a terminal and send it as text messages to a remote server. The options are **Disabled** and Enabled.

Resolution 100x31

Select Enabled for extended-terminal resolution support. The options are Disabled and **Enabled**.

Legacy OS Redirection Resolution

Use this feature to select the number of rows and columns used in Console Redirection for legacy OS support. The options are **80x24** and 80x25.

Putty KeyPad

This feature selects Function Keys and KeyPad settings for Putty, which is a terminal emulator designed for the Windows OS. The options are **VT100**, LINUX, XTERMR6, SCO, ESCN, and VT400.

Redirection After BIOS Post

Use this feature to enable or disable legacy Console Redirection after BIOS POST (Power-On Self-Test). When this feature is set to Bootloader, legacy Console Redirection is disabled before booting the OS. When this feature is set to Always Enable, legacy Console Redirection remains enabled upon OS boot. The options are **Always Enable** and Bootloader.

► Legacy Console Redirection Settings

Legacy Console Redirection Settings

Use the feature to select the COM port to display redirection of Legacy OS and Legacy OPRM messages. The default setting is **COM1**.

Serial Port for Out-of-Band Management/Windows Emergency Management Services (EMS)

The submenu allows the user to configure Console Redirection settings to support Out-of-Band Serial Port management.

Console Redirection (for EMS)

Select Enabled to use a COM port selected by the user for EMS Console Redirection. The options are **Disabled** and Enabled.

**If the item above set to Enabled, the following items will become available for user's configuration:*

► EMS Console Redirection Settings

Out-of-Band Management Port

The feature selects a serial port in a client server to be used by the Windows Emergency Management Services (EMS) to communicate with a remote host server. The options are **COM1 (Console Redirection)** and COM2/SOL (Console Redirection).

Terminal Type

Use this feature to select the target terminal emulation type for Console Redirection. Select VT100 to use the ASCII character set. Select VT100+ to add color and function key support. Select ANSI to use the extended ASCII character set. Select VT-UTF8 to use UTF8 encoding to map Unicode characters into one or more bytes. The options are ANSI, VT100, VT100+, and **VT-UTF8**.

Bits Per Second

This feature sets the transmission speed for a serial port used in Console Redirection. Make sure that the same speed is used in both host computer and the client computer. A lower transmission speed may be required for long and busy lines. The options are 9600, 19200, 57600, and **115200** (bits per second).

Flow Control

Use this feature to set the flow control for Console Redirection to prevent data loss caused by buffer overflow. Send a "Stop" signal to stop data-sending when the receiving buffer is full. Send a "Start" signal to start data-sending when the receiving buffer is empty. The options are **None**, Hardware RTS/CTS, and Software Xon/Xoff.

The setting for each these features is displayed:

Data Bits, Parity, Stop Bits

►ACPI Settings

Use this feature to configure Advanced Configuration and Power Interface (ACPI) power management settings for your system.

NUMA Support (Available when the OS supports this feature)

Select Enabled to enable Non-Uniform Memory Access support to enhance system performance. The options are **Enabled** and Disabled.

WHEA Support

Select Enabled to support the Windows Hardware Error Architecture (WHEA) platform and provide a common infrastructure for the system to handle hardware errors within the Windows OS environment to reduce system crashes and to enhance system recovery and health monitoring. The options are **Enabled** and Disabled.

High Precision Timer

Select Enabled to activate the High Precision Event Timer (HPET) that produces periodic interrupts at a much higher frequency than a Real-time Clock (RTC) does in synchronizing multimedia streams, providing smooth playback and reducing the dependency on other timestamp calculation devices, such as an x86 RDTSC Instruction embedded in the CPU. The High Performance Event Timer is used to replace the 8254 Programmable Interval Timer. The options are **Enabled** and Disabled.

►Trusted Computing (Available when a TPM device is installed and detected by the BIOS)

When a TPM (Trusted-Platform Module) device is detected in your machine, the following information will be displayed.

- TPM2.0 Device Found
- Vendor
- Firmware Version

Security Device Support

If this feature and the TPM jumper (JPT1) on the motherboard are both enabled, the onboard security (TPM) device will be enabled in the BIOS to enhance data integrity and system security. Please note that the OS will not show the security device. Neither TCG EFI protocol nor INT1A interaction will be made available for use. If you have made changes on the setting on this item, be sure to reboot the system for the change to take effect. The options are Disable and **Enable**. If this option is set to Enable, the following screen and items will display:

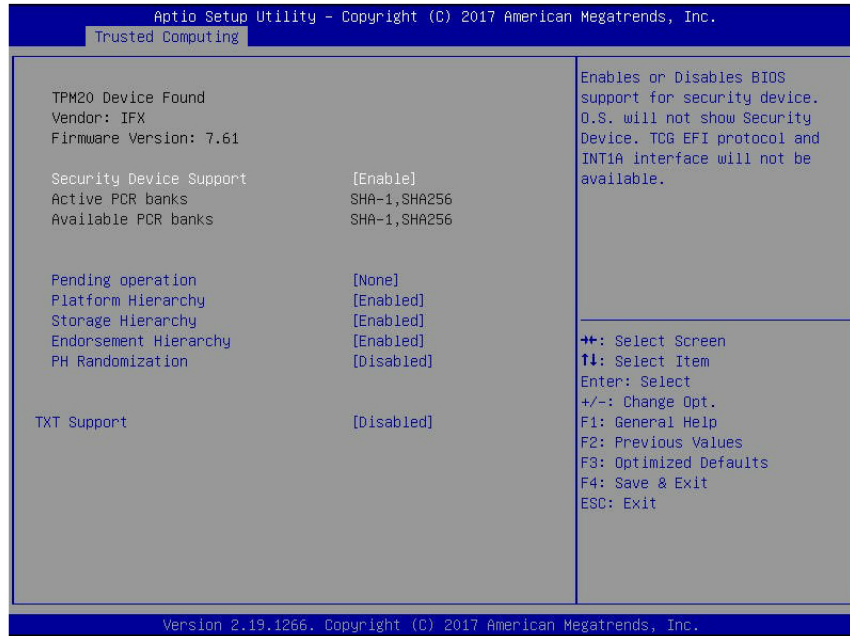

- Active PCR Banks
- Available PCR Banks

Pending Operation

Use this feature to schedule a TPM-related operation to be performed by a security (TPM) device at the next system boot to enhance system data integrity. Your system will reboot to carry out a pending TPM operation. The options are **None** and TPM Clear.

Note: Your system will reboot to carry out a pending TPM operation.

Platform Hierarchy (for TPM Version 2.0 and above)

Select Enabled for TPM Platform Hierarchy support which will allow the manufacturer to utilize the cryptographic algorithm to define a constant key or a fixed set of keys to be used for initial system boot. This early boot code is shipped with the platform and is included in the list of "public keys". During system boot, the platform firmware uses this trusted public key to verify a digital signature in an attempt to manage and control the security of the platform firmware used in a host system via a TPM device. The options are **Enabled** and Disabled.

Storage Hierarchy

Select Enabled for TPM Storage Hierarchy support that is intended to be used for non-privacy-sensitive operations by the platform owner such as an IT professional or the end user. Storage Hierarchy has an owner policy and an authorization value, both of which can be set and are held constant (-rarely changed) through reboots. This hierarchy can be cleared or changed independently of the other hierarchies. The options are **Enabled** and Disabled.

Endorsement Hierarchy

Select Enabled for Endorsement Hierarchy support, which contains separate controls to address the user's privacy concerns because the primary keys in this hierarchy are certified by the TPM or a manufacturer to be constrained to an authentic TPM device that is attached to an authentic platform. A primary key can be an encrypted, and a certificate can be created using TPM2_ActivateCredential. It allows the user to independently enable "flag, policy, and authorization value" without involving other hierarchies. A user with privacy concerns can disable the endorsement hierarchy while still using the storage hierarchy for TPM applications and permitting the platform software to use the TPM. The options are **Enabled** and Disabled.

PH (Platform Hierarchy) Randomization (for TPM Version 2.0 and above)

Select Enabled for Platform Hierarchy Randomization support, which is used only during the platform developmental stage. This feature cannot be enabled in the production platforms. The options are **Disabled** and Enabled.

TXT Support

Select Enabled to enable Intel Trusted Execution Technology (TXT) support to enhance system security and data integrity. The options are **Disabled** and Enabled.

Note 1: If the option for this item (TXT Support) is set to Enabled, be sure to disable EV DFX (Device Function On-Hide) support for the system to work properly. (EV DFX is under "IIO Configuration" in the "Chipset/North Bridge" submenu).

Note 2: For more information on TPM, please refer to the TPM manual at <http://www.supermicro.com/manuals/other>.

► Intel Virtual RAID on CPU

When this submenu is selected and the RAID devices are detected, the BIOS screen displays the following items:

Intel VROC with VMD Technology 5.0.0.1205

6.4 Event Logs

Use this tab page to configure Event Log settings.



▶ Change SMBIOS Event Log Settings

Enabling/Disabling Options

SMBIOS Event Log

Select Enabled to enable SMBIOS (System Management BIOS) Event Logging during system boot. The options are **Enabled** and Disabled.

Erasing Settings

Erase Event Log

Select Enabled to erase all error events in the SMBIOS (System Management BIOS) log before an event logging is initialized at bootup. The options are **No**, Yes, Next Reset, and Yes, Next Reset.

When Log is Full

Select Erase Immediately to immediately erase all errors in the SMBIOS event log when the event log is full. Select Do Nothing for the system to do nothing when the SMBIOS event log is full. The options are **Do Nothing** and Erase Immediately.

SMBIOS Event Log Standard Settings

Log System Boot Event

Select Enabled to log system boot events. The options are Enabled and **Disabled**.

MECI (Multiple Event Count Increment)

Enter the increment value for the multiple event counter. Enter a number between 1 to 255. The default setting is 1.

METW (Multiple Event Count Time Window)

This item is used to determine how long (in minutes) should the multiple event counter wait before generating a new event log. Enter a number between 0 to 99. The default setting is **60**.

Note: Please reboot the system for the changes to take effect.

Customer Options

Log OEM Codes

Select Enabled to log the EFI Status codes as OEM codes if these codes have not been converted to Legacy. The options are **Enabled** and Disabled.

Convert OEM Codes

Select Enabled to convert the EFI Status codes to standard SMBIOS codes. Please note that this option is not available for all EFI Status codes. The options are Enabled and **Disabled**.

Note: Please reboot the system for the changes to take effect.

►View System Event Log

This item allows the user to view the event in the system event log. Select this item and press <Enter> to view the status of an event in the log. The following categories are displayed:

Date/Time/Error Code/Severity

6.5 IPMI

Use this tab page to configure Intelligent Platform Management Interface (IPMI) settings.

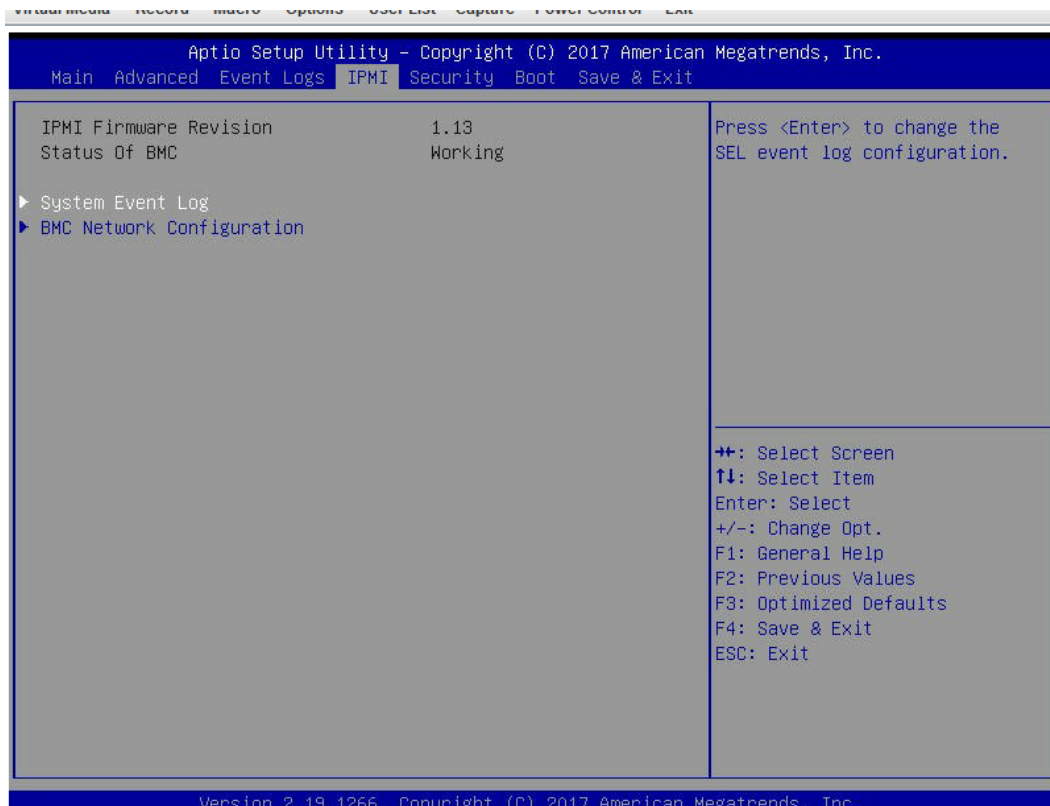

The following items will be displayed:

- IPMI Firmware Revision
- Status of BMC

► System Event Log

Enabling/Disabling Options

SEL Components

Select Enabled for all system event logging at bootup. The options are **Enabled** and Disabled.

Erasing Settings

Erase SEL

Select Yes, On next reset to erase all system event logs upon next system reboot. Select Yes, On every reset to erase all system event logs upon each system reboot. Select No to keep all system event logs after each system reboot. The options are **No**, Yes, On next reset, and Yes, On every reset.

When SEL is Full

This feature allows the user to determine what the BIOS should do when the system event log is full. Select Erase Immediately to erase all events in the log when the system event log is full. The options are **Do Nothing** and Erase Immediately.

Custom EFI Logging Options

Log EFI Status Codes

Select EFI (Extensible Firmware Interface) Status Codes to log EFI status codes. Select Error Codes to log EFI error codes. Select Progress Code to log the EFI progress code. Select both to log both EFI error codes and progress codes. The options are Disabled, Both, **Error code** and Progress code.

Note: After making changes on a setting, be sure to reboot the system for the changes to take effect.

► BMC Network Configuration

The following items will be displayed:

- IPMI LAN Selection: This item displays the IPMI LAN setting. The default setting is **Failover**.
- IPMI Network Link Status: This item displays the IPMI Network Link status. The default setting is **Shared LAN**.
- Current Configuration Address Source: This item displays the source of the current IPMI LAN address. The default setting is **CHCP (Dynamic Host Configuration Protocol)**.
- Station IP Address: This item displays the Station IP address for this computer. This should be in decimal and in dotted quad form (i.e., 192.168.10.253).
- Subnet Mask: This item displays the sub-network that this computer belongs to. The value of each three-digit number separated by dots should not exceed 255.
- Station MAC Address: This item displays the Station MAC address for this computer. Mac addresses are 6 two-digit hexadecimal numbers.
- Gateway IP Address: This item displays the Gateway IP address for this computer. This should be in decimal and in dotted quad form (i.e., 192.168.10.253).
- VLAN: This item displays the status of VLAN support.

Update IPMI LAN Configuration

Select Yes for the BIOS to implement all IP/MAC address changes at the next system boot. The options are **No** and Yes. If this option is set to Yes, the following items will display:

IPMI LAN Selection

Use this feature to select the type of the IPMI LAN. The options are Dedicated, Shared, and **Failover**.

VLAN

Select Enabled to enable IPMI VLAN function support. The options are **Enabled** and Disabled.

Configuration Address Source

Use this item to select the IP address source for this computer. If Static is selected, you will need to know the IP address of this computer and enter it to the system manually in the field. If DHCP is selected, AMI BIOS will search for a DHCP (Dynamic Host Configuration Protocol) server attached to the network and request the next available IP address for this computer. The options are **DHCP** and Static.

6.6 Security

Use this tab page to configure Security settings.

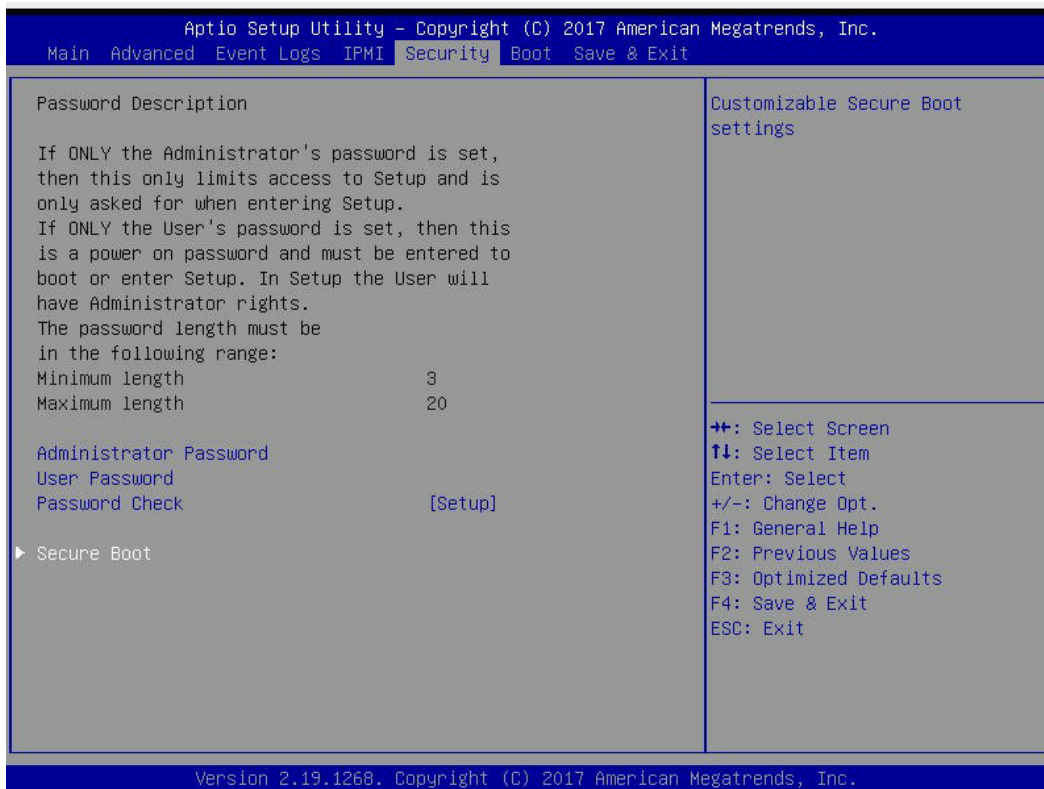

Administrator Password

Use this feature to set the administrator password which is required to enter the BIOS setup utility. The length of the password should be from 3 characters to 20 characters long.

User Password

Use this feature to set the user password which is required to enter the BIOS setup utility. The length of the password should be from 3 characters to 20 characters long.

Password Check

Select Setup for the system to check for a password at Setup. Select Always for the system to check for a password at bootup or upon entering the BIOS Setup utility. The options are **Setup** and **Always**.

►Secure Boot

When you select this submenu and press the <Enter> key, the following items will display:

- System Mode
- Secure Boot
- Vendor Keys

Attempt Secure Boot

If this item is set to Enabled, Secure Boot will be activated when a Platform Key (PK) is entered. A Platform Key is a security key used to manage the security settings of the platform firmware used in your system. The options are Enabled and **Disabled**.

Secure Boot Mode

Use this feature to select the desired secure boot mode for the system. The options are Standard and **Custom**.

►Key Management

Provision Factory Default Keys

Select Enabled to install all manufacturer default keys for the following system security settings. The options are Enabled and **Disabled**.

►Install Factor Default Keys

Select Yes to install all manufacturer defaults for the following system security settings. The options are **Yes** and No.

►Enroll EFI Image

Select this item and press <Enter> to select an EFI (Extensible Firmware Interface) image for the system to operate in Secure Boot mode.

► Save All Secure Boot Variables

This feature allows the user to set and save the secure boot key variables specified by the user.

Secure Boot Variables

Secure Boot Variable/Size/Key#/Key Sources

► Platform Key (PK)

This feature allows the user to enter and configure a set of values to be used as a platform firmware key for the system. This set of values also indicate the size, the keys numbers, and the key source of the Platform Key. The options are **Save to File**, Set New, and Erase.

► Key Exchange Keys

This feature allows the user to enter and configure a set of values to be used as a Key-Exchange-Keys for the system. This set of values also indicate the size, the keys numbers, and the key source of the Key-Exchange-Keys. The options are **Save to File**, Set New, and Erase.

► Authorized Signatures

This feature allows the user to enter and configure a set of values to be used as Authorized Signatures for the system. This set of values also indicate the size, the keys numbers, and the key source of the Authorized Signatures. The options are **Set New** and Append.

Secure Boot Variable/Size/Key#/Key Sources The options are **Save to File**, Set New, and Erase.

► Forbidden Signatures

This feature allows the user to enter and configure a set of values to be used as Forbidden Signatures for the system. This set of values also indicate the size, the keys numbers, and the key source of the Forbidden Signatures. The options are **Save to File**, Set New, and Erase.

► Authorized TimeStamps

This feature allows the user to set and save the timestamps for Authorized Signatures to indicate when these signatures were entered into the system. The options are **Save to File**, Set New, and Erase.

► OsRecovery Signatures

This feature allows the user to set and save the Authorized Signatures used for OS recovery. The options are **Save to File**, Set New, and Erase.

6.7 Boot

Use this tab page to configure Boot Settings.

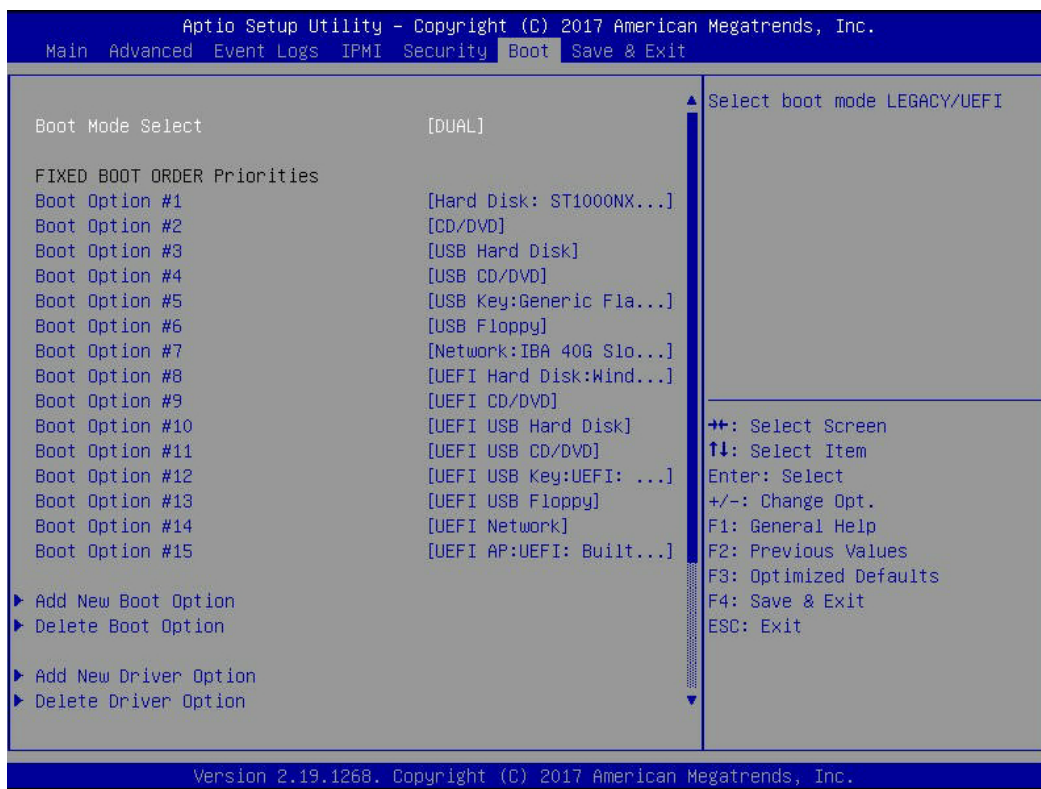

Boot Mode Select

Use this feature to select the type of devices that the system is going to boot from. The options are Legacy, UEFI (Unified Extensible Firmware Interface), and **Dual**.

Fixed Boot Order Priorities

This feature prioritizes the order of a bootable device from which the system will boot. Press <Enter> on each entry from top to bottom to select devices.

When the item above -"Boot Mode Select" is set to **Dual** (default), the following items will be displayed for configuration:

- Boot Option #1 - Boot Option #15

When the item above -"Boot Mode Select" is set to Legacy, the following items will be display for configuration:

- Boot Option #1 - Boot Option #7

When the item above -"Boot Mode Select" is set to UEFI, the following items will be display for configuration:

- Boot Option #1 - Boot Option #8

Add New Boot Option

This feature allows the user to add a new boot option to the boot priority features for your system.

Add Boot Option

Use this item to specify the name for the new boot option.

Path for Boot Option

Use this feature to enter the path for the new boot option in the format fsx:\path\filename.efi.

Boot Option File Path

Use this feature to specify the file path for the new boot option.

Create

After the name and the file path for the boot option are set, press <Enter> to create the new boot option in the boot priority list.

► Delete Boot Option

Use this feature to select a boot device to delete from the boot priority list.

Delete Boot Option

Use this feature to remove an EFI boot option from the boot priority list.

► Add New Driver Option

Use this feature to select a new driver to add to the boot priority list.

Add Driver Option

Use this feature to specify the name of the driver that the new boot option is added to.

Path for Drover Option

Use this feature to specify the path to the driver that the new boot option is added to.

Driver Option File Path

Use this feature to specify the file path of the driver that the new boot option is added to.

Create

After the driver option name and the file path are set, press <Enter> to enter to submenu and click OK to create the new boot option drive.

► Delete Driver Option

Use this item to select a boot driver to delete from the boot priority list.

Delete Drive Option

Select the target boot driver to delete from the boot priority list.

▶ Hard Disk Drive BBS Priorities

- Boot Option #1 - #5

▶ Network Drive BBS Priorities

- Boot Option #1

▶ USB Key Drive BBS Priorities

- Boot Option #1

▶ UEFI Hard Disk Drive BBS Priorities

- Boot Option #1

▶ UEFI USB Key Drive BBS Priorities

- Boot Option #1

▶ UEFI Application Boot Priorities

- Boot Option #1

6.8 Save & Exit

Use this tab page to configure Save & Exit settings.

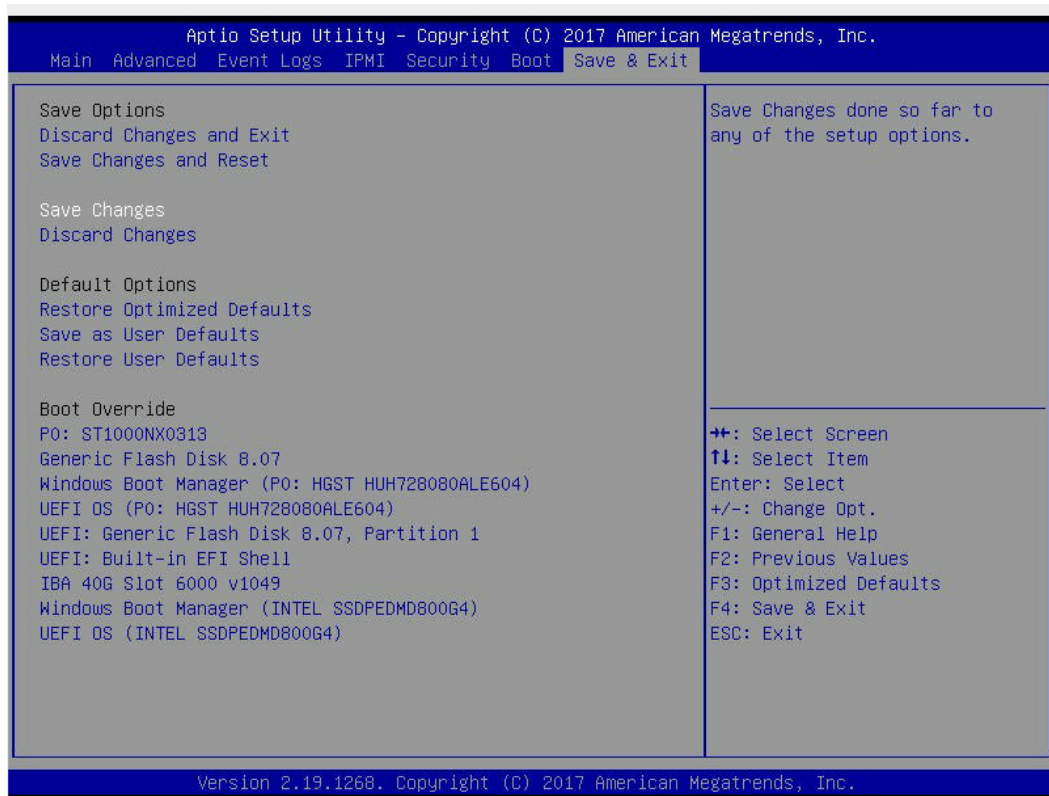

Save Options

Discard Changes and Exit

Select this option to quit the BIOS setup without making any permanent changes to the system configuration and reboot the computer. Select Discard Changes and Exit from the Exit menu and press <Enter>.

Save Changes and Reset

When you have completed the system configuration changes, select this option to leave the BIOS setup utility and reboot the computer for the new system configuration parameters to take effect. Select Save Changes and Exit from the Exit menu and press <Enter>.

Save Changes

When you have completed the system configuration changes, select this option to save all changes made. This will not reset (reboot) the system.

Discard Changes

Select this option and press <Enter> to discard all the changes and return to the AMI BIOS setup utility.

Default Options

Restore Optimized Defaults

To set this feature, select Restore Defaults from the Exit menu and press <Enter> to load manufacturer default settings which are intended for maximum system performance but not for maximum stability.

Save As User Defaults

To set this feature, select Save as User Defaults from the Exit menu and press <Enter>. This enables the user to save any changes to the BIOS setup for future use.

Restore User Defaults

To set this feature, select Restore User Defaults from the Exit menu and press <Enter>. Use this feature to retrieve user-defined settings that were saved previously.

Boot Override

This feature allows the user to override the Boot priorities sequence in the Boot menu, and immediately boot the system with a device specified by the user instead of the one specified in the boot list. This is a one-time override.

Appendix A

BIOS Error Codes

A-1 BIOS Error Beep (POST) Codes

During the POST (Power-On Self-Test) routines, which are performed each time the system is powered on, errors may occur.

Non-fatal errors are those which, in most cases, allow the system to continue the boot-up process. The error messages normally appear on the screen.

Fatal errors are those which will not allow the system to continue the boot-up procedure. If a fatal error occurs, you should consult with your system manufacturer for possible repairs.

These fatal errors are usually communicated through a series of audible beeps. The numbers on the fatal error list (on the following page) correspond to the number of beeps for the corresponding error. All errors listed, with the exception of Beep Code 8, are fatal errors.

BIOS Error Beep (POST) Codes		
Beep Code	Error Message	Description
1 short	Refresh	Circuits have been reset (Ready to power up)
5 short, 1 long	Memory error	No memory detected in system
5 long, 2 short	Display memory read/write error	Video adapter missing or with faulty memory
1 long continuous	System OH	System overheat condition

A-2 Additional BIOS POST Codes

The AMI BIOS supplies additional checkpoint codes, which are documented online at <http://www.supermicro.com/support/manuals/> ("AMI BIOS POST Codes User's Guide").

When BIOS performs the Power On Self Test, it writes checkpoint codes to I/O port 0080h. If the computer cannot complete the boot process, a diagnostic card can be attached to the computer to read I/O port 0080h (Supermicro p/n AOC-LPC80-20).

For information on AMI updates, please refer to <http://www.ami.com/products/>.

Appendix B

Standardized Warning Statements for AC Systems

About Standardized Warning Statements

The following statements are industry standard warnings, provided to warn the user of situations which have the potential for bodily injury. Should you have questions or experience difficulty, contact Supermicro's Technical Support department for assistance. Only certified technicians should attempt to install or configure components.

Read this appendix in its entirety before installing or configuring components in the Supermicro chassis.

These warnings may also be found on our website at http://www.supermicro.com/about/policies/safety_information.cfm.

Warning Definition



Warning! This warning symbol means danger. You are in a situation that could cause bodily injury. Before you work on any equipment, be aware of the hazards involved with electrical circuitry and be familiar with standard practices for preventing accidents.

警告の定義

この警告サインは危険を意味します。

人身事故につながる可能性がありますので、いずれの機器でも動作させる前に、電気回路に含まれる危険性に注意して、標準的な事故防止策に精通して下さい。

此警告符号代表危險。

您正处于可能受到严重伤害的工作环境中。在您使用设备开始工作之前，必须充分意识到触电的危险，并熟练掌握防止事故发生的标准工作程序。请根据每项警告结尾的声明号码找到此设备的安全性警告说明的翻译文本。

此警告符號代表危險。

您正處於可能身體可能會受損傷的工作環境中。在您使用任何設備之前，請注意觸電的危險，並且要熟悉預防事故發生的標準工作程序。請依照每一注意事項後的號碼找到相關的翻譯說明內容。

Warnung

WICHTIGE SICHERHEITSHINWEISE

Dieses Warnsymbol bedeutet Gefahr. Sie befinden sich in einer Situation, die zu Verletzungen führen kann. Machen Sie sich vor der Arbeit mit Geräten mit den Gefahren elektrischer Schaltungen und den üblichen Verfahren zur Vorbeugung vor Unfällen vertraut. Suchen Sie mit der am Ende jeder Warnung angegebenen Anweisungsnummer nach der jeweiligen Übersetzung in den übersetzten Sicherheitshinweisen, die zusammen mit diesem Gerät ausgeliefert wurden.

BEWAHREN SIE DIESE HINWEISE GUT AUF.

INSTRUCCIONES IMPORTANTES DE SEGURIDAD

Este símbolo de aviso indica peligro. Existe riesgo para su integridad física. Antes de manipular cualquier equipo, considere los riesgos de la corriente eléctrica y familiarícese con los procedimientos estándar de prevención de accidentes. Al final de cada advertencia encontrará el número que le ayudará a encontrar el texto traducido en el apartado de traducciones que acompaña a este dispositivo.

GUARDE ESTAS INSTRUCCIONES.

IMPORTANTES INFORMATIONS DE SÉCURITÉ

Ce symbole d'avertissement indique un danger. Vous vous trouvez dans une situation pouvant entraîner des blessures ou des dommages corporels. Avant de travailler sur un équipement, soyez conscient des dangers liés aux circuits électriques et familiarisez-vous avec les procédures couramment utilisées pour éviter les accidents. Pour prendre connaissance des traductions des avertissements figurant dans les consignes de sécurité traduites qui accompagnent cet appareil, référez-vous au numéro de l'instruction situé à la fin de chaque avertissement.

CONSERVEZ CES INFORMATIONS.

תקנון הזהרות אזהרה

הזהרות הבאות הן אזהרות על פי תקני התעשייה, על מנת להזהיר את המשתמש מפני חבלה פיזית אפשרית. במידה ויש שאלות או היתקלות בבעיה כלשהי, יש ליצור קשר עם מחלקת תמיכה טכנית של סופרמיקרו. טכנאים מוסמכים בלבד רשאים להתקין או להגדיר את הרכיבים. יש לקרוא את הנספח במלואו לפני התקנת או הגדרת הרכיבים במארזי סופרמיקרו.

اَكْ ف حالة وُكِي اَي تتسبب ف اصابة جسدهُ هذا الزهز عُ خطر! تحذُرُ .
قبل اَي تعول على اَي هعدات، كي على علن بالوخاطز ال اُجوة عي الذوائر
الكهزبائِة
وكي على دراةُ بالووارسات النقاائِة لو عُ وقع اَي حادث
استخدم رِقن الب اِي الو صُص ف هَاةُ كل تحذُرُ للعشر تزجوتها

안전을 위한 주의사항

경고!

이 경고 기호는 위험이 있음을 알려 줍니다. 작업자의 신체에 부상을 야기 할 수 있는 상태에 있게 됩니다. 모든 장비에 대한 작업을 수행하기 전에 전기회로와 관련된 위험요소들을 확인하시고 사전에 사고를 방지할 수 있도록 표준 작업절차를 준수해 주시기 바랍니다.

해당 번역문을 찾기 위해 각 경고의 마지막 부분에 제공된 경고문 번호를 참조하십시오

BELANGRIJKE VEILIGHEIDSINSTRUCTIES

Dit waarschuwings symbool betekent gevaar. U verkeert in een situatie die lichamelijk letsel kan veroorzaken. Voordat u aan enige apparatuur gaat werken, dient u zich bewust te zijn van de bij een elektrische installatie betrokken risico's en dient u op de hoogte te zijn van de standaard procedures om ongelukken te voorkomen. Gebruik de nummers aan het eind van elke waarschuwing om deze te herleiden naar de desbetreffende locatie.

BEWAAR DEZE INSTRUCTIES

Installation Instructions



Warning! Read the installation instructions before connecting the system to the power source.

設置手順書

システムを電源に接続する前に、設置手順書をお読み下さい。

警告

将此系统连接电源前,请先阅读安装说明。

警告

將系統與電源連接前，請先閱讀安裝說明。

Warnung

Vor dem Anschließen des Systems an die Stromquelle die Installationsanweisungen lesen.

¡Advertencia!

Lea las instrucciones de instalación antes de conectar el sistema a la red de alimentación.

Attention

Avant de brancher le système sur la source d'alimentation, consulter les directives d'installation.

יש לקרוא את הוראות התקנה לפני חיבור המערכת למקור מתח.

اقر إرشادات التركيب قبل توصيل النظام إلى مصدر للطاقة

시스템을 전원에 연결하기 전에 설치 안내를 읽어주십시오.

Waarschuwing

Raadpleeg de installatie-instructies voordat u het systeem op de voedingsbron aansluit.

Circuit Breaker



Warning! This product relies on the building's installation for short-circuit (overcurrent) protection. Ensure that the protective device is rated not greater than: 250 V, 20 A.

サーキット・ブレーカー

この製品は、短絡(過電流)保護装置がある建物での設置を前提としています。

保護装置の定格が250 V、20 Aを超えないことを確認下さい。

警告

此产品的短路(过载电流)保护由建筑物的供电系统提供,确保短路保护设备的额定电流不大于250V,20A。

警告

此產品的短路(過載電流)保護由建築物的供電系統提供,確保短路保護設備的額定電流不大於250V,20A。

Warnung

Dieses Produkt ist darauf angewiesen, dass im Gebäude ein Kurzschluss- bzw. Überstromschutz installiert ist. Stellen Sie sicher, dass der Nennwert der Schutzvorrichtung nicht mehr als: 250 V, 20 A beträgt.

¡Advertencia!

Este equipo utiliza el sistema de protección contra cortocircuitos (o sobrecorrientes) del edificio. Asegúrese de que el dispositivo de protección no sea superior a: 250 V, 20 A.

Attention

Pour ce qui est de la protection contre les courts-circuits (surtension), ce produit dépend de l'installation électrique du local. Vérifiez que le courant nominal du dispositif de protection n'est pas supérieur à :250 V, 20 A.

מוצר זה מסתמך על הגנה המותקנת במבנים למניעת קצר חשמלי. יש לוודא כי המכשיר המגן מפני הקצר החשמלי הוא לא יותר מ-250VDC, 20A

هذا المنتج يعتمد على معدات الحماية من الدوائر القصيرة التي تم تثبيتها في المبنى
تأكد من أن تقييم الجهاز الوقائي ليس أكثر من : 20A, 250V

경고!

이 제품은 전원의 단락(과전류)방지에 대해서 전적으로 건물의 관련 설비에 의존합니다. 보호장치의 정격이 반드시 250V(볼트), 20A(암페어)를 초과하지 않도록 해야 합니다.

Waarschuwing

Dit product is afhankelijk van de kortsluitbeveiliging (overspanning) van uw elektrische installatie. Controleer of het beveiligde apparaat niet groter gedimensioneerd is dan 250V, 20A.

Power Disconnection Warning



Warning! The system must be disconnected from all sources of power and the power cord removed from the power supply module(s) before accessing the chassis interior to install or remove system components.

電源切斷の警告

システムコンポーネントの取り付けまたは取り外しのために、シャーシ内部にアクセスするには、システムの電源はすべてのソースから切斷され、電源コードは電源モジュールから取り外す必要があります。

警告

在你打开机箱并安装或移除内部器件前,必须将系统完全断电,并移除电源线。

警告

在您打開機殼安裝或移除內部元件前，必須將系統完全斷電，並移除電源線。

Warnung

Das System muss von allen Quellen der Energie und vom Netzanschlusskabel getrennt sein, das von den Spg.Versorgungsteilmodulen entfernt wird, bevor es auf den Chassisinnenraum zurückgreift, um Systemsbestandteile anzubringen oder zu entfernen.

¡Advertencia!

El sistema debe ser disconnected de todas las fuentes de energía y del cable eléctrico quitado de los módulos de fuente de alimentación antes de tener acceso el interior del chasis para instalar o para quitar componentes de sistema.

Attention

Le système doit être débranché de toutes les sources de puissance ainsi que de son cordon d'alimentation secteur avant d'accéder à l'intérieur du chasis pour installer ou enlever des composants de système.

אזהרה מפני ניתוק חשמלי

אזהרה!

יש לנתק את המערכת מכל מקורות החשמל ויש להסיר את כבל החשמלי מהספק לפני גישה לחלק הפנימי של המארז לצורך התקנת או הסרת רכיבים.

يجب فصل انظاؤ من جميع مصادر انطاقت وإزانت سهك انكهرباء من وحدة امداد
انطاقت قبم
انصل إلى امناطق انداخهيت نههيكم نتشيج أو إزانت مكناث الجهاز

경고!

시스템에 부품들을 장착하거나 제거하기 위해서는 새시 내부에 접근하기 전에 반드시 전원 공급장치로부터 연결되어있는 모든 전원과 전기코드를 분리해주어야 합니다.

Waarschuwing

Voordat u toegang neemt tot het binnenwerk van de behuizing voor het installeren of verwijderen van systeem onderdelen, dient u alle spanningsbronnen en alle stroomkabels aangesloten op de voeding(en) van de behuizing te verwijderen

Equipment Installation



Warning! Only trained and qualified personnel should be allowed to install, replace, or service this equipment.

機器の設置

トレーニングを受け認定された人だけがこの装置の設置、交換、またはサービスを許可されてい
ます。

警告

只有经过培训且具有资格的人员才能进行此设备的安装、更换和维修。

警告

只有經過受訓且具資格人員才可安裝、更換與維修此設備。

Warnung

Das Installieren, Ersetzen oder Bedienen dieser Ausrüstung sollte nur geschultem, qualifiziertem Personal gestattet werden.

¡Advertencia!

Solamente el personal calificado debe instalar, reemplazar o utilizar este equipo.

Attention

Il est vivement recommandé de confier l'installation, le remplacement et la maintenance de ces équipements à des personnels qualifiés et expérimentés.

אזהרה!

צוות מוסמך בלבד רשאי להתקין, להחליף את הציוד או לתת שירות עבור הציוד.

والمدربيه لتزكيب واستبدال أو خدمة هذا الجهاز يجب أن يسمح فقط للمظفيه المؤهليه

경고!

훈련을 받고 공인된 기술자만이 이 장비의 설치, 교체 또는 서비스를 수행할 수 있습니다.

Waarschuwing

Deze apparatuur mag alleen worden geïnstalleerd, vervangen of hersteld door geschoold en gekwalificeerd personeel.

Restricted Area

Warning! This unit is intended for installation in restricted access areas. A restricted access area can be accessed only through the use of a special tool, lock and key, or other means of security. (This warning does not apply to workstations).

アクセス制限区域

このユニットは、アクセス制限区域に設置されることを想定しています。

アクセス制限区域は、特別なツール、鍵と錠前、その他のセキュリティの手段を用いてのみ出入りが可能です。

警告

此部件应安装在限制进出的场所，限制进出的场所指只能通过使用特殊工具、锁和钥匙或其它安全手段进出的场所。

警告

此装置僅限安裝於進出管制區域，進出管制區域係指僅能以特殊工具、鎖頭及鑰匙或其他安全方式才能進入的區域。

Warnung

Diese Einheit ist zur Installation in Bereichen mit beschränktem Zutritt vorgesehen. Der Zutritt zu derartigen Bereichen ist nur mit einem Spezialwerkzeug, Schloss und Schlüssel oder einer sonstigen Sicherheitsvorkehrung möglich.

¡Advertencia!

Esta unidad ha sido diseñada para instalación en áreas de acceso restringido. Sólo puede obtenerse acceso a una de estas áreas mediante la utilización de una herramienta especial, cerradura con llave u otro medio de seguridad.

Attention

Cet appareil doit être installée dans des zones d'accès réservés. L'accès à une zone d'accès réservé n'est possible qu'en utilisant un outil spécial, un mécanisme de verrouillage et une clé, ou tout autre moyen de sécurité.

אזור עם גישה מוגבלת

אזהרה!

יש להתקין את היחידה באזורים שיש בהם הגבלת גישה. הגישה ניתנת בעזרת 'כלי אבטחה בלבד' (מפתח, מנעול וכד.).

تخصيص هذه انحدة نترك بها ف مناطق محظورة تم .
ممكن اننصل إن منطقت محظورة فقط من خلال استخذاو أداة خاصت
أو أ وس هت أكري نلالأمما ققم ومفتاح

경고!

이 장치는 접근이 제한된 구역에 설치하도록 되어있습니다. 특수도구, 잠금 장치 및 키, 또는 기타 보안 수단을 통해서만 접근 제한 구역에 들어갈 수 있습니다.

Waarschuwing

Dit apparaat is bedoeld voor installatie in gebieden met een beperkte toegang. Toegang tot dergelijke gebieden kunnen alleen verkregen worden door gebruik te maken van speciaal gereedschap, slot en sleutel of andere veiligheidsmaatregelen.

Battery Handling



Warning! There is the danger of explosion if the battery is replaced incorrectly. Replace the battery only with the same or equivalent type recommended by the manufacturer. Dispose of used batteries according to the manufacturer's instructions

電池の取り扱い

電池交換が正しく行われなかった場合、破裂の危険性があります。交換する電池はメーカーが推奨する型、または同等のものを使用下さい。使用済電池は製造元の指示に従って処分して下さい。

警告

電池更換不當會有爆炸危險。請只使用同類電池或制造商推薦的功能相當的電池更換原有電池。請按製造商的說明處理廢舊電池。

警告

電池更換不當會有爆炸危險。請使用製造商建議之相同或功能相當的電池更換原有電池。請按照製造商的說明指示處理廢棄舊電池。

Warnung

Bei Einsetzen einer falschen Batterie besteht Explosionsgefahr. Ersetzen Sie die Batterie nur durch den gleichen oder vom Hersteller empfohlenen Batterietyp. Entsorgen Sie die benutzten Batterien nach den Anweisungen des Herstellers.

Attention

Danger d'explosion si la pile n'est pas remplacée correctement. Ne la remplacer que par une pile de type semblable ou équivalent, recommandée par le fabricant. Jeter les piles usagées conformément aux instructions du fabricant.

¡Advertencia!

Existe peligro de explosión si la batería se reemplaza de manera incorrecta. Reemplazar la batería exclusivamente con el mismo tipo o el equivalente recomendado por el fabricante. Desechar las baterías gastadas según las instrucciones del fabricante.

אזהרה!

קיימת סכנת פיצוץ של הסוללה במידה והוחלפה בדרך לא תקינה. יש להחליף את הסוללה בסוג התואם מחברת יצרן מומלצת. סילוק הסוללות המשומשות יש לבצע לפי הוראות היצרן.

هناك خطر من انفجار في حالة اسحبذال البطارية بطريقة غير صحيحة فعليل
اسحبذال البطارية
فقط بنفس النوع أو ما يعادلها مما أوصت به الشركة المصنعة
جخلص من البطاريات المسحعملة وفقا لعمليات الشركة الصانعة

경고!

배터리가 올바르게 교체되지 않으면 폭발의 위험이 있습니다. 기존 배터리와 동일하거나 제조사에서 권장하는 동등한 종류의 배터리로만 교체해야 합니다. 제조사의 안내에 따라 사용된 배터리를 처리하여 주십시오.

Waarschuwing

Er is ontplofingsgevaar indien de batterij verkeerd vervangen wordt. Vervang de batterij slechts met hetzelfde of een equivalent type die door de fabrikant aanbevolen wordt. Gebruikte batterijen dienen overeenkomstig fabrieksvoorschriften afgevoerd te worden.

Redundant Power Supplies



Warning! This unit might have more than one power supply connection. All connections must be removed to de-energize the unit.

冗長電源装置

このユニットは複数の電源装置が接続されている場合があります。

ユニットの電源を切るためには、すべての接続を取り外さなければなりません。

警告

此部件连接的电源可能不止一个，必须将所有电源断开才能停止给该部件供电。

警告

此装置连接的电源可能不只一个，必须切断所有电源才能停止对该装置的供电。

Warnung

Dieses Gerät kann mehr als eine Stromzufuhr haben. Um sicherzustellen, dass der Einheit kein Strom zugeführt wird, müssen alle Verbindungen entfernt werden.

¡Advertencia!

Puede que esta unidad tenga más de una conexión para fuentes de alimentación. Para cortar por completo el suministro de energía, deben desconectarse todas las conexiones.

Attention

Cette unité peut avoir plus d'une connexion d'alimentation. Pour supprimer toute tension et tout courant électrique de l'unité, toutes les connexions d'alimentation doivent être débranchées.

אם קיים יותר מספק אחד

אזהרה!

ליחידה יש יותר מחיבור אחד של ספק. יש להסיר את כל החיבורים על מנת לרוקן את היחידה.

قد يكون لهذا الجهاز عدة اتصالات بوحدات امداد الطاقة .

يجب إزالة كافة الاتصالات لعسل الوحدة عن الكهرباء

경고!

이 장치에는 한 개 이상의 전원 공급 단자가 연결되어 있을 수 있습니다. 이 장치에 전원을 차단하기 위해서는 모든 연결 단자를 제거해야만 합니다.

Waarschuwing

Deze eenheid kan meer dan één stroomtoevoeraansluiting bevatten. Alle aansluitingen dienen verwijderd te worden om het apparaat stroomloos te maken.

Backplane Voltage



Warning! Hazardous voltage or energy is present on the backplane when the system is operating. Use caution when servicing.

バックプレーンの電圧

システムの稼働中は危険な電圧または電力が、バックプレーン上にかかっています。

修理する際には注意ください。

警告

当システム正在进行时，背板上有很危险的电压或能量，进行维修时务必小心。

警告

當系統正在進行時，背板上危險的電壓或能量，進行維修時務必小心。

Warnung

Wenn das System in Betrieb ist, treten auf der Rückwandplatine gefährliche Spannungen oder Energien auf. Vorsicht bei der Wartung.

¡Advertencia!

Cuando el sistema está en funcionamiento, el voltaje del plano trasero es peligroso. Tenga cuidado cuando lo revise.

Attention

Lorsque le système est en fonctionnement, des tensions électriques circulent sur le fond de panier. Prendre des précautions lors de la maintenance.

מתח בפנל האחורי

אזהרה!

קיימת סכנת מתח בפנל האחורי בזמן תפעול המערכת. יש להיזהר במהלך העבודה.

هناك خطر من التيار الكهربائي أو الطاقة المتجددة على اللوحة
عندما يكون النظام يعمل كه حذرا عند خدمة هذا الجهاز

경고!

시스템이 동작 중일 때 후면판 (Backplane)에는 위험한 전압이나 에너지가 발생 합니다.
서비스 작업 시 주의하십시오.

Waarschuwing

Een gevaarlijke spanning of energie is aanwezig op de backplane wanneer het systeem in gebruik is. Voorzichtigheid is geboden tijdens het onderhoud.

Comply with Local and National Electrical Codes



Warning! Installation of the equipment must comply with local and national electrical codes.

地方および国の電気規格に準拠

機器の取り付けはその地方および国の電気規格に準拠する必要があります。

警告

设备安装必须符合本地与本国电气法规。

警告

設備安裝必須符合本地與本國電氣法規。

Warnung

Die Installation der Geräte muss den Sicherheitsstandards entsprechen.

¡Advertencia!

La instalación del equipo debe cumplir con las normas de electricidad locales y nacionales.

Attention

L'équipement doit être installé conformément aux normes électriques nationales et locales.

תיאום חוקי החשמל הארצי

אזהרה!

התקנת הציוד חייבת להיות תואמת לחוקי החשמל המקומיים והארציים.

تركيب المعدات الكهربائية يجب أن يمتثل للقوايه المحلية والبطية المتعلقة

بالكهرباء

경고!

현 지역 및 국가의 전기 규정에 따라 장비를 설치해야 합니다.

Waarschuwing

Bij installatie van de apparatuur moet worden voldaan aan de lokale en nationale elektriciteitsvoorschriften.

Product Disposal



Warning! Ultimate disposal of this product should be handled according to all national laws and regulations.

製品の廃棄

この製品を廃棄処分する場合、国の関係する全ての法律・条例に従い処理する必要があります。

警告

本产品的废弃处理应根据所有国家的法律和规章进行。

警告

本產品的廢棄處理應根據所有國家的法律和規章進行。

Warnung

Die Entsorgung dieses Produkts sollte gemäß allen Bestimmungen und Gesetzen des Landes erfolgen.

¡Advertencia!

Al deshacerse por completo de este producto debe seguir todas las leyes y reglamentos nacionales.

Attention

La mise au rebut ou le recyclage de ce produit sont généralement soumis à des lois et/ou directives de respect de l'environnement. Renseignez-vous auprès de l'organisme compétent.

סילוק המוצר

אזהרה!

סילוק סופי של מוצר זה חייב להיות בהתאם להנחיות וחוקי המדינה.

التخلص النهائي من هذا المنتج ينبغي التعامل معه وفقا لجميع القوانين واللوائح الوطنية عند

경고!

이 제품은 해당 국가의 관련 법규 및 규정에 따라 폐기되어야 합니다.

Waarschuwing

De uiteindelijke verwijdering van dit product dient te geschieden in overeenstemming met alle nationale wetten en reglementen.

Hot Swap Fan Warning



Warning! Hazardous moving parts. Keep away from moving fan blades. The fans might still be turning when you remove the fan assembly from the chassis. Keep fingers, screwdrivers, and other objects away from the openings in the fan assembly's housing.

ファン・ホットスワップの警告

警告!回転部品に注意。運転中は回転部(羽根)に触れないでください。シャーシから冷却ファン装置を取り外した際、ファンがまだ回転している可能性があります。ファンの開口部に、指、ドライバー、およびその他のものを近づけないで下さい。

警告!

警告! 危險的可移動性零件。請務必與轉動的風扇葉片保持距離。當您從機架移除風扇裝置，風扇可能仍在轉動。小心不要將手指、螺絲起子和其他物品太靠近風扇

警告

危險的可移動性零件。請務必與轉動的風扇葉片保持距離。當您從機架移除風扇裝置，風扇可能仍在轉動。小心不要將手指、螺絲起子和其他物品太靠近風扇。

Warnung

Gefährlich Bewegende Teile. Von den bewegenden Lüfterblätter fern halten. Die Lüfter drehen sich u. U. noch, wenn die Lüfterbaugruppe aus dem Chassis genommen wird. Halten Sie Finger, Schraubendreher und andere Gegenstände von den Öffnungen des Lüftergehäuses entfernt.

¡Advertencia!

Riesgo de piezas móviles. Mantener alejado de las aspas del ventilador. Los ventiladores podran dar vuelta cuando usted quite el montaje del ventilador del chasis. Mantenga los dedos, los destornilladores y todos los objetos lejos de las aberturas del ventilador

Attention

Pieces mobiles dangereuses. Se tenir a l'écart des lames du ventilateur Il est possible que les ventilateurs soient toujours en rotation lorsque vous retirerez le bloc ventilateur du châssis. Prenez garde à ce que doigts, tournevis et autres objets soient éloignés du logement du bloc ventilateur.

אזהרה!

חלקים נעים מסוכנים. התרחק מלהבי המאוורר בפעולה כאשר מסירים את חלקי המאוורר מהמארז, יתכן והמאווררים עדיין עובדים. יש להרחיק למרחק בטוח את האצבעות וכלי עבודה שונים מהפתחים בתוך המאוורר

تحذير! أجزاء متحركة خطيرة. ابتعد عن شفرات المروحة المتحركة. من الممكن أن المراوح لا تزال تدور عند إزالة كتلة المروحة من الهيكل يجب إبقاء الأصابع ومفكات البراغي وغيرها من الأشياء بعيدا عن الفتحات في كتلة المروحة

경고!

움직이는 위험한 부품. 회전하는 송풍 날개에 접근하지 마세요. 새시로부터 팬 조립품을 제거할 때 팬은 여전히 회전하고 있을 수 있습니다. 팬 조립품 외관의 열려있는 부분들로부터 손가락 및 스크류드라이버, 다른 물체들이 가까이 하지 않도록 배치해 주십시오.

Waarschuwing

Gevaarlijk bewegende onderdelen. Houd voldoende afstand tot de bewegende ventilatorbladen. Het is mogelijk dat de ventilator nog draait tijdens het verwijderen van het ventilatorsamenstel uit het chassis. Houd uw vingers, schroevendraaiers en eventuele andere voorwerpen uit de buurt van de openingen in de ventilatorbehuizing.

Power Cable and AC Adapter



Warning! When installing the product, use the provided or designated connection cables, power cables and AC adaptors. Using any other cables and adaptors could cause a malfunction or a fire. Electrical Appliance and Material Safety Law prohibits the use of UL or CSA -certified cables (that have UL/CSA shown on the cord) for any other electrical devices than products designated by Supermicro only.

電源コードとACアダプター

製品を設置する場合、提供または指定および購入された接続ケーブル、電源コードとACアダプターを、該当する地域の条例や安全基準に適合するコードサイズやプラグと共に使用下さい。他のケーブルやアダプタを使用すると故障や火災の原因になることがあります。

電気用品安全法は、ULまたはCSA認定のケーブル(UL/CSEマークがコードに表記)を Supermicro が指定する製品以外に使用することを禁止しています。

警告

安装此产品时,请使用本身提供的或指定的或采购的连接线,电源线和电源适配器。包含遵照当地法规和安全要求的合规的电源线尺寸和插头。使用其它线材或适配器可能会引起故障或火灾。除了Supermicro所指定的产品,电气用品和材料安全法律规定禁止使用未经UL或CSA认证的线材。(线材上会显示UL/CSA符号)。

警告

安裝此產品時,請使用本身提供的或指定的或採購的連接線,電源線和電源適配器。包含遵照當地法規和安全要求的合規的電源線尺寸和插頭。使用其它線材或適配器可能會引起故障或火災。除了Supermicro所指定的產品,電氣用品和材料安全法律規定禁止使用未經UL或CSA認證的線材。(線材上會顯示UL/CSA符號)。

Warnung

Nutzen Sie beim Installieren des Produkts ausschließlich die von uns zur Verfügung gestellten Verbindungskabeln, Stromkabeln und/oder Adapter, die Ihre örtlichen Sicherheitsstandards einhalten. Der Gebrauch von anderen Kabeln und Adapter können Fehlfunktionen oder Feuer verursachen. Die Richtlinien untersagen das Nutzen von UL oder CAS zertifizierten Kabeln (mit UL/CSA gekennzeichnet), an Geräten oder Produkten die nicht mit Supermicro gekennzeichnet sind.

¡Advertencia!

Cuando instale el producto, utilice la conexión provista o designada o procure cables, Cables de alimentación y adaptadores de CA que cumplan con los códigos locales y los requisitos de seguridad, incluyendo el tamaño adecuado del cable y el enchufe. El uso de otros cables y adaptadores podría causar un mal funcionamiento o un incendio. La Ley de Seguridad de Aparatos Eléctricos y de Materiales prohíbe El uso de cables certificados por UL o CSA (que tienen el certificado UL / CSA en el código) para cualquier otros dispositivos eléctricos que los productos designados únicamente por Supermicro.

Attention

Lors de l'installation du produit, utilisez les cables de connection fournis ou désigné ou achetez des cables, cables de puissance et adaptateurs respectant les normes locales et les conditions de securite y compris les tailles de cables et les prises electriques appropriées. L'utilisation d'autres cables et adaptateurs peut provoquer un dysfonctionnement ou un incendie. Appareils électroménagers et la Loi sur la Sécurité Matériel interdit l'utilisation de câbles certifiés- UL ou CSA (qui ont UL ou CSA indiqué sur le code) pour tous les autres appareils électriques sauf les produits désignés par Supermicro seulement.

AC ימאתמו מיילמשח מילבכ

!הרהזא

ךרוצל ומאתוה וא ושכרנ רשא AC מימאתמו מיקפס, מילבכב שמתשהל שי, רצומה תא מיניקתמ רשאכ לכב שומיש . עקתהו לבכה לש הנוכח הדימ ללוכ, תוימוקמה תוחיטבה תושירדל ומאתוה רשאו, הנקתהה למשחה ירישכמב שומישה יקוחל מאתהב. ילמשח רצק וא הלקתל מורגל לולע, רחא גוסמ מאתמ וא לבכ לש דוק מהילע עיפומ רשאכ) UL ב- או CSA ב- מיכמוסומה מילבכב שמתשהל רוסיא מייק, תוחיטבה יקוחו דבלב Supermicro י"ע מאתוה רשא רצומב קר אלא, רחא ילמשח רצומ לכ רובע (UL/CSA)

תאלבאלא אארשב מץ וא אדדחמלא וא ארפוטמלא תאלויסוולא מאדחטסאב מץ, אגתנמלא בייקרת דנע לכלז יפ אמב אילחמלא אמאלסלא תאבלטתמו נינאווקב מאזתלאלא אמ דדרתמלא ראיטלא תאלוחמו אילברמלא קיירח וא לטע יפ בבסטטי דץ ירשא תאלוחמו תאלבאלא יא מאדחטסא. מילסלא סבאלאו ולסומלא מץ ח CSA וא UL לבק נמ אדמתמלא תאלבאלא מאדחטסא תאדמלאו אילברמלא אזהאלל אמאלסלא נונאק רזחי Supermicro לבק נמ אדדחמלאו אילברמלא תאגתנמלא ריג ירשא תאדמ יא אמ (UL/CSA) אמאלע למחתיטלאו

전원 케이블 및 AC 어댑터

경고! 제품을 설치할 때 현지 코드 및 적절한 굵기의 코드와 플러그를 포함한 안전 요구 사항을 준수하여 제공되거나 지정된 연결 혹은 구매 케이블, 전원 케이블 및 AC 어댑터를 사용하십시오.

다른 케이블이나 어댑터를 사용하면 오작동이나 화재가 발생할 수 있습니다. 전기 용품 안전법은 UL 또는 CSA 인증 케이블 (코드에 UL / CSA가 표시된 케이블)을 Supermicro가 지정한 제품 이외의 전기 장치에 사용하는 것을 금지합니다.

Stroomkabel en AC-Adapter

Waarschuwing! Bij het aansluiten van het Product uitsluitend gebruik maken van de geleverde Kabels of een andere geschikte aan te schaffen Aansluitmethode, deze moet altijd voldoen aan de lokale voorschriften en veiligheidsnormen, inclusief de juiste kabeldikte en stekker. Het gebruik van niet geschikte Kabels en/of Adapters kan een storing of brand veroorzaken. Wetgeving voor Elektrische apparatuur en Materiaalveiligheid verbied het gebruik van UL of CSA -gecertificeerde Kabels (met UL/CSA in de code) voor elke andere toepassing dan de door Supermicro hiervoor beoogde Producten.

Appendix C

System Specifications

Processors

Dual Intel 81xx/61xx/51xx/41xx/31xx series processors in a P0 type socket

Note: Please refer to the motherboard specifications pages on our website for updates to supported processors.

Chipset

7049P-TR Intel C621 PCH

7049P-TRT Intel C622 PCH

BIOS

32 MB AMI BIOS SPI Flash BIOS

Memory

Supports up to 2 TB of Load Reduced DIMM (LRDIMM), 3D LRDIMM, Non-Volatile DIMM (NV-DIMM) DDR4 (288-pin) modules in 16 slots

Type: 2666/2400/2133 MHz ECC DDR4

DIMM sizes: Up to 256 GB

SATA Controller

Eight SATA 3.0 ports supported by Intel PCH (I-SATA 0-3, I-SATA 4-7)

Four S-SATA 3.0 ports supported by Intel SCU

Two SATA 3.0 ports with power-pins built-in, with support for Supermicro SuperDOM (S-SATA4/S-ISATA5)

Storage Drives

Eight 3.5" hot-swap SATA drive bays

PCI Expansion Slots

Two PCI-Express 3.0 x8 slots

Four PCI-Express 3.0 x16 slots

Motherboard

X11DPi-N(T); Extended ATX form factor (12 x 13 in. / 305 x 330 mm.)

Chassis

SC745BAC-R1K28B; Tower/4U Rackmount, 7 x 19 x 27 in. / 178 x 483 x 686 mm. (W x H x D)

System Cooling

Three 8-cm cooling fans and two 8-cm exhaust fans

Power Supply

Dual 1000/1280 W modules, 80Plus Platinum level

Model: PWS-1K28P-SQ

AC Input: 100-240 V, 50-60 Hz

Rated Input Current: 1000 W Output @ 100-140 Vac: 8-12 A; 1280 W Output @ 180-240 Vac: 6-8 A

Rated DC Output Power:

+12 V, for 1000 W - 83 A, for 1280 W - 107 A

+5 V standby - 4 A

Operating Environment

Operating Temperature: 10° to 35° C (50° to 95° F)

Non-operating Temperature: -40° to 60° C (-40° to 140° F)

Operating Relative Humidity: 20% to 95% (non-condensing)

Non-operating Relative Humidity: 5% to 95% (non-condensing)

Regulatory Compliance

Electromagnetic Emissions: FCC Class A, EN 55032 Class A, EN 61000-3-2/3-3, CISPR 22 Class A

Electromagnetic Immunity: EN 55024/CISPR 24, (EN 61000-4-2, EN 61000-4-3, EN 61000-4-4, EN 61000-4-5, EN 61000-4-6, EN 61000-4-8, EN 61000-4-11)

Safety: CSA/EN/IEC/UL 60950-1 Compliant, UL or CSA Listed (USA and Canada), CE Marking (Europe)

Perchlorate Warning

California Best Management Practices Regulations for Perchlorate Materials: This Perchlorate warning applies only to products containing CR (Manganese Dioxide) Lithium coin cells. "Perchlorate Material-special handling may apply. See www.dtsc.ca.gov/hazardouswaste/perchlorate"

Appendix D

UEFI BIOS Recovery

Warning: Do not upgrade the BIOS unless your system has a BIOS-related issue. Flashing the wrong BIOS can cause irreparable damage to the system. In no event shall Supermicro be liable for direct, indirect, special, incidental, or consequential damages arising from a BIOS update. If you need to update the BIOS, do not shut down or reset the system while the BIOS is updating to avoid possible boot failure.

D.1 Overview

The Unified Extensible Firmware Interface (UEFI) provides a software-based interface between the operating system and the platform firmware in the pre-boot environment. The UEFI specification supports an architecture-independent mechanism that will allow the UEFI OS loader stored in an add-on card to boot the system. The UEFI offers clean, hands-off management to a computer during system boot.

D.2 Recovering the UEFI BIOS Image

A UEFI BIOS flash chip consists of a recovery BIOS block and a main BIOS block (a main BIOS image). The recovery block contains critical BIOS codes, including memory detection and recovery codes for the user to flash a healthy BIOS image if the original main BIOS image is corrupted. When the system power is turned on, the recovery block codes execute first. Once this process is complete, the main BIOS code will continue with system initialization and the remaining POST (Power-On Self-Test) routines.

Note 1: Follow the BIOS recovery instructions below for BIOS recovery when the main BIOS block crashes.

Note 2: When the BIOS recovery block crashes, you will need to follow the procedures to make a Returned Merchandise Authorization (RMA) request. (For a RMA request, please see section 3.5 for more information). Also, you may use the Supermicro Update Manager (SUM) Out-of-Band (OOB) (https://www.supermicro.com.tw/products/nfo/SMS_SUM.cfm) to reflash the BIOS.

D.3 Recovering the Main BIOS Block with a USB Device

This feature allows the user to recover the main BIOS image using a USB-attached device without additional utilities used. A USB flash device such as a USB Flash Drive, or a USB

CD/DVD ROM/RW device can be used for this purpose. However, a USB Hard Disk drive cannot be used for BIOS recovery at this time.

The file system supported by the recovery block is FAT (including FAT12, FAT16, and FAT32) which is installed on a bootable or non-bootable USB-attached device. However, the BIOS might need several minutes to locate the SUPER.ROM file if the media size becomes too large due to the huge volumes of folders and files stored in the device.

To perform UEFI BIOS recovery using a USB-attached device, follow the instructions below.

1. Using a different machine, copy the "Super.ROM" binary image file into the Root "\" directory of a USB device or a writable CD/DVD.

Notes: 1. If you cannot locate the "Super.ROM" file in your drive disk, visit our website at www.supermicro.com to download the BIOS package. Extract the BIOS binary image into a USB flash device and rename it "Super.ROM" for the BIOS recovery use. 2. Before recovering the main BIOS image, confirm that the "Super.ROM" binary image file you download is the same version or a close version meant for your motherboard.

2. Insert the USB device that contains the new BIOS image ("Super.ROM") into your USB drive and reset the system when the following screen appears.



3. After locating the healthy BIOS binary image, the system will enter the BIOS Recovery menu as shown below.

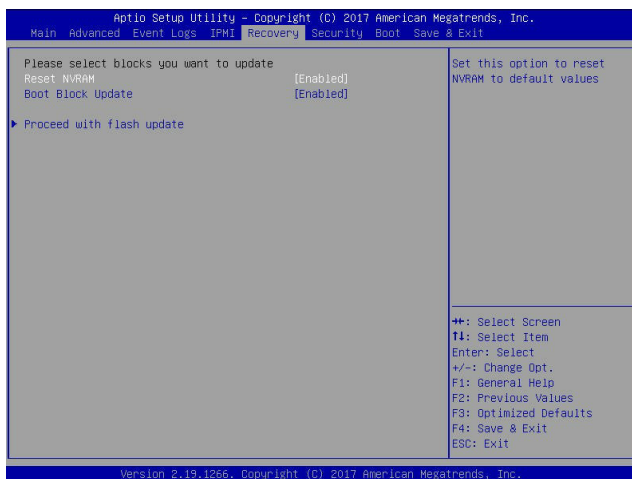

Note: At this point, you may decide if you want to start the BIOS recovery. If you decide to proceed with BIOS recovery, follow the procedures below.

4. When the screen as shown above displays, use the arrow keys to select the item "Proceed with flash update" and press the <Enter> key. You will see the BIOS recovery progress as shown in the screen below.

Note: Do not interrupt the BIOS flashing process until it has completed.

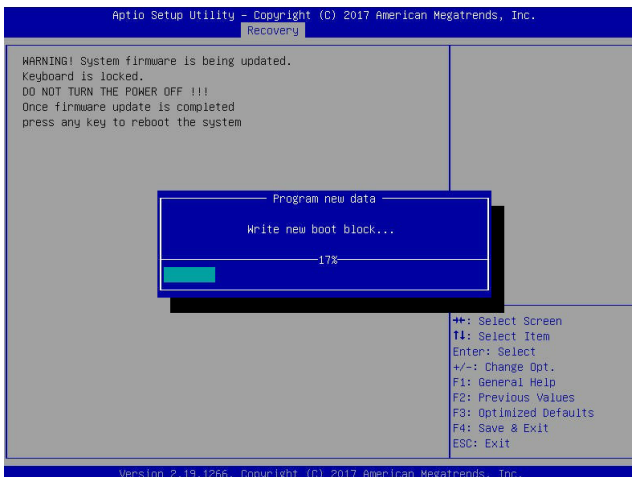

- After the BIOS recovery process is complete, press any key to reboot the system.

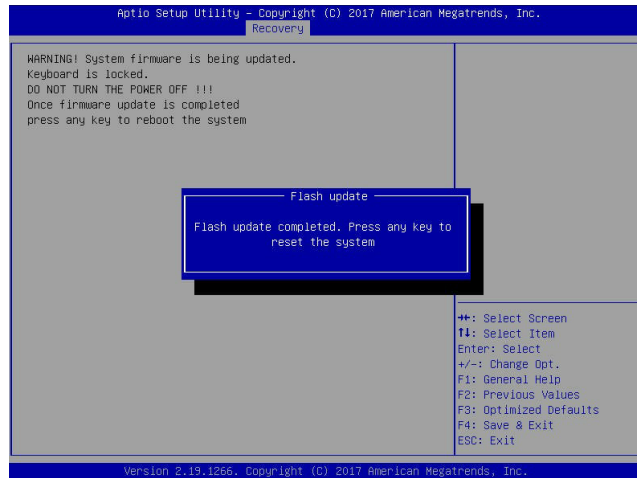

- Using a different system, extract the BIOS package into a USB flash drive.
- Press continuously during system boot to enter the BIOS Setup utility. From the top of the tool bar, select Boot to enter the submenu. From the submenu list, select Boot Option #1 as shown below. Then, set Boot Option #1 to [UEFI AP:UEFI: Built-in EFI Shell]. Press <F4> to save the settings and exit the BIOS Setup utility.

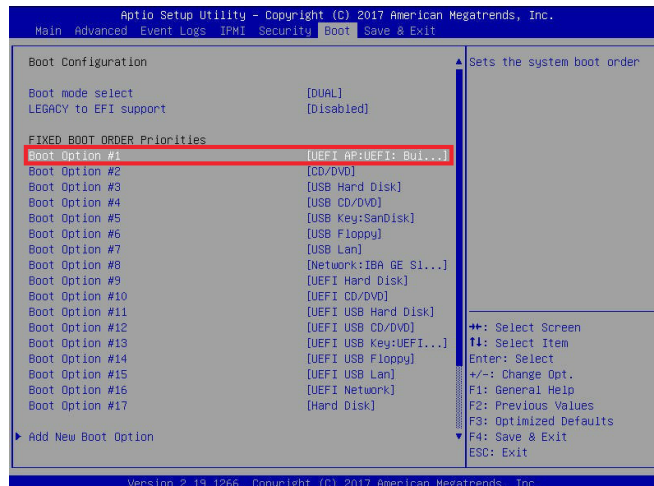

8. When the UEFI Shell prompt appears, type `fs#` to change the device directory path. Go to the directory that contains the BIOS package you extracted earlier from Step 6. Enter `flash.nsh BIOSname.###` at the prompt to start the BIOS update process.

```

UEFI Interactive Shell v2.1
EDK II
UEFI v2.50 (American Megatrends, 0x0005000C)
Mapping Table
FS0: Alias(s):HD0:0B:BLK1:
      PciRoot(0x0)/Pci(0x14,0x0)/USB(0x11,0x0)/HD(1,MBR,0x3791072,0x800,0x1
DR959C)
      BLK0: Alias(s):
      PciRoot(0x0)/Pci(0x14,0x0)/USB(0x11,0x0)
Press F8 in 1 seconds to skip startup.nsh or any other key to continue.
Shell> fs0:
FS0:\> cd \AFUDOS
FS0:\AFUDOS> cd \SNIPME2_03162017
FS0:\AFUDOS\SNIPME2_03162017> flash.nsh X110PU7_314

```

Note: *Do not interrupt this process* until the BIOS flashing is complete.

```

Done.
[ Access Cmos Port Ex ]
<Read>
Index 0x51: 0x10

Done.
*****
* Program BIOS and ME (including FDT) regions...
*****
| AMT Firmware Update Utility v5.09.01.1917
| Copyright (C)2017 American Megatrends Inc. All Rights Reserved.
|-----|
CPUID = 50652

Reading flash ..... done
- ME Data Size checking - ok
- FFS checksums ..... ok
- Check RomLayout ..... Ok
Erasing Boot Block ..... done
Updating Boot Block ..... done
Verifying Boot Block ..... done
Erasing Main Block ..... 0x00132000 (0x)

```

9. The screen above indicates that the BIOS update process is complete. When you see the screen above, unplug the AC power cable from the power supply, clear CMOS, and plug the AC power cable in the power supply again to power on the system.

```

Verifying NDB Block ..... done
- Update success for FDR
- Update success for IE
- Successful Update Recovery Loader to OPRx11
- Successful Update MFSB11
- Successful Update FPR11
- Successful Update MFS, IVBI and IVB211
- Successful Update FLOG and UTDK11
- ME Entire Image update success !!
WARNING : System must power-off to have the changes take effect!
Moving FS0:\AFUDOS\SNIPME2_03162017\Fdtv64.efi -> FS0:\AFUDOS\SNIPME2_03162017\F
dt1.smc
- [ok]
Moving FS0:\AFUDOS\SNIPME2_03162017\Fuef1x64.efi -> FS0:\AFUDOS\SNIPME2_0316201
7\Fuef1.smc
- [ok]
*****
* Please ignore this 'Shell: Cannot read from file - Device Error'
* warning message due to it does not impact flashing process.
*****
Deleting "FS0:\AFUDOS\SNIPME2_03162017\Fuef1.smc"
Delete successful.
FS0:\>

```

10. Press `` continuously to enter the BIOS Setup utility.
11. Press `<F3>` to load the default settings.
12. After loading the default settings, press `<F4>` to save the settings and exit the BIOS Setup utility.