

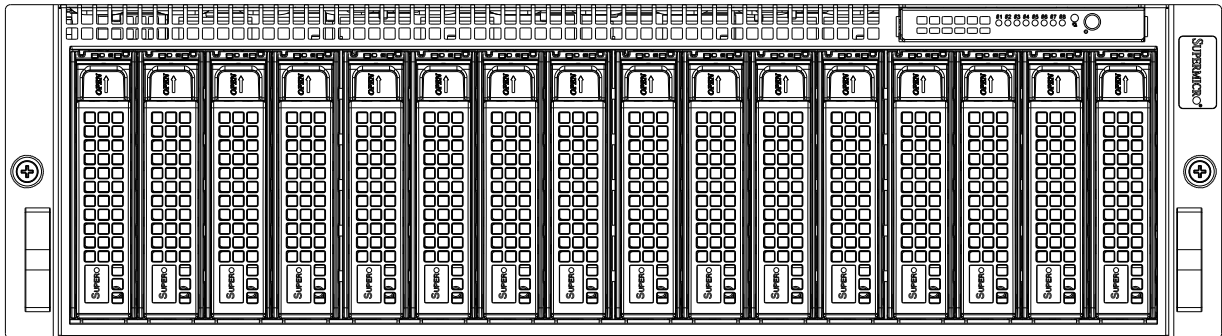

# SUPERSERVER<sup>®</sup> 5039MC-H8TRF



USER'S MANUAL

Revision 1.0

The information in this User's Manual has been carefully reviewed and is believed to be accurate. The vendor assumes no responsibility for any inaccuracies that may be contained in this document, and makes no commitment to update or to keep current the information in this manual, or to notify any person or organization of the updates. Please Note: For the most up-to-date version of this manual, please see our website at [www.supermicro.com](http://www.supermicro.com).

Super Micro Computer, Inc. ("Supermicro") reserves the right to make changes to the product described in this manual at any time and without notice. This product, including software and documentation, is the property of Supermicro and/or its licensors, and is supplied only under a license. Any use or reproduction of this product is not allowed, except as expressly permitted by the terms of said license.

IN NO EVENT WILL Super Micro Computer, Inc. BE LIABLE FOR DIRECT, INDIRECT, SPECIAL, INCIDENTAL, SPECULATIVE OR CONSEQUENTIAL DAMAGES ARISING FROM THE USE OR INABILITY TO USE THIS PRODUCT OR DOCUMENTATION, EVEN IF ADVISED OF THE POSSIBILITY OF SUCH DAMAGES. IN PARTICULAR, SUPER MICRO COMPUTER, INC. SHALL NOT HAVE LIABILITY FOR ANY HARDWARE, SOFTWARE, OR DATA STORED OR USED WITH THE PRODUCT, INCLUDING THE COSTS OF REPAIRING, REPLACING, INTEGRATING, INSTALLING OR RECOVERING SUCH HARDWARE, SOFTWARE, OR DATA.

Any disputes arising between manufacturer and customer shall be governed by the laws of Santa Clara County in the State of California, USA. The State of California, County of Santa Clara shall be the exclusive venue for the resolution of any such disputes. Supermicro's total liability for all claims will not exceed the price paid for the hardware product.

FCC Statement: This equipment has been tested and found to comply with the limits for a Class A digital device pursuant to Part 15 of the FCC Rules. These limits are designed to provide reasonable protection against harmful interference when the equipment is operated in a commercial environment. This equipment generates, uses, and can radiate radio frequency energy and, if not installed and used in accordance with the manufacturer's instruction manual, may cause harmful interference with radio communications. Operation of this equipment in a residential area is likely to cause harmful interference, in which case you will be required to correct the interference at your own expense.

California Best Management Practices Regulations for Perchlorate Materials: This Perchlorate warning applies only to products containing CR (Manganese Dioxide) Lithium coin cells. "Perchlorate Material-special handling may apply. See [www.dtsc.ca.gov/hazardouswaste/perchlorate](http://www.dtsc.ca.gov/hazardouswaste/perchlorate)".



WARNING: This product can expose you to chemicals including lead, known to the State of California to cause cancer and birth defects or other reproductive harm. For more information, go to [www.P65Warnings.ca.gov](http://www.P65Warnings.ca.gov).

The products sold by Supermicro are not intended for and will not be used in life support systems, medical equipment, nuclear facilities or systems, aircraft, aircraft devices, aircraft/emergency communication devices or other critical systems whose failure to perform be reasonably expected to result in significant injury or loss of life or catastrophic property damage. Accordingly, Supermicro disclaims any and all liability, and should buyer use or sell such products for use in such ultra-hazardous applications, it does so entirely at its own risk. Furthermore, buyer agrees to fully indemnify, defend and hold Supermicro harmless for and against any and all claims, demands, actions, litigation, and proceedings of any kind arising out of or related to such ultra-hazardous use or sale.

Manual Revision 1.0

Release Date: April 24, 2019

Unless you request and receive written permission from Super Micro Computer, Inc., you may not copy any part of this document. Information in this document is subject to change without notice. Other products and companies referred to herein are trademarks or registered trademarks of their respective companies or mark holders.

Copyright © 2019 by Super Micro Computer, Inc.

All rights reserved.

**Printed in the United States of America**

# Preface

## About this Manual

This manual is written for professional system integrators and PC technicians. It provides information for the installation and use of the server. Installation and maintenance should be performed by experienced technicians only.

Please refer to the 5039MC-H8TRF server specifications page on our website for updates on supported memory, processors and operating systems (<http://www.supermicro.com>).

## Notes

For your system to work properly, please follow the links below to download all necessary drivers/utilities and the user's manual for your server.

- Supermicro product manuals: <http://www.supermicro.com/support/manuals/>
- Product drivers and utilities: <https://www.supermicro.com/wftp>
- Product safety info: [http://www.supermicro.com/about/policies/safety\\_information.cfm](http://www.supermicro.com/about/policies/safety_information.cfm)

If you have any questions, please contact our support team at:  
[support@supermicro.com](mailto:support@supermicro.com)

This manual may be periodically updated without notice. Please check the Supermicro website for possible updates to the manual revision level.

## Warnings

Special attention should be given to the following symbols used in this manual.



**Warning!** Indicates important information given to prevent equipment/property damage or personal injury.



**Warning!** Indicates high voltage may be encountered when performing a procedure.

# Contents

## **Chapter 1 Introduction**

1.1 Overview.....	8
1.2 Unpacking the System .....	8
1.3 System Features .....	9
1.4 Chassis Features .....	10
Control Panel .....	10
Chassis Front.....	11
Chassis Rear.....	12
Connecting to a Node.....	13
1.5 Motherboard Layout .....	14
Quick Reference Table.....	15
System Block Diagram.....	16
1.6 Where to Get Replacement Components.....	17
1.7 Returning Merchandise for Service.....	17

## **Chapter 2 Server Installation**

2.1 Overview.....	18
2.2 Preparing for Setup.....	18
Choosing a Setup Location.....	18
Rack Precautions .....	18
Server Precautions.....	19
Rack Mounting Considerations .....	19
Ambient Operating Temperature.....	19
Airflow .....	19
Mechanical Loading.....	19
Circuit Overloading .....	20
Reliable Ground.....	20
2.3 Installing the Rails .....	21
Identifying the Rails.....	21
Releasing the Inner Rail .....	22
Installing the Inner Rails on the Chassis .....	23
Installing the Outer Rails onto the Rack.....	24
2.4 Installing the Chassis into a Rack.....	25
Removing the Chassis from the Rack .....	26

---

---

**Chapter 3 Maintenance and Component Installation**

3.1	Removing Power .....	27
3.2	Accessing the System .....	28
	Removing a Computing Node .....	28
	Removing the Chassis Cover .....	29
3.3	Motherboard Components .....	30
	Memory Installation .....	30
	Memory Support .....	30
	DIMM Module Population Configuration .....	30
	DIMM Module Population Sequence .....	31
	Install Procedure .....	32
	Expansion Module .....	33
	Motherboard Battery .....	34
3.4	Chassis Components .....	35
	Corresponding Nodes, Fans and Hard Drives .....	35
	Storage Drives .....	36
	Drive Carrier Indicators .....	36
	Checking the Temperature of an NVMe M.2 Drive .....	39
	M.2 Solid State Drives .....	39
	System Cooling .....	40
	Fans .....	40
	Air Shroud .....	41
	Power Supply .....	42
	PCI Expansion Cards .....	43

**Chapter 4 Motherboard Connections**

4.1	Power Connections .....	45
4.2	Headers and Connectors .....	45
4.3	Rear Input/Output Ports .....	47
	Rear I/O Ports .....	47
4.4	Jumpers .....	49
	Explanation of Jumpers .....	49
4.5	LED Indicators .....	51

**Chapter 5 Software**

5.1 Microsoft Windows OS Installation.....52  
5.2 Driver Installation.....54  
5.3 SuperDoctor® 5.....55  
5.4 IPMI .....56

**Chapter 6 UEFI BIOS**

6.1 Introduction.....57  
    Starting BIOS Setup Utility.....57  
6.2 Main Setup .....57  
6.3 Advanced Setup Configurations.....59  
6.4 IPMI ..... 83  
6.5 Security.....86  
6.6 Event Logs .....91  
6.7 Boot .....93  
6.8 Save & Exit.....95

**Appendix A BIOS Error Codes**

**Appendix B Standardized Warning Statements for AC Systems**

**Appendix C System Specifications**

**Appendix D UEFI BIOS Recovery**

**Appendix E IPMI Crash Dump**

## Contacting Supermicro

### Headquarters

Address: Super Micro Computer, Inc.  
980 Rock Ave.  
San Jose, CA 95131 U.S.A.

Tel: +1 (408) 503-8000

Fax: +1 (408) 503-8008

Email: [marketing@supermicro.com](mailto:marketing@supermicro.com) (General Information)  
[support@supermicro.com](mailto:support@supermicro.com) (Technical Support)

Website: [www.supermicro.com](http://www.supermicro.com)

### Europe

Address: Super Micro Computer B.V.  
Het Sterrenbeeld 28, 5215 ML  
's-Hertogenbosch, The Netherlands

Tel: +31 (0) 73-6400390

Fax: +31 (0) 73-6416525

Email: [sales@supermicro.nl](mailto:sales@supermicro.nl) (General Information)  
[support@supermicro.nl](mailto:support@supermicro.nl) (Technical Support)  
[rma@supermicro.nl](mailto:rma@supermicro.nl) (Customer Support)

Website: [www.supermicro.nl](http://www.supermicro.nl)

### Asia-Pacific

Address: Super Micro Computer, Inc.  
3F, No. 150, Jian 1st Rd.  
Zhonghe Dist., New Taipei City 235  
Taiwan (R.O.C)

Tel: +886-(2) 8226-3990

Fax: +886-(2) 8226-3992

Email: [support@supermicro.com.tw](mailto:support@supermicro.com.tw)

Website: [www.supermicro.com.tw](http://www.supermicro.com.tw)

# Chapter 1

## Introduction

### 1.1 Overview

This chapter provides a brief outline of the functions and features of the 5039MC-H8TRF server. It is a 3U MicroCloud system with eight computing nodes, each with an X11SCD-F motherboard, all enclosed in the SC938NH-R2K04BP chassis.

In addition to the motherboards and chassis, several important parts that are included with the system are listed below.

Main Parts List		
Description	Part Number	Quantity
Power supply module	PWS-2K04A-1R	2
Storage drive backplane	AOM-BPN-938NH-P	1
Power distributors	AOM-PDB-PT938-LSG AOM-PDB-PT938-RSG	1 each
Network cards	AOC-CGP-I2-P	8
IPMI Dedicated LAN	AOM-LAN-MC8-P	1
Fans	FAN-0194L4	4
Air shrouds	MCP-310-93805-0B	16
Riser cards	RSC-RR1U-E16	8
Rack mount rails	MCP-290-00057-0N	1 set

### 1.2 Unpacking the System

Inspect the box the system was shipped in and note if it was damaged in any way. If any equipment appears damaged, please file a damage claim with the carrier who delivered it.

Decide on a suitable location for the rack unit that will hold the server. It should be situated in a clean, dust-free area that is well ventilated. Avoid areas where heat, electrical noise, and electromagnetic fields are generated. It will also require a grounded AC power outlet nearby. Be sure to read the precautions and considerations noted in Appendix B.

## 1.3 System Features

The following table is an overview of the main features of the 5039MC-H8TRF server.

<b>System Features</b>
<b>Motherboard (per node)</b>
X11SCD-F
<b>Chassis</b>
SC938NH-R2K04BP
<b>CPU (per node)</b>
Single socket H4 (LGA 1151) supports Intel Xeon E-2100 series processor, 8th Gen. Core, i3 Pentium / Celeron, 16 threads, 95W, Intel C246 chip <b>Note:</b> CPU overheat system event log may show up under special circumstances when the CPUs are under Turbo mode or under stress. The thermal throttle is normal when Intel Turbo Boost Technology is active.
<b>Memory (per node)</b>
Up to 128GB unbuffered ECC in four DIMM slots with speed of up to DDR4-2666MHz
<b>Expansion Slots (per node)</b>
One PCI-E 3.0 x8 LP open end slot and one MicroLP slot (MicroLP upgradeable)
<b>Storage Drives</b>
Two 3.5" SATA3 drives or 2x 2.5" SATA3 with optional kits Up to two M.2 PCI-E 3.0 x4 slots with SATA3 support (M-Key 2280/22110)
<b>Power</b>
2000W redundant 80Plus Titanium level module
<b>Cooling</b>
Four 8-cm heavy duty fans, CPU heatsinks, air shrouds to direct air flow
<b>Input/Output (per node)</b>
LAN: Two Gb Ethernet ports via Micro-LP network card With KVM dongle: Two USB 2.0 ports, one VGA port, one COM port (per system) 1+1 dedicated IPMI LAN port for 8 nodes management
<b>Form Factor</b>
3U rackmount; (WxHxD) 17.26 x 5.21 x 23.2 in. (438 x 132 x 589 mm)

## 1.4 Chassis Features

### Control Panel

Power switches and status LEDs are located on the control panel on the front of the chassis.

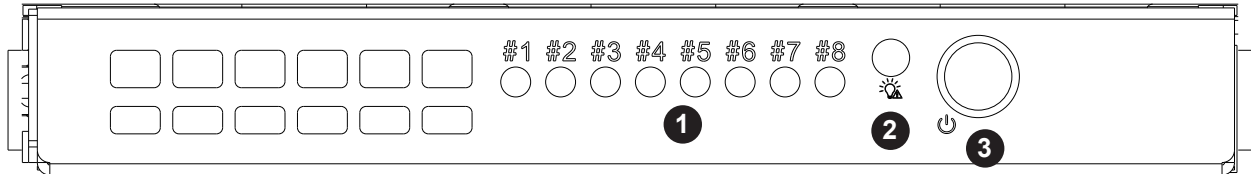

Figure 1-1. Control Panel

Control Panel Features		
Item	Features	Description
1	Node activity	Indicates activity on the numbered node
2	Power Fail	Indicates a failed power supply module
3	Power button	The main power switch applies or removes primary power from the power supply to the chassis but maintains standby power.

Node Activity LED Indicators	
LED Appearance	Description
Solid Green	The node is powered on and operating normally
Blinking Green	The node is in the process of shutting down
Solid Red	The node is detecting an overheated condition
1Hz Blinking Red	The node is detecting a fan failure
.25Hz Blinking Red	The node is detecting a power failure
Solid Blue	The node local UID is on
1Hz Blinking Blue	The node remote UID is on
No Illumination	The node is powered down

## Chassis Front

The illustration below shows the features included on the front of the chassis.

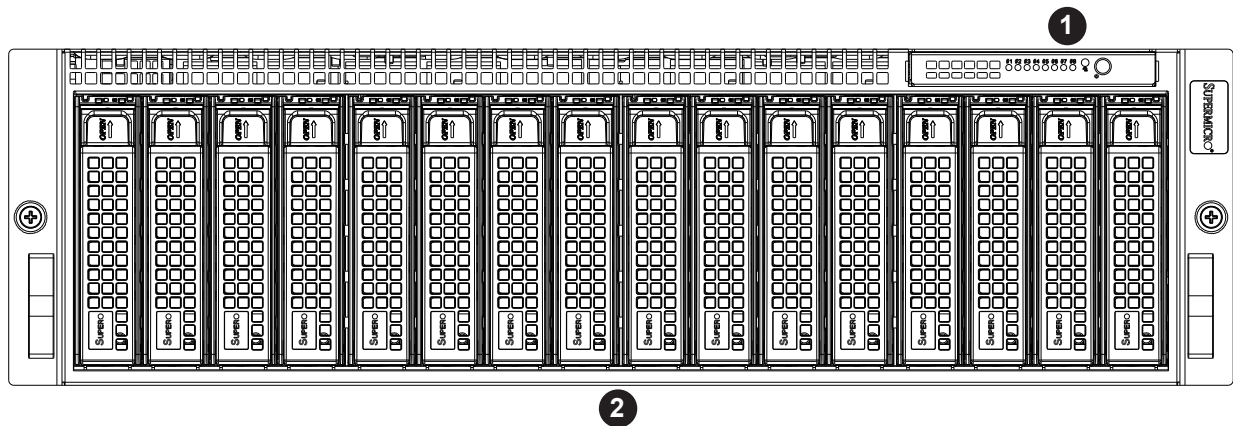

Figure 1-2. Front View

Chassis Front Features		
Item	Features	Description
1	Control Panel	Power buttons and status indicators; details on the previous page
2	Storage Drives	Sixteen 3.5" drive bays, two for each computing node; drive carriers display status lights

## Chassis Rear

The illustration below shows the features included on the rear of the chassis. Computing nodes and power supply modules display status lights.

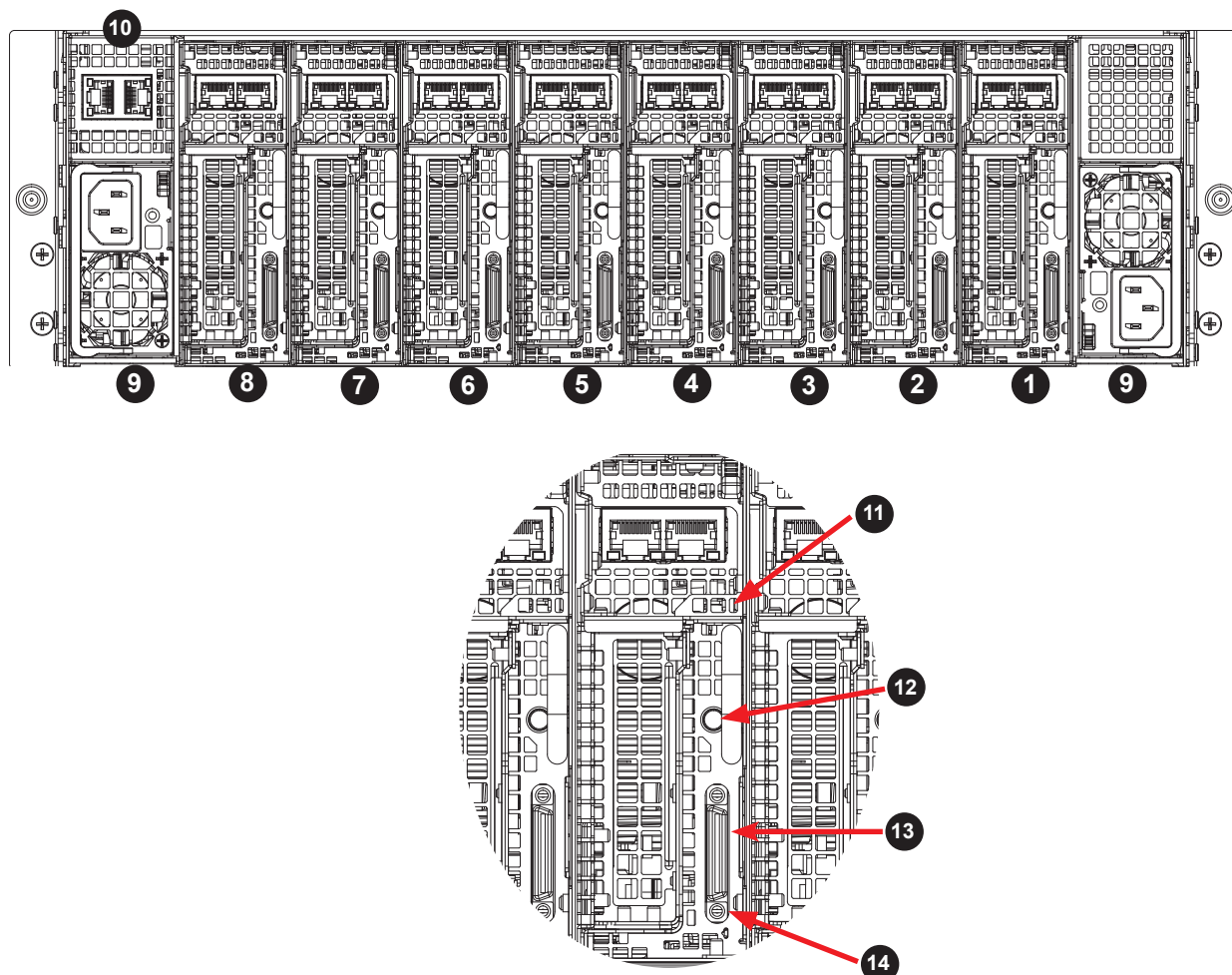

Figure 1-3. Rear View

Chassis Rear Features		
Item	Features	Description
1 – 8	Nodes	Each node features a power button, two LAN ports, one dedicated IPMI LAN port, and a VGA port
9	Power Supplies	Two redundant power supply modules, PWS1 on the left, PWS2 on the right
10	IPMI LAN ports	Two ports that can be used in two ways: <i>Cascade</i> (connect the first port to a management device and the second port to another server) or <i>Redundancy</i> (connect each port to a different subnetwork switch).
11	UID Button	Toggle switch and LED indicator for Unit ID (blue)
12	Power Button	Node power switch and indicator (green)
13	KVM Port	One VGA, one COM, and two USB 2.0 (with KVM dongle)
14	Fail LED	Indicator for node or corresponding storage drive failure (red); Overheat (OH); PWR Fail (.25HZ); Fan Fail LED (1HZ)



Figure 1-4. Node I/O Features

Node I/O Features	
Item	Description
1	JKVM1
2	SW2
3	JUIDB1

### ***Connecting to a Node***

USB, COM, and VGA port capabilities can be added to any node through the KVM port on the rear. Plug in the adapter (dongle) to use these ports.



Figure 1-5. Adapter to Provide USB, COM, and VGA Ports

## 1.5 Motherboard Layout

Below is a layout of the X11SCD-F motherboard with jumper, connector, and LED locations shown. See the table on the following page for descriptions. For detailed descriptions, pinout information, and jumper settings, refer to Chapter 4.

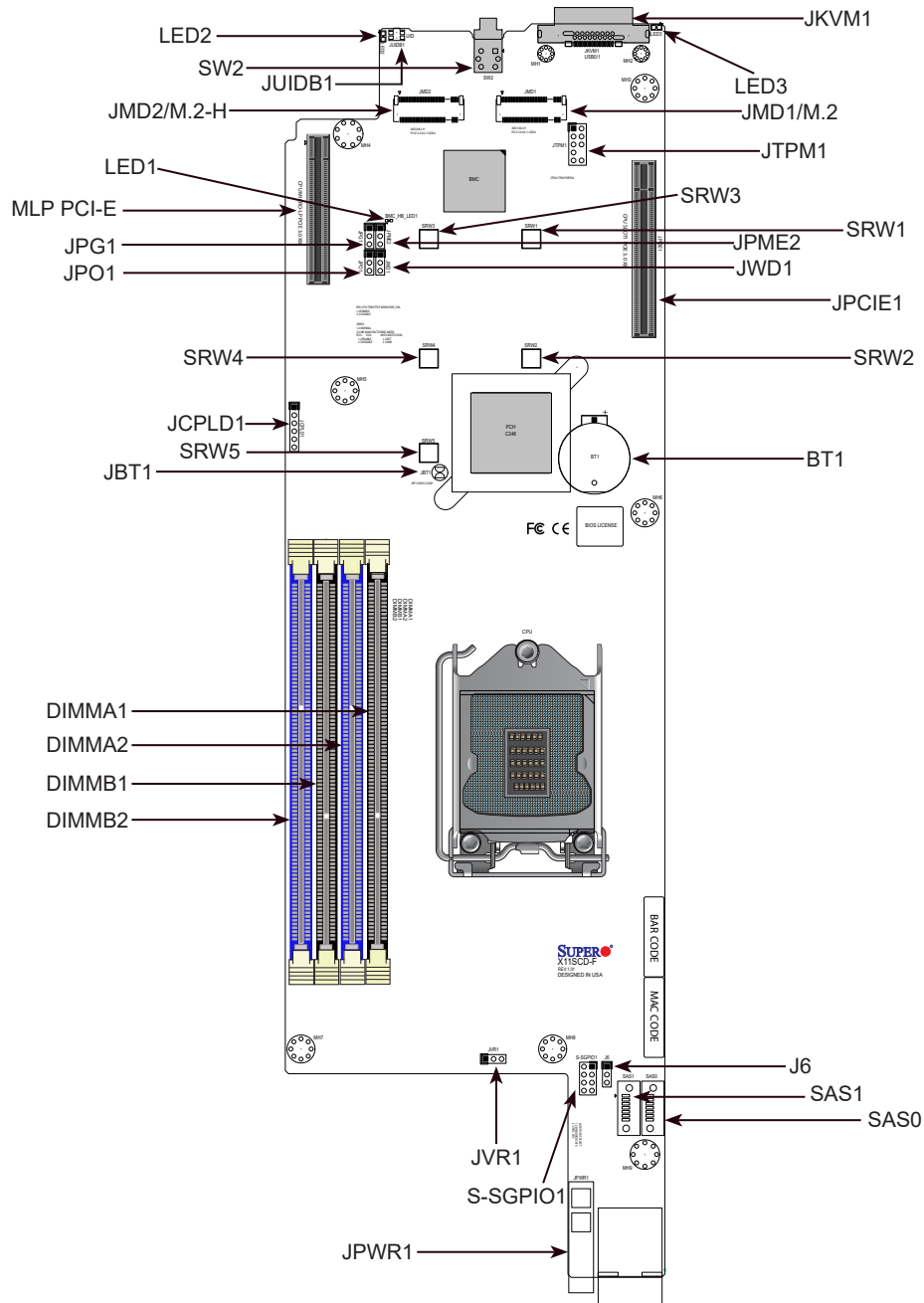

Figure 1-6. Motherboard Layout

## Quick Reference Table

Jumper	Description	Default Setting
JBT1	CMOS Clear	Open (Normal) Closed: Clear CMOS
JPG1	Onboard VGA Enable/Disable	Pins 1-2 (Enabled)
JPME2	Manufacturing Mode	Pins 1-2 (Normal)
JWD1	Watch Dog Timer	Pins 1-2 (Reset)
JPO1	CPU throttle when PWR_FAIL	Pins 1-2 (Enabled) Pins 2-3 Disable (Default)
J6	SATA/SAS select	Pins 1-2 Onboard SATA (Default) Pins 2-3 AOC SAS

Connector	Description
BT1	Onboard CMOS battery socket
SAS0/SAS1	SAS AOC input
JCPLD1	CPLD code programming
JKVM1	VGA/COM1/USB Connector on the I/O backplane
JMD1-JMD2	M.2 Slot
JTPM1	Trusted Platform Module/Port 80 Connector
JPCIE1	CPU PCIE 3.0 x8 Slot
JPWR1	12V in ATX Power Connector
JVR1	VRM I <sup>2</sup> C SMBus to Header
JUIDB1	Unit Identifier Switch
MLP PCI-E 3.0 x8	Micro Low Profile PCI-E 3.0 x8 Slot
S-SGPIO1	Serial General Purpose I/O Header for SAS AOC input
SRW1-5	M.2 stand off
S-SGPIO1	Serial Link General Purpose I/O Header
SW2	Power switch

LED	Description	Status
LED1	BMC Heartbeat LED	Green Blinking: BMC Normal
LED2	UID LED	Solid Blue: Unit Identified
LED3	OH/Power, Fail/FAN Fail LED	Blinking Red: Power Fail or FAN Fail Solid Red: Over Heat

w

## System Block Diagram

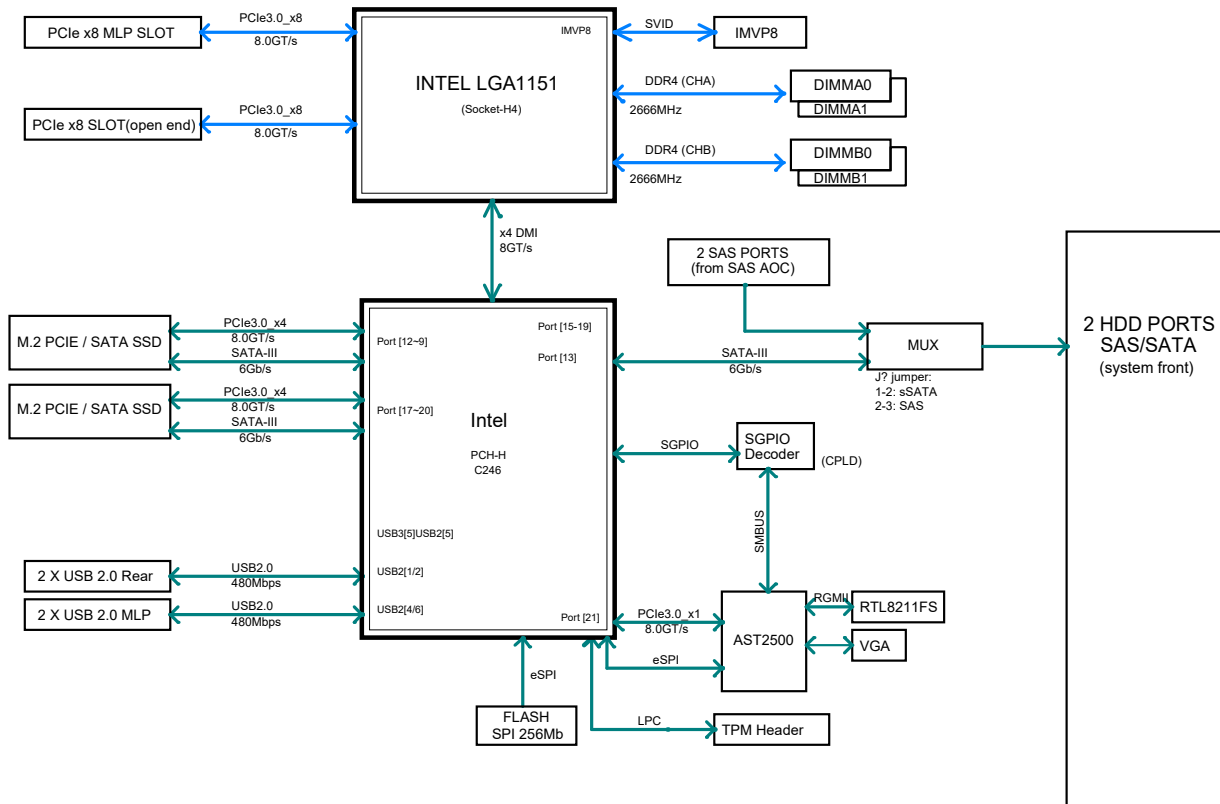

Figure 1-7. System Block Diagram

**Note:** This is a general block diagram and may not exactly represent the features on your motherboard. See the System Specifications appendix for the actual specifications of your motherboard.

## 1.6 Where to Get Replacement Components

If you need replacement parts for your system, to ensure the highest level of professional service and technical support, purchase exclusively from our Supermicro Authorized Distributors/System Integrators/Resellers. A list can be found at: <http://www.supermicro.com>. Click the "Where to Buy" link.

## 1.7 Returning Merchandise for Service

A receipt or copy of your invoice marked with the date of purchase is required before any warranty service will be rendered. You can obtain service by calling your vendor for a Returned Merchandise Authorization (RMA) number. When returning to the manufacturer, the RMA number should be prominently displayed on the outside of the shipping carton, and mailed prepaid or hand-carried. Shipping and handling charges will be applied for all orders that must be mailed when service is complete.

For faster service, RMA authorizations may be requested online (<http://www.supermicro.com/support/rma/>).

Whenever possible, repack the chassis in the original Supermicro carton, using the original packaging material. If these are no longer available, be sure to pack the chassis securely, using packaging material to surround the chassis so that it does not shift within the carton and become damaged during shipping.

This warranty only covers normal consumer use and does not cover damages incurred in shipping or from failure due to the alteration, misuse, abuse, or improper maintenance of products.

During the warranty period, contact your distributor first for any product problems.

# Chapter 2

## Server Installation

### 2.1 Overview

This chapter provides advice and instructions for mounting your system in a server rack.

**Caution:** Electrostatic Discharge (ESD) can damage electronic components. To prevent such damage to PCBs (printed circuit boards), it is important to use a grounded wrist strap, handle all PCBs by their edges, and keep them in anti-static bags when not in use.

### 2.2 Preparing for Setup

The box in which the system was shipped should include the rackmount hardware needed to install it into the rack. Please read this section in its entirety before you begin the installation.

#### Choosing a Setup Location

- The system should be situated in a clean, dust-free area that is well ventilated. Avoid areas where heat, electrical noise, and electromagnetic fields are generated.
- Leave enough clearance in front of the rack so that you can open the front door completely (~25 inches) and approximately 30 inches of clearance in the back of the rack to allow sufficient space for airflow and access when servicing.
- This product should be installed only in a Restricted Access Location (dedicated equipment rooms, service closets, etc.).
- This product is not suitable for use with visual display workplace devices according to §2 of the German Ordinance for Work with Visual Display Units.

#### Rack Precautions

- Ensure that the leveling jacks on the bottom of the rack are extended to the floor so that the full weight of the rack rests on them.
- In single rack installations, stabilizers should be attached to the rack. In multiple rack installations, the racks should be coupled together.

- Always make sure the rack is stable before extending a server or other component from the rack.
- You should extend only one server or component at a time - extending two or more simultaneously may cause the rack to become unstable.

## **Server Precautions**

- Review the electrical and general safety precautions in Appendix B.
- Determine the placement of each component in the rack *before* you install the rails.
- Install the heaviest server components at the bottom of the rack first and then work your way up.
- Use a regulating uninterruptible power supply (UPS) to protect the server from power surges and voltage spikes and to keep your system operating in case of a power failure.
- Allow any drives and power supply modules to cool before touching them.
- When not servicing, always keep the front door of the rack and all covers/panels on the servers closed to maintain proper cooling.

## **Rack Mounting Considerations**

### ***Ambient Operating Temperature***

If installed in a closed or multi-unit rack assembly, the ambient operating temperature of the rack environment may be greater than the room's ambient temperature. Therefore, consideration should be given to installing the equipment in an environment compatible with the manufacturer's maximum rated ambient temperature (TMRA).

### ***Airflow***

Equipment should be mounted into a rack so that the amount of airflow required for safe operation is not compromised.

### ***Mechanical Loading***

Equipment should be mounted into a rack so that a hazardous condition does not arise due to uneven mechanical loading.

### ***Circuit Overloading***

Consideration should be given to the connection of the equipment to the power supply circuitry and the effect that any possible overloading of circuits might have on overcurrent protection and power supply wiring. Appropriate consideration of equipment nameplate ratings should be used when addressing this concern.

### ***Reliable Ground***

A reliable ground must be maintained at all times. To ensure this, the rack itself should be grounded. Particular attention should be given to power supply connections other than the direct connections to the branch circuit (i.e., the use of power strips, etc.).



To prevent bodily injury when mounting or servicing this unit in a rack, you must take special precautions to ensure that the system remains stable. The following guidelines are provided to ensure your safety:

- This unit should be mounted at the bottom of the rack if it is the only unit in the rack.
- When mounting this unit in a partially filled rack, load the rack from the bottom to the top with the heaviest component at the bottom of the rack.
- If the rack is provided with stabilizing devices, install the stabilizers before mounting or servicing the unit in the rack.
- Slide rail mounted equipment is not to be used as a shelf or a work space.

## 2.3 Installing the Rails

There are a variety of rack units on the market, which may require a slightly different assembly procedure. This rail set fits a rack between 26.8" and 36.4" deep.

The following is a basic guideline for installing the system into a rack with the rack mounting hardware provided. You should also refer to the installation instructions that came with the specific rack you are using.

### Identifying the Rails

The chassis package includes two rail assemblies. Each assembly consists of three sections: an inner rail that secures directly to the chassis, an outer rail that secures to the rack, and a middle rail which extends from the outer rail. These assemblies are specifically designed for the left and right side of the chassis and labeled.

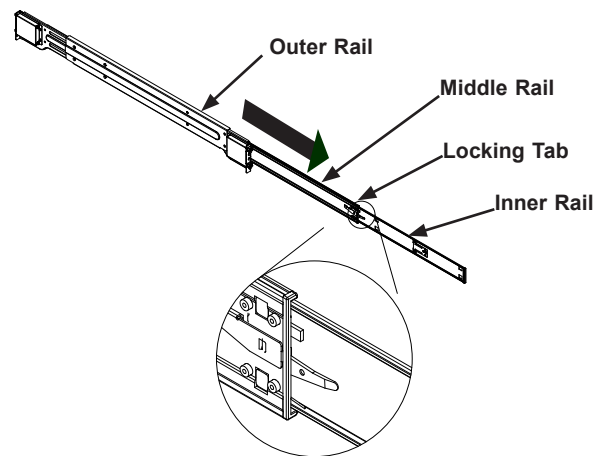

**Figure 2-1. Identifying the Outer Rail, Middle Rail, and Inner Rail**  
(Left Rail Assembly Shown)

## Releasing the Inner Rail

Each inner rail has a locking latch. This latch prevents the server from coming completely out of the rack when the chassis is pulled out for servicing.

To mount the rail onto the chassis, first release the inner rail from the outer rails.

1. Pull the inner rail out of the outer rail until it is fully extended, as illustrated below.
2. Press the locking tab down to release the inner rail.
3. Pull the inner rail all the way out.

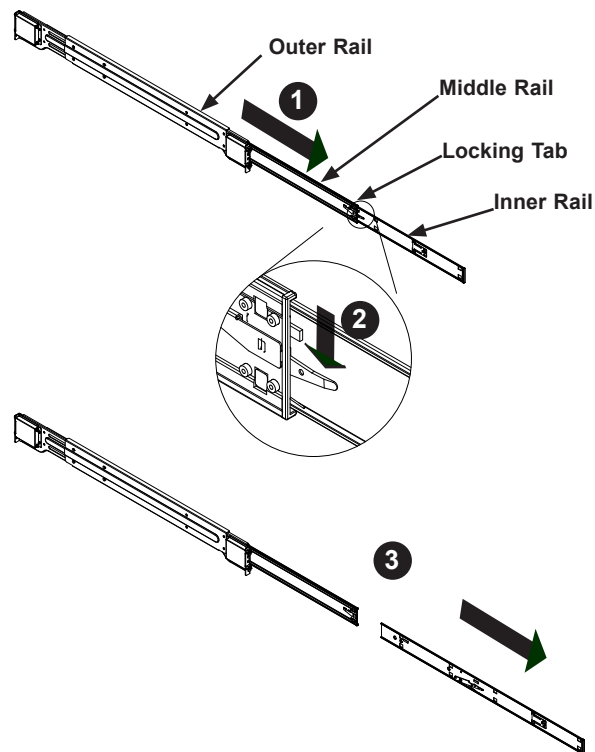

Figure 2-2. Extending and Releasing the Inner Rail

## Installing the Inner Rails on the Chassis

### *Installing the Inner Rails*

1. Identify the left and right inner rails. They are labeled.
2. Place the inner rail firmly against the side of the chassis, aligning the hooks on the side of the chassis with the holes in the inner rail.
3. Slide the inner rail forward toward the front of the chassis until the quick release bracket snaps into place, securing the rail to the chassis.
4. Optionally, you can further secure the inner rail to the chassis with screws.

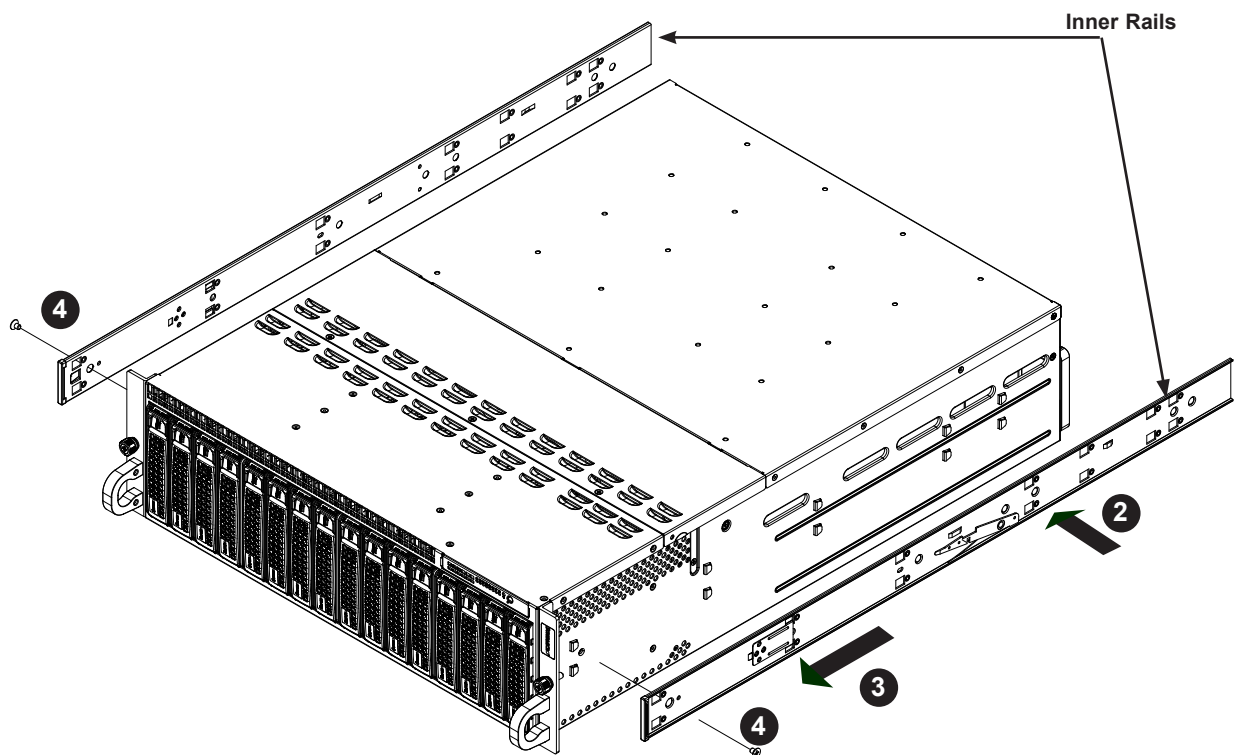

Figure 2-3. Inner Rails Installed on the Chassis

## Installing the Outer Rails onto the Rack

Each end of the assembled outer rail includes a bracket with hooks and spring-loaded pegs to fit into the square holes in your rack.

### *Installing the Outer Rail*

1. Press upward on the locking tab at the rear end of the middle rail.
2. Push the middle rail back into the outer rail.
3. Hang the hooks on the front of the outer rail onto the square holes on the front of the rack. If desired, use screws to secure the outer rails to the rack.
4. Pull out the rear of the outer rail, adjusting the length until it just fits within the posts of the rack.
5. Hang the hooks of the rear section of the outer rail onto the square holes on the rear of the rack. Take care that the proper holes are used so the rails are level. If desired, use screws to secure the rear of the outer rail to the rear of the rack.

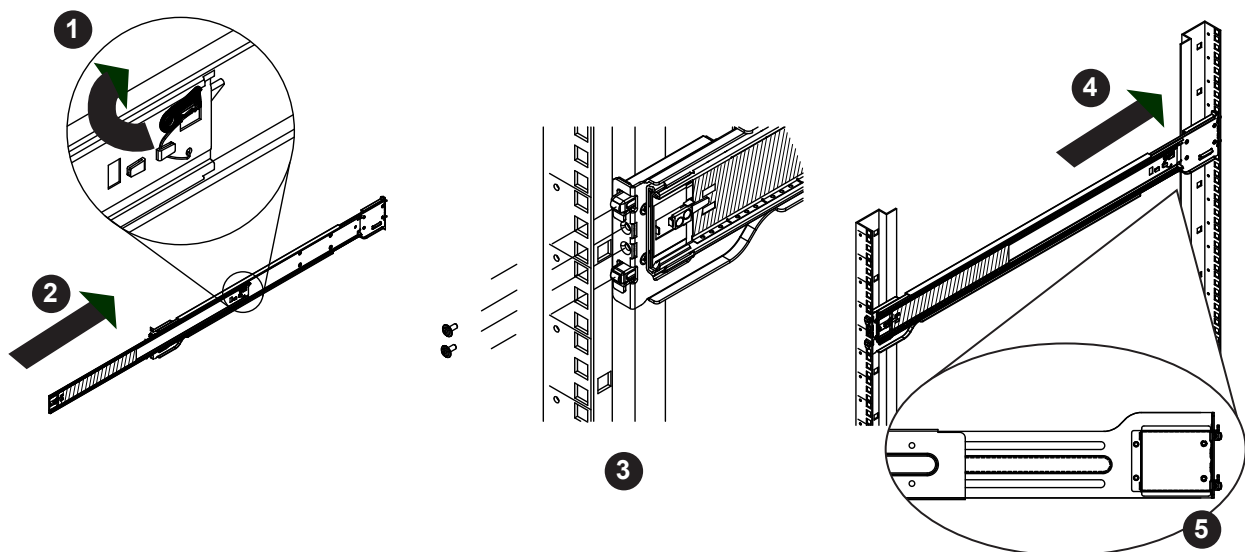

**Figure 2-4. Extending and Mounting the Outer Rails**

**Note:** The figure above is for illustrative purposes only. Always install servers at the bottom of the rack first.



**Stability hazard.** The rack stabilizing mechanism must be in place, or the rack must be bolted to the floor before you slide the unit out for servicing. Failure to stabilize the rack can cause the rack to tip over.



**Warning:** Do not pick up the server with the front handles. They are designed to pull the system from a rack only.

## 2.4 Installing the Chassis into a Rack

Once rails are attached to the chassis and the rack, you can install the server.



**Warning:** Mounting the system into the rack requires at least two people to support the chassis during installation. Please follow safety recommendations printed on the rails.

### *Installing the Chassis into a Rack*

1. Extend the outer rails.
2. Align the inner rails of the chassis with the outer rails on the rack.
3. Slide the inner rails into the outer rails, keeping the pressure even on both sides. When the chassis has been pushed completely into the rack, it should click into the locked position.
4. Optional screws may be used to hold the front of the chassis to the rack.

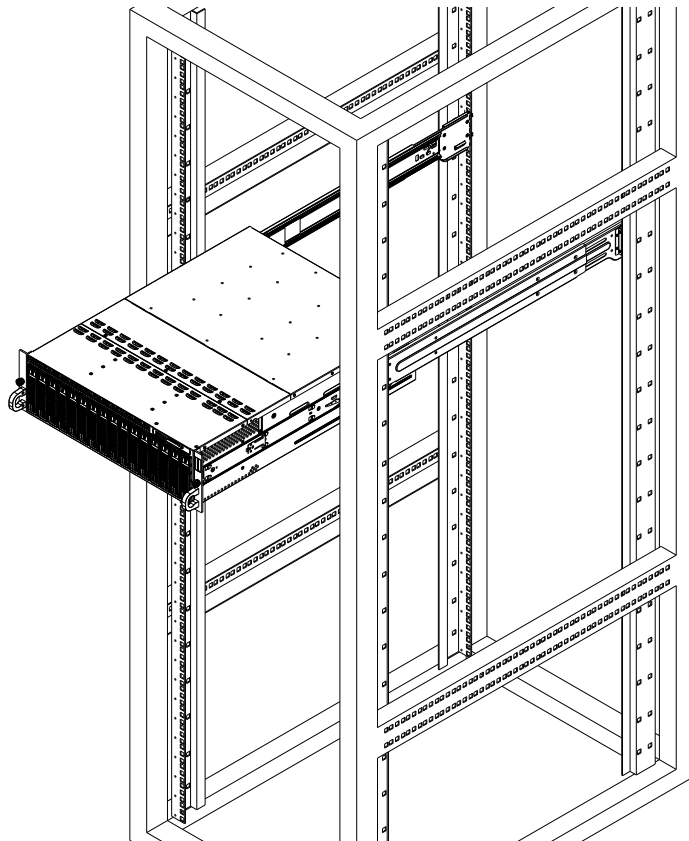

**Figure 2-5. Installing the Server into the Rack**

**Note:** Keep the ball bearing shuttle locked at the front of the middle rail during installation.

**Note:** Figure is for illustrative purposes only. Always install servers to the bottom of a rack first.

## Removing the Chassis from the Rack

**Caution!** The system is heavy. It is dangerous for a single person to remove it from the rack. Have sufficient personnel or use a lift to support the chassis.

1. Pull the chassis forward out the front of the rack until it stops.
2. Press the release latches on each of the inner rails downward simultaneously and continue to pull the chassis forward and out of the rack.

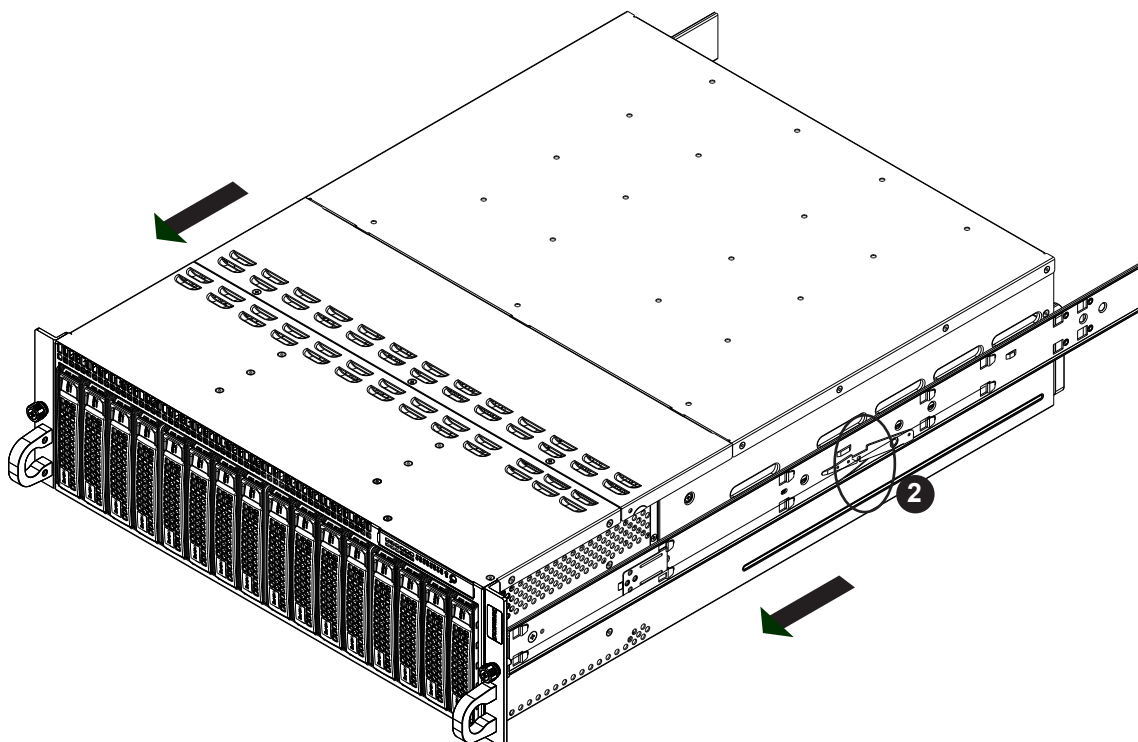

Figure 2-6. Removing the Chassis From the Rack

## Chapter 3

# Maintenance and Component Installation

This chapter provides instructions on installing and replacing main system components. To prevent compatibility issues, only use components that match the specifications and/or part numbers given.

Installation or replacement of most components require that power first be removed from the system. Please follow the procedures given in each section.

### 3.1 Removing Power

Before performing some setup or maintenance tasks, use the following procedure to ensure that power has been removed from the system.

#### ***Removing Power from a Node***

- Use the operating system to power down the node.

#### ***Removing Power from the System***

1. Use the operating system to power down all nodes.
2. Grasp the head of each power cord and gently pull it out of the back of the power supply.
3. Disconnect the cords from the power strip or wall outlet.

## 3.2 Accessing the System

The chassis contains eight computing nodes, each removable from the rear of the chassis while the others continue operating.

### Removing a Computing Node

The two storage drives controlled by the node will power down upon removal.

1. Power down the node using the operating system or the power button.
2. Remove any cables attached to the node.
3. Push down and hold the release latch, then pull the node handle.
4. Slide the node out the chassis rear.

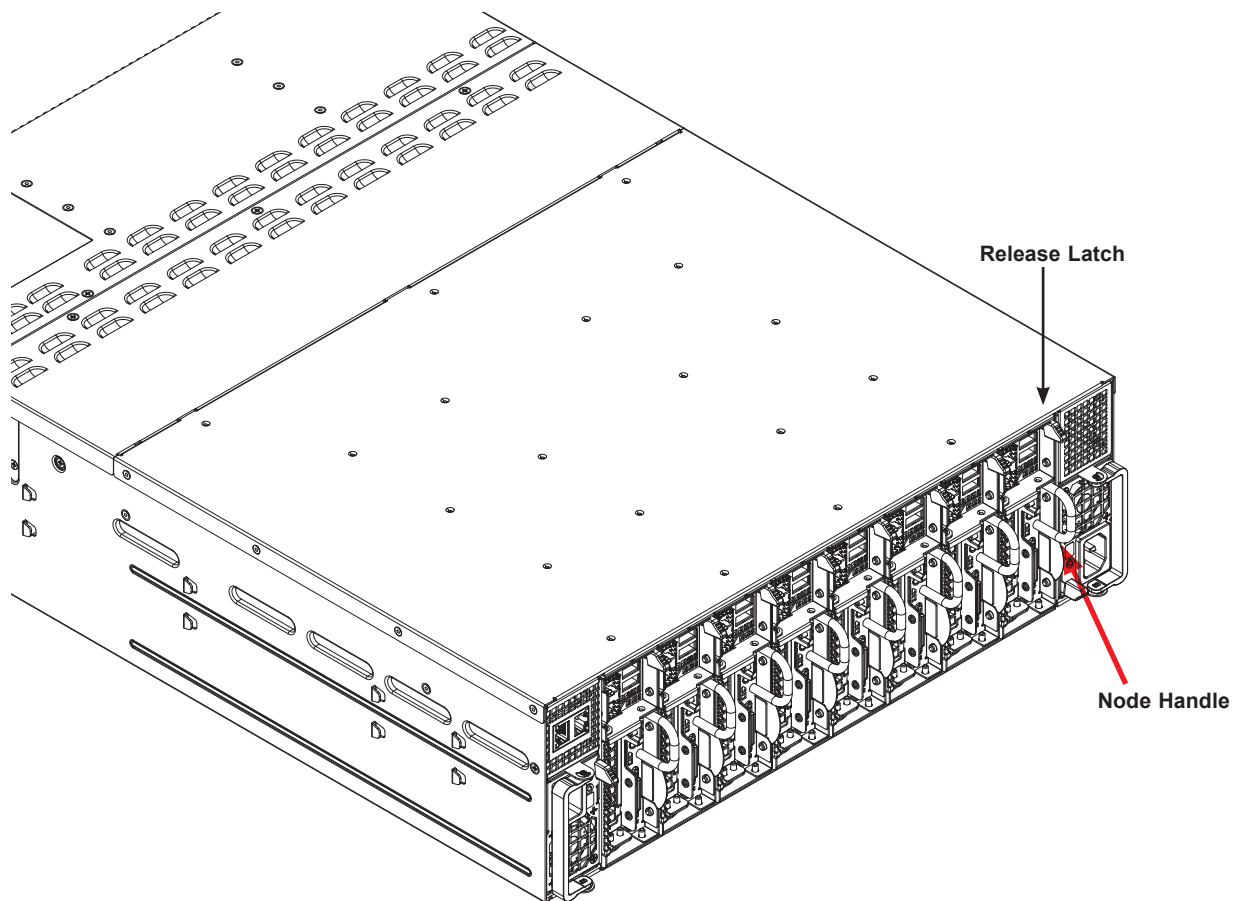

Figure 3-1. Removing a Node

## Removing the Chassis Cover

You can access some chassis components, such as fans, by removing the cover.

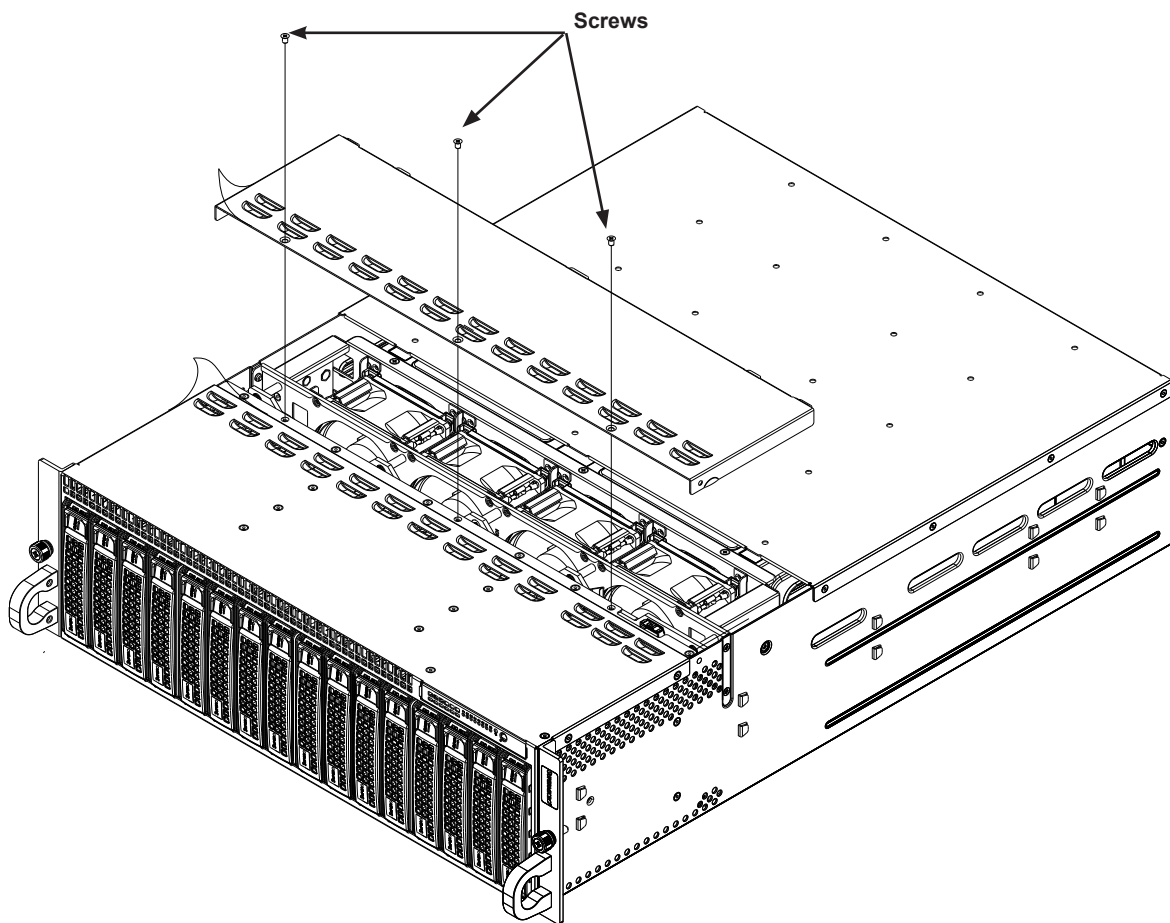

Figure 3-2. Removing the Chassis Cover

### *Removing the Chassis Cover*

The chassis top cover can be lifted off after removing three screws.

**Caution:** Except for short periods of time, do not operate the server without the cover in place. It provides proper airflow to prevent overheating.

## 3.3 Motherboard Components

The processors (CPUs) and heatsinks are installed by the manufacturer.

### Memory

#### *Memory Support*

The X11SCD-F motherboard supports up to 64GB unbuffered ECC with speeds up to 2666MHz in four DIMM slots. Populating the DIMM slots with pairs of memory modules of the same type, speed, and size will result in interleaved memory, which improves performance.

Check the Supermicro website for possible updates to memory support.

#### *DIMM Module Population Configuration*

For optimal memory performance, follow the table below when populating memory.

Recommended Population (Balanced)				
DIMMB2	DIMMA2	DIMMB1	DIMMA1	Total System Memory
4GB	4GB			8GB
4GB	4GB	4GB	4GB	16GB
8GB	8GB			16GB
8GB	8GB	8GB	8GB	32GB
16GB	16GB			32GB
16GB	16GB	16GB	16GB	64GB
32GB	32GB			64GB
32GB	32GB	32GB	32GB	128GB

### ***DIMM Module Population Sequence***

When installing memory modules, the DIMM slots must be populated in the following order: DIMMB2, DIMMA2, then DIMMB1 and DIMMA1. The blue slots must be populated first.

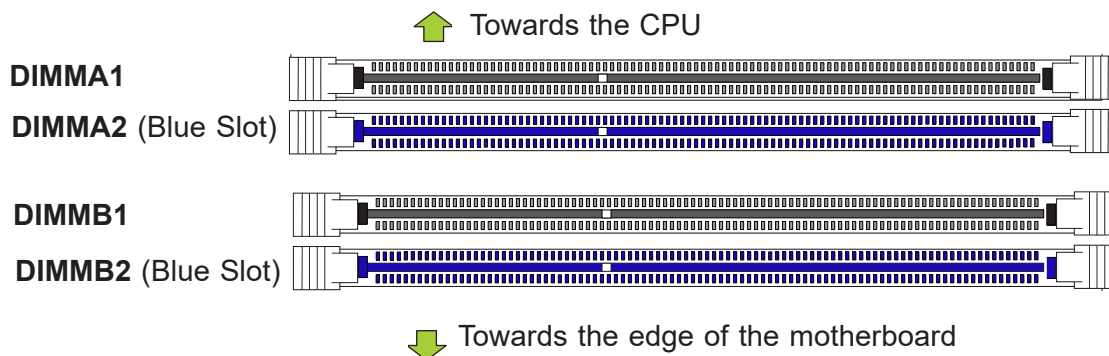

**Note:** Be sure to use memory modules of the same type and speed on the motherboard. Mixing of memory modules of different types and speeds is not allowed.

## Install Procedure

### Installing Memory

#### ESD Precautions

Electrostatic Discharge (ESD) can damage electronic components, including memory modules. To avoid damaging DIMM modules, it is important to handle them carefully. The following measures are generally sufficient.

- Use a grounded wrist strap designed to prevent static discharge.
- Handle the memory module by its edges only.
- Put the memory modules into the antistatic bags when not in use.

#### Installing Memory

Begin by removing power from the system as described in Section 3.1. Follow the memory population sequence in the table above.

1. Push the release tabs outwards on both ends of the DIMM slot to unlock it.

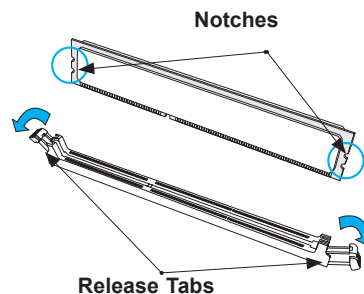

2. Align the key of the DIMM with the receptive point on the memory slot and with your thumbs on both ends of the module, press it straight down into the slot until the module snaps into place.

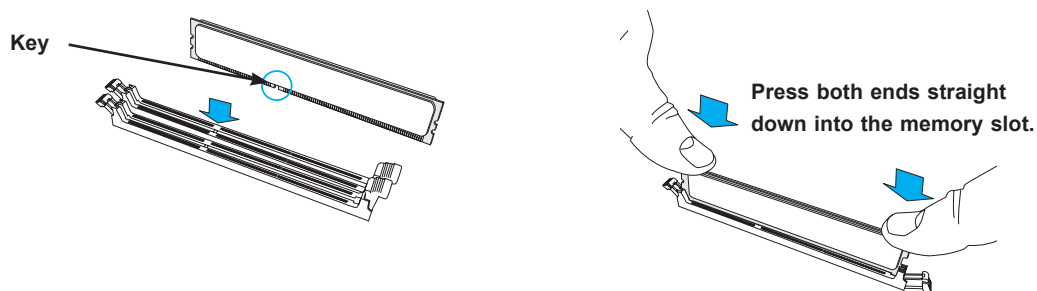

3. Press the release tabs to the locked position to secure the DIMM module into the slot.

**Caution:** Exercise extreme caution when installing or removing memory modules to prevent damage to the DIMMs or slots.

### Removing Memory

To remove a DIMM, unlock the release tabs then pull the DIMM from the memory slot.

## Expansion Module

Each of the eight nodes includes a single MicroLP expansion module providing two LAN connections. Currently, there are four supported for the 5039MC-H8TRF system:

- One PCI-E 3.0 x8 open end slot
- One MicroLP slot (MicroLP upgradeable)
- Two M.2 PCI-E 3.0 x4 slot with SATA3 support, M-Key 2280, 22110

The MicroLP expansion module is inserted into a riser card and secured to two brackets as shown below. This assembly is inserted into the expansion slot on the motherboard and the rear bracket is secured to the rear of the node chassis.

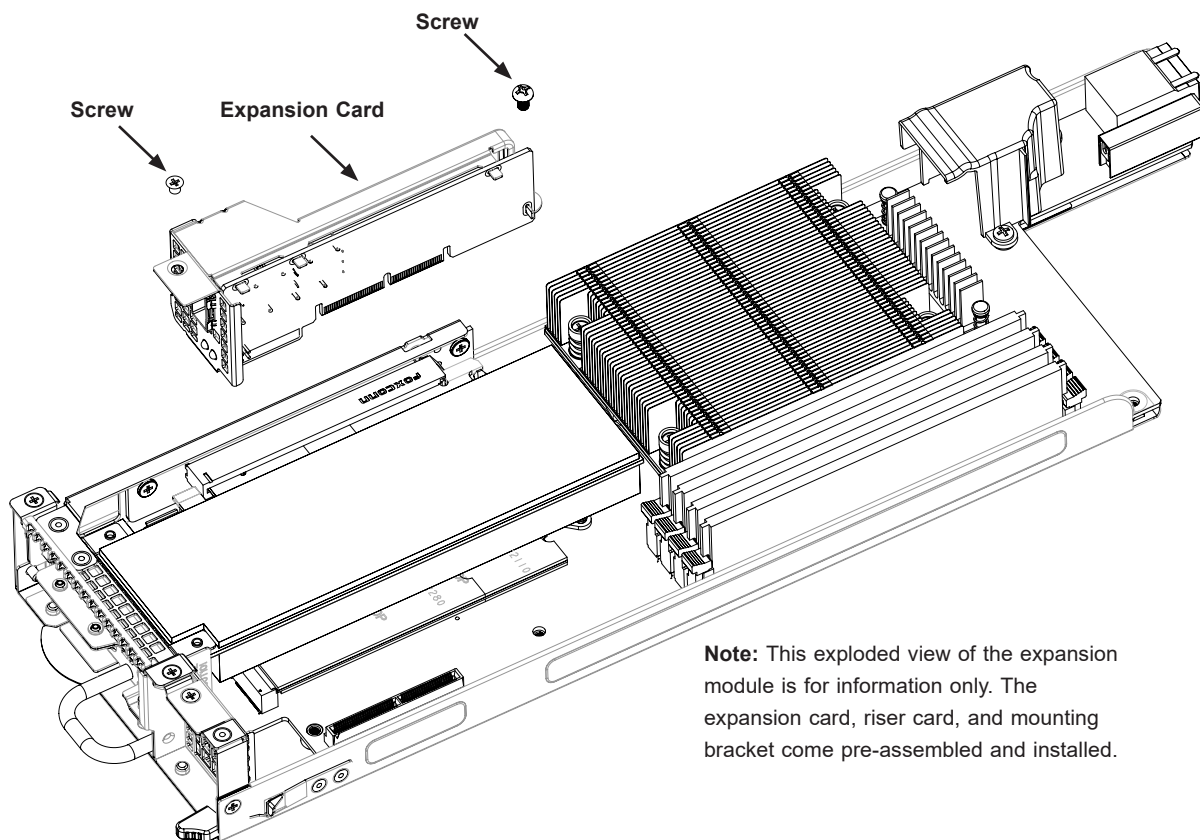

**Figure 3-3. MicroLP Expansion Module Assembly**

## Motherboard Battery

The motherboard uses non-volatile memory to retain system information when system power is removed. This memory is powered by a lithium battery residing on the motherboard.

### *Replacing the Battery*

Begin by removing power from the system as described in section 3.1.

1. Push aside the small clamp that covers the edge of the battery. When the battery is released, lift it out of the holder.
2. To insert a new battery, slide one edge under the lip of the holder with the positive (+) side facing up. Then push the other side down until the clamp snaps over it.

**Note:** Handle used batteries carefully. Do not damage the battery in any way; a damaged battery may release hazardous materials into the environment. Do not discard a used battery in the garbage or a public landfill. Please comply with the regulations set up by your local hazardous waste management agency to dispose of your used battery properly.

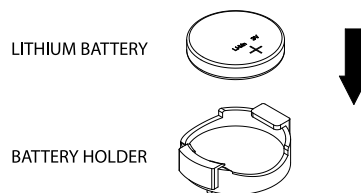

**Figure 3-4. Installing the Onboard Battery**

**Warning:** There is a danger of explosion if the onboard battery is installed upside down (which reverses its polarities). This battery must be replaced only with the same or an equivalent type recommended by the manufacturer (CR2032).

## 3.4 Chassis Components

This section provides instructions on installing and replacing system components. To assure compatibility, only use components that match the specifications or part numbers given.

### Corresponding Nodes, Fans and Hard Drives

The SC938BH-R1620B chassis contains eight individual nodes each containing a motherboard. Each node controls two storage drives and shares a fan with the node beside it. If a node is pulled out of the chassis, the associated drives will power-down.

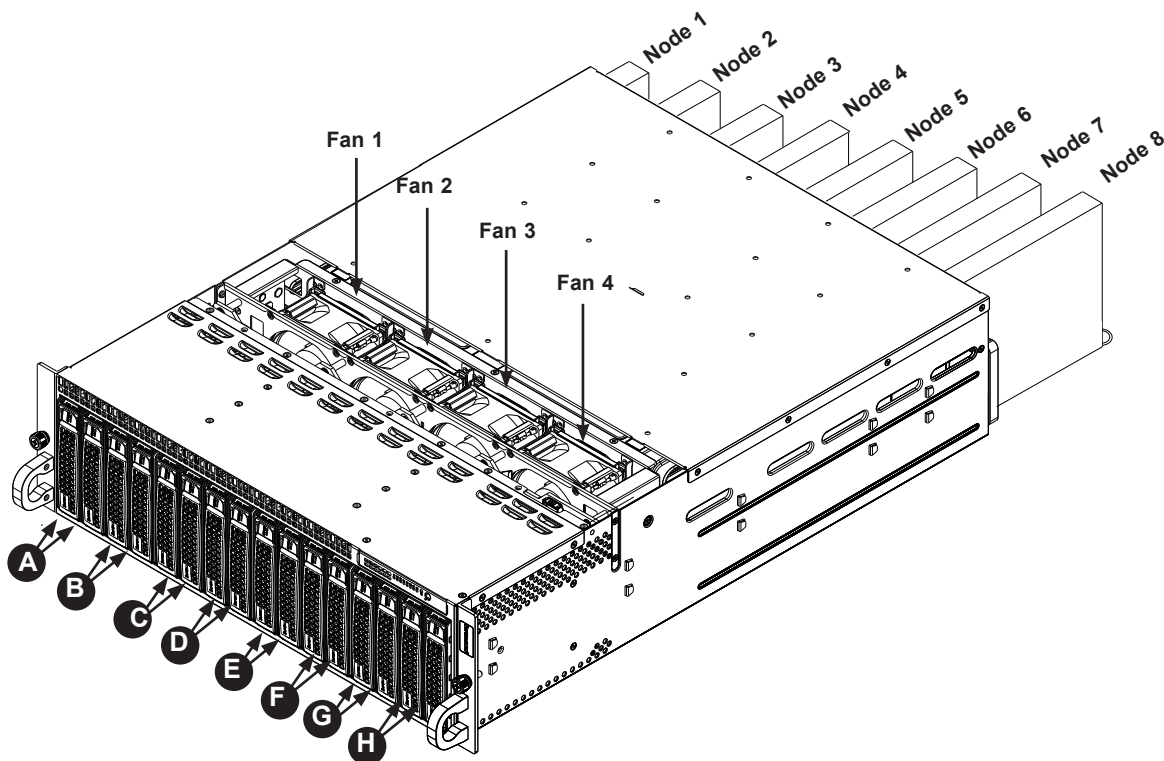

**Figure 3-5. Corressponding Nodes, Fans and Drives**

Node	Fan	Drives
Node 1	Fan 1	Storage drives A1 and A2
Node 2	Fan 1	Storage drives B1 and B2
Node 3	Fan 2	Storage drives C1 and C2
Node 4	Fan 2	Storage drives D1 and D2
Node 5	Fan 3	Storage drives E1 and E2
Node 6	Fan 3	Storage drives F1 and F2
Node 7	Fan 4	Storage drives G1 and G2
Node 8	Fan 4	Storage drives H1 and H2

## Storage Drives

The system supports sixteen 3.5" hot-swap storage drives, SATA3 by default. Optional adapter kits allow 2.5" NVMe/SATA drives instead. The drives are mounted in drive carriers that simplify their removal from the chassis. These carriers also help promote proper airflow. Even carriers without drives must remain in the chassis for proper airflow.

### Drive Carrier Indicators

Each drive carrier has two LED indicators: an activity indicator and a status indicator. For RAID configurations using a controller, the meaning of the status indicator is described in the table below. For OS RAID or non-RAID configurations, some LED indications are not supported, such as hot spare.

Drive Carrier LED Indicators			
	Color	Blinking Pattern	Behavior for Device
Activity LED	Blue	Solid On	SAS/NVMe drive installed
	Blue	Blinking	I/O activity
Status LED	Red	Solid On	Failure of drive with RSTe support
	Red	Blinking at 1 Hz	Rebuild drive with RSTe support
	Red	Blinking with two blinks and one stop at 1 Hz	Hot spare for drive with RSTe support <i>(not supported in VMD mode)</i>
	Red	On for five seconds, then off	Power on for drive with RSTe support
	Red	Blinking at 4 Hz	Identify drive with RSTe support
	Green	Solid On	Safe to remove NVMe device <i>(not supported in VMD mode)</i>
	Amber	Blinking at 1 Hz	Attention state—do not remove NVMe device <i>(not supported in VMD mode)</i>

**Note:** Enterprise level hard disk drives are recommended for use in Supermicro chassis and servers. For information on recommended HDDs, visit the Supermicro website at <https://www.supermicro.com/products/nfo/files/storage/SBB-HDDCompList.pdf>.

**Removing a Hot-Swap Drive Carrier from the Chassis**

1. Press the release button on the drive carrier, which will extend the drive carrier handle.
2. Use the drive carrier handle to pull the drive out of the chassis.

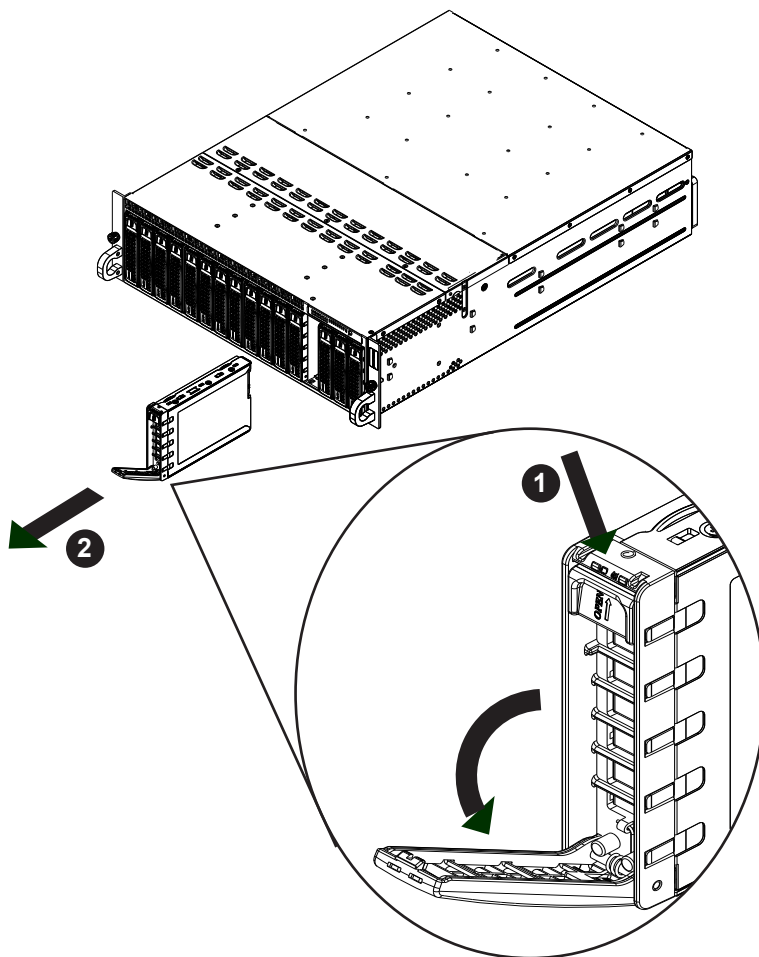
**Figure 3-6. Removing a Drive Carrier**

### ***Removing a Hot-Swap Drive Carrier from the Chassis***

1. Press the release button on the drive carrier, which will extend the drive carrier handle.
2. Use the drive carrier handle to pull the drive out of the chassis.

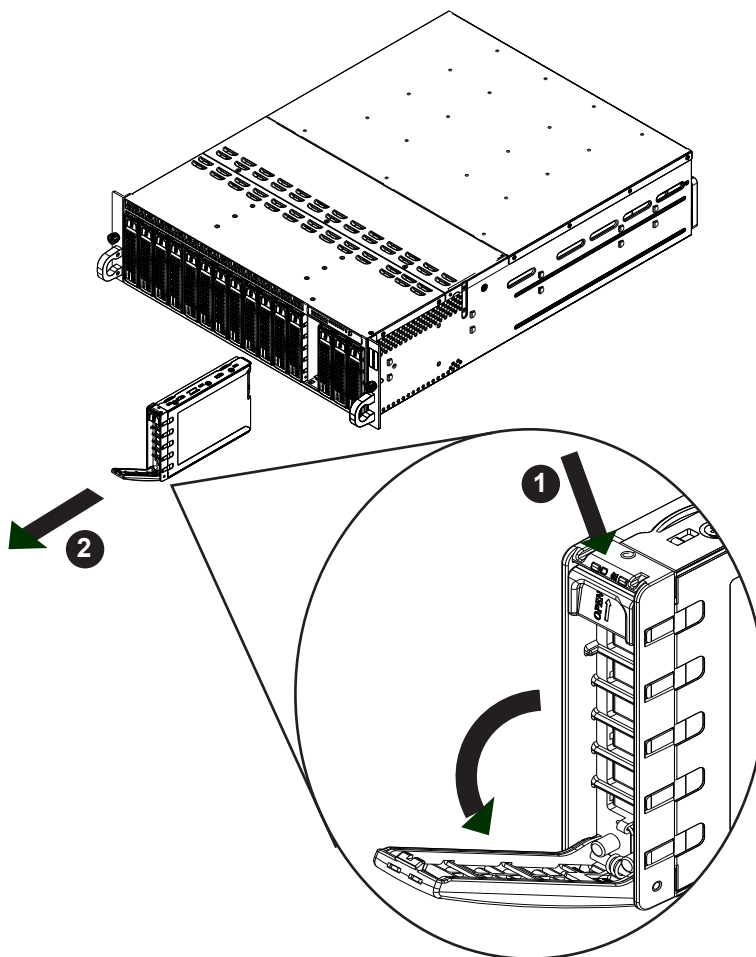

**Figure 3-7. Removing a Drive Carrier**

### ***Installing a Drive***

1. Remove the dummy drive, which comes pre-installed in the drive carrier, by removing the screws securing the dummy drive to the carrier. These screws are not used to mount the actual drive.

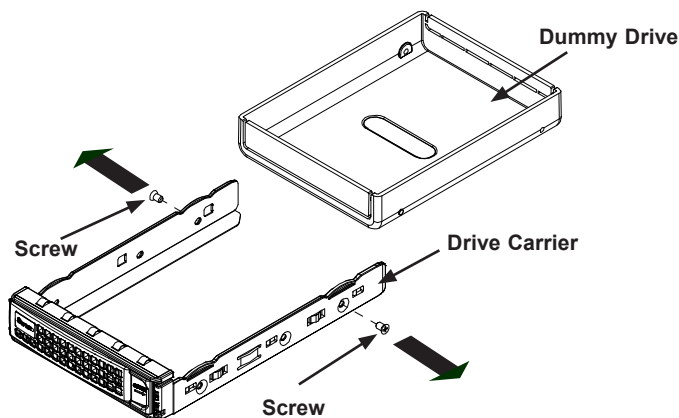

**Figure 3-8. Removing the Dummy Drive from a Carrier**

2. Insert a drive into the carrier with the PCB side facing down and the connector end toward the rear of the carrier. Align the drive in the carrier so that the screw holes line up. Note that there are holes in the carrier marked "SATA" to aid in correct installation.
3. Secure the drive to the carrier with two M3 screws. These screws are included in the chassis accessory box.
4. Insert the drive carrier with the disk drive into its bay, keeping the carrier oriented so that the hard drive is on the top of the carrier and the release button is on the right side. When the carrier reaches the rear of the bay, the release handle will retract.
5. Push the handle in until it clicks into its locked position.

## Checking the Temperature of an NVMe M.2 Drive

### Checking an NVMe M.2 drive using IPMI

- **IPMI > Server Health > Sensor Reading > M2NVMeSSD Temp1/2** – Shows the temperatures of all NVMe M.2 drives.

### M.2 Solid State Drives

Up to two M.2 solid state drives (SSDs) can be installed in socket J2 and J3 (see Section 1.5).

- M.2 Interface: 2 PCI-E 3.0 x4
- M.2 Form Factor: 2280/22110
- M.2 Key: M-Key

### Installing an M.2 SSD

**Caution:** Use industry-standard anti-static equipment, such as gloves or wrist strap, and follow precautions to avoid damage caused by ESD.

Locate the socket J2 and J3 on the motherboard. There is a plastic standoff in one of the SRW holes. If it is the correct hole for your M.2 SSD, you can slide the SSD into the socket, and secure it by pushing the plug into the standoff. If not, you must move the plastic standoff.

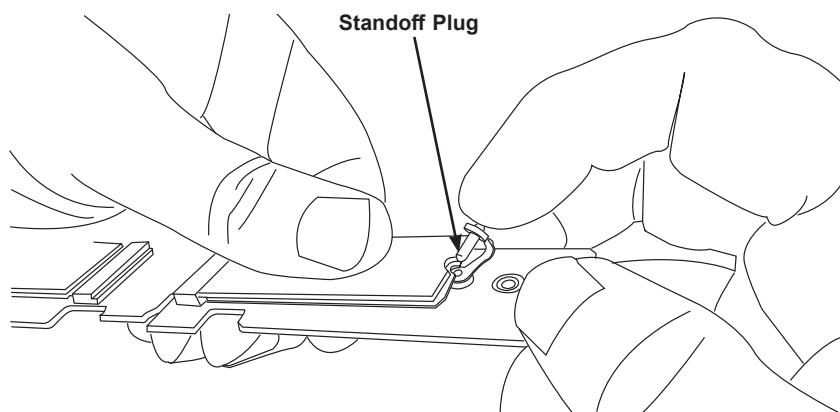

**Figure 3-9. Inserting the Standoff Plug**

(**Note:** Your card looks different, but the standoff functions the same.)

## System Cooling

### *Fans*

The chassis contains four 8-cm high-performance fans. Fan speed is controlled by IPMI depending on the system temperature. If a fan fails, the remaining fans will ramp up to full speed. The system will continue to run with a failed fan, although it may shut down if the heat gets too great. Replace any failed fan at your earliest convenience with the same model. Failed fans can be identified through the IPMI.

### *Changing a System Fan*

1. Determine which fan has failed using IPMI, or if necessary, open the chassis while the system is running. Never run the server for long without the chassis cover.
2. Squeeze both release tabs on the top of the fan module and pull it out.
3. Replace the failed fan with an identical fan, available from Supermicro. Push the new fan into the housing, making sure the air flow direction is the same.
4. Power up the system and check that the fan is working properly and that the LED on the control panel has turned off. Finish by replacing the chassis cover.

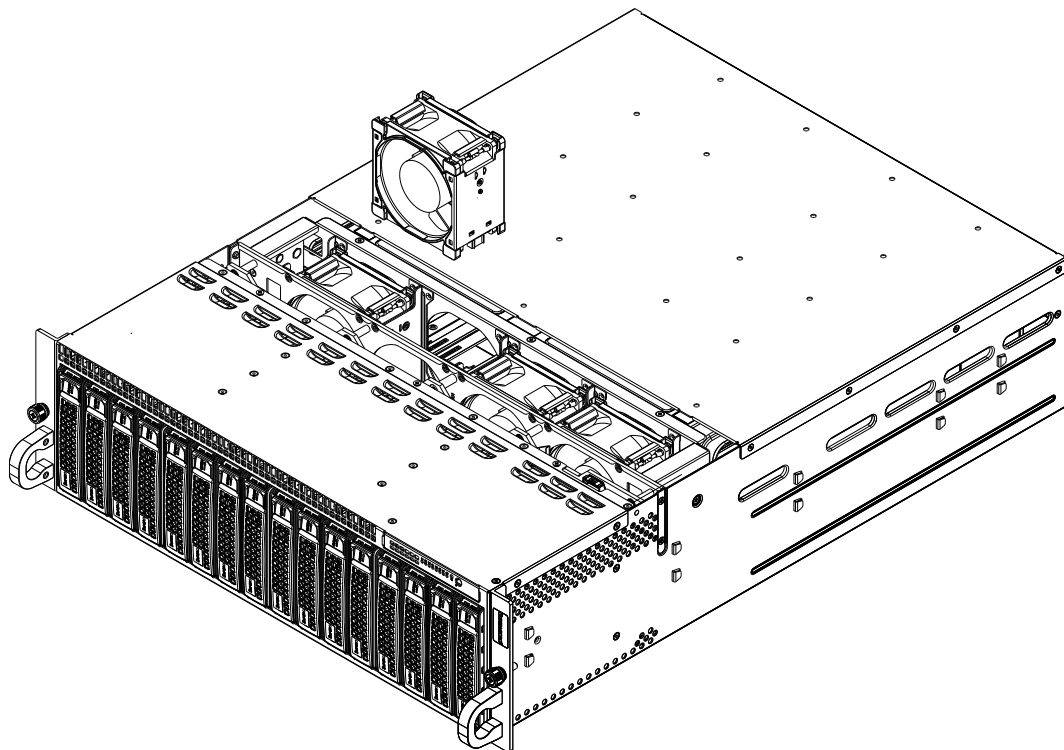

Figure 3-10. Replacing a Fan

### ***Installing the Air Shroud***

Air shrouds and air blocks concentrate airflow to maximize fan efficiency. Air block is pre-installed and may be uninstalled by removing the two screws.

### ***Installing the Air Shroud***

1. Power down the node and remove it. If an expansion card is used, install it first.
2. Place the Mylar air shroud over the two DIMMs, as shown below. The air shroud sits behind the CPU heatsink and goes over the top of the DIMMs.

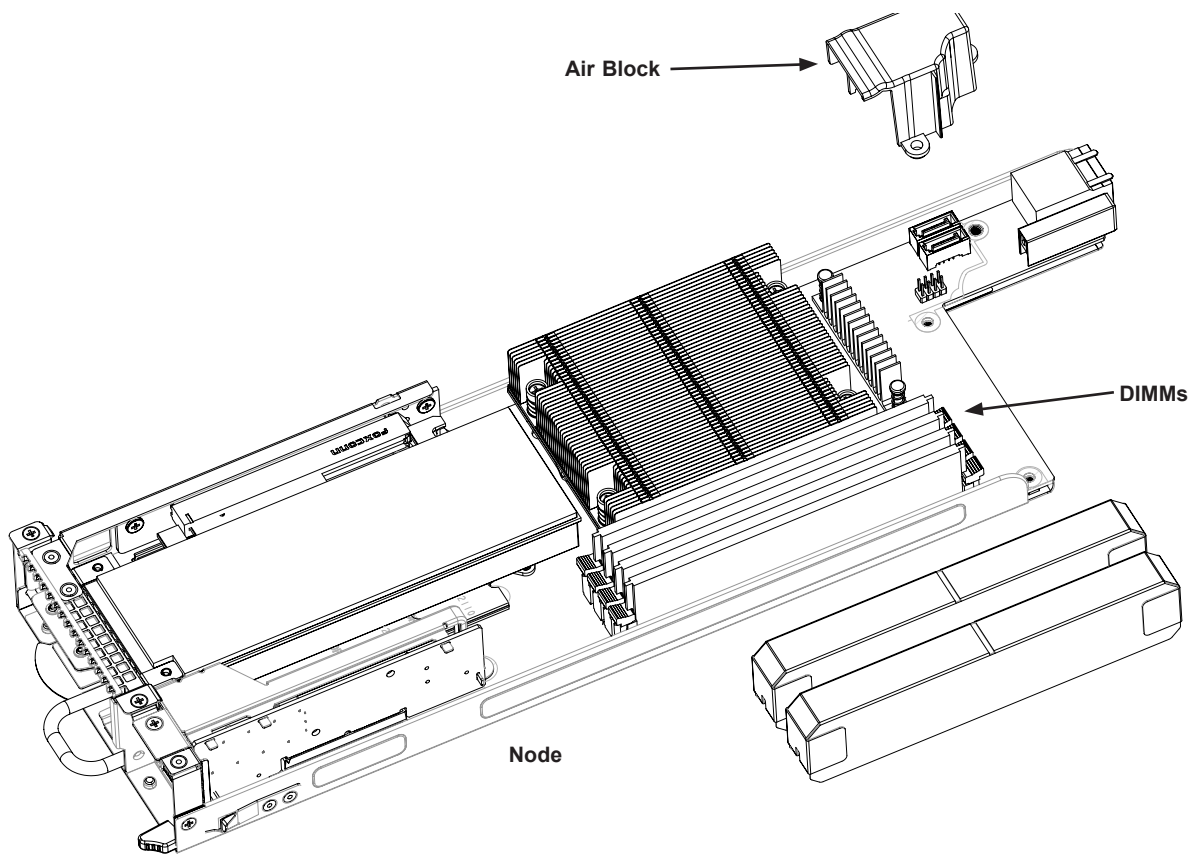

**Figure 3-11. Installing the Air Shroud**

## Power Supply

The chassis features redundant power supplies. They are hot-swappable, meaning they can be changed without powering down the system. New units can be ordered directly from Supermicro or authorized distributors.

These power supplies are auto-switching capable. This feature enables them to automatically sense the input voltage and operate at a 100-120v or 180-240v. An amber light will be illuminated on the power supply when the power is off. An illuminated green light indicates that the power supply is operating.

### *Changing the Power Supply*

1. With the system running, unplug the AC power cord that provides power to the failed module.
2. Press and hold the release tab on the front, top of the power module.
3. Grasp the handle and pull the power supply out of its bay.
4. Push the replacement power supply module into the empty bay until it clicks into the locked position.
5. Plug the AC power cord back into the power supply module.

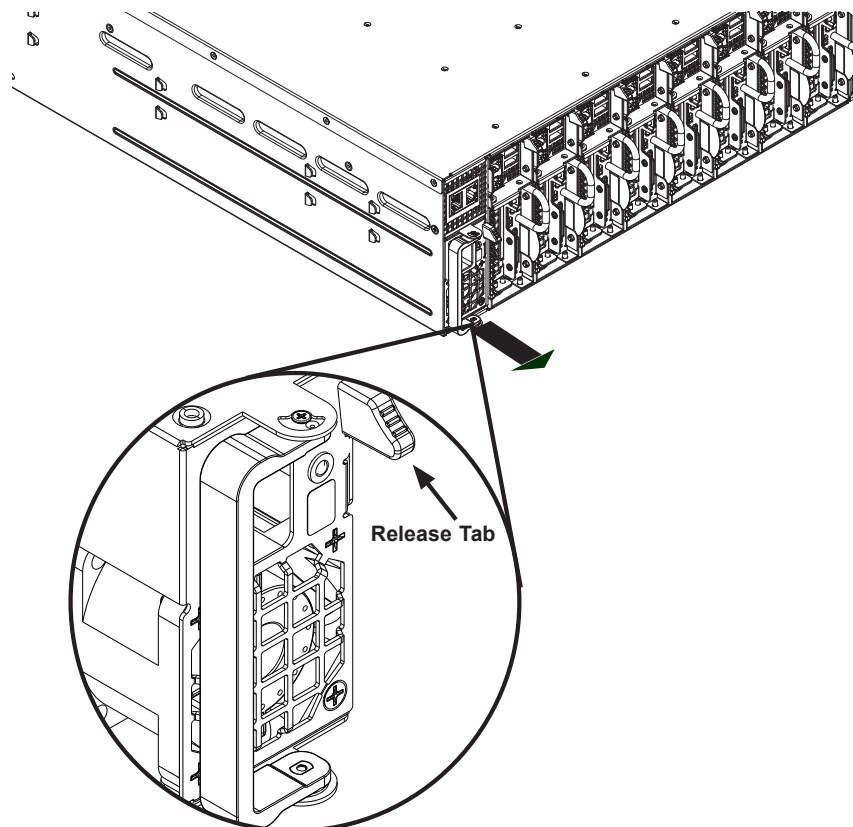

**Figure 3-12. Replacing a Power Supply Module**

## PCI Expansion Cards

The system supports one low-profile PCI-E card in each of the eight nodes with the included riser card (RSC-RR1U-E16).

### *Installing an Expansion Card*

1. Power-down the node and remove it.
2. Remove the three screws that secure the PCI bracket to the motherboard tray.
3. Remove the PCI slot bracket.
4. Remove the PCI slot shield.

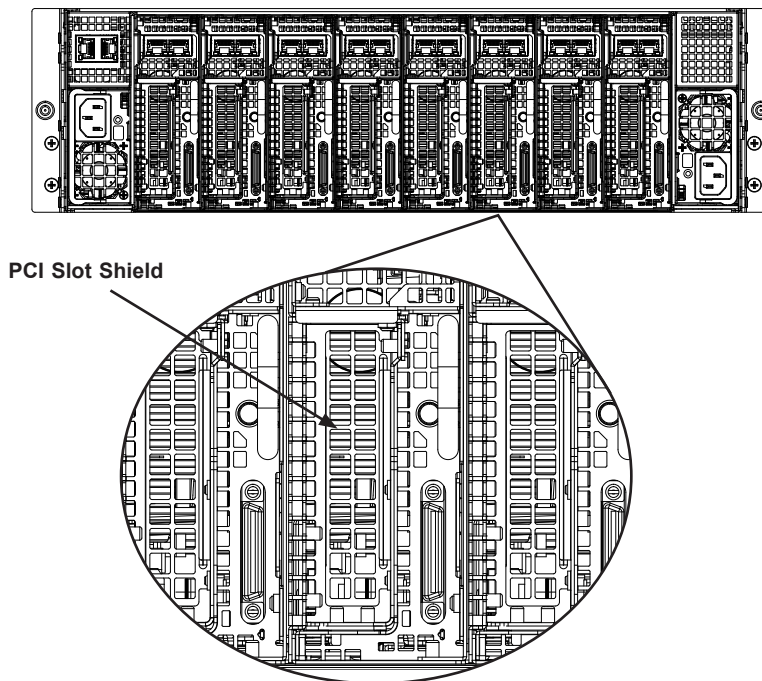

**Figure 3-13. PCI Expansion Card Chassis Slots**

5. Insert the expansion card into the riser card, which is pre-installed on the motherboard (if desired, the riser card may be removed from the motherboard by removing the riser card screw).
6. Slide the add-on cards bracket into the PCI card slot and fit it with the opening in the rear of the node.
7. Close the PCI card slot clip to secure the add-on card.

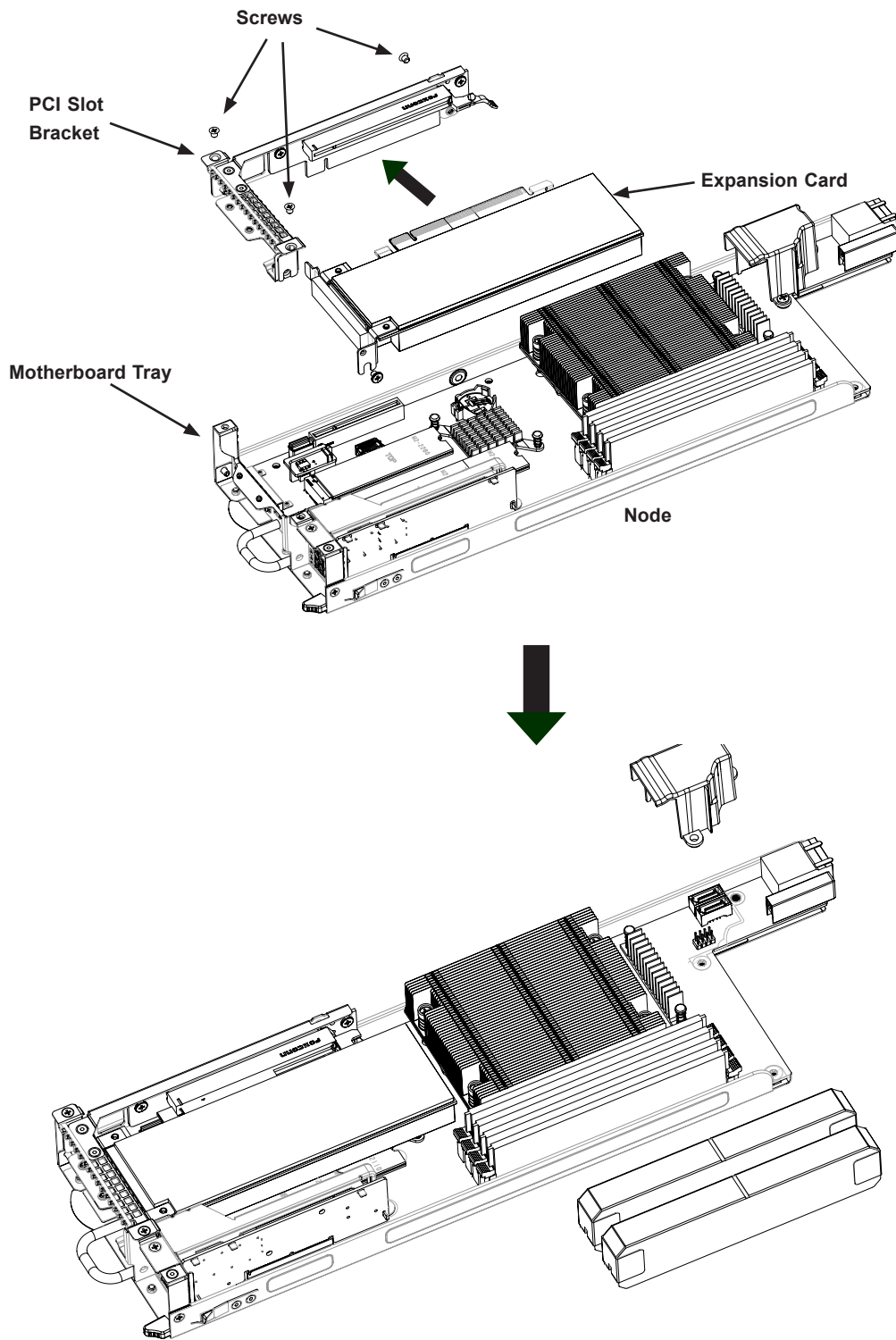

Figure 3-14. Installing an Expansion Card Chassis Slots

## Chapter 4

# Motherboard Connections

This section describes the connections on the motherboard and provides pinout definitions. Note that depending on how the system is configured, not all connections are required. The LEDs on the motherboard are also described here. A motherboard layout indicating component locations may be found in Chapter 1.

Please review the safety precautions in Appendix B before installing or removing components.

### 4.1 Power Connections

#### Power Connector

Connect a 2-pin power supply cable to JPWR1 to provide power to the motherboard.

Power Connector Pin Definitions	
Pin#	Definition
1	Ground
2	P12V

Required Connection

### 4.2 Headers and Connectors

#### TPM Header

The JTPM1 header is used to connect a Trusted Platform Module (TPM)/Port 80, which is available from a third-party vendor. A TPM/Port 80 connector is a security device that supports encryption and authentication in hard drives. It allows the motherboard to deny access if the TPM associated with the hard drive is not installed in the system.

Please go to the following link for more information on TPM: <http://www.supermicro.com/manuals/other/TPM.pdf>.

Trusted Platform Module Header Pin Definitions			
Pin#	Definition	Pin#	Definition
1	+3.3V	2	SPI_CS#
3	RESET#	4	SPI_MISO
5	SPI_CLK	6	GND
7	SPI_MOSI	8	
9	+3.3V Stby	10	SPI_IRQ#

## SAS Ports

The X11SCD-F motherboard has two Serial Attached SCSI 3.0 ports (SAS0 and SAS1).

## M.2 Slot

There are two M.2 slots on the motherboard. M.2 is formerly known as Next Generation Form Factor (NGFF). They are designed for internal mounting devices and provide M-Key 2280/22110 support dedicated for SSD devices with the PCI-E 3.0 x4 or SATA 3 interface.

## I-SATA 3.0 Ports

The X11SCD-F has two I-SATA 3.0 ports (I-SATA1 - I-SATA4) through the backplane that are supported by the Intel C246 chipset.

## Power Switch

Press the power switch at SW2 to turn on the motherboard.

## SGPIO Header

The S-SGPIO1 (Serial General Purpose Input/Output) header is used to communicate with SAS AOC.

SGPIO Header Pin Definitions			
Pin#	Definition	Pin#	Definition
1	NC	2	DATA In
3	SAS_SEL	4	DATA Out
5	Load	6	Ground
7	Clock	8	NC

## I<sup>2</sup>C Bus for VRM

Jumper JVR1 is used for VRM tool programming. JVRM1 allows the BMC or the PCH to access CPU and memory VRM controllers.

VRM Jumper Settings	
Jumper Setting	Definition
Pins 1-2	BMC (Normal)
Pins 2-3	PCH

## 4.3 Rear Input/Output Ports

### Rear I/O Ports

The rear of each node offers two RJ45 Gb Ethernet LAN ports, control switches, and a KVM port.

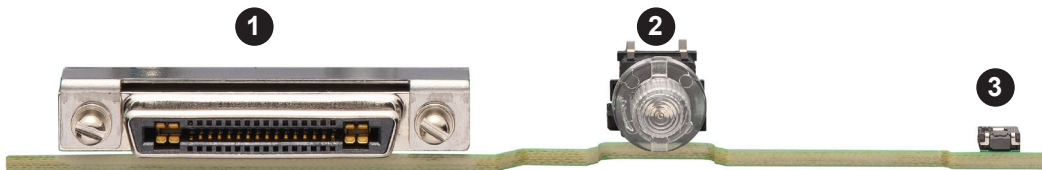

Figure 4-1. Rear I/O Ports

Rear I/O Ports	
Item	Description
1	JKVM1
2	SW2
3	JUIDB1

### KVM1 Connector

The JKVM1 connector is an acronym for Keyboard, Video, and Mouse. The connector supports a set of keyboard, monitor, and mouse to control multiple computers. It also provides a VGA connection, COM1, and two USB 2.0 connections (USB0/1).

### COM Port

The motherboard has one COM port header to provide a serial connection.

COM Port Pin Definitions			
Pin#	Definition	Pin#	Definition
1	SP_DCDA	6	SP_DSRA
2	SP_RXDA	7	SP_RTSA
3	SP_TXDA	8	SP_STSA
4	SP_DTRA	9	SP_RIA
5	GND	10	NC

## VGA Port

A VGA port is located on the I/O back panel. Use this port to connect to a compatible VGA display.

## Universal Serial Bus (USB) Header

There are two USB 2.0 ports (USB0/1) on the motherboard. Type A front access connection with a cable (not included).

Front Panel USB 2.0 Header Pin Definitions			
Pin#	Definition	Pin#	Definition
1	+5V	2	+5V
3	USB_PN2	4	USB_PN3
5	USB_PP2	6	USB_PP3
7	Ground	8	Ground
9	Key	10	Ground

## Unit Identifier Button/UID LED Indicator

A Unit Identifier (UID) switch and an LED indicator are located on the motherboard. The UID switch is located at JUIDB1. The UID LED is located at LED2, next to the UID button. When you press the UID button, the UID LED will be turned on. Press the UID button again to turn off the LED indicator. The LED indicator provides easy identification of a system unit that may be in need of service.

**Note:** UID can also be triggered via IPMI on the motherboard. For more information on IPMI, please refer to the IPMI User's Guide posted on our website at <https://www.supermicro.com/support/manuals/>.

UID Button Pin Definitions	
Pin#	Definition
1	Ground
2	Ground
3	Button In
4	Button In

## 4.4 Jumpers

### *Explanation of Jumpers*

To modify the operation of the motherboard, jumpers are used to choose between optional settings. Jumpers create shorts between two pins to change the function associated with it. Pin 1 is identified with a square solder pad on the printed circuit board. See the motherboard layout page for jumper locations.

**Note:** On a two-pin jumper, "Closed" means the jumper is on both pins and "Open" indicates the jumper is either on only one pin or has been completely removed.

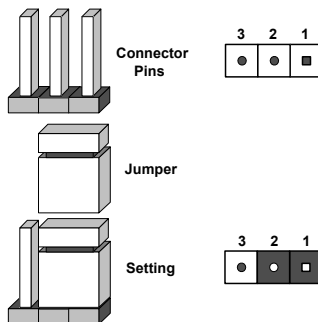

### **CMOS Clear**

JBT1 is used to clear CMOS, which will also clear any passwords. Instead of pins, this jumper consists of contact pads to prevent accidentally clearing the contents of CMOS.

#### **To Clear CMOS**

1. First power down the system and unplug the power cord(s).
2. Remove the cover of the chassis to access the motherboard.
3. Remove the onboard battery from the motherboard.
4. Short the CMOS pads with a metal object such as a small screwdriver for at least four seconds.
5. Remove the screwdriver (or shorting device).
6. Replace the cover, reconnect the power cord(s) and power on the system.

**Notes:** Clearing CMOS will also clear all passwords.

*Do not use the PW\_ON connector to clear CMOS.*



### ME Manufacturing Mode

Close JPME2 to bypass SPI flash security and force the system to use the Manufacturing Mode, which will allow the user to flash the system firmware from a host server to modify system settings. Refer to the table below for jumper settings.

Manufacturing Mode Jumper Settings	
Jumper Setting	Definition
Pins 1-2	Normal (Default)
Pins 2-3	Manufacturing Mode

### VGA Enable/Disable

Use jumper JPG1 to enable or disable the VGA port using the onboard graphics controller. The default setting is Enabled.

VGA Enable/Disable Jumper Settings	
Jumper Setting	Definition
Pins 1-2	Enabled
Pins 2-3	Disabled

### Watch Dog

JWD1 controls the Watch Dog function. Watch Dog is a monitor that can reboot the system when a software application hangs. Jumping pins 1-2 will cause Watch Dog to reset the system if an application hangs. Jumping pins 2-3 will generate a non-maskable interrupt signal for the application that hangs. Watch Dog must also be enabled in BIOS. The default setting is Reset.

**Note:** When Watch Dog is enabled, users need to write their own application software to disable it.

Watch Dog Jumper Settings	
Jumper Setting	Definition
Pins 1-2	Reset (Default)
Pins 2-3	NMI
Open	Disabled

## 4.5 LED Indicators

### Onboard Power LED

The Onboard Power LED indicator is located at SW2. When this LED is lit, it means power is present on the motherboard. Be sure to turn off the system and unplug the power cord(s) before removing or installing components.

Onboard Power LED Indicator	
LED Color	Definition
Off	System Off (power cable not connected)
Green	System On

### UID LED Indicator

The UID LED indicator is located at LED2, next to the UID button. When you press the UID button, the UID LED indicator will turn on. Press the UID button again to turn off the LED indicator. The LED indicator provides easy identification of a system unit that may need service.

UID LED Pin Definitions	
Color	Status
Blue: On	Unit Identified

### System Failure LED

LED3 is the System Failure LED. When this LED is solid red, it means a system overheat. When this LED is blinking red, it means a power failure or fan failure. Turn off the system and unplug the power cord before removing or installing components.

System Overheat/Power Failure/Fan Failure LED Indicator	
LED Color	Definition
Off	System Temperature, Power Supply, and Fan are healthy
Solid Red	System Overheat
Blinking Red	Power or Fan Failure

### BMC Heartbeat LED

A BMC Heartbeat LED is located at LED1. Refer to the table below for more information.

BMC Heartbeat LED Indicator	
LED Color	Definition
Blinking Green	BMC Normal

# Chapter 5

## Software

After the hardware has been installed, you can install the Operating System (OS), configure RAID settings and install the drivers.

### 5.1 Microsoft Windows OS Installation

If you will be using RAID, you must configure RAID settings before installing the Windows OS and the RAID driver. Refer to the RAID Configuration User Guides posted on our website at [www.supernmicro.com/support/manuals](http://www.supernmicro.com/support/manuals).

#### *Installing the OS*

1. Create a method to access the MS Windows installation ISO file. That might be a DVD, perhaps using an external USB/SATA DVD drive, or a USB flash drive, or the IPMI KVM console.
2. Retrieve the proper RST/RSTe driver. Go to the Supermicro web page for your motherboard and click on "Download the Latest Drivers and Utilities", select the proper driver, and copy it to a USB flash drive.
3. Boot from a bootable device with Windows OS installation. You can see a bootable device list by pressing **F11** during the system startup.

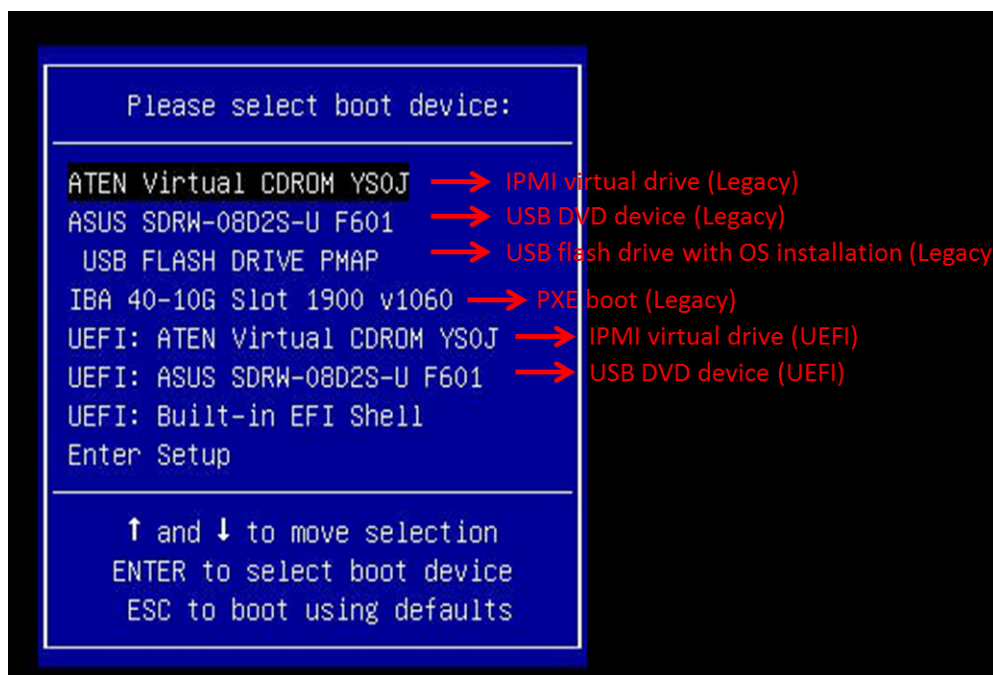
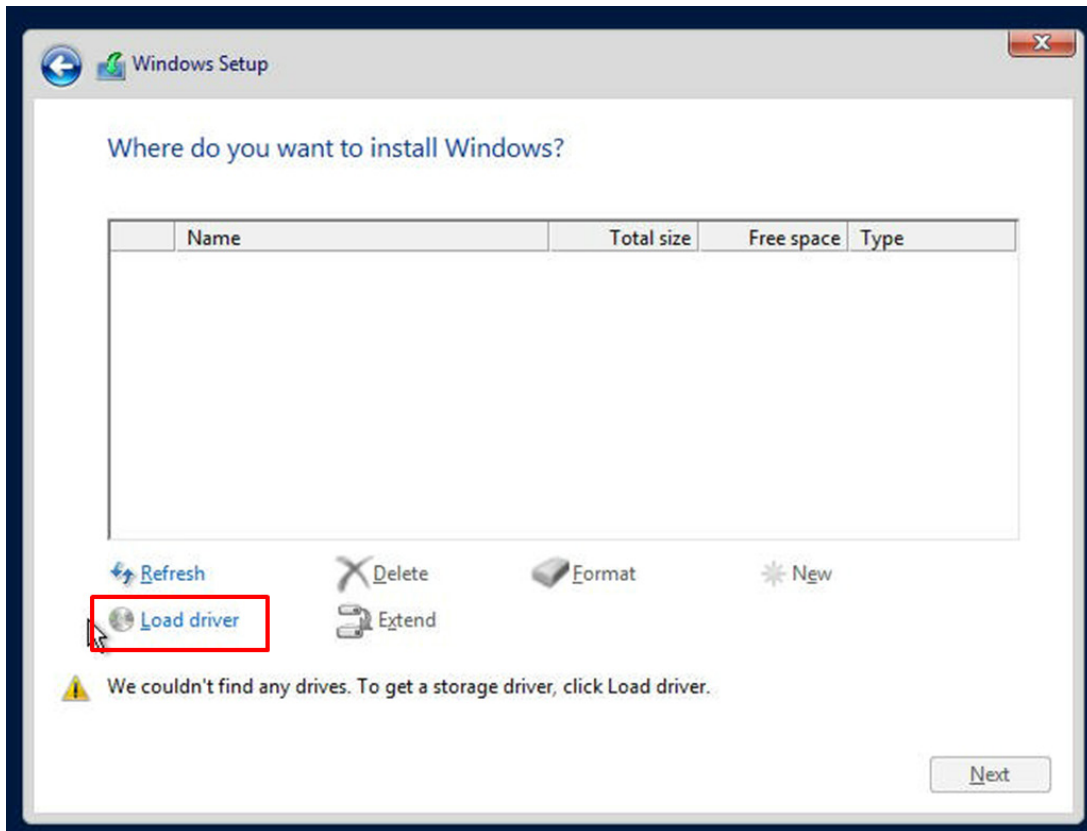

Figure 5-1. Select Boot Device

4. During Windows Setup, continue to the dialog where you select the drives on which to install Windows. If the disk you want to use is not listed, click on “Load driver” link at the bottom left corner.



**Figure 5-2. Load Driver Link**

To load the driver, browse the USB flash drive for the proper driver files.

- For RAID, choose the SATA/sSATA RAID driver indicated then choose the storage drive on which you want to install it.
  - For non-RAID, choose the SATA/sSATA AHCI driver indicated then choose the storage drive on which you want to install it.
5. Once all devices are specified, continue with the installation.
  6. After the Windows OS installation has completed, the system will automatically reboot multiple times.

## 5.2 Driver Installation

The Supermicro website contains drivers and utilities for your system at <https://www.supermicro.com/wftp/driver>. Some of these must be installed, such as the chipset driver.

After accessing the website, go into the CDR\_Images (in the parent directory of the above link) and locate the ISO file for your motherboard. Download this file to to a USB flash drive or a DVD. (You may also use a utility to extract the ISO file if preferred.)

Another option is to go to the Supermicro website at <http://www.supermicro.com/products/>. Find the product page for your motherboard, and "Download the Latest Drivers and Utilities".

Insert the flash drive or disk and the screenshot shown below should appear.

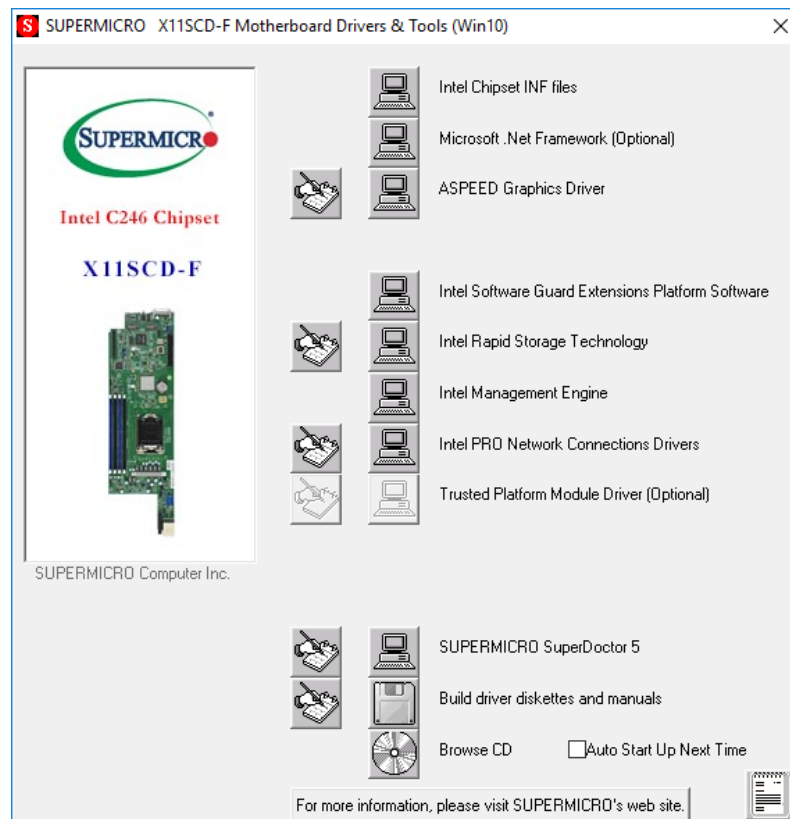

**Figure 5-3. Driver & Tool Installation Screen**

**Note:** Click the icons showing a hand writing on paper to view the readme files for each item. Click the computer icons to the right of these items to install each item (from top to the bottom) one at a time. **After installing each item, you must re-boot the system before moving on to the next item on the list.** The bottom icon with a CD on it allows you to view the entire contents.

## 5.3 SuperDoctor® 5

The Supermicro SuperDoctor 5 is a program that functions in a command-line or web-based interface for Windows and Linux operating systems. The program monitors such system health information as CPU temperature, system voltages, system power consumption, fan speed, and provides alerts via email or Simple Network Management Protocol (SNMP).

SuperDoctor 5 comes in local and remote management versions and can be used with Nagios to maximize your system monitoring needs. With SuperDoctor 5 Management Server (SSM Server), you can remotely control power on/off and reset chassis intrusion for multiple systems with SuperDoctor 5 or IPMI. SuperDoctor 5 Management Server monitors HTTP, FTP, and SMTP services to optimize the efficiency of your operation.

**Note:** The default User Name and Password for SuperDoctor 5 is ADMIN / ADMIN.

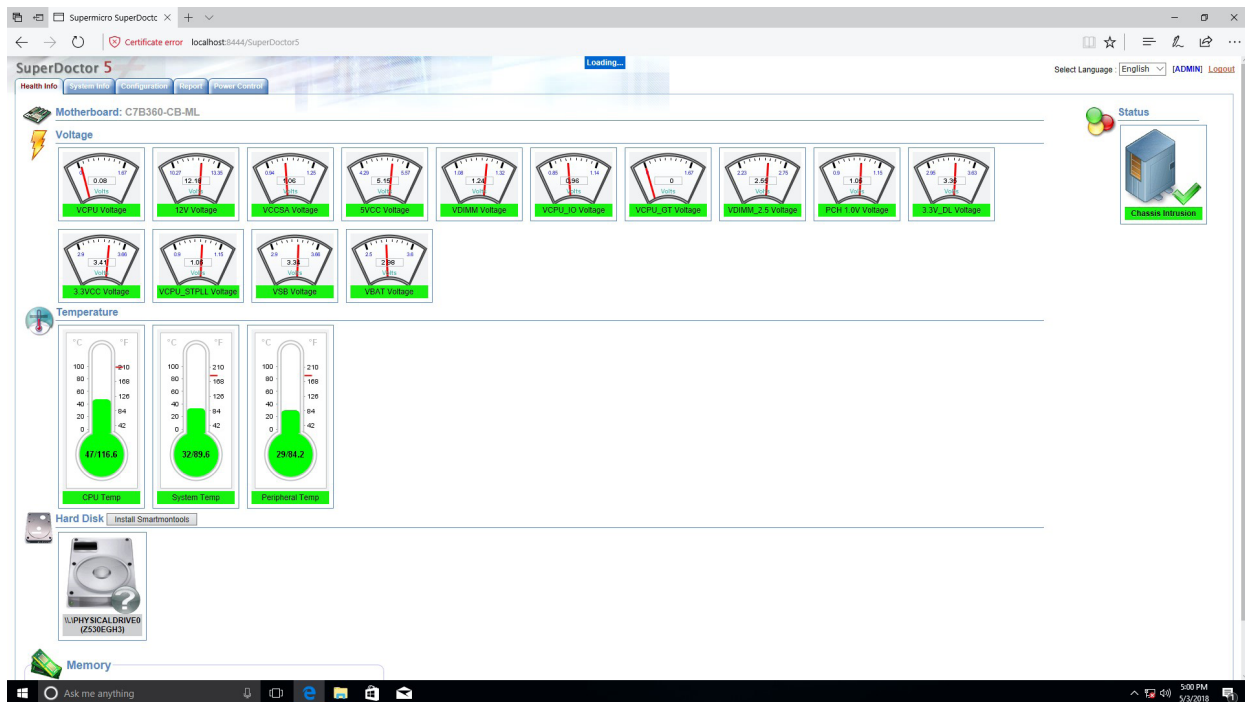

Figure 5-4. SuperDoctor 5 Interface Display Screen (Health Information)

## 5.4 IPMI

The X11SCD-F supports the Intelligent Platform Management Interface (IPMI). IPMI is used to provide remote access, monitoring and management. There are several BIOS settings that are related to IPMI.

IPMI management capabilities for all nodes are supported when one of two dedicated IPMI LAN ports are connected. Multi-node information and the system information can be displayed at the same time.

In IPMI Web GUI view, information can be displayed by clicking **Multi Node** under the **Server Health** drop-down menu. To access the other nodes within the same enclosure, click the IP address of the other nodes.

In IPMI CLI view, typing the command "SMCIPMITool -tp info", allows the MCU information of all eight nodes to be displayed.

For general documentation and information on IPMI, please visit our website at: <http://www.supermicro.com/products/nfo/IPMI.cfm>.

## Chapter 6

# UEFI BIOS

### 6.1 Introduction

This chapter describes the AMIBIOS™ Setup utility for the X11SCD-F motherboard and provides the instructions on navigating the setup screens. The BIOS is stored in a flash chip and can be easily upgraded using a flash program.

**Note:** Due to periodic changes to the BIOS, some settings may have been added or deleted since this manual was published.

#### Starting BIOS Setup Utility

To enter the AMI BIOS setup utility screens, press the <Delete> key while the system is booting up. (There are a few cases when other keys are used, such as <F1>, <F2>, etc.)

The BIOS screens have three main frames. The large left frame displays options can be configured by the user. These are blue. When an option is selected, it is highlighted in white. Settings printed in **Bold** are the default values.

In the left frame, a " ►" indicates a submenu. Highlighting such an item and pressing the <Enter> key opens the list of settings in that submenu.

The upper right frame displays helpful information for the user. The AMI BIOS has default informational messages built in. The manufacturer retains the option to include, omit, or change any of these informational messages.

The lower right frame lists navigational methods. The AMI BIOS setup utility uses a key-based navigation system called *hot keys*. Most of these hot keys can be used at any time during setup navigation. These keys include <F3>, <F4>, <Enter>, <ESC>, arrow keys, etc.

Some system parameters may be changed.

### 6.2 Main Setup

When running the AMI BIOS setup utility, it starts with the Main screen. You can always return to it by selecting the Main tab on the top of the screen.

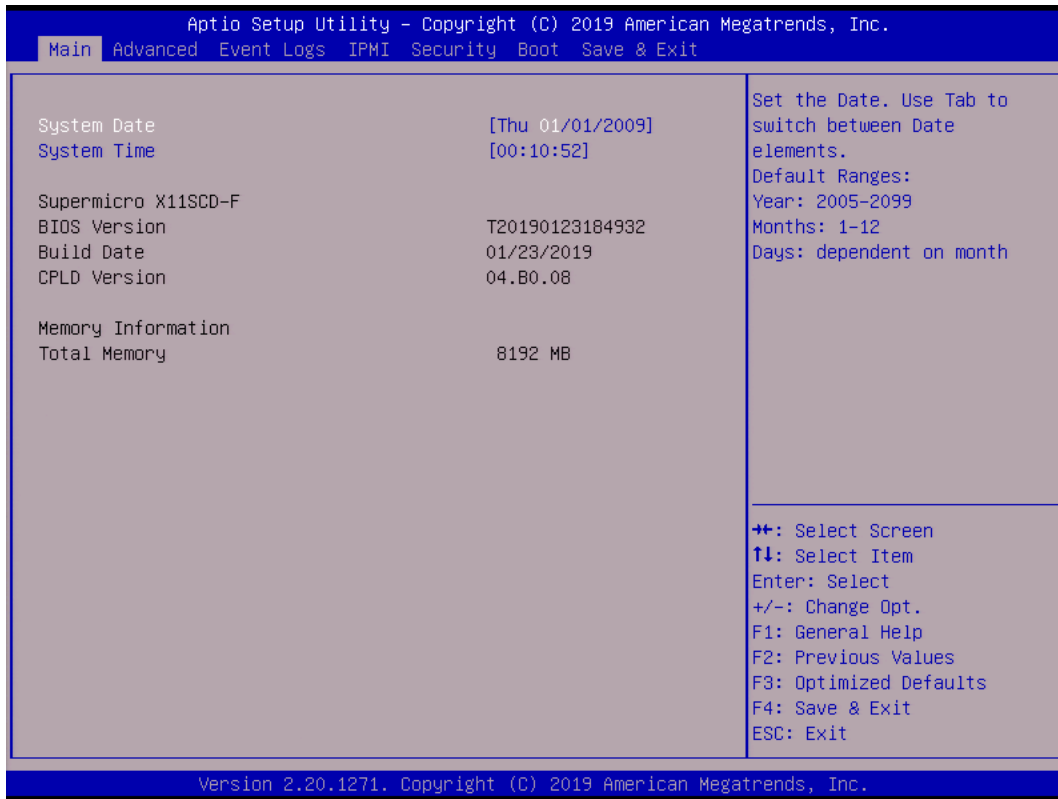

The Main tab page allows you to set the date and time, and it displays system information.

### System Date/System Time

Use this option to change the system date and time. Highlight *System Date* or *System Time* using the arrow keys. Enter new values using the keyboard. Press the <Tab> key or the arrow keys to move between fields. The date must be entered in MM/DD/YYYY format. The time is entered in HH:MM:SS format.

**Note:** The time is in the 24-hour format. For example, 5:30 P.M. appears as 17:30:00. The date's default value is 01/01/2016 after RTC reset.

### Supermicro X11SCD-F (Motherboard model)

#### BIOS Version

#### Build Date (of the BIOS)

**CPLD (Complex Programmable Logic Device) Version:** This item displays the CPLD version used in the system.

### Memory Information

#### Total Memory (for the system)

#### Memory Speed

## 6.3 Advanced Setup Configurations

Use the arrow keys to select the Advanced tab and press <Enter> to access the submenu items.

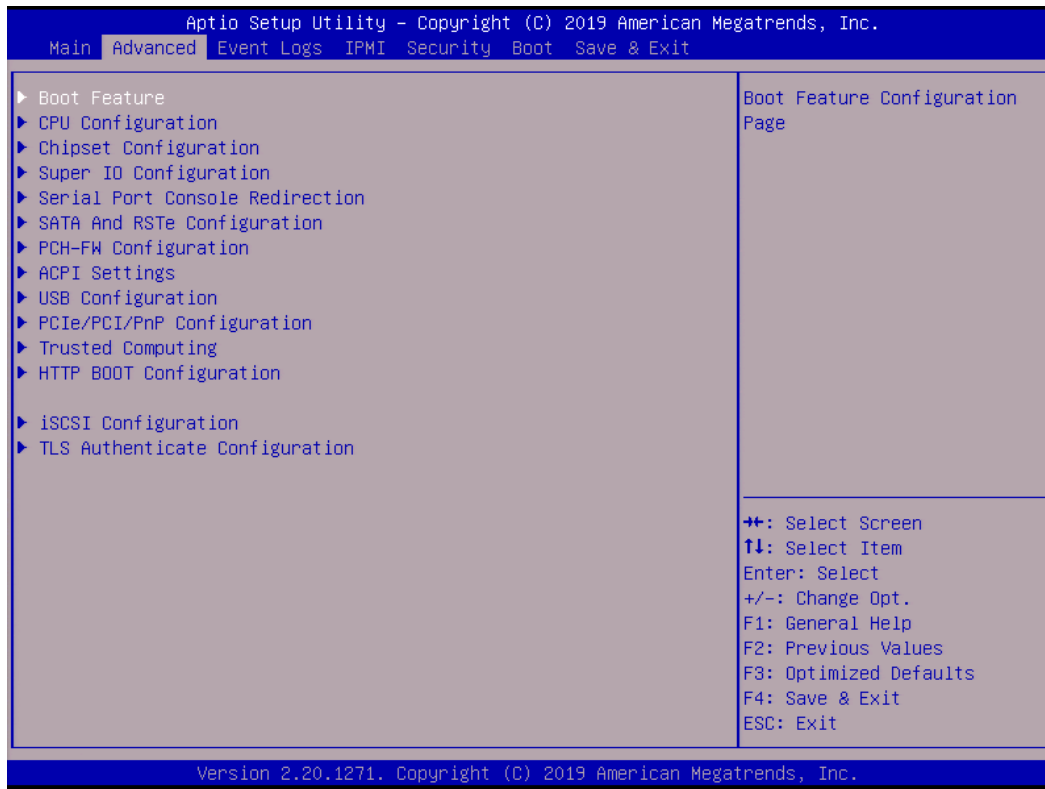

**Caution:** Take caution when changing the Advanced settings. An incorrect value, a very high DRAM frequency, or an incorrect DRAM timing setting may make the system unstable. If this occurs, revert to the manufacture default settings.

### ►Boot Feature

#### Fast Boot

Enable this feature to reduce the time the computer takes to boot up. The computer will boot with a minimal set of required devices. This feature does not have an effect on BBS boot options in the Boot tab. The options are **Disabled** and Enabled.

#### Quiet Boot

Use this feature to select the screen display between POST messages or the OEM logo at bootup. Select Disabled to display the POST messages. Select Enabled to display the OEM logo instead of the normal POST messages. The options are Disabled and **Enabled**.

#### Bootup NumLock State

Use this feature to set the Power-on state for the Numlock key. The options are Off and **On**.

**Option ROM Messages**

Use this feature to set the display mode for the Option ROM. Select Keep Current to display the current AddOn ROM setting. Select Force BIOS to use the Option ROM display set by the system BIOS. The options are **Force BIOS** and Keep Current.

**Bootup NumLock State**

Use this feature to set the Power-on state for the Numlock key. The options are **On** and Off.

**Wait For "F1" If Error**

This feature forces the system to wait until the F1 key is pressed if an error occurs. The options are Disabled and **Enabled**.

**Re-try Boot**

If this feature is enabled, the BIOS will automatically reboot the system from a specified boot device after its initial boot failure. The options are **Disabled**, Legacy Boot, and EFI Boot.

**Power Configuration****Watch Dog Function**

If enabled, the Watch Dog timer will allow the system to reboot when it is inactive for more than five minutes. The options are **Disabled** and Enabled.

**Restore on AC Power Loss**

Use this feature to set the power state after a power outage. Select Power Off for the system power to remain off after a power loss. Select Power On for the system power to be turned on after a power loss. Select Last State to allow the system to resume its last power state before a power loss. The options are Stay Off, Power On, and **Last State**.

**Power Button Function**

This feature controls how the system shuts down when the power button is pressed. Select 4 Seconds Override for the user to power off the system after pressing and holding the power button for four seconds or longer. Select Instant Off to instantly power off the system as soon as the user presses the power button. The options are **Instant Off** and 4 Seconds Override.

**DeepSx Power Policies**

Use this feature to configure the Advanced Configuration and Power Interface (ACPI) settings for the system. Enable S5 to power off the whole system except the power supply unit (PSU) and keep the power button alive so that the user can wake up the system by using a USB keyboard or mouse. The options are **Disabled** and Enabled in S4-S5.

## ► CPU Configuration

The following CPU information will display:

- Processor type
- CPU Signature
- Microcode Revision
- CPU Speed
- L1 Data Cache
- L1 Instruction Cache
- L2 Cache
- L3 Cache
- L4 Cache
- VMX
- SMX/TXT

### **CPU Flex Ration Override**

Select Enabled to activate CPU Flex Ration programming. The flex ratio should be under the CPU's max ration. The options are **Disabled** and Enabled.

***\*If the feature above is set to Enabled, "CPU Flex Ration Setting" will become available for configuration:***

### **CPU Flex Ratio Settings**

When CPU Flex Ration override is enabled, this feature sets the value for the CPU Flex Ration. The value must be between the maximum efficiency ratio and maximum non-turbo ratio. The default value is dependent on the CPU.

### **Hardware Prefetcher**

If set to Enable, the hardware prefetcher will prefetch streams of data and instructions from the main memory to the L2 cache to improve CPU performance. The options are Disabled and **Enabled**.Adjacent Cache Line Prefetch

**Adjacent Cache Line Prefetch**

The CPU prefetches the cache line for 64 bytes if this feature is set to Disabled. The CPU prefetches both cache lines for 128 bytes as comprised if this feature is set to Enabled. The options are Disabled and **Enabled**.

**Intel (VMX) Virtualization Technology**

Use this feature to enable the Vantderpool Technology. This technology allows the system to run several operating systems simultaneously. The options are Disabled and **Enabled**.

**Active Processor Cores**

This feature determines how many CPU cores will be activated for each CPU. When all is selected, all cores in the CPU will be activated. The options are **All** and 1, 2, 3, 4, and 5.

**BIST**

Use this feature to enable the Built-in Self Test (BIST) at system reset or reboot. The options are **Disabled** and Enabled.

**AES**

Select Enabled for Intel CPU Advanced Encryption Standard (AES) instructions support to enhance data integrity. The options are Disabled and **Enabled**.

**Boot Performance Mode**

This feature allows the user to select the performance state that the BIOS will set before the operating system handoff. The options are Power Saving, **Max Non-Turbo Performance**, and Turbo Performance.

**Intel® SpeedStep™**

Intel SpeedStep Technology allows the system to automatically adjust processor voltage and core frequency to reduce power consumption and heat dissipation. The options are **Disabled** and Enabled.

**Intel® Speed Shift Technology**

Use this feature to enable or disable Intel Speed Shift Technology support. When this feature is enabled, the Collaborative Processor Performance Control (CPPC) version 2 interface will be available to control CPU P-States. The options are **Disabled** and Enabled.

**Monitor/Wait**

Select Enable to enable the Monitor/Mwait instructions. The Monitor instructions monitors a region of memory for writes, and Mwait instructions instruct the CPU to stop until the monitored region begins to write. The options are Disabled and **Enabled**.C states

Use this feature to enable the C-State of the CPU. The options are Disabled and **Enabled**.

### **C States**

Use this feature to enable the C-State of the CPU. The options are Disabled and **Enabled**.

### **Enhanced C-states**

Use this feature to enable the enhanced C-State of the CPU. The options are Disabled and **Enabled**.

### **C-State Auto Demotion**

Use this feature to prevent unnecessary excursions into the C-states to improve latency. The options are Disabled, C1, C3, and **C1 and C3**.

### **C-State Un-demotion**

This feature allows the user to enable or disable the un-demotion of C-State. The options are Disabled, C1, C3, and **C1 and C3**.

### **Package C-State Demotion**

Use this feature to enable or disable the Package C-State demotion. The options are **Disabled** and Enabled.

### **Package C-State Un-demotion**

Use this feature to enable or disable the Package C-State un-demotion. The options are **Disabled** and Enabled.

### **CState Pre-Wake**

This feature allows the user to enable or disable the C-State Pre-Wake. The options are Disabled and **Enabled**.

### **Package C State Limit**

Use this feature to set the Package C-State limit. The options are C0/C1, C2, C3, C6, C7, C7s, C8, C9, C10, Cpu Default, and **Auto**.

### **Power Limit 1 Override**

Select Enabled to support average power limit (PL1) override. The default setting is **Disabled**.

### **Power Limit 2 Override**

Select Enabled to support rapid power limit (PL2) override. The default setting is **Enabled**.

### **Power Limit 2**

Use this item to configure the value for Power Limit 2. The value is in milliwatts and the step size is 125mW. Use the number keys on your keyboard to enter the value. Enter 0 to use the manufacture default setting. If the value is 0, the BIOS will set PL2 as 1.25\* TDP.

### ACPI T-States

Use this feature to select Enabled to support CPU throttling by the operating system to reduce power consumption. The options are **Disabled** and Enabled.

## ► Chipset Configuration

**Warning:** Setting the wrong values in the sections below may cause the system to malfunction.

### ► System Agent (SA) Configuration

The following information will display:

- SA PCIe Code Version
- VT-d: Supported

### ► Memory Configuration

#### Memory Configuration

- Memory RC Version
- Memory Frequency
- Memory Timings (tCL-tRCD-tRP-tRAS)
- DIMMA1
- DIMMA2
- DIMMB1
- DIMMB2

#### Maximum Memory Frequency

Use this feature to set the maximum memory frequency for onboard memory modules. The options are **Auto**, 1067, 1200, 1333, 1400, 1600, 1800, 1867, 2000, 2133, 2200, 2400, 2600, and 2667.

#### Max TOLUD

This feature sets the maximum TOLUD value, which specifies the "Top of Low Usable DRAM" memory space to be used by internal graphics devices, GTT Stolen Memory, and TSEG, respectively, if these devices are enabled. The options are **Dynamic**, 1 GB, 1.25 GB, 1.5 GB, 1.75 GB, 2 GB, 2.25 GB, 2.5 GB, 2.75 GB, 3 GB, 3.25 GB, and 3.5 GB.

### **Memory Scrambler**

Use this feature to enable or disable memory scrambler support. The options are Disabled and **Enabled**.

### **Fast Boot**

Use this feature to enable or disable fast path through the memory reference code. The options are Disabled and **Enabled**.

### **REFRESH\_2X\_MODE**

Use this feature to select the refresh mode. The options are **Disabled**, 1-Enabled for WARM or HOT, and 2-Enabled HOT only.

## **► DMI/OPI Configuration**

The following DMI information will display:

### **DMI X4 Gen3**

#### **DMI Link ASPM Control**

Use this feature to set the ASPM (Active State Power Management) state on the SA (System Agent) side of the DMI Link. The options are Disabled, L0s, **L1**, and L0sL1.

#### **DMI Extended Sync Control**

Use this feature to enable or disable the DMI extended synchronization. The options are Enabled and **Disabled**.

#### **DMI De-emphasis Control**

Use this feature to configure the De-emphasis control on DMI. The options are -6 dB and **-3.5 dB**.

## **► PEG Port Configuration**

### **CPU MICRO-LP PCIE 3.0 X8**

#### **Enable Root Port**

Use this feature to enable or disable the PCI Express Graphics (PEG) device in the port specified by the user. The options are Disabled, Enabled, and **Auto**.

#### **Max Link Speed**

Use this feature to select the speed for the device installed in the specified port. The options are **Auto**, Gen 1, Gen 2, and Gen 3.

**Power Limit Value**

Use this feature to set the upper limit on the power supplied by the PCIE slot. Press "+" or "-" on your keyboard to change this value. The default setting is **75**.

**Power Limit Scale**

Use this feature to select the scale used for the slot power limit value. The options are **1.0x**, 0.1x, 0.01x, 0.001x.

**Physical Slot Number**

Use this feature to set the physical slot number attached to this port. The values are 0-8191. The default value is 1.

**Max Payload Size**

Use this feature to select the PEG0 maximum payload size. The options are **Auto**, 128, 256 TLP.

**CPU SLOT1 PCIE 3.0 X8****Enable Root Port**

Use this feature to enable or disable the PCI Express Graphics (PEG) device in the port specified by the user. The options are Disabled, Enabled, and **Auto**.

**Max Link Speed**

Use this feature to select speed for the device installed in the specified port. The options are **Auto**, Gen 1, Gen 2, and Gen 3.

**Max Link Width**

Use this feature to enable the PCI-E ASPM L0S. The options are **Auto**, Force X1, Force X2, and Force X4.

**ASPM (Available if graphics card is detected)**

Use this feature to activate the Active State Power Management (ASPM) level for a PCI-E device. Select Auto for the system BIOS to automatically set the ASPM level based on the system configuration. Select Disabled to disable ASPM support. The options are **Disabled**, Auto, ASPM L0s, ASPM L1, ASPM L0sL1.

**De-emphasis Control**

Use this feature to configure the De-emphasis control on PEG. The options are -6 dB and **-3.5dB**.

### Power Limit Value

Use this feature to set the upper limit on the power supplied by the PCIE slot. Press "+" or "-" on your keyboard to change this value. The default setting is **75**. Power Limit Scale

Use this feature to select the scale used for the slot power limit value. The options are **1.0x**, 0.1x, 0.01x, 0.001x.

### Physical Slot Number

Use this feature to set the physical slot number attached to this port. The values are 0-8191. The default value is 2.

### Max Payload Size

Use this feature to select the PEG0 maximum payload size. The options are **Auto**, 128, 256 TLP.

### Program PCIe ASPM After OpROM

PCIe ASPM, the Active State Power Management for PCI-Express slots, is a power management protocol used to manage power consumption of serial link devices installed on PCI-E slots during a prolonged off-peak time. If this feature is set to Enabled, PCI-E ASPM will be programmed after OPROM. If set to Disabled, the PCI-E ASPM will be programmed before OPROM. The options are **Disabled** and Enabled.

### Internal Graphics

Select Auto to keep an internal graphics device installed on an expansion slot supported by the CPU to be automatically enabled. The options are Auto, **Disabled**, and Enabled.

### VT-d

Select Enabled to activate Intel Virtualization Technology support for Direct I/O VT-d by reporting the I/O device assignments to VMM through the DMAR ACPI Tables. This feature offers fully-protected I/O resource-sharing across the Intel platforms, providing the user with greater reliability, security and availability in networking and data-sharing. The options are Disabled and **Enabled**.

### GNA Device (B0:D8:F0)

Use this feature to enable SA GNA device. The options are **Enabled** and Disabled.

### X2APIC Opt Out

The feature "VT-D" must be enabled for this feature to be configurable. Use this feature to enable or disable X2APIC Opt Out. The options are Enabled and **Disabled**. ▶ PCH-IO Configuration

## ► PCH-IO Configuration

### ► PCI Express Configuration

#### **DMI Link ASPM Control**

Use this feature to set the ASPM (Active State Power Management) state on the SA (System Agent) side of the DMI Link. The options are Disabled, L0s, L1, L0sL1, and **Auto**.

#### **Peer Memory Write Enable**

Use this feature to enable or disable peer memory write. The options are **Disabled** and Enabled.

### ► JMD1:M.2-H

#### **JMD1:M.2-H ASPM Support**

Use this feature to activate the Active State Power Management (ASPM) level for a PCI-E device. Select Auto for the system BIOS to automatically set the ASPM level based on the system configuration. Select Disabled to disable ASPM support. The options are Disabled, L0s, L1, L0sL1, and **Auto**.

#### **JMD1:M.2-H L1 Substates**

Use this feature to set the PCI Express L1 Substates. The options are Disabled, L1.1, and **L1.1 & L1.2**.

#### **JMD1:M.2-H PCIe Speed**

Use this feature to select the PCI Express port speed. The options are **Auto**, Gen1, Gen2, and Gen3.

### ► JMD2:M.2-H

#### **JMD2:M.2-H ASPM Support**

Use this feature to activate the Active State Power Management (ASPM) level for a PCI-E device. Select Auto for the system BIOS to automatically set the ASPM level based on the system configuration. Select Disabled to disable ASPM support. The options are Disabled, L0s, L1, L0sL1, and **Auto**.

#### **JMD2:M.2-H L1 Substates**

Use this feature to set the PCI Express L1 Substates. The options are Disabled, L1.1, and **L1.1 & L1.2**.

### **JMD2:M.2-H PCIe Speed**

Use this feature to select the PCI Express port speed. The options are **Auto**, Gen1, Gen2, and Gen3.

### **Port 61h Bit-4 Emulation**

Select Enabled to enable the emulation of Port 61h bit-4 toggling in SMM (System Management Mode). The options are Disabled and **Enabled**.

### **PCIe PLL SSC**

Use this feature to enable or disable PCIe PLL SSC. The options are **Enabled** and Disabled.

## **► Super IO Configuration**

### **Super IO Chip AST2500**

#### **► Serial Port 1 Configuration**

##### **Serial Port**

Select Enabled to enable the selected onboard serial port. The options are Disabled and **Enabled**.

##### **Device Settings**

This feature displays the status of a serial port specified by the user.

##### **Change Settings**

This feature specifies the base I/O port address and the Interrupt Request address of a serial port specified by the user. Select Auto to allow the BIOS to automatically assign the base I/O and IRQ address. The options are **Auto**, (IO=3F8h; IRQ=4;), (IO=2F8h; IRQ=4;), (IO=3E8h; IRQ=4;), and (IO=2E8h; IRQ=4;).

#### **► Serial Port 2 Configuration**

##### **Serial Port**

Select Enabled to enable the selected onboard serial port. The options are Disabled and **Enabled**.

##### **Device Settings**

This feature displays the status of a serial port specified by the user.

### Change Settings

This feature specifies the base I/O port address and the Interrupt Request address of a serial port specified by the user. Select Auto to allow the BIOS to automatically assign the base I/O and IRQ address. The options are **Auto**, (IO=3F8h; IRQ=3;), (IO=2F8h; IRQ=3;), (IO=3E8h; IRQ=3;), and (IO=2E8h; IRQ=3;).

## ►Serial Port Console Redirection

### COM1

#### Console Redirection

Select Enabled to enable COM1 for Console Redirection, which will allow a client machine to be connected to a host machine at a remote site for networking. The options are **Disabled** and Enabled.

***\*If the feature above is set to Enabled, the following features will become available for configuration:***

### ►Console Redirection Settings

#### Terminal Type

This feature allows the user to select the target terminal emulation type for Console Redirection. Select VT100 to use the ASCII Character set. Select VT100+ to add color and function key support. Select ANSI to use the Extended ASCII Character Set. Select VT-UTF8 to use UTF8 encoding to map Unicode characters into one or more bytes. The options are VT100, **VT100+**, VT-UTF8, and ANSI.

#### Bits per second

Use this feature to set the transmission speed for a serial port used in Console Redirection. Make sure that the same speed is used in the host computer and the client computer. A lower transmission speed may be required for long and busy lines. The options are 9600, 19200, 38400, 57600, and **115200** (bits per second).

#### Data Bits

Use this feature to set the data transmission size for Console Redirection. The options are 7 (Bits) and **8 (Bits)**.

### **Parity**

A parity bit can be sent along with regular data bits to detect data transmission errors. Select Even if the parity bit is set to 0, and the number of 1's in data bits is even. Select Odd if the parity bit is set to 0, and the number of 1's in data bits is odd. Select None if you do not want to send a parity bit with your data bits in transmission. Select Mark to add a mark as a parity bit to be sent along with the data bits. Select Space to add a Space as a parity bit to be sent with your data bits. The options are **None**, Even, Odd, Mark, and Space.

### **Stop Bits**

A stop bit indicates the end of a serial data packet. Select 1 Stop Bit for standard serial data communication. Select 2 Stop Bits if slower devices are used. The options are **1** and **2**.

### **Flow Control**

Use this feature to set the flow control for Console Redirection to prevent data loss caused by buffer overflow. Send a "Stop" signal to stop sending data when the receiving buffer is full. Send a "Start" signal to start sending data when the receiving buffer is empty. The options are **None** and Hardware RTS/CTS.

### **VT-UTF8 Combo Key Support**

Select Enabled to enable VT-UTF8 Combination Key support for ANSI/VT100 terminals. The options are Disabled and **Enabled**.

### **Recorder Mode**

Select Enabled to capture the data displayed on a terminal and send it as text messages to a remote server. The options are **Disabled** and Enabled.

### **Resolution 100x31**

Select Enabled for extended-terminal resolution support. The options are Disabled and **Enabled**.

### **Putty KeyPad**

This feature selects Function Keys and KeyPad settings for Putty, which is a terminal emulator designed for the Windows OS. The options are **VT100**, LINUX, XTERMR6, SCO, ESCN, and VT400.

## **Legacy Console Redirection**

### **► Legacy Console Redirection Settings**

#### **Redirection COM Port**

Use this feature to select a COM port to display redirection of Legacy OS and Legacy OPROM messages. The options are **COM1** and SOL.

### **Legacy OS Redirection Resolution**

Use this feature to select the number of rows and columns used in Console Redirection for legacy OS support. The options are 80x24 and **80x25**.

### **Redirection After BIOS POST**

Use this feature to enable or disable legacy console redirection after BIOS POST. When set to BootLoader, legacy console redirection is disabled before booting the OS. When set to Always Enable, legacy console redirection remains enabled when booting the OS. The options are **Always Enable** and BootLoader.

## **Serial Port for Out-of-Band Management/Windows Emergency Management Services (EMS)**

### **Console Redirection**

Select Enabled to use a COM port selected by the user for EMS Console Redirection. The options are **Disabled** and Enabled.

***\*If the feature above is set to Enabled, the following features are available for configuration:***

### **► Console Redirection Settings**

#### **Out-of-Band Mgmt Port**

The feature selects a serial port in a client server to be used by the Microsoft Windows Emergency Management Services (EMS) to communicate with a remote host server. The options are **COM1** and SOL.

#### **Terminal Type**

Use this feature to select the target terminal emulation type for Console Redirection. Select VT100 to use the ASCII character set. Select VT100+ to add color and function key support. Select ANSI to use the extended ASCII character set. Select VT-UTF8 to use UTF8 encoding to map Unicode characters into one or more bytes. The options are VT100, VT100+, **VT-UTF8**, and ANSI.

#### **Bits per second**

This feature sets the transmission speed for a serial port used in Console Redirection. Make sure that the same speed is used in the host computer and the client computer. A lower transmission speed may be required for long and busy lines. The options are 9600, 19200, 57600, and **115200** (bits per second).

### **Flow Control**

Use this feature to set the flow control for Console Redirection to prevent data loss caused by buffer overflow. Send a "Stop" signal to stop sending data when the receiving buffer is full. Send a "Start" signal to start sending data when the receiving buffer is empty. The options are **None**, Hardware RTS/CTS, and Software Xon/Xoff.

### **Data Bits**

### **Parity**

### **Stop Bits**

## **► SATA and RSTe Configuration**

### **SATA Controller(s)**

This feature enables or disables the onboard SATA controller supported by the Intel PCH chip. The options are **Enabled** and Disabled.

### **SATA Mode Selection**

Select AHCI to configure a SATA drive specified by the user as an AHCI drive. Select RAID to configure a SATA drive specified by the user as a RAID drive. The options are **AHCI** and RAID.

### **SATA Frozen**

Use this feature to enable the HDD Security Frozen Mode. The options are Enabled and **Disabled**.

### **Aggressive LPM Support**

When this feature is enabled, the SATA AHCI controller manages the power usage of the SATA link. The controller will put the link in a low power mode during extended periods of I/O inactivity, and will return the link to an active state when I/O activity resumes. The options are **Disabled** and Enabled.

### **Storage Option ROM/UEFI Driver**

Select UEFI to load the EFI driver for system boot. Select Legacy to load a legacy driver for system boot. The options are Do not Launch, EFI, and **Legacy**.

### **Serial ATA Port 0 (SATA disk1)**

This feature displays the information detected on the installed SATA drive on the particular SATA port on the backplane.

- Model number of drive and capacity
- Software Preserve Support

**Serial ATA Port 0 Hot Plug**

Set this feature to Enable for hot plug support, which will allow the user to replace a SATA drive without shutting down the system. The options are Disabled and **Enabled**.

**Serial ATA Port 0 Spin Up Device**

Set this feature to enable or disable the PCH to initialize the device. The options are **Disabled** and Enabled.

**Serial ATA Port 0 SATA Device Type**

Use this feature to specify if the SATA port specified by the user should be connected to a Solid State Drive or a Hard Disk Drive. The options are **Hard Disk Drive** and Solid State Drive.

**Serial ATA Port 1 (JMD1)**

This feature displays the information detected on the installed SATA drive on the particular SATA port on the JMD1 slot.

- Model number of drive and capacity
- Software Preserve Support

**Serial ATA Port 1 Hot Plug**

Set this feature to Enable for hot plug support, which will allow the user to replace a SATA drive without shutting down the system. The options are Disabled and **Enabled**.

**Serial ATA Port 1 Spin Up Device**

Set this feature to enable or disable the PCH to initialize the device. The options are **Disabled** and Enabled.

**Serial ATA Port 1 SATA Device Type**

Use this feature to specify if the SATA port specified by the user should be connected to a Solid State Drive or a Hard Disk Drive. The options are **Hard Disk Drive** and Solid State Drive.

**Serial ATA Port 2 (SATA disk2)**

This feature displays the information detected on the installed SATA drive on the particular SATA port on the backplane.

- Model number of drive and capacity
- Software Preserve Support

### **Serial ATA Port 2 Hot Plug**

Set this feature to Enable for hot plug support, which will allow the user to replace a SATA drive without shutting down the system. The options are Disabled and **Enabled**.

### **Serial ATA Port 2 Spin Up Device**

Set this feature to enable or disable the PCH to initialize the device. The options are **Disabled** and Enabled.

### **Serial ATA Port 2 SATA Device Type**

Use this feature to specify if the SATA port specified by the user should be connected to a Solid State Drive or a Hard Disk Drive. The options are **Hard Disk Drive** and Solid State Drive.

### **Serial ATA Port 4 (JMD2)**

This feature displays the information detected on the installed SATA drive on the particular SATA port on the JMD2 slot.

- Model number of drive and capacity
- Software Preserve Support

### **Serial ATA Port 4 Hot Plug**

Set this feature to Enable for hot plug support, which will allow the user to replace a SATA drive without shutting down the system. The options are Disabled and **Enabled**.

### **Serial ATA Port 4 Spin Up Device**

Set this feature to enable or disable the PCH to initialize the device. The options are **Disabled** and Enabled.

### **Serial ATA Port 4 SATA Device Type**

Use this feature to specify if the SATA port specified by the user should be connected to a Solid State Drive or a Hard Disk Drive. The options are **Hard Disk Drive** and Solid State Drive.

## **► PCH-FW Configuration**

- Operational Firmware Version
- Backup Firmware Version
- Recovery Firmware Version
- ME Firmware Features

- ME Firmware Status #1
- ME Firmware Status #2
- Current State
- Error Code

## ►ACPI Settings

### **WHEA Support**

Select Enabled to support the Windows Hardware Error Architecture (WHEA) platform and provide a common infrastructure for the system to handle hardware errors within the Windows OS environment in order to reduce system crashes and enhance system recovery and health monitoring. The options are Disabled and **Enabled**.

### **High Precision Event Timer**

Select Enabled to activate the High Precision Event Timer (HPET) that produces periodic interrupts at a much higher frequency than a Real-time Clock (RTC) does in synchronizing multimedia streams, providing smooth playback and reducing the dependency on other timestamp calculation devices, such as an x86 RDTSC Instruction embedded in the CPU. The High Performance Event Timer is used to replace the 8254 Programmable Interval Timer. The options are Disabled and **Enabled**.

### **Native PCIE Enable**

Enable this feature to grant control of PCI Express Native hot plug, PCI Express Power Management Events, and PCI Express Capability Structure Control. The options are Disabled and **Enabled**.

### **Native ASPM**

Select Enabled for the operating system to control the ASPM, or Disabled for the BIOS to control the ASPM. The options are **Auto**, Enabled, and Disabled.

## ►USB Configuration

### USB Configuration

**USB Module Version: 21**

**USB Controllers: 1 XHCI**

**USB Devices: 2 Keyboards, 1 Mouse, 1 Hub**

### Legacy USB Support

Select Enabled to support onboard legacy USB devices. Select Auto to disable legacy support if there are no legacy USB devices present. Select Disabled to have all USB devices available for EFI applications only. The options are **Enabled**, Disabled, and Auto.

### XHCI Hand-off

This is a work-around solution for operating systems that do not support XHCI (Extensible Host Controller Interface) hand-off. The XHCI ownership change should be claimed by the XHCI driver. The settings are **Enabled** and Disabled.

### USB Mass Storage Driver Support

Select Enabled for USB mass storage device support. The options are Disabled and **Enabled**.

### Port 60/64 Emulation

Select Enabled for I/O port 60h/64h emulation support, which in turn, will provide complete legacy USB keyboard support for the operating systems that do not support legacy USB devices. The options are Disabled and **Enabled**.

## ►PCIe/PCI/PnP Configuration

### Option ROM execution

#### Onboard Video Option ROM

Use this feature to select the execution of the video OpROM. The options are **Legacy**, EFI, and Disabled.

#### PCI PERR/SERR Support

Use this feature to enable or disable the runtime event for PCI errors. The options are **Disabled** and Enabled.

### **Above 4G MMIO BIOS Assignment**

Select Enabled to decode a PCI device that supports 64-bit in the space above 4G Address. The options are Enabled and **Disabled**.

### **VGA Priority**

Use this feature to select VGA priority when multiple VGA devices are detected. Select Onboard to give priority to your onboard video device. Select Offboard to give priority to your graphics card. The options are **Onboard** and Offboard.

### **NVMe Firmware Source**

Use this feature to select the NVMe firmware to support booting. The options are **Vendor Defined Firmware** and AMI Native Support. The default option, Vendor Defined Firmware, is pre-installed on the drive and may resolve errata or enable innovative functions for the drive. The other option, AMI Native Support, is offered by the BIOS with a generic method.

### **PCIe/PCI/PnP Configuration**

#### **CPU MICRO-LP PCIE 3.0 X8 OPROM**

Use this feature to select which firmware to be loaded for the add-on card in this slot. The options are Disabled, **Legacy**, and EFI.

#### **CPU SLOT1 PCIE 3.0 X8 OPROM**

Use this feature to select which firmware to be loaded for the add-on card in this slot. The options are Disabled, **Legacy**, and EFI.

#### **JMD1:M.2-H OPROM/JMD2:M.2-H OPROM**

Use this feature to select which firmware to be loaded for the add-on card in this slot. The options are Disabled, **Legacy**, and EFI.

### **Network Stack**

Select Enabled to enable PXE (Preboot Execution Environment) or UEFI (Unified Extensible Firmware Interface) for network stack support. The options are Disabled and **Enabled**.

***\*If the feature above is set to Enabled, the features below will be available for configuration:***

#### **Ipv4 PXE Support**

Select Enabled to enable IPv4 PXE boot support. The options are Disabled and **Enabled**.

#### **Ipv4 HTTP Support**

Select Enabled to enable IPv4 HTTP boot support. The options are **Disabled** and Enabled.

#### **Ipv6 PXE Support**

Select Enabled to enable IPv6 PXE boot support. The options are Disabled and **Enabled**.

### **Ipv6 HTTP Support**

Select Enabled to enable IPv6 HTTP boot support. The options are **Disabled** and Enabled.

### **IPSEC Certificate**

The feature appears if Network Stack is enabled. Internet Protocol Security (IPSEC) offers a secure connection for remote computers using a secure tunnel. The options are **Disabled** and Enabled.

### **PXE boot wait time**

Use this feature to specify the wait time to press the ESC key to abort the PXE boot. Press "+" or "-" on your keyboard to change the value. The default setting is **0**.

### **Media detect count**

Use this option to specify the number of times media will be checked. Press "+" or "-" on your keyboard to change the value. The default setting is **1**.

## **►Trusted Computing**

***\*The features in the Trusted Computing section on this page are displayed if a TPM 1.2 module is detected:***

- Firmware Version
- Vendor

### **Security Device Support**

If this feature and the TPM jumper on the motherboard are both set to Enabled, onboard security devices will be enabled for TPM support to enhance data integrity and network security. Please reboot the system for a change on this setting to take effect. The options are Disable and **Enable**.

- Active PCR Banks
- Available PCR Banks

***\*If the feature "Security Device Support" is enabled, the following features are available for configuration:***

### **SHA-1 PCR Bank**

Use this feature to disable or enable the SHA-1 Platform Configuration Register (PCR) bank for the installed TPM device. The options are Disabled and **Enabled**.

**SHA256 PCR Bank**

Use this feature to disable or enable the SHA256 Platform Configuration Register (PCR) bank for the installed TPM device. The options are Disabled and **Enabled**.

**Pending operation**

Use this feature to schedule a TPM-related operation to be performed by a security device for system data integrity. Your system will reboot to carry out a pending TPM operation. The options are **None** and TPM Clear.

**Platform Hierarchy**

Use this feature to disable or enable platform hierarchy for platform protection. The options are Disabled and **Enabled**.

**Storage Hierarchy**

Use this feature to disable or enable storage hierarchy for cryptographic protection. The options are Disabled and **Enabled**.

**Endorsement Hierarchy**

Use this feature to disable or enable endorsement hierarchy for privacy control. The options are Disabled and **Enabled**.

**TPM2.0 UEFI Spec Version**

Use this feature to specify the TPM UEFI spec version. TCG 1.2 has support for Windows® 2012, Windows 8, and Windows 10. TCG 2 has support for Windows 10 or later. The options are TCG\_1\_2 and **TCG\_2**. Physical Presence Spec Version

Use this feature to select the PPI spec version. The options are 1.2 and **1.3**.

**Physical Presence Spec Version**

Use this feature to select the PPI spec version. The options are 1.2 and **1.3**.

**PH Randomization**

Use this feature to disable or enable Platform Hierarchy (PH) Randomization. The options are Disabled and **Enabled**.

**Device Select**

Use this feature to select the TPM version. TPM 1.2 will restrict support to TPM 1.2 devices. TPM 2.0 will restrict support for TPM 2.0 devices. Select Auto to enable support for both versions. The options are TPM 1.2, TPM 2.0, **Auto**.

**SMCI BIOS-Based TPM Provision Support**

Use this feature to enable the Supermicro TPM Provision support. The options are Disabled and **Enabled**.

## ▶ HTTP BOOT Configuration

### HTTP BOOT Configuration

#### Http Boot One Time

Use this feature to create the HTTP boot option. The options are **Disabled** and **Enable**.

#### Input the description

Highlight the feature and press enter to create a description.

#### Boot URI

Highlight the feature and press enter to create a boot URI.

## ▶ iSCSI Configuration

### iSCSI Initiator Name

This feature allows the user to enter the unique name of the iSCSI Initiator in IQN format. Once the name of the iSCSI Initiator is entered into the system, configure the proper settings for the following items.

#### ▶ Add an Attempt

#### ▶ Delete Attempts

#### ▶ Change Attempt Order ▶ TLS Authentication Configuration

This submenu allows the user to configure Transport Layer Security (TLS) settings.

## ▶ TLS Authentication Configuration

This submenu allows the user to configure Transport Layer Security (TLS) settings.

#### ▶ Server CA Configuration

#### ▶ Enroll Certification

##### Enroll Certification Using File

Use this feature to enroll certification from a file.

**Certification GUID**

Use this feature to input the certification GUID.

**Commit Changes and Exit**

Use this feature to save all changes and exit TLS settings.

**Discard Changes and Exit**

Use this feature to discard all changes and exit TLS settings.

**► Delete Certification**

Use this feature to delete certification.

## 6.4 IPMI

Use this tab page to configure Intelligent Platform Management Interface (IPMI) settings.

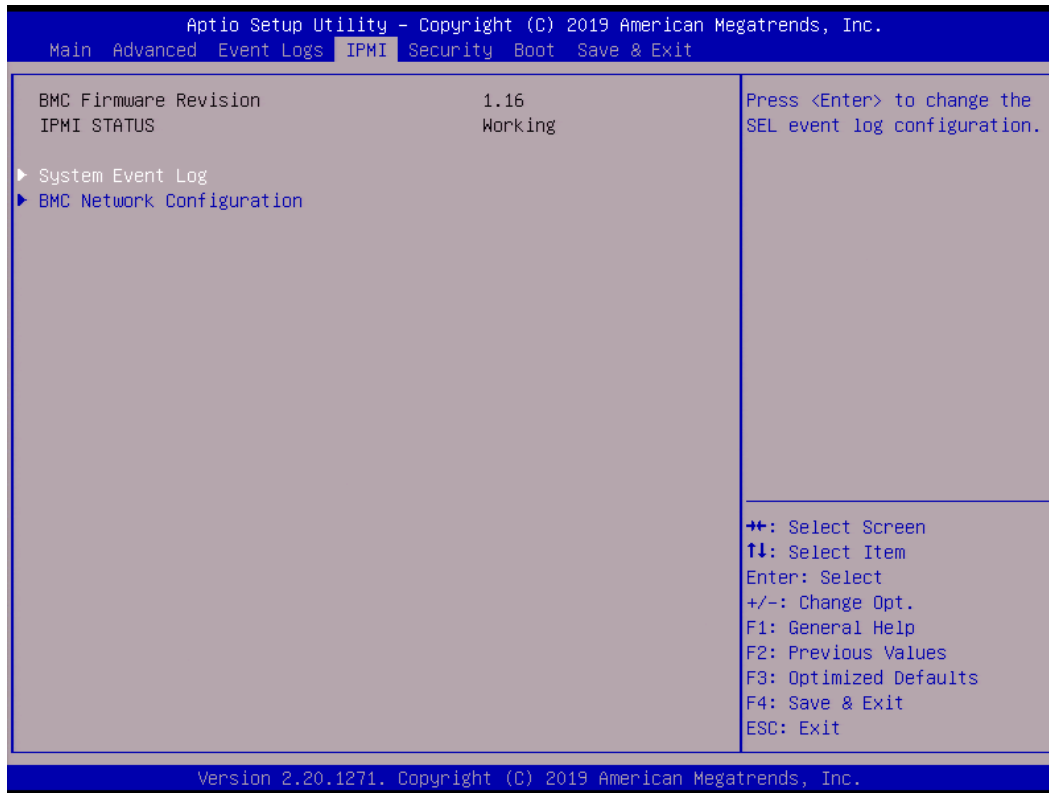

The following items will be displayed:

- IPMI Firmware Revision
- Status of BMC

### ► System Event Log

#### Enabling/Disabling Options

##### SEL Components

Select Enabled for all system event logging at boot up. The options are Disabled and Enabled.

##### Erasing Settings

##### Erase SEL

Select Yes, On next reset to erase all system event logs upon next system reboot. Select Yes, On every reset to erase all system event logs upon each system reboot. Select No to keep all system event logs after each system reboot. The options are **No**, Yes, On next reset, and Yes, On every reset.

### When SEL is Full

This feature allows the user to determine what the BIOS should do when the system event log is full. Select Erase Immediately to erase all events in the log when the system event log is full. The options are **Do Nothing** and Erase Immediately.

**Note:** After making changes on a setting, reboot the system for the changes to take effect.

## ► BMC Network Configuration

### BMC network configuration

#### Update IPMI LAN Configuration

Select Yes for the BIOS to implement all IP/MAC address changes at the next system boot. The options are **No** and Yes.

***\*If the feature above is set to Yes, the Configuration Address Source and VLAN features are available for configuration:***

#### Configure IPV4 support

#### IPMI LAN Selection

This feature displays the IPMI LAN setting. The default setting is **Failover**.

#### IPMI Network Link Status

This feature displays the IPMI Network Link status. The default setting is **Dedicated LAN**.

#### Configuration Address Source

Use this feature to select the source of the IP address for this computer. If Static is selected, you will need to know the IP address of this computer and enter it to the system manually in the field. If DHCP is selected, the BIOS will search for a DHCP (Dynamic Host Configuration Protocol) server in the network that it is attached to and request the next available IP address for this computer. The options are **DHCP** and Static.

***\*If the feature above is set to Static, the Station IP Address/Subnet Mask/Gateway IP Address features are available for configuration:***

#### Station MAC Address

#### Station IP Address

This feature displays the Station IP address for this computer. This should be in decimal and in dotted quad form (i.e., 192.168.10.253).

#### Subnet Mask

This feature displays the sub-network that this computer belongs to. The value of each three-digit number separated by dots should not exceed 255.

### **Station MAC Address**

This feature displays the Station MAC address for this computer. Mac addresses are 6 two-digit hexadecimal numbers.

### **Gateway IP Address**

This feature displays the Gateway IP address for this computer. This should be in decimal and in dotted quad form (i.e., 192.168.10.253).

### **VLAN**

This feature is configurable if the Update IPMI LAN Configuration feature is set to Yes. Use this feature to enable or disable the IPMI VLAN function. The options are **Disable** and **Enable**.

***\*If the feature above is set to Enable, the VLAN ID feature below is available for configuration:***

### **VLAN ID**

Use this feature to select a value for VLAN ID. Enter a number between 0-4095.

### **Configure IPV6 support**

#### **IPV6 Support**

Use this feature to enable IPV6 support. The options are **Enabled** and **Disabled**.

#### **Configuration Address Source**

Use this feature to select the source of the IP address for this computer. If Static is selected, you will need to know the IP address of this computer and enter it into the system manually in the field. If DHCP is selected, the BIOS will search for a DHCP (Dynamic Host Configuration Protocol) server in the network that is attached to and request the next available IP address for this computer. The options are **Static** and **DHCP**.

***\*If the feature above is set to Static, the Station IP Address/Prefix Length/IPV6 Router1 IP Address features are available for configuration:***

#### **Station IPV6 Address**

Use this feature to enter the IPV6 address.

#### **Prefix Length**

Use this feature to change the prefix length.

#### **IPV6 Router1 IP Address**

Use this feature to change the IPV6 Router1 IP address.

## 6.5 Security

Use this tab page to configure Security settings.

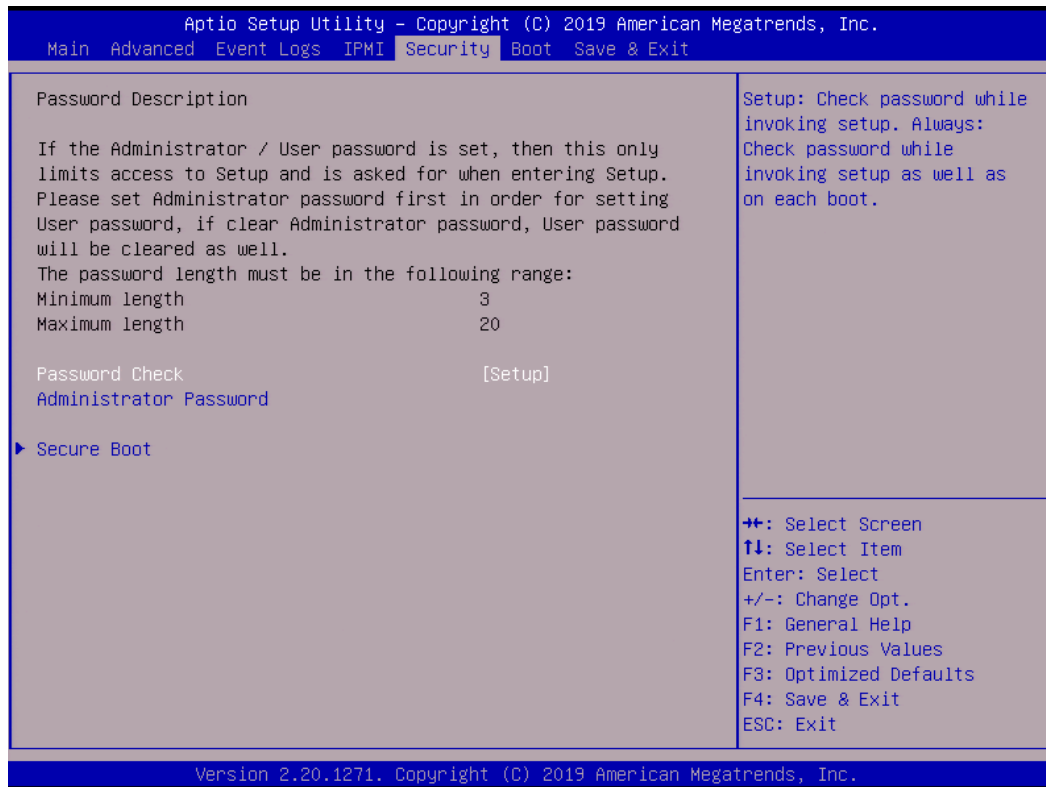

### Administrator Password

Use this feature to set the administrator password which is required to enter the BIOS setup utility. The length of the password should be from 3 to 20 characters long.

### Password Check

Select Setup for the system to check for a password at Setup. Select Always for the system to check for a password at bootup or upon entering the BIOS Setup utility. The options are **Setup** and **Always**.

### ► Secure Boot

- System Mode
- Vendor Keys
- Secure Boot

### Secure Boot

Select Enable for secure boot support to ensure system security at boot up. The options are **Disabled** and **Enabled**.

### **Secure Boot Mode**

This feature allows the user to select the desired secure boot mode for the system. The options are Standard and **Custom**.

***\*If Secure Boot Mode is set to Customized, Key Management features are available for configuration:***

### **CSM Support**

Select Enabled to support the EFI Compatibility Support Module (CSM), which provides compatibility support for traditional legacy BIOS for system boot. The options are Disabled and **Enabled**.

### **Vendor Keys**

#### **▶ Install Factory Default Keys**

Select Yes to install all factory keys to the default settings. The options are Yes and No.

#### **▶ Key Management**

##### **Factory Key Provision**

Select Enabled to install the default Secure Boot keys set by the manufacturer. The options are **Disabled** and Enabled.

##### **▶ Restore Factory Keys**

Select Yes to restore all factory keys to the default settings. The options are Yes and No.

##### **▶ Reset to Setup Mode**

Select Yes to delete all Secure Boot key databases and force the system to Setup Mode. The options are Yes and No.

##### **▶ Export Secure Boot variables**

Use this feature to copy the NVRAM contents of the secure boot variables to a file.

##### **▶ Enroll Efi Image**

This feature allows the image to run in Secure Boot mode.

### **Device Guard Ready**

#### **▶ Remove 'UEFI CA' from DB**

Use this feature to remove the Microsoft UEFI CA certificate from the database. The options are Yes and No.

#### **▶ Restore DB defaults**

Select Yes to restore all DBs to the default settings. The options are Yes and No.

**Secure Boot variable****▶ Platform Key (PK)****Details**

Select this feature to view the details of the Platform Key.

**Export**

Select Yes to export a PK from a file on an external media.

**Update**

Select Yes to load a factory default PK or No to load from a file on an external media.

**Delete**

Select Ok to remove the PK and then the system will reset to Setup/Audit Mode.

**▶ Key Exchange Keys****Details**

Select this feature to view the details of the Key Exchange Key.

**Export**

Select Yes to export a KEK from a file on an external media.

**Update**

Select Yes to load a factory default KEK or No to load from a file on an external media.

**Append**

Select Yes to add the KEK from the manufacturer's defaults list to the existing KEK. Select No to load the KEK from a file. The options are Yes and No.

**Delete**

Select Ok to remove the KEK and then the system will reset to Setup/Audit Mode.

**▶ Authorized Signatures****Details**

Select this feature to view the details of the db.

**Export**

Select Yes to export a db from a file on an external media.

**Update**

Select Yes to load a factory default db or No to load from a file on an external media.

**Append**

Select Yes to add the db from the manufacturer's defaults list to the existing db. Select No to load the db from a file. The options are Yes and No.

**Delete**

Select Ok to remove the db and then the system will reset to Setup/Audit Mode.

▶ **Forbidden Signatures**

**Details**

Select this feature to view the details of the dbx.

**Export**

Select Yes to export a dbx from a file on an external media.

**Update**

Select Yes to load a factory default dbx or No to load from a file on an external media.

**Append**

Select Yes to add the dbx from the manufacturer's defaults list to the existing dbx. Select No to load the dbx from a file. The options are Yes and No.

**Delete**

Select Ok to remove the dbx and then the system will reset to Setup/Audit Mode.

▶ **Authorized TimeStamps**

**Details**

Select this feature to view the details of the dbt.

**Export**

Select Yes to export a dbt from a file on an external media.

**Update**

Select Yes to load a factory default dbt or No to load from a file on an external media.

**Append**

Select Yes to add the dbt from the manufacturer's defaults list to the existing dbt. Select No to load the dbt from a file. The options are Yes and No.

**Delete**

Select Ok to remove the dbt and then the system will reset to Setup/Audit Mode.

**► OsRecovery Signatures****Details**

Select this feature to view the details of the dbr.

**Export**

Select Yes to export a dbr from a file on an external media.

**Update**

Select Yes to load a factory default dbr or No to load from a file on an external media.

**Append**

Select Yes to add the dbr from the manufacturer's defaults list to the existing dbr. Select No to load the dbr from a file. The options are Yes and No.

**Delete**

Select Ok to remove the dbr and then the system will reset to Setup/Audit Mode.

## 6.6 Event Logs

Use this tab page to configure Event Log settings.

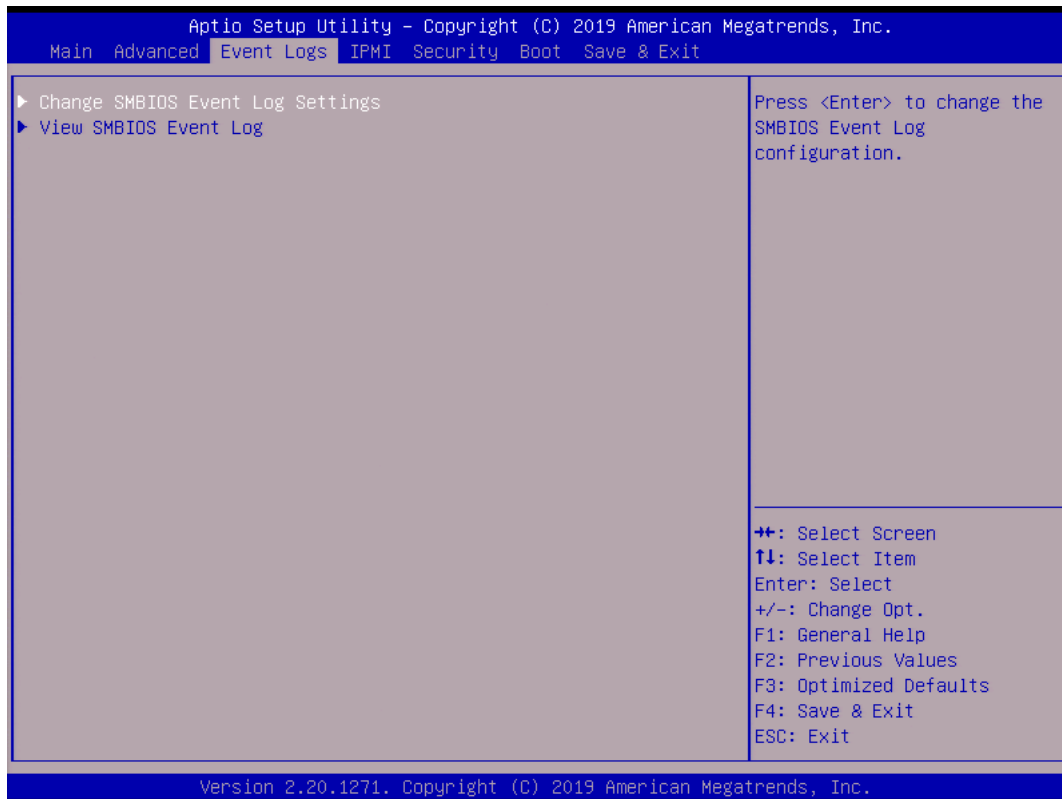

### ► Change SMBIOS Event Log Settings

#### Enabling/Disabling Options

##### Smbios Event Log

Change this feature to enable or disable all features of the SMBIOS Event Logging during system boot. The options are Disabled and **Enabled**.

#### Erasing Settings

##### Erase Event Log

Select Enabled to erase all error events in the SMBIOS (System Management BIOS) log before an event logging is initialized at bootup. The options are **No**, Yes, Next reset, and Yes, Every reset.

#### When Log is Full

Select Erase Immediately to immediately erase all errors in the SMBIOS event log when the event log is full. Select Do Nothing for the system to do nothing when the SMBIOS event log is full. The options are **Do Nothing** and Erase Immediately.

## Smbios Event Log Standard Settings

### Log System Boot Event

Select Enabled to log system boot events. The options are Enabled and **Disabled**.

### MECI (Multiple Event Count Increment)

Enter the increment value for the multiple event counter. Enter a number between 1 to 255. The default setting is 1.

### METW (Multiple Event Count Time Window)

This feature is used to determine how long (in minutes) should the multiple event counter wait before generating a new event log. Enter a number between 0 to 99. The default setting is **60**.

**Note:** Please reboot the system for the changes to take effect.

## ►View Smbios Event Log

This feature allows the user to view the event in the SMBIOS event log. The following categories are displayed:

**DATE/TIME/ERROR CODE/SEVERITY**

## 6.7 Boot

Use this tab page to configure Boot Settings.

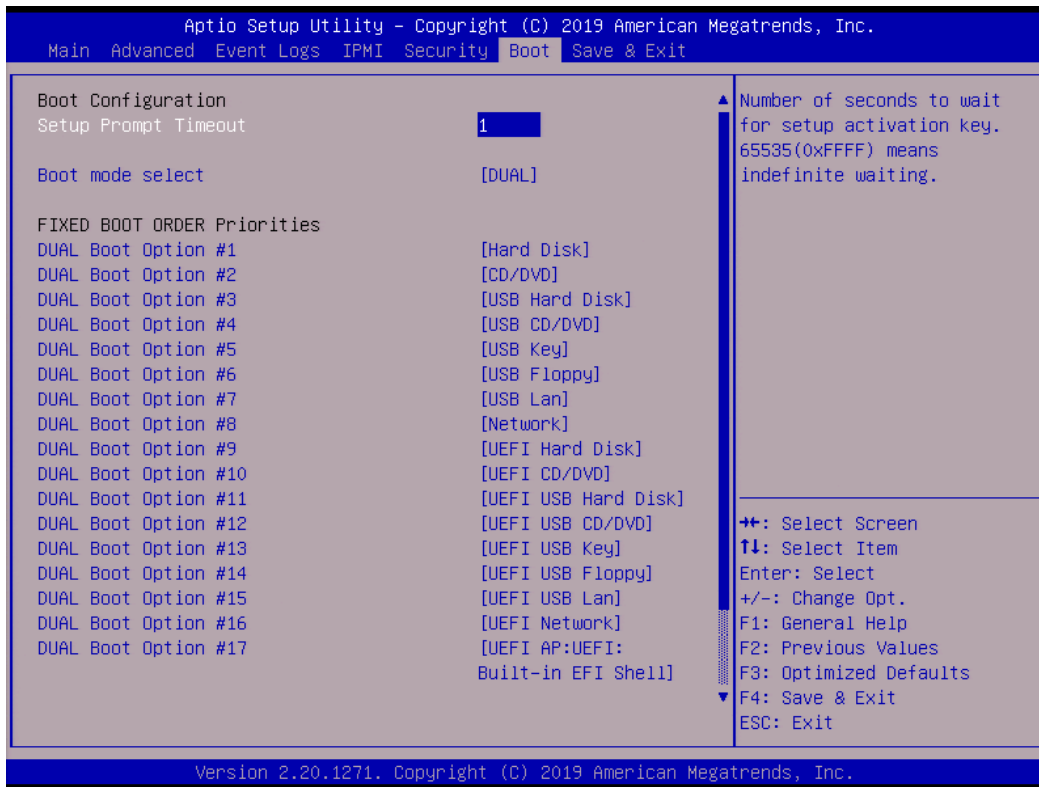

### Setup Prompt Timeout

Use this feature to specify the length of time (the number of seconds) for the BIOS to wait before rebooting the system when the setup activation key is pressed. Enter the value of 65535 (0xFFFF) for the BIOS to wait indefinitely. The default setting is **1**.

### Boot mode select

Use this feature to select the boot mode. The options are LEGACY, UEFI, and **DUAL**.

### Fixed BOOT ORDER Priorities

This option prioritizes the order of bootable devices that the system can boot from. Press <Enter> on each entry from top to bottom to select devices.

- LEGACY/UEFI/DUAL Boot Order #1
- LEGACY/UEFI/DUAL Boot Order #2
- LEGACY/UEFI/DUAL Boot Order #3
- LEGACY/UEFI/DUAL Boot Order #4
- LEGACY/UEFI/DUAL Boot Order #5
- LEGACY/UEFI/DUAL Boot Order #6
- LEGACY/UEFI/DUAL Boot Order #7
- LEGACY/UEFI/DUAL Boot Order #8
- LEGACY/UEFI/DUAL Boot Order #9
- LEGACY/UEFI/DUAL Boot Order #10
- LEGACY/UEFI/DUAL Boot Order #11
- LEGACY/UEFI/DUAL Boot Order #12
- LEGACY/UEFI/DUAL Boot Order #13
- LEGACY/UEFI/DUAL Boot Order #14
- LEGACY/UEFI/DUAL Boot Order #15
- LEGACY/UEFI/DUAL Boot Order #16
- LEGACY/UEFI/DUAL Boot Order #17

#### ►Delete Boot Option

Use this feature to select a boot device to delete from the boot priority list.

#### ►Delete Driver Option

Use this feature to remove an EFI driver option from the driver order.

#### ►UEFI Application Boot Priorities

- Boot Option # - This feature sets the system boot order of detected devices. The options are **[the list of detected boot device(s)]** and Disabled.

## 6.8 Save & Exit

Use this tab page to configure Save & Exit settings.

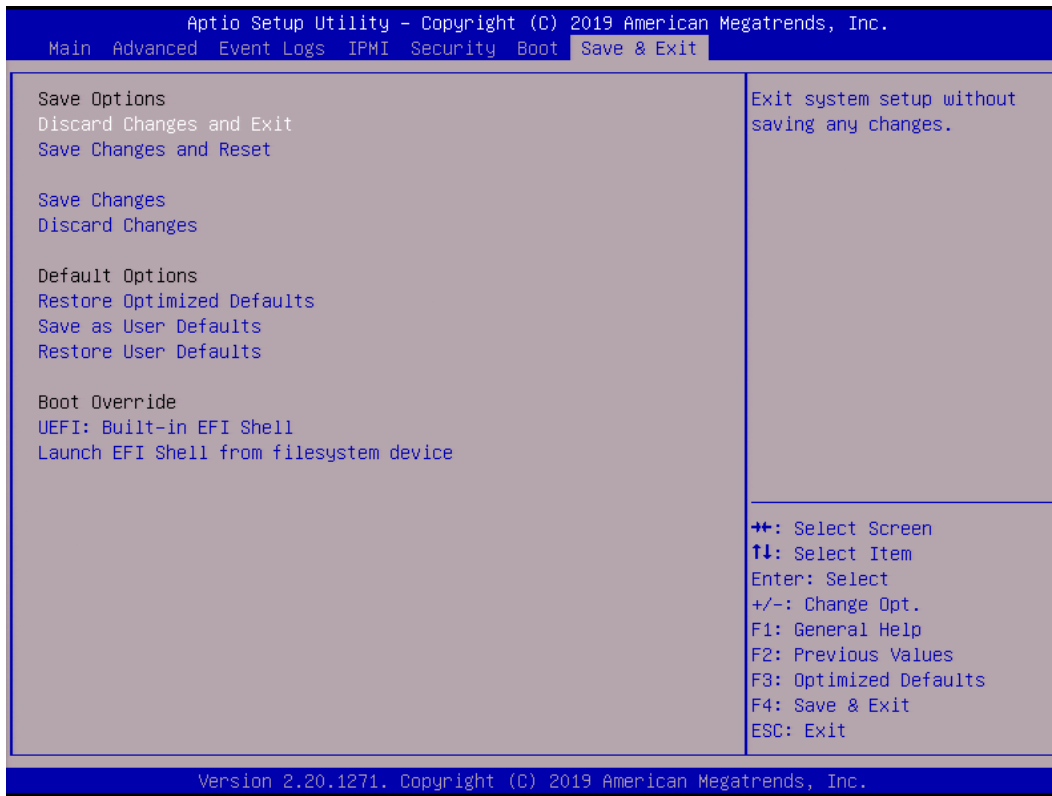

### Save Options

#### Discard Changes and Exit

Select this feature to quit the BIOS Setup without making any permanent changes to the system configuration and reboot the computer. Select Discard Changes and Exit from the Exit menu and press <Enter>.

#### Save Changes and Reset

When you have completed the system configuration changes, select this option to save all changes made and reset the system.

#### Save Changes

When you have completed the system configuration changes, select this option to save all changes made. This will not reset (reboot) the system.

#### Discard Changes

Select this option and press <Enter> to discard all the changes and return to the AMI BIOS Utility Program.

**Default Options****Restore Defaults**

To set this feature, select Restore Optimized Defaults and press <Enter>. These are factory settings designed for maximum system performance but not for maximum stability.

**Save as User Defaults**

To set this feature, select Save as User Defaults from the Exit menu and press <Enter>. This enables the user to save any changes to the BIOS setup for future use.

**Restore User Defaults**

To set this feature, select Restore User Defaults from the Exit menu and press <Enter>. Use this feature to retrieve user-defined settings that were saved previously.

**Boot Override**

Other boot options are listed in this section. The system will boot to the selected boot option.

**IBA GE Slot 00FE v0113****UEFI: Built-in EFI Shell****Launch EFI Shell from filesystem device**

# Appendix A

## BIOS Error Codes

### A.1 BIOS Error Beep (POST) Codes

During the POST (Power-On Self-Test) routines, which are performed each time the system is powered on, errors may occur.

**Non-fatal errors** are those which, in most cases, allow the system to continue the boot-up process. The error messages normally appear on the screen.

**Fatal errors** are those which will not allow the system to continue the boot-up procedure. If a fatal error occurs, you should consult with your system manufacturer for possible repairs.

These fatal errors are usually communicated through a series of audible beeps. The table below lists some common errors and their corresponding beep codes encountered by users.

BIOS Error Beep (POST) Codes		
Beep Code	Error Message	Description
1 short	Refresh	Circuits have been reset (Ready to power up)
5 short, 1 long	Memory error	No memory detected in system
5 long, 2 short	Display memory read/write error	Video adapter missing or with faulty memory
1 long continuous	System OH	System overheat condition

### A.2 Additional BIOS POST Codes

The AMI BIOS supplies additional checkpoint codes, which are documented online at <http://www.supermicro.com/support/manuals/> ("AMI BIOS POST Codes User's Guide").

When BIOS performs the Power On Self Test, it writes checkpoint codes to I/O port 0080h. If the computer cannot complete the boot process, a diagnostic card can be attached to the computer to read I/O port 0080h (Supermicro p/n AOC-LPC80-20).

For information on AMI updates, please refer to <http://www.ami.com/products/>.

## Appendix B

# Standardized Warning Statements for AC Systems

### About Standardized Warning Statements

The following statements are industry standard warnings, provided to warn the user of situations which have the potential for bodily injury. Should you have questions or experience difficulty, contact Supermicro's Technical Support department for assistance. Only certified technicians should attempt to install or configure components.

Read this appendix in its entirety before installing or configuring components in the Supermicro chassis.

These warnings may also be found on our website at [http://www.supermicro.com/about/policies/safety\\_information.cfm](http://www.supermicro.com/about/policies/safety_information.cfm).

### Warning Definition



**Warning!** This warning symbol means danger. You are in a situation that could cause bodily injury. Before you work on any equipment, be aware of the hazards involved with electrical circuitry and be familiar with standard practices for preventing accidents.

#### 警告の定義

この警告サインは危険を意味します。

人身事故につながる可能性がありますので、いずれの機器でも動作させる前に、電気回路に含まれる危険性に注意して、標準的な事故防止策に精通して下さい。

此警告符号代表危險。

您正处于可能受到严重伤害的工作环境中。在您使用设备开始工作之前，必须充分意识到触电的危险，并熟练掌握防止事故发生的标准工作程序。请根据每项警告结尾的声明号码找到此设备的安全性警告说明的翻译文本。

此警告符號代表危險。

您正處於可能身體可能會受損傷的工作環境中。在您使用任何設備之前，請注意觸電的危險，並且要熟悉預防事故發生的標準工作程序。請依照每一注意事項後的號碼找到相關的翻譯說明內容。

## Warnung

## WICHTIGE SICHERHEITSHINWEISE

Dieses Warnsymbol bedeutet Gefahr. Sie befinden sich in einer Situation, die zu Verletzungen führen kann. Machen Sie sich vor der Arbeit mit Geräten mit den Gefahren elektrischer Schaltungen und den üblichen Verfahren zur Vorbeugung vor Unfällen vertraut. Suchen Sie mit der am Ende jeder Warnung angegebenen Anweisungsnummer nach der jeweiligen Übersetzung in den übersetzten Sicherheitshinweisen, die zusammen mit diesem Gerät ausgeliefert wurden.

BEWAHREN SIE DIESE HINWEISE GUT AUF.

## INSTRUCCIONES IMPORTANTES DE SEGURIDAD

Este símbolo de aviso indica peligro. Existe riesgo para su integridad física. Antes de manipular cualquier equipo, considere los riesgos de la corriente eléctrica y familiarícese con los procedimientos estándar de prevención de accidentes. Al final de cada advertencia encontrará el número que le ayudará a encontrar el texto traducido en el apartado de traducciones que acompaña a este dispositivo.

GUARDE ESTAS INSTRUCCIONES.

## IMPORTANTES INFORMATIONS DE SÉCURITÉ

Ce symbole d'avertissement indique un danger. Vous vous trouvez dans une situation pouvant entraîner des blessures ou des dommages corporels. Avant de travailler sur un équipement, soyez conscient des dangers liés aux circuits électriques et familiarisez-vous avec les procédures couramment utilisées pour éviter les accidents. Pour prendre connaissance des traductions des avertissements figurant dans les consignes de sécurité traduites qui accompagnent cet appareil, référez-vous au numéro de l'instruction situé à la fin de chaque avertissement.

CONSERVEZ CES INFORMATIONS.

תקנון הזהרות אזהרה

הזהרות הבאות הן אזהרות על פי תקני התעשייה, על מנת להזהיר את המשתמש מפני חבלה פיזית אפשרית. במידה ויש שאלות או היתקלות בבעיה כלשהי, יש ליצור קשר עם מחלקת תמיכה טכנית של סופרמיקרו. טכנאים מוסמכים בלבד רשאים להתקין או להגדיר את הרכיבים. יש לקרוא את הנספח במלואו לפני התקנת או הגדרת הרכיבים במארזי סופרמיקרו.

اَكْ ف حالة وُكِي اَي تتسبب ف اصابة جسدهُ هذا الزهز عْ خطر! تحذُرُ .  
قبل اَي تعول على اَي هعدات، كي على علن بالوخاطز ال اُجوة عي الذوائر  
الكهزبائِة  
وكي على دراةُ بالووارسات النقاائِة لو عْ وقع اَي حادث  
استخدم رقن الب اِي الو صُص ف هاةُ كل تحذُرُ للعشر تزجوتها

안전을 위한 주의사항

경고!

이 경고 기호는 위험이 있음을 알려 줍니다. 작업자의 신체에 부상을 야기 할 수 있는 상태에 있게 됩니다. 모든 장비에 대한 작업을 수행하기 전에 전기회로와 관련된 위험요소들을 확인하시고 사전에 사고를 방지할 수 있도록 표준 작업절차를 준수해 주시기 바랍니다.

해당 번역문을 찾기 위해 각 경고의 마지막 부분에 제공된 경고문 번호를 참조하십시오

## BELANGRIJKE VEILIGHEIDSINSTRUCTIES

Dit waarschuwings symbool betekent gevaar. U verkeert in een situatie die lichamelijk letsel kan veroorzaken. Voordat u aan enige apparatuur gaat werken, dient u zich bewust te zijn van de bij een elektrische installatie betrokken risico's en dient u op de hoogte te zijn van de standaard procedures om ongelukken te voorkomen. Gebruik de nummers aan het eind van elke waarschuwing om deze te herleiden naar de desbetreffende locatie.

BEWAAR DEZE INSTRUCTIES

## Installation Instructions



**Warning!** Read the installation instructions before connecting the system to the power source.

### 設置手順書

システムを電源に接続する前に、設置手順書をお読み下さい。

### 警告

将此系统连接电源前,请先阅读安装说明。

### 警告

將系統與電源連接前，請先閱讀安裝說明。

Warnung

Vor dem Anschließen des Systems an die Stromquelle die Installationsanweisungen lesen.

¡Advertencia!

Lea las instrucciones de instalación antes de conectar el sistema a la red de alimentación.

Attention

Avant de brancher le système sur la source d'alimentation, consulter les directives d'installation.

יש לקרוא את הוראות התקנה לפני חיבור המערכת למקור מתח.

اقر إرشادات التركيب قبل توصيل النظام إلى مصدر للطاقة

시스템을 전원에 연결하기 전에 설치 안내를 읽어주십시오.

Waarschuwing

Raadpleeg de installatie-instructies voordat u het systeem op de voedingsbron aansluit.

## Circuit Breaker



**Warning!** This product relies on the building's installation for short-circuit (overcurrent) protection. Ensure that the protective device is rated not greater than: 250 V, 20 A.

サーキット・ブレーカー

この製品は、短絡(過電流)保護装置がある建物での設置を前提としています。

保護装置の定格が250 V、20 Aを超えないことを確認下さい。

警告

此产品的短路(过载电流)保护由建筑物的供电系统提供,确保短路保护设备的额定电流不大于250V,20A。

警告

此產品的短路(過載電流)保護由建築物的供電系統提供,確保短路保護設備的額定電流不大於250V,20A。

### Warnung

Dieses Produkt ist darauf angewiesen, dass im Gebäude ein Kurzschluss- bzw. Überstromschutz installiert ist. Stellen Sie sicher, dass der Nennwert der Schutzvorrichtung nicht mehr als: 250 V, 20 A beträgt.

### ¡Advertencia!

Este equipo utiliza el sistema de protección contra cortocircuitos (o sobrecorrientes) del edificio. Asegúrese de que el dispositivo de protección no sea superior a: 250 V, 20 A.

### Attention

Pour ce qui est de la protection contre les courts-circuits (surtension), ce produit dépend de l'installation électrique du local. Vérifiez que le courant nominal du dispositif de protection n'est pas supérieur à :250 V, 20 A.

מוצר זה מסתמך על הגנה המותקנת במבנים למניעת קצר חשמלי. יש לוודא כי המכשיר המגן מפני הקצר החשמלי הוא לא יותר מ-250VDC, 20A.

هذا المنتج يعتمد على معدات الحماية مه الدوائر القصيرة التي تم تثبيتها في المبنى  
تأكد من أن تقييم الجهاز الوقائي ليس أكثر من : 20A, 250V

### 경고!

이 제품은 전원의 단락(과전류)방지에 대해서 전적으로 건물의 관련 설비에 의존합니다. 보호장치의 정격이 반드시 250V(볼트), 20A(암페어)를 초과하지 않도록 해야 합니다.

### Waarschuwing

Dit product is afhankelijk van de kortsluitbeveiliging (overspanning) van uw elektrische installatie. Controleer of het beveiligde apparaat niet groter gedimensioneerd is dan 250V, 20A.

## Power Disconnection Warning



**Warning!** The system must be disconnected from all sources of power and the power cord removed from the power supply module(s) before accessing the chassis interior to install or remove system components.

### 電源切斷の警告

システムコンポーネントの取り付けまたは取り外しのために、シャーシ内部にアクセスするには、システムの電源はすべてのソースから切斷され、電源コードは電源モジュールから取り外す必要があります。

### 警告

在你打开机箱并安装或移除内部器件前,必须将系统完全断电,并移除电源线。

### 警告

在您打開機殼安裝或移除內部元件前，必須將系統完全斷電，並移除電源線。

### Warnung

Das System muss von allen Quellen der Energie und vom Netzanschlusskabel getrennt sein, das von den Spg.Versorgungsteilmodulen entfernt wird, bevor es auf den Chassisinnenraum zurückgreift, um Systemsbestandteile anzubringen oder zu entfernen.

### ¡Advertencia!

El sistema debe ser disconnected de todas las fuentes de energía y del cable eléctrico quitado de los módulos de fuente de alimentación antes de tener acceso el interior del chasis para instalar o para quitar componentes de sistema.

### Attention

Le système doit être débranché de toutes les sources de puissance ainsi que de son cordon d'alimentation secteur avant d'accéder à l'intérieur du chasis pour installer ou enlever des composants de système.

אזהרה מפני ניתוק חשמלי

אזהרה!

יש לנתק את המערכת מכל מקורות החשמל ויש להסיר את כבל החשמלי מהספק לפני גישה לחלק הפנימי של המארז לצורך התקנת או הסרת רכיבים.

يجب فصل انظاؤ من جميع مصادر انطاقت وإزانت سهك انكهرباء من وحدة امداد  
انطاقت قيم  
انصل إلى امناطق انداخهيت نههيكم نتشيج أو إزانت مكناث الجهاز

경고!

시스템에 부품들을 장착하거나 제거하기 위해서는 새시 내부에 접근하기 전에 반드시 전원 공급장치로부터 연결되어있는 모든 전원과 전기코드를 분리해주어야 합니다.

Waarschuwing

Voordat u toegang neemt tot het binnenwerk van de behuizing voor het installeren of verwijderen van systeem onderdelen, dient u alle spanningsbronnen en alle stroomkabels aangesloten op de voeding(en) van de behuizing te verwijderen

## Equipment Installation



**Warning!** Only trained and qualified personnel should be allowed to install, replace, or service this equipment.

機器の設置

トレーニングを受け認定された人だけがこの装置の設置、交換、またはサービスを許可されていま  
す。

警告

只有经过培训且具有资格的人员才能进行此设备的安装、更换和维修。

警告

只有經過受訓且具資格人員才可安裝、更換與維修此設備。

Warnung

Das Installieren, Ersetzen oder Bedienen dieser Ausrüstung sollte nur geschultem, qualifiziertem Personal gestattet werden.

¡Advertencia!

Solamente el personal calificado debe instalar, reemplazar o utilizar este equipo.

**Attention**

Il est vivement recommandé de confier l'installation, le remplacement et la maintenance de ces équipements à des personnels qualifiés et expérimentés.

אזהרה!

צוות מוסמך בלבד רשאי להתקין, להחליף את הציוד או לתת שירות עבור הציוד.

والمدربيه لتزكيب واستبدال أو خدمة هذا الجهاز يجب أن يسمح فقط للمظفيه المؤهليه

경고!

훈련을 받고 공인된 기술자만이 이 장비의 설치, 교체 또는 서비스를 수행할 수 있습니다.

**Waarschuwing**

Deze apparatuur mag alleen worden geïnstalleerd, vervangen of hersteld door geschoold en gekwalificeerd personeel.

**Restricted Area**

**Warning!** This unit is intended for installation in restricted access areas. A restricted access area can be accessed only through the use of a special tool, lock and key, or other means of security. (This warning does not apply to workstations).

**アクセス制限区域**

このユニットは、アクセス制限区域に設置されることを想定しています。

アクセス制限区域は、特別なツール、鍵と錠前、その他のセキュリティの手段を用いてのみ出入りが可能です。

**警告**

此部件应安装在限制进出的场所，限制进出的场所指只能通过使用特殊工具、锁和钥匙或其它安全手段进出的场所。

**警告**

此装置僅限安裝於進出管制區域，進出管制區域係指僅能以特殊工具、鎖頭及鑰匙或其他安全方式才能進入的區域。

### Warnung

Diese Einheit ist zur Installation in Bereichen mit beschränktem Zutritt vorgesehen. Der Zutritt zu derartigen Bereichen ist nur mit einem Spezialwerkzeug, Schloss und Schlüssel oder einer sonstigen Sicherheitsvorkehrung möglich.

### ¡Advertencia!

Esta unidad ha sido diseñada para instalación en áreas de acceso restringido. Sólo puede obtenerse acceso a una de estas áreas mediante la utilización de una herramienta especial, cerradura con llave u otro medio de seguridad.

### Attention

Cet appareil doit être installé dans des zones d'accès réservés. L'accès à une zone d'accès réservé n'est possible qu'en utilisant un outil spécial, un mécanisme de verrouillage et une clé, ou tout autre moyen de sécurité.

אזור עם גישה מוגבלת

אזהרה!

יש להתקין את היחידה באזורים שיש בהם הגבלת גישה. הגישה ניתנת בעזרת 'כלי אבטחה בלבד' (מפתח, מנעול וכד.).

تخصيص هذه انحدة نترك بُها ف مناطق محظورة تم .  
ممكن اننصل إن منطقت محظورة فقط من خلال استخذاو أداة خاصت  
أو أ وس هُت أخري نلالأمما ققم ومفتاح

### 경고!

이 장치는 접근이 제한된 구역에 설치하도록 되어있습니다. 특수도구, 잠금 장치 및 키, 또는 기타 보안 수단을 통해서만 접근 제한 구역에 들어갈 수 있습니다.

### Waarschuwing

Dit apparaat is bedoeld voor installatie in gebieden met een beperkte toegang. Toegang tot dergelijke gebieden kunnen alleen verkregen worden door gebruik te maken van speciaal gereedschap, slot en sleutel of andere veiligheidsmaatregelen.

## Battery Handling



**Warning!** There is the danger of explosion if the battery is replaced incorrectly. Replace the battery only with the same or equivalent type recommended by the manufacturer. Dispose of used batteries according to the manufacturer's instructions

### 電池の取り扱い

電池交換が正しく行われなかった場合、破裂の危険性があります。交換する電池はメーカーが推奨する型、または同等のものを使用下さい。使用済電池は製造元の指示に従って処分して下さい。

### 警告

電池更換不當會有爆炸危險。請只使用同類電池或制造商推薦的功能相當的電池更換原有電池。請按製造商的說明處理廢舊電池。

### 警告

電池更換不當會有爆炸危險。請使用製造商建議之相同或功能相當的電池更換原有電池。請按照製造商的說明指示處理廢棄舊電池。

### Warnung

Bei Einsetzen einer falschen Batterie besteht Explosionsgefahr. Ersetzen Sie die Batterie nur durch den gleichen oder vom Hersteller empfohlenen Batterietyp. Entsorgen Sie die benutzten Batterien nach den Anweisungen des Herstellers.

### Attention

Danger d'explosion si la pile n'est pas remplacée correctement. Ne la remplacer que par une pile de type semblable ou équivalent, recommandée par le fabricant. Jeter les piles usagées conformément aux instructions du fabricant.

### ¡Advertencia!

Existe peligro de explosión si la batería se reemplaza de manera incorrecta. Reemplazar la batería exclusivamente con el mismo tipo o el equivalente recomendado por el fabricante. Desechar las baterías gastadas según las instrucciones del fabricante.

אזהרה!

קיימת סכנת פיצוץ של הסוללה במידה והוחלפה בדרך לא תקינה. יש להחליף את הסוללה בסוג התואם מחברת יצרן מומלצת. סילוק הסוללות המשומשות יש לבצע לפי הוראות היצרן.

هناك خطر من انفجار في حالة اسبدال البطارية بطريقة غير صحيحة فعلى  
اسبدال البطارية  
فقط بنفس النوع أو ما يعادلها مما أوصت به الشركة المصنعة  
جخلص من البطاريات المسحومة وفقا لعمليات الشركة الصانعة

경고!

배터리가 올바르게 교체되지 않으면 폭발의 위험이 있습니다. 기존 배터리와 동일하거나 제조사에서 권장하는 동등한 종류의 배터리로만 교체해야 합니다. 제조사의 안내에 따라 사용된 배터리를 처리하여 주십시오.

Waarschuwing

Er is ontplofingsgevaar indien de batterij verkeerd vervangen wordt. Vervang de batterij slechts met hetzelfde of een equivalent type die door de fabrikant aanbevolen wordt. Gebruikte batterijen dienen overeenkomstig fabrieksvoorschriften afgevoerd te worden.

## Redundant Power Supplies



**Warning!** This unit might have more than one power supply connection. All connections must be removed to de-energize the unit.

冗長電源装置

このユニットは複数の電源装置が接続されている場合があります。

ユニットの電源を切るためには、すべての接続を取り外さなければなりません。

警告

此部件连接的电源可能不止一个，必须将所有电源断开才能停止给该部件供电。

警告

此装置连接的电源可能不只一个，必须切断所有电源才能停止对该装置的供电。

Warnung

Dieses Gerät kann mehr als eine Stromzufuhr haben. Um sicherzustellen, dass der Einheit kein Strom zugeführt wird, müssen alle Verbindungen entfernt werden.

¡Advertencia!

Puede que esta unidad tenga más de una conexión para fuentes de alimentación. Para cortar por completo el suministro de energía, deben desconectarse todas las conexiones.

Attention

Cette unité peut avoir plus d'une connexion d'alimentation. Pour supprimer toute tension et tout courant électrique de l'unité, toutes les connexions d'alimentation doivent être débranchées.

אם קיים יותר מספק אחד

אזהרה!

ליחידה יש יותר מחיבור אחד של ספק. יש להסיר את כל החיבורים על מנת לרוקן את היחידה.

قد يكون لهذا الجهاز عدة اتصالات بوحدات امداد الطاقة .

يجب إزالة كافة الاتصالات لعسل الوحدة عن الكهرباء

경고!

이 장치에는 한 개 이상의 전원 공급 단자가 연결되어 있을 수 있습니다. 이 장치에 전원을 차단하기 위해서는 모든 연결 단자를 제거해야만 합니다.

Waarschuwing

Deze eenheid kan meer dan één stroomtoevoeraansluiting bevatten. Alle aansluitingen dienen verwijderd te worden om het apparaat stroomloos te maken.

## Backplane Voltage



**Warning!** Hazardous voltage or energy is present on the backplane when the system is operating. Use caution when servicing.

### バックプレーンの電圧

システムの稼働中は危険な電圧または電力が、バックプレーン上にかかっています。

修理する際には注意ください。

### 警告

当システム正在进行时，背板上有很危险的电压或能量，进行维修时务必小心。

### 警告

當系統正在進行時，背板上危險的電壓或能量，進行維修時務必小心。

### Warnung

Wenn das System in Betrieb ist, treten auf der Rückwandplatine gefährliche Spannungen oder Energien auf. Vorsicht bei der Wartung.

### ¡Advertencia!

Cuando el sistema está en funcionamiento, el voltaje del plano trasero es peligroso. Tenga cuidado cuando lo revise.

### Attention

Lorsque le système est en fonctionnement, des tensions électriques circulent sur le fond de panier. Prendre des précautions lors de la maintenance.

מתח בפנל האחורי

אזהרה!

קיימת סכנת מתח בפנל האחורי בזמן תפעול המערכת. יש להיזהר במהלך העבודה.

هناك خطر من التيار الكهربائي أو الطاقة المتجددة على اللوحة  
عندما يكون النظام يعمل كه حذرا عند خدمة هذا الجهاز

경고!

시스템이 동작 중일 때 후면판 (Backplane)에는 위험한 전압이나 에너지가 발생 합니다.  
서비스 작업 시 주의하십시오.

Waarschuwing

Een gevaarlijke spanning of energie is aanwezig op de backplane wanneer het systeem in gebruik is. Voorzichtigheid is geboden tijdens het onderhoud.

## Comply with Local and National Electrical Codes



**Warning!** Installation of the equipment must comply with local and national electrical codes.

地方および国の電気規格に準拠

機器の取り付けはその地方および国の電気規格に準拠する必要があります。

警告

设备安装必须符合本地与本国电气法规。

警告

設備安裝必須符合本地與本國電氣法規。

Warnung

Die Installation der Geräte muss den Sicherheitsstandards entsprechen.

¡Advertencia!

La instalación del equipo debe cumplir con las normas de electricidad locales y nacionales.

Attention

L'équipement doit être installé conformément aux normes électriques nationales et locales.

תיאום חוקי החשמל הארצי

אזהרה!

התקנת הציוד חייבת להיות תואמת לחוקי החשמל המקומיים והארציים.

تركيب المعدات الكهربائية يجب أن يمتثل للقوايه المحلية والبطية المتعلقة

بالكهرباء

경고!

현 지역 및 국가의 전기 규정에 따라 장비를 설치해야 합니다.

Waarschuwing

Bij installatie van de apparatuur moet worden voldaan aan de lokale en nationale elektriciteitsvoorschriften.

## Product Disposal



**Warning!** Ultimate disposal of this product should be handled according to all national laws and regulations.

製品の廃棄

この製品を廃棄処分する場合、国の関係する全ての法律・条例に従い処理する必要があります。

警告

本产品的废弃处理应根据所有国家的法律和规章进行。

警告

本產品的廢棄處理應根據所有國家的法律和規章進行。

Warnung

Die Entsorgung dieses Produkts sollte gemäß allen Bestimmungen und Gesetzen des Landes erfolgen.

¡Advertencia!

Al deshacerse por completo de este producto debe seguir todas las leyes y reglamentos nacionales.

## Attention

La mise au rebut ou le recyclage de ce produit sont généralement soumis à des lois et/ou directives de respect de l'environnement. Renseignez-vous auprès de l'organisme compétent.

סילוק המוצר

אזהרה!

סילוק סופי של מוצר זה חייב להיות בהתאם להנחיות וחוקי המדינה.

التخلص النهائي من هذا المنتج ينبغي التعامل معه وفقا لجميع القوانين واللوائح الوطنية عند

## 경고!

이 제품은 해당 국가의 관련 법규 및 규정에 따라 폐기되어야 합니다.

## Waarschuwing

De uiteindelijke verwijdering van dit product dient te geschieden in overeenstemming met alle nationale wetten en reglementen.

## Hot Swap Fan Warning



**Warning!** Hazardous moving parts. Keep away from moving fan blades. The fans might still be turning when you remove the fan assembly from the chassis. Keep fingers, screwdrivers, and other objects away from the openings in the fan assembly's housing.

## ファン・ホットスワップの警告

警告!回転部品に注意。運転中は回転部(羽根)に触れないでください。シャーシから冷却ファン装置を取り外した際、ファンがまだ回転している可能性があります。ファンの開口部に、指、ドライバー、およびその他のものを近づけないで下さい。

## 警告!

警告! 危險的可移動性零件。請務必與轉動的風扇葉片保持距離。當您從機架移除風扇裝置，風扇可能仍在轉動。小心不要將手指、螺絲起子和其他物品太靠近風扇

## 警告

危險的可移動性零件。請務必與轉動的風扇葉片保持距離。當您從機架移除風扇裝置，風扇可能仍在轉動。小心不要將手指、螺絲起子和其他物品太靠近風扇。

### Warnung

Gefährlich Bewegende Teile. Von den bewegenden Lüfterblätter fern halten. Die Lüfter drehen sich u. U. noch, wenn die Lüfterbaugruppe aus dem Chassis genommen wird. Halten Sie Finger, Schraubendreher und andere Gegenstände von den Öffnungen des Lüftergehäuses entfernt.

### ¡Advertencia!

Riesgo de piezas móviles. Mantener alejado de las aspas del ventilador. Los ventiladores podran dar vuelta cuando usted quite el montaje del ventilador del chasis. Mantenga los dedos, los destornilladores y todos los objetos lejos de las aberturas del ventilador

### Attention

Pieces mobiles dangereuses. Se tenir a l'écart des lames du ventilateur Il est possible que les ventilateurs soient toujours en rotation lorsque vous retirerez le bloc ventilateur du châssis. Prenez garde à ce que doigts, tournevis et autres objets soient éloignés du logement du bloc ventilateur.

### אזהרה!

חלקים נעים מסוכנים. התרחק מלהבי המאוורר בפעולה כאשר מסירים את חלקי המאוורר מהמארז, יתכן והמאווררים עדיין עובדים. יש להרחיק למרחק בטוח את האצבעות וכלי עבודה שונים מהפתחים בתוך המאוורר

تحذير! أجزاء متحركة خطيرة. ابتعد عن شفرات المروحة المتحركة. من الممكن أن المراوح لا تزال تدور عند إزالة كتلة المروحة من الهيكل يجب إبقاء الأصابع ومفكات البراغي وغيرها من الأشياء بعيدا عن الفتحات في كتلة المروحة

### 경고!

움직이는 위험한 부품. 회전하는 송풍 날개에 접근하지 마세요. 새시로부터 팬 조립품을 제거할 때 팬은 여전히 회전하고 있을 수 있습니다. 팬 조립품 외관의 열려있는 부분들로부터 손가락 및 스크류드라이버, 다른 물체들이 가까이 하지 않도록 배치해 주십시오.

### Waarschuwing

Gevaarlijk bewegende onderdelen. Houd voldoende afstand tot de bewegende ventilatorbladen. Het is mogelijk dat de ventilator nog draait tijdens het verwijderen van het ventilatorsamenstel uit het chassis. Houd uw vingers, schroevendraaiers en eventuele andere voorwerpen uit de buurt van de openingen in de ventilatorbehuizing.

## Power Cable and AC Adapter



**Warning!** When installing the product, use the provided or designated connection cables, power cables and AC adaptors. Using any other cables and adaptors could cause a malfunction or a fire. Electrical Appliance and Material Safety Law prohibits the use of UL or CSA -certified cables (that have UL/CSA shown on the cord) for any other electrical devices than products designated by Supermicro only.

### 電源コードとACアダプター

製品を設置する場合、提供または指定および購入された接続ケーブル、電源コードとACアダプターを、該当する地域の条例や安全基準に適合するコードサイズやプラグと共に使用下さい。他のケーブルやアダプタを使用すると故障や火災の原因になることがあります。

電気用品安全法は、ULまたはCSA認定のケーブル(UL/CSEマークがコードに表記)を Supermicro が指定する製品以外に使用することを禁止しています。

### 警告

安装此产品时,请使用本身提供的或指定的或采购的连接线,电源线和电源适配器。包含遵照当地法规和安全要求的合规的电源线尺寸和插头。使用其它线材或适配器可能会引起故障或火灾。除了Supermicro所指定的产品,电气用品和材料安全法律规定禁止使用未经UL或CSA认证的线材。(线材上会显示UL/CSA符号)。

### 警告

安裝此產品時,請使用本身提供的或指定的或採購的連接線,電源線和電源適配器。包含遵照當地法規和安全要求的合規的電源線尺寸和插頭。使用其它線材或適配器可能會引起故障或火災。除了Supermicro所指定的產品,電氣用品和材料安全法律規定禁止使用未經UL或CSA認證的線材。(線材上會顯示UL/CSA符號)。

### Warnung

Nutzen Sie beim Installieren des Produkts ausschließlich die von uns zur Verfügung gestellten Verbindungskabeln, Stromkabeln und/oder Adapter, die Ihre örtlichen Sicherheitsstandards einhalten. Der Gebrauch von anderen Kabeln und Adapter können Fehlfunktionen oder Feuer verursachen. Die Richtlinien untersagen das Nutzen von UL oder CAS zertifizierten Kabeln (mit UL/CSA gekennzeichnet), an Geräten oder Produkten die nicht mit Supermicro gekennzeichnet sind.

### ¡Advertencia!

Cuando instale el producto, utilice la conexión provista o designada o procure cables, Cables de alimentación y adaptadores de CA que cumplan con los códigos locales y los requisitos de seguridad, incluyendo el tamaño adecuado del cable y el enchufe. El uso de otros cables y adaptadores podría causar un mal funcionamiento o un incendio. La Ley de Seguridad de Aparatos Eléctricos y de Materiales prohíbe El uso de cables certificados por UL o CSA (que tienen el certificado UL / CSA en el código) para cualquier otros dispositivos eléctricos que los productos designados únicamente por Supermicro.

### Attention

Lors de l'installation du produit, utilisez les cables de connection fournis ou désigné ou achetez des cables, cables de puissance et adaptateurs respectant les normes locales et les conditions de securite y compris les tailles de cables et les prises electriques appropries. L'utilisation d'autres cables et adaptateurs peut provoquer un dysfonctionnement ou un incendie. Appareils électroménagers et la Loi sur la Sécurité Matériel interdit l'utilisation de câbles certifiés- UL ou CSA (qui ont UL ou CSA indiqué sur le code) pour tous les autres appareils électriques sauf les produits désignés par Supermicro seulement.

AC ימאתמו מיילמשח מילבכ

!הרהזא

ךרוצל ומאתוה וא ושכרנ רשא AC מימאתמו מיקפס, מילבכב שמתשהל שי, רצומה תא מיניקתמ רשאכ לכב שומיש . עקתהו לבכה לש הנוכח הדימ ללוכ, תוימוקמה תוחיטבה תושירדל ומאתוה רשאו, הנקתהה למשחה ירישכמב שומישה יקוחל מאתהב. ילמשח רצק וא הלקתל מורגל לולע, רחא גוסמ מאתמ וא לבכ לש דוק מהילע עיפומ רשאכ) UL-ב או CSA-ב-ב מיכמסומה מילבכב שמתשהל רוסיא מייק, תוחיטבה יקוחו דבלב Supermicro י"ע מאתוה רשא רצומב קר אלא, רחא ילמשח רצומ לכ רובע (UL/CSA)

תאלבאלא אארשב מץ וא אדדחמלא וא ארפוטמלא תאליטוטלא מאדחטסאב מץ, אגתנמלא בייקרת דנע לכלז יפ אב אילחמלא אלאסלא תאבלטתמו נינאוץב מאזתלאל אע מדדרטמלא ראיטלא תאלוחמו אילברמלא אילי. וא לטע יפ בבסטטי דץ אירא תאלוחמו תאלבאלא יא מאדחטסא. מילסלא סבאלאו לטומוא מץ א. ו א UL לביק נמ אדמאמלא תאלבאלא מאדחטסא תאדעמלא אילברמלא אזהאלל אלאסלא נונאץ רזחי Supermicro לביק נמ אדדחמלא אילינעמלא תאגתנמלא ריי אירא תאדעמ יא אע (UL/CSA) אלאע למחתי אילאו

### 전원 케이블 및 AC 어댑터

경고! 제품을 설치할 때 현지 코드 및 적절한 굵기의 코드와 플러그를 포함한 안전 요구 사항을 준수하여 제공되거나 지정된 연결 혹은 구매 케이블, 전원 케이블 및 AC 어댑터를 사용하십시오.

다른 케이블이나 어댑터를 사용하면 오작동이나 화재가 발생할 수 있습니다. 전기 용품 안전법은 UL 또는 CSA 인증 케이블 (코드에 UL / CSA가 표시된 케이블)을 Supermicro 가 지정한 제품 이외의 전기 장치에 사용하는 것을 금지합니다.

### Stroomkabel en AC-Adapter

Waarschuwing! Bij het aansluiten van het Product uitsluitend gebruik maken van de geleverde Kabels of een andere geschikte aan te schaffen Aansluitmethode, deze moet altijd voldoen aan de lokale voorschriften en veiligheidsnormen, inclusief de juiste kabeldikte en stekker. Het gebruik van niet geschikte Kabels en/of Adapters kan een storing of brand veroorzaken. Wetgeving voor Elektrische apparatuur en Materiaalveiligheid verbied het gebruik van UL of CSA -gecertificeerde Kabels (met UL/CSA in de code) voor elke andere toepassing dan de door Supermicro hiervoor beoogde Producten.

# Appendix C

## System Specifications

### Processors (per node)

Single socket H4 (LGA 1151) supports Intel Xeon E-2100 Core i3 Pentium Celeron processor, 16 Threads, 95W, Intel C246

**Note:** Please refer to the motherboard specifications pages on our website for updates to supported processors.

### BIOS

128Mb UEFI

### Memory (per node)

Up to 128GB unbuffered ECC in four DIMM slots with speed of up to DDR4-2666MHz

### Storage Drives

Two 3.5" SATA3 drives or two 2.5" SATA3 with optional kits

### PCI Expansion Slots (per node)

One PCI-E 3.0 x8 LP open end slot

One MicroLP slot (MicroLP upgradeable)

Two PCI-E 3.0 x4

One M-Key 2280, 22110

### Input/Output (per node)

Two SATA3 (6Gbps) ports

Two RJ45 Gigabit Ethernet LAN ports

One RJ45 dedicated IPMI LAN port

### Motherboard

X11SCD-F 15.69" x 4.75" (398.5mm x 120.65mm)

### Chassis

SC938NH-R2K04BP; 3U rackmount; (WxHxD) 15.26 x 5.2 x 23 in. (387 x 132 x 585 mm)

### System Cooling

Four 8-cm heavy duty fans with optimal cooling zone

### Weight

Net Weight: 62.2lbs (28.21kg)

Gross Weight: 88lbs (39.92kg)

## Power Supply

Model: PWS-2K04A-1R, 80+ level Titanium,  
Dimensions (W x H x L): 76 x 40 x 336mm  
Total Output Power: 1000W/1800W/1980W/2000W  
Output Type: 27 Pairs Gold Finger Connector

### Input:

1000W: 100-127Vac / 12.5-9.5A / 50-60Hz  
1800W: 200-220Vac / 10-9.5A / 50-60Hz  
1980W: 220-230Vac / 10-9.8A / 50-60Hz  
2000W: 230-240Vac / 10-9.8A / 50-60 Hz  
2000W: 200-240Vac / 11.8-9.8A / 50-60 Hz  
(UL/cUL only)

### +12V

Max.: 83.3A / Min.: 0A (100Vac-127Vac)  
Max.: 150A / Min.: 0A (200Vac-220Vac)  
Max.: 165A / Min.: 0A (220Vac-230Vac)  
Max.: 166.7A / Min.: 0A (230Vac-240Vac)  
Max.: 166.7A / Min.: 0A (200Vac-240Vac)  
(UL/cUL only)

### +5Vsb

Max.: 1A/Min.: 0A

## Operating Environment

Operating Temperature: 10° to 35° C (50° to 95° F)  
Non-operating Temperature: -40° to 70° C (-40° F to 158° F)  
Operating Relative Humidity: 8% to 90% (non-condensing)  
Non-operating Relative Humidity: 5% to 95% (non-condensing)

## Regulatory Compliance

Electromagnetic Emissions: FCC Class A, EN 55032 Class A, EN 61000-3-2/3-3, CISPR 32 Class A  
Electromagnetic Immunity: EN 55024/CISPR 24, (EN 61000-4-2, EN 61000-4-3, EN 61000-4-4, EN 61000-4-5, EN 61000-4-6, EN 61000-4-8, EN 61000-4-11)  
Other: VCCI-CISPR 32 and AS/NZS CISPR 32  
Environmental: Directive 2011/65/EU and Delegated Directive (EU) 2015/863 and Directive 2012/19/EU  
Safety: CSA/EN/IEC/UL 60950-1 Compliant, UL or CSA Listed (USA and Canada), CE Marking (Europe)

## Perchlorate Warning

California Best Management Practices Regulations for Perchlorate Materials: This Perchlorate warning applies only to products containing CR (Manganese Dioxide) Lithium coin cells. "Perchlorate Material-special handling may apply. See [www.dtsc.ca.gov/hazardouswaste/perchlorate](http://www.dtsc.ca.gov/hazardouswaste/perchlorate)"

## Appendix D

### UEFI BIOS Recovery

**Warning:** Do not upgrade the BIOS unless your system has a BIOS-related issue. Flashing the wrong BIOS can cause irreparable damage to the system. In no event shall Supermicro be liable for direct, indirect, special, incidental, or consequential damages arising from a BIOS update. If you do update the BIOS, do not shut down or reset the system while the BIOS is updating to avoid possible boot failure.

#### D.1 Overview

The Unified Extensible Firmware Interface (UEFI) provides a software-based interface between the operating system and the platform firmware in the pre-boot environment. The UEFI specification supports an architecture-independent mechanism that will allow the UEFI OS loader stored in an add-on card to boot the system. The UEFI offers clean, hands-off management to a computer during system boot.

#### D.2 Recovering the UEFI BIOS Image

A UEFI BIOS flash chip consists of a recovery BIOS block and a main BIOS block (a main BIOS image). The recovery block contains critical BIOS codes, including memory detection and recovery codes for the user to flash a healthy BIOS image if the original main BIOS image is corrupted. When the system power is turned on, the recovery block codes execute first. Once this process is complete, the main BIOS code will continue with system initialization and the remaining POST (Power-On Self-Test) routines.

**Note 1:** Follow the BIOS recovery instructions below for BIOS recovery when the main BIOS block crashes.

**Note 2:** When the BIOS recovery block crashes, you will need to follow the procedures to make a Returned Merchandise Authorization (RMA) request. (For a RMA request, please see section 1.7 for more information). Also, you may use the Supermicro Update Manager (SUM) Out-of-Band (OOB) ([https://www.supermicro.com.tw/products/nfo/SMS\\_SUM.cfm](https://www.supermicro.com.tw/products/nfo/SMS_SUM.cfm)) to reflash the BIOS.

#### D.3 Recovering the Main BIOS Block with a USB Device

This feature allows the user to recover the main BIOS image using a USB-attached device without additional utilities used. A USB flash device such as a USB Flash Drive, or a USB CD/DVD ROM/RW device can be used for this purpose. However, a USB Hard Disk drive cannot be used for BIOS recovery at this time.

The file system supported by the recovery block is FAT (including FAT12, FAT16, and FAT32) which is installed on a bootable or non-bootable USB-attached device. However, the BIOS might need several minutes to locate the SUPER.ROM file if the media size becomes too large due to the huge volumes of folders and files stored in the device.

To perform UEFI BIOS recovery using a USB-attached device, follow the instructions below.

1. Using a different machine, copy the "Super.ROM" binary image file into the Root "\" directory of a USB device or a writable CD/DVD.

**Note 1:** If you cannot locate the "Super.ROM" file in your drive disk, visit our website at [www.supermicro.com](http://www.supermicro.com) to download the BIOS package. Extract the BIOS binary image into a USB flash device and rename it "Super.ROM" for the BIOS recovery use.

**Note 2:** Before recovering the main BIOS image, confirm that the "Super.ROM" binary image file you download is the same version or a close version meant for your motherboard.

2. Insert the USB device that contains the new BIOS image ("Super.ROM") into your USB drive and reset the system when the following screen appears.



3. After locating the healthy BIOS binary image, the system will enter the BIOS Recovery menu as shown below.

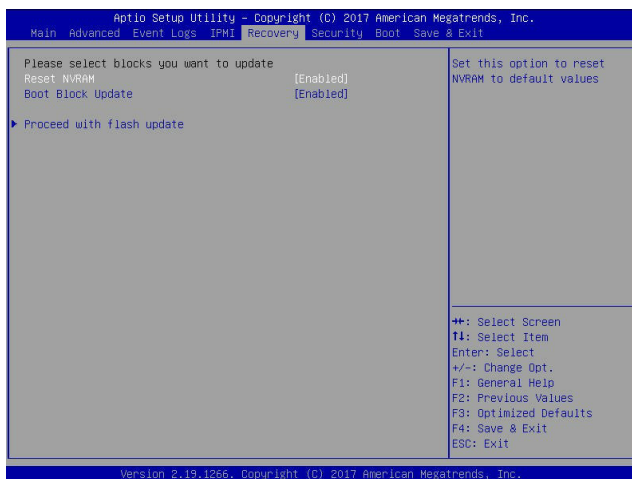

**Note:** At this point, you may decide if you want to start the BIOS recovery. If you decide to proceed with BIOS recovery, follow the procedures below.

4. When the screen as shown above displays, use the arrow keys to select the item "Proceed with flash update" and press the <Enter> key. You will see the BIOS recovery progress as shown in the screen below.

**Note:** Do not interrupt the BIOS flashing process until it has completed.

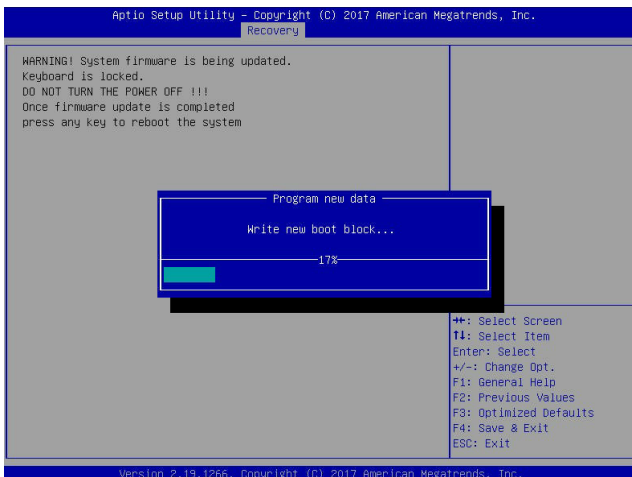

5. After the BIOS recovery process is complete, press any key to reboot the system.

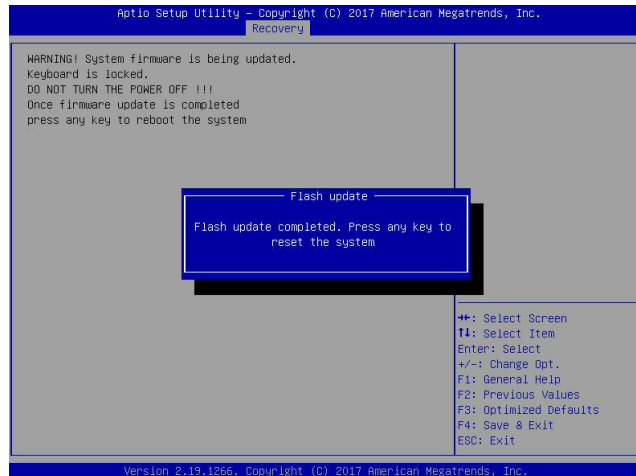

6. Using a different system, extract the BIOS package into a USB flash drive.
7. Press <Del> continuously during system boot to enter the BIOS Setup utility. From the top of the tool bar, select Boot to enter the submenu. From the submenu list, select Boot Option #1 as shown below. Then, set Boot Option #1 to [UEFI AP:UEFI: Built-in EFI Shell]. Press <F4> to save the settings and exit the BIOS Setup utility.

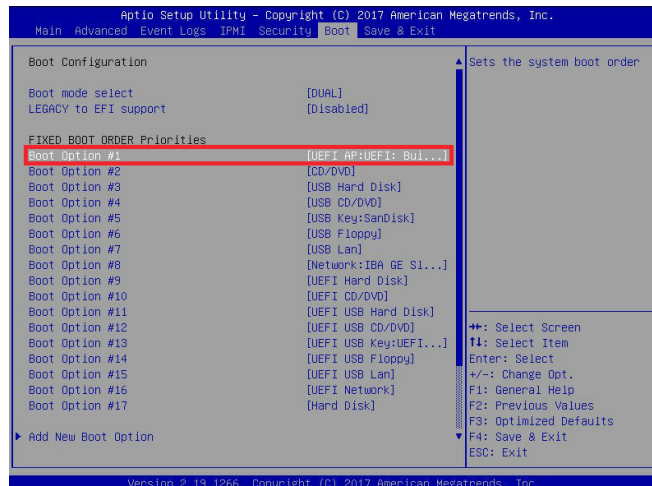

8. When the UEFI Shell prompt appears, type `fs#` to change the device directory path. Go to the directory that contains the BIOS package you extracted earlier from Step 6. Enter `flash.nsh BIOSname.###` at the prompt to start the BIOS update process.

```

UEFI Interactive Shell v2.1
EDK II
UEFI v2.50 (American Megatrends, 0x0005000C)
Mapping Table
FS0: Alias(s):HD0:0B:BLK1:
      PciRoot(0x0)/Pci(0x14,0x0)/USB(0x11,0x0)/HD(1,MBR,0x3791072,0x800,0x1
CR9592)
      BLK0: Alias(s):
      PciRoot(0x0)/Pci(0x14,0x0)/USB(0x11,0x0)
Press F8 in 1 seconds to skip startup.nsh or any other key to continue.
Shell> fs0:
FS0:\> cd AFUDOS
FS0:\AFUDOS> cd SHIPME2_03162017
FS0:\AFUDOS\SHIPME2_03162017> flash.nsh X110PU7_314

```

**Note:** *Do not interrupt this process* until the BIOS flashing is complete.

```

Done.
[ Access Cmos Port Ex ]
<Read>
Index 0x51: 0x10

Done.
*****
* Program BIOS and ME (including FDT) regions...
*****
| AMT Firmware Update Utility v5.09.01.1917
| Copyright (C)2017 American Megatrends Inc. All Rights Reserved.
|-----|
CPUID = 50652

Reading flash ..... done
- ME Data Size checking - ok
- FFS checksums ..... ok
- Check RomLayout ..... Ok
Erasing Boot Block ..... done
Updating Boot Block ..... done
Verifying Boot Block ..... done
_Erasing Main Block ..... 0x00132000 (0x)

```

9. The screen above indicates that the BIOS update process is complete. When you see the screen above, unplug the AC power cable from the power supply, clear CMOS, and plug the AC power cable in the power supply again to power on the system.

```

Verifying NDB Block ..... done
- Update success for FDR
- Update success for IE
- Successful Update Recovery Loader to OPRx11
- Successful Update MFSB11
- Successful Update FPR11
- Successful Update MFS, IVB1 and IVB211
- Successful Update FLOG and UTDK11
- ME Entire Image update success !!
WARNING : System must power-off to have the changes take effect!
Moving FS0:\AFUDOS\SHIPME2_03162017\Fdtv64.efi -> FS0:\AFUDOS\SHIPME2_03162017\F
dt1.smc
- [ok]
Moving FS0:\AFUDOS\SHIPME2_03162017\Fuef1x64.efi -> FS0:\AFUDOS\SHIPME2_0316201
7\Fuef1.smc
- [ok]
*****
* Please ignore this 'Shell: Cannot read from file - Device Error'
* warning message due to it does not impact flashing process.
*****
Deleting " "
Delete successful.
FS0:\>

```

10. Press `<Del>` continuously to enter the BIOS Setup utility.
11. Press `<F3>` to load the default settings.
12. After loading the default settings, press `<F4>` to save the settings and exit the BIOS Setup utility.

## Appendix E

### IPMI Crash Dump

In the event of a processor internal error (IERR) that crashes your system, you may want to provide information to support staff. You can download a crash dump of status information using IPMI. The IPMI manual is available at <https://www.supermicro.com/solutions/IPMI.cfm>.

#### Check IPMI Error Log

1. Access the IPMI web interface.
2. Click the **Server Health** tab, then **Event Log** to verify an IERR error.

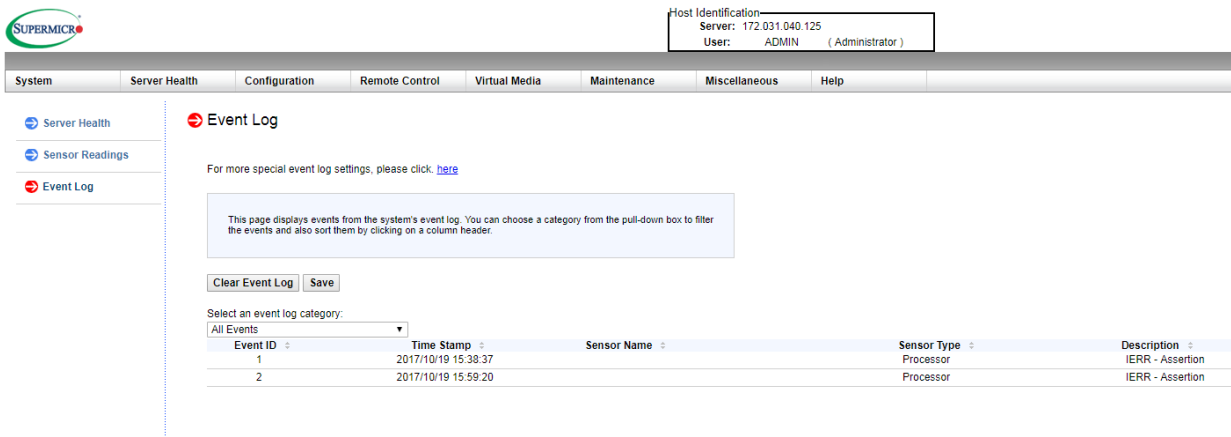

The screenshot shows the IPMI web interface. At the top right, there is a 'Host Identification' box containing 'Server: 172.031.040.125' and 'User: ADMIN (Administrator)'. Below this is a navigation menu with tabs: System, Server Health, Configuration, Remote Control, Virtual Media, Maintenance, Miscellaneous, and Help. The 'Server Health' tab is active, and the 'Event Log' sub-tab is selected. On the left, there is a sidebar with links for 'Server Health', 'Sensor Readings', and 'Event Log'. The main content area displays the 'Event Log' page. It includes a message: 'For more special event log settings, please click: [here](#)'. Below this is a text box explaining that the page displays events from the system's event log and that users can filter events by category and sort them by clicking on a column header. There are 'Clear Event Log' and 'Save' buttons. A dropdown menu is set to 'All Events'. Below the dropdown is a table with the following data:

Event ID	Time Stamp	Sensor Name	Sensor Type	Description
1	2017/10/19 15:38:37		Processor	IERR - Assertion
2	2017/10/19 15:59:20		Processor	IERR - Assertion

Figure E-1. IPMI Event Log

In the event of an IERR, the BMC executes a crash dump. You must download the crash dump and save it.

### Downloading the Crash Dump File

1. In the IPMI interface, click the **Miscellaneous** tab, then the **Trouble Shooting** option.
2. Click the **Dump** button and wait five minutes for the file to be created. (No confirmation message will appear.)
3. Click the **Download** button and a Save As dialog appears.
4. Save the zipped dump file, noting the name and location.

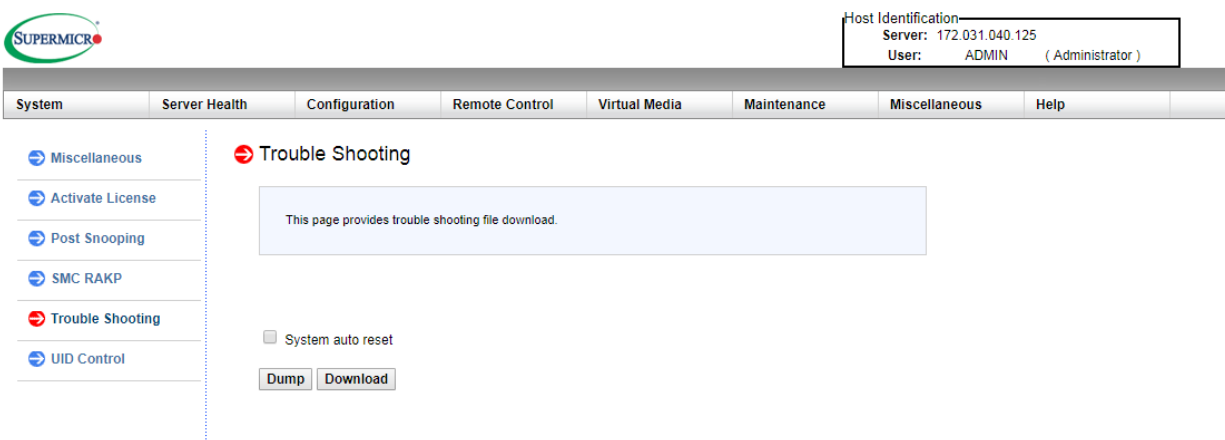

Figure E-2. IPMI Crash Dump Download

**Note:** The **System auto reset** check box dictates behavior after an IERR. If checked, the system will restart automatically, and the dump file will be erased. If not, the system remains in a failed state. Do not check this box until after the dump file has been sent to Support.