

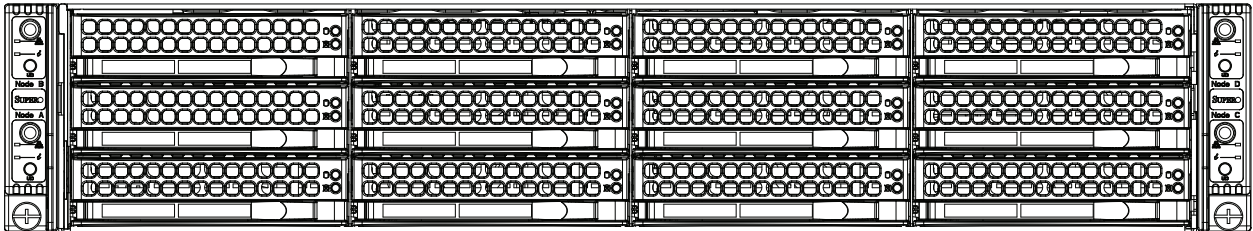

# A+ Server<sup>®</sup> AS -2014TP-HTR



USER'S MANUAL

Revision 1.0

The information in this User's Manual has been carefully reviewed and is believed to be accurate. The vendor assumes no responsibility for any inaccuracies that may be contained in this document, and makes no commitment to update or to keep current the information in this manual, or to notify any person or organization of the updates. Please Note: For the most up-to-date version of this manual, please see our website at [www.supermicro.com](http://www.supermicro.com).

Super Micro Computer, Inc. ("Supermicro") reserves the right to make changes to the product described in this manual at any time and without notice. This product, including software and documentation, is the property of Supermicro and/or its licensors, and is supplied only under a license. Any use or reproduction of this product is not allowed, except as expressly permitted by the terms of said license.

IN NO EVENT WILL Super Micro Computer, Inc. BE LIABLE FOR DIRECT, INDIRECT, SPECIAL, INCIDENTAL, SPECULATIVE OR CONSEQUENTIAL DAMAGES ARISING FROM THE USE OR INABILITY TO USE THIS PRODUCT OR DOCUMENTATION, EVEN IF ADVISED OF THE POSSIBILITY OF SUCH DAMAGES. IN PARTICULAR, SUPER MICRO COMPUTER, INC. SHALL NOT HAVE LIABILITY FOR ANY HARDWARE, SOFTWARE, OR DATA STORED OR USED WITH THE PRODUCT, INCLUDING THE COSTS OF REPAIRING, REPLACING, INTEGRATING, INSTALLING OR RECOVERING SUCH HARDWARE, SOFTWARE, OR DATA.

Any disputes arising between manufacturer and customer shall be governed by the laws of Santa Clara County in the State of California, USA. The State of California, County of Santa Clara shall be the exclusive venue for the resolution of any such disputes. Supermicro's total liability for all claims will not exceed the price paid for the hardware product.

FCC Statement: This equipment has been tested and found to comply with the limits for a Class A digital device pursuant to Part 15 of the FCC Rules. These limits are designed to provide reasonable protection against harmful interference when the equipment is operated in a commercial environment. This equipment generates, uses, and can radiate radio frequency energy and, if not installed and used in accordance with the manufacturer's instruction manual, may cause harmful interference with radio communications. Operation of this equipment in a residential area is likely to cause harmful interference, in which case you will be required to correct the interference at your own expense.

California Best Management Practices Regulations for Perchlorate Materials: This Perchlorate warning applies only to products containing CR (Manganese Dioxide) Lithium coin cells. "Perchlorate Material-special handling may apply. See [www.dtsc.ca.gov/hazardouswaste/perchlorate](http://www.dtsc.ca.gov/hazardouswaste/perchlorate)".



WARNING: This product can expose you to chemicals including lead, known to the State of California to cause cancer and birth defects or other reproductive harm. For more information, go to [www.P65Warnings.ca.gov](http://www.P65Warnings.ca.gov).

The products sold by Supermicro are not intended for and will not be used in life support systems, medical equipment, nuclear facilities or systems, aircraft, aircraft devices, aircraft/emergency communication devices or other critical systems whose failure to perform be reasonably expected to result in significant injury or loss of life or catastrophic property damage. Accordingly, Supermicro disclaims any and all liability, and should buyer use or sell such products for use in such ultra-hazardous applications, it does so entirely at its own risk. Furthermore, buyer agrees to fully indemnify, defend and hold Supermicro harmless for and against any and all claims, demands, actions, litigation, and proceedings of any kind arising out of or related to such ultra-hazardous use or sale.

Manual Revision 1.0

Release Date: November 13, 2019

Unless you request and receive written permission from Super Micro Computer, Inc., you may not copy any part of this document. Information in this document is subject to change without notice. Other products and companies referred to herein are trademarks or registered trademarks of their respective companies or mark holders.

# Preface

## About this Manual

This manual is written for professional system integrators and PC technicians. It provides information for the installation and use of the A+ Server AS -2014TP-HTR. Installation and maintenance should be performed by experienced technicians only.

## Notes

For your system to work properly, please follow the links below to download all necessary drivers, utilities and the user's manual for your server.

- Supermicro product manuals: <http://www.supermicro.com/support/manuals/>
- Product drivers and utilities: <https://www.supermicro.com/wftp/driver>
- Product safety info: [http://www.supermicro.com/about/policies/safety\\_information.cfm](http://www.supermicro.com/about/policies/safety_information.cfm)

If you have any questions, please contact our support team at: [support@supermicro.com](mailto:support@supermicro.com)

This manual may be periodically updated without notice. Please check the Supermicro website (<http://www.supermicro.com>) for possible updates to the manual revision level.

## Warnings

Special attention should be given to the following symbols used in this manual.



**Warning!** Indicates important information given to prevent equipment/property damage or personal injury.



**Warning!** Indicates high voltage may be encountered when performing a procedure.

# Contents

## **Chapter 1 Introduction**

1.1 Overview.....	8
1.2 Unpacking the System .....	8
1.3 System Features .....	9
1.4 2U Twin2: System Notes.....	10
Nodes .....	10
System Power .....	10
Hard Drive Backplane/Drives .....	10
1.5 Server Chassis Features.....	11
Control Panel .....	11
Front Features.....	13
Rear Features .....	14
1.6 Motherboard Layout .....	15
Quick Reference Table.....	16

## **Chapter 2 Server Installation**

2.1 Overview.....	18
2.2 Preparing for Setup.....	18
Choosing a Setup Location.....	18
Rack Precautions .....	18
Server Precautions.....	19
Rack Mounting Considerations .....	19
Ambient Operating Temperature.....	19
Airflow .....	19
Mechanical Loading.....	19
Circuit Overloading .....	20
Reliable Ground.....	20
2.3 Installing the Rails .....	21
Identifying the Rails.....	21
Locking Tabs .....	22
Releasing the Inner Rail.....	22
Installing the Chassis Rails .....	23
Installing the Outer Rails on the Rack .....	24
Standard Chassis Installation.....	25

---

---

**Chapter 3 Maintenance and Component Installation**

3.1 Removing Power .....	26
3.2 Accessing the System .....	26
3.3 Motherboard Components .....	28
Processor and Heatsink Installation .....	28
Installing the Processor and Heatsink .....	29
Memory Support and Installation .....	36
Memory Support .....	36
DIMM Module Population .....	37
DIMM Installation .....	38
DIMM Removal .....	38
PCI Expansion Card Installation .....	39
Motherboard Battery .....	40
3.4 Chassis Components .....	41
Hard Drives .....	41
Hard Drive Carrier Indicators .....	44
System Cooling .....	45
Optional Fan Configurations .....	45
Installing Fans .....	45
Air Shroud .....	48
Adapter Card Replacement .....	49
SIOM Modules .....	51
Power Supply .....	55
Power Supply Replacement .....	55

**Chapter 4 Motherboard Connections**

4.1 Headers and Connectors .....	56
4.2 Ports .....	59
4.3 Jumpers .....	61
Explanation of Jumpers .....	61
4.4 LED Indicators .....	63
4.5 PCI-E 4.0 Slots .....	65

**Chapter 5 Software**

5.1 Microsoft Windows OS Installation.....66  
5.2 Driver Installation.....68  
5.3 SuperDoctor® 5.....69  
5.4 IPMI .....69

**Chapter 6 UEFI BIOS**

6.1 Introduction.....70  
    Starting the Setup Utility .....70  
6.2 Main Setup .....71  
6.3 Advanced.....73  
6.4 IPMI .....88  
6.5 Event Logs .....91  
6.6 Security.....93  
6.7 Boot .....94  
6.8 Save & Exit.....96

**Appendix A UEFI BIOS Recovery**

**Appendix B Standardized Warning Statements for AC Systems**

**Appendix C System Specifications**

## Contacting Supermicro

### Headquarters

Address: Super Micro Computer, Inc.  
980 Rock Ave.  
San Jose, CA 95131 U.S.A.

Tel: +1 (408) 503-8000

Fax: +1 (408) 503-8008

Email: [marketing@supermicro.com](mailto:marketing@supermicro.com) (General Information)  
[support@supermicro.com](mailto:support@supermicro.com) (Technical Support)

Website: [www.supermicro.com](http://www.supermicro.com)

### Europe

Address: Super Micro Computer B.V.  
Het Sterrenbeeld 28, 5215 ML  
's-Hertogenbosch, The Netherlands

Tel: +31 (0) 73-6400390

Fax: +31 (0) 73-6416525

Email: [sales@supermicro.nl](mailto:sales@supermicro.nl) (General Information)  
[support@supermicro.nl](mailto:support@supermicro.nl) (Technical Support)  
[rma@supermicro.nl](mailto:rma@supermicro.nl) (Customer Support)

Website: [www.supermicro.nl](http://www.supermicro.nl)

### Asia-Pacific

Address: Super Micro Computer, Inc.  
3F, No. 150, Jian 1st Rd.  
Zhonghe Dist., New Taipei City 235  
Taiwan (R.O.C)

Tel: +886-(2) 8226-3990

Fax: +886-(2) 8226-3992

Email: [support@supermicro.com.tw](mailto:support@supermicro.com.tw)

Website: [www.supermicro.com.tw](http://www.supermicro.com.tw)

# Chapter 1

## Introduction

### 1.1 Overview

This chapter provides a brief outline of the functions and features of the AS -2014TP-HTR. The AS -2014TP-HTR is based on the H12SST-PS motherboard and the SC827HQ+-R2K04BP2 chassis.

In addition to the motherboards and chassis, several important parts that are included with the system are listed below.

Main Parts List		
Description	Part Number	Quantity
Passive CPU heatsink	SNK-P0062P	4
Air shrouds	MCP-310-82723-0B	4
8-cm cooling fans	FAN-0162L4	4
Backplane adapter cards	BPN-ADP-6SATA3P	4
SAS backplane HDD	BPN-SAS3-827HQ2	1
Hot-swap 3.5" HDD trays	MCP-220-00075-0B	12
1U Right Hand Side riser cards	RSC-PR-6-X2	4
1U Left Hand Side riser cards	RSC-P-6-X2	4
Rackmount rail kit	MCP-290-00053-0N	1
2000W Titanium Level redundant power supply	PWS-2K04A-1R	2

### 1.2 Unpacking the System

Inspect the box the A+ Server AS -2014TP-HTR was shipped in and note if it was damaged in any way. If any equipment appears damaged, please file a damage claim with the carrier who delivered it.

Decide on a suitable location for the rack unit that will hold the server. It should be situated in a clean, dust-free area that is well ventilated. Avoid areas where heat, electrical noise and electromagnetic fields are generated. It will also require a grounded AC power outlet nearby. Be sure to read the precautions and considerations noted in Appendix B.



## 1.3 System Features

The following table provides you with an overview of the main features of the AS -2014TP-HTR. Please refer to Appendix C for additional specifications.

<b>System Features</b>
<b>Motherboard (per node)</b>
One H12SST-PS
<b>Chassis</b>
SC827HQ+-R2K04BP2
<b>CPU (per node)</b>
One AMD EPYC® 7002 System on Chip processor
<b>Socket Type</b>
AMD Socket SP3
<b>Memory (per node)</b>
Supports up to 2TB of ECC DDR4 3200 MHz speed, RDIMM/LRDIMM/3DS/NVDIMM memory in eight slots
<b>Expansion Slots (per node)</b>
Two PCI-E 4.0 x16 low profile (6.6" long) slots
<b>Storage (per node)</b>
Four hybrid M.2 slots in the 2280 and 22110 form factors Three hot-swap 3.5" SATA drive bays
<b>Networking (per node)</b>
One PCI-E 4.0 x16 + x1 SIOM networking slot
<b>Input/Output (per node)</b>
Two rear USB 3.0 ports, one dedicated IPMI LAN port, one VGA port
<b>Power</b>
Two 2000W High-efficiency Titanium Level redundant power supplies
<b>System Cooling</b>
Four heavy duty mid-chassis fans with optimal fan speed control
<b>Dimensions</b>
(WxHxD) 17.25 x 3.47 x 28.5 in. (438 x 88 x 724 mm)

## 1.4 2U Twin2: System Notes

As a 2U Twin<sup>2</sup> configuration, the A+ Server AS -2014TP-HTR is a unique server system. With four system boards incorporated into a single chassis acting as four separate nodes, there are several points you should keep in mind.

### Nodes

Each of the four serverboards act as a separate node in the system. As independent nodes, each may be powered off and on without affecting the others. In addition, each node is a hot-swappable unit that may be removed from the rear of the chassis. The nodes are connected to the server backplane by means of an adapter card.

**Note:** A guide pin is located between the upper and lower nodes on the inner chassis wall. This guide pin also acts as a “stop” when a node is fully installed. If too much force is used when inserting a node this pin may break off. Take care to slowly slide a node in until you hear the “click” of the locking tab seating itself.

### System Power

Dual 2000 Watt power supplies are used to provide the power for all four serverboards. Each serverboard however, can be shut down independently of the other with the power button on its own control panel.

### Hard Drive Backplane/Drives

As a system, the A+ Server AS -2014TP-HTR supports the use of 12 SATA hard drives. A single backplane works to apply system-based control for power and fan speed functions, yet at the same time logically connects a set of three hard drives to each of the four nodes. See the Hard Drives section in Section 3.4 for the logical hard drive and node configuration.

## 1.5 Server Chassis Features

### Control Panel

The SC827HQ+-R2K04BP2 chassis includes four front panels on the handles of the chassis which control each of the nodes. Each control panel on the A+ Server AS -2014TP-HTR provides you with system monitoring and control for one server node. LEDs indicate system power, HDD activity, network activity, system overhear and power supply failure. A main power button and a UID button are also included.

The switches and LEDs located on the control panel are described below. See Chapter 4 for details on the control panel connections.

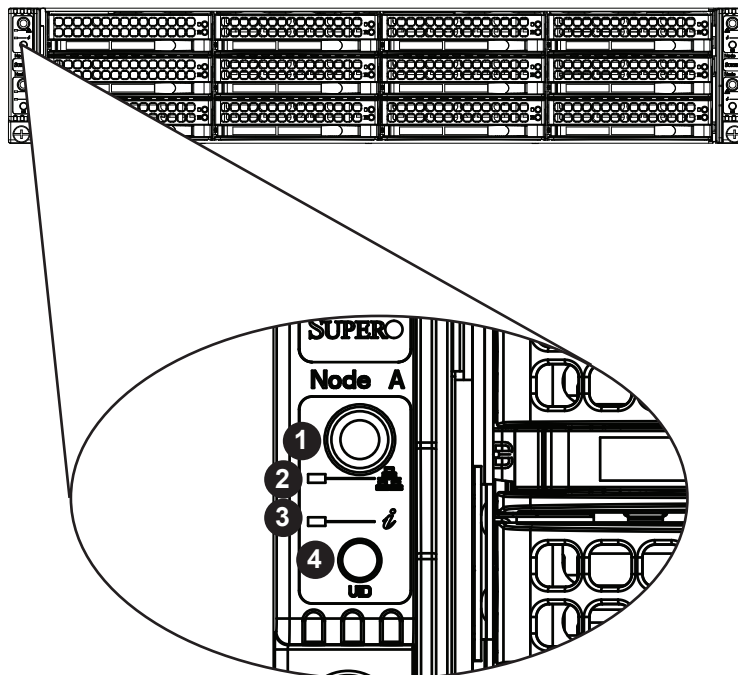

Figure 1-1. Control Panel View

<b>Control Panel Features</b>		
<b>Item</b>	<b>Feature</b>	<b>Description</b>
1	Power Button	The main power button on each of the control panels is used to apply or remove power from the power supply to the associated node. Turning power to the system off with this button removes the main power, but keeps standby power supplied to the system. The power button has a built-in LED which will turn green when the power is on.
2	NIC1 LED	This LED indicates network activity on either LAN1 or LAN2 when flashing.
3	Information LED	See the following table for the status shown by this LED.
4	UID Button	The UID button is used to turn on or off the blue light function of the LED. This light is displayed in the front as part of the UID button and with a separate LED at the rear of the node. The light helps locate the node in large racks and server banks.

<b>Information LED</b>	
<b>Status</b>	<b>Description</b>
Continuously on and red	An overheat condition has occurred. (This may be caused by cable congestion.)
Blinking red (1 Hz)	Fan failure: check for an inoperative fan.
Blinking red (0.25 Hz)	Power failure: check for an inoperative power supply.
Solid blue	Local UID has been activated. Use this function to locate the server in a rack environment.
Blinking blue (300 Msec)	Remote UID has been activated. Use this function to locate the server from a remote location.

### Front Features

The SC827HQ+-R2K04BP2 is a 2U chassis. See the illustration below for the features included on the front of the chassis.

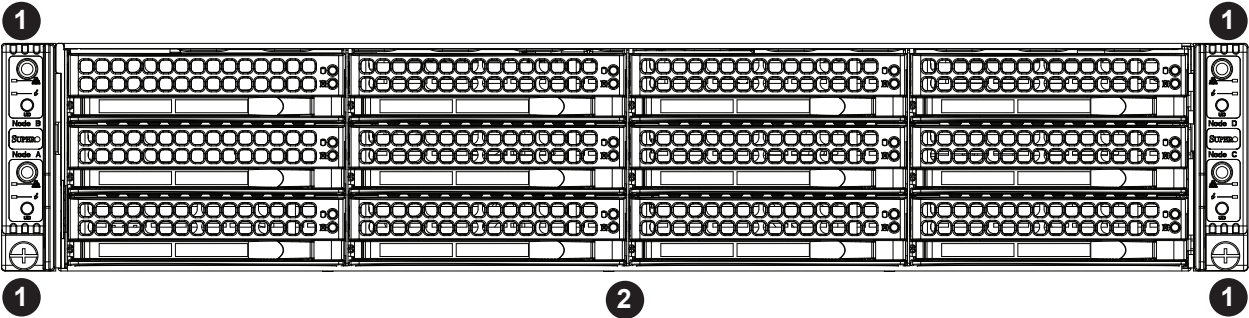

Figure 1-2. Chassis Front View

Front Chassis Features		
Item	Feature	Description
1	Control Panels (per node)	Four control panels are provided on the chassis front for each node in the system.
2	Drive Bays	Twelve drive bays for 3.5" drives are provided on the chassis front, three for each node.

## Rear Features

The illustration below shows the features included on the rear of the chassis.

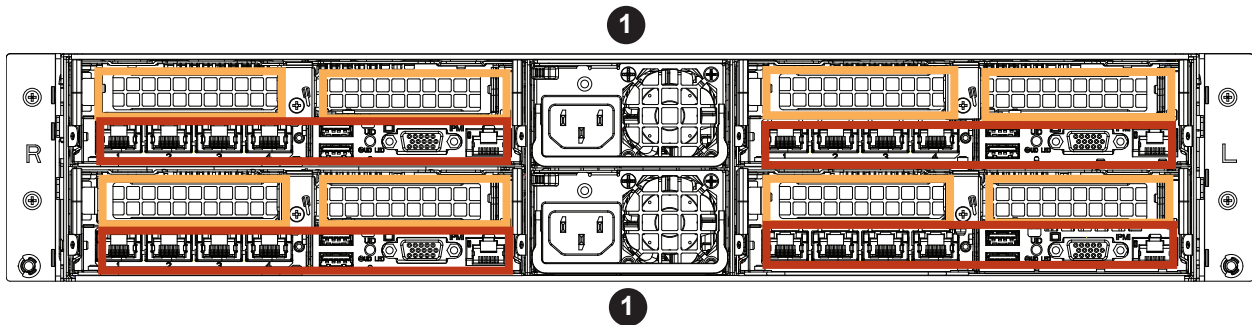

Figure 1-3. Chassis Rear View

Rear Chassis Features		
Item	Feature	Description
1	Power Supplies	Two redundant power supplies are accessible through the rear of the chassis.
2	I/O Ports	Rear I/O ports for each node are accessible on the chassis rear (outlined in red).
3	PCI-E Expansion Card Slots	PCI-E expansion cards can be accessed through these chassis slots (outlined in orange).

## 1.6 Motherboard Layout

Below is a layout of the H12SST-PS with jumper, connector and LED locations shown. See the table on the following page for descriptions. For detailed descriptions, pinout information and jumper settings, refer to Chapter 4.

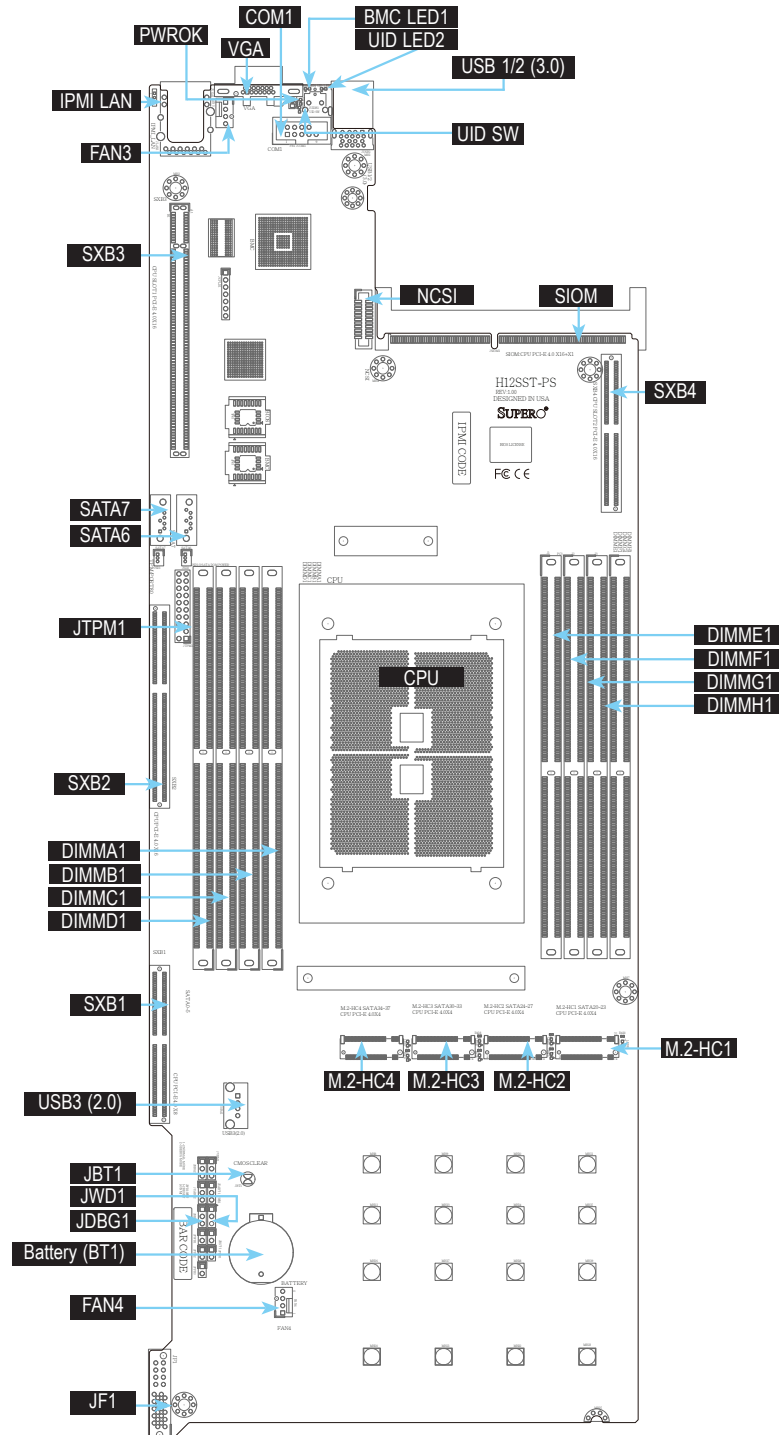

Figure 1-4. Motherboard Layout

## Quick Reference Table

Jumper	Description	Default Setting
UID SW	Unit ID switch (push-button toggles switch ON/OFF)	Off
JBT1	Clear CMOS	Open (Normal)
JDBG1	Debug Mode control	Pins 1-2: Normal mode
JWD1	Watch Dog control	Pins 1-2: Reset

LED	Description	Status
UID LED2	Rear unit ID LED	Solid blue: UID switched to ON, unit identified
BMC LED1	BMC Heartbeat LED	Green: Blinking (BMC normal), Green: Fast blinking (BMC initializing)
PWROK	Power OK LED	Green: System power OK

Connector	Description
Battery (BT1)	Onboard CMOS battery
COM 1	Front panel COM port 1
FAN 3/4	System fan headers
IPMI_LAN	Dedicated IPMI LAN port
JF1	Front control panel
JTPM1	Trusted Platform Module (TPM)/Port 80 connector
SIOM	PCI-E 4.0 x16 + x1 slot for proprietary add-on module
SXB1	PCI-E 4.0 x8 slot and SATA 0~5
SXB2	PCI-E 4.0 x16 slot
SXB3	PCI-E 4.0 x16 left hand riser slot
SXB4	PCI-E 4.0 x16 right hand riser slot
M.2 HC1-4	M.2 connector PCI-E 4.0 x4 and SATA connection
USB 1/2 (3.0)	Back panel USB 3.0 ports
USB 3 (2.0)	Internal USB 2.0 port
VGA	Back panel VGA port
NCSI	NCSI header

**Note:** Jumpers, connectors, switches, and LED indicators that are not described in the preceding table are for manufacturing testing purposes only, and are not covered in this manual.



## H12SST-PS AMD SP3

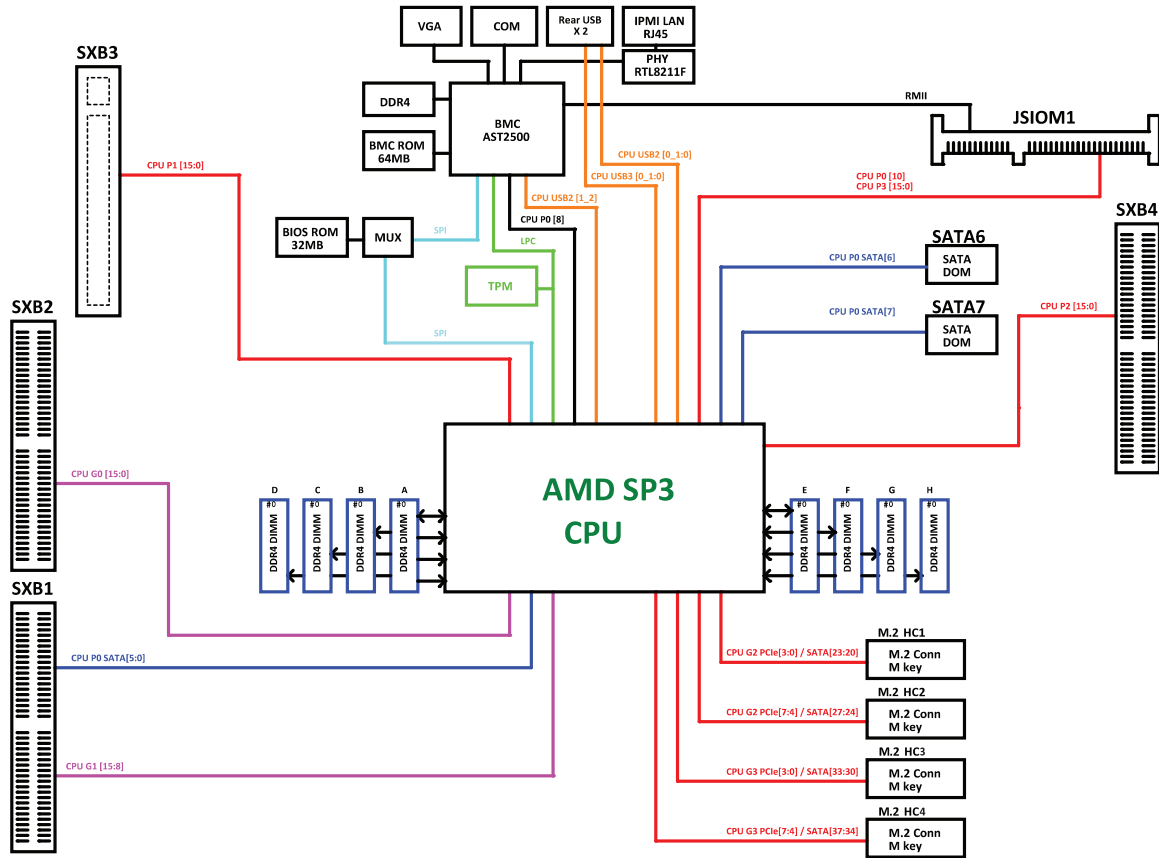

**Figure 1-5. System Block Diagram**

**Note:** This is a general block diagram and may not exactly represent the features on your motherboard. See the System Specifications appendix for the actual specifications of your motherboard.

# Chapter 2

## Server Installation

### 2.1 Overview

This chapter provides advice and instructions for mounting your system in a server rack. If your system is not already fully integrated with processors, system memory etc., refer to Chapter 3 for details on installing those specific components.

**Caution:** Electrostatic Discharge (ESD) can damage electronic components. To prevent such damage to PCBs (printed circuit boards), it is important to use a grounded wrist strap, handle all PCBs by their edges and keep them in anti-static bags when not in use.

### 2.2 Preparing for Setup

The box in which the system was shipped should include the rackmount hardware needed to install it into the rack. Please read this section in its entirety before you begin the installation.

#### Choosing a Setup Location

- The system should be situated in a clean, dust-free area that is well ventilated. Avoid areas where heat, electrical noise and electromagnetic fields are generated.
- Leave enough clearance in front of the rack so that you can open the front door completely (~25 inches) and approximately 30 inches of clearance in the back of the rack to allow sufficient space for airflow and access when servicing.
- This product should be installed only in a Restricted Access Location (dedicated equipment rooms, service closets, etc.).
- This product is not suitable for use with visual display workplace devices according to §2 of the German Ordinance for Work with Visual Display Units.

#### Rack Precautions

- Ensure that the leveling jacks on the bottom of the rack are extended to the floor so that the full weight of the rack rests on them.

- In single rack installations, stabilizers should be attached to the rack. In multiple rack installations, the racks should be coupled together.
- Always make sure the rack is stable before extending a server or other component from the rack.
- You should extend only one server or component at a time - extending two or more simultaneously may cause the rack to become unstable.

## **Server Precautions**

- Review the electrical and general safety precautions in Appendix B.
- Determine the placement of each component in the rack *before* you install the rails.
- Install the heaviest server components at the bottom of the rack first and then work your way up.
- Use a regulating uninterruptible power supply (UPS) to protect the server from power surges and voltage spikes and to keep your system operating in case of a power failure.
- Allow any drives and power supply modules to cool before touching them.
- When not servicing, always keep the front door of the rack and all covers/panels on the servers closed to maintain proper cooling.

## **Rack Mounting Considerations**

### ***Ambient Operating Temperature***

If installed in a closed or multi-unit rack assembly, the ambient operating temperature of the rack environment may be greater than the room's ambient temperature. Therefore, consideration should be given to installing the equipment in an environment compatible with the manufacturer's maximum rated ambient temperature (TMRA).

### ***Airflow***

Equipment should be mounted into a rack so that the amount of airflow required for safe operation is not compromised.

### ***Mechanical Loading***

Equipment should be mounted into a rack so that a hazardous condition does not arise due to uneven mechanical loading.

### ***Circuit Overloading***

Consideration should be given to the connection of the equipment to the power supply circuitry and the effect that any possible overloading of circuits might have on overcurrent protection and power supply wiring. Appropriate consideration of equipment nameplate ratings should be used when addressing this concern.

### ***Reliable Ground***

A reliable ground must be maintained at all times. To ensure this, the rack itself should be grounded. Particular attention should be given to power supply connections other than the direct connections to the branch circuit (i.e. the use of power strips, etc.).



To prevent bodily injury when mounting or servicing this unit in a rack, you must take special precautions to ensure that the system remains stable. The following guidelines are provided to ensure your safety:

- This unit should be mounted at the bottom of the rack if it is the only unit in the rack.
- When mounting this unit in a partially filled rack, load the rack from the bottom to the top with the heaviest component at the bottom of the rack.
- If the rack is provided with stabilizing devices, install the stabilizers before mounting or servicing the unit in the rack.

## 2.3 Installing the Rails

The chassis package includes two rail assemblies in the rack mounting kit. Each assembly consists of three sections: an inner chassis rail, an outer rail, and a middle (see Figure 2-1). The two rail assemblies are left and right specific.

**Note:** This rail will fit a rack between 26.5" and 36.4" deep.

### Identifying the Rails

Refer to Figure 2-1 to identify the rail sections.

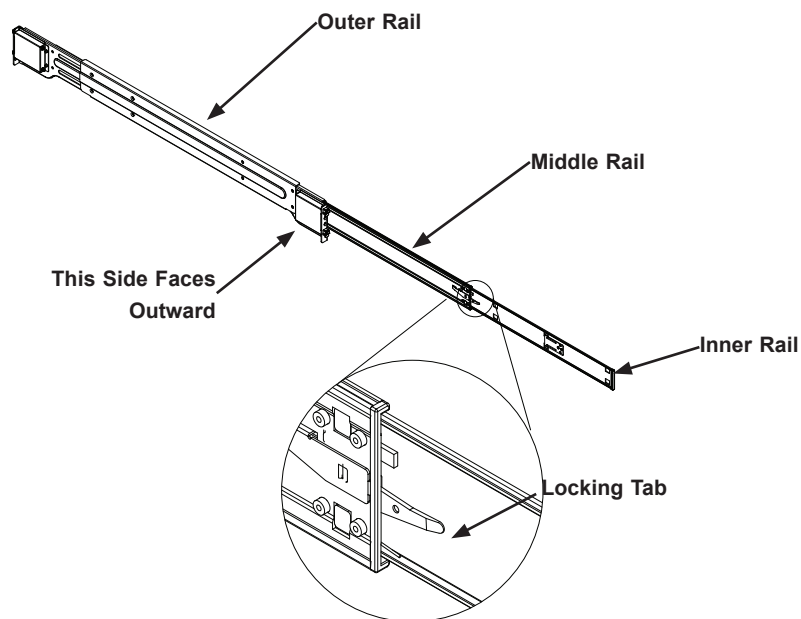

**Figure 2-1. Identifying the Rail Sections**



Slide rail mounted equipment is not to be used as a shelf or a work space.



**Warning:** Do not pick up the server with the front handles. They are designed to pull the system from a rack only.

## Locking Tabs

Each inner rail has a locking tab. This tab locks the chassis into place when installed and pushed fully into the rack. These tabs also lock the chassis in place when fully extended from the rack. This prevents the server from coming completely out of the rack when the chassis is pulled out for servicing.

## Releasing the Inner Rail

Use the procedure below to release the inner rails from the outer rails.

### *Releasing Inner Rail from the Outer Rails*

1. Identify the left and right outer rail assemblies.
2. Pull the inner rail out of the outer rail until it is fully extended as illustrated below.
3. Press the locking tab down to release the inner rail.
4. Pull the inner rail all the way out.
5. Repeat steps 1-3 for the second outer rail.

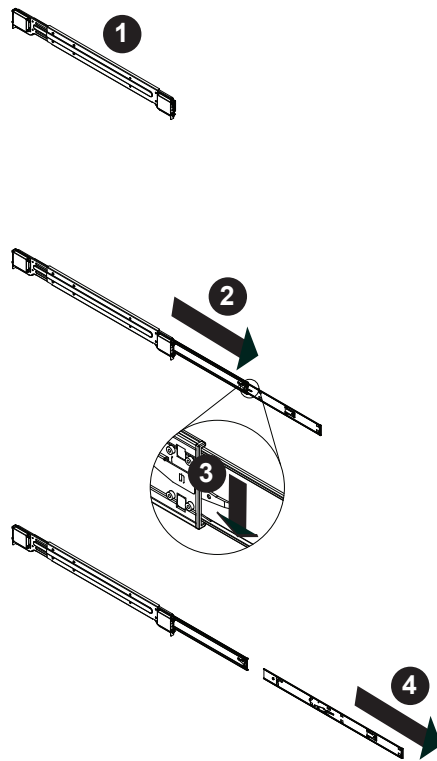

**Figure 2-2. Extending and Releasing the Inner Rail**

## Installing the Chassis Rails

Begin the rack mounting procedure by installing the inner rails to the server chassis.

### *Installing the Inner Rails*

1. Identify the left and right inner rails.
2. Place the inner rail firmly against the side of the chassis, aligning the hooks on the side of the chassis with the holes in the inner rail.
3. Slide the inner rail forward toward the front of the chassis until the rail clicks into the locked position which secures the inner rail to the chassis.
4. Secure the inner rail to the chassis with the screws provided.
5. Repeat steps 1 through 4 above for the other inner rail.

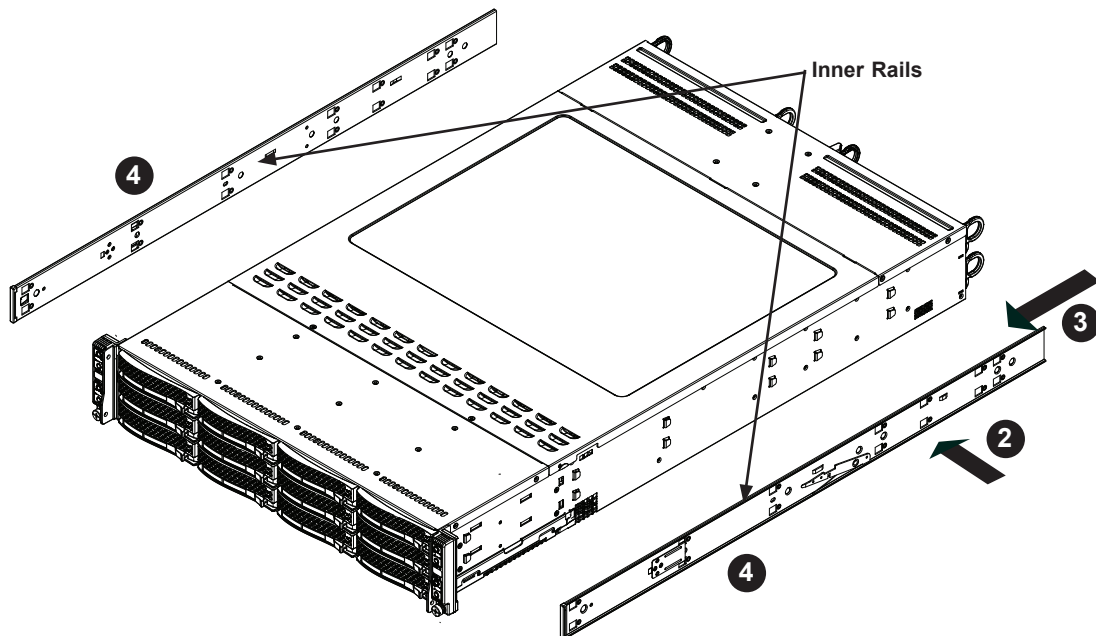

Figure 2-3. Installing the Inner Rails

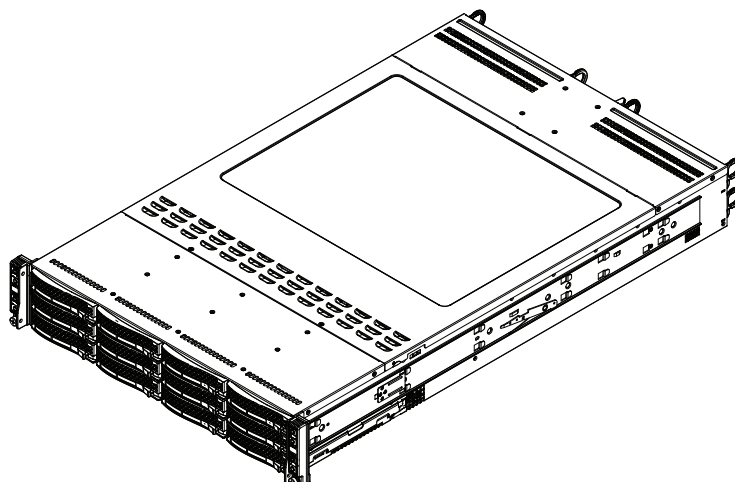

Figure 2-4. Inner Rails Installed on the Chassis

## Installing the Outer Rails on the Rack

Determine where you want to place the server in the rack (see the Rack and Server Precautions in Section 2.2).

Use the procedure below to install the outer rails onto the rack.

### *Installing the Outer Rails*

1. Press upward on the locking tab at the rear end of the middle rail.
2. Push the middle rail back into the outer rail.
3. Hang the hooks of the front of the outer rail onto the slots on the front of the rack. If necessary, use screws to secure the outer rails to the rack, as illustrated above.
4. Pull out the rear of the outer rail, adjusting the length until it fits within the posts of the rack.
5. Hang the hooks of the rear portion of the outer rail onto the slots on the rear of the rack. If necessary, use screws to secure the rear of the outer rail to the rear of the rack.
6. Repeat steps 1-5 for the remaining outer rail.

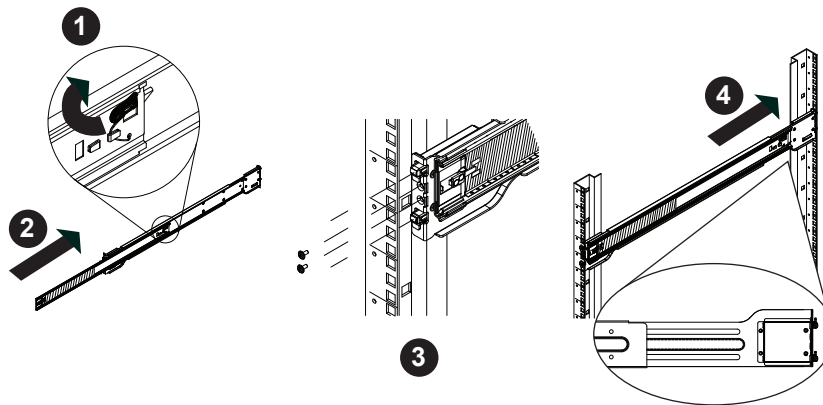

**Figure 2-5. Extending and Releasing the Outer Rails**



**Warning:** Servers should always be installed to the bottom of a rack first for stability reasons.



## Standard Chassis Installation

### *Installing the Chassis into a Rack*

1. Confirm that the inner rails are properly installed on the chassis.
2. Confirm that the outer rails are properly installed on the rack.
3. Pull the middle rail out from the front of the outer rail and make sure that the ball-bearing shuttle is at the front locking position of the middle rail.
4. Align the chassis inner rails with the front of the middle rails.
5. Slide the inner rails on the chassis into the middle rails, keeping the pressure even on both sides, until the locking tab of the inner rail clicks into the front of the middle rail, locking the chassis into the fully extended position.
6. Depress the locking tabs of both sides at the same time and push the chassis all the way into the rear of the rack.
7. If necessary for security purposes, use screws to secure the chassis handles to the front of the rack.

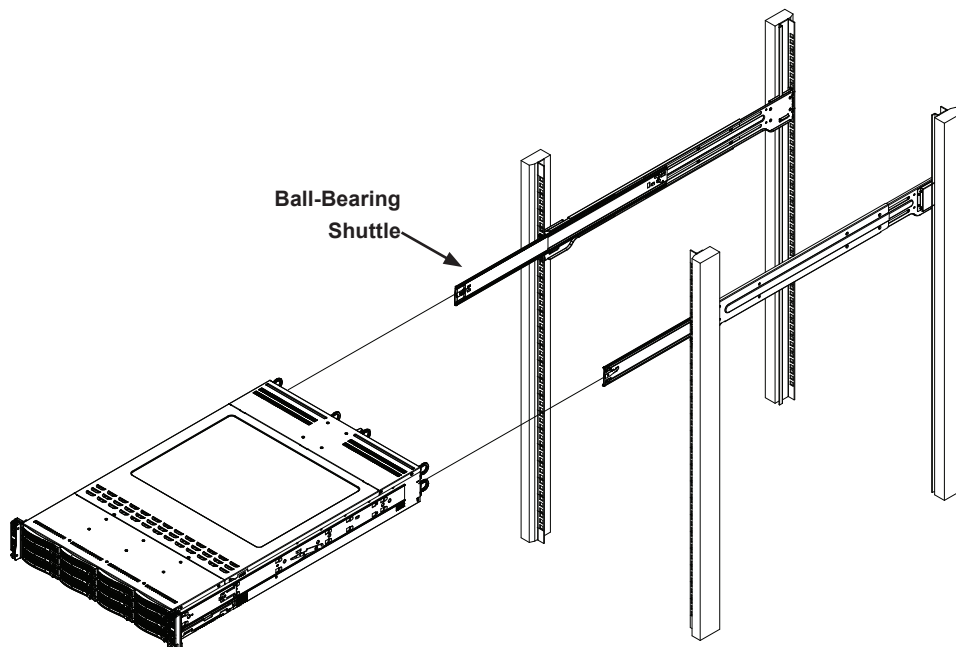

**Figure 2-6. Installing the Server into a Rack**

**Note:** The figure is for illustrative purposes only. Always install servers to the bottom of a rack first.

## Chapter 3

# Maintenance and Component Installation

This chapter provides instructions on installing and replacing main system components. To prevent compatibility issues, only use components that match the specifications and/or part numbers given.

Installation or replacement of most components require that power first be removed from the system. Please follow the procedures given in each section.

### 3.1 Removing Power

Use the following procedure to ensure that power has been removed from the system.

1. Use the operating system to power down the system.
2. After the system has completely shut down, disconnect the AC power cords from the power strip or outlet.
3. Disconnect the power cords from the power supply modules.

### 3.2 Accessing the System

The SC827HQ+-R2K04BP2 features a removable top cover, which allows easy access to the inside of the chassis.

#### ***Removing the Top Cover***

1. Remove the two screws which secure the top cover onto the chassis as shown in Figure 3-1.
2. Lift the top cover up and off the chassis.



**Warning:** Except for short periods of time, do not operate the server without the cover in place. The chassis cover must be in place to allow for proper airflow and to prevent overheating.

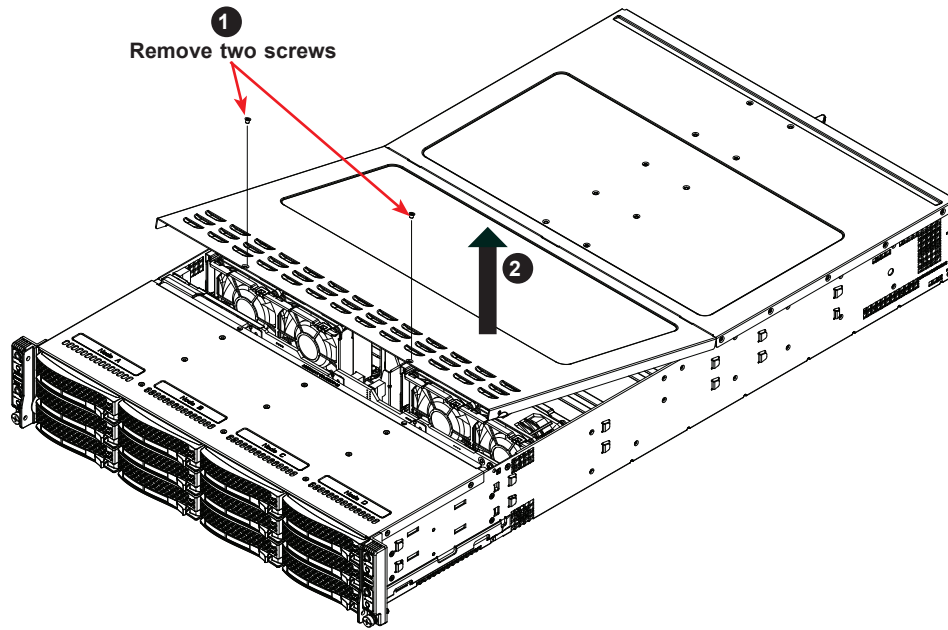

Figure 3-1. Removing the Chassis Cover

## 3.3 Motherboard Components

### Processor and Heatsink Installation

Keep the following in mind:

- For the Processor/Heatsink installation you need to use a T20 screwdriver when opening/closing the CPU socket.
- Always connect the power cords last, and always remove it before adding, removing or changing any hardware components. Make sure that you install the processor into the CPU socket before you install the CPU heatsink.
- If you buy a CPU separately, make sure that you use an Supermicro-certified heatsink only. Make sure to install the motherboard into the chassis before you install the CPU heatsink.
- When receiving a motherboard without a processor pre-installed, make sure that the plastic CPU socket cap is in place and none of the socket pins are bent; otherwise, contact your retailer immediately.
- Refer to the Supermicro website for updates on CPU support.

### ***Installing the Processor and Heatsink***

1. Unscrew the screws holding down the force frame in the sequence of 3-2-1. The screws are numbered on the force frame next to each screw hole.

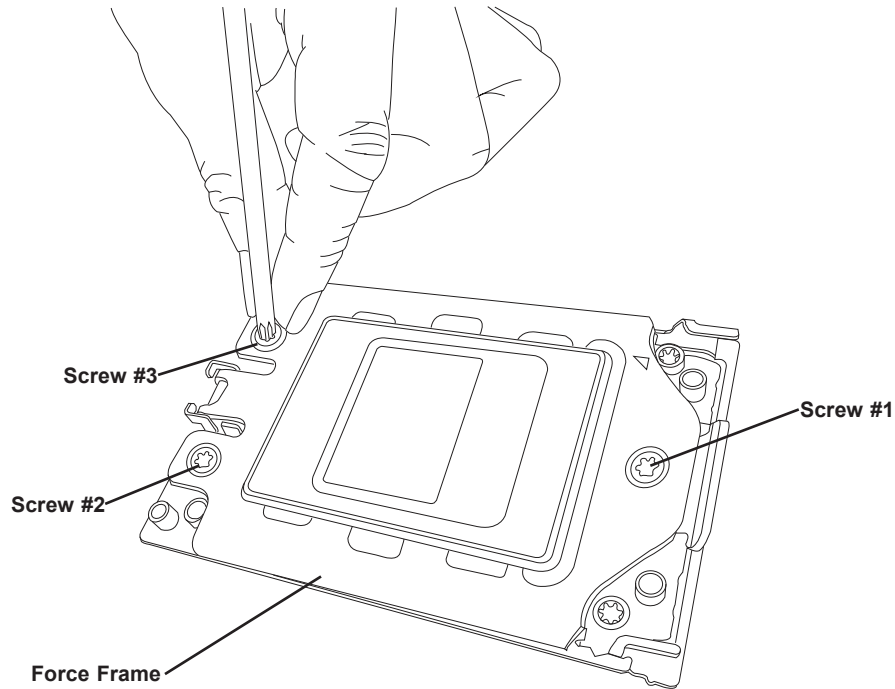

2. The spring-loaded force frame will rise up after the last screw securing it (#1) is removed. Gently allow it to lift up to its stopping position.

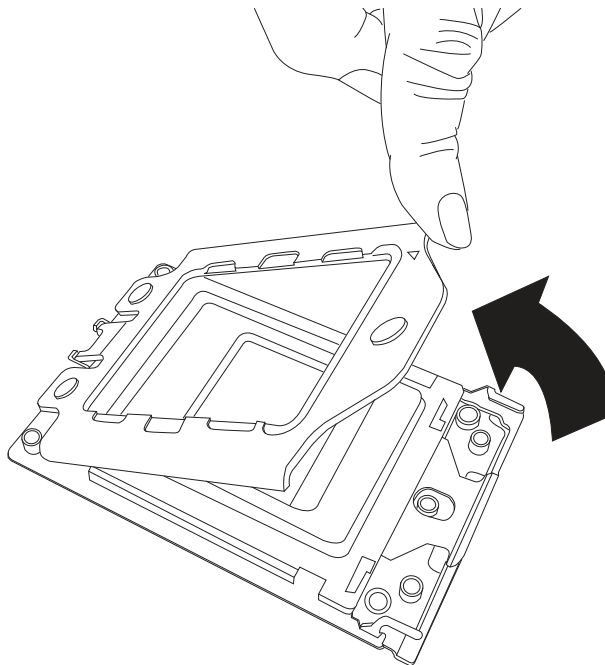

3. Lift the rail frame up by gripping the lift tabs near the front end of the rail frame. While keeping a secure grip of the rail frame, lift it to a position so you can do the next step of removing the external cap.

**Note:** The rail frame is spring loaded, so keep a secure grip on it as you lift it so it does not snap up.

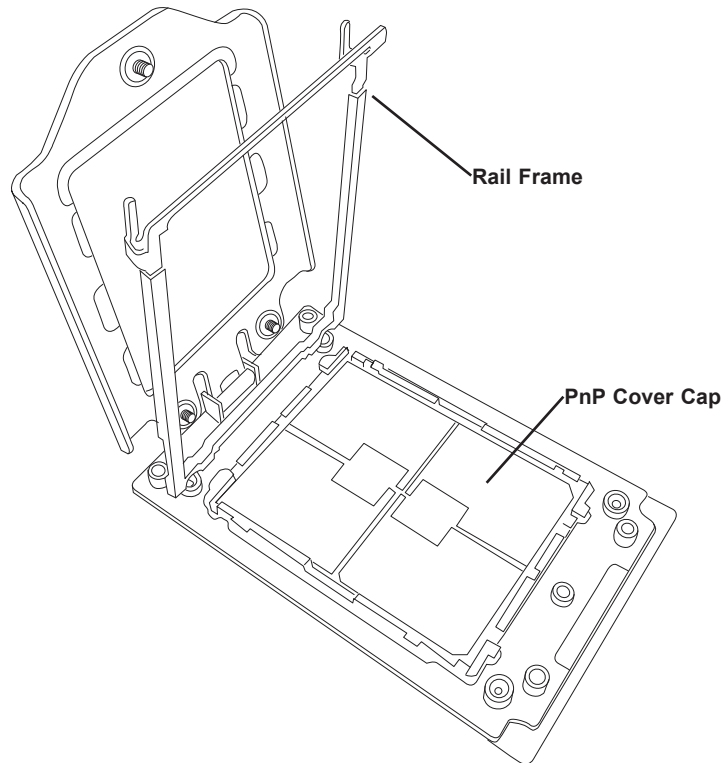

4. Remove the external cap from the rail frame by pulling it upwards through the rail guides on the rail frame.

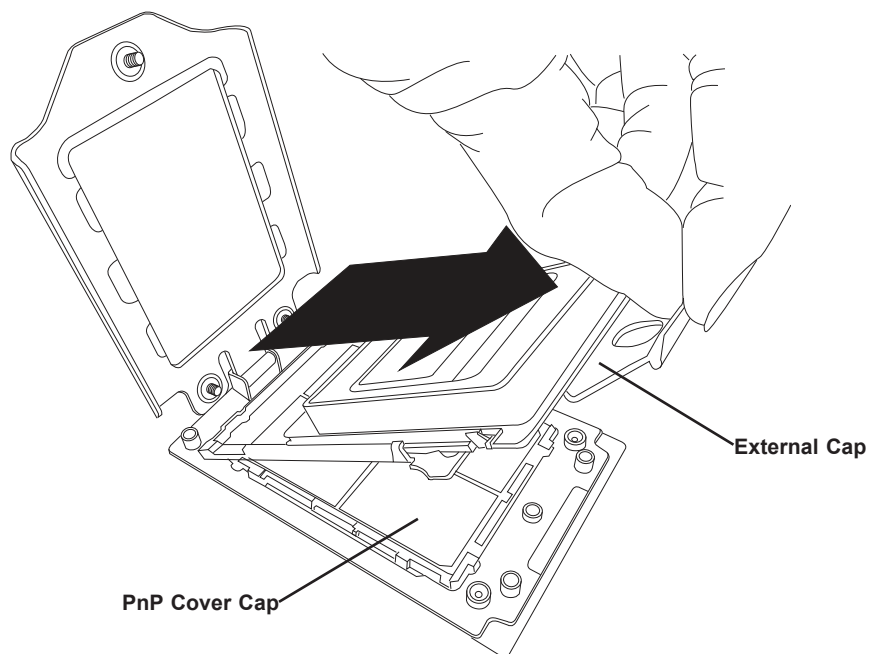

5. The CPU package is shipped from the factory with the carrier frame pre-assembled. Grip the handle of the carrier frame/CPU package assembly from its shipping tray, and while gripping the handle, align the flanges of the carrier frame onto the rails of the rail frame so its pins will be at the bottom when the rail frame is lowered later.
6. Slide the carrier frame/CPU package downwards to the bottom of the rail frame. Ensure the flanges are secure on the rails as you lower it downwards.

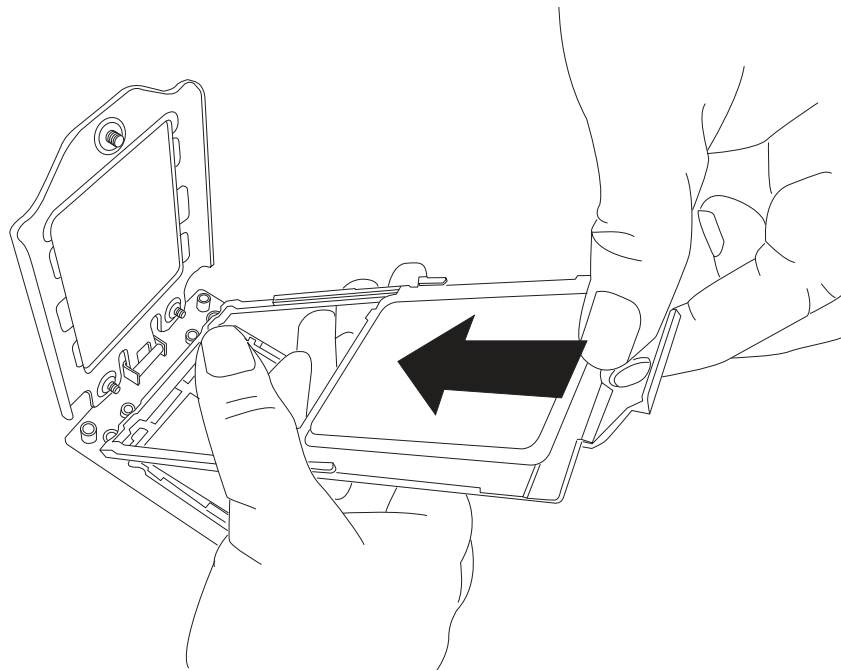

**Note:** You can only install the CPU inside the socket in one direction with the handle at the top. Make sure that it is properly inserted into the CPU socket before closing the rail frame plate. If it doesn't close properly, do not force it as it may damage your CPU. Instead, open the rail frame plate again, and double-check that the CPU is aligned properly.

7. Lift up the rail frame until it securely rests in upright position. Then remove the PnP cover cap from the CPU socket below. Grip the two lift tabs marked "Remove" at the middle of the cap and pull vertically upwards to remove the PnP cover cap.

**Warning!** The exposed socket contacts are extremely vulnerable and can be damaged easily. Do not touch or drop objects onto the contacts and be careful when removing the PnP cover cap and when placing the rail frame over the socket.

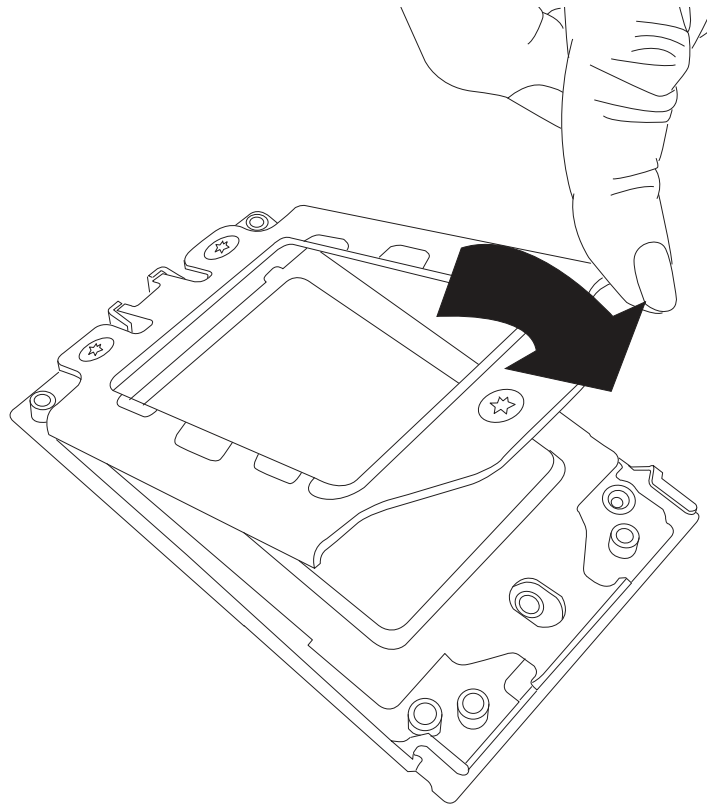

8. Gently lower the rail frame down onto the socket until the latches on the rail frame engage with the socket housing and rests in place. **DO NOT** force it into place!
9. Gently lower the force frame down onto the rail frame and hold it in place until it is seated in the socket housing. Note that the force frame is spring loaded and has to be held in place before it is secured. **Important: Use a torque screwdriver and set it at 16.1 kgf-cm (14.0 lbf-in) with a Torx T20 screw head bit to prevent damage to the CPU.**

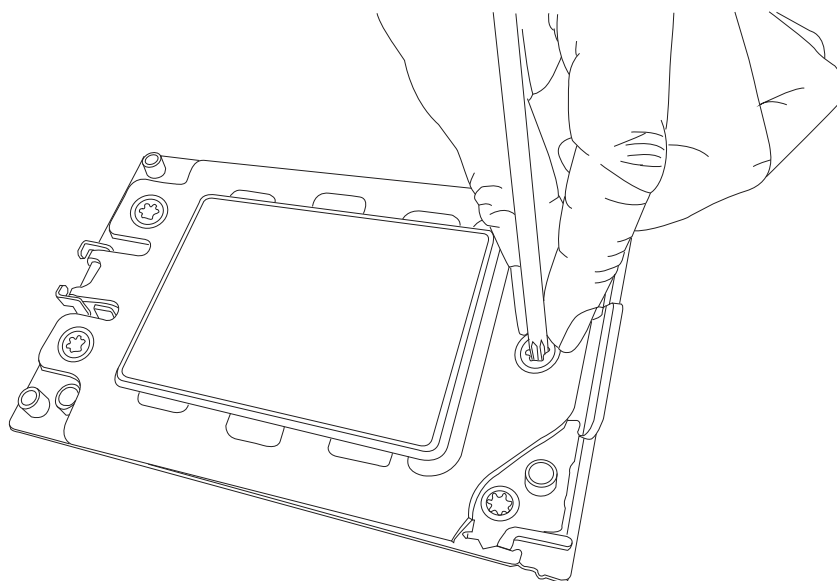



10. Place and re-screw the screws in the reverse order of the removal steps. When finished, the force frame will be secured over both the rail frame and the CPU package.

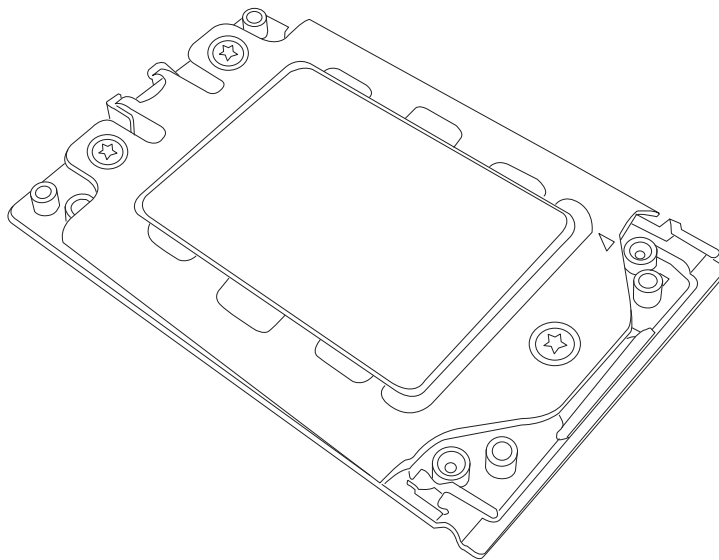

11. After the force frame is secured and the CPU package is in place, now you must install the heatsink to the frame. Lower the heatsink down till it rests securely over the four screw holes on CPU package on the socket frame.

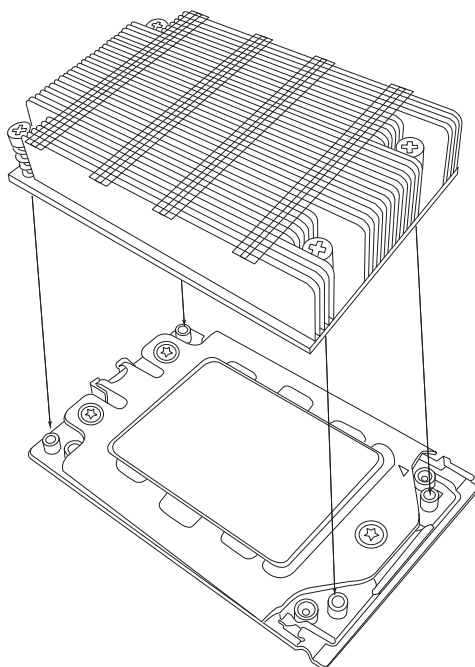

- Using a diagonal pattern, tighten the four screws down on the heatsink in a clockwise fashion till it is secure. The heatsink will now be secured and you have finished installing the processor and heatsink onto the motherboard. Repeat this procedure for any remaining CPU sockets on the motherboard.

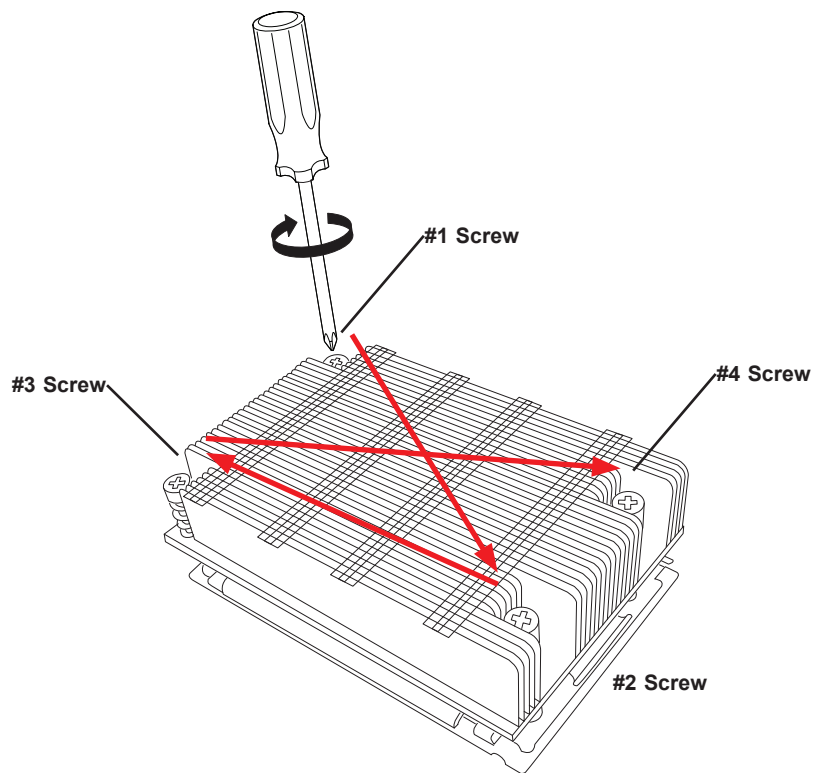

### **Un-installing the Processor and Heatsink**

1. Remove the heatsink attached to the top of the CPU package by reversing the installation procedure.
2. Clean the thermal grease left by the heatsink on the CPU package lid to limit the risk of it contaminating the CPU package land pads or contacts in the socket housing.
3. Reverse the procedure for installing the force frame onto the socket, unscrewing the plate in the 3-2-1 screw order and lift the force frame to the vertical position.
4. Lift the rail frame using the lift tabs near the front end of the rail frame. Note that the rail frame is spring loaded, so be careful lifting it up into a vertical position.
5. Grip the handle of the carrier frame and pull upwards to extract it from the rail frame. Return the carrier frame/CPU package to its original shipping container.
6. Grip the handle on the external cap and return it to the rail frame sliding it downwards until it rests in the frame.
7. Gripping the rail frame, rotate it downwards until it rests above and locks over the socket housing in its horizontal position.
8. Push and rotate down the force frame until it is over both the external cap and rail frame and in a horizontal position.
9. While holding down the force frame, secure it back to the socket frame by securing screw 1 in place. Note that without a CPU package in place, it is not necessary to tighten down screws 2 and 3 at this time.

## Memory Support and Installation

### Memory Support

The H12SST-PS supports up to 2TB of ECC DDR4 3200 MHz speed, RDIMM/LRDIMM/3DS/NVDIMM memory in eight slots. Refer to the tables below for more information about the memory modules.

**Note:** Check the Supermicro website for possible updates to memory support.

Processors and their Corresponding Memory Modules										
Channel										
CPU	D1	C1	B1	A1	CPU Socket SP3	E1	F1	G1	H1	
1 DIMM (Not Recommended)										
CPU		V								
2 DIMMs (Not Recommended)										
CPU		V					V			
4 DIMMs (Not Recommended)										
CPU	V	V						V	V	
8 DIMMs										
CPU	V	V	V	V			V	V	V	V

Populating RDIMM/RDIMM 3DS/LRDIMM/LRDIMM 3DS DDR4 Memory Modules				
Type	DIMM Population	Maximum DIMM Capacity (GB)		Maximum Frequency (MHz)
		1 Channel	8 Channels	
RDIMM	1R (1 Rank)	32GB	256GB	3200
	2R or 2DR (2 Ranks)	64GB	512GB	3200
LRDIMM	4DR (4 Ranks)	128GB	1TB	3200
	2S2R (4 Ranks)	128GB	1TB	3200
	2S4R (8 Ranks)	256GB	2TB	3200
LRDIMM 3DS	2S2R (4 Ranks)	128GB	1TB	3200
	2S4R (8 Ranks)	256GB	2TB	3200

### ***DIMM Module Population***

There is no specific order or sequence required when installing memory modules. However do keep the following in mind:

- Always use DDR4 DIMM modules of the same type, size and speed.
- Mixed DIMM speeds can be installed. However, all DIMMs will run at the speed of the slowest DIMM.
- The motherboard will support odd-numbered modules (1 or 3 modules installed). However, to achieve the best memory performance, fully populate the motherboard with validated memory modules.

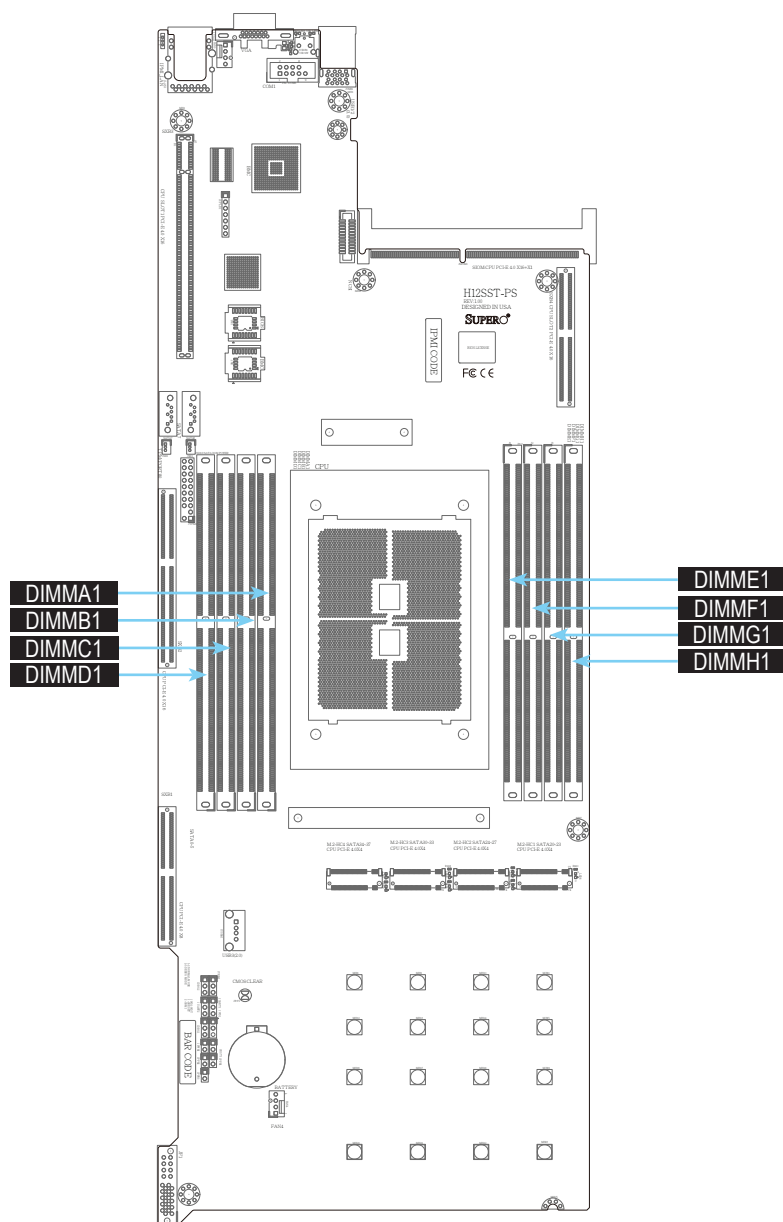

**Figure 3-2. DIMM Numbering**

### ***DIMM Installation***

**Caution:** Exercise extreme caution when installing or removing memory modules to prevent any possible damage to the DIMMs or slots.

Begin by removing power from the system as described in Section 3.1.

1. Decide on the number of DIMMs to install and follow the DIMM population sequence table in Section 3.3 Memory Support and Installation.
2. Push the release tabs outwards on both ends of the DIMM slot to unlock it.

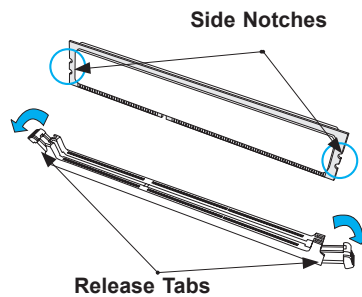

3. Identify the notches on the side and bottom of the DIMM module.

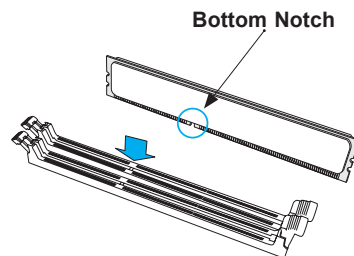

4. Align the bottom notch on the DIMM module with the receptive point in the memory slot. Align the side notches with the receptive points on the release tabs.

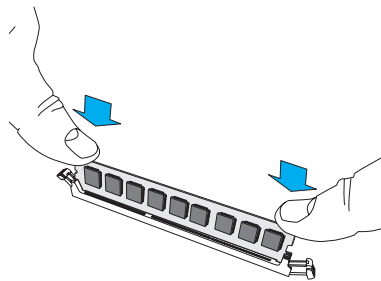

5. With your thumbs on both ends of the DIMM module, press it straight down into the slot until the module snaps into place.
6. Press the release tabs to the locked position to secure the DIMM module into the slot.

### ***DIMM Removal***

To remove a DIMM, unlock the release tabs then pull the DIMM from the memory slot.



## Motherboard Battery

The motherboard uses non-volatile memory to retain system information when system power is removed. This memory is powered by a lithium battery residing on the motherboard.

### *Replacing the Battery*

Begin by removing power from the system as described in Section 3.1.

1. Push aside the small clamp that covers the edge of the battery. When the battery is released, lift it out of the holder.
2. To insert a new battery, slide one edge under the lip of the holder with the positive (+) side facing up. Then push the other side down until the clamp snaps over it.

**Note:** Handle used batteries carefully. Do not damage the battery in any way; a damaged battery may release hazardous materials into the environment. Do not discard a used battery in the garbage or a public landfill. Please comply with the regulations set up by your local hazardous waste management agency to dispose of your used battery properly.

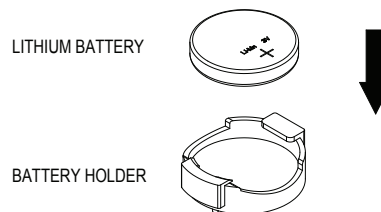

**Figure 3-4. Installing the Onboard Battery**

**Warning:** There is a danger of explosion if the onboard battery is installed upside down (which reverses its polarities). This battery must be replaced only with the same or an equivalent type recommended by the manufacturer (CR2032).



## 3.4 Chassis Components

### Hard Drives

You do not need to access the inside of the chassis or remove power to replace or swap drives. Proceed to the next step for instructions. You must use standard 3.5 inch drives in the system.

**Note:** Refer to Supermicro's website for setup guidelines: <<http://www.supermicro.com/support/manuals/>>.

The SC827HQ+ chassis contains four individual serverboards in separate node drawers (Figure 3-5). Each serverboard node controls a set of three hard drives. Note that if a serverboard node drawer is pulled out of the chassis, the hard drives associated with that node will power down as well.

Serverboard Drawer Locations in the Chassis	
Serverboard B Controls HDDs B1, B2 and B3	Serverboard D Controls HDDs D1, D2 and D3
Serverboard A Controls HDDs A1, A2 and A3	Serverboard C Controls HDDs C1, C2 and C3

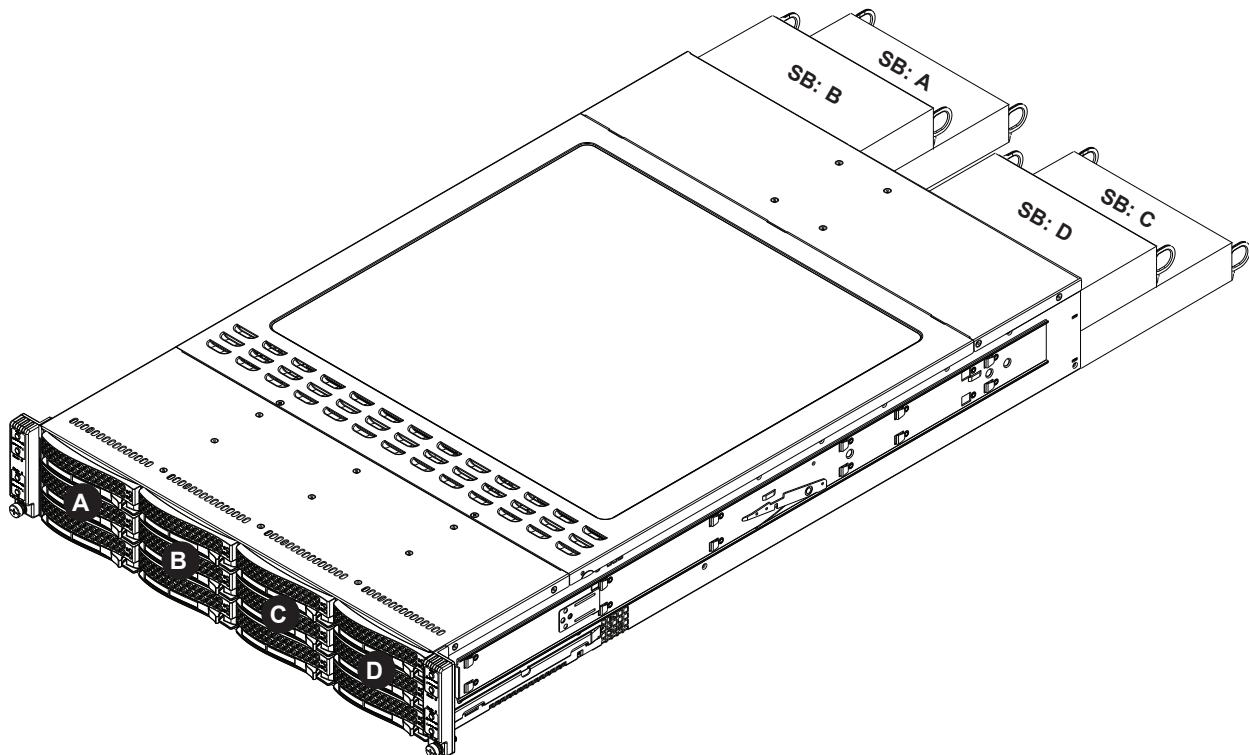
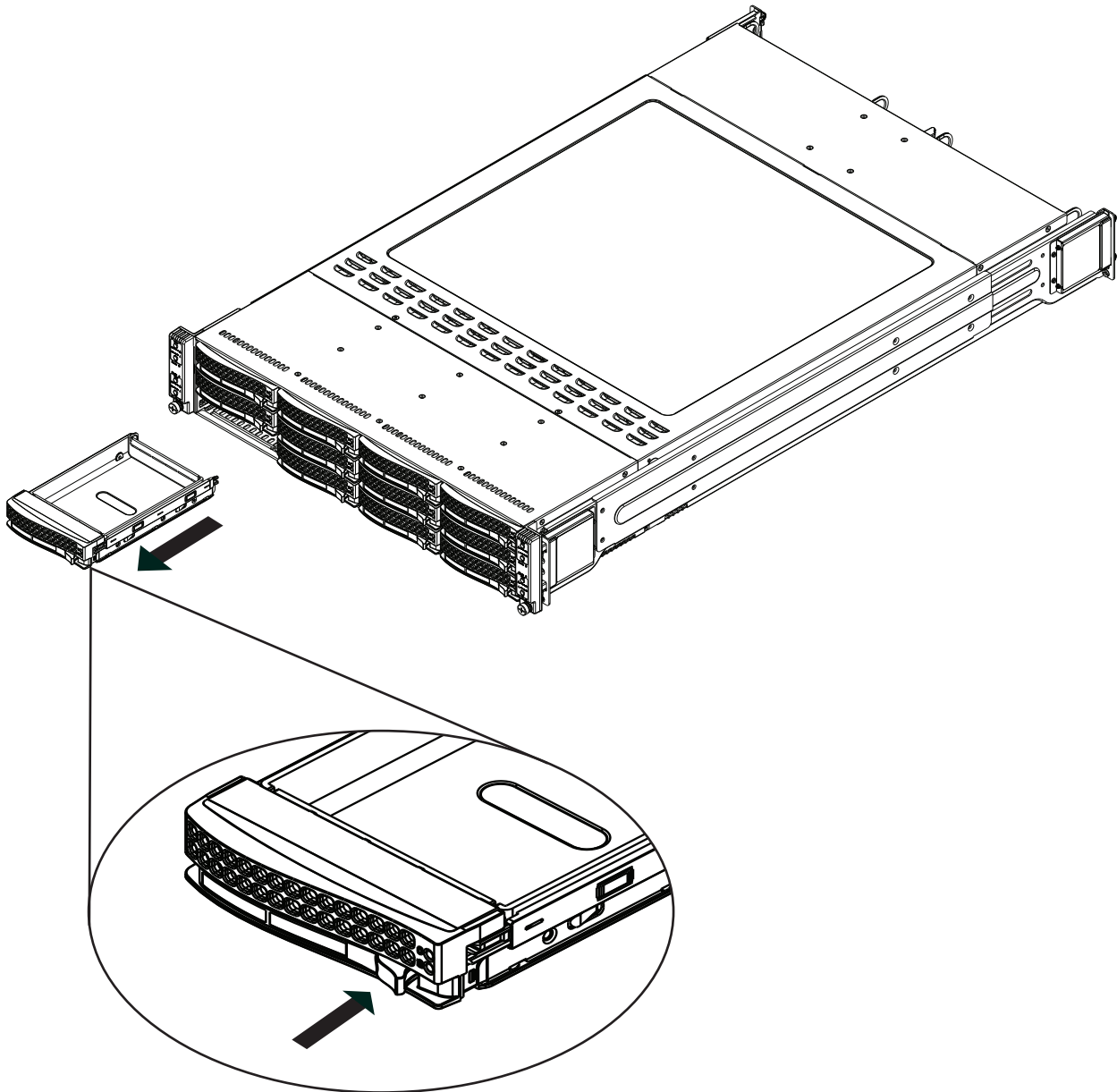

Figure 3-5. Hard Drives and their Corresponding Serverboard Nodes

### ***Removing a Drive Carrier from the Chassis***

1. Press the release button on the drive carrier. This extends the drive bay handle.
2. Use the handle to pull the drive out of the chassis.



**Figure 3-6. Removing a Drive Carrier**

The drives are mounted in drive carriers to simplify their installation and removal from the chassis (Figure 3-7 and Figure 3-8). These carriers also help promote proper airflow for the drive bays.

### ***Installing a Drive into the Hard Drive Tray***

1. Remove the screws holding the drive tray and the carrier.
2. Remove the tray from the carrier.

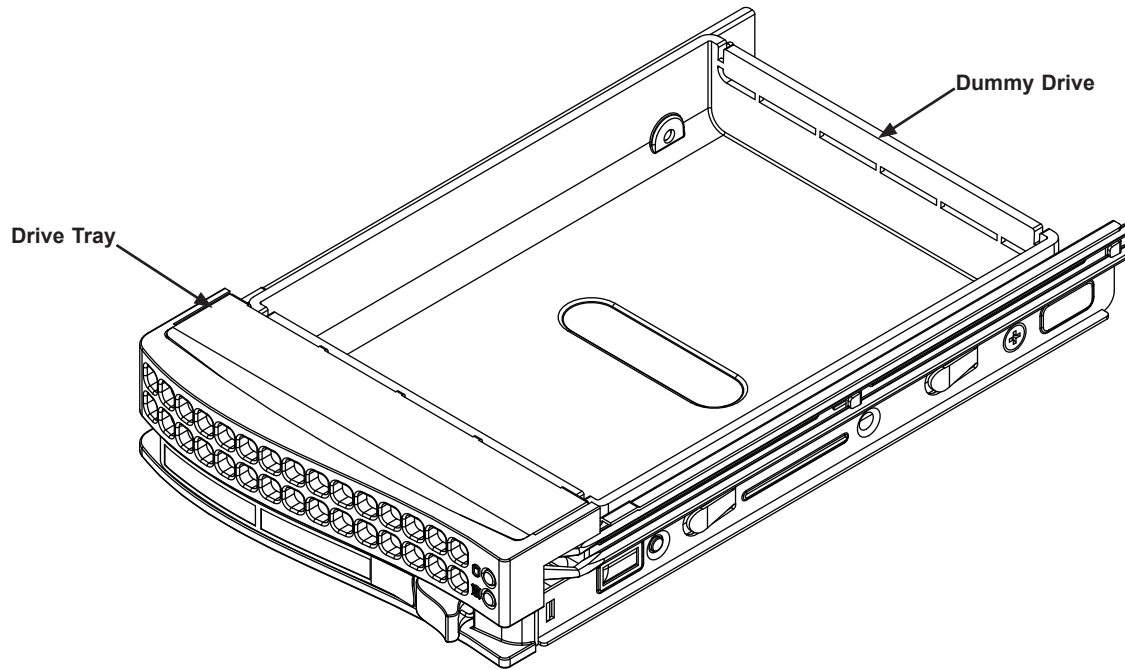

Figure 3-7. Chassis Drive Tray

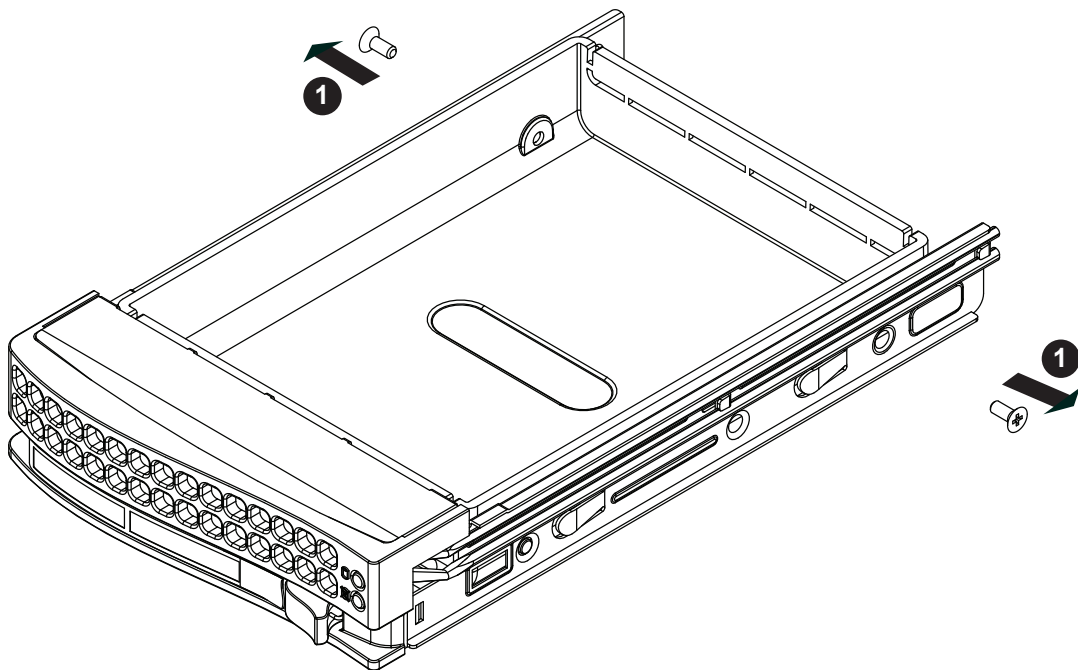
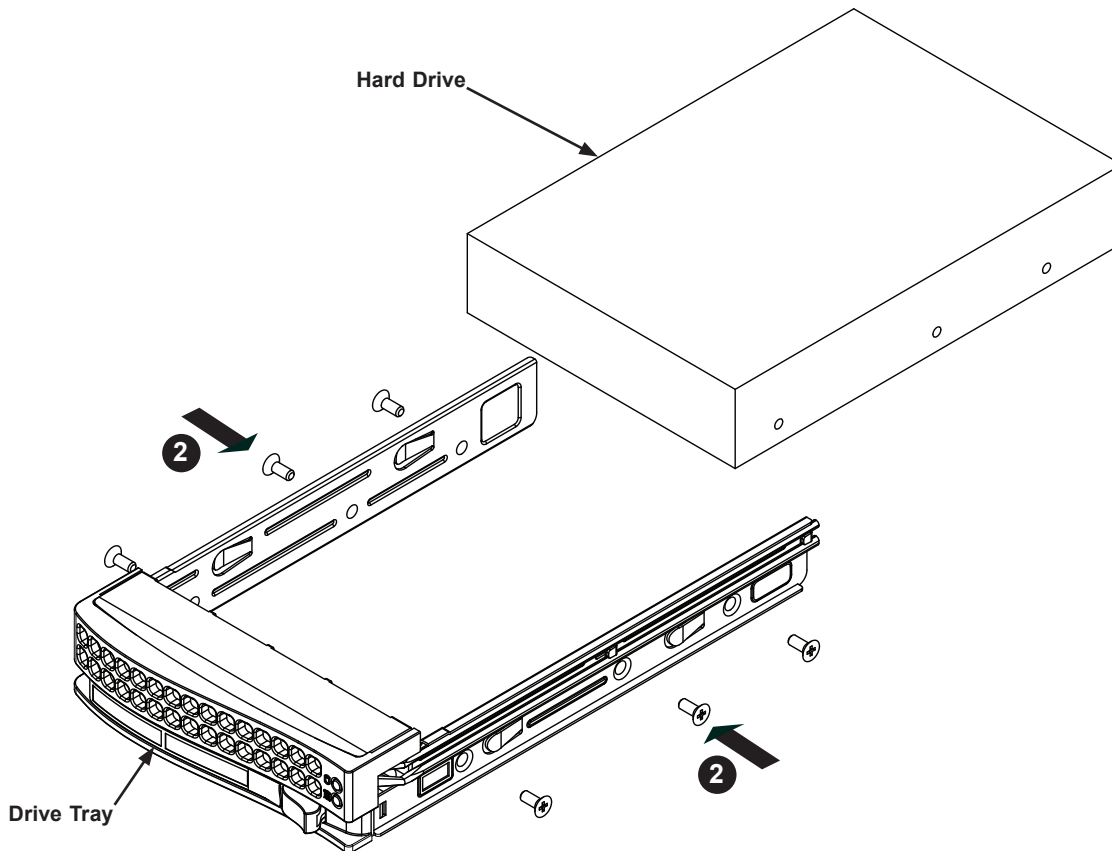

Figure 3-8. Removing Dummy Drive from Tray

**Caution:** Except for short periods of time while swapping hard drives, do not operate the server with the hard drives empty.

### Installing the Hard Drive

1. Install a new drive into the carrier with the printed circuit board side facing down so that the mounting holes align with those in the carrier.
2. Secure the hard drive by tightening all six screws.
3. Use the open handle to replace the drive tray into the chassis. Make sure to close the drive tray handle.



**Figure 3-9. Installing the Hard Drive**

**Note:** Enterprise level hard disk drives are recommended for use in Supermicro chassis and servers. For information on recommended HDDs, visit the Supermicro website at <https://www.supermicro.com/support/resources/HDD/systemHDD.cfm?ProductID=86917>.

### Hard Drive Carrier Indicators

Each hard drive carrier has an activity LED indicator. See below for the LED description.

	LED Color	State	Status
Activity LED	Blue	Solid On	SATA drive installed
	Blue	Blinking	I/O activity

## System Cooling

Four 8-cm fans provide cooling for the system. The SC827HQ+ system fans are easy-to-change modules. There is no need to uninstall any other parts inside the system when replacing fans. These fans are NOT redundant and must be replaced when they fail.

It is very important that the chassis top cover is installed for the cooling air to circulate properly through the chassis and cool the components.

## Optional Fan Configurations

The SC827HQ+ model chassis is designed so that the default configuration of the system is for each serverboard to control two fans (Figure 3-10). The fans are hot-swappable. Each serverboard node in the chassis is connected to the backplane through the adapter card, mounted in the serverboard drawer. In the event that one of the serverboard drawers is removed, then the remaining serverboard will operate both fans.

Fan Configurations Options
<b>SC827HQ+ Hot-Swappable Default Configuration</b>
Fan A connected to backplane, backplane connected to Node A by adapter card
Fan B connected to backplane, backplane connected to Node B by adapter card
Fan C connected to backplane, backplane connected to Node C by adapter card
Fan D connected to backplane, backplane connected to Node D by adapter card

## Installing Fans

Fan speed is controlled by system temperature via IPMI. If a fan fails, the remaining fans will ramp up to full speed. Replace any failed fan at your earliest convenience with the same type and model (the system can continue to run with a failed fan).

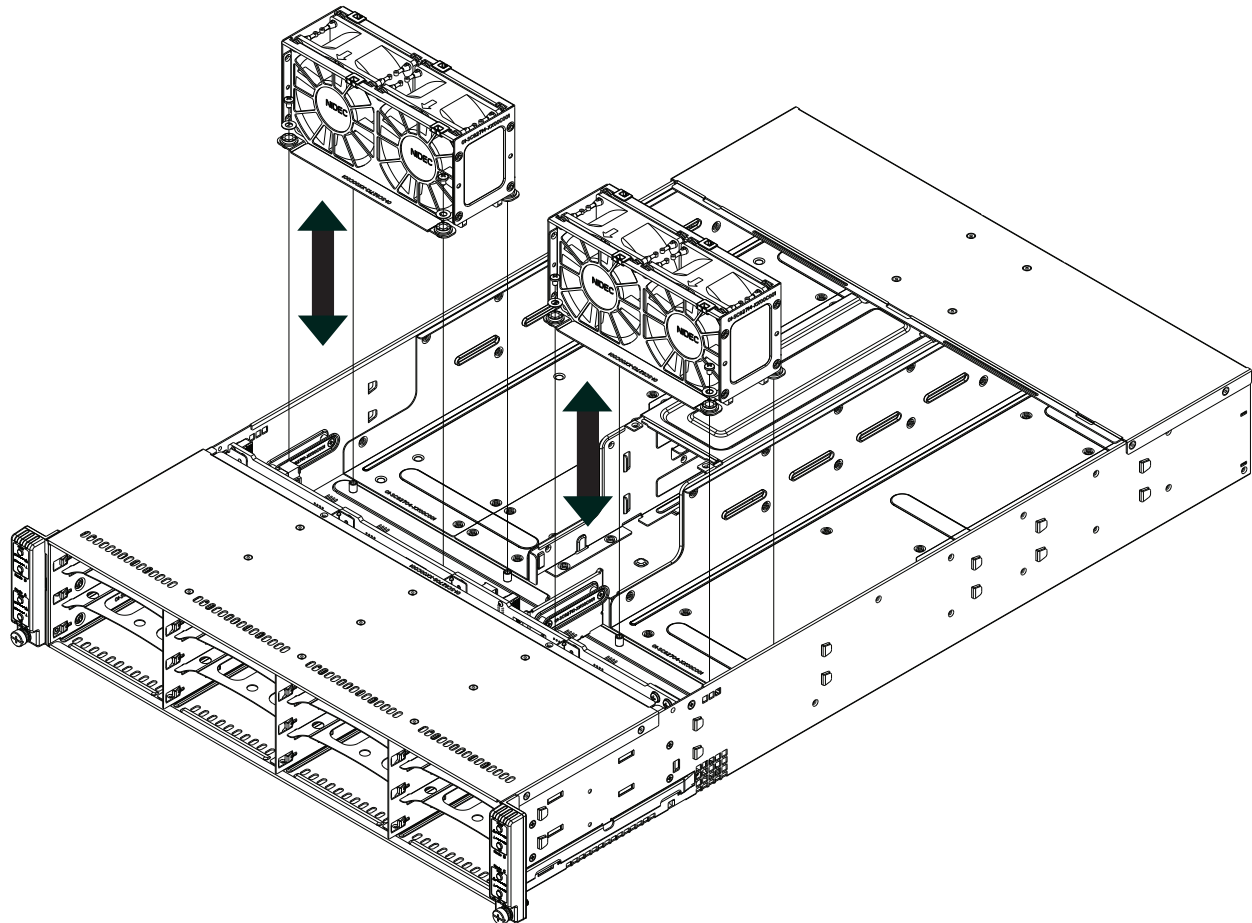

**Figure 3-10. System Fan Placement**

### ***Changing a System Fan***

1. If necessary, open the chassis while the power is running to determine which fan has failed. (Never run the server for an extended period of time with the chassis cover open.)
2. Remove the failed fan's power cord from the backplane.
3. Lift the fan housing up and out of the chassis.
4. Push the fan up from the bottom and out of the top of the housing.
5. Place the replacement fan into the vacant space in the housing while making sure the arrows on the top of the fan (indicating air direction) point in the same direction as the arrows on the other fans.
6. Put the fan back into the chassis and reconnect the cable.
7. Confirm that the fan is working properly before replacing the chassis cover.

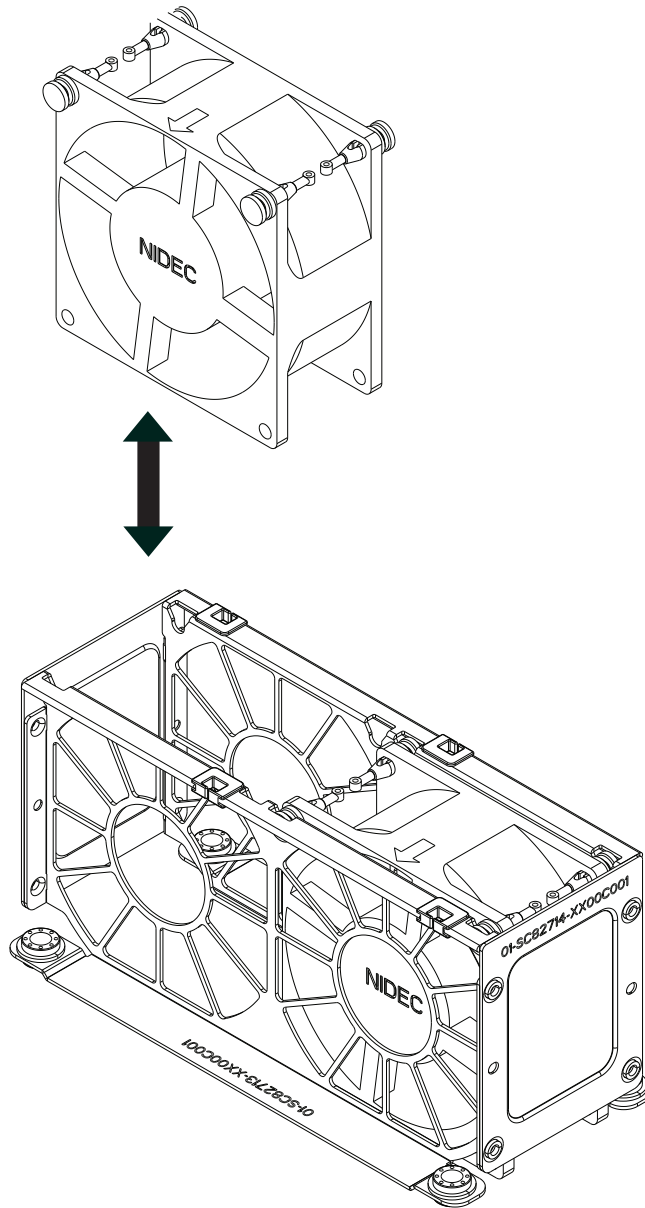

Figure 3-11. Replacing a System Fan

### ***Air Shroud***

The air shroud is used to concentrate airflow to maximize fan efficiency. The air shroud requires two screws to set up. There is one air shroud for each motherboard drawer.

#### ***Installing the Air Shroud***

1. Lay the chassis on a flat, stable surface and remove the motherboard drawer from the chassis.
1. Make sure that the motherboard expansion card (if applicable) and all components are properly installed in each motherboard node.
2. If necessary, move any cables that interfere with the air shroud placement.
3. Place the air shroud in the motherboard drawer and secure with two screws.
4. Repeat the procedure for the remaining three motherboard nodes.
5. Insert the motherboard drawer into the chassis.

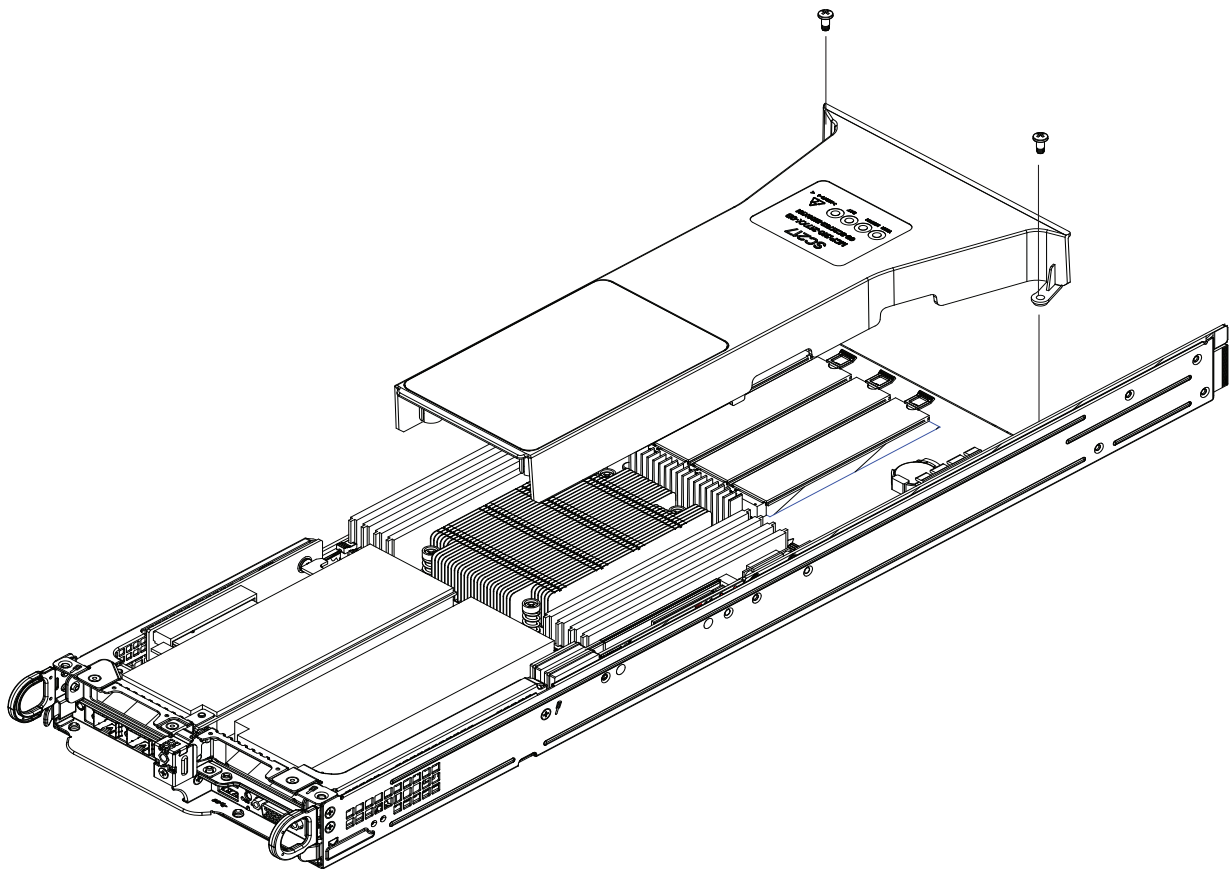
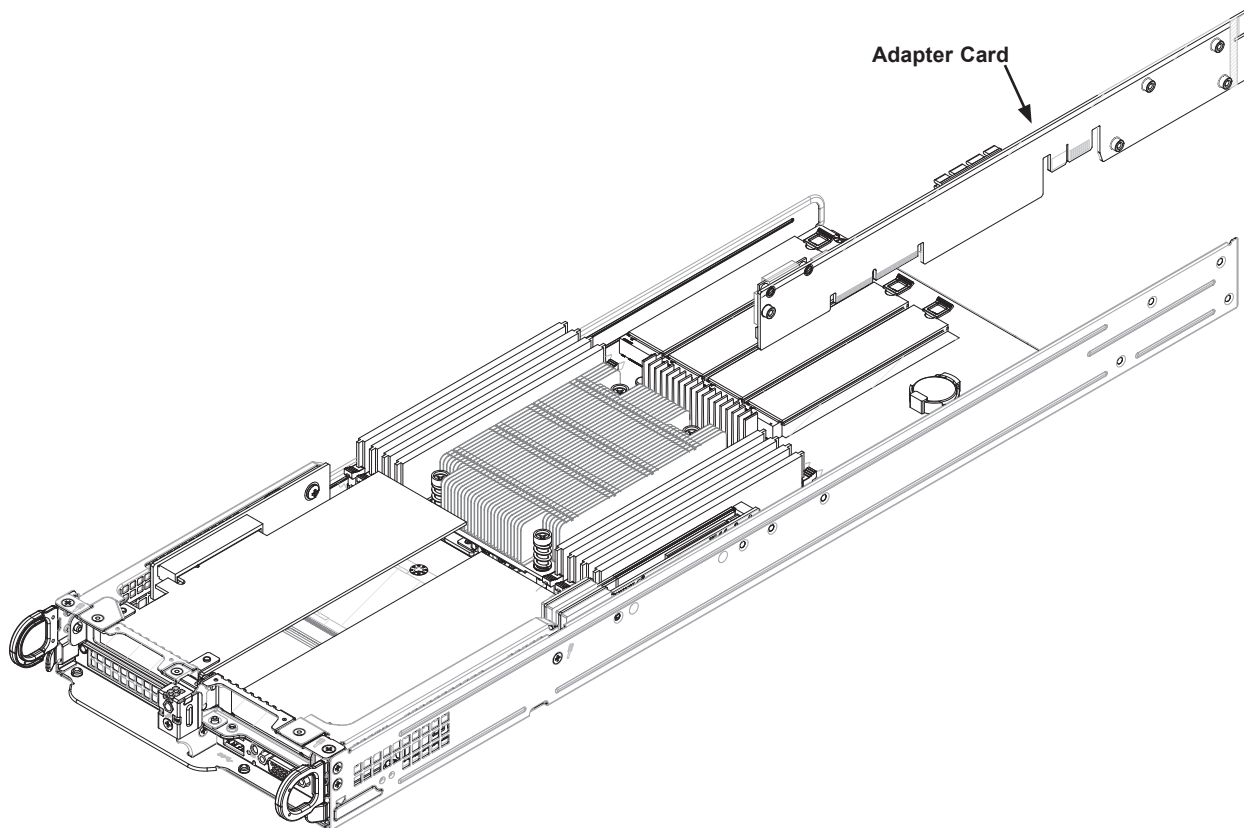

**Figure 3-12. Installing the Air shroud**



## Adapter Card Replacement

Each motherboard drawer comes equipped with an adapter card which plugs into the backplane. In the unlikely event that the adapter card needs to be replaced, installation requires only a Phillips head screwdriver.



**Figure 3-13. Adapter Card Installation**

### ***Removing the Adapter Card***

1. Remove power from the system as described in Section 3.1.
2. Remove the motherboard drawer from the chassis by pulling the pulling ears.
3. Disconnect the wiring connecting the adapter card to the motherboard.
4. Remove the five screws securing the adapter card to the drawer and set them aside for later use.
5. Remove the adapter card from the motherboard drawer.

***Installing the Adapter Card***

1. Insert the adapter card into the motherboard expansion slot.
2. Align the holes in the adapter card with the holes in the motherboard drawer.
3. Secure the adapter card to the motherboard drawer using the five screws which were previously set aside.
4. Reconnect the wiring from the motherboard to the adapter card.
5. Insert the motherboard drawer into the chassis.

## SIOM Modules

The AS -2014TP-HTR is designed to accept several SIOM modules (Supermicro I/O Module) to satisfy the specific I/O functions required by the system. The various SIOM modules are as follows:

- AOC-MGP-i2M: two RJ45 (1GbE) ports supported by an Intel i350-AM2 controller.
- AOC-MGP-i4M: four RJ45 (1GbE) ports supported by an Intel i350-AM4 controller.
- AOC-MTGN-i2SM: two SFP+ (10GbE) ports supported by an Intel 82599ES controller.
- AOC-MTGN-i4SM: four SFP+ (10GbE) ports supported by an Intel XL710-BM1 controller.
- AOC-MTG-i2TM: two RJ45 (10GbE) ports supported by an Intel X550 controller.
- AOC-MTG-i4TM: four RJ45 (10GbE) ports supported by an Intel X550 controller.
- AOC-MTG-b2TM: two RJ45 (10GbE) ports supported by a Broadcom BCM57416 controller.
- AOC-MH25G-b2S2GM: two SFP28 (25GbE) ports supported by a Broadcom BCM57414 controller, two RJ45 (1GbE) ports supported by an Intel i350-AM2 controller.
- AOC-MH25G-m2S2TM: two SFP28 (25GbE) ports supported by a Mellanox ConnectX-4 controller, two RJ45 (10GbE) ports supported by an Intel X550-AT2 controller.
- AOC-M25G-m4SM: four SFP28 (25GbE) ports supported by a Mellanox ConnectX-4 controller.
- AOC-M25G-i2SM: dual SFP28 (25GbE) ports supported by an Intel XXV710 controller
- AOC-MHIBF-m2Q2GM: two RJ45 (40GbE) supported by an Intel i350 controller, and two QSFP (56GbE) supported by an Mellanox® ConnectX-3 Pro InfiniBand FDR controller
- AOC-MHIBF-m1Q2GM: two RJ45 (40GbE) supported by an Intel i350 controller, and one QSFP (56GbE) supported by an Mellanox® ConnectX-3 Pro InfiniBand FDR controller

### ***Installing an SIOM Module into the Motherboard Drawer***

1. Remove the four screws securing the two riser brackets in the node. Remove the screw at the center of the pulling bracket. See Figure 3-3 in Section 3.3.
2. Remove the seven screws securing the pulling bracket to the node. See Figure 3-14.
3. Remove the screw holding the SIOM shield on the pulling bracket. See Figure 3-15. Install the correct I/O shield. See Figure 3-16.
4. Remove the two screws holding the SIOM module and carefully disconnect the module from the motherboard. See Figure 3-17.
5. Connect a new SIOM module and replace the two screws on the SIOM module using about 3-pounds of torque.
6. Replace the pulling bracket and secure the seven screws from Step 2 above.
7. Replace the two riser card brackets and secure the five screws from Step 1 above.
8. Insert the motherboard drawer into the chassis.

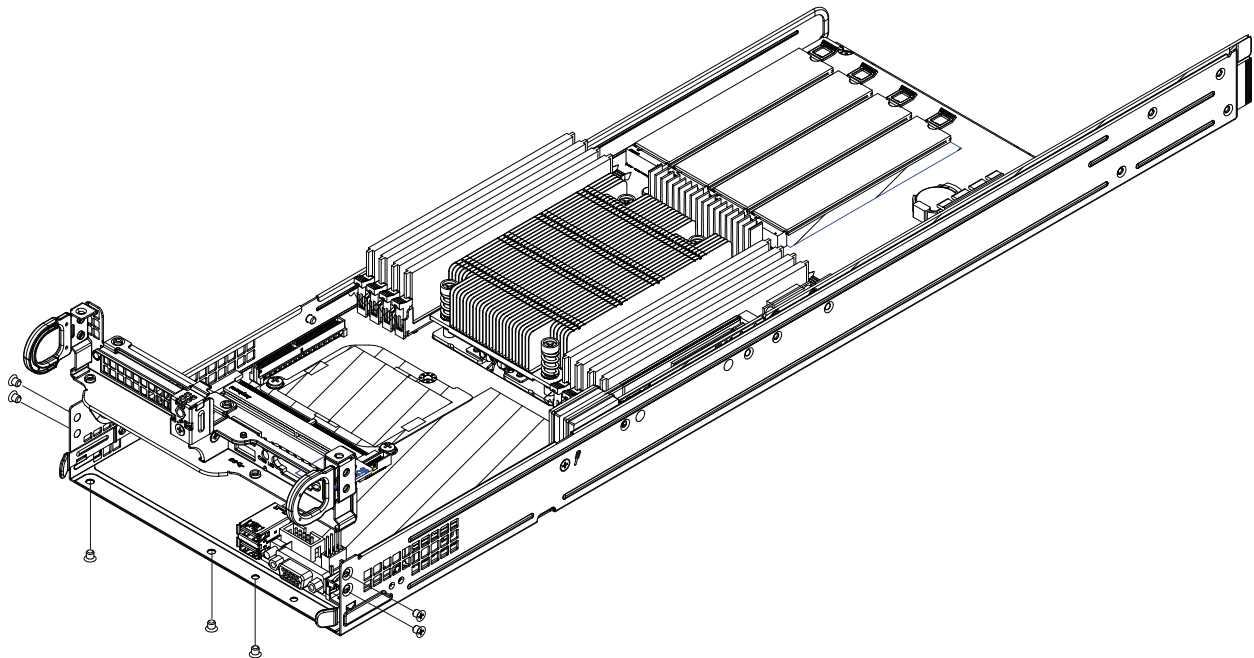

**Figure 3-14. Removing Seven Screws from the Pulling Bracket**

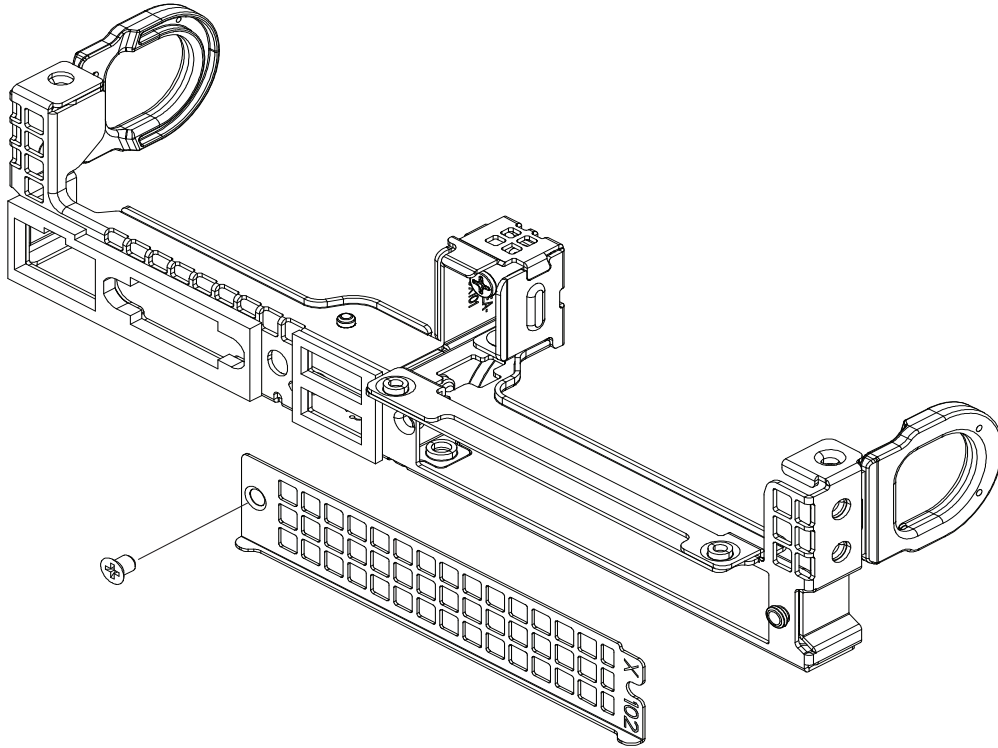

**Figure 3-15. Removing the SIOM Shield from the Pulling Bracket (Inner View)**

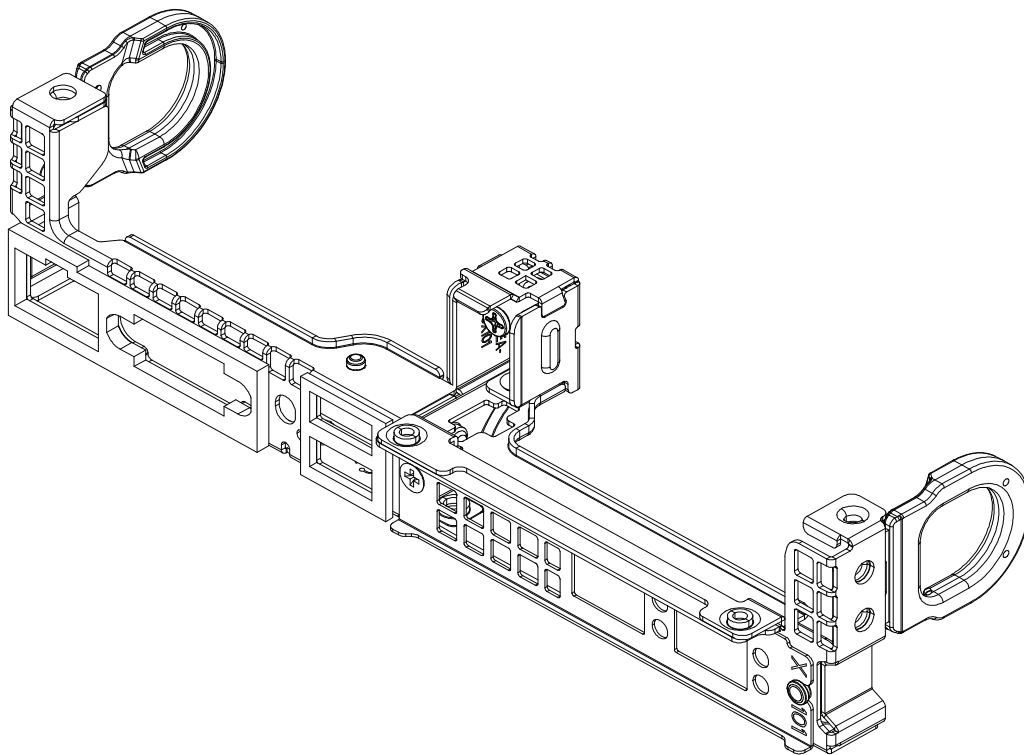

**Figure 3-16. Installing SIOM Shield (Inner View)**

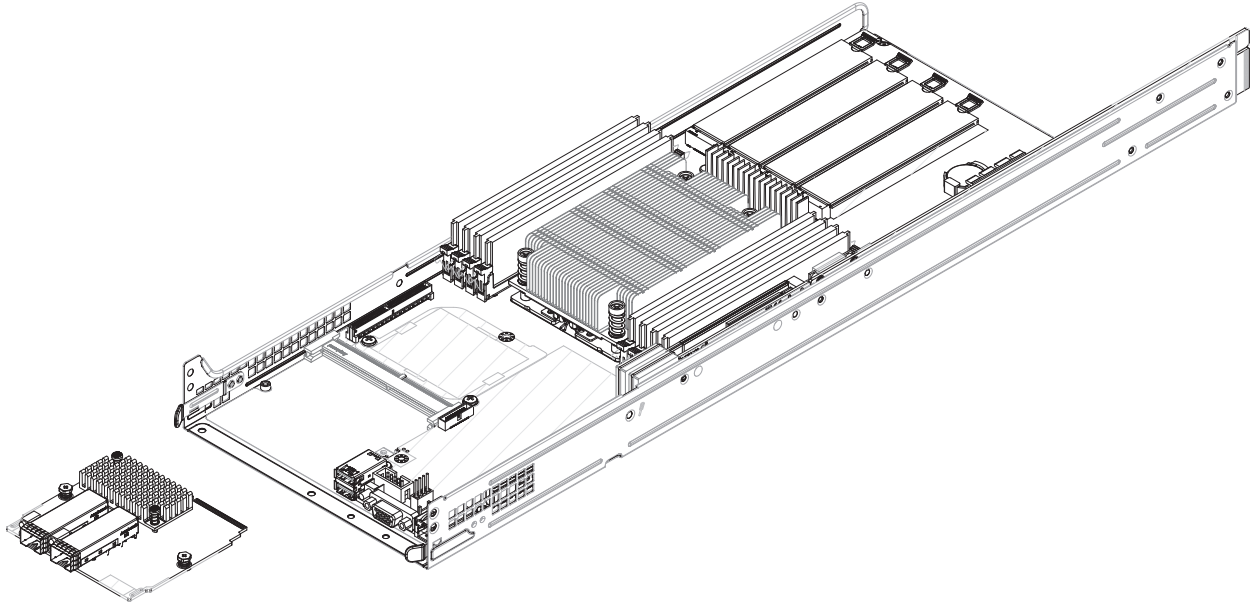

**Figure 3-17. Insert the SIMM into the Motherboard Drawer**

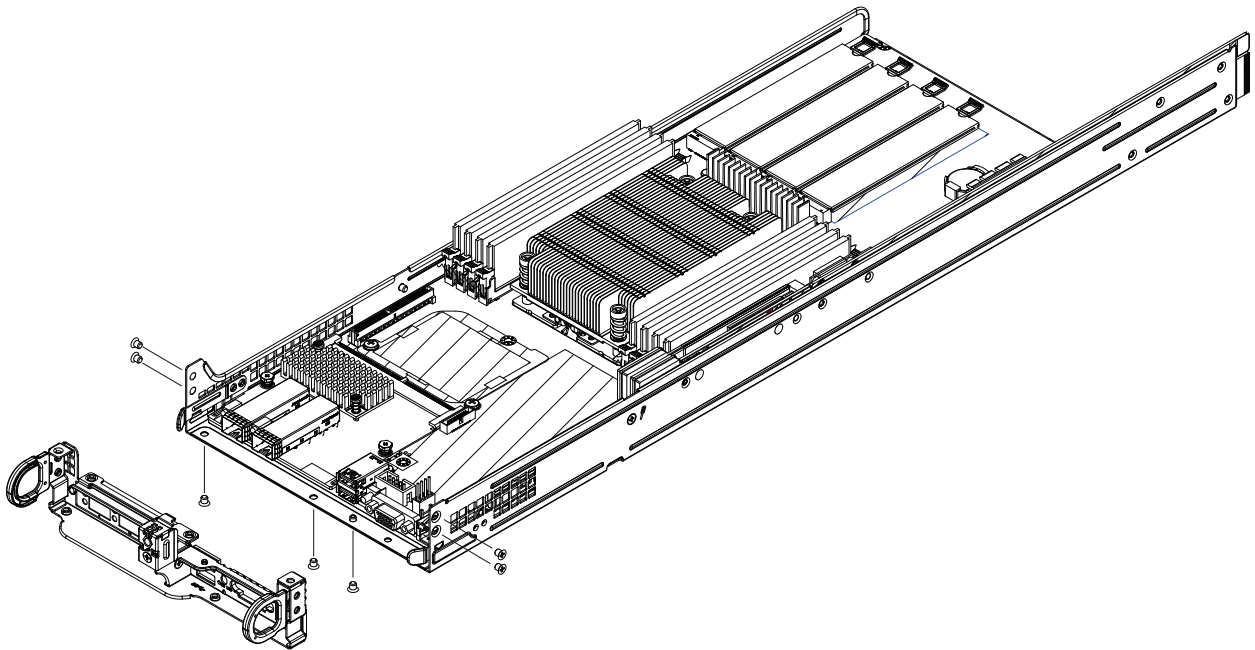

**Figure 3-18. Replace the Pulling Bracket**

## Power Supply

The AS -2014TP-HTR has two high-efficiency 2000 Watt power supplies, which is auto-switching capable. This enables it to automatically sense and operate with a 100V to 240V input voltage.

### ***Power Supply Replacement***

The SC827HQ+ chassis utilizes two redundant power supplies. In the unlikely event that the power supply unit needs to be replaced, one power supply can be removed, without powering down the system. Replacement units can be ordered directly from Supermicro (see the contact information in the Preface of this manual).

### ***Changing the Power Supply***

1. Push the release tab (on the back of the power supply) as illustrated.
2. Pull the power supply out using the handle provided.
3. Push the new power supply module into the power bay until you hear a click.
4. Plug the AC power cords back into both modules and power up the nodes.

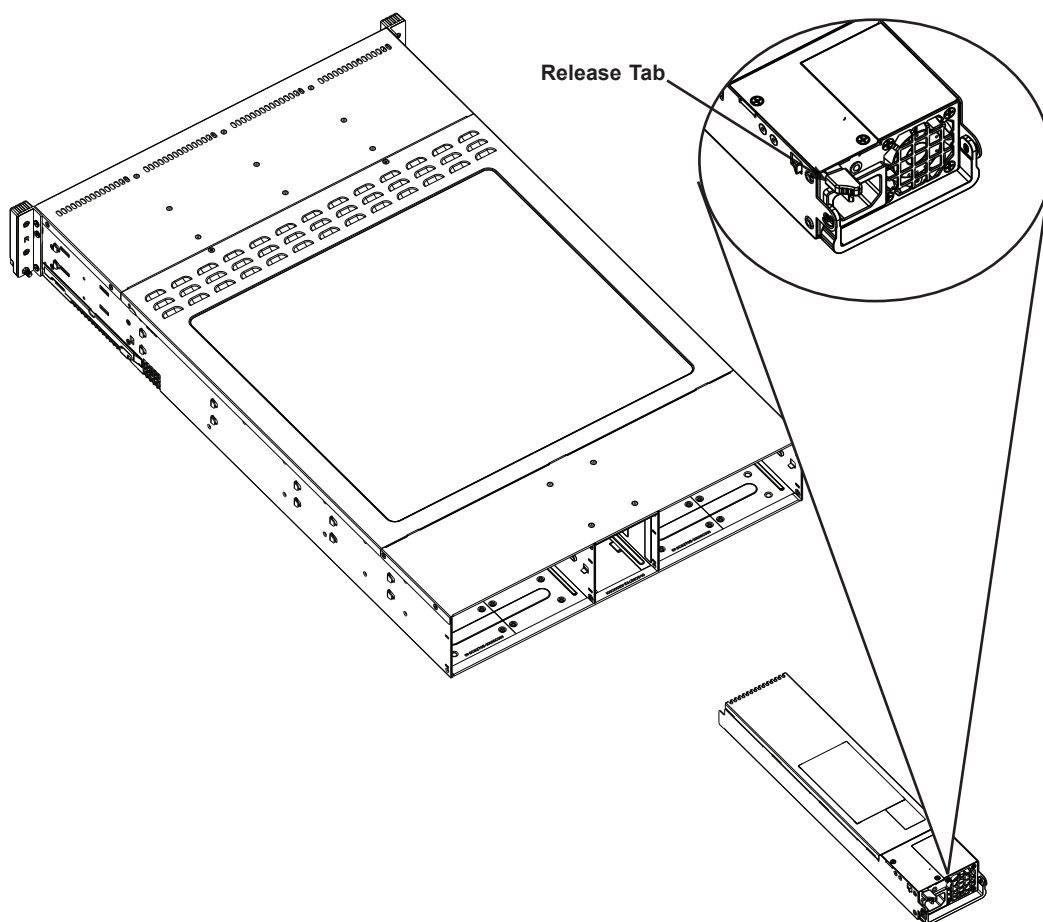

**Figure 3-19. Removing/Replacing a Power Supply**

# Chapter 4

## Motherboard Connections

This section describes the connections on the motherboard and provides pinout definitions. Note that depending on how the system is configured, not all connections are required. The LEDs on the motherboard are also described here. A motherboard layout indicating component locations may be found in Chapter 1.

Please review the Safety Precautions in Appendix B before installing or removing components.

### 4.1 Headers and Connectors

#### SATA Ports

The H12SST-PS has six available SATA 3.0 ports (SATA0~5) via a backplane supported by CPU. The yellow SATA6 and SATA7 connectors support Super-DOM® with +5V power integrated in the SATA connector.

SATA Connectors Pin Definitions	
Pin#	Signal
1	Ground
2	SATA_TXP
3	SATA_TXN
4	Ground
5	SATA_RXN
6	SATA_RXP
7	Ground

#### Disk-On-Module Power Connector (Optional)

The Disk-On-Module (DOM) power connector at JSD1 provides 5V power to a solid-state DOM storage device connected to one of the SATA ports. See the table below for pin definitions.

DOM Power Pin Definitions	
Pin#	Definition
1	5V
2	Ground
3	Ground



### TPM Header/Port 80 Connector

The JTPM1 header is used to connect a Trusted Platform Module (TPM), which is available from a third-party vendor. A TPM is a security device that supports encryption and authentication in hard drives. It enables the motherboard to deny access if the TPM associated with the hard drive is not installed in the system.

Please go to the following link for more information on TPM: <http://www.supermicro.com/manuals/other/TPM.pdf>.

Trusted Platform Module Header Pin Definitions			
Pin#	Definition	Pin#	Definition
1	LCLK	2	GND
3	LFRAME#	4	Key
5	LRESET#	6	N/C
7	LAD3	8	LAD2
9	3.3V	10	LAD1
11	LAD0	12	GND
13	SMB_CLK (optional)	14	SMB_DAT (optional)
15	P3V3_STBY	16	SERIRQ
17	GND	18	LP_CLKRUN (optional)
19	LPC_PD (optional)	20	LPC_DRQ (optional)

### PCI-E M.2 Connectors

The PCI-E M.2 connectors (M.2-HC1 to M.2-HC4) are for devices such as memory cards, wireless adapters, etc. These devices must conform to the PCI-E M.2 specifications (formerly known as NGFF). This particular PCI-E M.2 supports M-Key (PCI-E x4 or SATA) storage card.

### USB 3

The internal USB3 (USB 2.0) Type-A connector provides an internal access port with extensive USB devices, as well as USB DOM.

USB3 (2.0) Pin Definitions	
Pin#	Definition
1	+5V
2	D-
3	D+
4	Ground

## Expansion Slots

The H12SST-PS motherboard features several expansion slots. These slots are supported by riser cards that are included with the system. The table below describes their functions.

Expansion Slots	
Name	Description
<b>SXB1</b>	PCI-E 4.0 x8 Slot and SATA Connections (SATA0~5)
<b>SXB2</b>	PCI-E 4.0 x16 Slot
<b>SXB3</b>	PCI-E 4.0 x16 Left Hand Riser Slot
<b>SXB4</b>	PCI-E 4.0 x16 Right Hand Riser Slot
<b>SIOM</b>	PCI-E 4.0 x16+x1 Slot for Proprietary Add-on Module
<b>JF1</b>	Front Control Panel Slot

## Onboard Battery

The onboard backup battery is located at BT1. The onboard battery provides backup power to the on chip CMOS, which stores the BIOS setup information. It also provides power to the Real Time Clock (RTC) to keep it running.

## 4.2 Ports

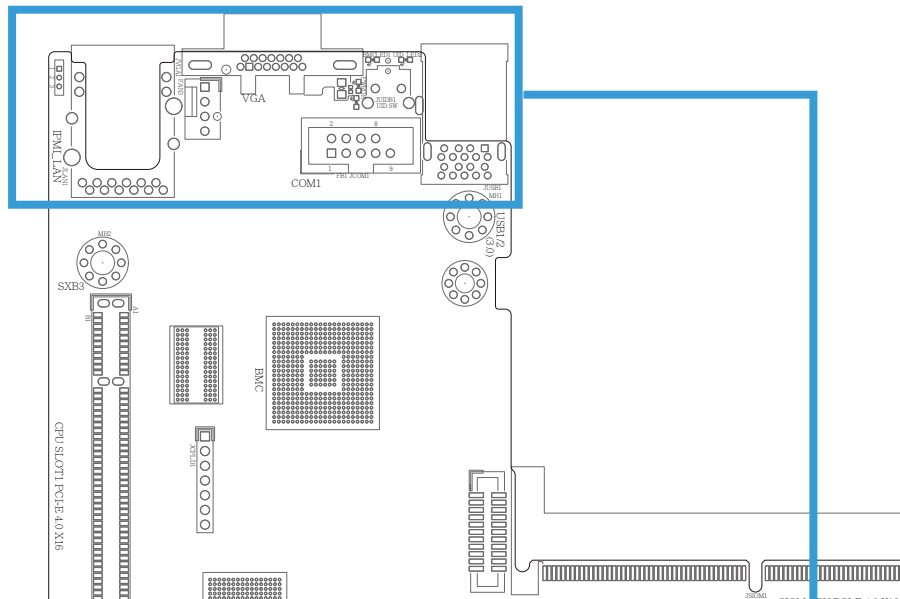
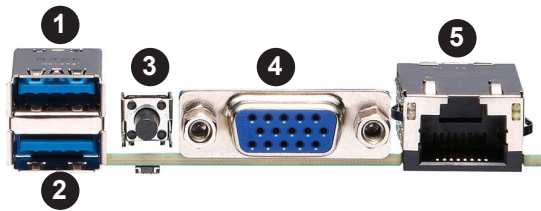

Figure 4-1. I/O Port Locations and Definitions



Rear I/O Ports			
#	Description	#	Description
1.	USB 1 (3.0)	4.	VGA Port
2.	USB 2 (3.0)	5.	IPMI LAN Port
3.	UID Switch		

### VGA Port

There is one VGA port on the rear I/O panel.

### IPMI LAN Port

One IPMI LAN port is located on the I/O back panel. This port accepts an RJ45 type cable.

### **Universal Serial Bus (USB) Ports**

There are two USB 3.0 ports (USB1/2) on the I/O back panel. These support Type-A connectors.

### **UID Switch and LED Indicator**

A Unit Identifier (UID) switch and UID LED are located on the I/O backpanel. The rear UID LED is located next to the UID switch. When you press the UID switch, both rear and front UID LED indicators will turn on. Press the UID switch again to turn off the LED indicators. The UID Indicator provides easy identification of a system that may be in need of service.

**Note:** UID can also be triggered via IPMI on the motherboard. For more information on IPMI, please refer to the IPMI User's Guide posted on our website at <http://www.supermicro.com/support/manuals/>.

## 4.3 Jumpers

### *Explanation of Jumpers*

To modify the operation of the motherboard, jumpers are used to choose between optional settings. Jumpers create shorts between two pins to change the function associated with it. Pin 1 is identified with a square solder pad on the printed circuit board. See the motherboard layout page for jumper locations.

**Note:** On a two-pin jumper, "Closed" means the jumper is on both pins and "Open" indicates the jumper is either on only one pin or has been completely removed.

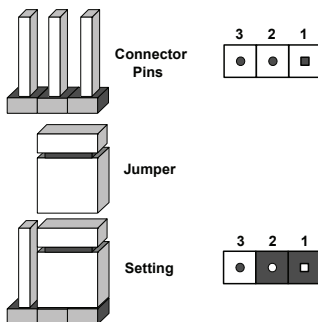

### **CMOS Clear**

JBT1 is used to clear CMOS, which will also clear any passwords. Instead of pins, this jumper consists of contact pads to prevent accidentally clearing the contents of CMOS.

#### *To Clear CMOS*

1. First power down the system and unplug the power cord.
2. Remove the cover of the chassis to access the motherboard.
3. Remove the onboard battery from the motherboard.
4. Short the CMOS pads with a metal object such as a small screwdriver for at least four seconds.
5. Remove the screwdriver (or shorting device).
6. Replace the cover, reconnect the power cords and power on the system.

**Notes:** Clearing CMOS will also clear all passwords.



## Watch Dog

JWD1 controls the Watch Dog function. The Watch Dog is a monitor that can reboot the system when a software application hangs. Jumping pins 1-2 will cause the Watch Dog to reset the system if an application hangs. Jumping pins 2-3 will generate a non-maskable interrupt signal for the application. The Watch Dog must also be enabled in the BIOS. The default setting is Reset.

**Note:** When the Watch Dog is enabled, the user needs to write their own application software to disable it.

Watch Dog Jumper Settings	
Jumper Setting	Definition
Pins 1-2	Reset (Default)
Pins 2-3	NMI
Open	Disabled

## Debug Mode Enable/Disable

Jumper JDBG1 will enable or disable Debug Mode on the motherboard. See the table below for jumper settings. The default setting is Normal Mode.

Debug Mode Enable/Disable Jumper Settings (JDBG1)	
Jumper Setting	Definition
Pins 1-2	Normal Mode (default)
Pins 2-3	Debug Mode

## 4.4 LED Indicators

### IPMI LAN Port LEDs

The IPMI Ethernet port has two LED indicators. The Activity LED is yellow and indicates connection and activity. The Link LED may be green, amber, or off to indicate the speed of the connection. Refer to the tables below for more information.

Link LED Connection Link Speed Indicator	
LED Color	Definition
Off	10 Mb/s
Green	100 Mb/s
Amber	1 Gb/s

Activity LED		
Color	State	Definition
Off	No Connection	
Yellow	Solid On	Link
Yellow	Flashing	Active

Link LED

Activity LED

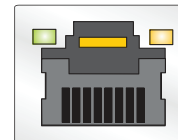

### UID Switch and LED Indicator

The rear UID LED2 is located next to the UID switch. The front UID LED is located on the front panel. When you press the UID switch, both rear and front UID LED indicators will turn on. Press the UID switch again to turn off the LED indicators. Use this UID Indicator to 'mark' the system, so the system can be easily identified whether on the front or back (e.g., a system rack with multiple units installed).

UID LED LED Indicator		
Color	State	Definition
Blue	Solid On	Unit Identified
None	Off	UID Off

### BMC Heartbeat LED

The BMC Heartbeat LED is a green LED located at BMC LED1 on the motherboard. When BMC LED1 is blinking, the BMC is functioning normally. See the table below for more information.

BMC Heartbeat LED State	
State	Definition
Solid On	BMC is not ready
Blinking	BMC Normal
Fast Blinking	BMC: Initializing

### Onboard Power OK LED

PWROK is an onboard power OK LED. When this LED is lit, it means the system is turned on, and all the system power rails are ready. When the system is turned off, or any one of the system power rails fails, this LED will turn off. Turn off the system, and unplug the power cord before removing or installing any component(s).

Onboard Power LED Indicator	
LED Color	Definition
Off	System Off (power cable not connected)
Green	System On, Power OK



## 4.5 PCI-E 4.0 Slots

### **PCI-Express 4.0 x16**

There are two PCI-E 4.0 x16 slots on the motherboard. Slot 1 and Slot 2 are supported through the riser cards. Refer to the layout in Chapter 1 for their locations.

### **PCI-Express 4.0 x8**

A PCI-E 4.0 x8 slot is located at SXB1. SXB1 is also used for SATA0~5. Refer to the layout in Chapter 1 for their location.

### **PCI-Express 4.0 x16**

A PCI-E 4.0 x16 slot is located at SXB2. Refer to the layout in Chapter 1 for the location.

### **Powered SATA DOM (SuperDOM)**

A SATA DOM (Device-on-Disk) is located at SATA6/7 on the motherboard. SATA6/7 are used with a Supermicro SuperDOM, which is a yellow SATA DOM connector with a power pin built in. No external power supply is needed. Supermicro SuperDOM is backward compatible with a regular SATA HDD or SATA DOM that requires an external power supply.

### **SIOM Networking Slot**

There is one SIOM (Super I/O Module) networking slot (PCI-E 4.0 x16 + x1) on the motherboard. See the layout in Chapter 1 for the location.

## Chapter 5

### Software

After the hardware has been installed, you can install the Operating System (OS) and drivers.

#### 5.1 Microsoft Windows OS Installation

##### *Installing the OS*

1. Create a method to access the MS Windows installation ISO file. That might be a DVD, perhaps using an external USB/SATA DVD drive, or a USB flash drive, or the IPMI KVM console.
2. Go to the Supermicro web page for your motherboard and click on "Download the Latest Drivers and Utilities", select the proper driver, and copy it to a USB flash drive.
3. Boot from a bootable device with the Windows OS installation. You can see a bootable device list by pressing **F11** during the system startup.
4. During Windows Setup, continue to the dialog where you select the drives on which to install Windows. If the disk you want to use is not listed, click on "Load driver" link at the bottom left corner.

To load the driver, browse the USB flash drive for the proper driver files.

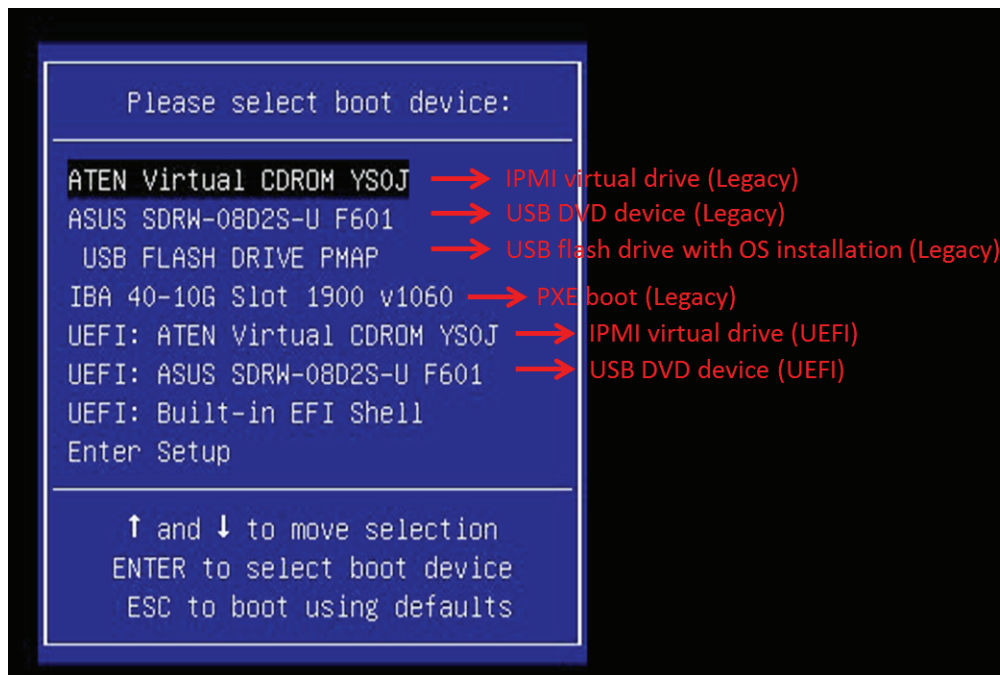
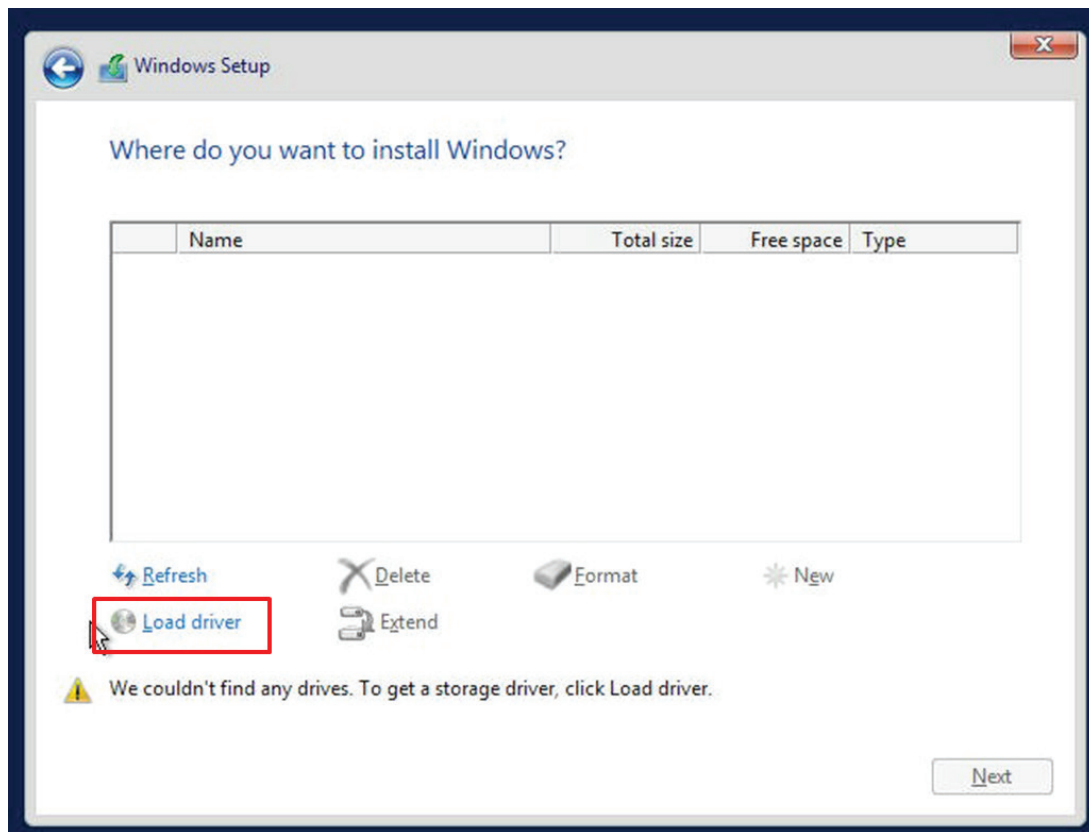

Figure 5-1. Select Boot Device

- Choose the SATA/sSATA AHCI driver indicated then choose the storage drive on which you want to install it.



**Figure 5-2. Load Driver Link**

5. Once all devices are specified, continue with the installation.
6. After the Windows OS installation has completed, the system will automatically reboot multiple times.

## 5.2 Driver Installation

The Supermicro website contains drivers and utilities for your system at [https://www.supermicro.com/support/resources/resource\\_drivers.cfm](https://www.supermicro.com/support/resources/resource_drivers.cfm).

After accessing the website, go into the CDR\_Images (in the parent directory of the above link) and locate the ISO file for your motherboard. Download this file to a USB flash drive or a DVD. (You may also use a utility to extract the ISO file if preferred.)

Another option is to go to the Supermicro website at <http://www.supermicro.com/products/>. Find the product page for your motherboard, and "Download the Latest Drivers and Utilities".

Insert the flash drive or disk and the screenshot shown below should appear.

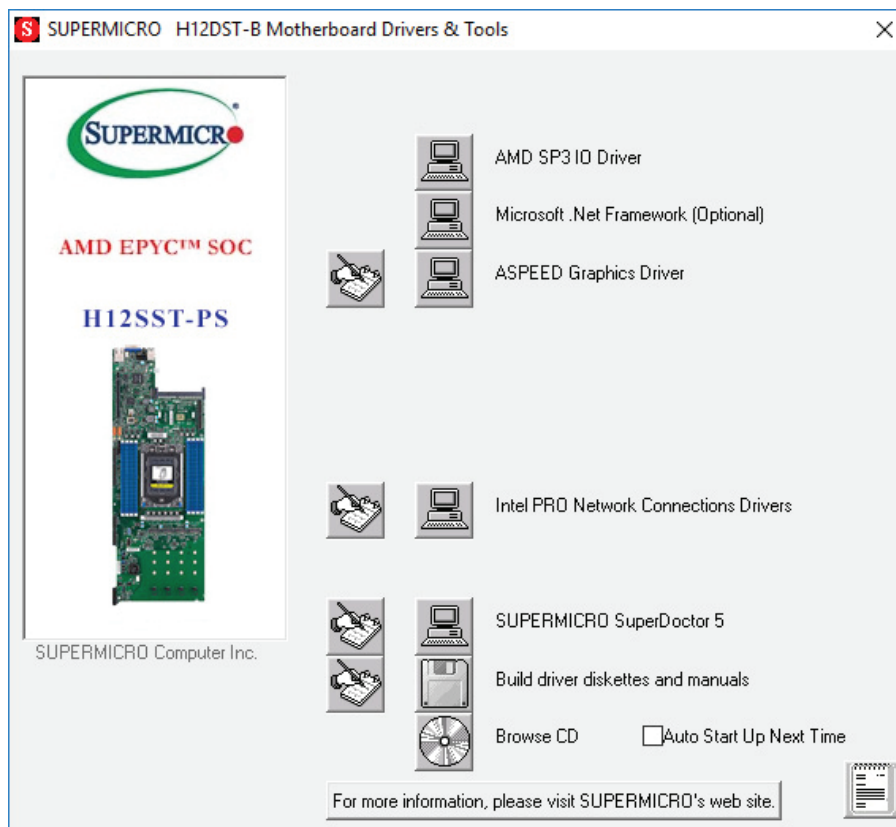

**Figure 5-3. Driver & Tool Installation Screen**

**Note:** Click the icons showing a hand writing on paper to view the readme files for each item. Click the computer icons to the right of these items to install each item (from top to the bottom) one at a time. **After installing each item, you must re-boot the system before moving on to the next item on the list.** The bottom icon with a CD on it allows you to view the entire contents.

## 5.3 SuperDoctor® 5

The Supermicro SuperDoctor 5 is a program that functions in a command-line or web-based interface for Windows and Linux operating systems. The program monitors such system health information as CPU temperature, system voltages, system power consumption, fan speed, and provides alerts via email or Simple Network Management Protocol (SNMP).

SuperDoctor 5 comes in local and remote management versions and can be used with Nagios to maximize your system monitoring needs. With SuperDoctor 5 Management Server (SSM Server), you can remotely control power on/off and reset chassis intrusion for multiple systems with SuperDoctor 5 or IPMI. SuperDoctor 5 Management Server monitors HTTP, FTP, and SMTP services to optimize the efficiency of your operation.

**Note:** The default User Name and Password for SuperDoctor 5 is ADMIN / ADMIN.

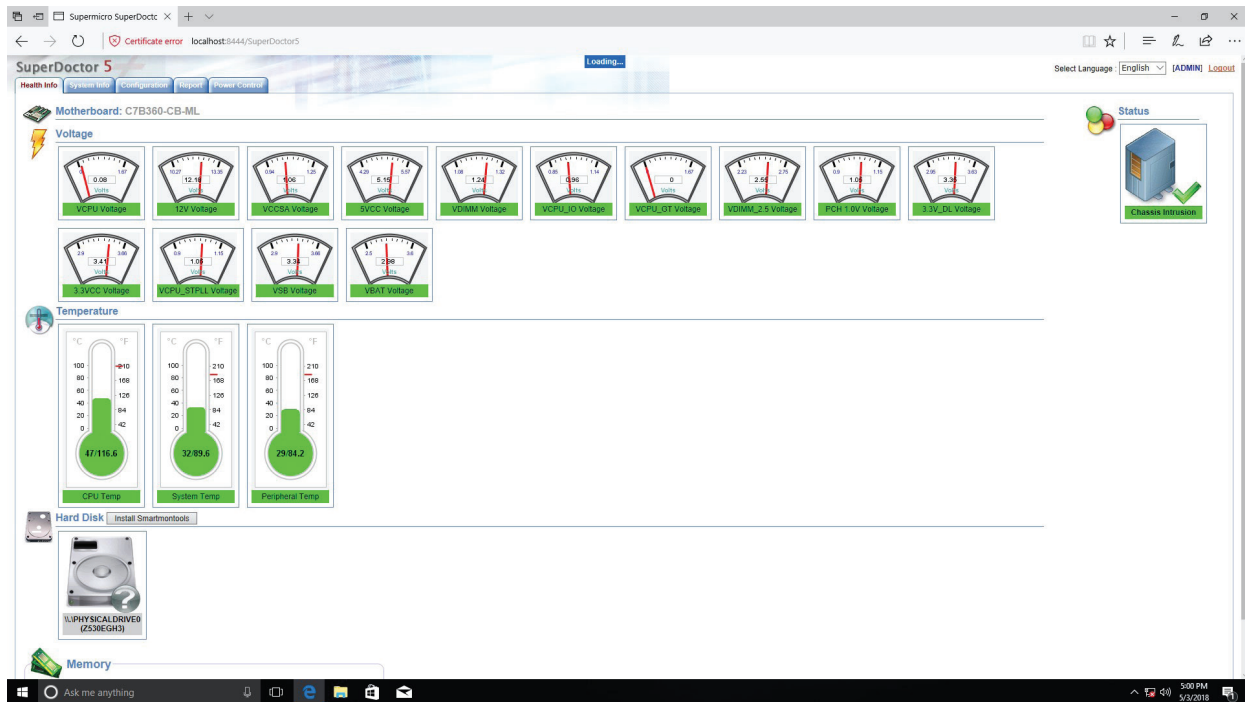

Figure 5-4. SuperDoctor 5 Interface Display Screen (Health Information)

## 5.4 IPMI

The H12SST-PS supports the Intelligent Platform Management Interface (IPMI). IPMI is used to provide remote access, monitoring and management. There are several BIOS settings that are related to IPMI.

For general documentation and information on IPMI, please visit our website at: <http://www.supermicro.com/products/nfo/IPMI.cfm>.

## Chapter 6

# UEFI BIOS

### 6.1 Introduction

This chapter describes the AMIBIOS™ Setup utility for the H12SST-PS motherboard. The BIOS is stored on a chip and can be easily upgraded using a flash program.

**Note:** Due to periodic changes to the BIOS, some settings may have been added or deleted and might not yet be recorded in this manual. Please refer to the Manual Download area of our website for any changes to BIOS that may not be reflected in this manual.

#### Starting the Setup Utility

To enter the BIOS Setup Utility, hit <Delete> while the system is booting-up. (In most cases, <Delete> is used to invoke the BIOS setup screen. There are a few cases when other keys are used, such as <F1>, <F2>, etc.) Each main BIOS menu option is described in this manual.

The Main BIOS screen has two main frames. The left frame displays all the options that can be configured. "Grayed-out" options cannot be configured. The right frame displays the key legend. Above the key legend is an area reserved for a text message. When an option is selected in the left frame, it is highlighted in white. Often a text message will accompany it. (Note that BIOS has default text messages built in. We retain the option to include, omit, or change any of these text messages.) Settings printed in **Bold** are the default values.

A "►" indicates a submenu. Highlighting such an item and pressing <Enter> will open the list of settings within that submenu.

The BIOS setup utility uses a key-based navigation system called hot keys. Most of these hot keys (<F1>, <F2>, <F3>, <Enter>, <ESC>, <Arrow> keys, etc.) can be used at any time during the setup navigation process.

## 6.2 Main Setup

When you first enter the AMI BIOS setup utility, you will enter the Main setup screen. You can always return to the Main setup screen by selecting the Main tab on the top of the screen. The Main BIOS setup screen is shown below. The following Main menu items will be displayed:

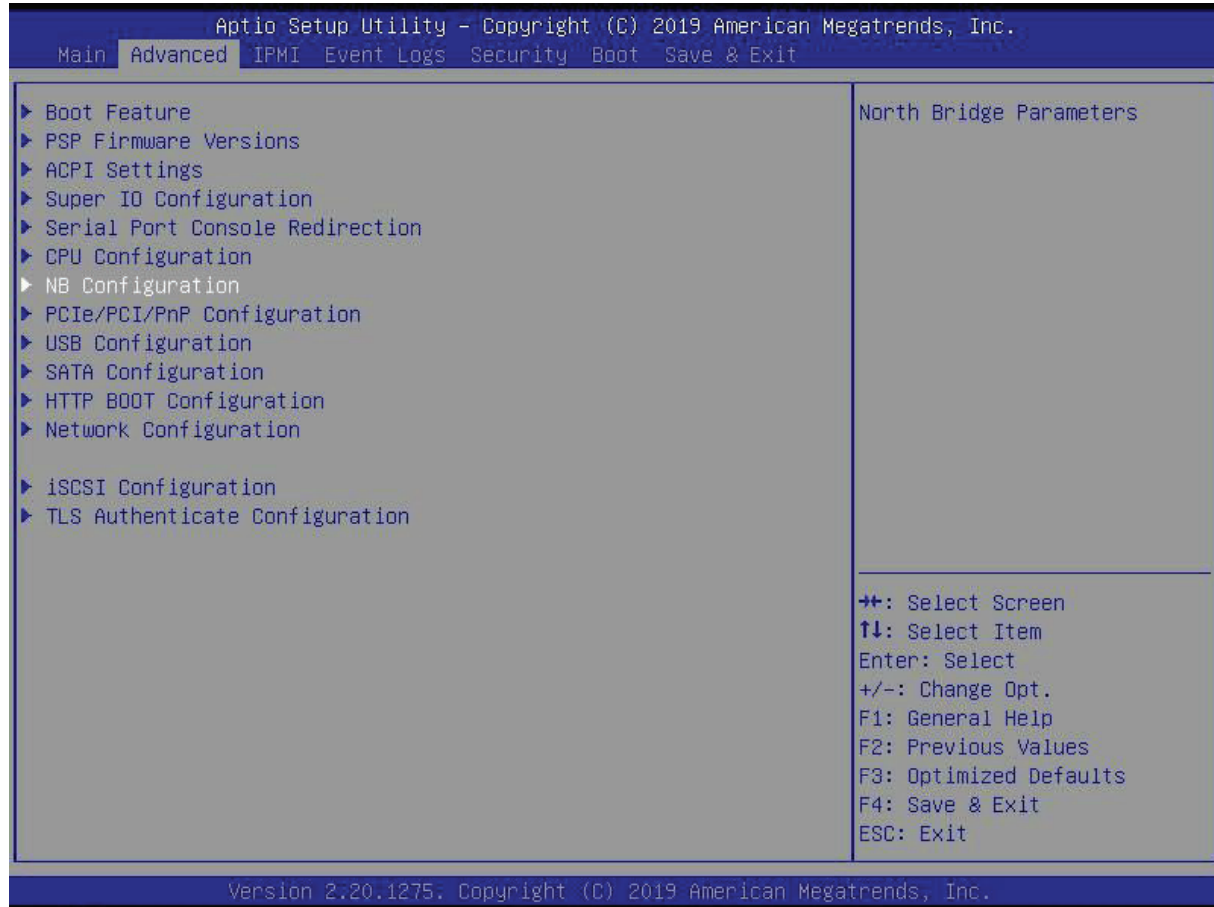

### System Date/System Time

Use this option to change the system date and time. Highlight *System Date* or *System Time* using the arrow keys. Enter new values using the keyboard. Press <Tab> or the arrow keys to move between fields. The date must be entered in MM/DD/YYYY format. The time is entered in HH:MM:SS format.

**Note:** The time is in the 24-hour format. For example, 5:30 P.M. appears as 17:30:00. The date's default value is 01/01/2015 after RTC reset.

### Supermicro H12SST-PS

#### BIOS Version

This item displays the version of the BIOS firmware used in the system.

#### Build Date

This item displays the date when the version of the BIOS firmware used in the system was built.

**CPLD Version**

This item displays the version of the CPLD firmware used in the system.

**Total Memory**

This item displays the total size of memory available in the system.



## 6.3 Advanced

Use the arrow keys to select Boot Setup and press <Enter> to access the submenu items.

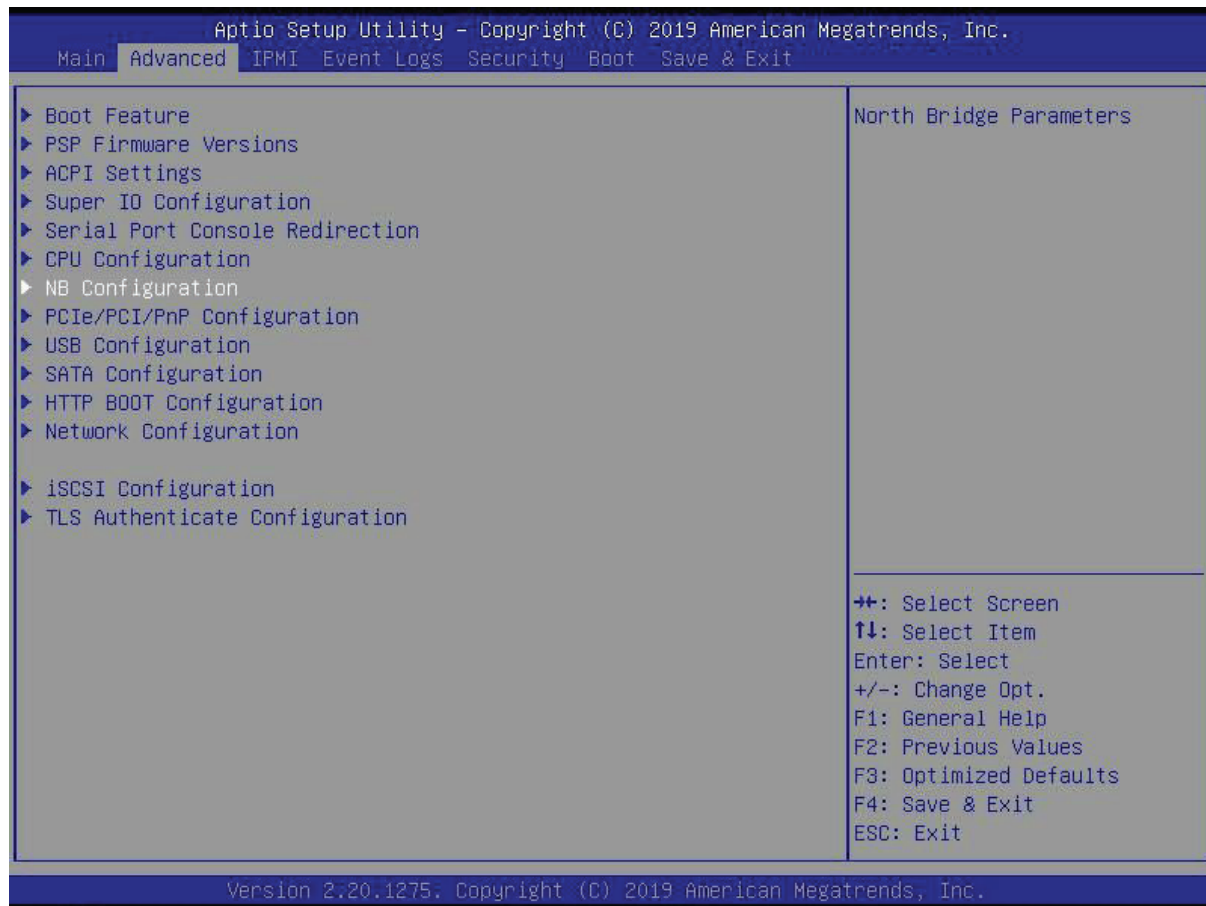

**Warning:** Take caution when changing the Advanced settings. An incorrect value, a very high DRAM frequency, or an incorrect DRAM timing setting may make the system unstable. When this occurs, revert to the default to the manufacture default settings.

### ▶ Boot Feature

#### Quiet Boot

Use this feature to select the screen display between the POST messages and the OEM logo upon bootup. Select Disabled to display the POST messages. Select Enabled to display the OEM logo instead of the normal POST messages. The options are **Enabled** and Disabled.

#### Option ROM Messages

Use this feature to set the display mode for the Option ROM. Select Keep Current to display the current AddOn ROM setting. Select Force BIOS to use the Option ROM display set by the system BIOS. The options are **Force BIOS** and Keep Current.

### **Bootup NumLock State**

Use this feature to set the Power on state for the <Numlock> key. The options are **On** and Off.

### **Wait For "F1" If Error**

Use this feature to force the system to wait until the 'F1' key is pressed if an error occurs. The options are Disabled and **Enabled**.

### **INT19 (Interrupt 19) Trap Response**

Interrupt 19 is the software interrupt that handles the boot disk function. When this item is set to Immediate, the ROM BIOS of the host adaptors will "capture" Interrupt 19 at bootup immediately and allow the drives that are attached to these host adaptors to function as bootable disks. If this item is set to Postponed, the ROM BIOS of the host adaptors will not capture Interrupt 19 immediately and allow the drives attached to these adaptors to function as bootable devices at bootup. The options are **Immediate** and Postponed.

### **Re-try Boot**

If this item is enabled, the BIOS will automatically reboot the system from a specified boot device after its initial boot failure. The options are **Disabled**, Legacy Boot, and EFI Boot.

### **Power Configuration**

#### **Watch Dog Function**

If enabled, the Watch Dog Timer will allow the system to reset or generate NMI based on jumper settings when it is expired for more than 5 minutes. The options are **Disabled** and Enabled.

#### **Restore on AC Power Loss**

Use this feature to set the power state after a power outage. Select Stay-Off for the system power to remain off after a power loss. Select Power-On for the system power to be turned on after a power loss. Select Last State to allow the system to resume its last power state before a power loss. The options are Stay Off, Power On, and **Last State**.

#### **Power Button Function**

This feature controls how the system shuts down when the power button is pressed. Select 4 Seconds Override for the user to power off the system after pressing and holding the power button for 4 seconds or longer. Select Instant Off to instantly power off the system as soon as the user presses the power button. The options are **Instant Off** and 4 Seconds Override.

## ►PSP Firmware Versions

This section displays the Platform Security Processor (PSP) firmware versions.

### PSP Directory Level 1 (Fixed)

- PSP Recovery BL Ver
- SMU FW Version
- ABL Version
- APCB Version
- APOB Version
- APPB Version

### PSP Directory Level 2 (Updateable)

- PSP Bootloader Version
- SMU FW Version
- ABL Version
- APCB Version
- APOB Version
- APPB Version

## ►ACPI Settings

### High Precision Event Tmber

The options are Disabled and **Enabled**.

### NUMA nodes per socket

The options are NPS0, NPS1, NPS2, NPS4 and **Auto**.

## ►Super IO Configuration

### Super IO Chip

#### Serial Port 1 Configuration

##### Serial Port

The options are Disabled and **Enabled**.

##### Device Settings

This item displays the status of a serial part specified by the user.

### Change Settings

The options are **Auto**, IO=3F8h; IRQ=4; IO=3F8h; IRQ=3,4,5,6,7,9,10,11,12; IO=2F8h; IRQ=3,4,5,6,7,9,10,11,12; IO=3E8h; IRQ=3,4,5,6,7,9,10,11,12; IO=2E8h; IRQ=3,4,5,6,7,9,10,11,12;

### Sol Configurationf

#### Serial Port

The options are Disabled and **Enabled**.

#### Device Settings

This item displays the status of a device specified by the user.

### Change Settings

The options are **Auto**, IO=2F8h; IRQ=3; IO=3F8h; IRQ=3,4,5,6,7,9,10,11,12; IO=2F8h; IRQ=3,4,5,6,7,9,10,11,12; IO=3E8h; IRQ=3,4,5,6,7,9,10,11,12; IO=2E8h; IRQ=3,4,5,6,7,9,10,11,12;

## ► Serial Port Console Redirection

### COM1

#### Console Redirection

Select Enabled to enable console redirection support for a serial port specified by the user. The options are **Disabled** and Enabled.

*\*If the item above set to Enabled, the following items will become available for user's configuration:*

#### Console Redirection Settings

##### Terminal Type

This feature allows the user to select the target terminal emulation type for Console Redirection. Select VT100 to use the ASCII Character set. Select VT100+ to add color and function key support. Select ANSI to use the Extended ASCII Character Set. Select VT-UTF8 to use UTF8 encoding to map Unicode characters into one or more bytes. The options are VT100, **VT100+**, VT-UTFB and ANSI.

##### Bits per second

Use this feature to set the transmission speed for a serial port used in Console Redirection. Make sure that the same speed is used in the host computer and the client computer. A lower transmission speed may be required for long and busy lines. The options are 9600, 19200, 38400, 57600 and **115200** (bits per second).

**Data Bits**

Use this feature to set the data transmission size for Console Redirection. The options are 7 and 8.

**Parity**

A parity bit can be sent along with regular data bits to detect data transmission errors. Select Even if the parity bit is set to 0, and the number of 1's in data bits is even. Select Odd if the parity bit is set to 0, and the number of 1's in data bits is odd. Select None if you do not want to send a parity bit with your data bits in transmission. Select Mark to add a mark as a parity bit to be sent along with the data bits. Select Space to add a Space as a parity bit to be sent with your data bits. The options are **None**, Even, Odd, Mark and Space.

**Stop Bits**

A stop bit indicates the end of a serial data packet. Select 1 Stop Bit for standard serial data communication. Select 2 Stop Bits if slower devices are used. The options are 1 and 2.

**Flow Control**

Use this feature to set the flow control for Console Redirection to prevent data loss caused by buffer overflow. Send a "Stop" signal to stop sending data when the receiving buffer is full. Send a "Start" signal to start sending data when the receiving buffer is empty. The options are **None** and Hardware RTS/CTS.

**VT-UTFB Combo Key Support**

Select Enabled to enable VT-UTF8 Combination Key support for ANSI/VT100 terminals. The options are Disabled and **Enabled**.

**Recorder Mode**

Select Enabled to capture the data displayed on a terminal and send it as text messages to a remote server. The options are **Disabled** and Enabled.

**Resolution 100x31**

Select Enabled for extended-terminal resolution support. The options are Disabled and **Enabled**.

**Putty KeyPad**

This feature selects the settings for Function Keys and KeyPad used for Putty, which is a terminal emulator designed for the Windows OS. The options are **VT100**, LINUX, XTERMR6, SC0, ESCN and VT400.

## SOL

### Console Redirection

Select Enabled to enable SOL console redirection support for a serial port specified by the user. The options are **Disabled** and Enabled.

***\*If the item above set to Enabled, the following items will become available for user's configuration:***

### Console Redirection Settings

#### Terminal Type

This feature allows the user to select the target terminal emulation type for Console Redirection. Select VT100 to use the ASCII Character set. Select VT100+ to add color and function key support. Select ANSI to use the Extended ASCII Character Set. Select VT-UTF8 to use UTF8 encoding to map Unicode characters into one or more bytes. The options are VT100, **VT100+**, VT-UTFB and ANSI.

#### Bits per second

Use this feature to set the transmission speed for a serial port used in Console Redirection. Make sure that the same speed is used in the host computer and the client computer. A lower transmission speed may be required for long and busy lines. The options are 9600, 19200, 38400, 57600 and **115200** (bits per second).

#### Data Bits

Use this feature to set the data transmission size for Console Redirection. The options are 7 and **8**.

#### Parity

A parity bit can be sent along with regular data bits to detect data transmission errors. Select Even if the parity bit is set to 0, and the number of 1's in data bits is even. Select Odd if the parity bit is set to 0, and the number of 1's in data bits is odd. Select None if you do not want to send a parity bit with your data bits in transmission. Select Mark to add a mark as a parity bit to be sent along with the data bits. Select Space to add a Space as a parity bit to be sent with your data bits. The options are **None**, Even, Odd, Mark and Space.

#### Stop Bits

A stop bit indicates the end of a serial data packet. Select 1 Stop Bit for standard serial data communication. Select 2 Stop Bits if slower devices are used. The options are **1** and 2.

#### Flow Control

Use this feature to set the flow control for Console Redirection to prevent data loss caused by buffer overflow. Send a "Stop" signal to stop sending data when the receiving buffer is full. Send a "Start" signal to start sending data when the receiving buffer is empty. The options are **None** and Hardware RTS/CTS.

**VT-UTFB Combo Key Support**

Select Enabled to enable VT-UTF8 Combination Key support for ANSI/VT100 terminals. The options are Disabled and **Enabled**.

**Recorder Mode**

Select Enabled to capture the data displayed on a terminal and send it as text messages to a remote server. The options are **Disabled** and Enabled.

**Resolution 100x31**

Select Enabled for extended-terminal resolution support. The options are Disabled and **Enabled**.

**Putty KeyPad**

This feature selects the settings for Function Keys and KeyPad used for Putty, which is a terminal emulator designed for the Windows OS. The options are **VT100**, LINUX, XTERMR6, SC0, ESCN and VT400.

**Legacy Console Redirection****Legacy Console Redirection Settings****Redirection COM Port**

For this setting, select a COM port to display redirection of Legacy OS and Legacy OPROM messages. The options are **COM1** and SOL.

**Resolution**

For Legacy OS systems, use this setting to specify the number of Rows and Columns supported for redirection. The options are **80x24** and 80x25.

**Redirect After POST**

For this setting, when the Bootloader is selected, then the Legacy Console Redirection is disabled before booting to the legacy OS. If you select Always Enable, then the Legacy Console Redirection is enabled for legacy OS systems. The options are **Always Enable** and BootLoader.

**Serial Port for Out-of-Band Management/Windows Emergency Management Services (EMS)****Console Redirection**

Select Enabled to enable EMS console redirection support for a serial port specified by the user. The options are **Disabled** and Enabled.

*\*If the item above set to Enabled, the following items will become available for user's configuration:*

► **Console Redirection Settings**

**Out-of-Band Mgmt Port**

The feature selects a serial port in a client server to be used by the Microsoft Windows Emergency Management Services (EMS) to communicate with a remote host server. The options are **COM1** and SOL.

**Terminal Type**

Use this feature to select the target terminal emulation type for Console Redirection. Select VT100 to use the ASCII character set. Select VT100+ to add color and function key support. Select ANSI to use the extended ASCII character set. Select VT-UTF8 to use UTF8 encoding to map Unicode characters into one or more bytes. The options are VT100, VT100+, **VT-UTF8**, and ANSI.

**Bits per second**

This item sets the transmission speed for a serial port used in Console Redirection. Make sure that the same speed is used in the host computer and the client computer. A lower transmission speed may be required for long and busy lines. The options are 9600, 19200, 57600, and **115200** (bits per second).

**Flow Control**

Use this item to set the flow control for Console Redirection to prevent data loss caused by buffer overflow. Send a "Stop" signal to stop sending data when the receiving buffer is full. Send a "Start" signal to start sending data when the receiving buffer is empty. The options are **None**, Hardware RTS/CTS, and Software Xon/Xoff.

**Data Bits**

Use this feature to set the data transmission size for Console Redirection. The options are 7 and **8**.

**Parity**

A parity bit can be sent along with regular data bits to detect data transmission errors. Select Even if the parity bit is set to 0, and the number of 1's in data bits is even. Select Odd if the parity bit is set to 0, and the number of 1's in data bits is odd. Select None if you do not want to send a parity bit with your data bits in transmission. Select Mark to add a mark as a parity bit to be sent along with the data bits. Select Space to add a Space as a parity bit to be sent with your data bits. The options are **None**, Even, Odd, Mark and Space.



### Stop Bits

A stop bit indicates the end of a serial data packet. Select 1 Stop Bit for standard serial data communication. Select 2 Stop Bits if slower devices are used. The options are **1** and **2**.

## ► CPU Configuration

### SMT Control

Use this setting to specify Simultaneous Multithreading. Options include Disabled for 1T single thread and **Auto** for 2T two-thread if your system is capable of it.

### Core Performance Boost

This setting is used to configure for Core Performance Boost. Options include Disabled and **Auto**.

### Global C-state Control

This setting is used to configure for Global C-state Control. Options include Disabled, Enabled and **Auto**.

### Core Control

This sets the number of cores to be used by your system. Once this option has been used to remove any cores, a power cycle is required in order for the future selections to take effect. Options include **Auto**, TWO (1+1), Four (2 + 2) and Six (3 + 3). If unsure, leave this to Auto.

### L1 Stream HW Prefetcher / L2 Stream HW Prefetcher

This setting is used to enable or disable the L1/L2 Stream Hardware Prefetcher. The options are Disabled, Enabled and **Auto**.

### SVM Mode

This setting enables or disables CPU Virtualization. The options are Disabled and **Enabled**.

### SMEE

This setting enables or disables secure memory encryption control. The options are **Disabled** and Enabled.

## ► CPU1 Information

These sections are for informational purposes. They will display some details about the detected CPUs on the motherboard, such as:

- CPU Version
- Number of Cores Running
- Clock speed
- Processor Family

- Processor Model
- Microcode Patch Level
- L1 Instruction Cache (Size/Method)
- L1 Data Cache (Size/Method)
- L2 Cache (Size/Method)
- L3 Cache per Socket (Size/Method)

## ►NB Configuration

### Determinism Slider

Use this setting to configure the Determinism Slider. Options include **Auto**, Power and Performance.

### cTDP Control

Use this setting to configure the cTDP Control. Options include **Manual** and Auto.

### cTDP

Option include 240.

### IOMMU

Use this setting to enable/disable IOMMU. Options include **Disabled**, Enabled, and Auto.

### ACS Enable

Use this setting to enable/disable ACS. Options include Enabled, Disabled and **Auto**.

## ►Memory Configuration

### Memory Clock

This setting allows you to select different memory clock speed. The options include **Auto** and speed settings.

### Memory Interleaving

This setting controls fabric level memory interleaving. Note that the channel, die and socket have requirements on memory populations and it will be ignored if the memory doesn't support the selected option. The options include Disabled and **Auto**.

### Memory Interleaving Size

This setting controls the memory interleaving size. This determines the starting address of the interleave (bit 8, 9, 10 or 11). The options include 256 Bytes, 512 Bytes, 1 KB, 2 KB or **Auto**.

### **Chipselect Interleaving**

This setting controls interleave memory blocks across the DRAM chip for node 0. The options are Disabled and **Auto**.

### **BankGroupSwap**

This setting controls the Bank Group Swap. The options are Enabled, Disabled and **Auto**.

### **► CPU1 Memory Information**

These sections are for informational purposes. They will display some details about the detected memory according to each CPU on the motherboard, such as:

- Detected Size (per slot, in MB)
- Current Speed (MT/s)

### **► PCIe/PCI/PnP Configuration**

This menu provides PCIe/PCI/PnP configuration settings and information.

#### **PCI Devices Common Settings**

##### **Above 4G Decoding**

This setting enables or disables 64-bit capable devices ability to be decoded in above 4G address space (only if the system supports 64-bit PCI decoding). The options are Disabled and **Enabled**.

##### **SR-IOV Support**

If the system has SR-IOV capable PCI-E devices, this setting will enable or disable the Single Root IO Virtualization Support for the system. The options are **Disabled** and Enabled.

##### **BME DMA Mitigation**

Use this setting to re-enable the Bus Master Attribute that was disabled during PCI enumeration for PCI bridges after SMM is locked. The options are **Disabled** and Enabled.

##### **ARI Forwarding**

If supported by the hardware and set to 'enabled', the downstream port disables its traditional device number field, being 0 enforcement, when turning a type1 configuration request into a type0 configuration request. This permits access to extended functions in an ARI device immediately below the port. The options are **Disabled** and Enabled.

##### **PCIe Spread Spectrum**

Use this setting to enable or disable PCI-E Spread Spectrum for your system. The options are **Disabled** and Enabled.

### **Target Link Speed**

If supported by hardware and set to Force to x.S GT/S (x being a value of 2.5, 5.0 or 8.0) for Downstream Ports, this sets an upper limit on Link Operational Speed by restricting the values advertised by the UPstream component in its training sequences. When Auto is selected, the HW initialized data will be used. The options are **Auto**, Force to 2.5 GT/s, Force to 5.0 GT/s, Force to 8.0 and Force to 16.0 GT/s.

### **VGA Priority**

Use this setting to select between onboard or offboard VGA support. The options are **Onboard** and Offboard.

### **NVMe Firmware Source**

Use this setting to select between the AMI Native firmware support or the device vendor-defined firmware support. The options are **Vendor Defined Firmware** and AMI Native Support.

### **M.2(AHCI) Firmware Source**

Use this setting to select between the AMI Native firmware support or the device vendor-defined firmware support. The options are **Vendor Defined Firmware** and AMI Native Support.

### **M.2 HC1 PCI-E 4.0x4 OPROM**

This setting enables or disables the listed PCI-E Slot OPROM option. The options are Disabled, **Legacy** and EFI.

### **M.2 HC2 PCI-E 4.0x4 OPROM**

This setting enables or disables the listed PCI-E Slot OPROM option. The options are Disabled, **Legacy** and EFI.

### **M.2 HC3 PCI-E 4.0x4 OPROM**

This setting enables or disables the listed PCI-E Slot OPROM option. The options are Disabled, **Legacy** and EFI.

### **M.2 HC4 PCI-E 4.0x4 OPROM**

This setting enables or disables the listed PCI-E Slot OPROM option. The options are Disabled, **Legacy** and EFI.

### **RSC-PR-6-X2 SLOT1 PCI-E 4.0x16 OPROM**

The options are Disabled, **Legacy** and EFI.

### **RSC-P-6-X2 SLOT1 PCI-E 4.0x16 OPROM**

The options are Disabled, **Legacy** and EFI.

**Onboard LAN1 Option ROM**

Use this setting to select which option ROM is to be loaded for onboard LAN1 on the system. The options are Disabled, **Legacy** and EFI.

**Onboard LAN2 Option ROM**

Use this setting to select which option ROM is to be loaded for onboard LAN2 on the system. The options are **Disabled** and PXE.

**Onboard LAN3 Option ROM**

Use this setting to select which option ROM is to be loaded for onboard LAN3 on the system. The options are **Disabled** and PXE.

**Onboard LAN4 Option ROM**

Use this setting to select which option ROM is to be loaded for onboard LAN4 on the system. The options are **Disabled** and PXE.

**►USB Configuration****USB Configuration****USB Module Version****USB Controllers****USB Devices****Legacy USB Support**

Select Enabled to support onboard legacy USB devices. Select Auto to disable legacy support if there are no legacy USB devices present. Select Disable to have all USB devices available for EFI applications only. The options include Enabled, Disabled and Auto.

**XHCI Hand-off**

This is a work-around solution for operating systems that do not support XHCI (Extensible Host Controller Interface) hand-off. The XHCI ownership change should be claimed by the XHCI driver. The options include **Enabled** and Disabled.

**USB Mass Storage Driver Support**

This setting will enable or disable support for USB mass storage drivers. The options include Disabled and **Enabled**.

### **Port 60/64 Emulation**

Select Enabled for I/O port 60h/64h emulation support, which in turn, will provide complete legacy USB keyboard support for the operating systems that do not support legacy USB devices. The options include Disabled and **Enabled**.

### **►SATA Configuration**

This section displays the detected SATA devices installed on the system.

#### **SATA Enable**

This item enables or disables the onboard SATA controller supported by the Intel PCH chip. The options include Disabled, Enabled and **Auto**.

#### **SATA Hotplug**

This item enables or disables the onboard SATA controller's hot plug feature (PCH). The options include Disabled and **Enabled**.

#### **SATA Information**

This item displays information on the detected SATA devices connected and are detected.

### **►HTTP BOOT Configuration**

#### **HTTP Boot One Time**

When the HTTP boot option is created, this option when enabled, will allow the system to boot via HTTP the first time and revert to the default boot after. The options include **Disabled** and Enabled.

#### **Input the description**

This option is an input field that, when the HTTP boot option is created, can be used to enter text to describe or identify the HTTP connection.

#### **Boot URI**

This option is an input field used to enter a web or network address to point to the HTTP boot files. This supports the HTTP or HTTPS protocols only.

## ▶ Network Configuration (Available when EFI is selected in LAN OPROM after reboot.)

### ▶ iSCSI Configuration

#### iSCSI Initiator Name

This feature allows the user to enter the unique name of the iSCSI Initiator in IQN format. Once the name of the iSCSI Initiator is entered into the system, configure the proper settings for the following items.

#### ▶ Add an Attempt

#### ▶ Delete Attempts

#### ▶ Change Attempt Order

### ▶ TLS Authenticate Configuration

This submenu allows the user to configure Transport Layer Security (TLS) settings.

#### ▶ Server CA Configuration

#### ▶ Enroll Certification

##### Enroll Certification using File

Use this feature to enroll certification from a file.

##### Certification GUID

Use this feature to input the certification GUID.

##### Commit Changes and Exit

Use this feature to save all changes and exit TLS settings.

##### Discard Changes and Exit

Use this feature to discard all changes and exit TLS settings.

#### ▶ Delete Certification

Use this feature to delete certification. The options include **Disabled** and **Enabled**.

## 6.4 IPMI

This tab allows you to configure the following IPMI settings for the system.

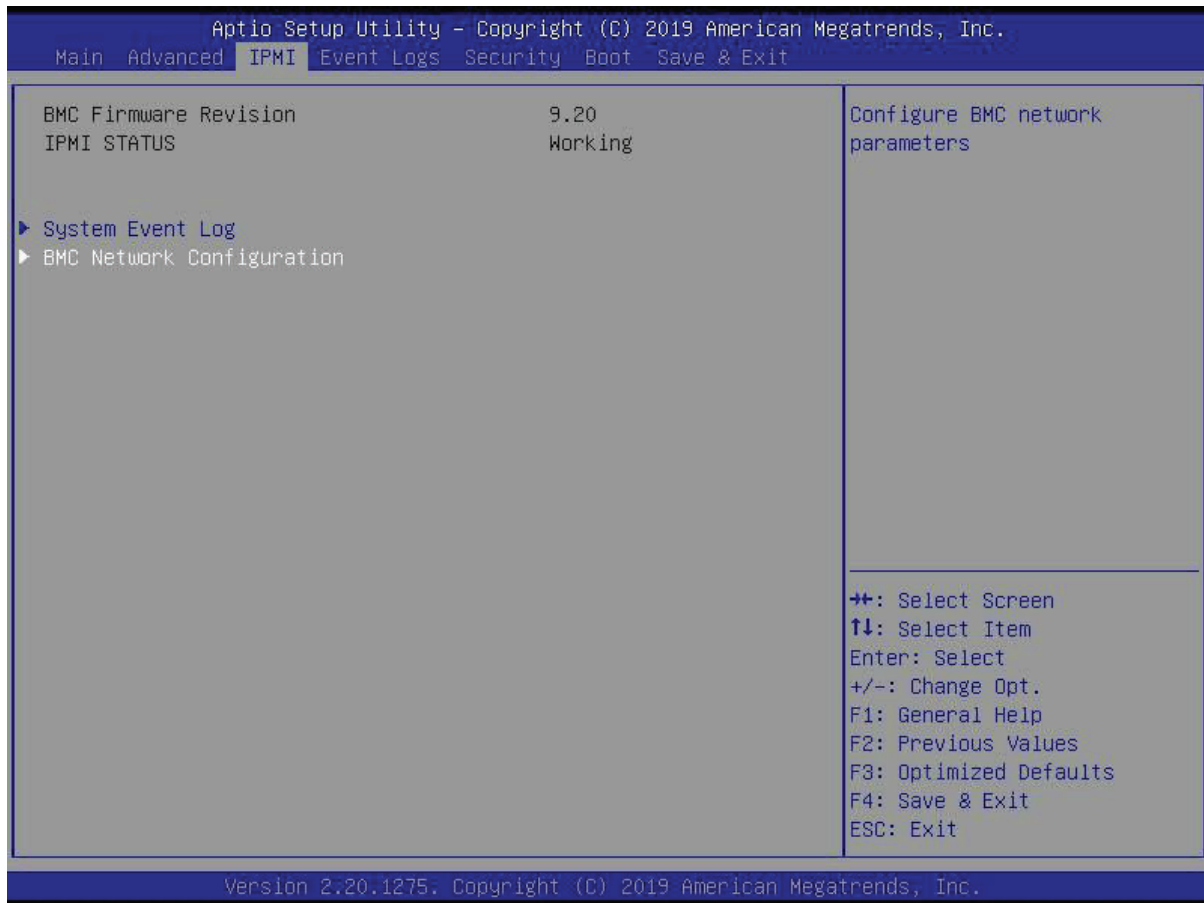

Use this feature to configure Intelligent Platform Management Interface (IPMI) settings.

### BMC Firmware Revision

This item indicates the IPMI firmware revision used in your system.

### IPMI Status

This item indicates the status of the IPMI firmware installed in your system.

### ▶ System Event Log

#### Enabling/Disabling Options

#### SEL Components

Select Enabled for all system event logging at bootup. The options are Disabled and **Enabled**.



## Erasing Settings

### Erase SEL

Select Yes, On next reset to erase all system event logs upon next system reboot. Select Yes, On every reset to erase all system event logs upon each system reboot. Select No to keep all system event logs after each system reboot. The options are **No**, Yes, On next reset, and Yes, On every reset.

### When SEL is Full

This feature allows the user to decide what the BIOS should do when the system event log is full. Select Erase Immediately to erase all events in the log when the system event log is full. The options are **Do Nothing** and Erase Immediately.

**Note:** After making changes on a setting, be sure to reboot the system for the changes to take effect.

## ► BMC Network Configuration

### BMC Network Configuration

#### Update IPMI LAN Configuration

Select Yes for the BIOS to implement all IP/MAC address changes at the next system boot. The options are **No** and Yes.

#### Configure IPV4 Support

This section displays static configuration features for IPV4 support.

#### IPMI LAN Selection

This item displays the IPMI LAN setting. The default setting is **Failover**.

#### IPMI Network Link Status

This item displays the IPMI Network Link status. The default setting is **Dedicated LAN**.

***\*If the item above is set to Yes, the following item will become available for configuration:***

#### Configuration Address Source

This feature allows the user to select the source of the IP address for this computer. If Static is selected, you will need to know the IP address of this computer and enter it to the system manually in the field. If DHCP is selected, the BIOS will search for a DHCP (Dynamic Host Configuration Protocol) server in the network that is attached to and request the next available IP address for this computer. The options are Static and **DHCP**.

***\*If the item above is set to Static, the following items will become available for configuration:***

### **Station IP Address**

This item displays the Station IP address for this computer. This should be in decimal and in dotted quad form.

### **Subnet Mask**

This item displays the sub-network that this computer belongs to. The value of each three-digit number separated by dots should not exceed 255.

### **Gateway IP Address**

This item displays the Gateway IP address for this computer. This should be in decimal and in dotted quad form (i.e., 172.31.0.1).

### **VLAN**

This item configures the virtual LAN settings. The options are **Disabled** and Enable.

## **Configure IPV6 Support**

This section displays configuration features for IPV6 support.

### **IPV6 Support**

Use this feature to enable IPV6 support. The options are **Enabled** and Disabled.

### **Configuration Address Source**

This feature allows the user to select the source of the IP address for this computer. If Static is selected, you will need to know the IP address of this computer and enter it to the system manually in the field. If DHCP is selected, the BIOS will search for a DHCP (Dynamic Host Configuration Protocol) server in the network that is attached to and request the next available IP address for this computer. The options are Static and **DHCP**.

***\*If the item "Configuration Address Source" above is set to Static, the following items will become available for configuration:***

- Station IPV6 Address
- Prefix Length
- IPV6 Router1 IP Address

## 6.5 Event Logs

This tab allows the user to configure the following event logs settings for the system.

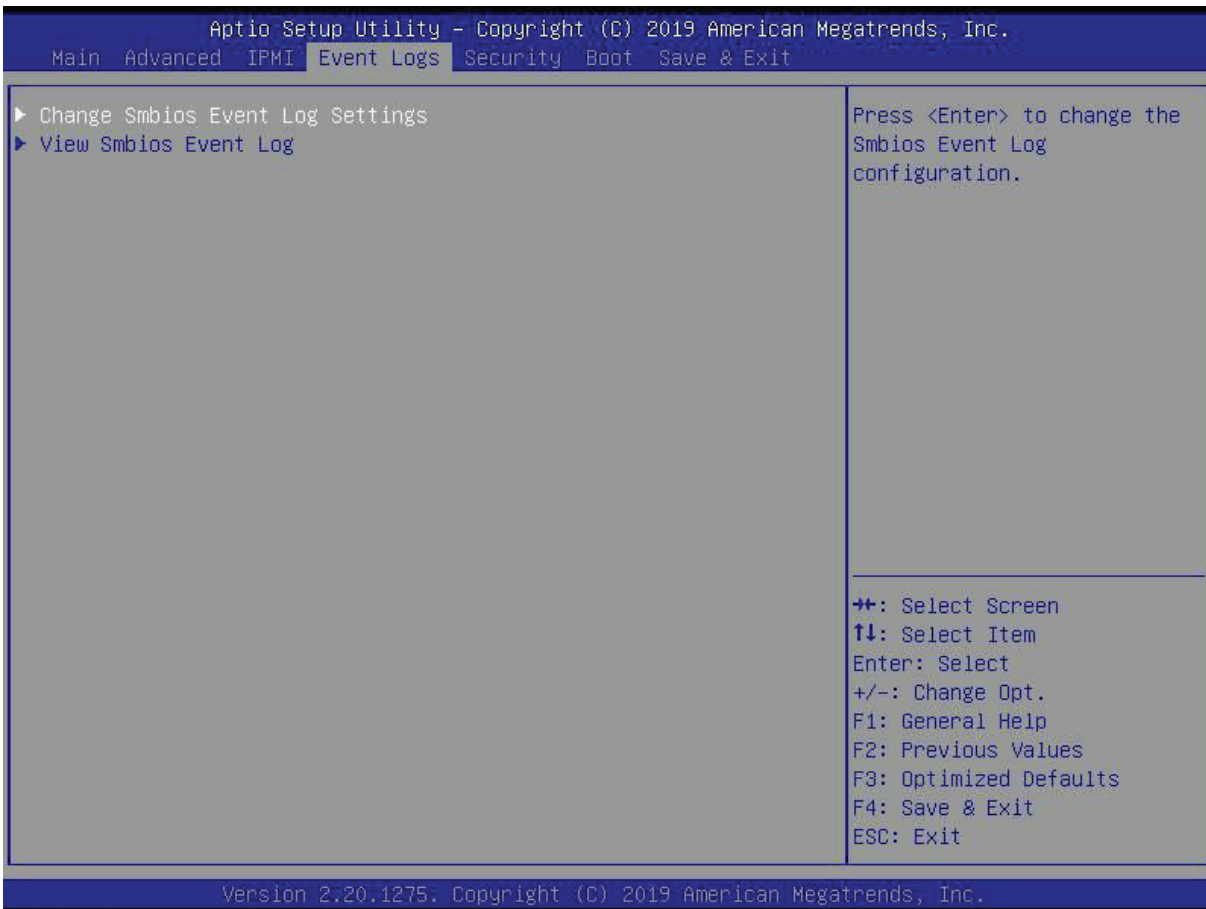

### ► Change SMBIOS Event Log Settings

This feature allows the user to configure SMBIOS Event settings.

#### Enabling/Disabling Options

##### SMBIOS Event Log

Select Enabled to enable SMBIOS (System Management BIOS) Event Logging during system boot. The options are Disabled and **Enabled**.

#### Erasing Settings

##### Erase Event Log

Select Yes to erase all error events in the SMBIOS (System Management BIOS) log before an event logging is initialized at bootup. The options are **No**, Yes, Next reset, and Yes, Every reset.

### **When Log is Full**

Select Erase Immediately to immediately erase all errors in the SMBIOS event log when the event log is full. Select Do Nothing for the system to do nothing when the SMBIOS event log is full. The options are **Do Nothing** and Erase Immediately.

### **SMBIOS Event Log Standard Settings**

#### **Log System Boot Event**

Select Enabled to log system boot events. The options are Enabled and **Disabled**.

#### **MECI (Multiple Event Count Increment)**

Enter the increment value for the multiple event counter. Enter a number between 1 to 255. The default setting is 1.

#### **METW (Multiple Event Count Time Window)**

This item is used to determine how long (in minutes) the multiple event counter should wait before generating a new event log. Enter a number between 0 to 99. The default setting is **60**.

**Note:** Please reboot the system for these changes to take effect.

### **►View Smbios Event Log**

When Event Logging is on, this item allows the user to view the entries in the SMBIOS event log. The following categories are displayed:

**Date/Time/Error Code/Severity**

## 6.6 Security

This tab allows you to configure the following security settings for the system.

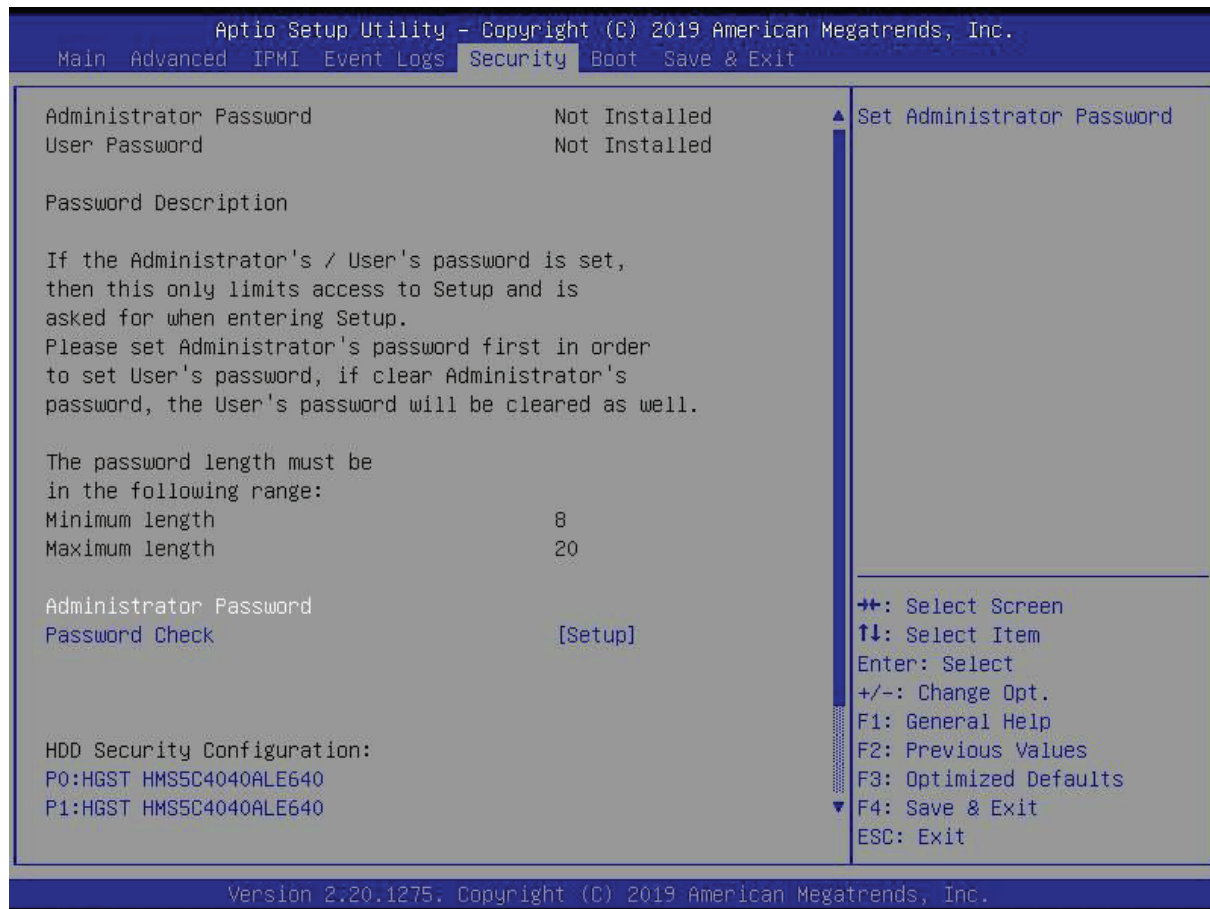

### Administrator Password

Press <Enter> to create a new, or change an existing Administrator password. Note that if the Administrator Password is erased, the User Password will be cleared as well.

### Password Check

Select Setup for the system to check for a password at Setup. Select Always for the system to check for a password at bootup or upon entering the BIOS Setup utility. The options are **Setup** and **Always**.

## 6.7 Boot

Use this tab to configure Boot Settings:

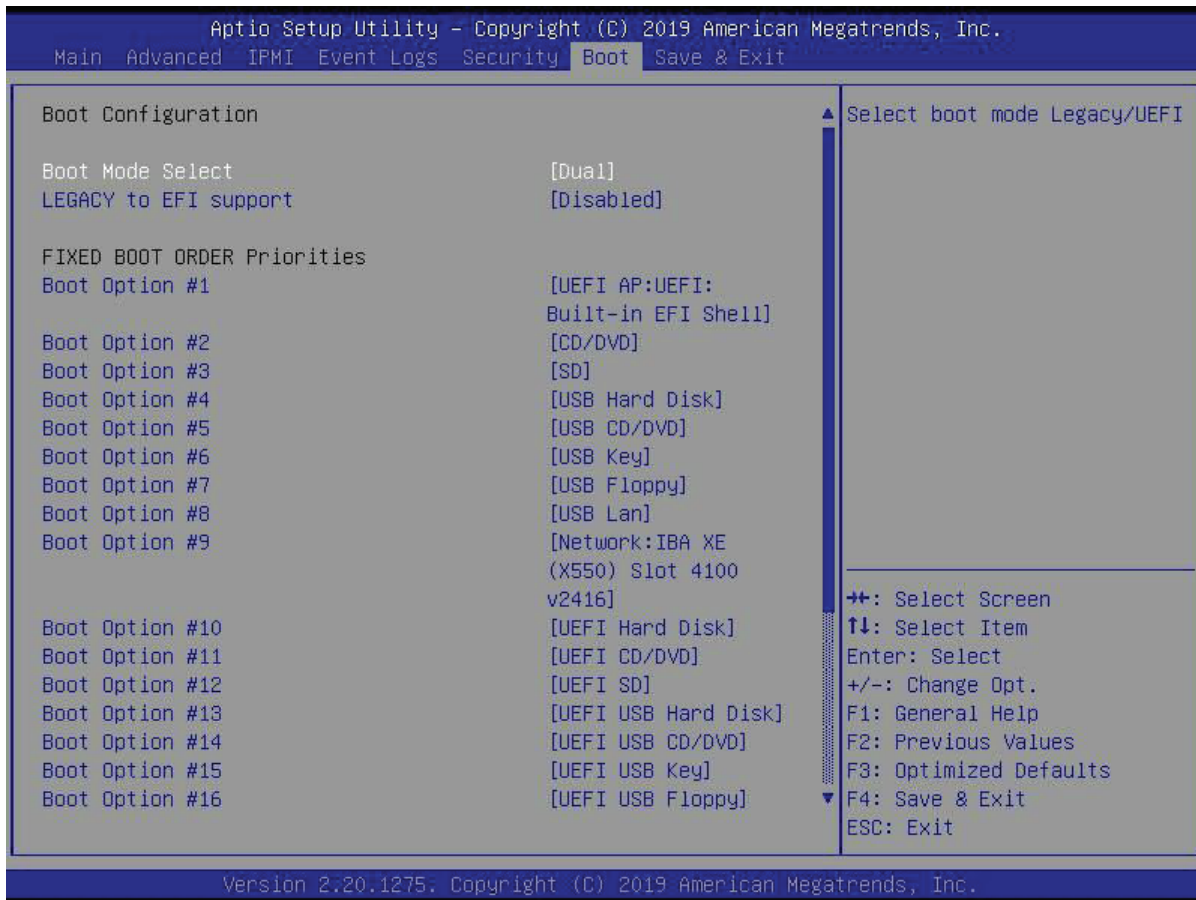

### Boot Mode Select

Use this item to select the type of device that the system is going to boot from. The options are Legacy, UEFI, and **Dual**.

### Legacy to EFI Support

This option enables or disables the system to boot to an EFI OS after the boot failed from the legacy boot order. The options include **Disabled** and Enabled.

### FIXED BOOT ORDER Priorities Section

This option prioritizes the order of bootable devices that the system to boot from. Press <Enter> on each entry from top to bottom to select devices.

### ► Add New Boot Option

Use this feature to configure the following settings when adding a new device to the boot priority list.

**Add boot option****Path for boot option****Boot Option File Path****Create****►Delete Boot Option**

Use this feature to remove a pre-defined boot device from which the system will boot during startup. The options include **Select one to Delete**, UEFI: Built-in EFI Shell and Windows Boot Manager (SATA SSD).

**►UEFI Application Boot Priorities**

Use this feature to specify which UEFI devices are boot devices.

- Boot Order #1

**►Hard Disk Drive BBS Priorities**

Use this feature to specify which hard disk drive devices are boot devices.

**►NETWORK Drive BBS Priorities**

This feature allows the user to specify which network drive devices are boot devices.

## 6.8 Save & Exit

Select the Save & Exit tab to enter the Save & Exit BIOS Setup screen.

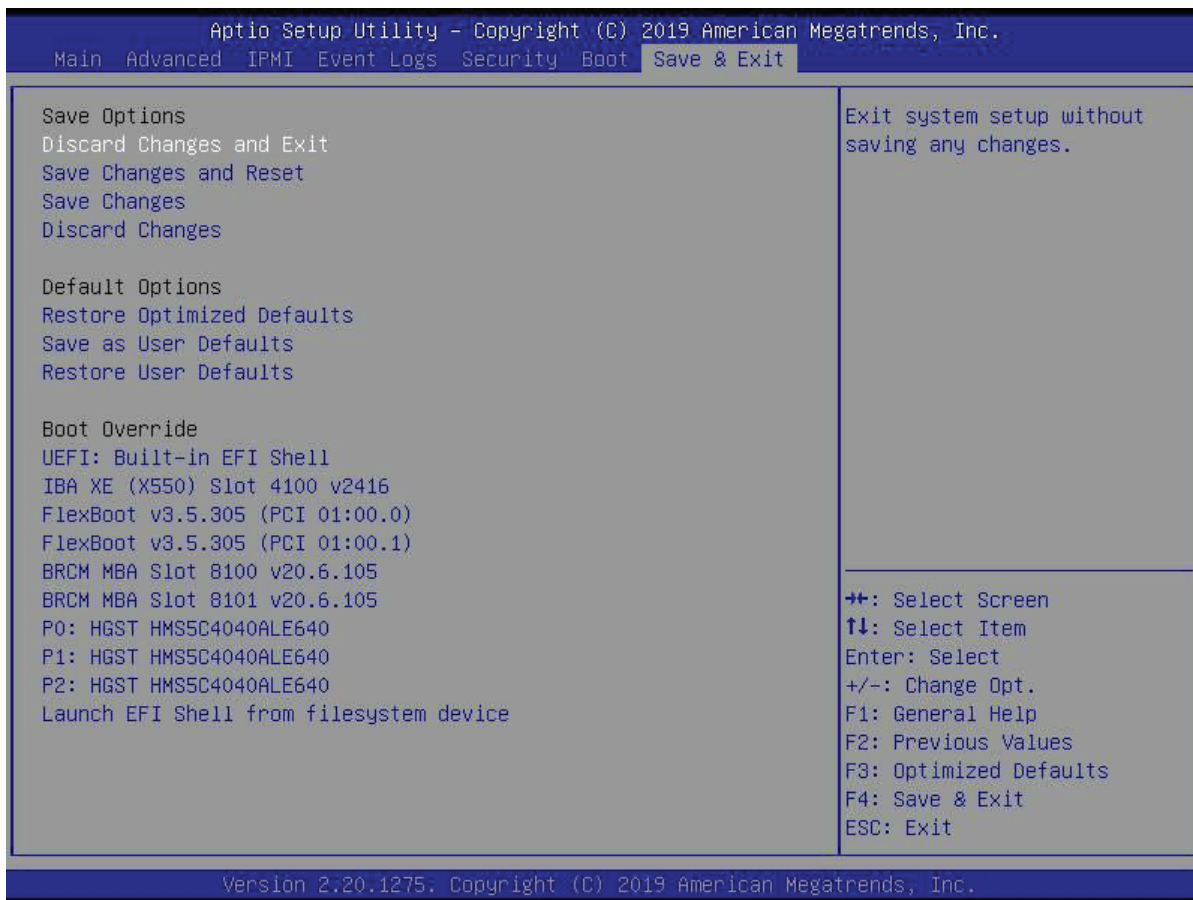

### Discard Changes and Exit

Select this option to quit the BIOS Setup without making any permanent changes to the system configuration, and reboot the computer. Select Discard Changes and Exit from the Exit menu and press <Enter>.

### Save Changes and Reset

Select this option to reset the system after saving the changes.

### Save Changes

After completing the system configuration changes, select this option to save the changes you have made. This will not reset (reboot) the system.

### Discard Changes

Select this option and press <Enter> to discard all the changes and return to the AMI BIOS utility Program.



## **Default Options**

### **Restore Optimized Defaults**

To set this feature, select Restore Defaults from the Save & Exit menu and press <Enter>. These are factory settings designed for maximum system stability, but not for maximum performance.

### **Save as User Defaults**

To set this feature, select Save as User Defaults from the Exit menu and press <Enter>. This enables the user to save any changes to the BIOS setup for future use.

### **Restore User Defaults**

To set this feature, select Restore User Defaults from the Exit menu and press <Enter>. Use this feature to retrieve user-defined settings that were saved previously.

### **Boot Override Section**

Listed on this section are other boot options for the system (i.e., Built-in EFI shell). Select an option and press <Enter>. Your system will boot to the selected boot option.

## Appendix A

### UEFI BIOS Recovery

**Warning:** Do not upgrade the BIOS unless your system has a BIOS-related issue. Flashing the wrong BIOS can cause irreparable damage to the system. In no event shall Supermicro be liable for direct, indirect, special, incidental, or consequential damages arising from a BIOS update. If you need to update the BIOS, do not shut down or reset the system while the BIOS is updating to avoid possible boot failure.

#### A.1 Overview

The Unified Extensible Firmware Interface (UEFI) provides a software-based interface between the operating system and the platform firmware in the pre-boot environment. The UEFI specification supports an architecture-independent mechanism that will allow the UEFI OS loader stored in an add-on card to boot the system. The UEFI offers clean, hands-off management to a computer during system boot.

#### A.2 Recovering the UEFI BIOS Image

A UEFI BIOS flash chip consists of a recovery BIOS block and a main BIOS block (a main BIOS image). The boot block contains critical BIOS codes, including memory detection and recovery codes for the user to flash a new BIOS image if the original main BIOS image is corrupted. When the system power is first turned on, the boot block codes execute first. Once this process is completed, the main BIOS code will continue with system initialization and the remaining POST (Power-On Self-Test) routines.

**Note 1:** Follow the BIOS recovery instructions below for BIOS recovery when the main BIOS boot crashes.

**Note 2:** When the BIOS boot block crashes, you will need to follow the procedures to make a Returned Merchandise Authorization (RMA) request. Also, you may use the Supermicro Update Manager (SUM) Out-of-Band (OOB) ([https://www.supermicro.com.tw/products/nfo/SMS\\_SUM.cfm](https://www.supermicro.com.tw/products/nfo/SMS_SUM.cfm)) to reflash the BIOS.

#### A.3 Recovering the BIOS Block with a USB Device

This feature allows the user to recover a BIOS image using a USB-attached device without additional utilities used. A USB flash device such as a USB Flash Drive, or a USB CD/DVD ROM/RW device can be used for this purpose. However, a USB Hard Disk drive cannot be used for BIOS recovery at this time.

The file system supported by UEFI is FAT (including FAT12, FAT16, and FAT32) which is installed on a bootable or non-bootable USB-attached device. However, the BIOS might need several minutes to locate the SUPER.ROM file if the media size becomes too large due to the huge volumes of folders and files stored in the device.

To perform UEFI BIOS recovery using a USB-attached device, follow the instructions below.

1. Using a different machine, copy the "Super.ROM" binary image file into the disc Root "\\" directory of a USB device or a writable CD/DVD.

**Note:** If you cannot locate the "Super.ROM" file in your driver disk, visit our website at [www.supermicro.com](http://www.supermicro.com) to download the BIOS image into a USB flash device and rename it "Super.ROM" for BIOS recovery use.

2. Insert the USB device that contains the new BIOS image ("Super.ROM") into your USB drive and power on the system
3. While powering on the system, please keep pressing <Ctrl> and <Home> simultaneously on your keyboard *until the following screen (or a screen similar to the one below) displays.*



**Note:** On the other hand, if the following screen displays, please load the "Super.ROM" file to the root folder and connect this folder to the system. (You can do so by inserting a USB device that contains the new "Super.ROM" image to your machine for BIOS recovery.)

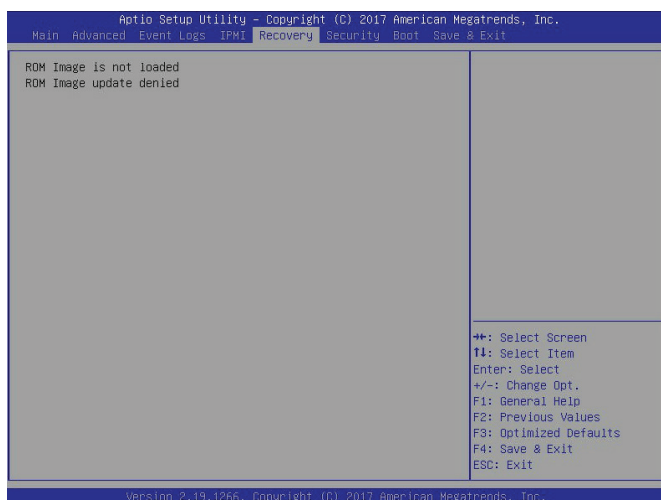

**Warning:** Please **stop** pressing the <Ctrl> and <Home> keys immediately when you see the

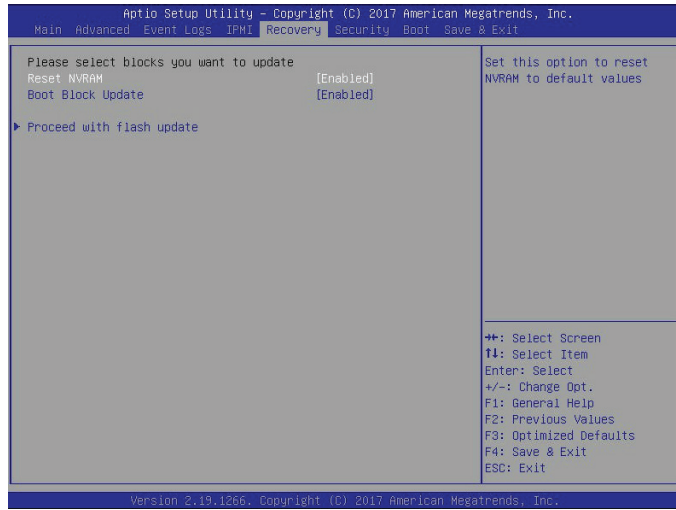

screen (or a similar screen) below; otherwise, it will trigger a system reboot.

4. After locating the new BIOS binary image, the system will enter the BIOS Recovery menu as shown below.

**Note:** At this point, you may decide if you want to start the BIOS recovery. If you decide to proceed with BIOS recovery, follow the procedures below.

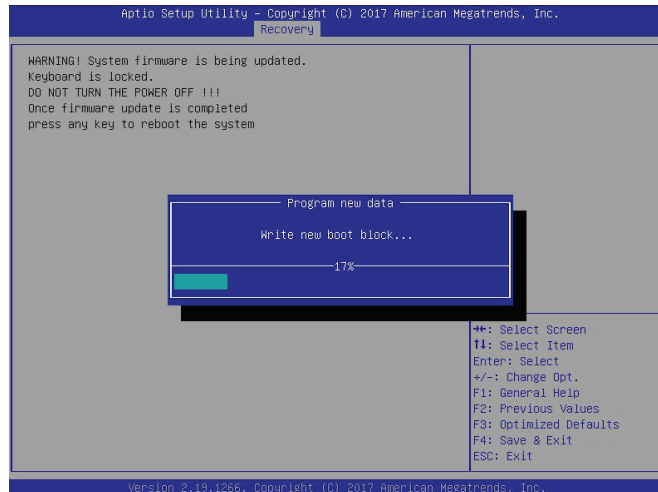

5. When the screen as shown above displays, use the arrow keys to select the item

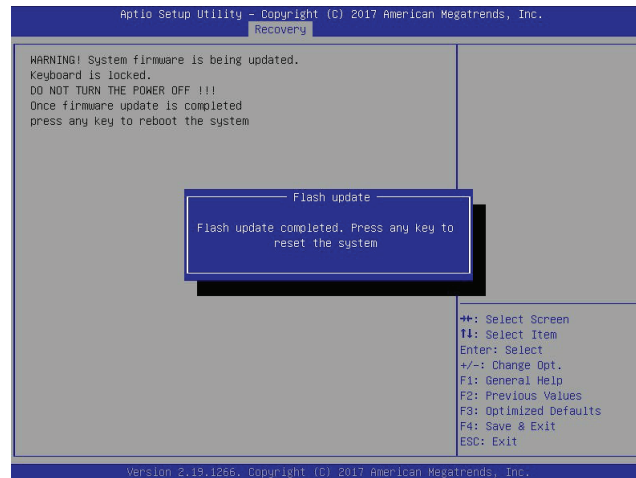

"Proceed with flash update" and press the <Enter> key. You will see the BIOS recovery progress as shown in the screen below.

**Note:** *Do not interrupt the BIOS flashing process until it has completed.*

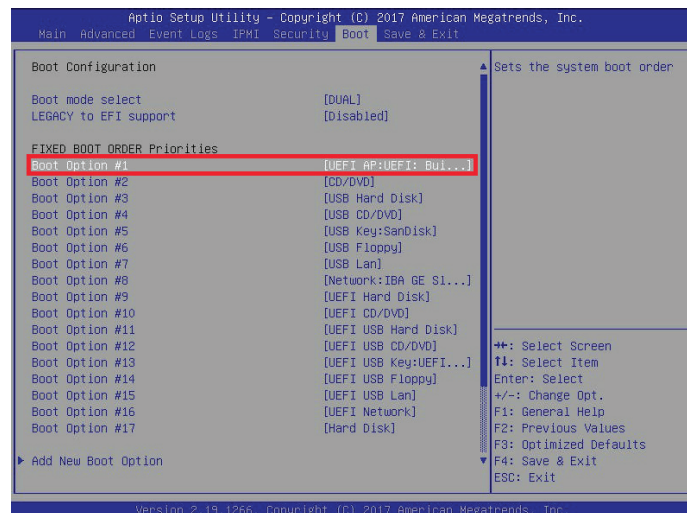

6. After the BIOS recovery process is completed, press any key to reboot the system.

7. Using a different system, extract the BIOS package into a USB flash drive.

```

UEFI Interactive Shell v2.1
EDK II
UEFI v2.50 (American Megatrends, 0x0005000C)
Mapping table
FS0: Alias(s):HD0r0b::BLK1:
Pc.Root(0x0)/Pci(0x14,0x0)/USB(0x11,0x0)/HD(1,MBR,0x37501D72,0x800,0x1
C89592)
BLK0: Alias(s):
Pc.Root(0x0)/Pci(0x14,0x0)/USB(0x11,0x0)
Press ESC in 1 seconds to skip startup.nsh or any other key to continue.
Shell: fs0:
FS0:\> cd #FUD0S
FS0:\#FUD0S\> cd SWJPWE2_09162017
FS0:\#FUD0S\SWJPWE2_09162017\> flash.nsh X11DPUT.314_

```

8. Press <Del> continuously during system boot to enter the BIOS setup utility. From the

```

Done.
[ Access Cmos Port Ex ]
<Read>
Index 0x51: 0x18
Done.
*****
* Program BIOS and ME (including FDT) regions...
*
*****
| AMI Firmware Update Utility v5.09.01.1317 |
| Copyright (C)2017 American Megatrends Inc. All Rights Reserved. |
*****
CPUID = 50652

Reading flash ..... done
- ME data size checking . ok
- FFS checksums ..... ok
- Check RomLayout ..... ok.
Erasing Boot Block ..... done
Updating Boot Block ..... done
Verifying Boot Block ..... done
Erasing Main Block ..... 0x00132000 (0%)

```

top of the tool bar, click on Boot and press <Enter> to enter the submenu. From the submenu list, select Boot Option #1 as shown below. Then, boot Option #1 to [UEFI

```

Verifying MCB Block ..... done
- Update success for FDR
- Update success for TE. -
- Successful Update Recovery Loader to OPRx!!
- Successful Update MFSB!!
- Successful Update FPR!!
- Successful Update MFS, IVB1 and IVB2!!
- Successful Update FLOG and UTK!!
- ME EntLine Image update success !!
WARNING : System must power-off to have the changes take effect!
Moving F80:\AFUDOS\SNJFME2_03162017\Fufef1k64.efi -> F80:\AFUDOS\SNJFME2_03162017\F
dt.smc
- [ok]
Moving F80:\AFUDOS\SNJFME2_03162017\Fufef1k64.efi -> F80:\AFUDOS\SNJFME2_0316201
7\Fufef1.smc
- [ok]
*****
* Please ignore this 'Shell: Cannot read from file - Device Error'
* warning message due to it does not impact flashing process.
*
*****
Deleting "F80:\AFUDOS\SNJFME2_03162017\Fufef1.smc"
Delete successful.
F80:\>

```

AP:UEFI: Built-in EFI Shell]. Press <F4> to save the settings and exit the BIOS setup utility.

9. When the UEFI Shell prompt appears, type fs# to change the device directory path. Go to the directory that contains the BIOS package you extracted earlier from Step 7. Enter flash.nsh BIOSname.### at the prompt to start the BIOS update process.

**Note:** *Do not interrupt this process* until the BIOS flashing is complete.

10. The screen above indicates that the BIOS update process is completed. When you see the screen above, unplug the AC power cable from the power supply, clear CMOS, and plug the AC power cable in the power supply again to power on the system.
11. Press <Del> continuously to enter the BIOS setup utility.
12. Press <F3> to load the default settings.
13. After loading the default settings, press <F4> to save the settings and exit the BIOS setup utility.

## Appendix B

# Standardized Warning Statements for AC Systems

## B.1 About Standardized Warning Statements

The following statements are industry standard warnings, provided to warn the user of situations which have the potential for bodily injury. Should you have questions or experience difficulty, contact Supermicro's Technical Support department for assistance. Only certified technicians should attempt to install or configure components.

Read this appendix in its entirety before installing or configuring components in the Supermicro chassis.

These warnings may also be found on our website at [http://www.supermicro.com/about/policies/safety\\_information.cfm](http://www.supermicro.com/about/policies/safety_information.cfm).

### Warning Definition



**Warning!** This warning symbol means danger. You are in a situation that could cause bodily injury. Before you work on any equipment, be aware of the hazards involved with electrical circuitry and be familiar with standard practices for preventing accidents.

#### 警告の定義

この警告サインは危険を意味します。

人身事故につながる可能性がありますので、いずれの機器でも動作させる前に、電気回路に含まれる危険性に注意して、標準的な事故防止策に精通して下さい。

此警告符号代表危險。

您正处于可能受到严重伤害的工作环境中。在您使用设备开始工作之前，必须充分意识到触电的危险，并熟练掌握防止事故发生的标准工作程序。请根据每项警告结尾的声明号码找到此设备的安全性警告说明的翻译文本。

此警告符號代表危險。

您正處於可能身體可能會受損傷的工作環境中。在您使用任何設備之前，請注意觸電的危險，並且要熟悉預防事故發生的標準工作程序。請依照每一注意事項後的號碼找到相關的翻譯說明內容。

## Warnung

### WICHTIGE SICHERHEITSHINWEISE

Dieses Warnsymbol bedeutet Gefahr. Sie befinden sich in einer Situation, die zu Verletzungen führen kann. Machen Sie sich vor der Arbeit mit Geräten mit den Gefahren elektrischer Schaltungen und den üblichen Verfahren zur Vorbeugung vor Unfällen vertraut. Suchen Sie mit der am Ende jeder Warnung angegebenen Anweisungsnummer nach der jeweiligen Übersetzung in den übersetzten Sicherheitshinweisen, die zusammen mit diesem Gerät ausgeliefert wurden.

BEWAHREN SIE DIESE HINWEISE GUT AUF.

### INSTRUCCIONES IMPORTANTES DE SEGURIDAD

Este símbolo de aviso indica peligro. Existe riesgo para su integridad física. Antes de manipular cualquier equipo, considere los riesgos de la corriente eléctrica y familiarícese con los procedimientos estándar de prevención de accidentes. Al final de cada advertencia encontrará el número que le ayudará a encontrar el texto traducido en el apartado de traducciones que acompaña a este dispositivo.

GUARDE ESTAS INSTRUCCIONES.

### IMPORTANTES INFORMATIONS DE SÉCURITÉ

Ce symbole d'avertissement indique un danger. Vous vous trouvez dans une situation pouvant entraîner des blessures ou des dommages corporels. Avant de travailler sur un équipement, soyez conscient des dangers liés aux circuits électriques et familiarisez-vous avec les procédures couramment utilisées pour éviter les accidents. Pour prendre connaissance des traductions des avertissements figurant dans les consignes de sécurité traduites qui accompagnent cet appareil, référez-vous au numéro de l'instruction situé à la fin de chaque avertissement.

CONSERVEZ CES INFORMATIONS.

## תקנון הזהרות אזהרה

הזהרות הבאות הן אזהרות על פי תקני התעשייה, על מנת להזהיר את המשתמש מפני חבלה פיזית אפשרית. במידה ויש שאלות או היתקלות בבעיה כלשהי, יש ליצור קשר עם מחלקת תמיכה טכנית של סופרמיקרו. טכנאים מוסמכים בלבד רשאים להתקין או להגדיר את הרכיבים. יש לקרוא את הנספח במלואו לפני התקנת או הגדרת הרכיבים במארזי סופרמיקרו.



اَكْ ف حالة وُكِي اَي تتسبب ف اصابة جسدهُ هذا الزهز عُ خطر! تحذُرُ .  
 قبل اَي تعول على اَي هعدات، كي على علن بالوخاطز ال اُجوة عي الذوائر  
 الكهزبائِة  
 وكي على دراةُ بالووارسات النقااِة لو عُ وقع اَي حادث  
 استخدم رقن الب اِى الو صُص ف هاةُ كل تحذُرُ للعشر تزجوتها

안전을 위한 주의사항

경고!

이 경고 기호는 위험이 있음을 알려 줍니다. 작업자의 신체에 부상을 야기 할 수 있는 상태에 있게 됩니다. 모든 장비에 대한 작업을 수행하기 전에 전기회로와 관련된 위험요소들을 확인하시고 사전에 사고를 방지할 수 있도록 표준 작업절차를 준수해 주시기 바랍니다.

해당 번역문을 찾기 위해 각 경고의 마지막 부분에 제공된 경고문 번호를 참조하십시오

#### BELANGRIJKE VEILIGHEIDSINSTRUCTIES

Dit waarschuwings symbool betekent gevaar. U verkeert in een situatie die lichamelijk letsel kan veroorzaken. Voordat u aan enige apparatuur gaat werken, dient u zich bewust te zijn van de bij een elektrische installatie betrokken risico's en dient u op de hoogte te zijn van de standaard procedures om ongelukken te voorkomen. Gebruik de nummers aan het eind van elke waarschuwing om deze te herleiden naar de desbetreffende locatie.

#### BEWAAR DEZE INSTRUCTIES

### Installation Instructions



**Warning!** Read the installation instructions before connecting the system to the power source.

#### 設置手順書

システムを電源に接続する前に、設置手順書をお読み下さい。

#### 警告

将此系统连接电源前,请先阅读安装说明。

#### 警告

將系統與電源連接前, 請先閱讀安裝說明。

### Warnung

Vor dem Anschließen des Systems an die Stromquelle die Installationsanweisungen lesen.

### ¡Advertencia!

Lea las instrucciones de instalación antes de conectar el sistema a la red de alimentación.

### Attention

Avant de brancher le système sur la source d'alimentation, consulter les directives d'installation.

יש לקרוא את הוראות התקנה לפני חיבור המערכת למקור מתח.

اقرأ إرشادات التركيب قبل توصيل النظام إلى مصدر للطاقة

시스템을 전원에 연결하기 전에 설치 안내를 읽어주십시오.

### Waarschuwing

Raadpleeg de installatie-instructies voordat u het systeem op de voedingsbron aansluit.

## Circuit Breaker



**Warning!** This product relies on the building's installation for short-circuit (overcurrent) protection. Ensure that the protective device is rated not greater than: 250 V, 20 A.

### サーキット・ブレーカー

この製品は、短絡(過電流)保護装置がある建物での設置を前提としています。

保護装置の定格が250 V、20 Aを超えないことを確認下さい。

### 警告

此产品的短路(过载电流)保护由建筑物的供电系统提供,确保短路保护设备的额定电流不大于250V,20A。

### 警告

此產品的短路(過載電流)保護由建築物的供電系統提供,確保短路保護設備的額定電流不大於250V,20A。

**Warnung**

Dieses Produkt ist darauf angewiesen, dass im Gebäude ein Kurzschluss- bzw. Überstromschutz installiert ist. Stellen Sie sicher, dass der Nennwert der Schutzvorrichtung nicht mehr als: 250 V, 20 A beträgt.

**¡Advertencia!**

Este equipo utiliza el sistema de protección contra cortocircuitos (o sobrecorrientes) del edificio. Asegúrese de que el dispositivo de protección no sea superior a: 250 V, 20 A.

**Attention**

Pour ce qui est de la protection contre les courts-circuits (surtension), ce produit dépend de l'installation électrique du local. Vérifiez que le courant nominal du dispositif de protection n'est pas supérieur à :250 V, 20 A.

מוצר זה מסתמך על הגנה המותקנת במבנים למניעת קצר חשמלי. יש לוודא כי המכשיר המגן מפני הקצר החשמלי הוא לא יותר מ-20A, 60VDC.

هذا المنتج يعتمد على معدات الحماية من الدوائر القصيرة التي تم تثبيتها في المبنى  
تأكد من أن تقييم الجهاز الوقائي ليس أكثر من : 20A, 250V

**경고!**

이 제품은 전원의 단락(과전류)방지에 대해서 전적으로 건물의 관련 설비에 의존합니다. 보호장치의 정격이 반드시 250V(볼트), 20A(암페어)를 초과하지 않도록 해야 합니다.

**Waarschuwing**

Dit product is afhankelijk van de kortsluitbeveiliging (overspanning) van uw elektrische installatie. Controleer of het beveiligde apparaat niet groter gedimensioneerd is dan 250V, 20A.

## Power Disconnection Warning



**Warning!** The system must be disconnected from all sources of power and the power cord removed from the power supply module(s) before accessing the chassis interior to install or remove system components.

### 電源切斷の警告

システムコンポーネントの取り付けまたは取り外しのために、シャーシ内部にアクセスするには、システムの電源はすべてのソースから切斷され、電源コードは電源モジュールから取り外す必要があります。

### 警告

在你打开机箱并安装或移除内部器件前,必须将系统完全断电,并移除电源线。

### 警告

在您打開機殼安裝或移除內部元件前, 必須將系統完全斷電, 並移除電源線。

### Warnung

Das System muss von allen Quellen der Energie und vom Netzanschlusskabel getrennt sein, das von den Spg.Versorgungsteilmodulen entfernt wird, bevor es auf den Chassisinnenraum zurückgreift, um Systemsbestandteile anzubringen oder zu entfernen.

### ¡Advertencia!

El sistema debe ser disconnected de todas las fuentes de energía y del cable eléctrico quitado de los módulos de fuente de alimentación antes de tener acceso el interior del chasis para instalar o para quitar componentes de sistema.

### Attention

Le système doit être débranché de toutes les sources de puissance ainsi que de son cordon d'alimentation secteur avant d'accéder à l'intérieur du chassis pour installer ou enlever des composants de système.

אזהרה מפני ניתוק חשמלי

אזהרה!

יש לנתק את המערכת מכל מקורות החשמל ויש להסיר את כבל החשמלי מהספק לפני גישה לחלק הפנימי של המארז לצורך התקנת או הסרת רכיבים.

يجب فصل انظاؤ من جميع مصادر انطاقت وإزانت سهك انكهرباء من وحدة امداد  
انطاقت قيم  
انصل إلى امناطق انداخهيت نههيكم نتشيج أو إزانت مكناث الجهاز

경고!

시스템에 부품들을 장착하거나 제거하기 위해서는 새시 내부에 접근하기 전에 반드시 전원 공급장치로부터 연결되어있는 모든 전원과 전기코드를 분리해주어야 합니다.

Waarschuwing

Voordat u toegang neemt tot het binnenwerk van de behuizing voor het installeren of verwijderen van systeem onderdelen, dient u alle spanningsbronnen en alle stroomkabels aangesloten op de voeding(en) van de behuizing te verwijderen

## Equipment Installation



**Warning!** Only trained and qualified personnel should be allowed to install, replace, or service this equipment.

機器の設置

トレーニングを受け認定された人だけがこの装置の設置、交換、またはサービスを許可されていません。

警告

只有经过培训且具有资格的人员才能进行此设备的安装、更换和维修。

警告

只有經過受訓且具資格人員才可安裝、更換與維修此設備。

Warnung

Das Installieren, Ersetzen oder Bedienen dieser Ausrüstung sollte nur geschultem, qualifiziertem Personal gestattet werden.

¡Advertencia!

Solamente el personal calificado debe instalar, reemplazar o utilizar este equipo.

#### Attention

Il est vivement recommandé de confier l'installation, le remplacement et la maintenance de ces équipements à des personnels qualifiés et expérimentés.

אזהרה!

צוות מוסמך בלבד רשאי להתקין, להחליף את הציוד או לתת שירות עבור הציוד.

والمدربيه لتزكيب واستبدال أو خدمة هذا الجهاز يجب أن يسمح فقط للمظفيه المؤهليه

경고!

훈련을 받고 공인된 기술자만이 이 장비의 설치, 교체 또는 서비스를 수행할 수 있습니다.

#### Waarschuwing

Deze apparatuur mag alleen worden geïnstalleerd, vervangen of hersteld door geschoold en gekwalificeerd personeel.

### Restricted Area



**Warning!** This unit is intended for installation in restricted access areas. A restricted access area can be accessed only through the use of a special tool, lock and key, or other means of security. (This warning does not apply to workstations).

#### アクセス制限区域

このユニットは、アクセス制限区域に設置されることを想定しています。

アクセス制限区域は、特別なツール、鍵と錠前、その他のセキュリティの手段を用いてのみ出入りが可能です。

#### 警告

此部件应安装在限制进出的场所，限制进出的场所指只能通过使用特殊工具、锁和钥匙或其它安全手段进出的场所。

#### 警告

此裝置僅限安裝於進出管制區域，進出管制區域係指僅能以特殊工具、鎖頭及鑰匙或其他安全方式才能進入的區域。

**Warnung**

Diese Einheit ist zur Installation in Bereichen mit beschränktem Zutritt vorgesehen. Der Zutritt zu derartigen Bereichen ist nur mit einem Spezialwerkzeug, Schloss und Schlüssel oder einer sonstigen Sicherheitsvorkehrung möglich.

**¡Advertencia!**

Esta unidad ha sido diseñada para instalación en áreas de acceso restringido. Sólo puede obtenerse acceso a una de estas áreas mediante la utilización de una herramienta especial, cerradura con llave u otro medio de seguridad.

**Attention**

Cet appareil doit être installé dans des zones d'accès réservés. L'accès à une zone d'accès réservé n'est possible qu'en utilisant un outil spécial, un mécanisme de verrouillage et une clé, ou tout autre moyen de sécurité.

אזור עם גישה מוגבלת

אזהרה!

יש להתקין את היחידה באזורים שיש בהם הגבלת גישה. הגישה ניתנת בעזרת 'כלי אבטחה בלבד' (מפתח, מנעול וכד.).

تخصيص هذه انحدة نترك بها ف مناطق محظورة تم .  
ممكن انصلل إن منطقت محظورة فقط من خلال استخذاو أداة خاصت  
أو أ وس هُت أخري نلالأمما ققم ومفتاح

**경고!**

이 장치는 접근이 제한된 구역에 설치하도록 되어있습니다. 특수도구, 잠금 장치 및 키, 또는 기타 보안 수단을 통해서만 접근 제한 구역에 들어갈 수 있습니다.

**Waarschuwing**

Dit apparaat is bedoeld voor installatie in gebieden met een beperkte toegang. Toegang tot dergelijke gebieden kunnen alleen verkregen worden door gebruik te maken van speciaal gereedschap, slot en sleutel of andere veiligheidsmaatregelen.

## Battery Handling



**Warning!** There is the danger of explosion if the battery is replaced incorrectly. Replace the battery only with the same or equivalent type recommended by the manufacturer. Dispose of used batteries according to the manufacturer's instructions

### 電池の取り扱い

電池交換が正しく行われなかった場合、破裂の危険性があります。交換する電池はメーカーが推奨する型、または同等のものを使用下さい。使用済電池は製造元の指示に従って処分して下さい。

### 警告

電池更換不當會有爆炸危險。請只使用同類電池或制造商推薦的功能相當的電池更換原有電池。請按製造商的說明處理廢舊電池。

### 警告

電池更換不當會有爆炸危險。請使用製造商建議之相同或功能相當的電池更換原有電池。請按照製造商的說明指示處理廢棄舊電池。

### Warnung

Bei Einsetzen einer falschen Batterie besteht Explosionsgefahr. Ersetzen Sie die Batterie nur durch den gleichen oder vom Hersteller empfohlenen Batterietyp. Entsorgen Sie die benutzten Batterien nach den Anweisungen des Herstellers.

### Attention

Danger d'explosion si la pile n'est pas remplacée correctement. Ne la remplacer que par une pile de type semblable ou équivalent, recommandée par le fabricant. Jeter les piles usagées conformément aux instructions du fabricant.

### ¡Advertencia!

Existe peligro de explosión si la batería se reemplaza de manera incorrecta. Reemplazar la batería exclusivamente con el mismo tipo o el equivalente recomendado por el fabricante. Desechar las baterías gastadas según las instrucciones del fabricante.

אזהרה!

קיימת סכנת פיצוץ של הסוללה במידה והוחלפה בדרך לא תקינה. יש להחליף את הסוללה בסוג התואם מחברת יצרן מומלצת. סילוק הסוללות המשומשות יש לבצע לפי הוראות היצרן.



هناك خطر من انفجار في حالة اسبدال البطارية بطريقة غير صحيحة فعلى  
اسبدال البطارية  
فقط بنفس النوع أو ما يعادلها مما أوصت به الشركة المصنعة  
جخلص من البطاريات المسحومة وفقا لعمليات الشركة الصانعة

경고!

배터리가 올바르게 교체되지 않으면 폭발의 위험이 있습니다. 기존 배터리와 동일하거나 제조사에서 권장하는 동등한 종류의 배터리로만 교체해야 합니다. 제조사의 안내에 따라 사용된 배터리를 처리하여 주십시오.

Waarschuwing

Er is ontplofingsgevaar indien de batterij verkeerd vervangen wordt. Vervang de batterij slechts met hetzelfde of een equivalent type die door de fabrikant aanbevolen wordt. Gebruikte batterijen dienen overeenkomstig fabrieksvoorschriften afgevoerd te worden.

## Redundant Power Supplies



**Warning!** This unit might have more than one power supply connection. All connections must be removed to de-energize the unit.

冗長電源装置

このユニットは複数の電源装置が接続されている場合があります。

ユニットの電源を切るためには、すべての接続を取り外さなければなりません。

警告

此部件连接的电源可能不止一个，必须将所有电源断开才能停止给该部件供电。

警告

此装置连接的电源可能不只一个，必须切断所有电源才能停止对该装置的供电。

Warnung

Dieses Gerät kann mehr als eine Stromzufuhr haben. Um sicherzustellen, dass der Einheit kein Strom zugeführt wird, müssen alle Verbindungen entfernt werden.

¡Advertencia!

Puede que esta unidad tenga más de una conexión para fuentes de alimentación. Para cortar por completo el suministro de energía, deben desconectarse todas las conexiones.

Attention

Cette unité peut avoir plus d'une connexion d'alimentation. Pour supprimer toute tension et tout courant électrique de l'unité, toutes les connexions d'alimentation doivent être débranchées.

אם קיים יותר מספק אחד

אזהרה!

ליחידה יש יותר מחיבור אחד של ספק. יש להסיר את כל החיבורים על מנת לרוקן את היחידה.

قد يكون لهذا الجهاز عدة اتصالات بوحدات امداد الطاقة .  
يجب إزالة كافة الاتصالات لعسل الوحدة عن الكهرباء

경고!

이 장치에는 한 개 이상의 전원 공급 단자가 연결되어 있을 수 있습니다. 이 장치에 전원을 차단하기 위해서는 모든 연결 단자를 제거해야만 합니다.

Waarschuwing

Deze eenheid kan meer dan één stroomtoevoeraansluiting bevatten. Alle aansluitingen dienen verwijderd te worden om het apparaat stroomloos te maken.

## Backplane Voltage



**Warning!** Hazardous voltage or energy is present on the backplane when the system is operating. Use caution when servicing.

バックプレーンの電圧

システムの稼働中は危険な電圧または電力が、バックプレーン上にかかっています。

修理する際には注意ください。

警告

当系统正在进行时，背板上有很危险的电压或能量，进行维修时务必小心。

警告

當系統正在進行時，背板上危險的電壓或能量，進行維修時務必小心。

Warnung

Wenn das System in Betrieb ist, treten auf der Rückwandplatine gefährliche Spannungen oder Energien auf. Vorsicht bei der Wartung.

¡Advertencia!

Cuando el sistema está en funcionamiento, el voltaje del plano trasero es peligroso. Tenga cuidado cuando lo revise.

Attention

Lorsque le système est en fonctionnement, des tensions électriques circulent sur le fond de panier. Prendre des précautions lors de la maintenance.

מתח בפנל האחורי

אזהרה!

קיימת סכנת מתח בפנל האחורי בזמן תפעול המערכת. יש להיזהר במהלך העבודה.

هناك خطر من التيار الكهربائي أو الطاقة المتجددة على اللوحة  
عندما يكون النظام يعمل كه حذرا عند خدمة هذا الجهاز

경고!

시스템이 동작 중일 때 후면판 (Backplane)에는 위험한 전압이나 에너지가 발생 합니다.  
서비스 작업 시 주의하십시오.

Waarschuwing

Een gevaarlijke spanning of energie is aanwezig op de backplane wanneer het systeem in gebruik is. Voorzichtigheid is geboden tijdens het onderhoud.

## Comply with Local and National Electrical Codes



**Warning!** Installation of the equipment must comply with local and national electrical codes.

地方および国の電気規格に準拠

機器の取り付けはその地方および国の電気規格に準拠する必要があります。

警告

设备安装必须符合本地与本国电气法规。

警告

設備安裝必須符合本地與本國電氣法規。

Warnung

Die Installation der Geräte muss den Sicherheitsstandards entsprechen.

¡Advertencia!

La instalación del equipo debe cumplir con las normas de electricidad locales y nacionales.

Attention

L'équipement doit être installé conformément aux normes électriques nationales et locales.

תיאום חוקי החשמל הארצי

אזהרה!

התקנת הציוד חייבת להיות תואמת לחוקי החשמל המקומיים והארציים.

تركيب المعدات الكهربائية يجب أن يمتثل للقوايه المحلية والبطية المتعلقة  
بالكهرباء

경고!

현 지역 및 국가의 전기 규정에 따라 장비를 설치해야 합니다.

Waarschuwing

Bij installatie van de apparatuur moet worden voldaan aan de lokale en nationale elektriciteitsvoorschriften.

## Product Disposal



**Warning!** Ultimate disposal of this product should be handled according to all national laws and regulations.

製品の廃棄

この製品を廃棄処分する場合、国の関係する全ての法律・条例に従い処理する必要があります。

警告

本产品的废弃处理应根据所有国家的法律和规章进行。

警告

本產品的廢棄處理應根據所有國家的法律和規章進行。

Warnung

Die Entsorgung dieses Produkts sollte gemäß allen Bestimmungen und Gesetzen des Landes erfolgen.

¡Advertencia!

Al deshacerse por completo de este producto debe seguir todas las leyes y reglamentos nacionales.

### Attention

La mise au rebut ou le recyclage de ce produit sont généralement soumis à des lois et/ou directives de respect de l'environnement. Renseignez-vous auprès de l'organisme compétent.

סילוק המוצר

אזהרה!

סילוק סופי של מוצר זה חייב להיות בהתאם להנחיות וחוקי המדינה.

التخلص النهائي من هذا المنتج ينبغي التعامل معه وفقا لجميع القوانين واللوائح الوطنية عند

### 경고!

이 제품은 해당 국가의 관련 법규 및 규정에 따라 폐기되어야 합니다.

### Waarschuwing

De uiteindelijke verwijdering van dit product dient te geschieden in overeenstemming met alle nationale wetten en reglementen.

## Hot Swap Fan Warning



**Warning!** Hazardous moving parts. Keep away from moving fan blades. The fans might still be turning when you remove the fan assembly from the chassis. Keep fingers, screwdrivers, and other objects away from the openings in the fan assembly's housing.

### ファン・ホットスワップの警告

警告!回転部品に注意。運転中は回転部(羽根)に触れないでください。シャーシから冷却ファン装置を取り外した際、ファンがまだ回転している可能性があります。ファンの開口部に、指、ドライバー、およびその他のものを近づけないで下さい。

### 警告!

警告! 危險的可移動性零件。請務必與轉動的风扇叶片保持距離。當您從機架移除風扇裝置，風扇可能仍在轉動。小心不要將手指、螺絲起子和其他物品太靠近風扇

### 警告

危險的可移動性零件。請務必與轉動的风扇叶片保持距離。當您從機架移除風扇裝置，風扇可能仍在轉動。小心不要將手指、螺絲起子和其他物品太靠近風扇。

**Warnung**

Gefährlich Bewegende Teile. Von den bewegenden Lüfterblätter fern halten. Die Lüfter drehen sich u. U. noch, wenn die Lüfterbaugruppe aus dem Chassis genommen wird. Halten Sie Finger, Schraubendreher und andere Gegenstände von den Öffnungen des Lüftergehäuses entfernt.

**¡Advertencia!**

Riesgo de piezas móviles. Mantener alejado de las aspas del ventilador. Los ventiladores podran dar vuelta cuando usted quite el montaje del ventilador del chasis. Mantenga los dedos, los destornilladores y todos los objetos lejos de las aberturas del ventilador

**Attention**

Pieces mobiles dangereuses. Se tenir a l'écart des lames du ventilateur Il est possible que les ventilateurs soient toujours en rotation lorsque vous retirerez le bloc ventilateur du châssis. Prenez garde à ce que doigts, tournevis et autres objets soient éloignés du logement du bloc ventilateur.

**אזהרה!**

חלקים נעים מסוכנים. התרחק מלהבי המאוורר בפעולה כאשר מסירים את חלקי המאוורר מהמארז, יתכן והמאווררים עדיין עובדים. יש להרחיק למרחק בטוח את האצבעות וכלי עבודה שונים מהפתחים בתוך המאוורר

تحذير! أجزاء متحركة خطيرة. ابتعد عن شفرات المروحة المتحركة. من الممكن أن المراوح لا تزال تدور عند إزالة كتلة المروحة من الهيكل يجب إبقاء الأصابع ومفكات البراغي وغيرها من الأشياء بعيدا عن الفتحات في كتلة المروحة

**경고!**

움직이는 위험한 부품. 회전하는 송풍 날개에 접근하지 마세요. 새시로부터 팬 조립품을 제거할 때 팬은 여전히 회전하고 있을 수 있습니다. 팬 조립품 외관의 열려있는 부분들로부터 손가락 및 스크류드라이버, 다른 물체들이 가까이 하지 않도록 배치해 주십시오.

**Waarschuwing**

Gevaarlijk bewegende onderdelen. Houd voldoende afstand tot de bewegende ventilatorbladen. Het is mogelijk dat de ventilator nog draait tijdens het verwijderen van het ventilatorsamenstel uit het chassis. Houd uw vingers, schroevendraaiers en eventuele andere voorwerpen uit de buurt van de openingen in de ventilatorbehuizing.

## Power Cable and AC Adapter



**Warning!** When installing the product, use the provided or designated connection cables, power cables and AC adaptors. Using any other cables and adaptors could cause a malfunction or a fire. Electrical Appliance and Material Safety Law prohibits the use of UL or CSA -certified cables (that have UL/CSA shown on the code) for any other electrical devices than products designated by Supermicro only.

### 電源コードとACアダプター

製品を設置する場合、提供または指定および購入された接続ケーブル、電源コードとACアダプターを該当する地域の条例や安全基準に適合するコードサイズやプラグと共に使用下さい。他のケーブルやアダプタを使用すると故障や火災の原因になることがあります。

電気用品安全法は、ULまたはCSA認定のケーブル(UL/CSEマークがコードに表記)を Supermicro が指定する製品以外に使用することを禁止しています。

### 警告

安装此产品时,请使用本身提供的或指定的或采购的连接线,电源线和电源适配器, 包含遵照当地法规和安全要求的合规的电源线尺寸和插头.使用其它线材或适配器可能会引起故障或火灾。除了Supermicro所指定的产品,电气用品和材料安全法律规定禁止使用未经UL或CSA认证的线材。(线材上会显示UL/CSA符号)。

### 警告

安裝此產品時,請使用本身提供的或指定的或採購的連接線,電源線和電源適配器, 包含遵照當地法規和安全要求的合規的電源線尺寸和插頭.使用其它線材或適配器可能會引起故障或火災。除了Supermicro所指定的產品,電氣用品和材料安全法律規定禁止使用未經UL或CSA認證的線材。(線材上會顯示UL/CSA符號)。

### Warnung

Nutzen Sie beim Installieren des Produkts ausschließlich die von uns zur Verfügung gestellten Verbindungskabeln, Stromkabeln und/oder Adapter, die Ihre örtlichen Sicherheitsstandards einhalten. Der Gebrauch von anderen Kabeln und Adapter können Fehlfunktionen oder Feuer verursachen. Die Richtlinien untersagen das Nutzen von UL oder CAS zertifizierten Kabeln (mit UL/CSA gekennzeichnet), an Geräten oder Produkten die nicht mit Supermicro gekennzeichnet sind.



## ¡Advertencia!

Cuando instale el producto, utilice la conexión provista o designada o procure cables, Cables de alimentación y adaptadores de CA que cumplan con los códigos locales y los requisitos de seguridad, incluyendo el tamaño adecuado del cable y el enchufe. El uso de otros cables y adaptadores podría causar un mal funcionamiento o un incendio. La Ley de Seguridad de Aparatos Eléctricos y de Materiales prohíbe El uso de cables certificados por UL o CSA (que tienen el certificado UL / CSA en el código) para cualquier otros dispositivos eléctricos que los productos designados únicamente por Supermicro.

## Attention

Lors de l'installation du produit, utilisez les cables de connection fournis ou désigné ou achetez des cables, cables de puissance et adaptateurs respectant les normes locales et les conditions de securite y compris les tailles de cables et les prises electriques appropries. L'utilisation d'autres cables et adaptateurs peut provoquer un dysfonctionnement ou un incendie. Appareils électroménagers et la Loi sur la Sécurité Matériel interdit l'utilisation de câbles certifiés- UL ou CSA (qui ont UL ou CSA indiqué sur le code) pour tous les autres appareils électriques sauf les produits désignés par Supermicro seulement.

AC כבלים חשמליים ומתאמי

!אזהרה

אשר נרכשו או הותאמו לצורך ההתקנה, ואשר הותאמו לדרישות AC כאשר מתקינים את המוצר, יש להשתמש בכבלים, ספקים ומתאמים הבטיחות המקומיות, כולל מידה נכונה של הכבל והתקע. שימוש בכל כבל או מתאם מסוג אחר, עלול לגרום לתקלה או קצר חשמלי. בהתאם כאשר מופיע עליהם קוד) UL-CSA או ב UL - לחוקי השימוש במכשירי החשמל וחוקי הבטיחות, קיים איסור להשתמש בכבלים המוסמכים ב Supermicro עבור כל מוצר חשמלי אחר, אלא רק במוצר אשר הותאם ע"י UL/CSA של

עند تركيب المنتج، قم باستخدام التوصيلات المتوفرة أو المحددة أو قم بشراء الكابلات الكهربائية ومحوّلات التيار المتردد مع الالتزام بقوانين ومتطلبات السلامة المحلية بما في ذلك حجم الموصل والقابس السليم. استخدام أي كابلات ومحوّلات أخرى قد يتسبب في عطل أو حريق. يحظر قانون السلامة للأجهزة الكهربائية والمعدات استخدام الكابلات المعتمدة Supermicro مع أي معدات أخرى غير المنتجات المعينة والمحددة من قبل (UL/CSA) والتي تحمل علامة CSA أو UL من قبل

### 전원 케이블 및 AC 어댑터

경고! 제품을 설치할 때 현지 코드 및 적절한 굵기의 코드와 플러그를 포함한 안전 요구 사항을 준수하여 제공되거나 지정된 연결 혹은 구매 케이블, 전원 케이블 및 AC 어댑터를 사용하십시오.

다른 케이블이나 어댑터를 사용하면 오작동이나 화재가 발생할 수 있습니다. 전기 용품 안전법은 UL 또는 CSA 인증 케이블 (코드에 UL / CSA가 표시된 케이블)을 Supermicro 가 지정한 제품 이외의 전기 장치에 사용하는 것을 금지합니다.

### Stroomkabel en AC-Adapter

Waarschuwing! Bij het aansluiten van het Product uitsluitend gebruik maken van de geleverde Kabels of een andere geschikte aan te schaffen Aansluitmethode, deze moet altijd voldoen aan de lokale voorschriften en veiligheidsnormen, inclusief de juiste kabeldikte en stekker. Het gebruik van niet geschikte Kabels en/of Adapters kan een storing of brand veroorzaken. Wetgeving voor Elektrische apparatuur en Materiaalveiligheid verbied het gebruik van UL of CSA -gecertificeerde Kabels (met UL/CSA in de code) voor elke andere toepassing dan de door Supermicro hiervoor beoogde Producten.

# Appendix C

## System Specifications

### Processor

Single AMD EPYC® 7002 Series System on Chip processor with up to 240W TDP per node

### BIOS

256Mb SPI AMI BIOS®

ACPI 6.2, SMBIOS 3.1.1, Plug-and-Play (PnP), RTC (Real Time Clock) wake up, Riser Card Auto-Detection Support

### Memory (per node)

Supports up to 2TB of ECC DDR4 RDIMM/LRDIMM/3DS/NVDIMM with speeds of up to 3200MHz in eight memory slots

### Storage (per node)

Four hybrid M.2 slots in the 2280 and 22110 form factors

Three hot-swap 3.5" SATA drive bays

### Expansion Slots (per node)

Two PCI-E 4.0 x16 low profile (6.6" long) slots

### Networking (per node)

One PCI-E 4.0 x16 + x1 S1OM networking slot

### Motherboard

One H12SST-PS per node; proprietary form factor: 18.86" (L) x 6.8" (W) (479.04 mm x 172.72 mm)

### Chassis

SC827HQ+-R2K04BP2 (2U rackmount)

Dimensions: (WxHxD) 17.25 x 3.47 x 28.5 in. (438 x 88 x 724 mm)

### System Cooling

Four heavy duty mid-chassis fans with optimal fan speed control

### Power Supply

Model: PWS-2K04A-1R

AC Input Voltages: 100-240 VAC

Rated Input Current: 14-11A (110-140V), 12.5-9.5A (180-240V)

Rated Input Frequency: 50-60Hz

Rated Output Power: 2000 Watts

Rated Output Voltages: +12V (167A), +5Vsb (1A)

### Operating Environment

Operating Temperature: 0° to 35° C (32° to 95° F)

Non-operating Temperature: -40° to 70° C (-40° to 158° F)

Operating Relative Humidity: 20% to 95% (non-condensing)

Non-operating Relative Humidity: 5 to 95% (non-condensing)

### **Regulatory Compliance**

Electromagnetic Emissions: FCC Class A, EN 55032 Class A, EN 61000-3-2/3-3, CISPR 32 Class A

Electromagnetic Immunity: EN 55024/CISPR 24, (EN 61000-4-2, EN 61000-4-3, EN 61000-4-4, EN 61000-4-5, EN 61000-4-6, EN 61000-4-8, EN 61000-4-11), CNS14336-1, CNS13438, GB4943.1-2011, GB9254-2008(Class A) and GB17625.1-2012

Safety: CSA/EN/IEC/UL 60950-1 Compliant, UL or CSA Listed (USA and Canada), CE Marking (Europe)

Other: VCCI-CISPR 32 and AS/NZS CISPR 32

Environmental: Directive 2011/65/EU, Delegated Directive (EU) 2015/863 and Directive 2012/19/EU

### **Perchlorate Warning**

California Best Management Practices Regulations for Perchlorate Materials: This Perchlorate warning applies only to products containing CR (Manganese Dioxide) Lithium coin cells. "Perchlorate Material-special handling may apply. See [www.dtsc.ca.gov/hazardouswaste/perchlorate](http://www.dtsc.ca.gov/hazardouswaste/perchlorate)"