

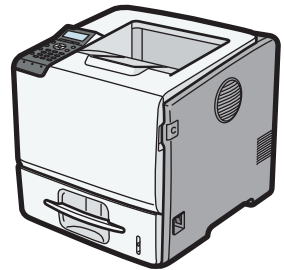

Operating Instructions Hardware Guide



-
- 1** Guide to the Printer
 - 2** Setting Up the Printer
 - 3** Installing Options
 - 4** Connecting the Printer
 - 5** Configuration
 - 6** Loading Paper
 - 7** Maintaining the Printer
 - 8** Adjusting the Printer
 - 9** Troubleshooting
 - 10** Removing Misfed Paper
 - 11** Appendix

Introduction

This manual contains detailed instructions and notes on the operation and use of this machine. For your safety and benefit, read this manual carefully before using the machine. Keep this manual in a handy place for quick reference.

Do not copy or print any item for which reproduction is prohibited by law.

Copying or printing the following items is generally prohibited by local law:

bank notes, revenue stamps, bonds, stock certificates, bank drafts, checks, passports, driver's licenses.

The preceding list is meant as a guide only and is not inclusive. We assume no responsibility for its completeness or accuracy. If you have any questions concerning the legality of copying or printing certain items, consult with your legal advisor.

Important

Contents of this manual are subject to change without prior notice.

In no event will the company be liable for direct, indirect, special, incidental, or consequential damages as a result of handling or operating the machine.

For good print quality, the manufacturer recommends that you use genuine toner from the manufacturer.

The manufacturer shall not be responsible for any damage or expense that might result from the use of parts other than genuine parts from the manufacturer with your office products.

Some illustrations in this manual might be slightly different from the machine.

Certain options might not be available in some countries. For details, please contact your local dealer.

TABLE OF CONTENTS

| | |
|--|----|
| How to Read This Manual..... | 6 |
| Symbols..... | 6 |
| Model-Specific Information..... | 7 |
| Machine Types..... | 7 |
| Positions of WARNING and CAUTION Labels..... | 9 |
| Power Switch Symbols..... | 10 |
| Manuals for This Printer..... | 11 |
| List of Options..... | 13 |
| Operating Instructions..... | 14 |
| Reading the HTML Manuals on the CD-ROMs..... | 14 |
| Reading the HTML Manuals That You Install on the Computer..... | 14 |

1. Guide to the Printer

| | |
|------------------------------|----|
| Exterior: Front View..... | 17 |
| Exterior: Rear View..... | 19 |
| Interior..... | 21 |
| Control Panel..... | 23 |
| Display Panel..... | 25 |
| Entering Characters..... | 26 |
| How to Enter Characters..... | 27 |

2. Setting Up the Printer

| | |
|---|----|
| Printer Setup Procedure..... | 31 |
| Place to Install..... | 32 |
| Unpacking..... | 36 |
| Turning the Printer's Power On and Off..... | 39 |
| Turning on the Power..... | 39 |
| Turning off the Power..... | 41 |
| Selecting the Display Language..... | 43 |
| Test Printing..... | 44 |

3. Installing Options

| | |
|--|----|
| Available Options..... | 45 |
| Order of Option Installation..... | 45 |
| Where to Install Options..... | 45 |
| Caution When Re-installing the Controller Board..... | 47 |

| | |
|--|----|
| Attaching the Paper Feed Unit..... | 48 |
| Installing the Memory Expansion Units..... | 52 |
| Installing the Hard Disk..... | 52 |
| Installing the SDRAM Module..... | 55 |
| Installing the Interface Units..... | 59 |
| Installing the Gigabit Ethernet Board..... | 59 |
| Installing the Wireless LAN Interface Board..... | 61 |
| Installing the IEEE 1284 Interface Board..... | 63 |
| Installing the SD Memory Card Options..... | 66 |

4. Connecting the Printer

| | |
|--------------------------------|----|
| Ethernet Cable Connection..... | 69 |
| Reading the LED Lamps..... | 71 |
| USB Cable Connection..... | 72 |
| Parallel Cable Connection..... | 74 |

5. Configuration

| | |
|--|----|
| Ethernet Configuration..... | 75 |
| Specifying an IP Address (No DHCP)..... | 76 |
| Receiving an IP Address Automatically (DHCP)..... | 78 |
| Configuring Network Settings When Using NetWare..... | 80 |
| Setting the Ethernet Speed..... | 81 |
| Wireless LAN Configuration..... | 84 |
| Setting the SSID..... | 86 |
| Confirming Wireless Network Connectivity..... | 87 |
| Cautions When Using a Wireless LAN..... | 87 |
| Setting Security Method of Wireless LAN..... | 89 |
| Setting a WEP Key..... | 89 |
| Setting WPA..... | 90 |
| Configuring IEEE 802.1X..... | 94 |
| Installing a Site Certificate..... | 94 |
| Installing Device Certificate..... | 94 |
| Setting Items of IEEE 802.1X for Ethernet..... | 95 |
| Setting Items of IEEE 802.1X for Wireless LAN..... | 97 |

6. Loading Paper

| | |
|--|-----|
| Supported Paper for Each Tray..... | 101 |
| Symbols..... | 101 |
| Standard Paper Feed Tray..... | 101 |
| Optional Paper Feed Tray..... | 102 |
| Bypass Tray..... | 104 |
| Supported Paper Types..... | 105 |
| Plain Paper..... | 105 |
| Middle Thick..... | 106 |
| Thick Paper..... | 106 |
| Thin Paper..... | 106 |
| Letterhead..... | 107 |
| Label Paper..... | 108 |
| Special Paper..... | 108 |
| Preprinted Paper..... | 109 |
| Color Paper..... | 109 |
| Recycled Paper..... | 109 |
| OHP transparencies..... | 110 |
| Envelopes..... | 110 |
| Storing Paper..... | 113 |
| Non-Recommended Paper Types..... | 114 |
| Print Area..... | 115 |
| Loading Paper in Trays..... | 117 |
| Loading Paper into a Standard or Optional Paper Feed Tray..... | 117 |
| Loading Paper onto Bypass Tray..... | 126 |
| Loading Envelopes..... | 133 |
| Loading Envelopes onto Bypass Tray..... | 133 |
| Loading Envelopes into a Standard or Optional Paper Feed Tray..... | 138 |
| Printing on Fixed-Orientation Paper..... | 145 |
| Registering Unique Names to Paper Types..... | 147 |
| Registering Names to Paper Types..... | 147 |
| Setting User Paper Types to Trays..... | 147 |
| Printing Using Registered Paper Types..... | 148 |

7. Maintaining the Printer

| | |
|--|-----|
| Replacing the Print Cartridge..... | 149 |
| Replacing the Maintenance Kit..... | 154 |
| Cautions When Cleaning..... | 155 |
| Cleaning the Friction Pad and the Paper Feed Roller..... | 156 |
| Cleaning the Registration Roller..... | 159 |

8. Adjusting the Printer

| | |
|----------------------------------|-----|
| Adjusting the Image Density..... | 163 |
| Adjusting Printing Position..... | 165 |
| Adjusting the Paper Type..... | 168 |

9. Troubleshooting

| | |
|--|-----|
| Error and Status Messages Appear on the Control Panel..... | 171 |
| Status Messages (in alphabetical order)..... | 171 |
| Alert Messages (in alphabetical order)..... | 172 |
| Panel Tones..... | 177 |
| Printer Does Not Print..... | 178 |
| Checking the Port Connection..... | 179 |
| Other Printing Problems..... | 181 |
| When You Cannot Print Properly..... | 181 |
| Paper Misfeeds Occur Frequently..... | 183 |
| The printed image is different from the image on the computer..... | 185 |
| When Printer is Not Functioning Properly..... | 186 |
| Additional Troubleshooting..... | 188 |

10. Removing Misfed Paper

| | |
|---|-----|
| When Paper is Jammed..... | 191 |
| Paper Misfeed Message (A)..... | 193 |
| Paper Misfeed Message (B)(C)..... | 197 |
| Paper Misfeed Message (Y1)(Y2)(Y3)(Y4)..... | 202 |
| Paper Misfeed Message (Z1)(Z2)..... | 205 |

11. Appendix

| | |
|---|-----|
| Moving and Transporting the Printer..... | 209 |
| Moving the Printer in a Short Distance..... | 209 |
| Consumables..... | 211 |

| | |
|----------------------|------------|
| Print Cartridge..... | 211 |
| Maintenance Kit..... | 212 |
| Specifications..... | 213 |
| Mainframe..... | 213 |
| Options..... | 216 |
| Trademarks..... | 220 |
| INDEX | 223 |

How to Read This Manual

Symbols

This manual uses the following symbols:

Important

Indicates points to pay attention to when using the machine, and explanations of likely causes of paper misfeeds, damage to originals, or loss of data. Be sure to read these explanations.

Note

Indicates supplementary explanations of the machine's functions, and instructions on resolving user errors.

Reference

This symbol is located at the end of sections. It indicates where you can find further relevant information.

[]

Indicates the names of keys on the machine's display or control panels.

 **Region A** (mainly Europe and Asia)

 **Region B** (mainly North America)

Differences in the functions of Region A and Region B models are indicated by two symbols. Read the information indicated by the symbol that corresponds to the region of the model you are using. For details about which symbol corresponds to the model you are using, see p.7 "Model-Specific Information".

Model-Specific Information

This section explains how you can identify the region your machine belongs to.

There is a label on the front cover of the printer, and it is located in the position shown below. The label contains details that identify the region your machine belongs to. Read the label.

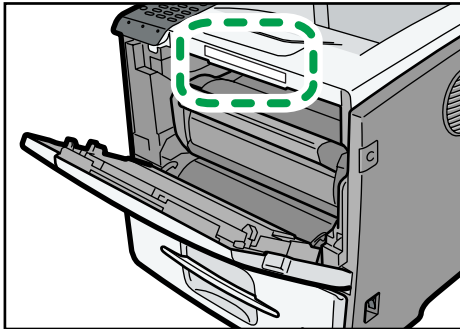

CEC247

The following information is region-specific. Read the information under the symbol that corresponds to the region of your machine.

 **Region A** (mainly Europe and Asia)

If the label contains the following, your machine is a region A model:

- CODE XXXX -22, -27
- 220-240V

 **Region B** (mainly North America)

If the label contains the following, your machine is a region B model:

- CODE XXXX -1 1
- 120-127V

Note

- Dimensions in this manual are given in two units of measure: metric and inch. If your machine is a Region A model, refer to the metric units. If your machine is a Region B model, refer to the inch units.

Machine Types

This printer comes in two models that have different printing speeds.

When describing procedures that are model-specific, this manual refers to the different printer models as Type 1 or Type 2. The following table describes the model types.

Model types

| Model types | Model name |
|-------------|------------|
| Type 1 | SP 5200DN |
| Type 2 | SP 5210DN |

Positions of WARNING and CAUTION Labels

This machine has labels for ⚠WARNING and ⚠CAUTION at the positions shown below. For safety, please follow the instructions and handle the machine as indicated.

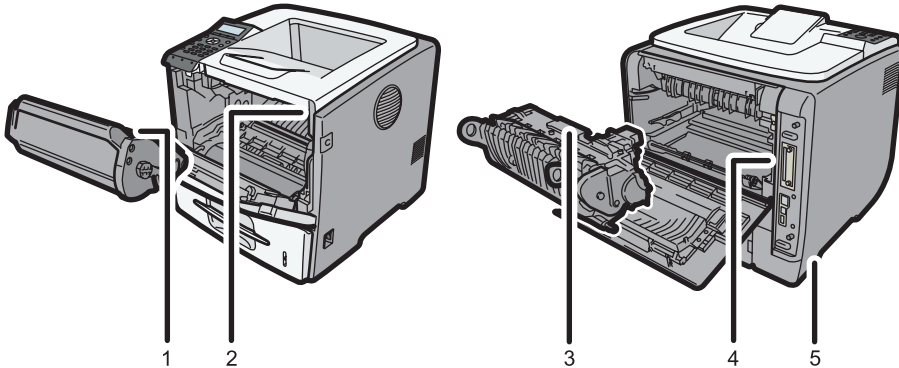

CEC230

1



CEC202

Do not incinerate spilled toner or used toner. Toner dust is flammable and might ignite when exposed to an open flame.

Disposal should take place at an authorized dealer or an appropriate collection site.

If you dispose of the used toner containers yourself, dispose of them according to local regulations.

Keep toner (used or unused) and toner containers out of reach of children.

2

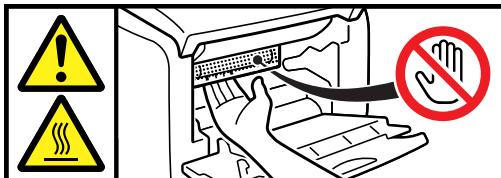

CEC203

Do not put your hands inside the printer. The inside of this printer becomes very hot. Do not touch parts with this label (indicating a hot surface).

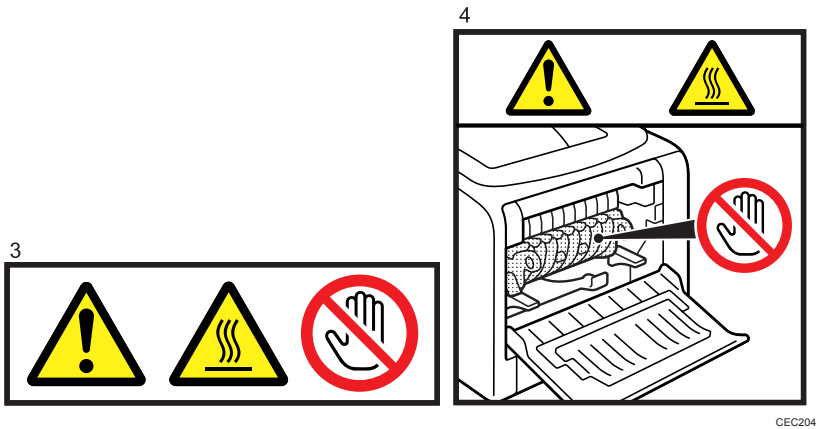

The inside of this printer becomes very hot. Do not touch parts with this label (indicating a hot surface).

5



The printer weighs approximately 23 kg (51 lb.). When moving the printer, use the inset grips on both sides, and lift slowly in pairs.

Power Switch Symbols

The meanings of the symbols for the switches on this machine are as follows:

- I : POWER ON
- O : POWER OFF

Manuals for This Printer

Read this manual carefully before you use this printer.

Refer to the manuals that are relevant to what you want to do with the printer.

★ Important

- Media differ according to manual.
- The printed and electronic versions of a manual have the same contents.
- Adobe Acrobat Reader/Adobe Reader must be installed in order to view the manuals as PDF files.
- A Web browser must be installed in order to view the html manuals.

Safety Information

Contains information about safe usage of this printer.

To avoid injury and prevent damage to the printer, be sure to read this.

Quick Installation Guide

Contains procedures for removing the printer from its box, and connecting it to a computer.

Hardware Guide (This manual)

Contains information about paper; names and functions of the parts of this printer; and procedures such as installing options, replacing consumables, responding to error messages, and resolving jams.

Driver Installation Guide

Contains procedures for installing the printer driver. This manual is included on the driver CD-ROM.

Software Guide

Contains information about using this printer, its software, and its security functions.

Security Guide

This manual is for administrators of the printer. It explains security functions that you can use to prevent unauthorized use of the printer, data tampering, or information leakage. Be sure to read this manual when setting the enhanced security functions, or user and administrator authentication.

VM Card Extended Feature Settings Web Reference

Contains information about setting up the extended features settings using Web Image Monitor.

UNIX Supplement

Contains information about the usage of commands to operate this printer.

To obtain the "UNIX Supplement", visit our Web site or consult an authorized dealer.

This manual includes explanations of functions and settings that might not be available on this printer.

This manual is provided in English only.



↓ Note

- In this manual, "Enhanced Locked Print NX" is abbreviated as "ELP-NX".

-
- Manuals provided are specific to printer types.

List of Options

This section provides a list of options for this printer, and how they are referred to as in this manual.

| Option List | Referred to as |
|---|------------------------------|
| Paper Feed Unit TK1120 | Paper feed unit |
| Paper Feed Unit TK1130 | Paper feed unit with casters |
| Hard Disk Drive Type 2670 | Hard disk |
| Memory Unit Type G 256 MB | SDRAM module |
| Memory Unit Type I 512 MB | SDRAM module |
| Gigabit Ethernet Board Type A | Gigabit Ethernet board |
|  Region B IEEE 802.11a/g Interface Unit Type L | Wireless LAN interface unit |
|  Region A IEEE 802.11a/g Interface Unit Type M | Wireless LAN interface unit |
| IEEE 1284 Interface Board Type A | IEEE 1284 interface board |
| SD card for NetWare printing Type E | NetWare card |
| VM CARD Type O | VM card |
| SD Card for Fonts Type C | SD font card |
| IPDS Unit Type 5200 | IPDS card |

 **Note**

- For details about the specifications of each option, see p.213 "Specifications".

Operating Instructions

This section explains how to use HTML format manuals.

Reading the HTML Manuals on the CD-ROMs

1. Insert the CD-ROM into the CD-ROM drive of your computer.
2. Select a language and a product, and then click [OK].
3. Click [Read HTML manuals].
4. Click the title of manual you want to read.

Note

- The browsers we recommend are Internet Explorer 6 or later, Firefox 3.5 or later, and Safari 4.0 or later.
- Non-recommended browsers can display the simplified manual only.
- If you are using an earlier or non-recommended browser and the simplified version of the documentation does not appear automatically, open index.htm, which can be found in the following folder on the CD-ROM: MANUAL_HTML\LANG\((language)\(manual)\unv
- Depending on your computer's operating environments, you can select the HTML manual from the following two versions:
 - Standard version
 - Simplified version
- If you want to read the HTML manuals on a Macintosh, insert the CD-ROM into the CD-ROM drive, and then click [Read HTML manuals].
- If JavaScript is disabled or unavailable in your browser, you will not be able to search or use certain buttons in the HTML documentation.

Reading the HTML Manuals That You Install on the Computer

For easy access, we recommend you install the manuals on your computer.

1. Insert the CD-ROM into the CD-ROM drive of your computer.
2. Select a language and a product, and then click [OK].
3. Click [Install manuals].
4. Install the HTML manuals following the on-screen instructions.
5. When the installation is complete, click [Finish].
6. Click [Exit].

7. Open the HTML manuals that you installed.

When opening the manuals from an icon, double-click the manual icon on the desktop. When opening the manuals from the [Start] menu, point to [All Programs], and then [Product Name].

8. Click the title of the manual you want to read.

Note

- You need administrator permissions to install the manuals. Log in as an Administrators group member.
- The system requirements for installing the manuals are as follows:
 - Operating system: Windows XP/Vista/7, Windows Server 2003/2003 R2/2008/2008 R2
 - Minimum display resolution: 800 × 600 pixels
- If you cannot install a manual, copy the "MANUAL_HTML" folder to your computer's hard drive, and then run "Setup.exe".
- To delete an installed manual, on the [Start] menu, click [All Programs], then [Product Name], and then uninstall the data.
- Depending on the settings made during installation, menu folder names may differ.



1. Guide to the Printer

This chapter explains the names and functions of the printer's components.

Exterior: Front View

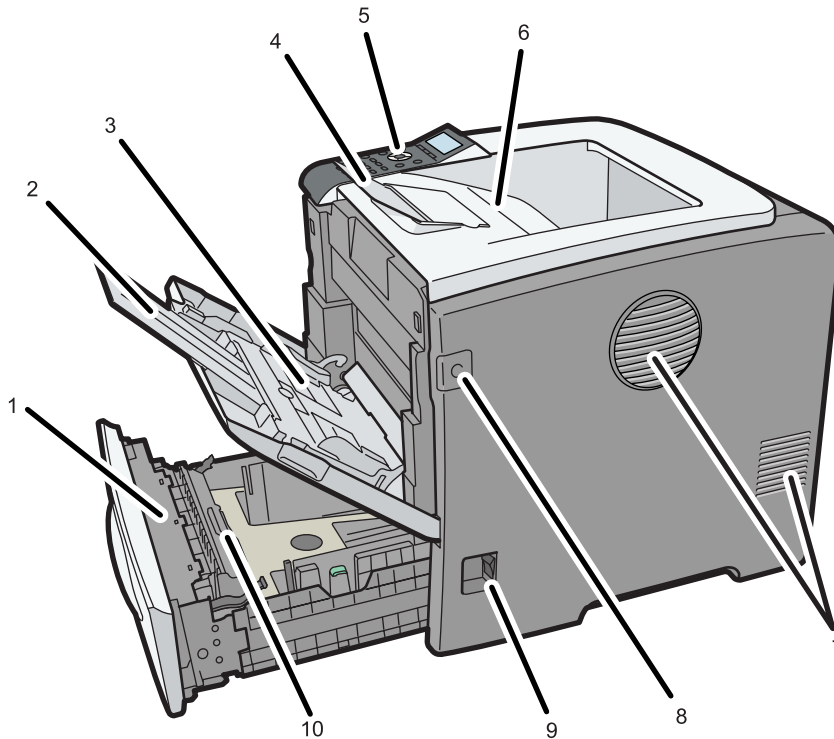

CEC207

1. Standard Paper Feed Tray (Tray 1)

Up to 550 sheets of plain paper can be loaded.

2. Bypass Tray Extension

Pull this out when loading a sheet that is longer than A4[□] and 8 1/2" × 11" (Letter)[□] on the Bypass Tray.

3. Bypass Tray

Up to 100 sheets of plain paper can be loaded.

See p.101 "Supported Paper for Each Tray" and p.101 "Loading Paper".

4. Tray Extension

Raise this barrier to prevent paper from falling off.

5. Control Panel

Contains keys for printer control and a display that shows the printer status.

6. Standard Tray

Prints are delivered here printed side facing down.

7. Vents

To prevent overheating, heat from internal components is released through these vents. Malfunctions and failure can result if these vents are blocked or obstructed.

8. Front Cover Release Button

Press this to open the front cover.

9. Power Switch

Press this to turn the printer's power on and off.

10. Friction Pad

This ensures only one sheet of paper is fed in at a time. If multi-sheet feeds occur, clean the friction pad carefully.

Exterior: Rear View

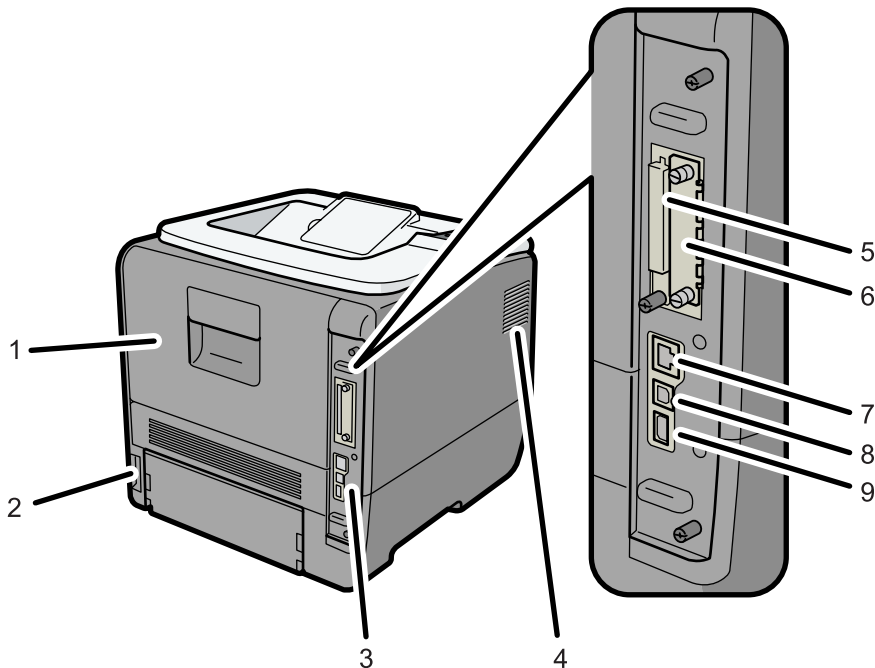

CEC208

1. Rear Cover

Open this cover to replace the fusing unit.

2. Power Connector

Connect the power cord to the printer here. Insert the other end of the cable into a nearby wall outlet.

3. Controller Board

Slide this out to install options such as the SDRAM module or printer hard disk. Plug cables such as a USB cable and Ethernet cable into their connectors.

4. Vents

To prevent overheating, heat from internal components is released through these vents. Malfunctions and failure can result if these vents are blocked or obstructed.

5. SD Card Slots

Remove the cover and install SD cards here.

6. Optional Interface Board Slot

Insert an optional Wireless LAN interface unit, Gigabit Ethernet board, or 1284 interface board in this slot.

7. Ethernet Port

Use a network interface cable to connect the printer to the network.

8. USB Port B

Use a USB cable to connect the printer to a computer.

9. USB Port A

Use a USB cable to connect the optional USB devices such as the authentication card reader.

Interior

Front view

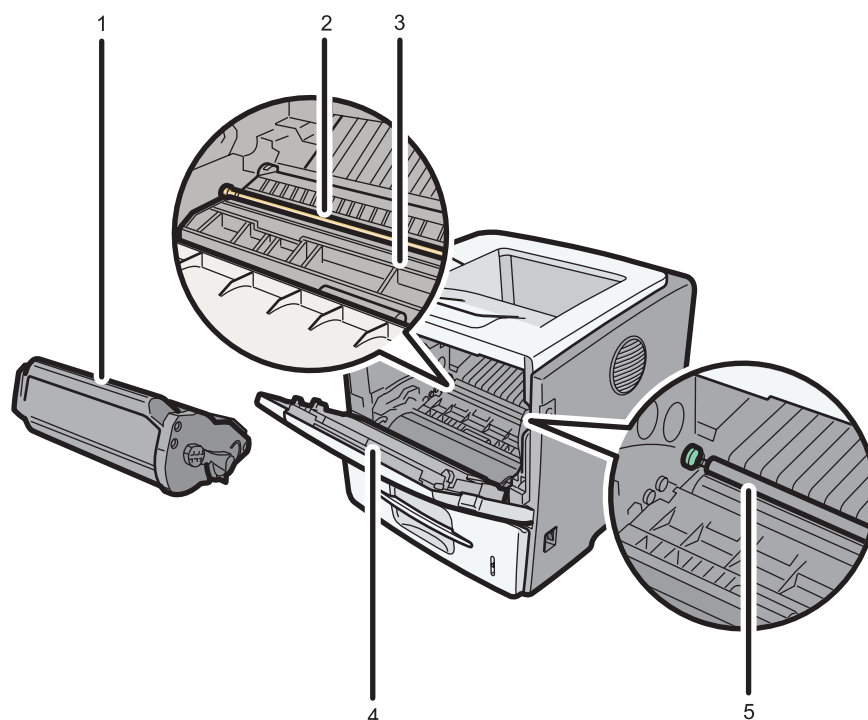

CEC209

1. Print Cartridge

Contains toner and the photo conductor unit.

When "Replace Print Cartridge." appears on the display, replace this unit.

2. Registration Roller

Feeds in sheets of paper for printing. Be sure to clean this roller if it becomes dirty or replace the print cartridge.

See p. 159 "Cleaning the Registration Roller".

3. Guide Board

Open this to remove jammed paper.

4. Front Cover

Open this to access the printer's interior.

5. Transfer Roller

When "Replacmnt Requir:Maint. Kit" appears on the display, replace this roller.

Rear view

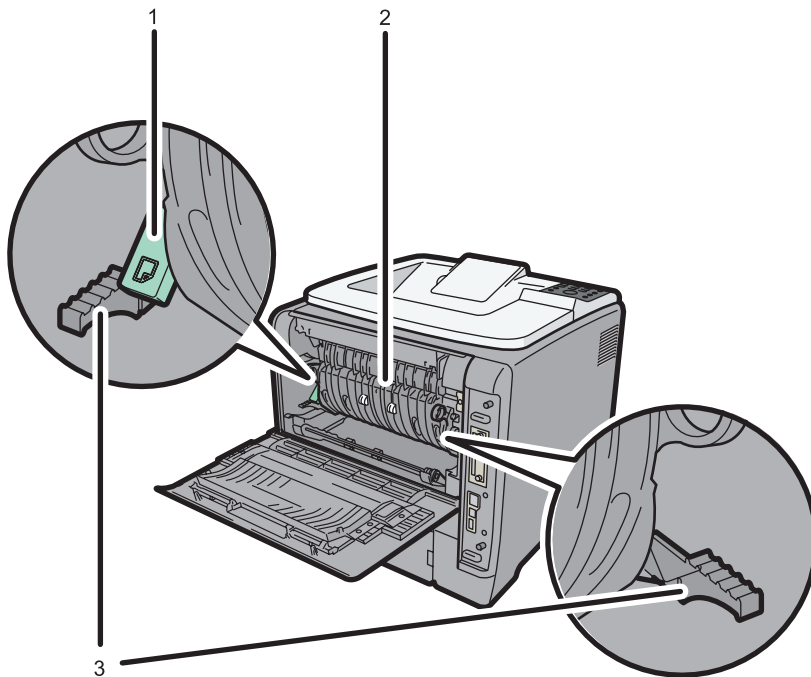

CEC231

1. Envelope lever

Use this lever if envelopes become wrinkled during printing. Raising or lowering the envelope lever according to the thickness of the paper you are printing on can improve print quality.

2. Fusing Unit

Fuses print images onto paper.

When "Replacmnt Requ:d:Maint. Kit" appears on the display, replace this unit.

3. Fusing Unit Lock Levers

Lift these levers to replace the fusing unit.

Control Panel

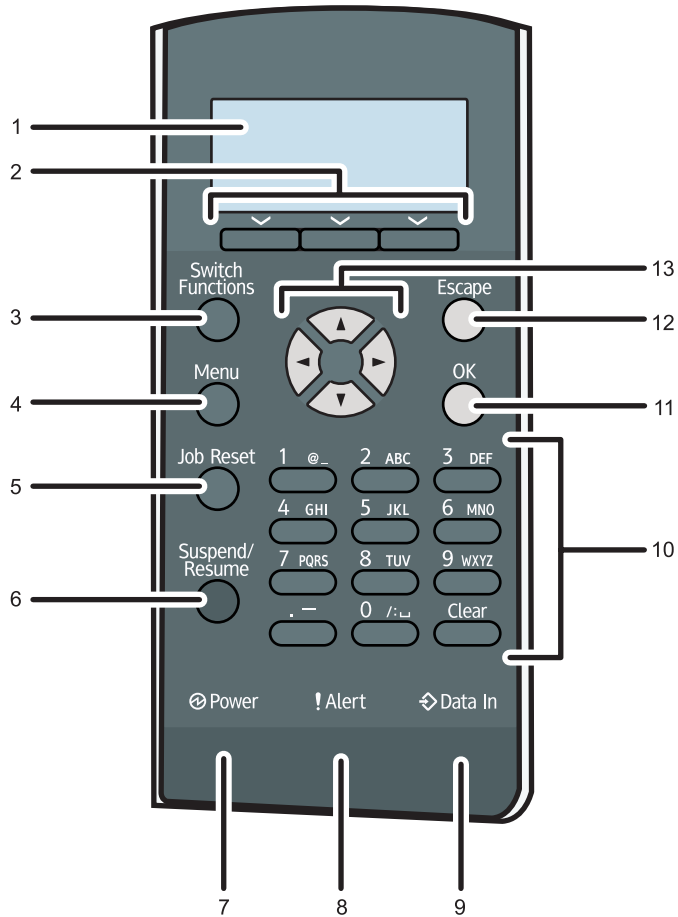

CEC210

1. Display

Displays current printer status and error messages.

Entering energy saver mode turns off the back light. For details about energy saver mode, see Software Guide.

2. Selection Keys

Correspond to the function items at the bottom line on the display.

Example: When this manual instructs you to press [Option], press the selection key on the left below the initial screen.

3. [Switch Functions] Key

Press this key to switch between the operation screen of the printer function and the function screens of the extended features currently in use.

4. [Menu] Key

Press this key to configure and check the current printer settings.

5. [Job Reset] Key

When the printer is online, press this key to cancel an ongoing print job.

6. [Suspend/Resume] Key

Press this to suspend the print job currently being processed. The indicator remains lit as long as the job is suspended.

To resume the job, press this key again. Resumption of a suspended job will occur automatically when the time specified in [Auto Reset Timer] elapses (default: **60 seconds**).

For details about the [Auto Reset Timer] setting, see "Making Printer Settings Using the Control Panel", Software Guide.

7. Power Indicator

Lights up when the printer is ready to receive data from a computer. Flashes when the printer is warming up or receiving data. It is unlit when the power is off or while the printer is in energy saver mode.

8. Alert Indicator

Lights up or flashes when a printer error occurs.

Steady red: printing is not possible, or is possible but print quality cannot be ensured.

Flashing yellow: the printer will soon require maintenance or a replacement consumable such as print cartridge.

Follow the instructions that appear on the display.

9. Data In Indicator

Flashes when the printer is receiving data from a computer. The data in indicator is lit if there is data to be printed.

10. Number Keys

Use these to enter characters or numbers.

11. [OK] Key

Use this key to confirm settings, or setting values, or move to the next menu level.

12. [Escape] Key

Press this key to cancel an operation or return to the previous display.

13. Scroll Keys

Press these keys to move the cursor in each direction.

When the [▲] [▼] [◀] [▶] keys appear in this manual, press the scroll key of the same direction.

Display Panel

The items are highlighted when selected.

★ Important

- Do not touch the display panel.

The following screen appears when you turn on the printer.

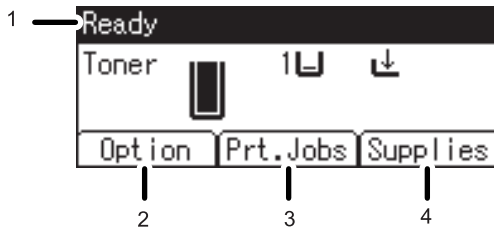

CEC235

1. Operational Status or Messages

Displays the printer status or the messages.

2. [Option]

Press to display the following items:

- Form Feed
- Error Log

3. [Prt.Jobs]

Press to display print jobs sent from a computer.

4. [Supplies]

Press to display the information of supplies for the printer.

↓ Note

- [Prt.Jobs] is displayed only when the hard disk is installed in the printer.
- By default, the remaining amount of toner is displayed. To not display the remaining amount of toner, press the [Menu] key, and then select [Maintenance] on the display. Select [General Settings], then [Display Supply Info], and then select [Off].
- Adjust the brightness if the screen is dark. To adjust the display contrast, press the [Menu] key, and then select [Maintenance] on the display. Select [General Settings] and then [Display Contrast].

Entering Characters

When you enter a character, it will be displayed at the position indicated by the cursor. If a character is already displayed at the cursor position, the entered character will be displayed before that.

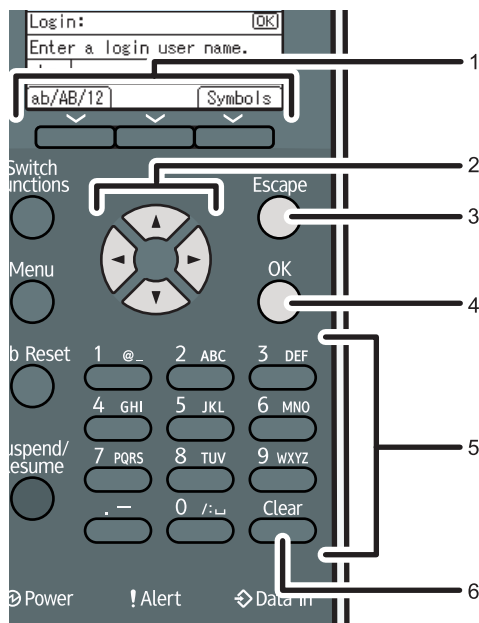

CEC212

1. Selection Keys

Correspond to the function items on the bottom line of the display.

Example: When this manual instructs you to press [ab/AB/12], press the selection key on the left below the text input screen.

Press the left selection key to switch the input mode between lowercase, uppercase, and numeric characters.

Press the right selection key to display a list of the symbols that you can enter.

2. Scroll Keys

Press to move the cursor in each direction.

When the [▲] [▼] [◀] [▶] keys appear in this manual, press the scroll key showing the same direction.

3. [Escape] Key

Clears the entered text and numbers, and returns the display to its previous state.

4. [OK] Key

Confirms the entered text and numbers, and displays the next menu.

5. Number Keys

To enter text using the number keys, select text input mode by pressing [ab/AB/12].

When you press a number key repeatedly, the character changes in the order indicated above the key you are pressing.

6. [Clear] Key

Deletes the character at the cursor position. You can delete a character at the far right side of a line even if the cursor is placed to the right of the character.

1

How to Enter Characters

Use the following procedure to enter text in the text input screen. ("User#2" is the text entered in this example.)

1. Press [ab/AB/12] to change the input mode to uppercase.

| | |
|--------------------------|---------|
| Login: | [OK] |
| Enter a login user name. | |
| abc | |
| ab/AB/12 | Symbols |

2. Press the [8 TUV] key twice, and then press the [▶] key. A letter "U" is entered.

| | |
|--------------------------|---------|
| Login: | [OK] |
| Enter a login user name. | |
| ABC | U |
| ab/AB/12 | Symbols |

3. Press [ab/AB/12] two more times to change the input mode to lowercase.

| | |
|--------------------------|---------|
| Login: | [OK] |
| Enter a login user name. | |
| abc | U_ |
| ab/AB/12 | Symbols |

4. Press the [7 PQRS] key four times, and then press the [▶] key. A letter "s" is entered.

| | |
|--------------------------|---------|
| Login: | [OK] |
| Enter a login user name. | |
| abc | Us |
| ab/AB/12 | Symbols |

5. Press the [3 DEF] key twice, and then press the [►] key. A letter "e" is entered.

| | |
|--------------------------|---------|
| Login: | [OK] |
| Enter a login user name. | |
| abc Use | |
| ab/AB/12 | Symbols |

6. Press the [7 PQRS] key three times, and then press the [►] key. A letter "r" is entered.

| | |
|--------------------------|---------|
| Login: | [OK] |
| Enter a login user name. | |
| abc User | |
| ab/AB/12 | Symbols |

7. Press [Symbols] to display a list of the symbols you can enter.

| | |
|--------------------------|---------|
| Login: | [OK] |
| Enter a login user name. | |
| abc User | |
| ab/AB/12 | Symbols |

8. Use the scroll keys to select "#", and then press the [OK] key.

| | | | |
|--------------------|-----|----|------|
| Symbols: | 1/2 | ◀▶ | [OK] |
| ! " # \$ % & ' () | | | |
| * + , - . / : ; < | | | |
| = > ? @ [\] ^ _ | | | |

The list of symbols disappears and a "#" symbol is entered.

| | |
|--------------------------|---------|
| Login: | [OK] |
| Enter a login user name. | |
| abc User# | |
| ab/AB/12 | Symbols |

9. Press [ab/AB/12] two more times to change the input mode to numeric.

| | |
|--------------------------|---------|
| Login: | [OK] |
| Enter a login user name. | |
| 123 User# | |
| ab/AB/12 | Symbols |

10. Press the [2 ABC] key. A number "2" is entered.

| | |
|--------------------------|---------|
| Login: | [OK] |
| Enter a login user name. | |
| 123 | User#2_ |
| ab/AB/12 | Symbols |

11. Press the [OK] key to proceed to the next menu.

2. Setting Up the Printer

This chapter explains how to set up and configure the printer for operation.

Printer Setup Procedure

Use the following procedure to set up the printer.

2

1. Select a suitable location for your printer.

For details, see p.32 "Place to Install".

2. Take the printer out of its box, and then remove the protective materials and adhesive tape.

For details, see p.36 "Unpacking".

3. Load paper in the standard paper feed tray.

For details, see p.117 "Loading Paper in Trays".

4. Turn the printer power on.

For details, see p.39 "Turning the Printer's Power On and Off".

5. Select the language used on the display.

For details, see p.43 "Selecting the Display Language".

6. Print a test page.

For details, see p.44 "Test Printing".

7. Connect the printer to your network.

For details, see p.69 "Connecting the Printer".

8. Configure the printer's network settings.

For details, see p.75 "Configuration".

9. Install the printer driver.

For details, see Driver Installation Guide.

Place to Install

The printer's location should be carefully chosen because environmental conditions greatly affect its performance.

WARNING

- Do not use any frequencies other than those that match the specifications shown. Doing so could result in fire or electric shock.

WARNING

- Do not use any power sources other than those that match the specifications shown in "Safety Information". Doing so could result in fire or electric shock.

WARNING

- Do not use multi-socket adaptors. Doing so could result in fire or electric shock.

WARNING

- Do not use extension cords. Doing so could result in fire or electric shock.

WARNING

- Do not use power cords that are damaged, broken, or modified. Also, do not use power cords that have been trapped under heavy objects, pulled hard, or bent severely. Doing so could result in fire or electric shock.

WARNING

- Touching the prongs of the power cable's plug with anything metallic constitutes a fire and electric shock hazard.

WARNING

- The supplied power cord is for use with this machine only. Do not use it with other appliances. Doing so could result in fire, electric shock, or injury.

WARNING

- It is dangerous to handle the power cord plug with wet hands. Doing so could result in electric shock.

⚠ WARNING

- If the power cord is damaged and its inner wires are exposed or broken, contact your service representative for a replacement. Use of damaged power cords could result in fire or electric shock.

⚠ WARNING

- Be sure to locate the machine as close as possible to a wall outlet. This will allow easy disconnection of the power cord in the event of an emergency.

⚠ WARNING

- Do not use flammable sprays or solvents in the vicinity of this machine. Doing so could result in fire or electric shock.

⚠ CAUTION

- Keep the machine away from humidity and dust. Otherwise a fire or an electric shock might occur.

⚠ CAUTION

- Do not place the machine on an unstable or tilted surface. If it topples over, an injury might occur.

⚠ CAUTION

- Make sure the room where you are using the machine is well ventilated and spacious. Good ventilation is especially important when the machine is used heavily.

⚠ CAUTION

- Keep the machine away from salt-bearing air and corrosive gases. Also, do not install the machine in places where chemical reactions are likely (laboratories, etc.), as doing so will cause the machine to malfunction.

⚠ CAUTION

- Be sure to disconnect the plug from the wall outlet and clean the prongs and the area around the prongs at least once a year. Allowing dust to build up on the plug constitutes a fire hazard.

⚠ CAUTION

- Machine sound levels exceeding [Sound Power Level (Black and White)] > 63 dB (A) are not suitable for desk work environments, so place the machine in another room.

⚠ CAUTION

- When new, electrical devices containing volatile materials will normally release emissions into the air of their vicinity. For this reason, for the first few days after installation of a new device, strong ventilation inside the room where it is placed is necessary.

2

Space Required for Installation

The recommended (or minimum) space requirements are as follows:

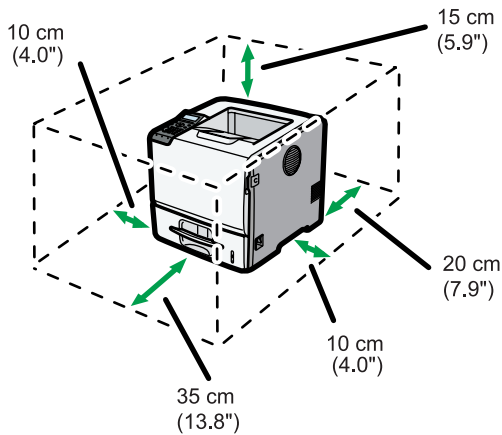

CEC213

Optimum Environmental Conditions

Permissible and recommended temperature and humidity ranges are as follows:

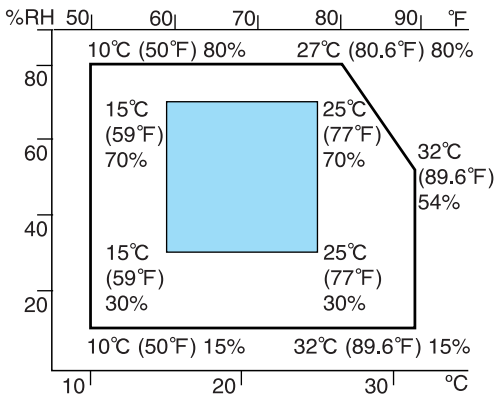

CBK019

- White area: Permissible Range
- Blue area: Recommended Range

↓ Note

- The printer must be level within 5 mm, 0.2" from both front to rear and left to right.

- When you use this printer for a long time in a confined space without good ventilation, you may detect an odd smell. To keep the workplace comfortable, we recommend you keep it well ventilated.

Ventilation

When you use this machine in a confined space without good ventilation for a long time or print large quantities, you might detect an odd smell.

This might cause the output paper to also have an odd smell.

When you detect an odd smell, regularly ventilate in order to keep the workplace comfortable.

- Set up the machine so that it does not directly ventilate towards people.
- Ventilation should be more than 30 m³/hr/person.

New machine smell

When a machine is new, it might have a unique smell. This smell will subside in about one week.

When you detect an odd smell, sufficiently ventilate and circulate the air in the room.

Environments to Avoid

Do not use the printer in the following environments:

★ Important

- Areas exposed to direct sunlight or strong light
- Dusty areas
- Areas with corrosive gases
- Areas that are excessively cold, hot, or humid
- Areas directly exposed to currents of hot, cold, or room-temperature air from air conditioners
- Areas directly exposed to radiant heat from heaters
- Locations near air conditioners, heaters, or humidifiers
- Locations near other electronic equipment
- Locations subject to frequent strong vibration

Power Source

Connect the power cord to a power source of the following specification:

 **Region A** (mainly Europe and Asia)
220 - 240 V, 50/ 60 Hz, 6 A or more

 **Region B** (mainly North America)
120 - 127 V, 60 Hz, 11 A or more

Unpacking

To protect it from shock and vibration during transit, this printer comes packaged in cushioning foam and secured with tape. Remove these protective materials after bringing the machine to where it will be installed.

WARNING

- Keep the polythene materials (bags, etc.) supplied with this machine away from babies and small children at all times. Suffocation can result if polythene materials are brought into contact with the mouth or nose.

WARNING

- Do not incinerate toner (new or used) or toner containers. Doing so risks burns. Toner will ignite on contact with naked flame.

CAUTION

- Do not crush or squeeze toner containers. Doing so can cause toner spillage, possibly resulting in dirtying of skin, clothing, and floor, and accidental ingestion.

CAUTION

- Store toner (new or used), toner containers, and components that have been in contact with toner out of reach of children.

CAUTION

- If toner or used toner is inhaled, gargle with plenty of water and move into a fresh air environment. Consult a doctor if necessary.

CAUTION

- If toner or used toner gets into your eyes, flush immediately with large amounts of water. Consult a doctor if necessary.

CAUTION

- If toner or used toner is swallowed, dilute by drinking a large amount of water. Consult a doctor if necessary.

CAUTION

- When lifting the machine, use the inset grips on both sides. The printer could break or cause an injury if dropped.

★ Important

- Removed tape is dirty. Be careful not to let it touch your hands or clothes.
- Do not grip on the tray area when lifting the printer.
- Do not allow paper clips, staples, or other small metallic objects to fall inside the printer.
- Keep the uncovered print cartridge away from direct sunlight.
- When you use this printer for the first time, use the print cartridge packaged with the printer.

↓ Note

- Print cartridge (consumables) are not covered by warranty. However, if there is problem, contact the store where they were purchased.

1. Remove the plastic bag.**2. Lift the printer with two people by using the inset grips on both sides of the printer.**

Leave the tape holding the paper feed tray and cover in place while moving the printer. Lower the machine slowly and carefully to prevent trapping your hands.

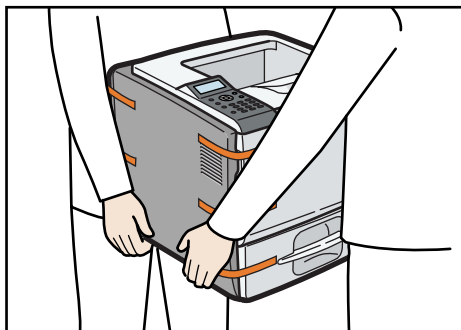

CEC292

When moving the printer, do not hold on the following parts as doing so could cause a malfunction:

- The handle onto the standard paper feed tray.
- The underside of the bypass tray.

3. Remove the adhesive tape.

4. Open the front cover by pushing the front cover release button.

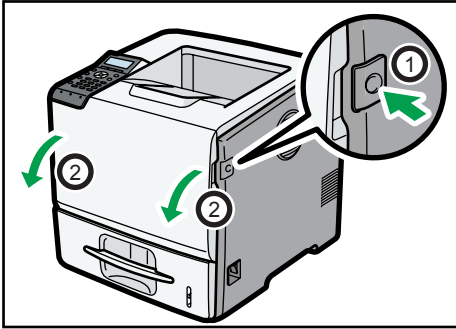

CEC025

5. Remove the fixing material and adhesive tape.

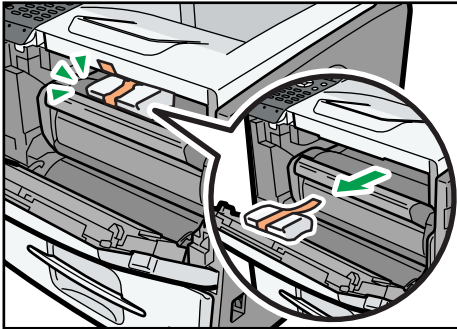

CEC226

6. Close the front cover.

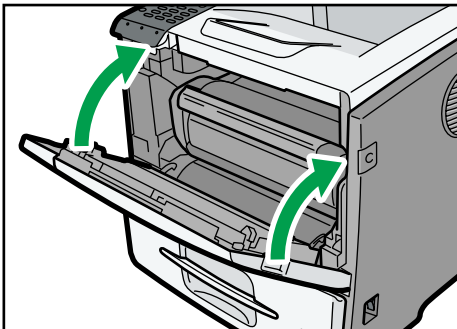

CEC214

Turning the Printer's Power On and Off

⚠ WARNING

- It is dangerous to handle the power cord plug with wet hands. Doing so could result in electric shock.

★ Important

- Do not turn off the power switch before following the shutdown procedure shown here. Doing so can result in damage to the hard disk or memory, leading to malfunction.
- Do not physically disturb the printer while printing is in progress. Doing so may damage the printer.

2

Turning on the Power

★ Important

- Make sure the power cord is plugged securely into the wall outlet.
- Turn the power switch off when plugging and unplugging the power plug.
- Do not turn off the power switch until initializing is completed. Doing so results in malfunction.

1. Make sure the power switch is set to "○ Off".

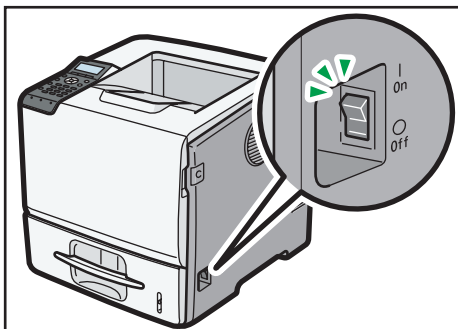

CEC056

2. Plug in the power cable, and securely insert the plug of the power cord into the wall socket.

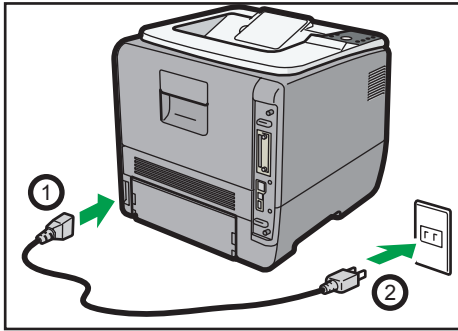

CEC057

3. Turn the power switch to "I On".

The power indicator on the control panel lights up.

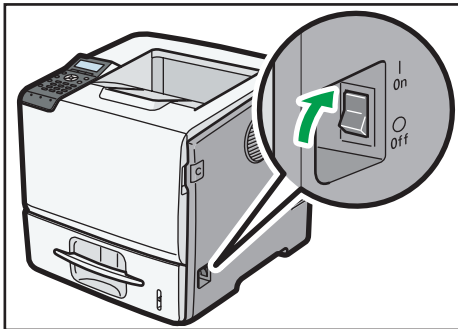

CEC058

Note

- Wait until "Ready" appears on the display panel.
- The printer may make a noise while initializing. This noise does not indicate a malfunction.

Turning off the Power

1. Press the [Menu] key.

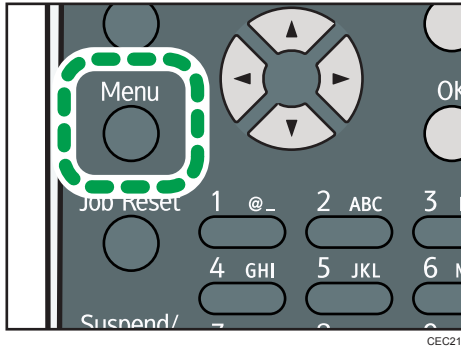

2

2. Press the [▼] or [▲] key to select [Shutdown], and then press the [OK] key.

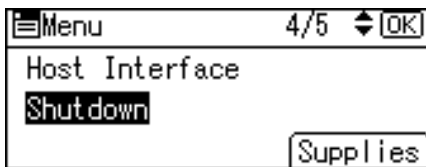

3. Press [Yes].

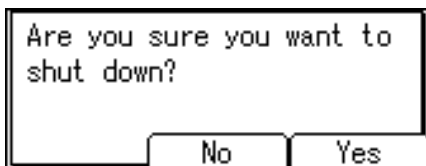

4. Wait until a screen prompting you to turn off the main power appears, and then turn the power switch to "O Off".

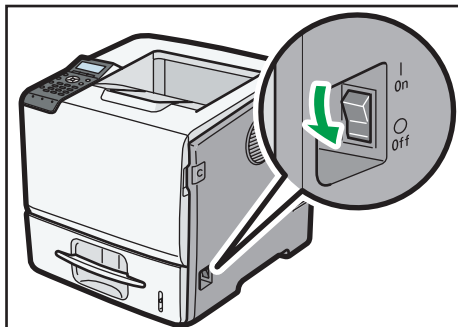

↓ Note

- Even if you follow the shutdown procedure, the printer might not shutdown in the following cases:
 - If it is communicating with external devices.

- If the hard disk is active.
- If the printer's cover is opened.

Selecting the Display Language

1. Press the [Menu] key.

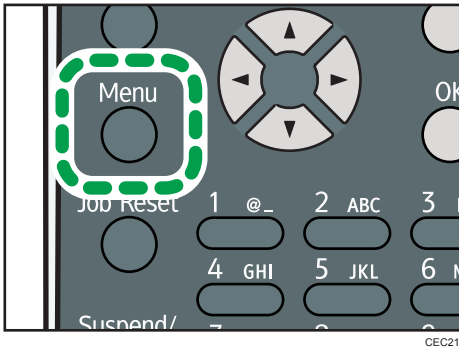

2

2. Press the [▼] or [▲] key to select [Language], and then press the [OK] key.

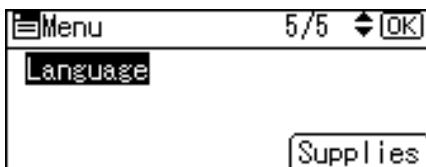

3. Press the [▼] or [▲] key to select the preferred language, and then press the [OK] key.

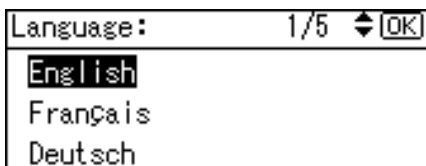

4. Press the [Menu] key to return to the initial screen.

↓ Note

- The default setting is English.

Test Printing

Print a test print in order to verify that the printer is working normally. Test printing checks printer performance only; it does not test the connection to the computer.

1. Press the [Menu] key.

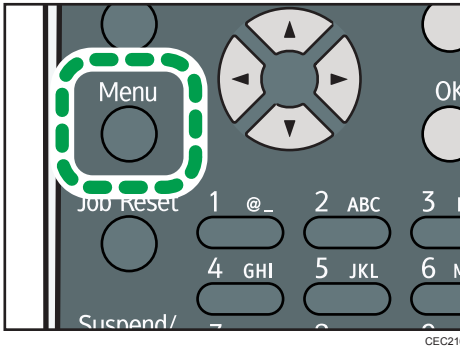

2. Press the [▼] or [▲] key to select [List/Test Print], and then press the [OK] key.



3. Press the [▼] or [▲] key to select [Config. Page], and then press the [OK] key.



4. Press the [Menu] key to return to the initial screen.

↓ Note

- If printing is not normal, check to see if an error message appears on the display. If there is an error message, see p.171 "Troubleshooting".

3. Installing Options

This chapter explains how to install various options for this printer.

Available Options

By installing options, you can improve printer performance and expand the available features.

CAUTION

- Before installing or removing options, always disconnect the power cord plugs from the wall outlet and allow time for the main unit to fully cool. Failing to take these precautions could result in burns.

3

Order of Option Installation

When installing multiple options, the following order is recommended:

1. Attach the paper feed unit.

Attach the paper feed unit to the bottom of the printer.

You can attach up to four paper feed unit. Up to 2850 sheets of paper can be loaded in total.

2. If you are using Type 1 model, install the SDRAM module.

Install the expansion memory in the controller board slot.

There are two types of SDRAM module, 256 MB and 512 MB.

3. If you are using Type 1 model, install the hard disk.

4. Install the optional interface board.

Install the optional Gigabit Ethernet board, Wireless LAN interface unit, or IEEE 1284 interface board in the slot.

5. Insert SD card options.

Install the SD card supplied with the optional hard disk (Type 1 model only), NetWare card, SD font card, VM card, or IPDS card.

Insert these units into the SD card slot.

If you want to use two or more SD cards that can be inserted in the same slot, contact your sales and service representative.

Where to Install Options

External options

- Paper feed unit

Loads up to 550 sheets of paper. Up to four paper feed unit can be installed on the printer. Installed tray unit is identified as "Tray 2", "Tray 3", "Tray 4", and "Tray 5".

There are two types of the optional paper feed unit: the one with casters on its bottom side, and the one without casters. To set the printer directly on the floor, attach the optional paper feed unit with casters to the bottom of the printer.

For details about attaching the paper feed unit, see p.48 "Attaching the Paper Feed Unit".

Internal options

3

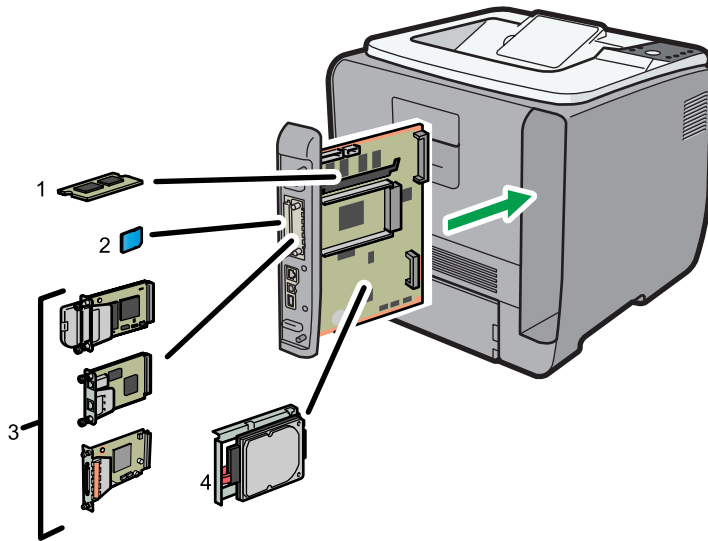

CEC074

1. SDRAM module

For details about this option, see p.55 "Installing the SDRAM Module".

2. SD card options

For details about installing these options, see p.66 "Installing the SD Memory Card Options".

3. Optional interface boards

- Wireless LAN interface unit
- Gigabit Ethernet board
- IEEE 1284 interface board

For details about installing these options, see p.59 "Installing the Interface Units".

4. Hard disk

For details about this option, see p.52 "Installing the Hard Disk".

↓ Note

- For details about the specifications of each option, see p.213 "Specifications".

Caution When Re-installing the Controller Board

This section describes how to handle the controller board when installing options.

If you slide out the controller board to install units, carefully read the instructions about re-installing the controller board.

★ Important

- The following may occur if the controller board is not properly installed:
 - All control panel indicators light up.
 - No control panel indicators light up.
 - An error message appears on the display.

Push the bottom center area of the board to re-install the controller board in the printer.

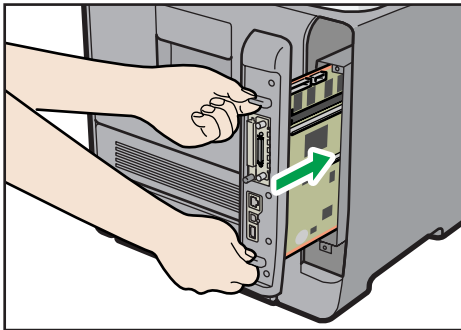

CEC076

Attaching the Paper Feed Unit

WARNING

- If the machine topples, or if a cover or other part gets broken, you must turn the power switch to off and disconnect the power cord plug from the wall outlet. Then contact your service representative and report the problem. Do not use the machine. Doing so could result in fire or electric shock.

3

CAUTION

- The printer weighs approximately 23 kg (51 lb.). When moving the printer, use the inset grips on both sides, and lift slowly. The printer will break or cause injury if dropped.

CAUTION

- Unplug the power cord from the wall outlet before you move the machine. While moving the machine, take care that the power cord is not damaged under the machine. Failing to take these precautions could result in fire or electric shock.

CAUTION

- Do not place the machine on an unstable or tilted surface. If it topples over, an injury might occur.

CAUTION

- Lifting the paper feed unit carelessly or dropping it may cause injury.

CAUTION

- The printer might topple over and cause damage and injuries if four optional paper feed units are stacked to a printer which is installed directly on the floor. For details about preventing the machine toppling over, contact your service representative.

Important

- The printer should always be lifted by two people.
- Do not grip on the tray area when lifting the printer.
- When four paper feed units are installed, they are detected as "Tray 2", "Tray 3", "Tray 4", and "Tray 5", starting from the upper unit.
- The same procedure applies when attaching the optional paper feed unit with casters.
- The number of optional trays that can be attached differs depending on the location where the printer is installed.

- If the printer is installed on a desk or other elevated surface, up to three optional paper feed units can be stacked (①). If the printer is installed directly on the floor, up to four optional paper feed units can be stacked (②).

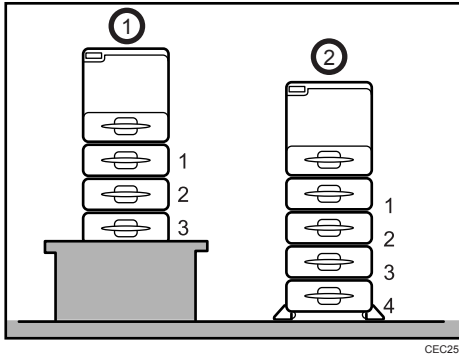

- To install the printer directly on the floor, stack the optional paper feed unit with casters to the bottom of the printer.

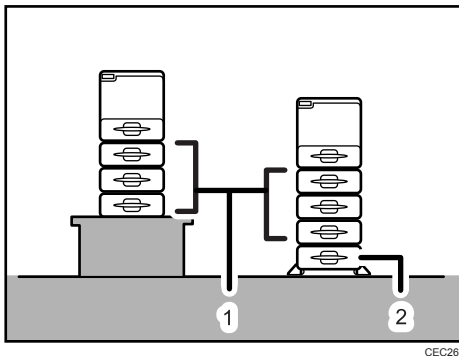

1. Paper feed unit
2. Paper feed unit with casters

1. Check the package contains the following:

1

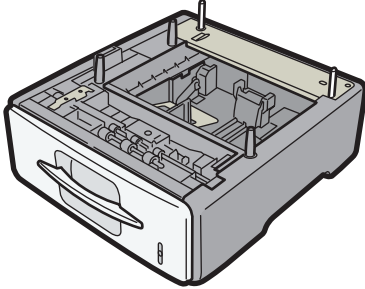

2

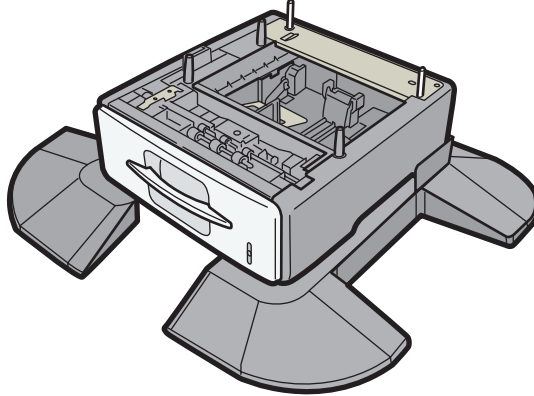

CEC256

3

1. Paper feed unit (including a paper tray)
2. Paper feed unit with casters (including a paper tray)
2. Turn off the printer's power switch, and then unplug the printer's power cord from the wall outlet.
3. Remove the adhesive tape from the optional paper feed unit.
4. Lift the printer using the inset grips on both sides of the printer.

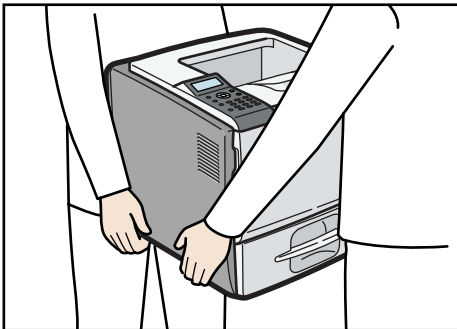

CEC045

When moving the printer, do not hold on the following parts as doing so could cause a malfunction:

- The handle onto the standard paper feed tray.
- The underside of the bypass tray.

5. There are five upright pins on the optional paper feed unit. Align them with the holes on the underside of the printer, and then carefully lower the printer.

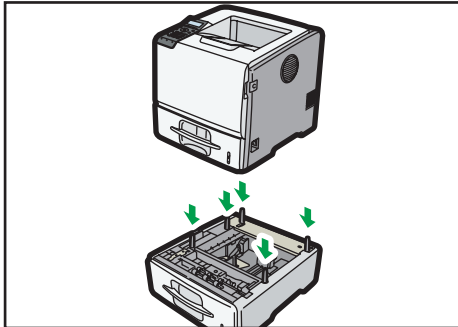

CEC039

6. After installing the option, print the configuration page to confirm the installation.

Note

- When moving the printer, remove the paper feed unit.
- After finishing the installation, you can check whether the paper feed unit is properly installed by printing the configuration page from the [List/Test Print] menu. If the paper feed unit is properly installed, "Tray 2", "Tray 3", "Tray 4", and "Tray 5" will appear for "Attached Equipment" on the configuration page.
- If the paper feed unit is not installed properly, reinstall it following this procedure. If you cannot install it properly even after attempting reinstallation, contact your sales or service representative.
- If the print area is not centered correctly, adjust the printing position for the optional paper feed unit. For details, see p. 165 "Adjusting Printing Position".
- For details about printing the configuration page, see p.44 "Test Printing".
- For details about loading paper onto the paper tray, see p. 117 "Loading Paper in Trays".
- After a new paper feed unit has been installed, the driver settings might need to be reconfigured. For details, see "Making Option Settings for the Printer", Driver Installation Guide.

Installing the Memory Expansion Units

The following procedure applies to Type 1 model only.

⚠ CAUTION

- Do not touch the inside of the controller board compartment. Doing so may cause a machine malfunction or a burn.

3

Installing the Hard Disk

★ Important

- Before touching the hard disk, touch something metal to discharge any static electricity. Static electricity can damage the hard disk.
- Do not subject the hard disk to physical shocks.

1. Check the package contains the following:

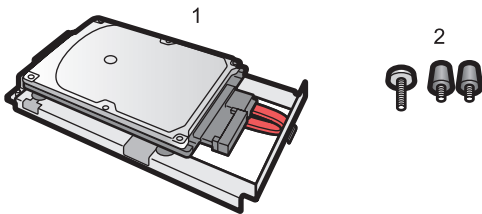

CEC015

1. Hard disk

2. Screws

2. Turn off the power to the printer, and then unplug the power cable and interface cable.
3. Remove the two screws holding the controller board in place.

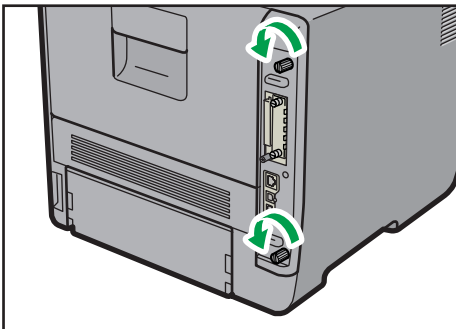

CEC073

The removed screws are required to fasten the controller board.

4. Gripping the handles, carefully pull out the controller board.

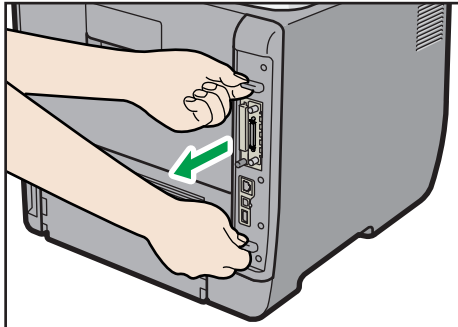

CEC075

5. Place the controller board on a flat surface.

The hard disk is installed in the slot shown in the illustration below.

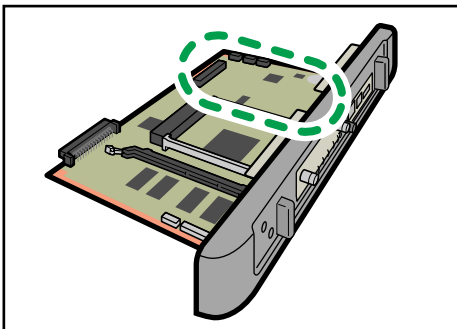

CEC019

6. Insert the protrusion on the front end of the hard disk board into the notch on the back panel of the controller board.

Be sure to set the hard disk board parallel with the controller board.

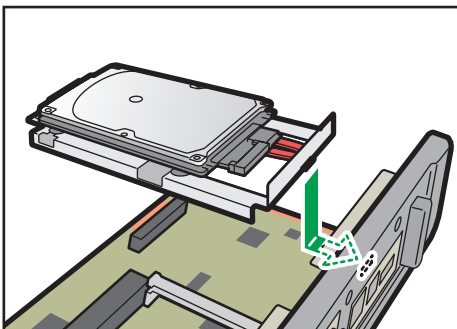

CEC016

7. Fit the hard disk on the connector of the controller board carefully until it stops.

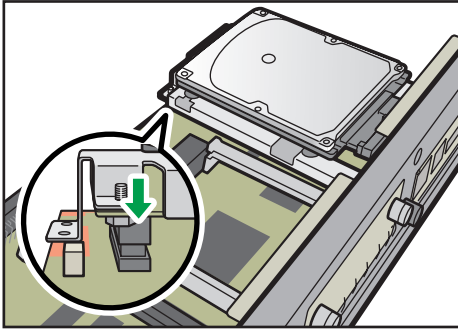

CEC017

8. Tighten the two screws by turning them clockwise with a coin, and then secure the hard disk board by tightening the third screw from the under side of the controller board.

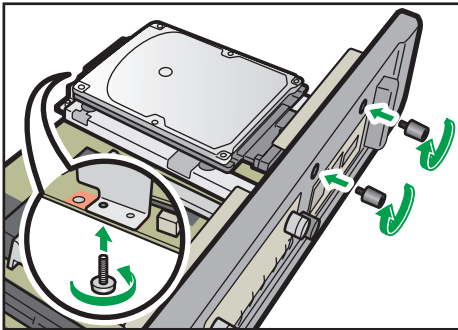

CEC018

9. To install other options on the controller board, follow the installation procedure shown in the documentation provided with the option.
10. Align the controller board with the top and bottom rails, and then push it carefully in, until it stops.

The printer may malfunction if the controller board is not properly installed.

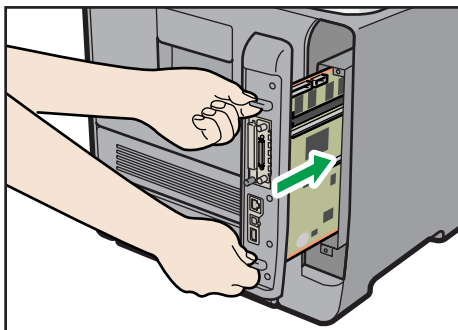

CEC076

11. Fasten the controller board to the printer with the two screws.

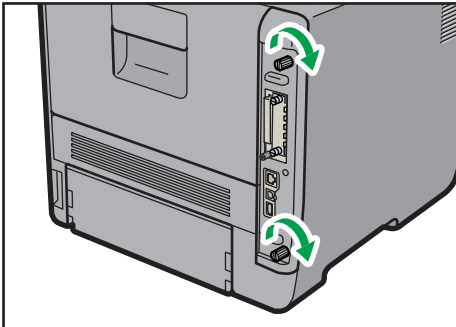

CEC072

First install the optional hard disk, and then install the SD card provided with the hard disk. For details about the installation procedure, see p.66 "Installing the SD Memory Card Options".

↓ Note

- After finishing installation, you can check whether the hard disk is properly installed: Print the configuration page from the [List/Test Print] menu. If it is installed properly, you will see "Hard Disk" will appear for "Device Connection" on the configuration page.
- If the Hard disk is not properly installed, repeat this procedure. If you cannot install it properly even after reinstallation, contact your sales or service representative.
- For details on printing the configuration page, see p.44 "Test Printing".

Installing the SDRAM Module

★ Important

- Before touching the SDRAM module, ground yourself by touching something metal to discharge any static electricity. Static electricity can damage the SDRAM module.
 - Do not subject the SDRAM module to physical shocks.
 - The printer comes equipped with 256 MB of memory. This can be expanded to a maximum of 768 MB.
1. Turn off the power of the printer, and then unplug the power cable and interface cable.

2. Remove the two screws holding the controller board in place.

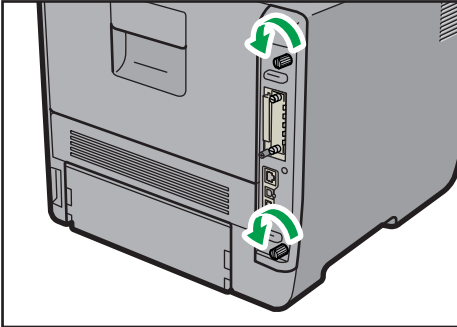

CEC073

The removed screws are required to fasten the controller board.

3. Gripping the handles, carefully pull out the controller board.

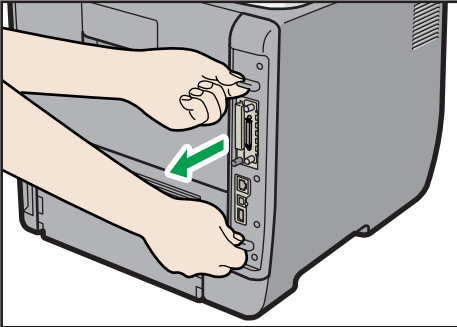

CEC075

4. Place the controller board on a flat surface.

The SDRAM module is installed in the slot shown in the illustration below.

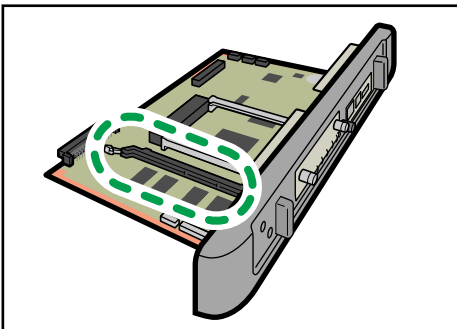

CEC012

5. To install the recommended memory, align the notch of the recommended memory with the protruding part of the vacant slot, and then carefully insert the module at an angle.

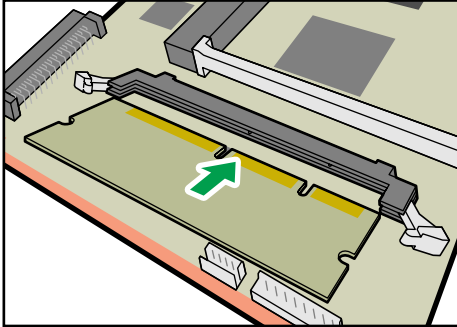

CEC013

6. Keeping the module at an angle, press it down until it clicks into place.

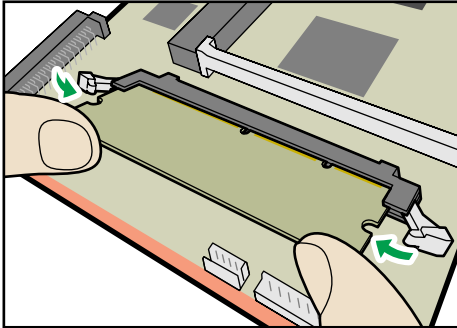

CEC014

7. Align the controller board with the top and bottom rails, and then push it carefully in, until it stops.

The printer may malfunction if the controller board is not properly installed.

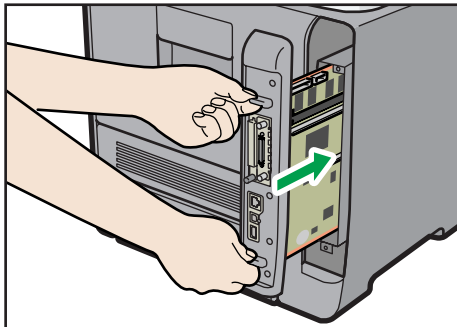

CEC076

8. Fasten the controller board to the printer with the two screws.

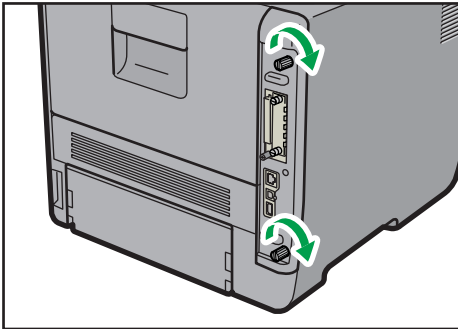

CEC072

3

Note

- After finishing the installation, you can check the SDRAM module is properly installed: Print the configuration page from the [List/Test Print] menu. If it is installed properly, the memory capacity will appear under "Total Memory" on the configuration page.
- The table below shows the total SDRAM module capacities.

| Standard | Extended | Total |
|----------|----------|--------|
| 256 MB | 256 MB | 512 MB |
| 256 MB | 512 MB | 768 MB |

- If the SDRAM module is not properly installed, repeat this procedure. If you cannot install it properly even after reinstallation, contact your sales or service representative.
- Install the controller board carefully to prevent any malfunction.
- For details on printing the configuration page, see p.44 "Test Printing".

Installing the Interface Units

Installing the Gigabit Ethernet Board

★ Important

- The printer's Ethernet and USB ports are not available when the Gigabit Ethernet board is installed in to the printer. Use the Ethernet and USB ports on the Gigabit Ethernet board.
- Before beginning work, ground yourself by touching something metal to discharge any static electricity. Static electricity can damage the Gigabit Ethernet board.
- Do not subject the Gigabit Ethernet board to physical shocks.

1. Check the contents of the package.

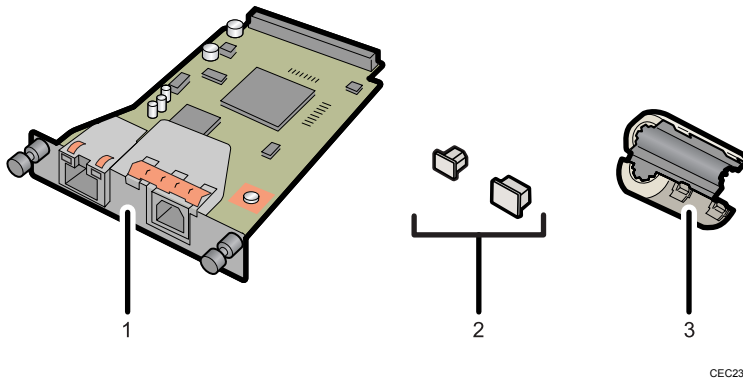

CEC233

1. Gigabit Ethernet Board
2. Protective caps (one each for the Ethernet port and the USB port)
3. Ferrite core

Design of the ferrite core varies according to printer model.

2. Turn off the power, and then unplug the power cord.

3. Disconnect the cables from the Ethernet port and the USB port of the printer, and cover each port with its protective cap.

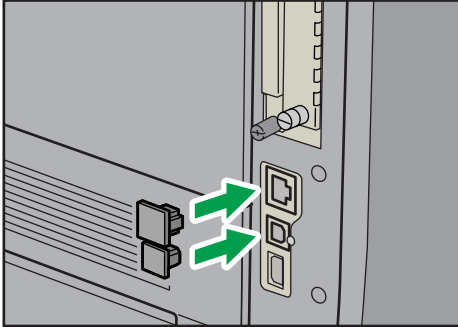

4. Remove the two screws and remove the cover of the slot in which the Gigabit Ethernet board is installed.

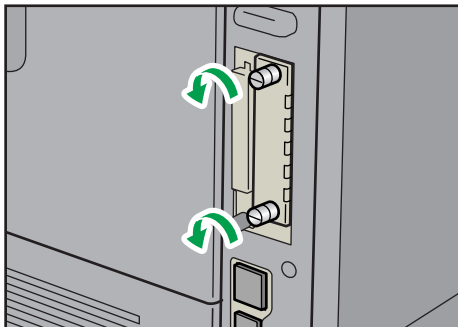

5. Fully insert the Gigabit Ethernet board.

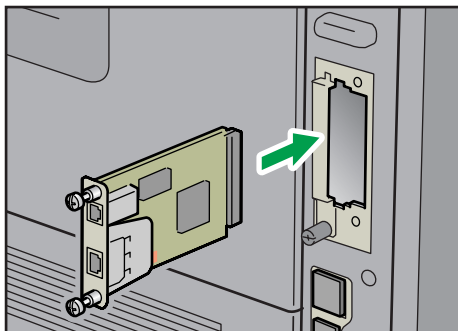

6. Tighten the two screws to secure the Gigabit Ethernet board.

Check the Gigabit Ethernet board is connected firmly to the interface board slot.

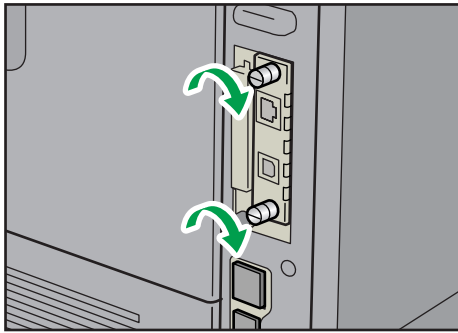

Connect the cable to the Gigabit Ethernet board. For details see p.69 "Ethernet Cable Connection" or p.72 "USB Cable Connection".

↓ Note

- Confirm that the Gigabit Ethernet board was correctly installed by printing the configuration page. If it is correctly installed, "Gigabit Ethernet" will appear for "Device Connection" on the configuration page.
- If the board was not installed properly, repeat the procedure from step 4. If it cannot be installed correctly even after reattempting installation, contact your sales or service representative.
- For details about printing the configuration page, see p.44 "Test Printing".
- Before using the Gigabit Ethernet board, you must configure settings from the printer control panel. For details, see p.75 "Ethernet Configuration".

Installing the Wireless LAN Interface Board

★ Important

- Before beginning work, ground yourself by touching something metal to discharge any static electricity. Static electricity can damage the unit.
- Do not subject the unit to physical shocks.

1. Check the contents of the package.

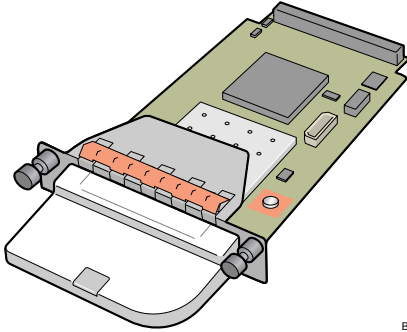

BFL301S

2. Turn off the power, and then unplug the power cord.

3. Remove the two screws and remove the cover of the slot in which the Wireless LAN interface board is installed.

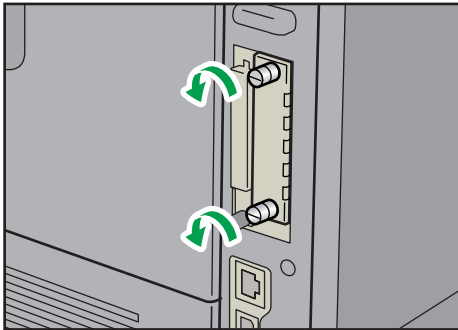

CEC061

4. Fully insert the Wireless LAN interface board.

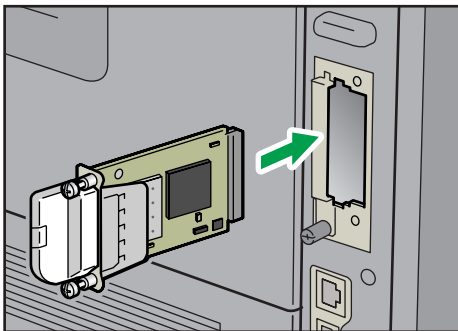

CEC065

5. Tighten the two screws to secure the interface board.

Check the Wireless LAN interface board is connected firmly to the interface board slot.

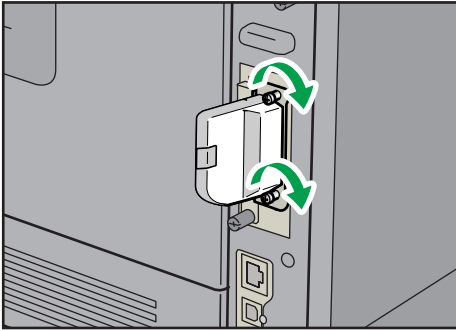

CEC242

3

↓ Note

- Confirm that the interface board was correctly installed by printing the configuration page. If it is correctly installed, "Wireless LAN" will appear for "Device Connection" on the configuration page.
- If the board was not installed properly, repeat the procedure from step 3. If it cannot be installed correctly even after reattempting installation, contact your sales or service representative.
- For details about printing the configuration page, see p.44 "Test Printing".
- Before using the Wireless LAN interface board, you must configure settings from the printer control panel. For details, see p.84 "Wireless LAN Configuration".

Installing the IEEE 1284 Interface Board

★ Important

- Before beginning work, ground yourself by touching something metal to discharge any static electricity. Static electricity can damage the IEEE 1284 interface board.
- Do not subject the IEEE 1284 interface board to physical shocks.
- For connection to the IEEE 1284 interface board, use a half pitch 36-pin interface cable.

1. Check the contents of the package.

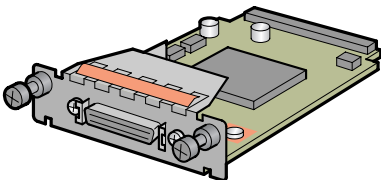

BFL302S

2. Turn off the power, and then unplug the power cord.

3. Remove the two screws and remove the cover of the slot in which the 1284 interface board is installed.

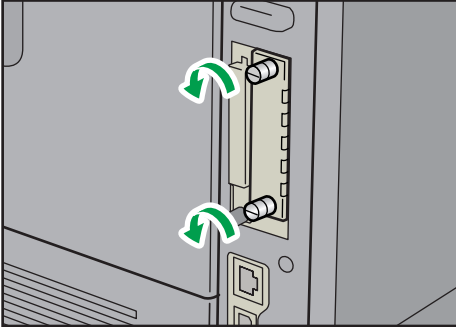

CEC061

4. Fully insert the IEEE 1284 interface board.

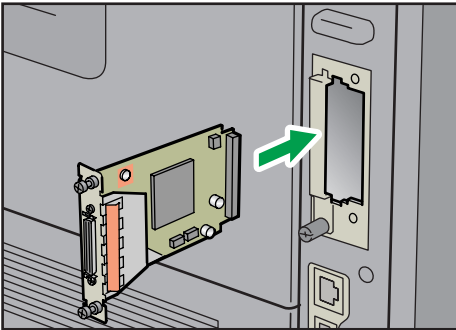

CEC066

5. Tighten the two screws to secure the interface board.

Check the IEEE 1284 interface board is connected firmly to the interface board slot.

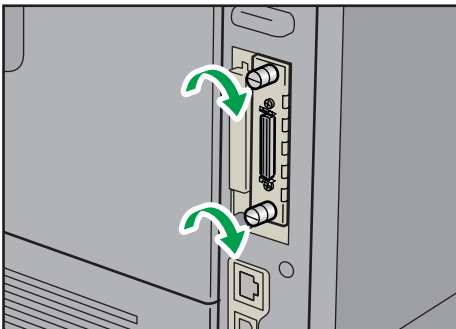

CEC060

Note

- Confirm that the IEEE 1284 interface board was correctly installed by printing the configuration page. If it is correctly installed, "Parallel Interface" will appear for "Device Connection" on the configuration page.

- If the board was not installed properly, repeat the procedure from step 3. If it cannot be installed correctly even after reattempting installation, contact your sales or service representative.
- For details about printing the configuration page, see p.44 "Test Printing".

Installing the SD Memory Card Options

⚠ CAUTION

- Keep SD memory cards out of reach of children. If a child swallows an SD memory card, consult a doctor immediately.

★ Important

- Do not subject the card to physical shocks.
- The VM card is optional to Type 1 models only. To use it, the optional 512 MB SDRAM module must be installed.
- If you are using Type 1 model, the optional SDRAM module must be installed to use the IPDS card.

1. Check the contents of the package.

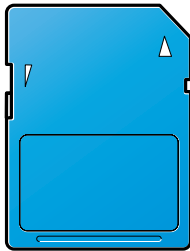

BFL308S

2. Turn off the power, and then unplug the power cord.
3. Remove the one screw, and then carefully remove the cover of the SD card slot.

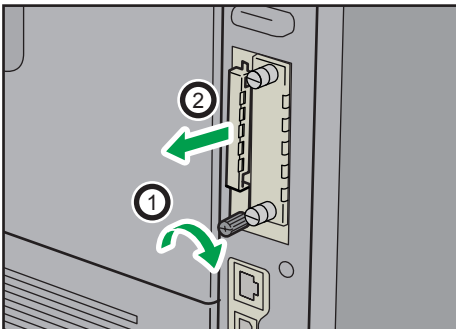

CEC068

4. Carefully push in the SD card (notched corner downward and leading), until it clicks into place.

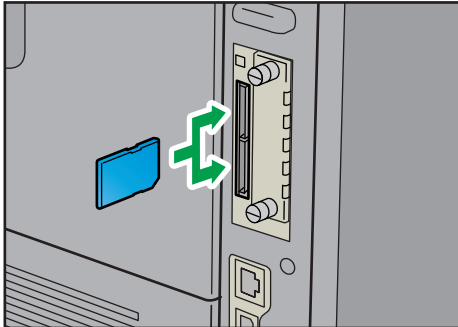

CEC070

Insert the SD card in the appropriate slot as follows:

- Upper slot: SD font card, NetWare card, IPDS card
- Lower slot: VM card, ELP-NX card

The SD card supplied with the optional hard disk (Type 1 model only) can be used in either of the two slots.

To export the printer settings by selecting [Machine Settings Export], insert the SD card on which the settings are to be stored into the lower slot.

If you want to use two or more SD cards that can be inserted in the same slot, contact your sales and service representative.

5. Reattach the cover over the SD card. Fasten the one screw to secure the cover.

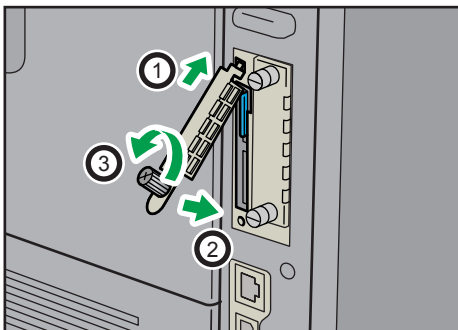

CEC069

If the ELP-NX card is inserted in the printer, the installation will automatically start when the printer is turned on. After the installation is complete, restart the printer.

Note

- Do not touch the card while the printer is in use. It may come loose, even if pushed only slightly. The slot cover must be reattached.

- You can confirm that the SD card was installed correctly by checking the control panel menu. Depending on the SD card, certain menu items appear on the display.
 - SD card supplied with the optional hard disk (Type 1 model only): Make sure [Machine Data Encryption] appears in [Security Options]. Depending on settings, [Machine Data Encryption] might not appear. For details about how to confirm this setting, consult your administrator.
 - IPDS card: Make sure [IPDS Menu] appears under [Print Settings].
 - NetWare card: Make sure [NetWare] appears in [Effective Protocol] under [Network].
 - ELP-NX card: Press the [Switch Functions] key, and then confirm that ELP-NX appears in [JavaTM/X].
- If the card is not installed properly, repeat the procedure from the beginning. If it cannot be installed correctly even after reattempting installation, contact your sales or service representative.
- For details about printing the configuration page, see p.44 "Test Printing".

4. Connecting the Printer

This chapter explains how to connect network and USB cables.

Ethernet Cable Connection

Prepare a hub and other network devices, and connect the Ethernet cable to the printer.

Connect 10BASE-T or 100BASE-TX cable to the printer's Ethernet port. For 1000BASE-T, the optional Gigabit Ethernet board is required.

CAUTION

- A network interface cable with a ferrite core must be used for RF interference suppression.

CAUTION

- For users outside the United States of America: properly shielded and grounded cables and connectors must be used for connections to a host computer (and/or peripheral) in order to meet emission limits.

CAUTION

- For users in the United States of America: properly shielded and grounded cables and connectors must be used for connections to a host computer (and/or peripheral) in order to meet FCC emission limits.

Important

- An Ethernet cable is not supplied with this printer. Select your cable according to the network environment.
- The printer's Ethernet and USB ports are not available when the Gigabit Ethernet board is attached to the printer.

Connecting to the standard Ethernet port

1. Connect the Ethernet cable to the Ethernet port.

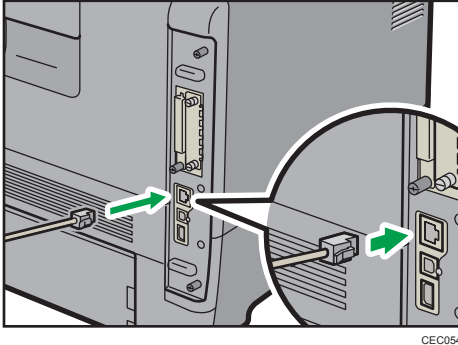

2. Connect the other end of the cable to the network, for example using a hub.

Connecting to the Ethernet port of the Gigabit Ethernet board

1. Attach the ferrite core to the Ethernet cable.

Attach the other ferrite core about 10 cm (4 inches) (1) from this core making a loop as shown.

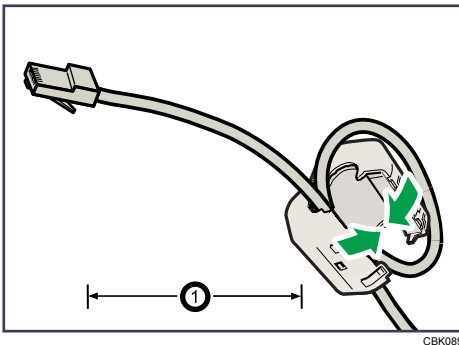

2. Connect the Ethernet cable to the Ethernet port of the Gigabit Ethernet board.

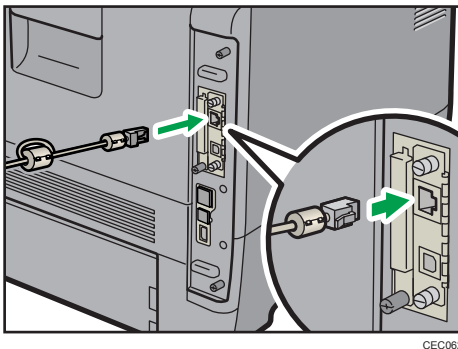

3. Connect the other end of the cable to the network, for example using a hub.

↓ Note

- For details about configuring the network environment, see p.75 "Ethernet Configuration".
- For details about installing the Gigabit Ethernet board, see p.59 "Installing the Interface Units".

Reading the LED Lamps

Standard Ethernet port

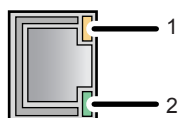

CBK090

1. Yellow indicator

If the printer is connected to a 100BASE-TX Ethernet, the yellow indicator will be lit. This indicator will be unlit if the printer is connected to a 10BASE-T Ethernet.

2. Green indicator

If the printer is connected to a 10BASE-T Ethernet or 100BASE-TX Ethernet, the green indicator will be lit.

Optional Gigabit Ethernet board

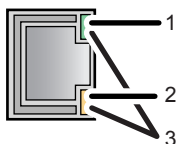

CBK091

1. Green indicator

If the printer is connected to a 10BASE-T Ethernet, the green indicator will be lit. This indicator will be unlit if the printer is connected to a 100BASE-TX Ethernet.

2. Yellow indicator

If the printer is connected to a 100BASE-TX Ethernet, the yellow indicator will be lit. This indicator will be unlit if the printer is connected to a 10BASE-T Ethernet.

3. Green and yellow indicators

If the printer is connected to a 1000BASE-T Ethernet, both indicators will be lit.

USB Cable Connection

⚠ CAUTION

- For users outside the United States of America: properly shielded and grounded cables and connectors must be used for connections to a host computer (and/or peripheral) in order to meet emission limits.

⚠ CAUTION

- For users in the United States of America: properly shielded and grounded cables and connectors must be used for connections to a host computer (and/or peripheral) in order to meet FCC emission limits.

4

★ Important

- USB connection is possible under Windows XP/Vista/7, Windows Server 2003/2003 R2/2008/2008 R2, and Mac OS X 10.3.3 or later.
- A USB cable is not supplied with this printer. Select your cable according to the computer.

1. Connect the USB cable to the printer.

- **Connecting the USB cable to the standard USB port B**

Connect the smaller connector of the USB cable to the standard USB port B on the left side of the printer.

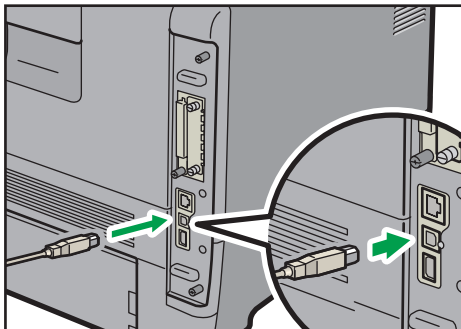

- **Connecting the USB cable to the Gigabit Ethernet board USB port**

Connect the smaller connector of the USB cable to the USB port of the Gigabit Ethernet board.

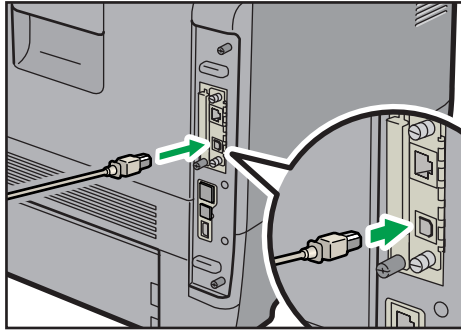

CEC063

- 2. Connect the opposite end's flat connector to the desired device such as your computer's USB interface, or a USB hub.**

The printer is now connected to the computer. The Plug and Play screen appears on the computer display. For details, see "Installing the Printer Driver Using USB", Driver Installation Guide.

Parallel Cable Connection

The type of cable required varies depending on the computer you are using. Make sure to use the interface cable compliant with your computer.

⚠ CAUTION

- For users outside the United States of America: properly shielded and grounded cables and connectors must be used for connections to a host computer (and/or peripheral) in order to meet emission limits.

⚠ CAUTION

- For users in the United States of America: properly shielded and grounded cables and connectors must be used for connections to a host computer (and/or peripheral) in order to meet FCC emission limits.

4

★ Important

- The printer's parallel connection is a standard bidirectional interface that requires an IEEE 1284-compliant half pitch 36-pin parallel cable and host computer parallel port.
- Use shielded interface cable. Unshielded cables create electromagnetic interference.

1. Turn off the printer and computer.
2. Connect the interface cable to the IEEE 1284 interface board.

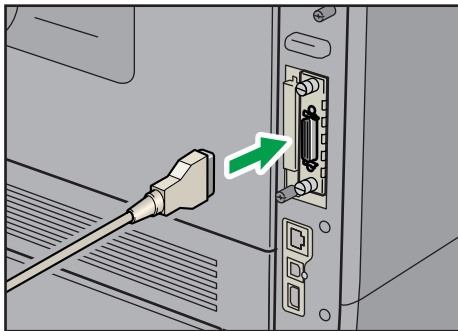

3. Connect the other end of the interface cable to your computer, and then secure the cable.

The printer is now connected to the computer. Install the printer driver. For details, see "Installing the Printer Driver Using Parallel Cable", Driver Installation Guide.

↓ Note

- For details about installing the 1284 interface board, see p.59 "Installing the Interface Units".

5. Configuration

This chapter explains supported network connections, and settings for the IP addresses and the Wireless LAN security.

Ethernet Configuration

★ Important

- Configure the printer for the network using the control panel.
- The following table shows the control panel settings and their default values. These items appear in the [Network] under [Host Interface] menu.

| Setting Name | Default |
|----------------------------|--|
| Machine IPv4 Address | <ul style="list-style-type: none">• Auto-Obtain (DHCP): On• IPv4 Address: 11.22.33.44• Subnet Mask: 0.0.0.0• Gateway Address: 0.0.0.0 |
| IPv6 Stateless Setting | Active |
| IPsec | Inactive |
| NW Frame Type | Auto Select |
| Effective Protocol | <ul style="list-style-type: none">• IPv4: Active• IPv6: Inactive• NetWare: Inactive• SMB: Active• AppleTalk: Inactive |
| Ethernet Speed | Auto Select |
| IEEE802.1X Auth.(Ethernet) | Inactive |
| Restr.IEEE802.1X Auth.Def. | - |
| LAN Type | Ethernet |
| Permit SSL/TLS Comm. | Ciphertext Priority |

↓ Note

- If DHCP is in use on your network, the IP address, subnet mask, and gateway address are all set automatically.
- If the printer is already placed on a TCP/IP-capable environment, you can also use a Web browser to configure the IP address-related settings.
- Configure these setting as necessary. See Software Guide for details.

Specifying an IP Address (No DHCP)

Follow this procedure to assign a specific IP address to the printer. This is only necessary when you will use the printer on a network without DHCP, or want to prevent the printer's IP address from changing.

Before beginning, make sure that you know the IP address, subnet mask and gateway address that the printer will use.

5

1. Press the [Menu] key.

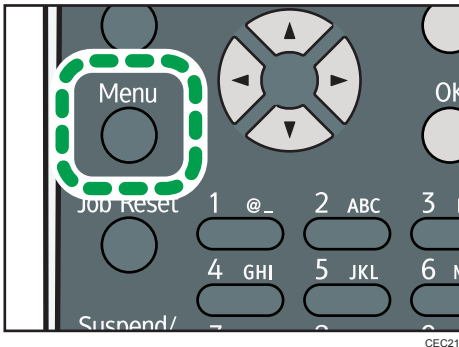

2. Press the [▼] or [▲] key to select [Host Interface], and then press the [OK] key.

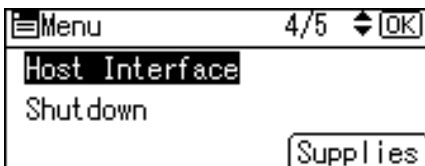

3. Press the [▼] or [▲] key to select [Network], and then press the [OK] key.

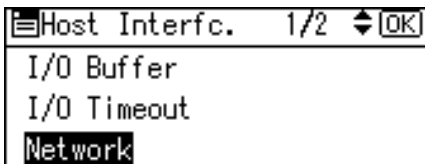

4. Press the [▼] or [▲] key to select [Effective Protocol], and then press the [OK] key.

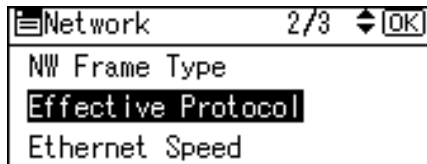

5. Press the [▼] or [▲] key to select the appropriate network protocol, and then press the [OK] key.

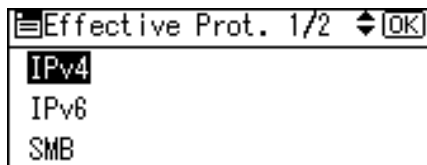

6. Press the [▼] or [▲] key to select [Active] or [Inactive], and then press the [OK] key.

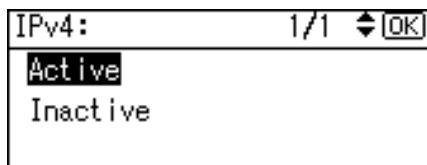

Set other protocols you need to set in the same way.

- Select [Inactive] for unused protocols.
- Enable IPv4 to use the pure IPv4 environment of NetWare5/5.1, NetWare 6/6.5.

7. Press the [Escape] key until the screen returns to the [Network] menu.
8. If you use IPv4, assign the IPv4 address to the printer. Press the [▼] or [▲] key to select [Machine IPv4 Address], and then press the [OK] key.

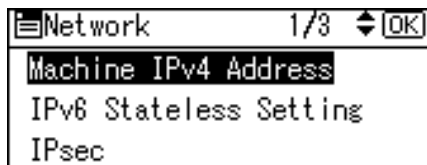

To get the IP address for the printer, consult your network administrator.

9. To specify the IP Address, press [IP Add.].

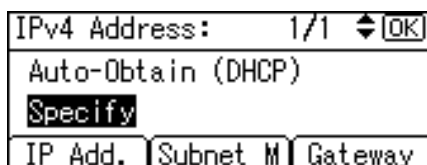

If you use IPv4, also assign the subnet mask and gateway address. To assign these, press [Subnet M] or [Gateway].

10. Enter the address, and then press the [OK] key.

Change the IP address from "11.22.33.44" to an IP address supported by your network.

| | | |
|---------------------------|-----|-------|
| IPv4 Address: | ↕ | [OK] |
| Enter with No. keys or ↕. | | |
| 192 | 168 | 0 206 |

11. Use the same method to assign the subnet mask and gateway address.**12. Press the [▼] or [▲] key to select [Specify], and then press the [OK] key.**

| | | | |
|--------------------|----------|---------|------|
| IPv4 Address: | 1/1 | ↕ | [OK] |
| Auto-Obtain (DHCP) | | | |
| Specify | | | |
| IP Add. | Subnet M | Gateway | |

13. Press the [Menu] key to return to the initial screen.**14. Print a configuration page to confirm the settings.****Note**

- For details about printing the configuration page, see p.44 "Test Printing".

Receiving an IP Address Automatically (DHCP)

Follow this procedure to set the printer to receive an IP address automatically using DHCP. The DHCP feature is active by default, so this procedure is only required if you have changed the default settings.

★ Important

- When [Auto-Obtain (DHCP)] is selected, you cannot configure the IP address, subnet mask, or gateway address.
- Consult your network administrator for information about configuring network settings.

1. Press the [Menu] key.

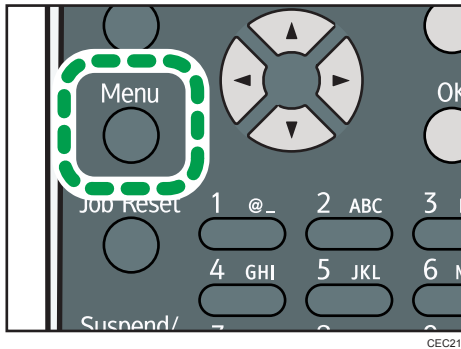

2. Press the [▼] or [▲] key to select [Host Interface], and then press the [OK] key.

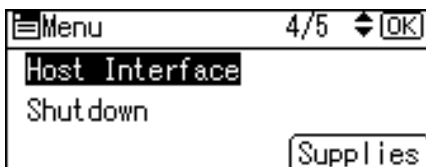

3. Press the [▼] or [▲] key to select [Network], and then press the [OK] key.

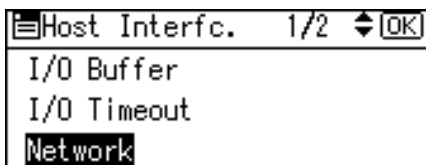

4. Press the [▼] or [▲] key to select [Machine IPv4 Address], and then press the [OK] key.

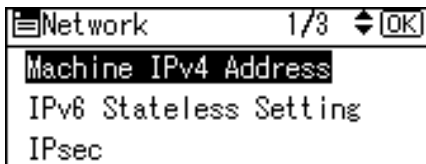

5. Press the [▼] or [▲] key to select [Auto-Obtain (DHCP)], and then press the [OK] key.

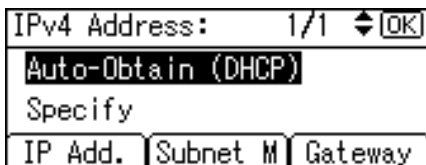

To check the detected addresses, press the followings:

- [IP Add.]: IP address
- [Subnet M]: Subnet Mask
- [Gateway]: Default Gateway

6. Press the [Menu] key to return to the initial screen.
7. Print a configuration page to confirm the settings.

Note

- For details about printing the configuration page, see p.44 "Test Printing".

Configuring Network Settings When Using NetWare

To use NetWare, select the appropriate NetWare frame type from the following.

- Auto Select
- Ethernet II
- Ethernet 802.2
- Ethernet 802.3
- Ethernet SNAP

Important

- Usually, you can use the default (Auto Select). When you first select [Auto Select], the frame type detected by the printer is adopted. However, if your network can use more than two frame types, the printer may fail to select the correct frame type with [Auto Select] selected. In this case, select the preferred frame type.

1. Press the [Menu] key.

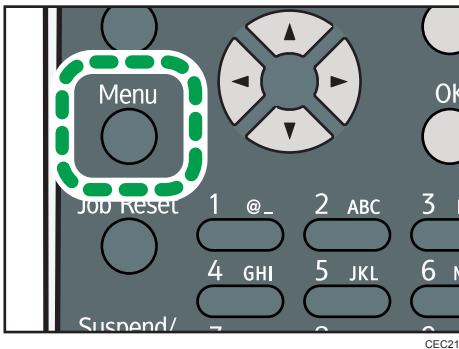

2. Press the [▼] or [▲] key to select [Host Interface], and then press the [OK] key.

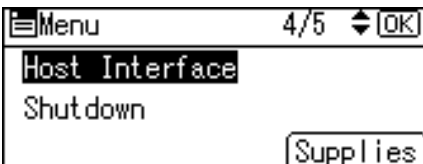

3. Press the [▼] or [▲] key to select [Network], and then press the [OK] key.

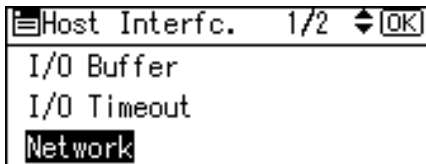

4. Press the [▼] or [▲] key to select [NW Frame Type], and then press the [OK] key.

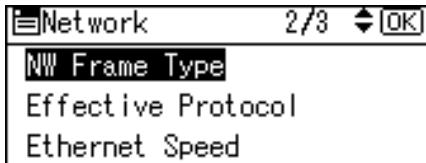

5. Press the [▼] or [▲] key to select the frame type to use, and then press the [OK] key.

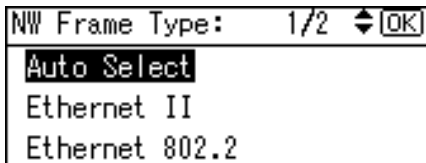

6. Press the [Menu] key to return to the initial screen.
7. Print a configuration page to confirm the settings.

Note

- For details about printing the configuration page, see p.44 "Test Printing".

Setting the Ethernet Speed

You can set the speed that the printer will use for Ethernet communications. In most cases, this should be left on the default setting, [Auto Select]. This setting allows two interfaces to automatically determine the optimum speed when they are connected.

| Router/HUB | Printer | | | | |
|---------------------|----------------------|----------------------|-----------------------|-----------------------|---------------|
| | [10Mbps Half Duplex] | [10Mbps Full Duplex] | [100Mbps Half Duplex] | [100Mbps Full Duplex] | [Auto Select] |
| 10 Mbps half duplex | ○ | - | - | - | ○ |
| 10 Mbps full duplex | - | ○ | - | - | - |

| Router/HUB | Printer | | | | |
|-----------------------------------|-----------------------|----------------------|-----------------------|-----------------------|-----------------------|
| | [10Mbps Half Duplex] | [10Mbps Full Duplex] | [100Mbps Half Duplex] | [100Mbps Full Duplex] | [Auto Select] |
| 100 Mbps half duplex | - | - | <input type="radio"/> | - | <input type="radio"/> |
| 100 Mbps full duplex | - | - | - | <input type="radio"/> | - |
| auto-negotiation (auto selection) | <input type="radio"/> | - | <input type="radio"/> | - | <input type="radio"/> |

5

★ Important

- Connection cannot be established if the selected Ethernet speed does not match your network's transmission speed.
- The use of this feature is recommended. To use it, select [Auto Select].

1. Press the [Menu] key.

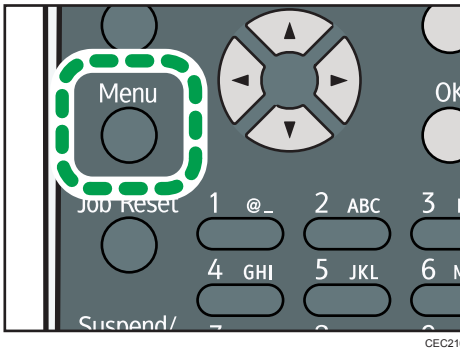

2. Press the [▼] or [▲] key to select [Host Interface], and then press the [OK] key.



3. Press the [▼] or [▲] key to select [Network], and then press the [OK] key.

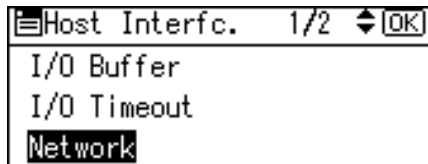

4. Press the [▼] or [▲] key to select [Ethernet Speed], and then press the [OK] key.

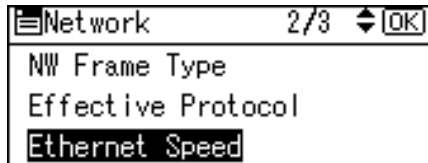

5. Press the [▼] or [▲] key to select the Ethernet speed, and then press the [OK] key.

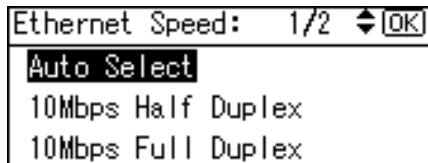

6. Press the [Menu] key to return to the initial screen.
7. Print a configuration page to confirm the settings.

Note

- For details about printing the configuration page, see p.44 "Test Printing".

Wireless LAN Configuration

★ Important

- Ethernet and Wireless LAN cannot be used at the same time.
- To use Wireless LAN, set as follows using the control panel: press the [Menu] key, select [Host Interface], [Network], [LAN Type], and then select [Wireless LAN]. In addition, you must set the IP address, subnet mask, gateway address, DHCP, Frame Type (NW), and active protocol as explained in p.75 "Ethernet Configuration".
- The following table shows the control panel settings and their defaults. These items appear in the [Wireless LAN] under [Host Interface] menu.

| Setting Name | Default |
|---------------------|---------------------|
| Communication Mode | Infrastructure Mode |
| SSID Setting | blank |
| Ad-hoc Channel | 11 |
| Security Method | Off |
| Wireless LAN Signal | - |
| Restore Defaults | - |

5

1. Press the [Menu] key.

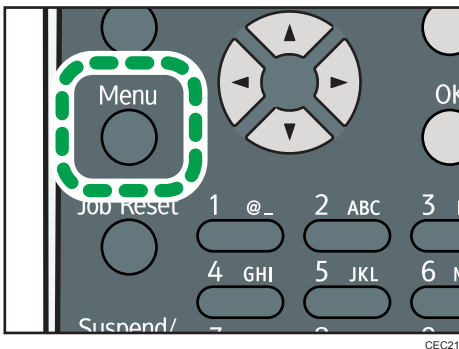

CEC216

2. Press the [▼] or [▲] key to select [Host Interface], and then press the [OK] key.

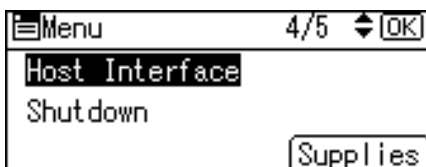

3. Press the [▼] or [▲] key to select [Wireless LAN], and then press the [OK] key.

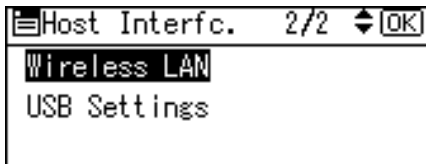

4. Press the [▼] or [▲] key to select [Communication Mode], and then press the [OK] key.

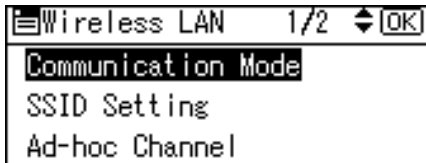

5. Press the [▼] or [▲] key to select the transmission mode of Wireless LAN, and then press the [OK] key.

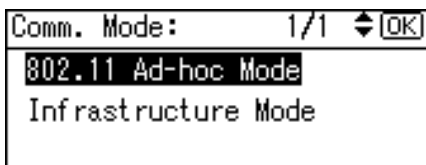

The transmission mode of the Wireless LAN can also be set using Web Image Monitor.

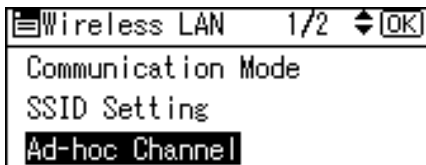

6. If [802.11 Ad-hoc Mode] is selected for [Communication Mode], confirm the channel to use for transmission.
7. Press the [▼] or [▲] key to select [Ad-hoc Channel], and then press the [OK] key.

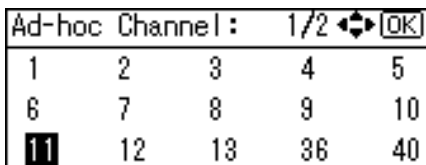

8. Press the scroll keys to select the Ad-hoc channel, and then press the [OK] key.



Select an Ad-hoc channel according to the IEEE 802.11 standard you are using.

- When using IEEE 802.11 b/g:
 -  **Region A** (mainly Europe and Asia)
Channels 1 to 13
 -  **Region B** (mainly North America)

Channels 1 to 11

- When using IEEE 802.11 a:
Channels 36,40,44,48

9. Press the [Menu] key to return to the initial screen.

10. Print a configuration page to confirm the settings.

↓ Note

- For details, see Web Image Monitor Help, and "Using Web Image Monitor", Software Guide.
- For details about printing the configuration page, see p.44 "Test Printing".

Setting the SSID

5

When [Communication Mode] is set to [Infrastructure Mode] or [802.11 Ad-hoc Mode], you must specify the Service Set Identifier (SSID) of the wireless access point that the printer will connect to for network access.

Ask your network administrator for the SSID to use.

1. In the [Wireless LAN] menu, press the [▼] or [▲] key to select [SSID Setting], and then press the [OK] key.

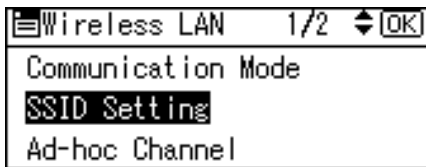

If an SSID has been set, you can check the current SSID setting.

2. Press [SSID], and then press [Enter].

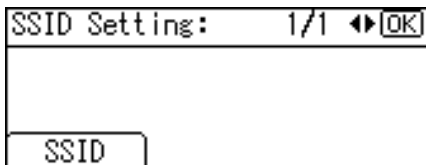

3. Enter the characters, and then press the [OK] key.

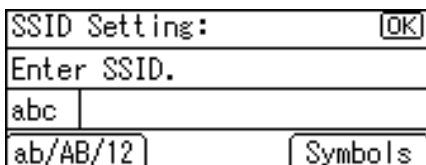

You can switch among lower /upper cases and numeric characters by pressing [ab/AB/12].

The characters that can be used are ASCII 0 × 20-0 × 7e (32 bytes).

4. Press the [Menu] key to return to the initial screen.

5. Print a configuration page to confirm the settings.

Note

- The SSID can also be set using a Web browser. For details, see Web Image Monitor Help.
- For details about printing the configuration page, see p.44 "Test Printing".

Confirming Wireless Network Connectivity

After you have installed the Wireless LAN interface unit, use the following procedure to check for Wireless LAN connectivity.

Make sure the LED on the Wireless LAN interface unit is lit.

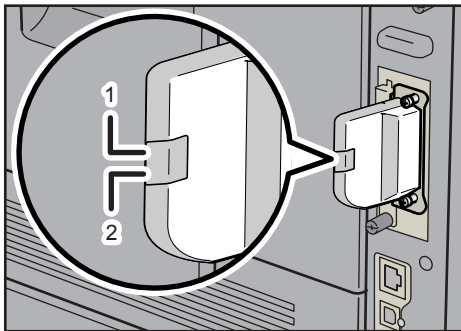

CEC077

1. If the Wireless LAN unit is receiving power, the upper indicator will be lit green.
2. If the printer is connected to an operational network and is communicating normally, the lower indicator will be lit orange.

Cautions When Using a Wireless LAN

A Wireless LAN uses radio waves instead of cables to send and receive data. Because radio waves usually pass through walls and other obstructions, the following problems may arise if you do not configure wireless security settings.

Information leakage

Information such as IDs, passwords, credit card numbers, and e-mail content may be seen by an unauthorized 3rd party.

Unauthorized network access

- Damage to or alteration of data and/or system configurations by viruses or other malware.
- Impersonation of legitimate network users, resulting in data theft.
- Theft of sensitive or confidential data.

To minimize the possibility of these threats, it is recommended that you check the available features of this printer, wireless access points, and other equipment that uses the Wireless LAN, and configure security settings for the Wireless LAN.

Setting Security Method of Wireless LAN

Setting a WEP Key

If the wireless network uses WEP to encrypt transmitted data, the corresponding WEP key must be set to the printer to allow communications with other network devices.

Ask your network administrator for the WEP key to use.

1. Press the [Menu] key.

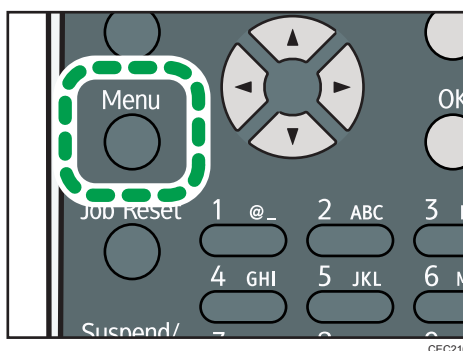

2. Press the [▼] or [▲] key to select [Host Interface], and then press the [OK] key.

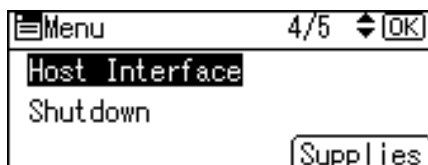

3. Press the [▼] or [▲] key to select [Wireless LAN], and then press the [OK] key.

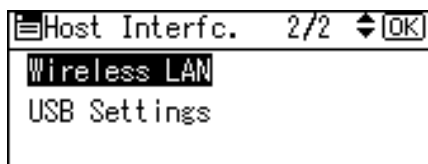

4. Press the [▼] or [▲] key to select [Security Method], and then press the [OK] key.

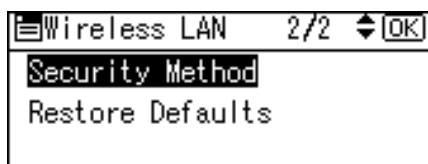

5. Press the [▼] or [▲] key to select [WEP], and then press [Details].

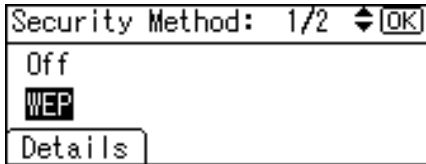

When activating the WEP setting, you will need to enter the WEP key.

6. Enter the characters, and then press the [OK] key.

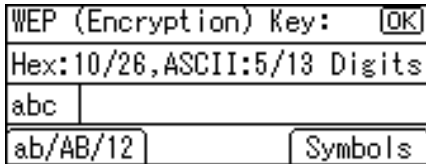

5

- When entering a character, pressing the [OK] key will mask it with an asterisk for security reasons.
- When using 64-bit WEP, up to 10 hexadecimal characters or five ASCII characters can be entered. When using 128-bit WEP, up to 26 hexadecimal characters or 13 ASCII characters can be used.
- Up to 10 or 26 hexadecimal characters and 5 or 13 ASCII characters can be entered.
- For ASCII character strings, uppercase and lowercase letters are differentiated, so be sure to enter characters in the required case.

7. Press the [▼] or [▲] key to select [WEP], and then press the [OK] key.

8. Press the [Menu] key to return to the initial screen.

9. Print a configuration page to confirm the settings.

↓ Note

- The WEP key can also be set using a Web browser. For details, see Web Image Monitor Help.
- For details about printing the configuration page, see p.44 "Test Printing".

Setting WPA

In the case of using WPA on a network, activate the WPA setting to be used for communication along with WPA. Consult your network administrator for information about making authentication settings.

★ Important

- For setting WPA, installing the optional Hard disk is required.

1. Press the [Menu] key.

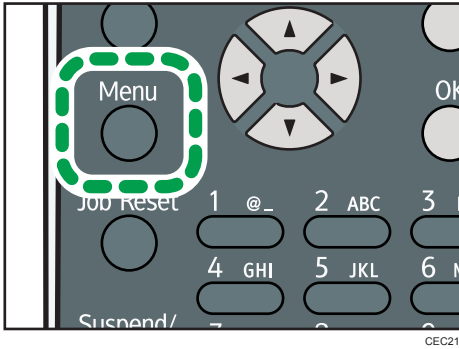

2. Press the [▼] or [▲] key to select [Host Interface], and then press the [OK] key.



3. Press the [▼] or [▲] key to select [Wireless LAN], and then press the [OK] key.

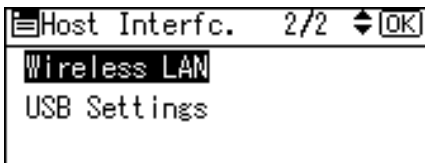

4. Press the [▼] or [▲] key to select [Security Method], and then press the [OK] key.

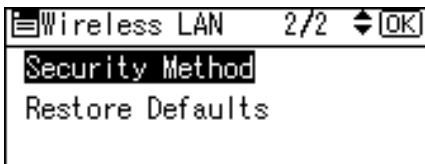

5. Press the [▼] or [▲] key to select [WPA], and then press [Details].

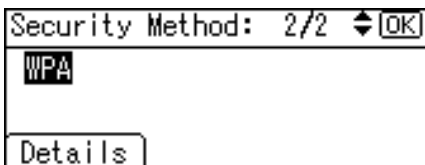

6. Press the [▼] or [▲] key to select [Encryption Method], and then press the [OK] key.

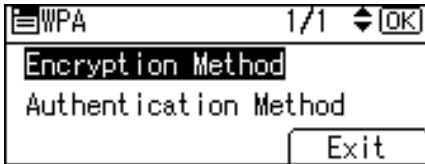

7. Press the [▼] or [▲] key to select encryption method, and then press the [OK] key.

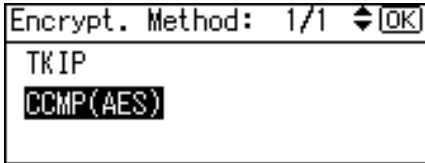

Consult your network administrator for information about making encryption settings.

Encryption settings are as follows:

- [TKIP]
 - Uses the same algorithm as RC4, but further reduces vulnerability using methods such as key mixing.
- [CCMP(AES)]
 - Increases security using AES (Advanced Encryption Standard).

The display returns to the [WPA] menu.

8. Press the [▼] or [▲] key to select [Authentication Method], and then press the [OK] key.

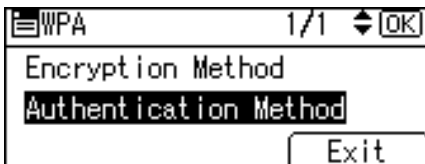

9. Press the [▼] or [▲] key to select authentication settings, and then press the [OK] key.

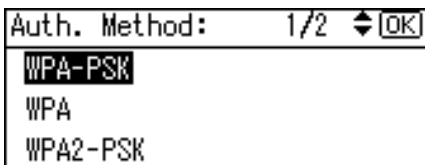

Authentication settings are as follows:

- [WPA-PSK]
 - Performs authentication using an encryption key (a Pre-Shared Key) that is shared by the access point and client.
- [WPA]

WPA uses CA certificates and a RADIUS server to provide secure wireless communication.

- [WPA2-PSK]

As with WPA-PSK, authenticate using the encryption key (a Pre-Shared Key) shared by the access point and client. Enter Pre-Shared Key using between 8 and 63 ASCII characters.

- [WPA2]

WPA2 is an expanded version of WPA that fully supports IEEE 802.11i.

Wait for two seconds, the display returns to the [WPA] menu.

10. If [WPA] or [WPA2] is selected in step 9, a confirmation message appears. Press [OK].

Wait for two seconds. The display returns to the [WPA] menu, proceed to step 15.

11. If [WPA-PSK] or [WPA2-PSK] is selected in step 9, enter the Pre-Shared Key, and then press the [OK] key.

- When entering a character, pressing the [OK] key will mask it with an asterisk for security reasons.
- Enter the Pre-Shared Key using between 8 and 63 ASCII characters.
- Uppercase and lowercase letters are differentiated, so be sure to enter characters in the required case.
- Wait for two seconds. The display returns to the [Authentication Method] menu.

12. Press the [Escape] key.

13. Press [Exit].

14. Press the [▼] or [▲] key to select [WPA], and then press the [OK] key.

15. Press the [Menu] key to return to the initial screen.

16. Print a configuration page to confirm the settings.

Note

- For details about printing the configuration page, see p.44 "Test Printing".

Configuring IEEE 802.1X

IEEE 802.1X can be configured using Web Image Monitor's administrator mode. You can select four types of EAP authentication method: EAP-TLS, LEAP, EAP-TTLS and PEAP. Note that each EAP authentication method has different configuration settings and authentication procedures.

Types and requirements of certificates are as follows:

EAP Types Requiring a "Site Certificate"

EAP-TLS, EAP-TTLS, PEAP (Necessary except LEAP)

EAP Types Requiring a "Site Certificate" and a "Device Certificate"

EAP-TLS, PEAP (Phase 2 is for TLS only)

If a certificate is required, configure all settings after installing the certificate.

5

Installing a Site Certificate

Access the authentication server and obtain the CA certificate.

Methods of obtaining certificates differ according to the operating system you are using.

1. Log in to Web Image Monitor as an administrator.
2. In the menu area, click [Configuration].
3. Under "Security", click [Site Certificate].
4. Click [Browse] on the "Site Certificate to Import" window, and then select the CA certificate you obtained.
5. Click [Import].
6. Check that the imported certificate's [Status] shows "Trustworthy".
If [Site Certificate Check] shows [Active], and the [Status] of the certificate shows [Untrustworthy], communication might not be possible.
7. Click [OK].
8. Click [Logout].
9. Quit the Web Image Monitor.

Installing Device Certificate

1. Log in to Web Image Monitor as an administrator.
2. In the menu area, click [Configuration].
3. Under "Security", click [Device Certificate].
4. Click [Certificate 2] on the "Device Certificate" window, and then click [Request].

5. Enter appropriate "Common Name" and "Country Code" on "Certificate Information" page, and then click [OK].
6. "Updating..." appears. Wait for about 2 minutes, and then click [OK].
7. Click [Details], shown in the "Device Certificate" window as the memo pad icon for "Requesting".
8. Select all, and then copy the entire "Text for Requested Certificate" text that is displayed in the "Certificate Status" window.
9. Access the certificate authority server, and then obtain the CA signified certificate using the text copied into "Text for Requested Certificate" windows.
Obtaining the certificate differs depending on the environment you want to use.
10. Click [Certificate 2] on "Device Certificate" window, and then click [Install].
11. Using a text editor, open the CA signified certificate downloaded in step 9, and then copy over all the text.
12. In the [Enter Certificate Request] window, paste all the text copied into the CA signified certificate.
13. Click [OK].
14. "Updating..." appears. Wait for about one or two minutes, and then click [OK].
15. Check that the "Device Certificate" shows "Installed".
16. Click [Certificate 2] on "Certification", and then click [OK].
17. Click [Logout].
18. Quit Web Image Monitor.

↓ Note

- If you request two certificates simultaneously, the certificate authority might not display either certificate. Click [Cancel Request] to cancel the request.
- You can select [Certificate 1-4] in the "Device Certificate" window. Note that if you select [Certificate 1] in the "Device Certificate" window, you must select "Certificate 1" in the "IEEE 802.1X" drop down menu in the "Certification" window.
- Click [Cancel Request] to cancel the request for the server certificate.
- If "Not found" appears after clicking [OK] in steps 6 and 14, wait one or two minutes, and then click [Refresh].

Setting Items of IEEE 802.1X for Ethernet

1. Log in to Web Image Monitor as an administrator.
2. In the menu area, click [Configuration].
3. Under "Security", click [IEEE 802.1X].

4. In "User Name", enter the user name set in the RADIUS server.

5. Enter the domain name in "Domain Name".

6. Select "EAP Type". Configurations differ according to the EAP Type.

EAP-TLS

- Make the following settings according to the operating system you are using:
 - Select [On] or [Off] in "Authenticate Server Certificate".
 - Select [On] or [Off] in "Trust Intermediate Certificate Authority".
 - Enter the host name of the RADIUS server on "Server ID".
 - Select [On] or [Off] in "Permit Sub-domain".

LEAP

- Click [Change] in "Password", and then enter the password set in the RADIUS server.

EAP-TTLS

- Click [Change] in "Password", and then enter the password set in the RADIUS server.
- Click [Change] in "Phase 2 User Name", and then enter the user name set in the RADIUS server.
- Select [CHAP], [MSCHAP], [MSCHAPv2], [PAP], or [MD5] in "Phase 2 Method".

Certain methods might not be available, depending on the RADIUS server you want to use.

- Make the following settings according to the operating system you are using:
 - Select [On] or [Off] in "Authenticate Server Certificate".
 - Select [On] or [Off] in "Trust Intermediate Certificate Authority".
 - Enter the host name of the RADIUS server in "Server ID".
 - Select [On] or [Off] in "Permit Sub-domain".

PEAP

- Click [Change] in "Password", and then enter the password set in the RADIUS server.
If [TLS] is selected for "Phase 2 Method", you do not need to specify a password.
- Click [Change] on "Phase 2 User Name", and then enter the user name set in the RADIUS server.
- Select [MSCHAPv2] or [TLS] in "Phase 2 Method".

When you select [TLS], you must install "IEEE 802.1X Client Certificate".

- Make the following settings according to the operating system you are using:
 - Select [On] or [Off] in "Authenticate Server Certificate".
 - Select [On] or [Off] in "Trust Intermediate Certificate Authority".
 - Enter the host name of the RADIUS server on "Server ID".
 - Select [On] or [Off] in "Permit Sub-domain".

7. Click [OK].

8. "Updating..." appears. Wait for about one or two minutes, and then click [OK].
9. Under "Interface", click [Interface Settings].
10. Select [Active] in "Ethernet Security".
11. Click [OK].
12. "Updating..." appears. Wait for about one or two minutes, and then click [OK].
13. Click [Logout].
14. Quit the Web Image Monitor.

↓ Note

- If there is a problem with settings, you might not be able to communicate with the printer. To identify the problem, print a network summary.
- If you cannot identify the problem, reset the printer interface to normal, and then repeat the procedure from the beginning.

Setting Items of IEEE 802.1X for Wireless LAN

1. Log in to Web Image Monitor as an administrator.
2. In the menu area, click [Configuration].
3. Under "Security", click [IEEE 802.1X].
4. In "User Name", enter the user name set in the RADIUS server.
5. Enter the domain name in "Domain Name".
6. Select "EAP Type". Configurations differ according to the EAP Type.

EAP-TLS

- Make the following settings according to the operating system you are using:
 - Select [On] or [Off] in "Authenticate Server Certificate".
 - Select [On] or [Off] in "Trust Intermediate Certificate Authority".
 - Enter the host name of the RADIUS server on "Server ID".
 - Select [On] or [Off] in "Permit Sub-domain".

LEAP

- Click Change in "Password", and then enter the password set in the RADIUS server.

EAP-TTLS

- Click [Change] in "Password", and then enter the password set in the RADIUS server.
- Click [Change] in "Phase 2 User Name", and then enter the user name set in the RADIUS server.
- Select [CHAP], [MSCHAP], [MSCHAPv2], [PAP], or [MD5] in "Phase 2 Method".

Certain methods might not be available, depending on the RADIUS server you want to use.

- Make the following settings according to the operating system you are using:
 - Select [On] or [Off] in "Authenticate Server Certificate".
 - Select [On] or [Off] in "Trust Intermediate Certificate Authority".
 - Enter the host name of the RADIUS server in "Server ID".
 - Select [On] or [Off] in "Permit Sub-domain".

PEAP

- Click [Change] in "Password", and then enter the password set in the RADIUS server.
If [TLS] is selected for "Phase 2 Method", you do not need to specify a password.
- Click [Change] on "Phase 2 User Name", and then enter the user name set in the RADIUS server.
- Select [MSCHAPv2] or [TLS] in "Phase 2 Method".
When you select [TLS], you must install "IEEE 802.1X Client Certificate".
- Make the following settings according to the operating system you are using:
 - Select [On] or [Off] in "Authenticate Server Certificate".
 - Select [On] or [Off] in "Trust Intermediate Certificate Authority".
 - Enter the host name of the RADIUS server on "Server ID".
 - Select [On] or [Off] in "Permit Sub-domain".

5

7. Click [OK].
8. "Updating..." appears. Wait for about one or two minutes, and then click [OK].
9. Under "Interface", click [Wireless LAN Settings].
10. Select [Wireless LAN] in "LAN Type".
11. Select [Infrastructure Mode] in "Communication Mode".
12. Enter the alphanumeric characters (a-z, A-Z, or 0-9) in [SSID] according to the access point you want to use.
13. Select [WPA] in "Security Method".
14. Select [TKIP] or [CCMP (AES)] in "WPA Encryption Method" according to the access point you want to use.
15. Select [WPA] or [WPA2] in "WPA Authentication Method".
16. Click [OK].
17. "Updating..." appears. Wait for about one or two minutes, and then click [OK].
18. Click [Logout].
19. Quit the Web Image Monitor.

↓ Note

- If there is a problem with settings, you might not be able to communicate with the printer. To identify the problem, print a network summary.

- If you cannot identify the problem, reset the printer interface to normal, and then repeat the procedure from the beginning.



6. Loading Paper

This chapter explains the paper sizes and types supported by this printer, and how to load paper into the paper trays.



Supported Paper for Each Tray

The tables in this section provide details of the sizes, types, feed directions, and maximum number of sheets of paper that can be loaded in each of the printer's trays.

Symbols

| | In this manual | On the display |
|---------------------------|--|-------------------------|
| Short-edge feed direction |  (Feed direction) | A4 8 1/2 " × 11 " |
| Long-edge feed direction |  (Feed direction) | A5 8 1/2 " × 5 1/2 " |





Standard Paper Feed Tray

| | |
|------------------------------------|--|
| Paper types | Plain Paper, Middle Thick, Thick Paper 1, Thick Paper 2, Thick Paper 3, Thin Paper, Letterhead, Label Paper, Special Paper 1, Special Paper 2, Special Paper 3, Preprinted Paper, Color Paper, Recycled Paper |
| Automatically selected paper sizes | <p>The following paper sizes are supported by this printer's automatic paper size detection function:</p> <p> Region A A4, A5, B5, 8 1/2 " × 14 " (Legal), 8 1/2 " × 11 " (Letter)</p> <p> Region B A4, B5, 8 1/2 " × 14 " (Legal), 8 1/2 " × 11 " (Letter), 5 1/2 " × 8 1/2 " (Half Letter)</p> <p>For details about paper size settings, see p.121 "Specifying paper size automatically for a standard or optional paper feed tray".</p> |

| | |
|--|--|
| <p>Paper sizes requiring manual settings</p> | <p>The following sizes are supported, but they must be selected using the control panel. For details about paper size settings, see p.122 "Specifying standard size paper for a standard or optional paper feed tray".</p> <p>Region A</p> <p>A5, A6, B6 JIS, 8 1/2" x 13" (Foolscap), 8 1/4" x 13" (Folio), 8" x 13" (F/GL), 7 1/4" x 10 1/2" (Executive), 5 1/2" x 8 1/2" (Half Letter), 4 1/8" x 9 1/2" (Com10), 3 7/8" x 7 1/2" (Monarch), C5 Env., C6 Env., DL Env., 16K, Custom Size</p> <p>Region B</p> <p>A5, A6, B6 JIS, 8 1/2" x 13" (Foolscap), 8 1/4" x 13" (Folio), 8" x 13" (F/GL), 7 1/4" x 10 1/2" (Executive), 5 1/2" x 8 1/2" (Half Letter), 4 1/8" x 9 1/2" (Com10), 3 7/8" x 7 1/2" (Monarch), C5 Env., C6 Env., DL Env., 16K, Custom Size</p> |
| <p>Custom paper size</p> | <p>The following custom sizes are supported, but they must be selected using the control panel. For details about custom size paper settings, see p.123 "Specifying custom size paper for a standard or optional paper feed tray".</p> <ul style="list-style-type: none"> • Approximately 98 - 216 mm (3.86 - 8.50 inches) in width • Approximately 140 - 356 mm (5.52 - 14.01 inches) in length |
| <p>Paper weight</p> | <p>52 to 220 g/m² (14 to 59 lb.)</p> |
| <p>Paper capacity</p> | <p>550 sheets (75 g/m², 20 lb.)</p> <p>Do not load the paper so that the top of the stack exceeds the limit mark inside the tray.</p> |

Optional Paper Feed Tray

| | |
|--------------------|--|
| <p>Paper types</p> | <p>Plain Paper, Middle Thick, Thick Paper 1, Thick Paper 2, Thick Paper 3, Thin Paper, Letterhead, Label Paper, Special Paper 1, Special Paper 2, Special Paper 3, Preprinted Paper, Color Paper, Recycled Paper</p> |
|--------------------|--|

| | |
|---------------------------------------|---|
| Automatically selected paper sizes | <p>The following paper sizes are supported by this printer's automatic paper size detection function:</p> <p> Region A A4, A5, B5, 8 1/2" x 14" (Legal), 8 1/2" x 11" (Letter)</p> <p> Region B A4, B5, 8 1/2" x 14" (Legal), 8 1/2" x 11" (Letter), 5 1/2" x 8 1/2" (Half Letter)</p> <p>For details about paper size settings, see p. 121 "Specifying paper size automatically for a standard or optional paper feed tray".</p> |
| Paper sizes requiring manual settings | <p>The following sizes are supported, but they must be selected using the control panel. For details about paper size settings, see p. 122 "Specifying standard size paper for a standard or optional paper feed tray".</p> <p> Region A B6 JIS, 8 1/2" x 13" (Foolscap), 8 1/4" x 13" (Folio), 8" x 13" (F/GL), 7 1/4" x 10 1/2" (Executive), 5 1/2" x 8 1/2" (Half Letter), 4 1/8" x 9 1/2" (Com10), 3 7/8" x 7 1/2" (Monarch), C5 Env., C6 Env., DL Env., 16K, Custom Size</p> <p> Region B A5, B6 JIS, 8 1/2" x 13" (Foolscap), 8 1/4" x 13" (Folio), 8" x 13" (F/GL), 7 1/4" x 10 1/2" (Executive), 4 1/8" x 9 1/2" (Com10), 3 7/8" x 7 1/2" (Monarch), C5 Env., C6 Env., DL Env., 16K, Custom Size</p> |
| Custom paper size | <p>The following custom sizes are supported, but they must be selected using the control panel. For details about custom size paper settings, see p. 123 "Specifying custom size paper for a standard or optional paper feed tray".</p> <ul style="list-style-type: none"> • Approximately 98 - 216 mm (3.86 - 8.50 inches) in width • Approximately 160 - 356 mm (6.30 - 14.01 inches) in length |
| Paper weight | 52 to 220 g/m ² (14 to 59 lb.) |
| Paper capacity | 550 sheets (75 g/m ² , 20 lb.) Do not load the paper so that the top of the stack exceeds the limit mark inside the tray. |

Bypass Tray

| | |
|---------------------------------------|--|
| Paper types | Plain Paper, Middle Thick, Thick Paper 1, Thick Paper 2, Thick Paper 3, Thin Paper, Letterhead, Label Paper, Special Paper 1, Special Paper 2, Special Paper 3, Preprinted Paper, Color Paper, Recycled Paper, OHP (Transparency), Envelope |
| Paper sizes requiring manual settings | The following sizes are supported, but they must be selected using the control panel. For details about paper size settings, see p.127 "Specifying standard size paper for the bypass tray". A4, A5, A6, B5 JIS, B6 JIS, 8 1/2" x 14" (Legal), 8 1/2" x 13" (Foolscap), 8 1/2" x 11" (Letter), 8 1/4" x 13" (Folio), 8" x 13" (F/GL), 7 1/4" x 10 1/2" (Executive), 5 1/2" x 8 1/2" (Half Letter), 4 1/8" x 9 1/2" (Com 10), 3 7/8" x 7 1/2" (Monarch), C5 Env., C6 Env., DL Env., 16K, Custom Size |
| Custom paper size | The following custom sizes are supported, but they must be selected using the control panel. For details about custom size paper settings, see p.129 "Specifying custom size paper for the bypass tray". <ul style="list-style-type: none"> Approximately 64 - 216 mm (2.52 - 8.50 inches) in width Approximately 140 - 900 mm (5.52 - 35.43 inches) in length |
| Paper weight | 52 to 220 g/m ² (14 to 59 lb.) |
| Paper capacity | 100 sheets (75 g/m ² , 20 lb.) Do not load the paper so that the top of the stack exceeds the paper guides on the bypass tray. |

Note

- When a custom size is specified, duplex printing is possible on paper whose length is between 160 and 356 mm (6.3 and 14.1 inches).

Supported Paper Types

The tables in this section provide details of the paper types supported by this printer. Use these tables when specifying a tray's paper settings and take note of the information under "Note".

Plain Paper

| | |
|---|--|
| Paper weight | 60 to 90 g/m ² (16 to 24 lb.) |
| Paper type setting using the control panel | The [Menu] key > [Paper Input] > [Paper Type: (tray name)] > [No Display (Plain Paper)] > the [OK] key |
| Paper type setting using the printer driver | [Plain & Recycled] or [Plain (60 to 90 g/m ²)] |
| Supported input tray | Any input tray can be used. |
| Duplex printing | Supported |
| Maintenance | <ul style="list-style-type: none"> [Plain Paper 1]: 60 to 69 g/m² (16 to 18 lb.) [Plain Paper 2]: 70 to 90 g/m² (19 to 24 lb.) <p>Default: [Plain Paper 2]</p> <p>If prints made using the paper tray show heavy smudging, use the following procedure to change the paper type setting from the control panel:</p> <ul style="list-style-type: none"> Press the [Menu] key, select [Maintenance], [General Settings], and then select [Plain Paper Setting]. Select the paper tray, and then select [Plain Paper 1] or [Plain Paper 2]. <p>When specifying paper thickness, remember that a higher number indicates greater thickness. Also, because the paper thickness will normally be detected automatically, change this setting only if a print problem occurs.</p> |
| Note | <ul style="list-style-type: none"> Tray 1: 550 Tray 2 (Paper feed unit): 550 Tray 3 (Paper feed unit): 550 Tray 4 (Paper feed unit): 550 Tray 5 (Paper feed unit): 550 Bypass Tray: 100 |

Middle Thick

| | |
|---|--|
| Paper weight | 91 to 105 g/m ² (24 to 28 lb.) |
| Paper type setting using the control panel | The [Menu] key > [Paper Input] > [Paper Type: (tray name)] > [Middle Thick] > the [OK] key |
| Paper type setting using the printer driver | [Middle Thick (91 to 105 g/m ²)] |
| Supported input tray | Any input tray can be used. |
| Duplex printing | Supported |

Thick Paper

| | |
|---|---|
| Paper weight | 106 to 220 g/m ² (28 to 59 lb.) |
| Paper type setting using the control panel | <ul style="list-style-type: none"> The [Menu] key > [Paper Input] > [Paper Type: (tray name)] > [Thick Paper 1] or [Thick Paper 2] or [Thick Paper 3] > the [OK] key <ul style="list-style-type: none"> [Thick Paper 1]: 106 to 130 g/m² (28 to 35 lb.) [Thick Paper 2]: 131 to 163 g/m² (35 to 43 lb.) [Thick Paper 3]: 164 to 220 g/m² (44 to 59 lb.) |
| Paper type setting using the printer driver | <ul style="list-style-type: none"> [Thick Paper 1]: [Thick 1 (106 to 130 g/m²)] [Thick Paper 2]: [Thick 2 (131 to 163 g/m²)] [Thick Paper 3]: [Thick 3 (164 to 220 g/m²)] |
| Supported input tray | [Thick Paper 1], [Thick Paper 2], [Thick Paper 3]: Any input tray can be used. |
| Duplex printing | <ul style="list-style-type: none"> [Thick Paper 1], [Thick Paper 2]: Supported [Thick Paper 3]: Not supported |
| Note | Printing is slightly slower than when using plain paper. |

Thin Paper

| | |
|--------------|--|
| Paper weight | 52 to 59 g/m ² (14 to 16 lb.) |
|--------------|--|

| | |
|---|--|
| Paper type setting using the control panel | The [Menu] key > [Paper Input] > [Paper Type: (tray name)] > [Thin Paper] > the [OK] key |
| Paper type setting using the printer driver | [Thin (52 to 59 g/m ²)] |
| Supported input tray | Any input tray can be used. |
| Duplex printing | Not supported |

Letterhead

| | |
|---|---|
| Paper type setting using the control panel | The [Menu] key > [Paper Input] > [Paper Type: (tray name)] > [Letterhead] > the [OK] key |
| Paper type setting using the printer driver | [Letterhead] |
| Supported input tray | Any input tray can be used. |
| Maintenance | <p>Default: [Letterhead 1]</p> <ul style="list-style-type: none"> • [Letterhead 1] • [Letterhead 2] • [Letterhead 3] <p>If prints made using the paper tray show heavy smudging, use the following procedure to change the paper type setting from the control panel:</p> <ul style="list-style-type: none"> • Press the [Menu] key, select [Maintenance], [General Settings], and then select [Letterhead Setting]. Select the paper tray, and then select [Letterhead 1], [Letterhead 2], or [Letterhead 3]. <p>When specifying paper thickness, remember that a higher number indicates greater thickness. Also, because the paper thickness will normally be detected automatically, change this setting only if a print problem occurs.</p> |
| Duplex printing | Supported |

Label Paper

| | |
|---|--|
| Paper type setting using the control panel | The [Menu] key > [Paper Input] > [Paper Type: (tray name)] > [Label Paper] > the [OK] key |
| Paper type setting using the printer driver | [Labels] |
| Supported input tray | Any input tray can be used. |
| Maintenance | <p>Default: [Label Paper 1]</p> <ul style="list-style-type: none"> • [Label Paper 1] • [Label Paper 2] • [Label Paper 3] • [Label Paper 4] <p>If prints made using the paper tray show heavy smudging, use the following procedure to change the paper type setting from the control panel:</p> <ul style="list-style-type: none"> • Press the [Menu] key, select [Maintenance], [General Settings], [Label Paper Setting], and then select [Label Paper 1], [Label Paper 2], [Label Paper 3], or [Label Paper 4]. <p>When specifying paper thickness, remember that a higher number indicates greater thickness. Also, because the paper thickness will normally be detected automatically, change this setting only if a print problem occurs.</p> |
| Duplex printing | Not supported |

Special Paper

| | |
|--|--|
| Paper weight | 52 to 220 g/m ² (14 to 59 lb.) |
| Paper type setting using the control panel | <ul style="list-style-type: none"> • The [Menu] key > [Paper Input] > [Paper Type: (tray name)] > [Special Paper 1] or [Special Paper 2] or [Special Paper 3] > the [OK] key <ul style="list-style-type: none"> • [Special Paper 1]: 52 to 105 g/m² (14 to 28 lb.) • [Special Paper 2]: 106 to 163 g/m² (28 to 43 lb.) • [Special Paper 3]: 164 to 220 g/m² (44 to 59 lb.) |

| | |
|---|---|
| Paper type setting using the printer driver | [Special 1], [Special 2], [Special 3] |
| Supported input tray | Any input tray can be used. |
| Duplex printing | <ul style="list-style-type: none"> • [Special Paper 1], [Special Paper 2]: Supported • [Special Paper 3]: Not supported |
| Note | When you cannot print successfully with other paper type settings, set special paper. |

Preprinted Paper

| | |
|---|--|
| Paper type setting using the control panel | The [Menu] key > [Paper Input] > [Paper Type: (tray name)] > [Preprinted Paper] > the [OK] key |
| Paper type setting using the printer driver | [Preprinted] |
| Supported input tray | Any input tray can be used. |
| Duplex printing | Not Supported |

6

Color Paper

| | |
|---|---|
| Paper type setting using the control panel | The [Menu] key > [Paper Input] > [Paper Type: (tray name)] > [Color Paper] > the [OK] key |
| Paper type setting using the printer driver | [Color] |
| Supported input tray | Any input tray can be used. |
| Duplex printing | Supported |

Recycled Paper

| | |
|--|--|
| Paper type setting using the control panel | The [Menu] key > [Paper Input] > [Paper Type: (tray name)] > [Recycled Paper] > the [OK] key |
|--|--|

| | |
|---|----------------------------------|
| Paper type setting using the printer driver | [Recycled] or [Plain & Recycled] |
| Supported input tray | Any input tray can be used. |
| Duplex printing | Supported |

OHP transparencies

| | |
|---|--|
| Paper type setting using the control panel | The [Menu] key > [Paper Input] > [Paper Type: Bypass Tray] > [OHP (Transparency)] > the [OK] key |
| Paper type setting using the printer driver | [Transparency] |
| Supported input tray | This paper type can be printed only from the bypass tray. |
| Duplex printing | Not supported |

Envelopes

| | |
|---|--|
| Paper type setting using the control panel | The [Menu] key > [Paper Input] > [Paper Type: Bypass Tray] > [Envelope] > the [OK] key |
| Paper type setting using the printer driver | [Envelope] |
| Supported input tray | This paper type can be printed only from the bypass tray. |

| | |
|-----------------|---|
| Maintenance | <p>Default: [Envelope 3]</p> <ul style="list-style-type: none">• [Envelope 1]• [Envelope 2]• [Envelope 3]• [Envelope 4] <p>If prints made using the paper tray show heavy smudging, use the following procedure to change the paper type setting from the control panel:</p> <ul style="list-style-type: none">• Press the [Menu] key, select [Maintenance], [General Settings], [Envelope Setting], and then select [Envelope 1], [Envelope 2], [Envelope 3], or [Envelope 4]. <p>When specifying paper thickness, remember that a higher number indicates greater thickness. Also, because the paper thickness will normally be detected automatically, change this setting only if a print problem occurs.</p> |
| Duplex printing | Not supported |

Note

- Check there is no air in the envelopes before loading.
- Load only one size and type of envelope at a time.
- Some kinds of envelope might cause misfeeds, wrinkles or print poorly.
- Print quality on envelopes may be uneven if parts of an envelope have differing thicknesses. Print one or two envelopes to check print quality.
- In a hot and humid environment, the envelope might be output creased or improper printing quality.
- The number of envelopes that can be printed in one minute is approximately half that of Plain Paper 1.
- Paper can be loaded only up to the lower of the two paper limit marks of the bypass tray.
- If printed envelopes come out badly creased, load the envelopes in the opposite direction. Also, configure the printer driver to rotate the print object 180 degrees.
- Environmental factors can degrade the print quality on both recommend and non-recommended envelopes.
- After printing, envelopes sometimes have creases along their long edges and toner smear on their unprinted sides. Their print images might also be blurred. When printing large, black-solid areas, striping can occur as a result of the envelopes overlapping. If this occurs, use the envelope lever to resolve this problem. For more information about the envelope lever, see p.133 "Loading Envelopes".

 **Note**

- To correctly specify the length of an envelope whose flap opens along its short edge, be sure to include the open flap when measuring.

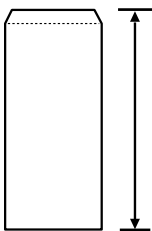

ASH125S

Storing Paper

Take care when storing paper. Improperly stored paper might result in poor print quality, paper misfeeds, or printer damage. Recommendations are as follows:

- Avoid storing paper in humid areas.
- Avoid exposing paper to direct sunlight.
- Store on a flat surface.
- Keep paper in its original package until time to use it.

Non-Recommended Paper Types

★ Important

- Do not use the following types of paper:

- Ink-jet printer paper
- GelJet special paper
- Bent, folded, or creased paper
- Curled or twisted paper
- Wet paper
- Paper that is dry enough to emit static electricity
- Paper that has already been printed onto, except a preprinted letterhead paper.

Malfunctions are especially likely when using paper printed on by other than a laser printer (e.g. monochrome and color copiers, ink-jet printers, etc.)

- Surface-processed paper (excluding specified paper)
- Special paper, such as thermal paper and carbon paper
- Paper whose weight is heavier or lighter than the limitation
- Perforated paper
- Adhesive label paper on which glue or base paper is exposed
- Paper with clips or staples
- Dirty or damaged paper

↓ Note

- Even if paper is adequate for the printer, poorly stored paper can cause paper misfeeds, print quality degradation, or malfunctions.

Print Area

Be sure to set the print margins correctly by the application.

The following diagram shows the print area for this printer.

Paper

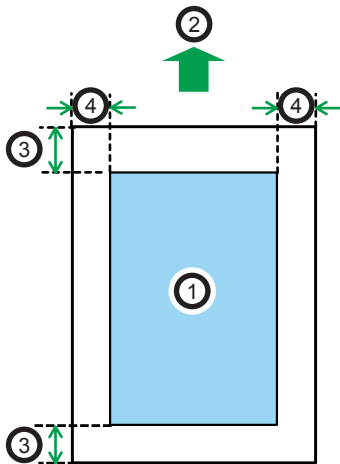

OEG244

- ① Print area
- ② Feed direction
- ③ Approx. 4.2 mm (0.2 inches)
- ④ Approx. 4.2 mm (0.2 inches)

↓ Note

- The print area may vary depending on the paper size, printer language and printer driver settings.

Envelope

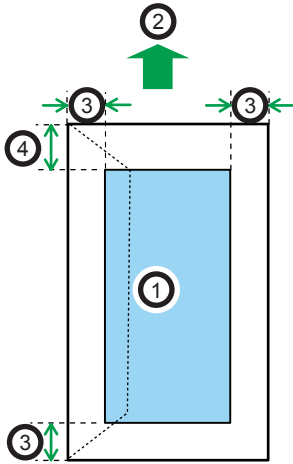

CEC245

- ① Print area
- ② Feed direction
- ③ Approx. 10 mm (0.4 inches)
- ④ Approx. 15 mm (0.6 inches)

↓ Note

- The print area may vary depending on the paper size, printer language and printer driver settings.

Loading Paper in Trays

Loading Paper into a Standard or Optional Paper Feed Tray

⚠ WARNING

- Do not put your hands inside the printer when the input tray is removed. Some internal parts become hot and are a burn hazard.

⚠ CAUTION

- Do not pull out the paper tray forcefully. If you do, the tray might fall and cause an injury.

⚠ CAUTION

- Take care to avoid cutting your hands when loading paper.

★ Important

- Make sure paper is not stacked higher than the upper limit mark inside the paper feed tray. Excessive stacking can cause paper jams.
- Do not mix different types of paper in the same paper tray.
- First load the paper in the tray, and then specify the paper type and size using the control panel. When printing a document, specify the paper size and type in the printer driver to the same settings used in the control panel.
- Do not move the side paper guides and end paper guide forcefully. Doing so can damage the tray.
- Curled paper may jam, straighten curled paper before loading.
- When loading paper, take care not to touch the surface of the paper.
- During printing, do not pull out or push in the paper tray.

1. Lift and pull tray carefully, and then pull it out with both hands.

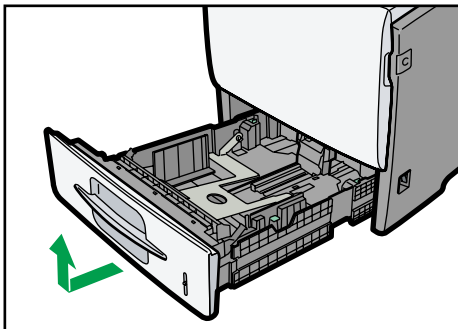

CEC031

Place the tray on a flat surface.

2. If you load paper larger than 8 1/2 " × 14 " (Legal) , you should extend the tray as follows:

1. Slide the catches inwards to unlock the tray.

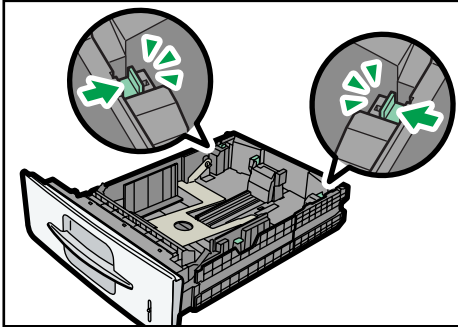

CEC007

2. Slide the tray until it stops.

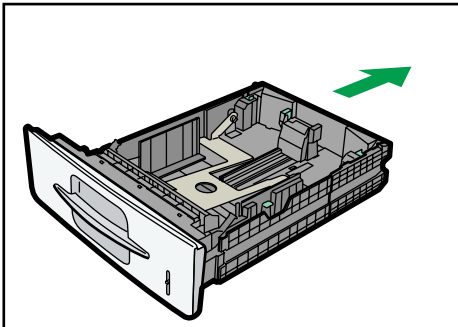

CEC008

3. Return the catches to their original positions.

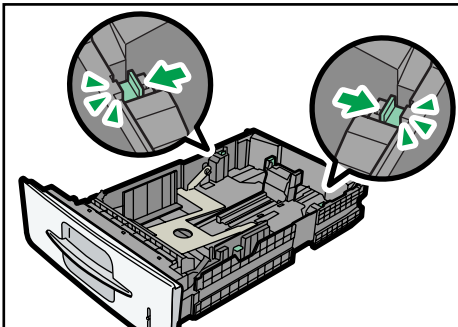

CEC009

3. Pinch the clip on the side paper guide and slide it to match the standard size.

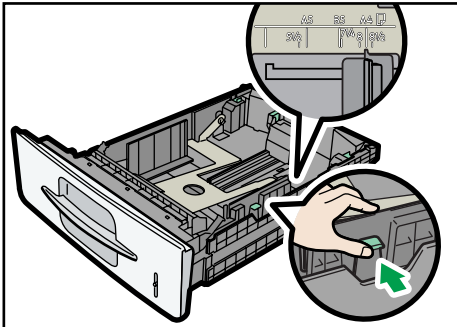

CEC010

4. Pinch the end guide and slide it inward to match the standard size.

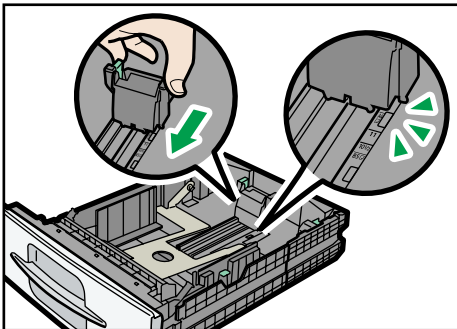

CEC011

5. Set the paper thickness setting switch on the front side of the paper tray according to the type of the loaded paper.

When loading paper thicker than 105 g/m² (28 lb.), slide the switch to the left.

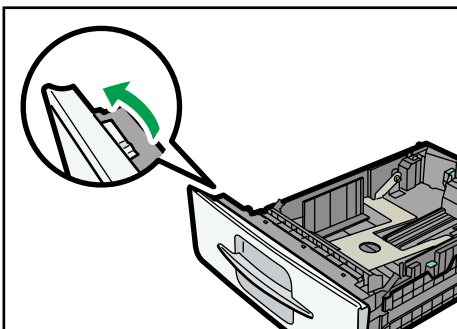

CEC253

6. Fan the paper before loading paper in the tray.

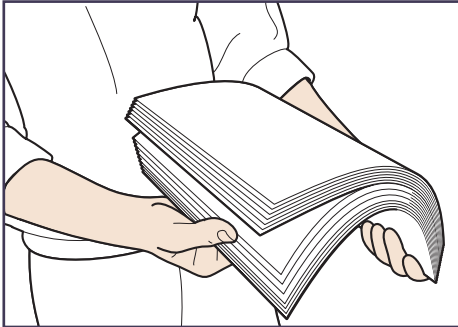

CBK254

7. Load the new paper stack print side down.

Make sure paper is not stacked higher than the upper limit (upper line) marked inside the tray.

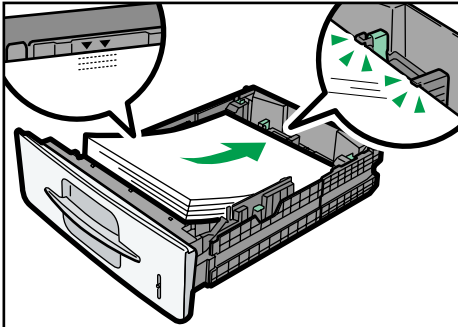

CEC006

Slide the guides inward, until they are flush against the paper's sides.

8. Adjust the paper guides to close any gaps.

Do not move paper loaded in the tray more than a few millimeters.

Moving the loaded paper excessively can cause damage to paper edges on the openings of the tray's lifting plate, resulting in sheets being folded or becoming jammed.

9. Hold the tray with both hands, slide it along the rails of the printer body, and then push it straight in.

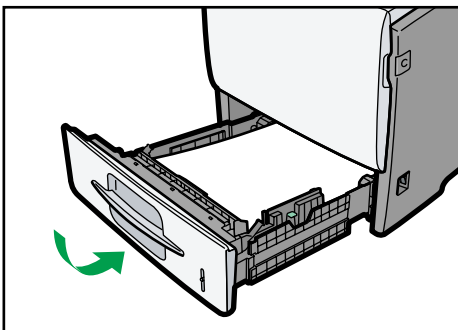

CEC032

To avoid paper jams, make sure the tray is securely inserted.

Specifying paper size automatically for a standard or optional paper feed tray

1. Press the [Menu] key.

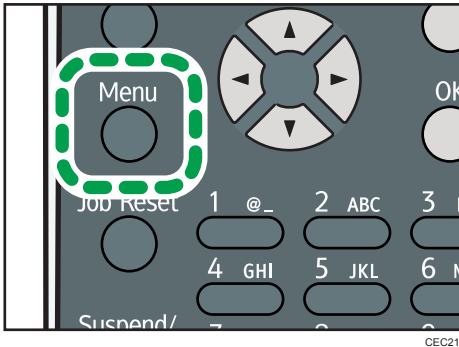

2. Press the [▼] or [▲] key to select [Paper Input], and then press the [OK] key.

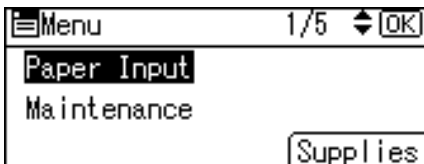

3. Press the [▼] or [▲] key to select [Paper Size: (tray name)], and then press the [OK] key.



4. Select [Auto Detect] using the scroll keys, and then press the [OK] key.

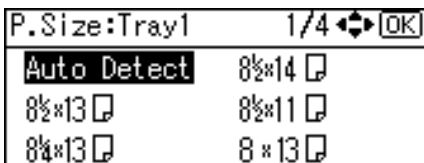

5. Press the [Menu] key to return to the initial screen.

↓ Note

- For details about the available paper sizes, see p.101 "Supported Paper for Each Tray".

Specifying standard size paper for a standard or optional paper feed tray

1. Press the [Menu] key.

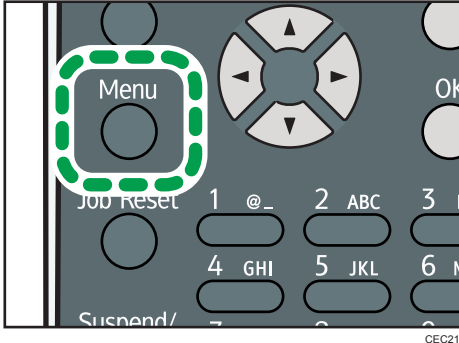

2. Press the [▼] or [▲] key to select [Paper Input], and then press the [OK] key.

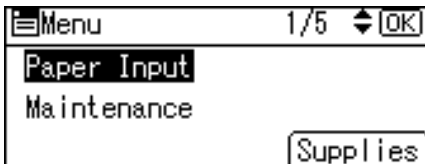

3. Press the [▼] or [▲] key to select [Paper Size: (tray name)], and then press the [OK] key.

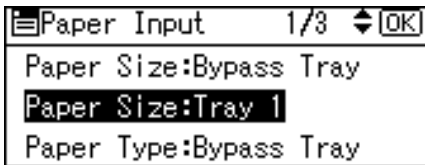

4. Select the paper size you want to set using the scroll keys, and then press the [OK] key.

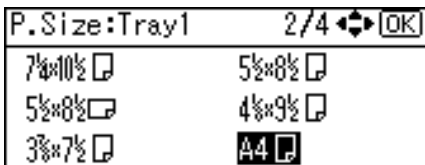

5. Press the [Menu] key to return to the initial screen.

Note

- For details about the available paper size, see p.101 "Supported Paper for Each Tray".
- After specifying the paper size, specify a paper type using the control panel and printer driver. For details on specifying a paper type using the control panel, p.124 "Specifying a paper type for standard or optional paper feed tray".
- For details about the printer driver, see the printer driver Help.

Specifying custom size paper for a standard or optional paper feed tray

★ Important

- The printer cannot print from applications that do not support custom size paper.

1. Press the [Menu] key.

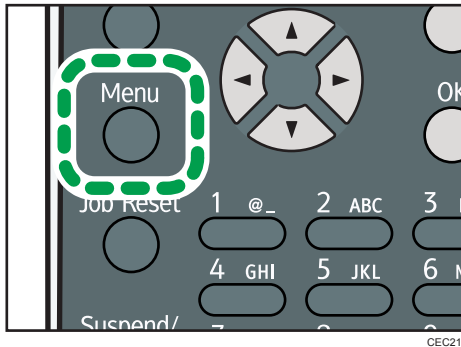

2. Press the [▼] or [▲] key to select [Paper Input], and then press the [OK] key.

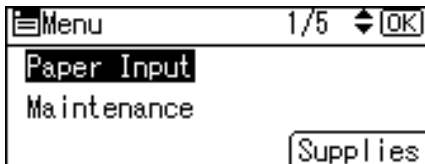

3. Press the [▼] or [▲] key to select [Paper Size: (tray name)], and then press the [OK] key.
In the illustration below, [Paper Size:Tray 1] is selected for Tray 1.



4. Select [Custom Size] using the scroll keys, and then press the [OK] key.

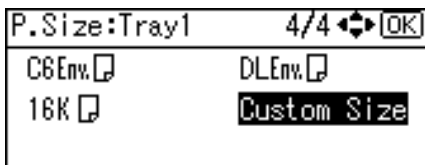

5. Enter the horizontal value, and then press the [OK] key.

 **Region A** (mainly Europe and Asia)

| | |
|---------------------------|---------------------------------------|
| Custom:Tray1 | ↕ [OK] |
| Enter with No. keys or ↕. | |
| Horiz. | <input type="text" value="215.9"/> mm |
| <98.0to216.0 by 0.1> | |

 **Region B** (mainly North America)

| | |
|---------------------------|--|
| Custom:Tray1 | ↕ [OK] |
| Enter with No. keys or ↕. | |
| Horiz. | <input type="text" value="8.50"/> inch |
| <3.86to8.50 by 0.01> | |

6. Enter the vertical value, and then press the [OK] key.

 **Region A** (mainly Europe and Asia)

| | |
|---------------------------|---------------------------------------|
| Custom:Tray1 | ↕ [OK] |
| Enter with No. keys or ↕. | |
| Vert. | <input type="text" value="279.4"/> mm |
| <140.0to356.0 by 0.1> | |

 **Region B** (mainly North America)

| | |
|---------------------------|---|
| Custom:Tray1 | ↕ [OK] |
| Enter with No. keys or ↕. | |
| Vert. | <input type="text" value="11.00"/> inch |
| <5.52to14.01 by 0.01> | |

7. Press the [Menu] key to return to the initial screen.

Note

- For details about the available paper size, see p.101 "Supported Paper for Each Tray".
- After specifying the paper size, specify a paper type using the control panel and printer driver. For details on specifying a paper type using the control panel, p.124 "Specifying a paper type for standard or optional paper feed tray".
- For details about the printer driver, see the printer driver Help.

Specifying a paper type for standard or optional paper feed tray

You can improve printer performance by selecting the optimum paper type for the tray.

1. Press the [Menu] key.

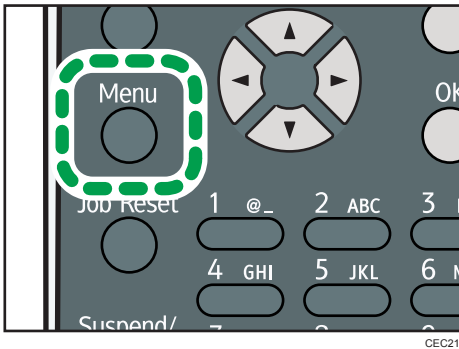

2. Press the [▼] or [▲] key to select [Paper Input], and then press the [OK] key.

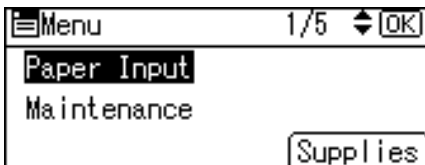

3. Press the [▼] or [▲] key to select [Paper Type: (tray name)], and then press the [OK] key.
In the illustration below, [Paper Type:Tray 1] is selected for Tray 1.

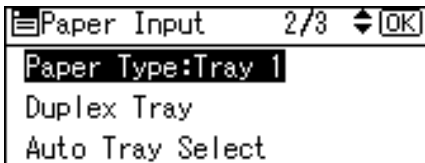

4. Press the [▼] or [▲] key to select the paper type that is loaded, and then press the [OK] key.

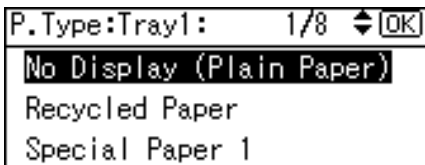

About two seconds later, the display returns to the Paper Input screen.

5. Press the [Menu] key to return to the initial screen.

↓ Note

- If the printing result is badly smudged, change the setting on the printer's control panel. For details, see p.101 "Supported Paper for Each Tray".

Loading Paper onto Bypass Tray

★ Important

- Shuffle paper before loading the stack onto the tray, so multiple sheets are not fed in together.
- Set the size and direction of the loaded paper on the control panel or in the printer driver. Make sure the settings do not conflict. Otherwise, the paper may jam or the print quality may be affected.
- Load paper with the print side up.
- During printing, do not open or close the printer covers or bypass tray, or pull out or push in the paper tray.

1. Hold the both sides of the bypass tray and pull it toward you.

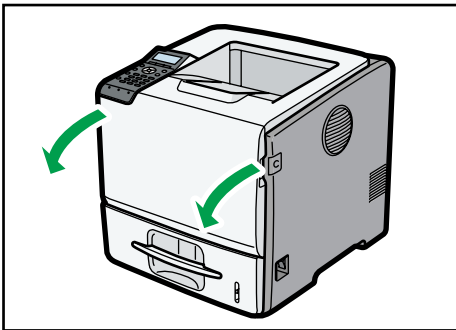

CEC217

If you load A4 and 8 1/2" x 11" (Letter) size paper or longer, pull out the bypass tray extension.

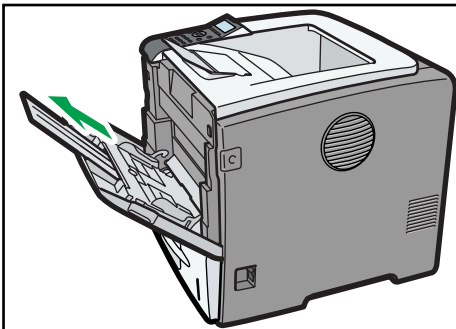

CEC023

2. Slide the paper guide both sides outward, and then load paper print side up, until it stops.

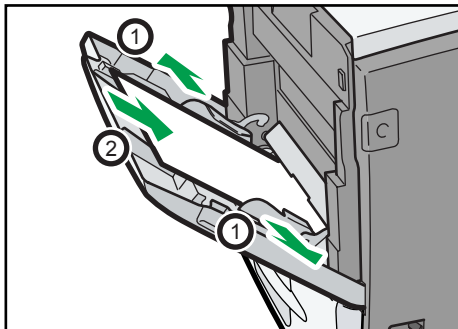

CEC022

3. Adjust the paper guide both sides to fit the paper width.

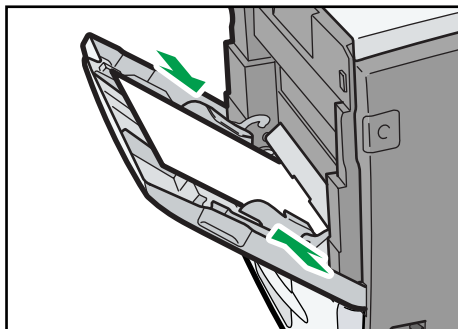

CEC024

↓ Note

- When loading paper on the bypass tray, make sure the stack does not exceed the limit mark on the inner side of the paper guides. For details about the thicknesses of different paper types, see p. 105 "Supported Paper Types".

Specifying standard size paper for the bypass tray

★ Important

- The standard size paper selected using the printer driver overrides that selected using the control panel, so do not make settings using the control panel if you have already made settings using the printer driver.
- When [Machine Setting(s)] is selected for [Tray Setting Priority] under [Machine Modes] in [Print Settings], any settings made using the printer's control panel have priority over any settings made using the printer driver.
- For details about the printer driver, see the printer driver Help.

1. Press the [Menu] key.

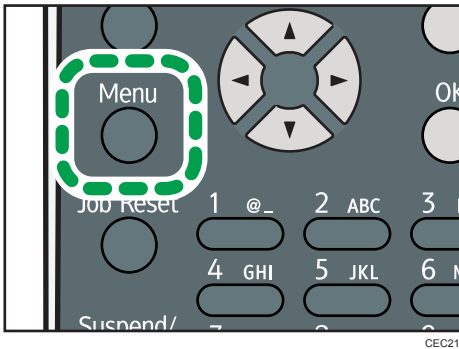

2. Press the [▼] or [▲] key to select [Paper Input], and then press the [OK] key.

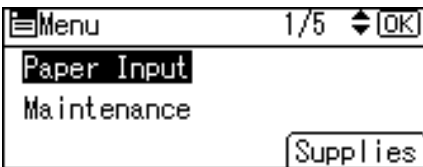

3. Press the [▼] or [▲] key to select [Paper Size:Bypass Tray], and then press the [OK] key.

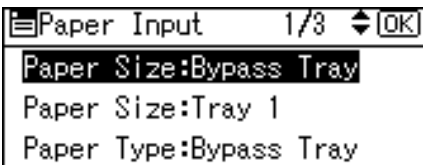

4. Select the paper size you want to set using the scroll keys, and then press the [OK] key.

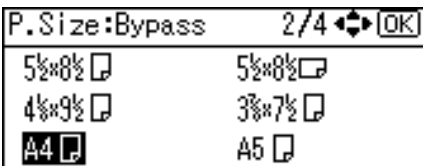

5. Press the [Menu] key to return to the initial screen.

Note

- After specifying the paper size, specify a paper type using the control panel or printer driver. For details on specifying a paper type using the control panel, see p.131 "Specifying a paper type for the bypass tray".
- The number of pages that can be loaded on the bypass tray differs depending on paper type.
- For details about the printer driver, see the printer driver Help.

Specifying custom size paper for the bypass tray

★ Important

- The custom size paper selected using the printer driver overrides that selected using the control panel, so do not make settings using the control panel if you have already made settings using the printer driver.
- When [Machine Setting(s)] is selected for [Tray Setting Priority] under [Machine Modes] in [Print Settings], any settings made using the printer's control panel have priority over any settings made using the printer driver.
- You cannot print on custom size paper with an application that does not support the custom size setting.
- For details about the printer driver, see the printer driver Help.

1. Press the [Menu] key.

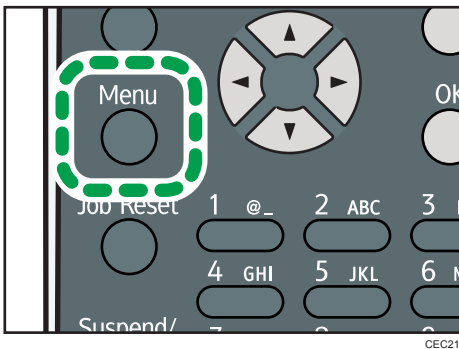

2. Press the [▼] or [▲] key to select [Paper Input], and then press the [OK] key.

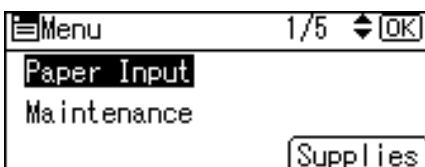

3. Press the [▼] or [▲] key to select [Paper Size:Bypass Tray], and then press the [OK] key.



4. Select [Custom Size] using the scroll keys, and then press the [OK] key.

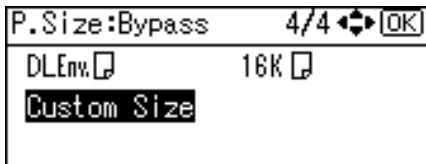

5. Enter the horizontal value, and then press the [OK] key.

 **Region A** (mainly Europe and Asia)

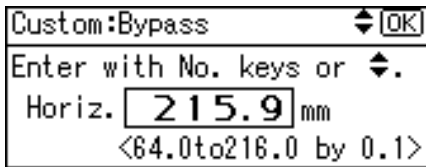

 **Region B** (mainly North America)

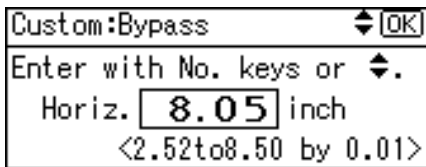

6. Enter the vertical value, and then press the [OK] key.

 **Region A** (mainly Europe and Asia)

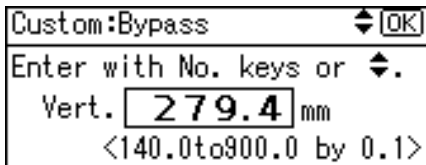

 **Region B** (mainly North America)

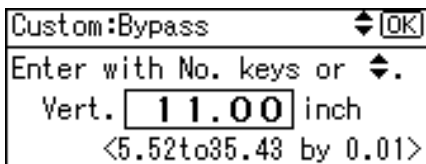

7. Press the [Menu] key to return to the initial screen.

 **Note**

- After specifying the paper size, specify a paper type using the control panel or printer driver. For details on specifying a paper type using the control panel, see p.131 "Specifying a paper type for the bypass tray".
- For details about the printer driver, see the printer driver Help.

Specifying a paper type for the bypass tray

★ Important

- After loading paper on the tray, specify the paper type using the control panel or printer driver.
- The paper type selected using the printer driver overrides that selected using the control panel, so do not make settings using the control panel if you have already made settings using the printer driver.
- When [Machine Setting(s)] is selected for [Tray Setting Priority] under [Machine Modes] in [Print Settings], any settings made using the printer's control panel have priority over any settings made using the printer driver.
- For details about the printer driver, see the printer driver Help.

1. Press the [Menu] key.

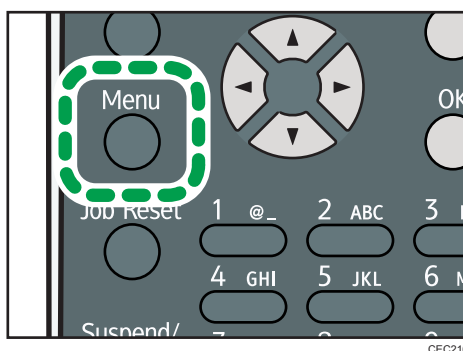

2. Press the [▼] or [▲] key to select [Paper Input], and then press the [OK] key.

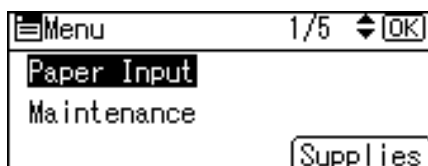

3. Press the [▼] or [▲] key to select [Paper Type:Bypass Tray] and then press the [OK] key.



4. Press the [▼] or [▲] key to select the paper type you want to use, and then press the [OK] key.

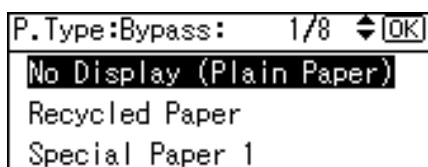

5. Press the [Menu] key to return to the initial screen.

↓ Note

- If the printing result is badly smudged, change the setting on the printer's control panel. For details, see p.101 "Supported Paper for Each Tray".

Loading Envelopes

⚠ CAUTION

- The inside of the machine could be very hot. Do not touch the parts with a label indicating the "hot surface". Otherwise, an injury might occur.

⚠ CAUTION

- Some of this machine's internal components get very hot. For this reason, take care when removing misfed paper. Not doing so could result in burns.

★ Important

- Check there is no air in the envelopes before loading.
- Load only one size and type of envelope at a time.
- Before loading envelopes, flatten their leading edges (the edge going into the printer) by running a pencil or ruler across them.
- Some kinds of envelope might cause misfeeds, wrinkles or print poorly.
- Print quality on envelopes may be uneven if parts of an envelope have differing thicknesses. Print one or two envelopes to check print quality.
- In a hot and humid environment, the envelope might be output creased or improper printing quality.

Loading Envelopes onto Bypass Tray

1. Open the rear cover.

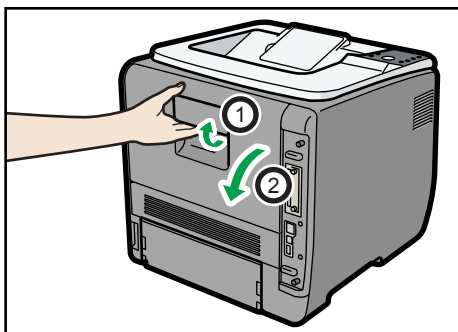

CEC046

2. Use the envelope lever.

Raising the envelope lever reduces roller pressure.

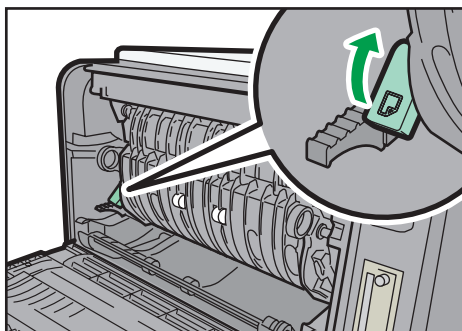

CEC033

3. Close the rear cover.

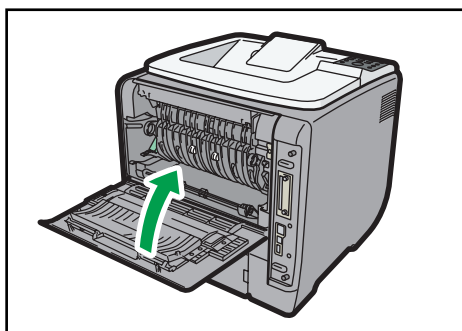

CEC049

4. Hold the both sides of the bypass tray and pull it toward you.

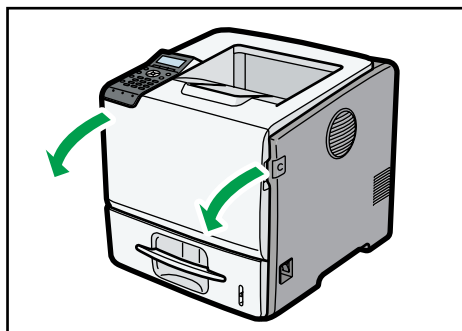

CEC217

5. Fan envelopes, and then align their edges before loading.

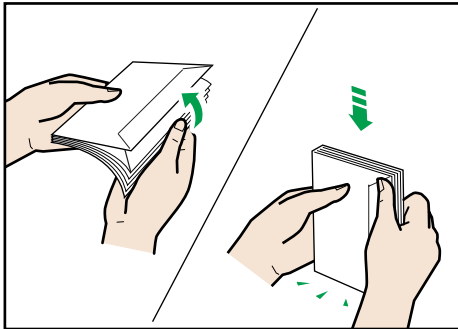

CBK239

When fanning envelopes, make sure the envelope flaps are not stuck together. If they are stuck together, separate them.

Before loading envelopes, flatten them out so that their curl does not exceed that shown in the illustration below.

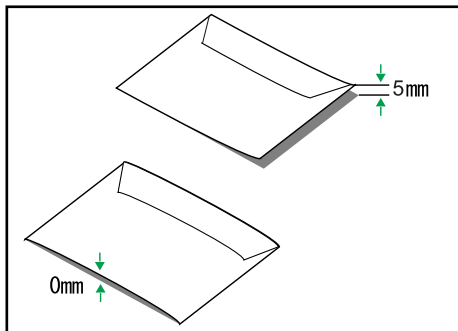

CBK240

If the curl is severe, flatten out the envelopes using your fingers, as shown in the illustration below.

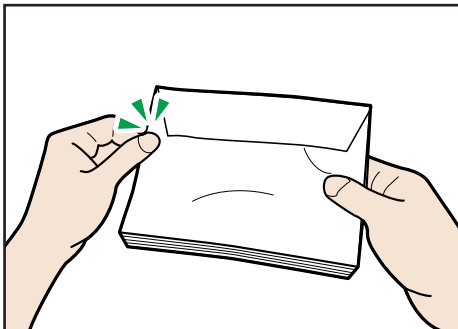

CBK241

If envelopes are severely curled after printing, flatten them by bending them back against the curl.

6. Set the envelope in bypass tray with the printing side facing up.

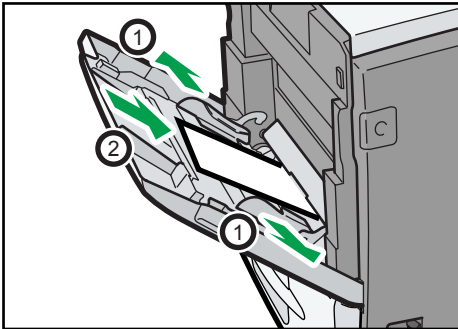

CEC218

7. Adjust the paper guide both sides to fit the envelope width.

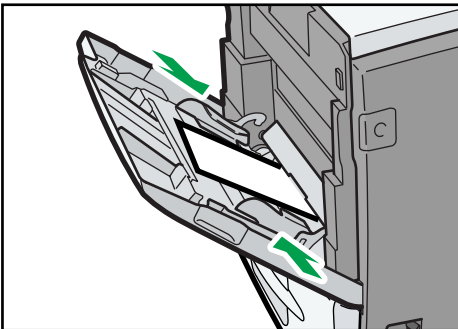

CEC219

↓ Note

- Keep the envelope lever lowered when printing normally.

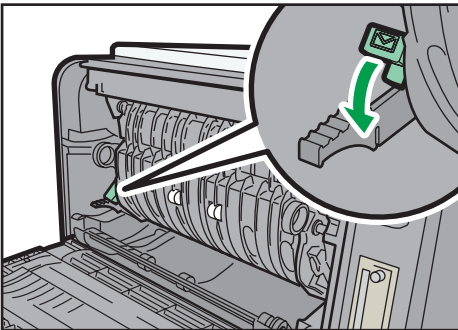

CEC034

Specifying envelope size for the bypass tray

★ Important

- The envelope size selected using the printer driver overrides that selected using the control panel, so do not make settings using the control panel if you have already made settings using the printer driver.

- When [Machine Setting(s)] is selected for [Tray Setting Priority] under [Machine Modes] in [Print Settings], any settings made using the printer's control panel have priority over any settings made using the printer driver.
- For details about the printer driver, see the printer driver Help.

1. Press the [Menu] key.

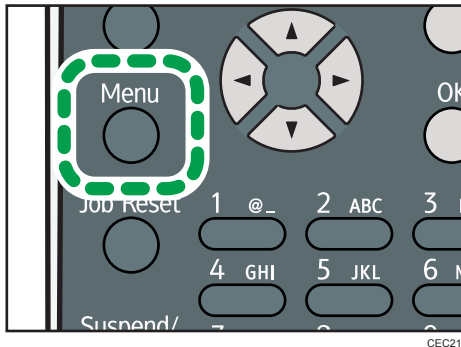

2. Press the [▼] or [▲] key to select [Paper Input], and then press the [OK] key.

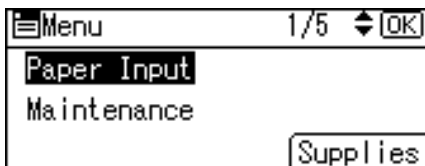

3. Press the [▼] or [▲] key to select [Paper Size:Bypass Tray], and then press the [OK] key.

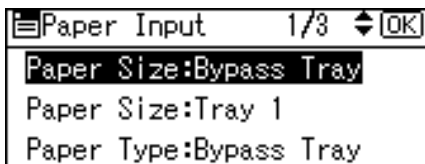

4. Select the envelope type using the scroll keys, and then press the [OK] key.

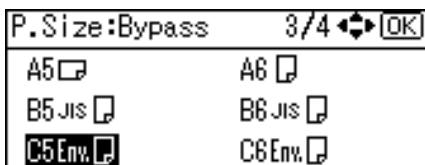

5. Press the [Menu] key.

↓ Note

- Confirm that the top of the stack is not higher than the limit mark on the side guides.
- Do not push the stack of envelopes with too much force.
- Confirm that the edges of envelopes fit under the side guides.

- After specifying the paper size, specify a paper type such as [Envelope] using the control panel or printer driver. For details on specifying a paper type using the control panel, see p.131 "Specifying a paper type for the bypass tray".
- For details about the printer driver, see the printer driver Help.

Loading Envelopes into a Standard or Optional Paper Feed Tray

1. Open the rear cover.

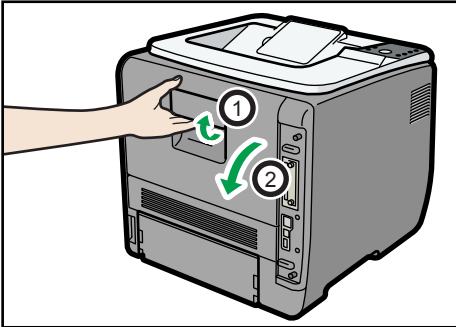

CEC046

2. Use the envelope lever.

Raising the envelope lever reduces roller pressure.

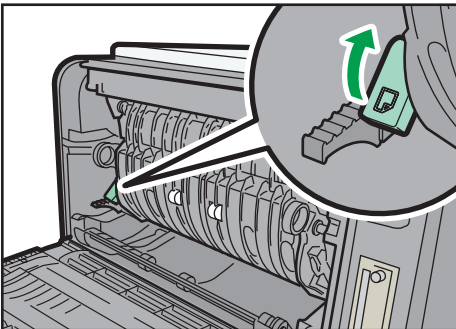

CEC033

3. Close the rear cover.

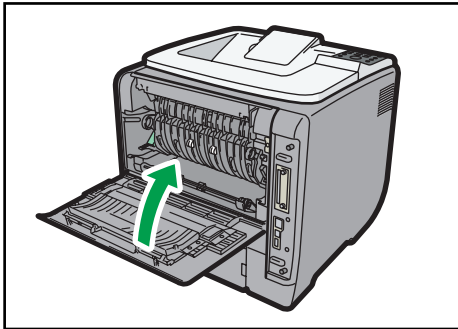

CEC049

4. Lift and pull tray carefully, and then pull it out with both hands.

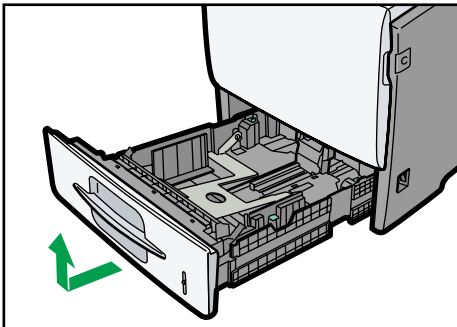

CEC031

Place the tray on a flat surface.

5. Pinch the side guides, and then slide them outward until they stop.

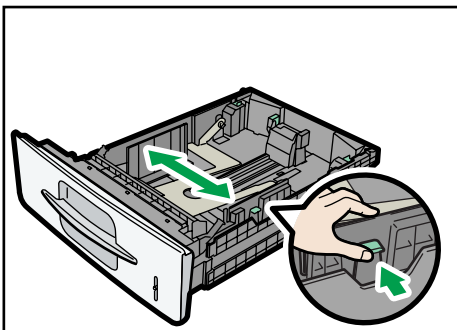

CEC263

6. Pinch the rear guide, and then slide it toward the back.

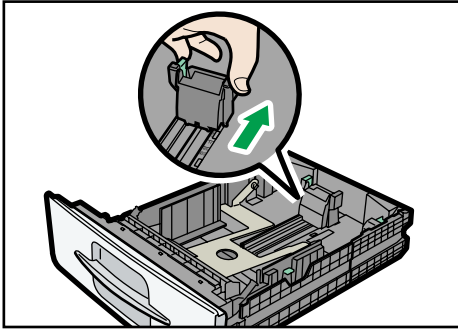

CEC264

7. Set the paper thickness setting switch on the front side of the paper tray according to the type of the loaded paper.

When loading paper thicker than 105 g/m² (28 lb.), slide the switch to the left.

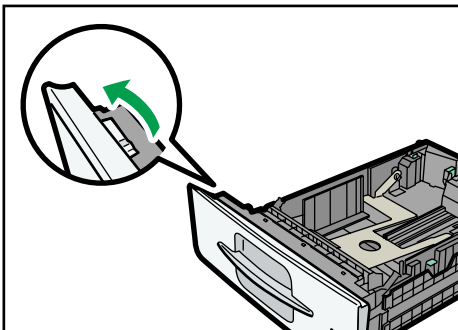

CEC253

8. Fan envelopes, and then align their edges before loading.

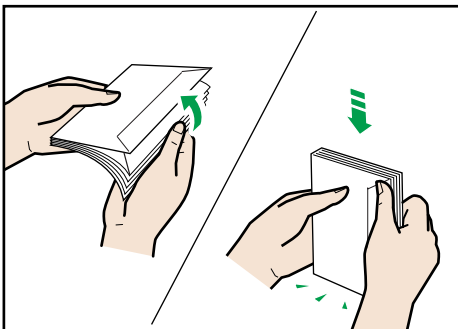

CBK239

When fanning envelopes, make sure the envelope flaps are not stuck together. If they are stuck together, separate them.

Before loading envelopes, flatten them out so that their curl does not exceed that shown in the illustration below.

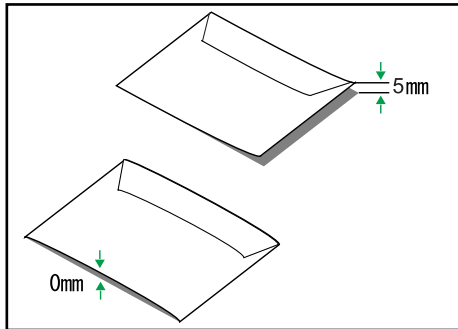

CBK240

If the curl is severe, flatten out the envelopes using your fingers, as shown in the illustration below.

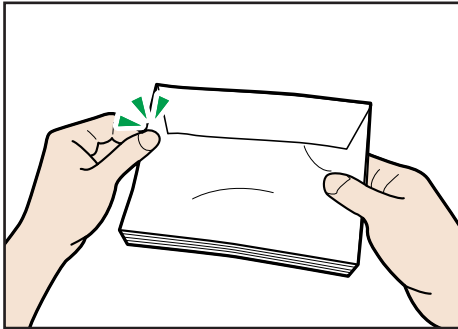

CBK241

If envelopes are severely curled after printing, flatten them by bending them back against the curl.

9. Load envelopes into the paper tray, with the print side down and the flap on the left as shown in the illustration.

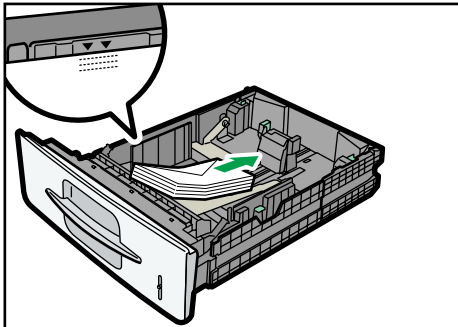

CEC262

10. Pinch the side guides, and then slide them along the edge of the envelope stack.

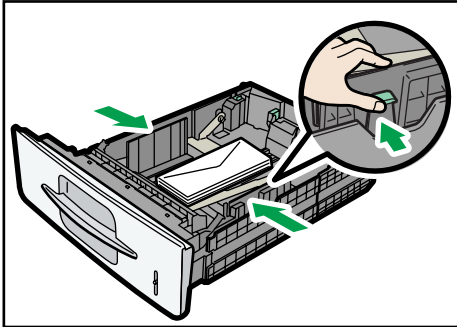

CEC265

11. Pinch the rear guide, and then slide it along the edge of the envelope stack.

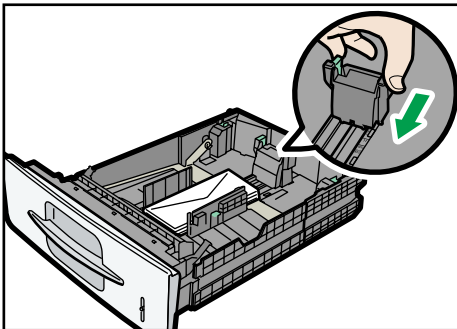

CEC266

12. Hold the tray with both hands, slide it along the rails of the printer body, and then push it straight in.

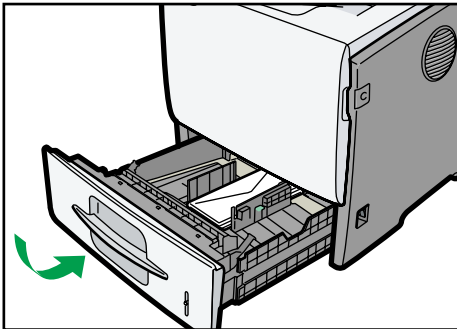

CEC267

Note

- Keep the envelope lever lowered when printing normally.

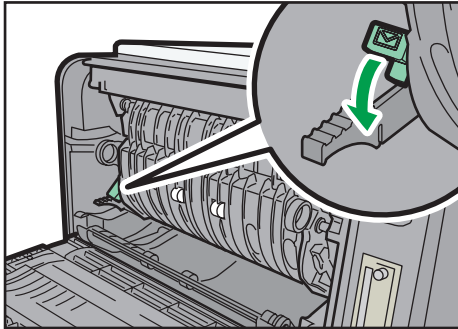

CEC034

Specifying envelope size for a standard or optional paper feed tray

1. Press the [Menu] key.

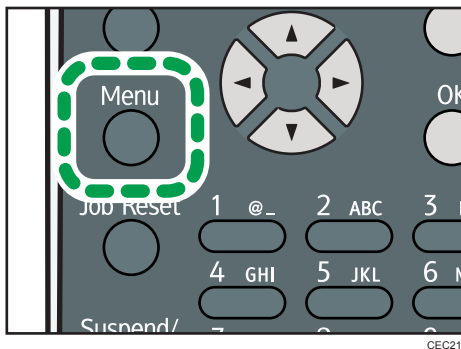

CEC216

2. Press the [▼] or [▲] key to select [Paper Input], and then press the [OK] key.

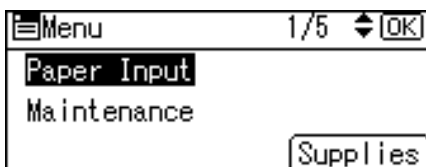

3. Press the [▼] or [▲] key to select [Paper Size: (tray name)], and then press the [OK] key.



4. Select the envelope size you want to set using the scroll keys, and then press the [OK] key.
5. Press the [Menu] key to return to the initial screen.

↓ Note

- For details about the available paper size, see p.101 "Supported Paper for Each Tray".

- After specifying the paper size, specify a paper type such as [Thick Paper 2] using the control panel and printer driver. For details on specifying a paper type using the control panel, p.124 "Specifying a paper type for standard or optional paper feed tray".
- For details about the printer driver, see the printer driver Help.

Printing on Fixed-Orientation Paper

This section explains how to print on paper whose orientation and printing side are unchangeable (letterhead paper, for example).

When loading paper with a fixed orientation, such as letterhead or letter paper, misprints may occur.

The following table shows the printout result according to the combination of paper feed direction and letterhead settings in the control panel and PCL printer driver.

| Paper Orientation | Paper trays 1-5 | | Bypass Tray | |
|--------------------|----------------------------|-----------------------------|----------------------------|-----------------------------|
| | Letterhead Setting [On] | Letterhead Setting [Off] | Letterhead Setting [On] | Letterhead Setting [Off] |
| 1-sided print ☞ | | | | |
| 2-sided print ☞ | | | | |
| 1-sided print ☞ | | | | |
| 2-sided print ☞ | | | | |

6

To make sure documents are printed correctly, follow the procedure to configure the print settings.

1. Press the [Menu] key.

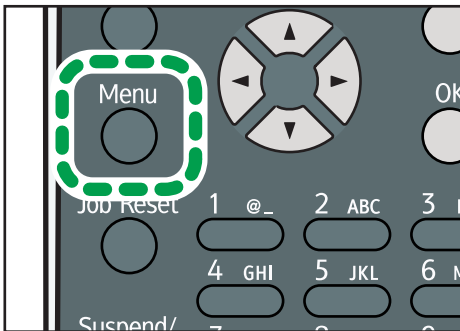

CEC216

2. Press the [▼] or [▲] key to select [Print Settings], and then press the [OK] key.

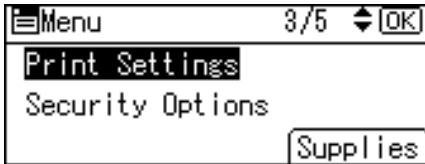

3. Press the [▼] or [▲] key to select [Machine Modes], and then press the [OK] key.

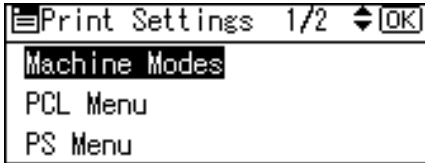

4. Press the [▼] or [▲] key to select [Letterhead Setting], and then press the [OK] key.

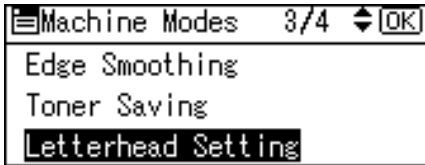

5. Select one of the following settings, and then press the [OK] key.

| | |
|-------------|--|
| On (Always) | The printer always prints on paper that has a fixed orientation |
| Auto Detect | The printer will print on paper that has a fixed orientation only if [Letterhead] or [Preprinted] is specified as the paper type in the printer driver's settings. |
| Off | The printer will print on paper in a fixed orientation, regardless of the specified paper type or the printer driver's settings. |

6. Press the [Menu] key to return to the initial screen.

Registering Unique Names to Paper Types

You can register a unique name to a paper type using Web Image Monitor. The name you register should reflect the paper's type or usage, as this will make recognizing the paper type easier.

★ Important

- This function can be used when the printer is operating in a network, and bidirectional communication is enabled.
- This function cannot be used with the printer driver's [Manage Preset List...] function.
- The printer's logs do not record names of user paper types.

Registering Names to Paper Types

★ Important

- The printer driver might not display the paper type name correctly if it is registered using an unsupported language.
- The control panel might not display the paper type name correctly if it is registered using non-alphanumeric characters (i.e., other than a-z, A-Z, or 0-9).

1. Log in to Web Image Monitor as an administrator.
2. Click [Configuration].
3. Click [User Paper Type] in the [Device Settings] area, and then change the settings as necessary.

The screen for selecting [User Paper Type] appears.

4. Enter a descriptive name for easier recognition in Paper Name.
5. Select a suitable paper type from the Paper Type list.
6. Click [OK].
7. Click [Logout].
8. Quit the Web Image Monitor.

↓ Note

- You can register up to eight user paper types.

Setting User Paper Types to Trays

Before printing, set the paper registered on the user paper type to the paper tray, and then set the paper type already registered. Paper types can be set either from Web Image Monitor or from the printer's control panel.

1. Log in to Web Image Monitor as an administrator.
2. Click [Configuration].
3. Click [Paper] in the [Device Settings] area.
4. Set the paper tray you want to use as a user paper type, and then select the registered paper type.
5. Click [OK].
6. Click [Logout].
7. Quit the Web Image Monitor.

Printing Using Registered Paper Types

1. Select your application's print command.
2. On the tab in the properties dialog box that appears, select a registered paper type under [Paper Type:].
3. Execute the print command.

The preregistered settings are applied and print is performed.

Note

- For details about printer driver settings, see the printer driver Help.

7. Maintaining the Printer

This chapter explains how to replace consumables, and clean the printer.

Replacing the Print Cartridge

WARNING

- Do not incinerate toner (new or used) or toner containers. Doing so risks burns. Toner will ignite on contact with naked flame.

WARNING

- Keep the polythene materials (bags, gloves, etc.) supplied with this machine away from babies and small children at all times. Suffocation can result if polythene materials are brought into contact with the mouth or nose.

CAUTION

- Store toner (new or used), toner containers, and components that have been in contact with toner out of reach of children.

CAUTION

- If toner or used toner is inhaled, gargle with plenty of water and move into a fresh air environment. Consult a doctor if necessary.

CAUTION

- If toner or used toner gets into your eyes, flush immediately with large amounts of water. Consult a doctor if necessary.

CAUTION

- If toner or used toner is swallowed, dilute by drinking a large amount of water. Consult a doctor if necessary.

CAUTION

- When removing jammed paper or replacing toner, avoid getting toner (new or used) on your clothing. If toner comes into contact with your clothing, wash the stained area with cold water. Hot water will set the toner into the fabric and make removing the stain impossible.

CAUTION

- When removing jammed paper or replacing toner, avoid getting toner (new or used) on your skin. If toner comes into contact with your skin, wash the affected area thoroughly with soap and water.

Important

- Actual printable numbers vary depending on image volume and density, number of pages printed at a time, paper type and size, and environmental conditions such as temperature and humidity. Toner quality degrades over time. Early replacement of the print cartridge might be necessary. Therefore, we recommend you always keep a new print cartridge ready.
- The print cartridge might need to be replaced even if there is toner remaining in it. This is due to depletion or wear of other components.
- Do not shake or shock the print cartridge.
- Do not allow paper clips, staples, or other small metallic objects to fall inside the printer.
- Do not expose the print cartridge without its cover to direct sunlight for a long time.
- When removing print cartridge, be careful not to drop it.
- Store print cartridges in a cool dark place.

Note

- If print cartridge are not changed when necessary, printing will become impossible. We recommend keeping a stock of print cartridge.
- Print cartridge (consumables) are not covered by warranty. However, if there is problem, contact the store where they were purchased.

Replace the print cartridge if the following message appears on the display:

"Replace print cartridge."

- This message appears when the toner has run out.
"Replace print cartridge. /Print Cartridge replacement is required.(Out of toner)"

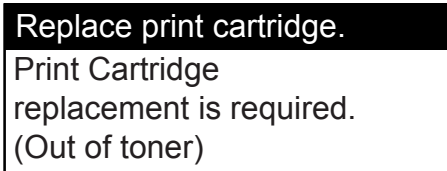

Replace print cartridge.
Print Cartridge
replacement is required.
(Out of toner)

CEE107

- This message appears when the waste toner bottle is full.
"Replace print cartridge. /Print Cartridge replacement is required.(Waste Toner Bottle full)"

| |
|--|
| Replace print cartridge. |
| Print Cartridge replacement is required. (Waste Toner Bottle full) |

CEE108

When the following message appears on the display, the print cartridge should be replaced soon. Prepare a new print cartridge.

"Replace print cartrdg soon."

| |
|--|
| Replace print cartrdg soon. |
| Toner is almost empty. Contact your local vendor. |
| Option Prt. Jobs Supplies |

CEE109

| |
|--|
| Replace print cartrdg soon. |
| Component at end of life. Replace if blurred/streaked |
| Option Prt. Jobs Supplies |

CEE133

The print cartridge must be replaced when the life of the photoconductor unit is ending.

When the printer detects this condition, it will display the following message on the control panel.

"Prepare Replacement"

| |
|--|
| Prepare Replacement |
| Check print cartridge replacement(s). |
| Option Prt. Jobs Supplies |

CEE134

1. Open the front cover by pushing the front cover release button.

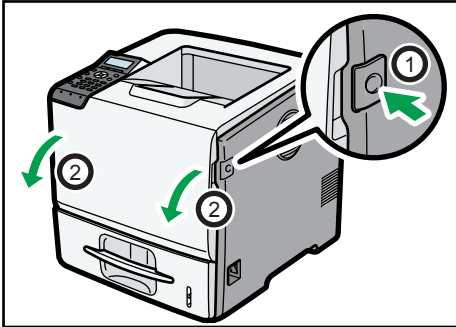

CEC025

2. Pull the print cartridge out of the printer by holding the grips of the cartridge.

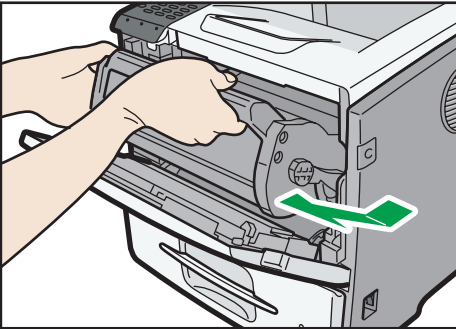

CEC026

3. Be sure to put the print cartridge on a stable, flat surface.
4. Wipe around the metallic registration roller by turning with a soft damp cloth.

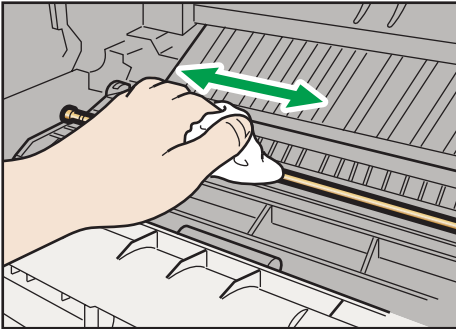

CEC040

5. Take the new print cartridge from the box.

6. Hold the grips of the cartridge, and then insert it into the printer until it stops.

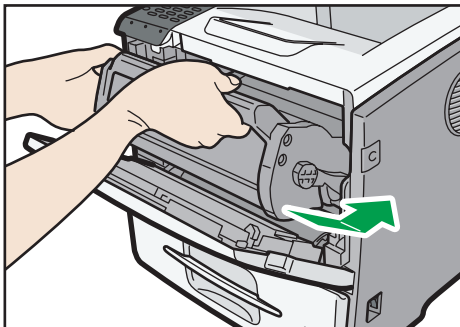

CEC028

7. Close the front cover.

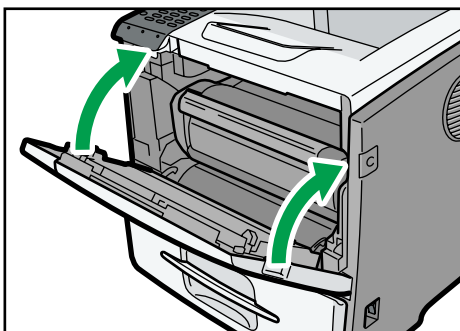

CEC214

Note

- Do not close the front cover with excessive force. If you cannot close the cover easily, pull out the print cartridge from the printer and reinsert it again. After that, close the front cover again.

Replacing the Maintenance Kit

Refer to the maintenance guide provided with the new items for the replacement maintenance kit.

CAUTION

- The inside of the machine could be very hot. Do not touch the parts with a label indicating the "hot surface". Otherwise, an injury might occur.
- Grip the plug, not the cord, when pulling the plug from the socket. Pulling the cord causes wear and tear that can result in fire or electric shock.
- Wait at least one hour after power off before replacing parts. Not allowing the printer to cool may result in burns.

When to replace the Maintenance Kit.

The maintenance kit contains parts for maintaining the printer.

Replace the maintenance kit if the following message appears on the display:

"Replacmnt Requird:Maint. Kit"

7

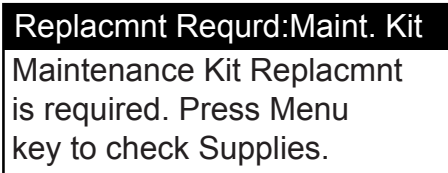

CEE120

When the following message appears on the display, the maintenance kit contains parts should be replaced soon. Prepare a new maintenance kit.

"Repl Requird Soon:Maint. Kit"

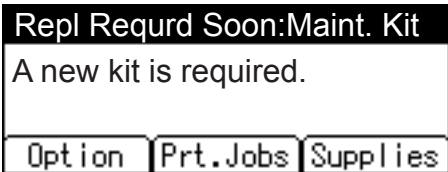

CEE119

Cautions When Cleaning

WARNING

- Do not remove any covers or screws other than those explicitly mentioned in this manual. Inside this machine are high voltage components that are an electric shock hazard and laser components that could cause blindness. Contact your sales or service representative if any of the machine's internal components require maintenance, adjustment, or repair.
- Do not attempt to disassemble or modify this machine. Doing so risks burns and electric shock. Note again that exposure to the laser components inside this machine risks blindness.

CAUTION

- The inside of the machine could be very hot. Do not touch the parts with a label indicating the "hot surface". Otherwise, an injury might occur.

CAUTION

- Be sure to disconnect the plug from the wall outlet and clean the prongs and the area around the prongs at least once a year. Allowing dust to build up on the plug constitutes a fire hazard.

CAUTION

- If the machine's interior is not cleaned regularly, dust will accumulate. Fire and breakdown can result from heavy accumulation of dust inside this machine. Contact your sales or service representative for details about and charges for cleaning the machine's interior.

Clean the printer periodically to maintain fine printing.

Dry wipe the exterior with a soft cloth. If dry wiping is not enough, wipe with a soft, wet cloth that is wrung out well. If you still cannot remove the stain or dirt, apply a neutral detergent, and then wipe over with a well-wrung wet cloth, dry wipe, and then let it dry.

Important

- To avoid deformation, discoloration, or cracking, do not use volatile chemicals, such as benzene and thinner, or spray insecticide on the printer.
- If there is dust or grime inside the printer, wipe with a clean, dry cloth.
- You must disconnect the plug from the wall outlet at least once a year. Clean away any dust and grime from the plug and outlet before reconnecting. Accumulated dust and grime pose a fire hazard.
- Do not allow paper clips, staples, or other small metallic objects to fall inside the printer.

Cleaning the Friction Pad and the Paper Feed Roller

If the friction pad or paper feed roller is dirty, a multi-feed or misfeed might occur.

In this case, clean the friction pad and paper feed roller as follows:

CAUTION

- When moving the machine, hold the inset grips at both sides, and then lift the printer slowly. Lifting it carelessly or dropping it may cause an injury.

CAUTION

- When performing maintenance on the machine, always disconnect the power cord from the wall outlet.

CAUTION

- When disconnecting the power cord from the wall outlet, always pull the plug, not the cord. Pulling the cord can damage the power cord. Use of damaged power cords could result in fire or electric shock.

7

CAUTION

- Do not pull out the paper tray forcefully. If you do, the tray might fall and cause an injury.

CAUTION

- Do not put your hands inside the printer when the input tray is removed. Some internal parts become hot and are a burn hazard.

Important

- Do not use chemical cleaners or organic solvents such as thinners or benzene.
1. Turn off the power switch.
 2. Pull out the plug from the socket. Remove all the cables from the printer.

3. Lift and pull Tray 1 carefully, and then pull it out with both hands.

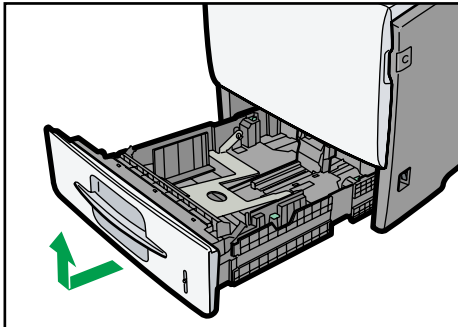

CEC031

Place the tray on a flat surface. When there is paper in the tray, remove paper.

4. Wipe the friction pad with a damp cloth.

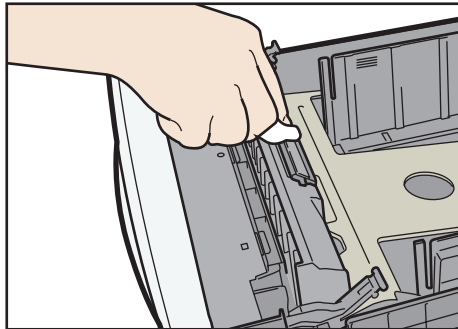

CEC041

5. Wipe the rubber part of the roller with a soft damp cloth. After that, wipe it with a dry cloth to remove the water.

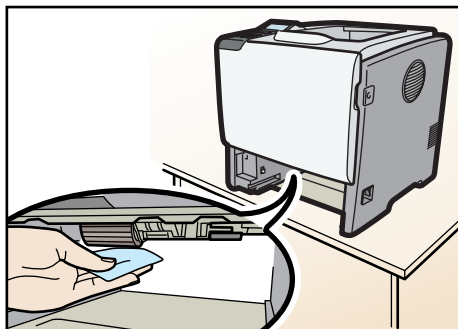

CEC078

6. Slide Tray 1 along the rails, and push it carefully all the way into the printer.

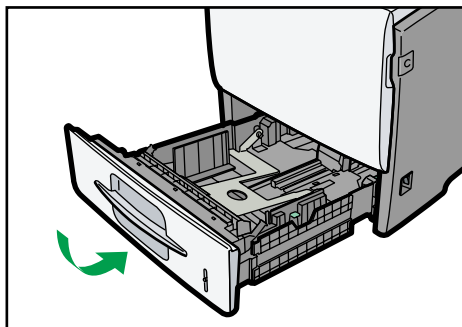

CEC240

Do not slide the paper tray in with force. If you do, the front and side guides might move.

7. Insert the plug of the power cord into the wall socket securely. Connect all the interface cables that were removed.
8. Turn the power switch on.

Note

- If misfeeds or multi-feeds of paper occur after cleaning the friction pad and paper feed roller, contact your sales or service representative.
- If the optional paper feed unit is installed, clean its friction pad and paper feed roller in the same way as those of the main paper feed unit.

Cleaning the Registration Roller

If the registration roller is dirty, a misfeed might occur. In this case, clean the roller as follows:

⚠ WARNING

- Be sure to turn off the power switch and wait for about 15 minutes before cleaning the Registration roller. Not waiting for the printer to cool down can result in a burn.

⚠ CAUTION

- The inside of the machine could be very hot. Do not touch the parts with a label indicating the "hot surface". Otherwise, an injury might occur.

Clean the registration roller if dots (caused by specks of paper stuck to the roller) appear on printed OHP transparencies.

★ Important

- Do not hold the print cartridge upside down or stand it vertically.
 - Do not put the print cartridge on an unstable or tilted surface.
 - Do not use chemical cleaners or organic solvents such as thinners or benzene.
1. Turn off the power, and then unplug the power cable.
 2. Open the front cover by pushing the front cover release button.

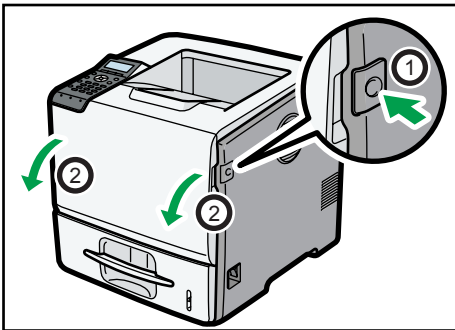

CEC025

- 3. Pull the print cartridge out of the printer by holding the grips of the cartridge.

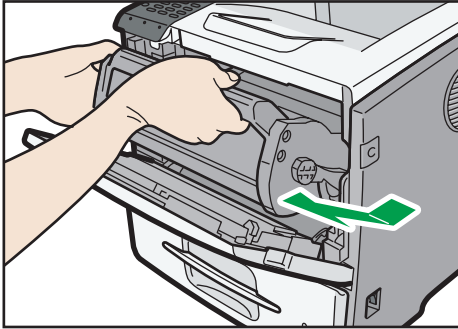

CEC026

- 4. Wipe around the metallic registration roller by turning with a soft damp cloth.

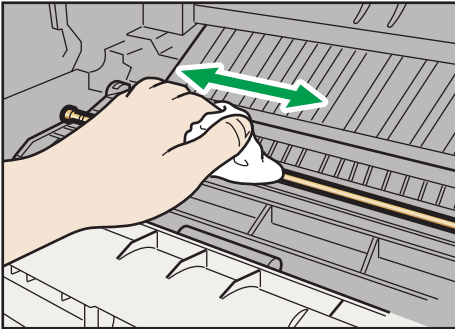

CEC040

- 5. Holding the grips of the print cartridge, push it into the printer until it stops.

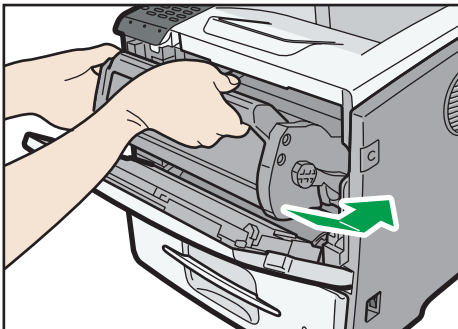

CEC028

6. Close the front cover.

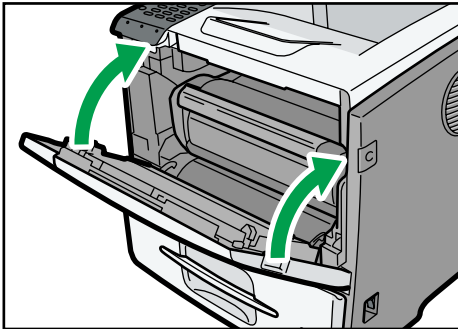

CEC214

Note

- Carefully close the front cover. If you cannot close the cover easily, pull the print cartridge out of the printer and insert it again. After that, close the front cover again.

8. Adjusting the Printer

This chapter explains how to adjust the image density and print position.

Adjusting the Image Density

★ Important

- Maximized settings may produce smudged printouts.
- Image Density settings should be made from the application or the printer driver whenever possible.

1. Press the [Menu] key.

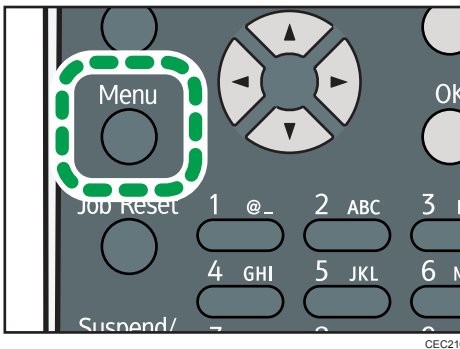

2. Press the [▼] or [▲] key to select [Maintenance], and then press the [OK] key.

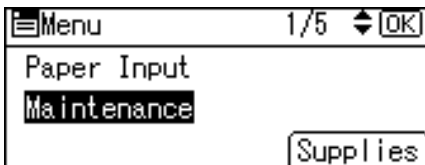

3. Press the [▼] or [▲] key to select [Quality Maintenance], and then press the [OK] key.

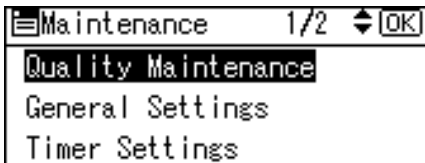

4. Press the [▼] or [▲] key to select [Image Density Adjustment], and then press the [OK] key.

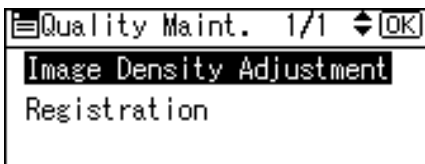

5. Press the [▼] or [▲] key to specify the image density, and then press the [OK] key.

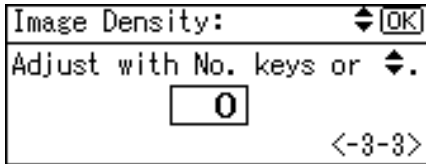

You can specify the image density in the range from -3 to +3.

6. Press the [Menu] key.

Note

- To maintain a darker image under high volume printing conditions, Selecting 3 from the control panel is highly recommended.
- You can adjust the image density in seven steps from -3 to +3. Increasing the value makes the printouts darker and decreasing the value makes the printouts lighter.

Adjusting Printing Position

You can adjust the printing position for each tray. "Horizontal" means perpendicular to the feed direction. "Vertical" means it's parallel to the paper feed direction. Normally you do not need to update the printing position. However, updating is useful in some cases when the optional paper feed unit is installed.

1. Press the [Menu] key.

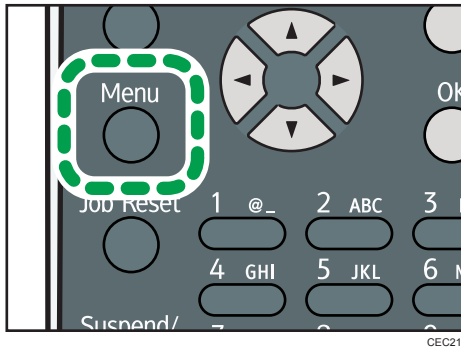

2. Press the [▼] or [▲] key to select [Maintenance], and then press the [OK] key.

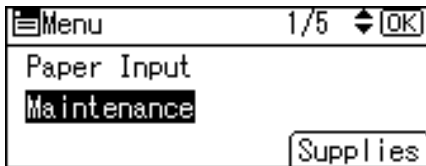

3. Press the [▼] or [▲] key to select [Quality Maintenance], and then press the [OK] key.

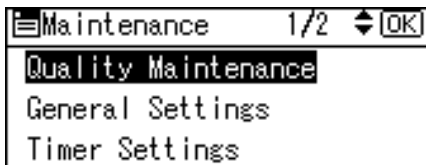

4. Press the [▼] or [▲] key to select [Registration], and then press the [OK] key.

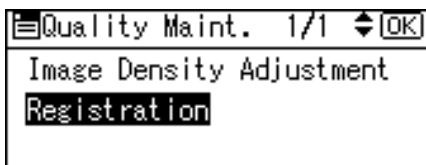

- 5. Press the [▼] or [▲] key to select [Print Test Sheet], and then press the [OK] key.

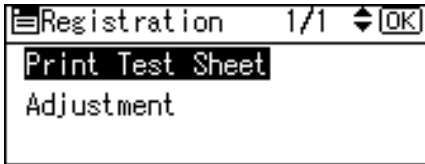

- 6. Press the [▼] or [▲] key to select the tray you want to adjust, and then press the [OK] key.
- 7. Confirm the position of the image on the test sheet, and then adjust the registration value.

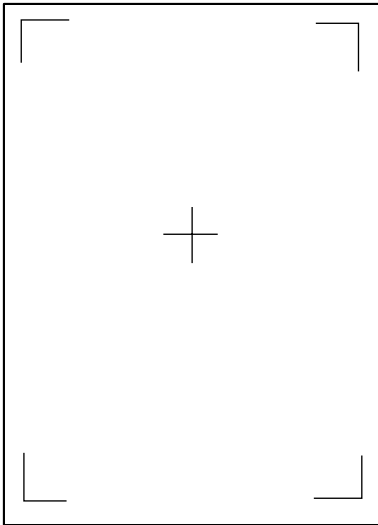

8

Use this sheet to confirm the current print position.

- 8. Press the [Escape] key until the screen returns to the [Registration] menu.
- 9. Press the [▼] or [▲] key to select [Adjustment], and then press the [OK] key.

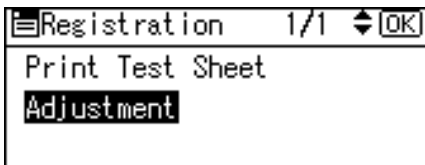

- 10. Press the [▼] or [▲] key to select the parameter you want to adjust, and then press the [OK] key.

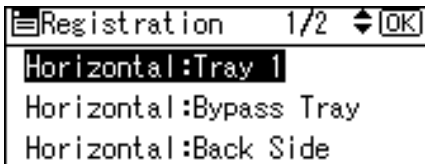

11. Enter the value (mm), and then press the [OK] key.

```

Reg.:Horiz.:Tray 1:  ⬆️⬆️ [OK]
Adjust with No. keys or ⬆️⬆️.
  0.0
<-5.0to5.0 by 0.1>
  
```

Increase the value to shift the print area in the direction indicated by the "+" symbol in the diagram below. Decrease the value to shift the print area in the direction indicated by the "-" symbol.

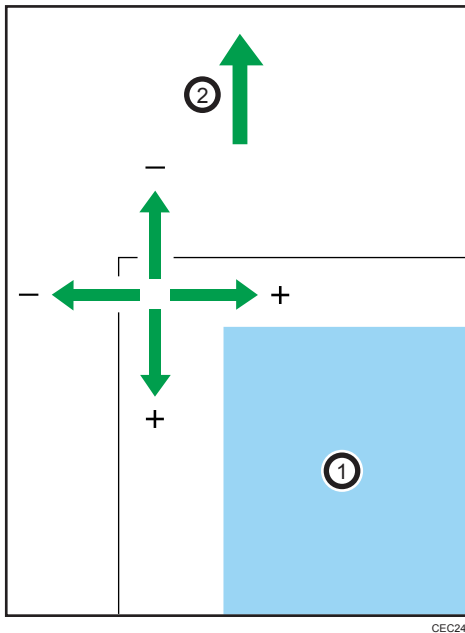

- ①: Print Area
 ②: Paper Feed Direction

Pressing the [▼] or [▲] key adjusts the value up or down in 0.1 mm increments.

12. Press the [OK] key to return to the [Registration] menu.
 13. Print the test sheet to confirm the adjustment result.
 14. Press the [Menu] key to return to the initial screen.

Adjusting the Paper Type

1. Press the [Menu] key.

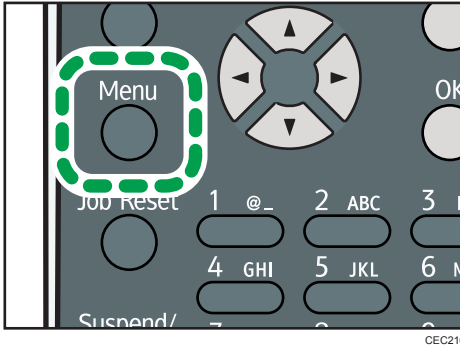

2. Press the [▼] or [▲] key to select [Maintenance], and then press the [OK] key.

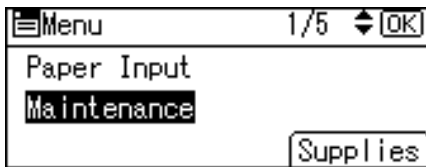

3. Press the [▼] or [▲] key to select [General Settings], and then press the [OK] key.

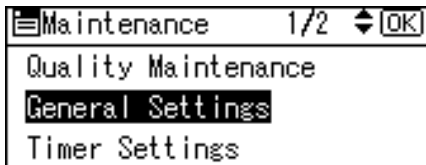

4. Press the [▼] or [▲] key to select the paper type you want to use, and then press the [OK] key.

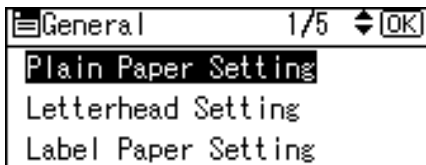

The following paper types are selectable:

Plain Paper, Letterhead, Label Paper, Envelope.

5. If you have selected the [Plain Paper Setting], select the tray you want to set using the [▼] or [▲] key, and then press the [OK] key.

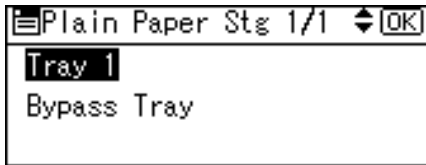

6. Press the [▼] or [▲] key to select the paper setting, and then press the [OK] key.

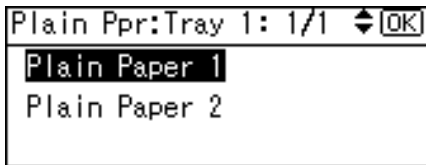

7. Press the [Menu] key to return to the initial screen.

9. Troubleshooting

This chapter provides solutions to common problems and it also explains how to correct unwanted print results.

Error and Status Messages Appear on the Control Panel

This section explains what the messages that appear on the control panel mean and what to do when a particular message appears.

Status Messages (in alphabetical order)

@Remote Certif. updating...

The printer is updating the @Remote certificate.

Energy Saver Mode

The printer is in Energy Saver mode. Press any key to recover to the normal mode.

Hex Dump Mode

In Hex Dump mode, the printer receives data in hexadecimal format. Turn off the printer after printing, and then turn back on.

Job Suspended

All jobs are suspended. Turn off the printer, and turn it on again to recover.

Offline

The printer is offline and cannot print.

Please wait...

This message may appear for a few seconds. It means the printer is initializing, replenishing toner, or executing maintenance operations. Wait a while.

Printing...

The printer is printing. Wait a while.

Printing Suspended

Printing is suspended. To resume printing, press the [Suspend/Resume] key.

Ready

This is the default ready message. The printer is ready for use. No action is required.

Resetting Job...

The printer is resetting the print job. Wait a while.

Setting change...

The printer is applying the changes made to its settings. Wait a while.

Waiting for print data...

The printer is waiting for the next data to print. Wait a while.

Alert Messages (in alphabetical order)

Ⓜ(A) Remove misfeed in Trays. Opn & cls Frt. Cov.

Remove the jammed paper in the source tray, and then load the paper again. To reset the error, open the front cover and then close it. For details, see p.193 "Paper Misfeed Message (A)".

Ⓜ(B)(C) Open Front/Rear Cover and remove misfeed.

Open the front or rear cover, and then remove the jammed paper. For details, see p.197 "Paper Misfeed Message (B)(C)".

Ⓜ(Y1) Remove misfeed in Tray 2. Opn & cls Frt. Cov.

Remove the jammed paper in the source tray, and then load the paper again. To reset the error, open the front cover and then close it. For details, see p.202 "Paper Misfeed Message (Y1)(Y2)(Y3)(Y4)".

Ⓜ(Y2) Remove misfeed in Tray 3. Opn & cls Frt. Cov.

Remove the jammed paper in the source tray, and then load the paper again. To reset the error, open the front cover and then close it. For details, see p.202 "Paper Misfeed Message (Y1)(Y2)(Y3)(Y4)".

Ⓜ(Y3) Remove misfeed in Tray 4. Opn & cls Frt. Cov.

Remove the jammed paper in the source tray, and then load the paper again. To reset the error, open the front cover and then close it. For details, see p.202 "Paper Misfeed Message (Y1)(Y2)(Y3)(Y4)".

Ⓜ(Y4) Remove misfeed in Tray 5. Opn & cls Frt. Cov.

Remove the jammed paper in the source tray, and then load the paper again. To reset the error, open the front cover and then close it. For details, see p.202 "Paper Misfeed Message (Y1)(Y2)(Y3)(Y4)".

Ⓜ(Z1)(Z2) Opn R.Cov/Tray1 & remove ppr. Opn & cls F.Cov

Open the rear cover, or remove tray 1 and open the front cover, and then remove the paper. For details, see p.205 "Paper Misfeed Message (Z1)(Z2)".

@Remote Cert. update failed

Updating the @Remote certificate failed. Contact your sales or service representative.

Cannot connect=>Comm.Serv. Check proxy user/password.

The proxy user name or password is incorrect. Check the proxy server settings, and change the user name and/or password if they are incorrect.

Cannot connect with DHCP server.(101/201)

Cannot obtain IP address from DHCP server. Consult your network administrator.

Cannot connect with NetWare print server. (107/207)

Connection with NetWare print server is unavailable.

Cannot connect with NetWare server.(106/206)

Connection with NetWare server is unavailable. Consult your network administrator.

Cannot print.

Check the file you want to print is a supported file type. Check for misfeeds and ask your network administrator for help.

Check network settings.(103/203)

The IP address setting is incorrect. Check the IP address, subnet mask, and gateway address. For details, see p.75 "Ethernet Configuration".

Classification Code Error

A classification code is not specified for the print job. Enter a classification code using the printer properties and print the document again.

For details, see "Registering Classification Codes", Software Guide.

Connect failed:WirelessCard Turn power off, check card.

Check there is a Wireless LAN board installed.

Check that it is a supported board. If it is, check it is installed correctly.

Install the correct board properly. For details, see p.59 "Installing the Interface Units".

Cover Open. Please close the indicated cover.

Close the cover indicated on the control panel.

Duplex mode is in off position for (tray name)

The duplex mode for the indicated tray is off; you can only use one-sided printing. Press [Change] to change the tray's settings, press [JobReset] to reset the job, or press [Form Feed] to force printing.

Ethernet Board Error

An error on the Ethernet board is detected. Pull out and then re-install the controller board. If the problem persists, contact your sales or service representative.

Failed to connect to server for Remote Diagnostics.

The printer cannot communicate with Remote Communication Gate. Check the connection to the Remote Server Gate.

Independent-supply toner

Independent-supply toner is set. Use toner recommended for this printer.

IPDS font error. Turn power switch off then on. Select Reset IPDS Fonts in Maintenance.

IPDS font error has occurred. Perform the shutdown procedure, and then turn off the power of the machine. Turn on the power again, and then execute [Reset IPDS Fonts].

IPv6 Address already exists Link-local Address(109/209)

The same IPv6 address already exists. Consult your network administrator.

IPv6 Address already exists Stateless Address(109/209)

The same IPv6 address already exists. Consult your network administrator.

IPv6 Address already exists Manual Config. Address(109/209)

The same IPv6 address already exists. Consult your network administrator.

Load paper in (tray name) or [Cancel] to FormFeed.

There is no paper in the specified tray. Load the specified paper in the tray, press [JobReset] to reset the job.

Option RAM Error

The printer cannot detect an optional SDRAM module. It may be incorrectly installed.

Check if it is installed properly.

For details about installing the unit, see p.52 "Installing the Memory Expansion Units".

Output tray is full.

The output trays are full. Remove the paper.

Parallel I/F Error

The printer's self diagnostic test failed due to a loopback error. Replace the IEEE 1284 board that caused the error. For details, see p.59 "Installing the Interface Units".

Prepare Replacement Check print cartridge replacement(s).

The toner has run out, or the photo conductor unit has reached the end of its service life. Prepare a new print cartridge.

Printer Font Error.

There are problems with the printer's font file.

Contact your sales or service representative.

Problem with Hard Disk Please call service.

The printer cannot detect a hard disk. It may be incorrectly installed.

Check if it is installed properly or contact your sales or service representative.

For details about installing the unit, see p.52 "Installing the Memory Expansion Units".

Problem:Wireless card Please call service.

The printer cannot detect a Wireless LAN board. It may be incorrectly installed.

Check if it is installed properly or contact your sales or service representative.

For details about installing the unit, see p.59 "Installing the Interface Units".

Repl Requird Soon:Maint. Kit

You will need to replace the maintenance kit soon. Contact your sales or service representative to obtain a new maintenance kit. For details, see p.154 "Replacing the Maintenance Kit".

Replace print cartridge. /Print Cartridge replacement is required.(Out of toner)

The toner has run out. Replace the print cartridge. For details, see p.149 "Replacing the Print Cartridge".

Replace print cartridge. /Print Cartridge replacement is required.(Waste Toner Bottle full)

The waste toner bottle is full. Replace the print cartridge. For details, see p.149 "Replacing the Print Cartridge".

Replacmnt Requird:Maint. Kit / Maintenance Kit Replacmnt is required. Press Menu key to check Supplies.

You need to replace the Maintenance Kit. Contact your sales or service representative to obtain a new unit. For details, see p.154 "Replacing the Maintenance Kit".

Replace print cartrdg soon./ Component at end of life. Replace if blurred/streaked

Some parts inside the print cartridge have reached their end of life. Contact your sales or service representative to obtain a new print cartridge.

Replace print cartrdg soon./ Toner is almost empty. Contact your local vendor.

The toner is almost depleted. Contact your sales or service representative to obtain a new print cartridge.

SD Card authenticatn.failed Error recurs, call service.

Authentication from the SD card failed. Turn the power off, and then back on. If the error recurs, contact your sales or service representative.

Set the Fusing Unit correctly.

The fusing unit may not be installed correctly. Turn the printer off and re-install the fusing unit.

If the message is still displayed after re-installation, contact your sales or service representative.

For details, see the procedure for removing the Fusing unit in p.197 "Paper Misfeed Message (B)(C)" or the unit replacement procedure manual provided with the Fusing unit.

Set the Print Cartridge correctly.

The print cartridge may not be installed correctly. Turn the printer off and re-install the Print cartridge. If the message is still displayed after re-installation, contact your sales or service representative. For details, see p.149 "Replacing the Print Cartridge".

Supply order has failed.

The automatic supply order failed. The message indicates the supplies that the printer tried to order.

This NetBIOS name is already in use.(108/208)

The NetBIOS name specified for the printer is already in use by another device on the network. Consult your network administrator.

The same IPv4 Address already exists.(102/202)

The IPv4 address specified for the printer is already in use by another device on the network. Consult your network administrator.

The selected job has already been printed or deleted.

This message might appear if you print or delete a job from Web Image Monitor. Press Exit on the message screen.

USB has a problem. Please call service.

The printer has detected a USB board failure. Turn the power off, and then on again. If the problem persists, contact your sales or service representative.

Values set for IPv6/Gateway addresses are invalid.(110/210)

The IPv6 address or gateway address is invalid. Check the network settings.

WPA Auth. incomplete.(211)

WPA authentication could not complete. Consult your network administrator.

Note

- Confirm error details by printing the Error Log. For details, see p.44 "Test Printing".

Panel Tones

The following table explains the meaning of the various tone patterns that the printer emits to alerts users about its condition.

| Tone pattern | Meaning | Cause |
|---------------------------------------|------------------------------|--|
| Two long beeps. | Printer ready. | After cooling or being switched on, the printer has fully warmed up and is ready for use. |
| Single short beep. | Panel/screen input accepted. | A valid control panel or screen key was pressed. Single short beeps are produced only when valid keys are pressed. |
| Single long beep. | Job completed. | A Printer job has finished. |
| Four long beeps. | Printer initialized. | The screen is changing back to the initial screen after the printer came out of the energy-saving mode or was reset. |
| Five short beeps repeated five times. | Printer alert. | Printer requires user attention. Paper may have jammed or print cartridge may need replenishing. |

↓ Note

- Users cannot mute the printer's tone alerts. When the printer beeps to alert users of a paper jam or toner request, if the printer's covers are opened and closed repeatedly within a short space of time, the tone alert might continue, even after normal status has resumed.

Printer Does Not Print

Is the power on?

Confirm that the cable is securely plugged into both the power outlet and the printer.
Turn on the power.

Does the Alert indicator stay red?

If so, check the error message on the display and take the required action.
For details, see p.171 "Error and Status Messages Appear on the Control Panel".

Is paper loaded?

Load paper into the paper tray or onto the bypass tray.
For details, see p.101 "Supported Paper for Each Tray".

Can you print a configuration page?

If you cannot print a configuration page, it probably indicates a printer malfunction. Contact your sales or service representative.
For details, see p.44 "Test Printing".

Is the interface cable connected securely to the printer and the computer?

Connect the interface cable securely. If it has a fastener, fasten it securely as well.

Are you using the correct interface cable?

The type of interface cable you should use depends on the computer you use. Be sure to use the correct one.

If the cable is damaged or worn, replace it with a new one.
For details, see p.213 "Specifications".

Is the Data In indicator blinking or lit after starting a print job?

If not blinking or lit, the data is not being sent to the printer.

- If the printer is connected to the computer using the interface cable
Check the port connection setting is correct. For details about checking the port connection, see p.179 "Checking the Port Connection".
- Network Connection
Consult your network administrator.

How is the signal strength when using the Wireless LAN?

- 802.11 Ad hoc Mode
Either move to a location where the signal is good, or remove obstructions.

- Infrastructure Mode

Check the signal status in the [Wireless LAN] menu on the control panel. If the signal is poor, either move to a location where it is good, or remove obstructions.

Checking the Port Connection

When the Data in indicator does not flash or light up, check the port connection as shown below to confirm the setting.

- For a parallel port connection, the port must be set to LPT 1 or LPT 2.
 - For a USB port connection, the port must be set to USB00(n)*.
- * (n) varies depending on the number of printers connected.

Windows

Windows XP Professional or Windows Server 2003/2003 R2

1. Click the [Start] button, and then click [Printers and Faxes].
2. Click the icon of the printer. On the [File] menu, click [Properties].
3. Click the [Ports] tab.
4. In the [Print to the following port(s)] list, confirm the correct port is selected.

Windows XP Home Edition

1. Click the [Start] button, and then click [Control Panel].
2. Click [Printers and Other Hardware].
3. Click [Printers and Faxes].
4. Click the icon of the printer. On the [File] menu, click [Properties].
5. Click the [Ports] tab.
6. In the [Print to the following port(s)] list, confirm the correct port is selected.

Windows Vista or Windows Server 2008

1. Click the [Start] button, and then click [Control Panel].
2. Click [Printer].
3. Click the icon of the printer. On the [File] menu, click [Properties].
4. Click the [Ports] tab.
5. In the [Print to the following port(s)] list, confirm the correct port is selected.

Windows 7 or Windows Server 2008 R2

1. Click the [Start] button, and then click [Devices and Printers].
2. Right-click the printer icon you want to check, and then click [Printer Properties].
3. Click the [Ports] tab.
4. In the [Print to the following port(s)] list, confirm the correct port is selected.

Mac OS X

When the printer is connected to Mac OS X and the Ready indicator does not flash or light up, try the following procedures to check the port connection.

- Use [About This Mac] to check the USB information.
- Use the printer browser to check if the printer is displayed.

Using [About This Mac]

1. Click Apple Menu, and then select [About This Mac].
2. Click [More Info].
3. Under [Contents], for [Hardware], Select [USB].

Using the printer browser

1. Start [Printer Setup Utility] or [Printer Center] utility.

Under Mac OS X 10.5 or 10.6, start System Preferences and click [Print & Fax].

2. Click [Add] or [+] button.

The printer browser starts.

Confirm the printer is displayed on the browser.

Other Printing Problems

When You Cannot Print Properly

Toner smears appear on the print side of the page.

- The paper setting may not be correct. For example, you are using thick paper but the setting for thick paper might not be set.
- Check the paper settings.
- Check the printer driver's paper settings. See the printer driver Help.
- Check that the paper is not curled or bent. Envelopes can easily become curled. For details, see p.105 "Supported Paper Types".

Photo images are coarse.

- Some applications lower the resolution for making prints.
Raise the resolution in the settings of the application.

Fine dot patterns do not print.

- Change the [Dithering:] setting in the PostScript 3 printer driver's dialog box.
For details, see the printer driver Help.

Solid lines are printed as broken lines.

- Change the [Dithering:] setting in the PostScript 3 printer driver's dialog box.
For details, see the printer driver Help.

The whole printout is blurred.

- The paper is damp, probably due to improper storage. Use dry paper that has been stored properly.
For details, see p.105 "Supported Paper Types".
- Toner is almost depleted. When the "Replace print cartridge." message appears on the display, replace the print cartridge. For details, see p.149 "Replacing the Print Cartridge".
- Condensation may have collected. If rapid change in temperature or humidity occurs, use this printer only after it has acclimatized.

White streaks or color streaks appear.

- Toner is almost depleted. When the "Replace print cartridge." message appears on the display, replace the print cartridge. For details, see p.149 "Replacing the Print Cartridge".

Images are not printed in the right position.



- Adjust the printing position.

Adjust the printing position for each tray by specifying the adjustment values for [Registration] in [Quality Maintenance] under [Maintenance] using the control panel. For details, see p. 165 "Adjusting Printing Position".

- Adjust the end guide and both side paper guides to match the paper size. See p. 117 "Loading Paper in Trays".

Images are printed at an angle.



- Adjust the end guide and both side paper guides to match the paper size. See p. 117 "Loading Paper in Trays".

White lines appear.

Toner is almost depleted. When the "Replace print cartridge." message appears on the display, replace the print cartridge. For details, see p. 149 "Replacing the Print Cartridge".



The backs of printed sheets are blemished.

- When removing a jammed sheet, the inside of the printer may have become dirtied. Print several sheets until they come out clean.
- If document size is larger than paper size, e.g. A4 document on B5 paper, the back of the next printed sheet may be dirtied.

If rubbed with your finger, it smears out.

- The setting of the paper may not be correct. For example, although thick paper is used, the setting for thick paper may not be set.
 - Check the paper settings of this printer.
For details, see p.105 "Supported Paper Types".
 - Check the paper settings of the printer driver.
For details, see the printer driver Help.
 - Check the envelope lever settings.
For details, see p.133 "Loading Envelopes".
- The fusing unit is deteriorated or damaged. Replace the unit.
For details, see p.154 "Replacing the Maintenance Kit".

When printing on OHP transparencies, black or white dots are obvious.

The registration roller is dirty. Clean the registration roller. Contact your sales/service representatives. Image quality varies when printing on thick paper or on OHP transparencies. Switch to Thick Paper mode. For details, see "Making Printer Settings Using the Control Panel", Software Guide.

When printing on plain paper, white dots are obvious.

- The registration roller or the paper tray is dirty. Clean the registration roller or the paper tray.
For details, see p.159 "Cleaning the Registration Roller".

Paper Misfeeds Occur Frequently

Paper jams occur frequently.

- Number of paper set in the tray exceeds the limit. Confirm that the top of the stack is not higher than the limit mark inside the tray.
For details, see p.101 "Supported Paper for Each Tray".
- There may be a gap between the front guide and the paper, or between the side guides and the paper in the paper tray. Make sure there are no gaps.
For details, see p.101 "Supported Paper for Each Tray".
- Paper is either too thick or too thin.

For details, see p.105 "Supported Paper Types".

- Paper is bent or wrinkled. Use paper that have no bents or wrinkles.

For details, see p.105 "Supported Paper Types".

- Paper has already been printed on.

For details, see p.105 "Supported Paper Types".

- Paper is damp. Use paper that has been stored properly.

For details, see p.105 "Supported Paper Types".

- When loading paper, separate paper from each other.

- The friction pad or paper feed roller or registration roller may be dirty. Clean the pertinent section as necessary. See p.156 "Cleaning the Friction Pad and the Paper Feed Roller" and p.159 "Cleaning the Registration Roller".

- The paper setting may not be correct. For example, although you are using thick paper, the setting for thick paper may not be set.

Check the printer driver's paper settings. See the printer driver Help.

Multiple pages are fed at once.

- There may be a gap between the end guide and the paper, or between the paper guides on both sides and the paper in the paper tray. Be sure to close any gaps by repositioning the guides. See p.117 "Loading Paper in Trays".

- Paper is either too thick or too thin.

For details, see p.105 "Supported Paper Types".

- Paper has already been printed on.

For details, see p.105 "Supported Paper Types".

- Number of paper set in the tray exceeds the limit. Confirm that the top of the stack is not higher than the limit mark inside the tray.

For details, see p.101 "Supported Paper for Each Tray".

- Paper is static. Use paper that has been stored properly.

For details, see p.105 "Supported Paper Types".

- When loading paper, separate paper from each other.

- The friction pad or paper feed roller may be dirty. Clean the pertinent section as necessary.

See p.156 "Cleaning the Friction Pad and the Paper Feed Roller".

- Check that paper has not been added while there is still some left in the tray.

Only add paper when there is none left in the tray.

Paper gets wrinkles.

- Paper is damp. Use paper that has been stored properly.

For details, see p.105 "Supported Paper Types".

- Paper is either too thick or too thin.

For details, see p.105 "Supported Paper Types".

- There may be a gap between the front guide and the paper, or between the side guides and the paper in the paper tray. Make sure there are no gaps.

For details, see p.101 "Supported Paper for Each Tray".

- The fusing unit is deteriorated or damaged. Replace the unit.

For details, see p.154 "Replacing the Maintenance Kit".

The printed image is different from the image on the computer

A printed image is different from the image on the computer's display.

- When you use some functions, such as enlargement or reduction, the layout of the image might be different from that displayed on the computer display.

Images are cut off, or excess pages are printed.

- If you are using paper smaller than the paper size selected in the application, use the same size paper as that selected in the application. If you cannot load paper of the correct size, use the reduction function to reduce the image, and then print.

For details, see the printer driver Help.

PDF Direct Print is not executed (PDF file is not printed).

- You must install an optional hard disk drive or set the value of [RAM Disk] in the System Menu to 2 MB or higher.

For details about [RAM Disk], see "System Menu", Software Guide.

- After adding a SDRAM module and setting the value of [RAM Disk] in the System Menu to 8 MB, value of [RAM Disk] returns to 0 MB if the SDRAM module is removed. If this happens, reset the value of [RAM Disk] to 2MB or higher.

For details about [RAM Disk], see "System Menu", Software Guide.

- When printing a PDF with a password set, set the password of the PDF file using the [Change PDF Password] menu in [PDF Menu] or Web Image Monitor. For details about [Change PDF Password], see "Print Settings Menu", Software Guide.

For details about Web Image Monitor, see Web Image Monitor Help.

- PDF files not allowed to be printed by the PDF file security setting cannot be printed.
- Highly compressed PDFs cannot be printed using PDF Direct Print.

Open the relevant application and print the PDF file using the printer driver.

Set the file format to standard PDF.

As a result of printing using PDF Direct Printing, characters are missing or misshapen.

- Before printing, embed the font in the PDF file to be printed.

The paper size appears on the control panel and printing is not performed with PDF Direct Print.

- When using PDF Direct Print, printout requires paper set within the PDF file. When a message indicating a paper size appears, either place the indicated size in the paper tray, or perform Form Feed.

Also, if [Sub Paper Size] in the [System] Menu is set to [Auto], printing is performed assuming letter size and A4 size to be the same size. For example, When a PDF file set to A4 size paper is printed using PDF Direct Print and letter size paper is loaded in the paper tray, the file will be printed out. This applies similarly to the opposite case.

When Printer is Not Functioning Properly

Paper is not fed from the selected tray.

- When you are using a Windows operating system, the printer driver settings override those set using the control panel. Set the desired input tray using the printer driver.

For details, see the printer driver Help.

Prints do not stack properly.

- Paper is damp. Use paper that has been stored properly.
See p.105 "Supported Paper Types".
- Pull out the extender.

It takes too much time to turn on the printer.

- If the printer is turned off while it is still accessing the hard disk (for example: during file deletion), the printer will require more time to power-up the next time it is turned on. To avoid this time delay, do not turn the power off while it is in operation.

It takes too much time to resume printing.

- The data is so large or complex that it takes time to process it. If the data in indicator is blinking, the data is being processed. Just wait until it resumes.
- The printer was in the Energy Saver mode. To resume from the Energy Saver mode, the printer has to warm up, and this takes time until printing starts. To disable the Energy Saver mode, select [Off] for [Auto Off On/Off] in the [System], [Auto Off] menu.

It takes too much time to complete the print job.

- Photographs and other data intensive pages take a long time for the printer to process, so simply wait when printing such data.

Changing the settings with printer driver may help to speed up printing.

For details, see the printer driver Help.

- The data is so large or complex that it takes time to process it. If the data in indicator is blinking, the data is being processed. Just wait until it resumes.
- If "Waiting for print data..." appears on the display, the printer is now warming up. Wait for a while.

Attached options are not detected in the printer properties.

- The computer and printer are not in two-way communication. You must configure attached options in the printer properties.

For details, see the printer driver Help.

If the problem cannot be solved, contact your sales or service representative.

When doing aggregate prints or bound prints.

- Check that the paper size and direction set in the printer driver are the same as those set in the application.

If the settings are not the same, change the settings of the printer driver.

An empty tray is selected by Auto Tray Select, and the document does not print out due to out of paper error.

- If a paper tray is opened and closed while the printer is in Energy Saver mode, the printer will initialize the tray upon recovery, but the tray will not be selectable by Auto Tray Select.

To print from a paper tray that you have opened and closed while the printer was in Energy Saver mode, you must manually specify the tray as the source paper tray before printing. When the printer recovers from Energy Saver mode and completes initialization, it will then print the document from the tray you have specified.

Additional Troubleshooting

Strange noise is heard.

- If a supply was recently replaced or an option attached in the area the strange noise is coming from, check the supply or option is properly attached. If the strange noise persists, contact your sales or service representative.

No e-mail is received when an Alert occurs, and after resolving an Alert.

- Confirm [Auto E-mail Notify] is active in the [System] Menu on the Control Panel. See "System Menu", Software Guide.
- Access the printer through a Web browser, log in as an Administrator on Web Image Monitor, and then confirm the following settings in [Auto E-mail Notification]:
 - Device E-mail Address
 - Groups to Notify
 - Select Groups/Items to Notify

For details about the settings, see Web Image Monitor Help.

- Access the printer through the Web browser, log in as an Administrator on the Web Image Monitor, and then confirm the settings of the SMTP server in [E-mail]. For details about the settings, see Web Image Monitor Help.
- When the power is turned off before the e-mail is transmitted, the e-mail will not be received.
- Check the e-mail address set for the destination. Confirm the printer's operation history using Web Image Monitor's System Log menu in [Network]. If the e-mail was sent but not received, it is possible the destination was incorrect. Also check the information concerning error mail from the e-mail server.

9

The setting for [Auto E-mail Notify] on the System Menu was changed from [Off] to [On], but e-mail is not arriving.

- After changing the setting, turn the printer's power off and then back on again.

Error notification e-mail was received, but no error-solved e-mail is received.

- Check e-mail is set for sending using Web Image Monitor's [Auto E-mail Notification] at the time the error was fixed. You must click the [Edit] button of [Detailed Settings of Each Item] in [Auto E-mail Notification], and set [Notify when error:] to [Occurs & Fixed] on the displayed screen.

For details about the settings, see Web Image Monitor Help.

Alert Resolving is set for sending e-mail, but no Alert-resolved e-mail is sent.

- If the power of the printer is turned off after an alert occurs, and the alert is resolved during the time the power is off, no Alert-resolved e-mail is sent.

Alert Occurrence and Alert Resolving are set for sending e-mail, but while no Alert Occurrence mail is received, Alert-resolved e-mail is received.

- Alert-notification e-mail is not sent if the problem is resolved before sending. However, an Alert-resolved e-mail is sent.

Alert-notification level was changed, and e-mail stopped arriving.

- If an Alert-notification e-mail, set with the earlier notification level, arrives, later e-mail will not be sent, even if the notification level is changed after.

When no date information is included in sent e-mail, the mail server has a malfunction.

- Configure the setting for obtaining time information from the SNTP server. Refer to Web Image Monitor's Help to the settings.

Note

- If the printer is still not operating satisfactorily, contact your sales or service representative. Consult with the store where the printer was purchased for information about the location of sales or service representatives.

10. Removing Misfed Paper

This chapter explains how to remove misfed paper.

When Paper is Jammed

An error message appears if a paper misfeed occurs. The error message gives the location of the misfeed. Check the location and remove the paper.

CAUTION

- The inside of the machine could be very hot. Do not touch the parts with a label indicating the "hot surface". Otherwise, an injury might occur.

CAUTION

- Some of this machine's internal components get very hot. For this reason, take care when removing misfed paper. Not doing so could result in burns.

CAUTION

- When removing jammed paper or replacing toner, avoid getting toner (new or used) on your clothing. If toner comes into contact with your clothing, wash the stained area with cold water. Hot water will set the toner into the fabric and make removing the stain impossible.

CAUTION

- When removing jammed paper or replacing toner, avoid getting toner (new or used) on your skin. If toner comes into contact with your skin, wash the affected area thoroughly with soap and water.

Important

- Forcefully removing misfed paper may cause paper to tear and leave scraps of paper in the printer. This might cause a misfeed and damage the printer.
- When paper is misfed a number of times, the following are possible causes.
 - The control panel settings do not match the size or orientation of the loaded paper.
 - The paper feed roller is dirty.
- For details about cleaning the paper feed roller, see p.156 "Cleaning the Friction Pad and the Paper Feed Roller".
- Misfed paper may be covered with toner. Be careful not to get toner on your hands or clothes.
- Toner on prints made after removing misfed paper may be loose (inadequately fused). Make a few test prints until smudges no longer appear.

- Paper jams can cause pages to be lost. Check your print job for missing pages and reprint any pages that did not print out.
- If paper is still misfed after you have checked the above-mentioned causes, contact your sales or service representative.

Paper Misfeed Message (A)

The "⚠ (A) Remove misfeed in Trays. Opn & cls Frt. Cov." error message appears when a paper misfeed occurs in the bypass tray, standard paper feed tray, or paper feed section.

★ Important

- Forcefully removing misfed paper may cause paper to tear and leave scraps of paper in the printer. This might cause a misfeed and damage the printer.
- Remove the paper from the bypass tray before opening the front cover.

When the paper was fed from the bypass tray

1. Remove the misfed paper.

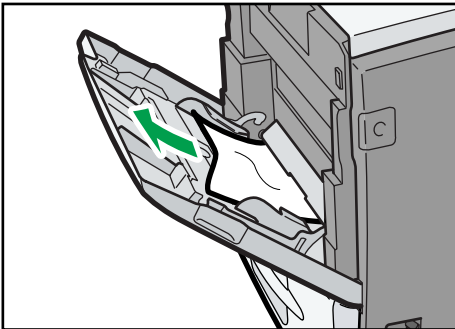

CEC251

2. Close the bypass tray.

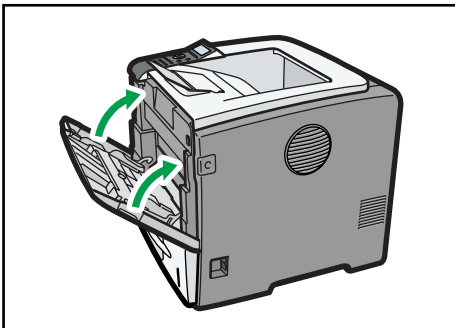

CEC252

3. Open the front cover by pushing the front cover release button, and then close it to reset the misfeed condition.

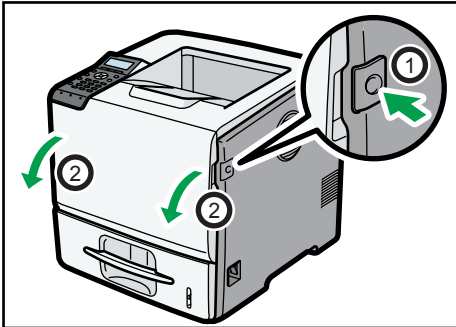

CEC025

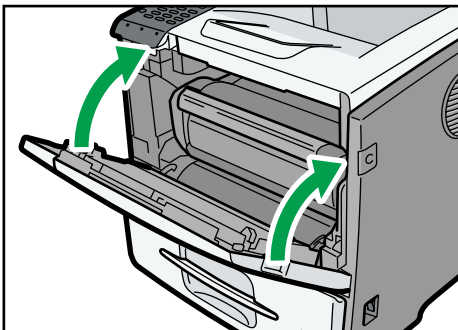

CEC214

When the paper was fed from the standard paper feed tray or the optional paper feed tray

1. Pull out the paper tray until it stops, and then remove misfed paper.

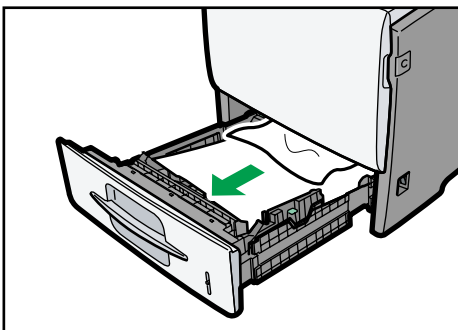

CEC228

2. Carefully slide the paper tray into the printer until it stops.

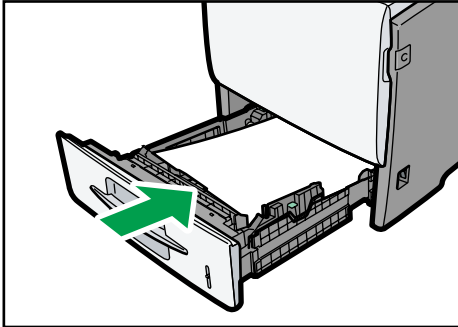

CEC229

3. Open the front cover by pushing the front cover release button.

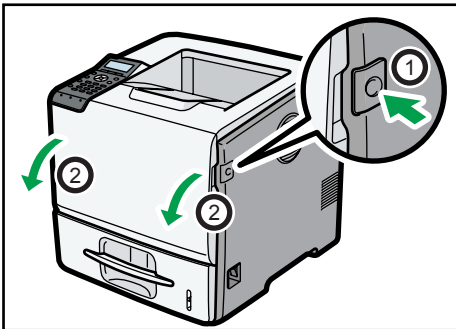

CEC025

4. Pull the print cartridge out of the printer by holding the grips of the cartridge.

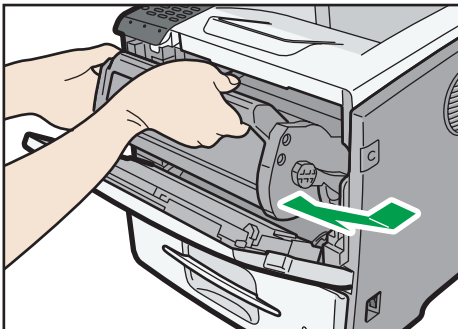

CEC026

5. Pull out the misfed paper by holding both sides of paper. Be careful not to get toner dust on your hands or clothes.

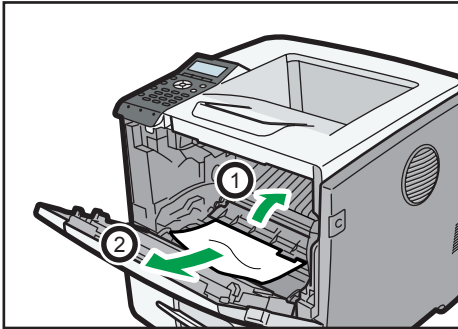

CEC080

6. Hold the grips of the print cartridge, and then push it into the printer until it stops.

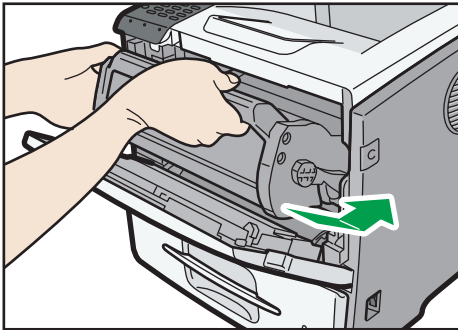

CEC028

7. Close the front cover.

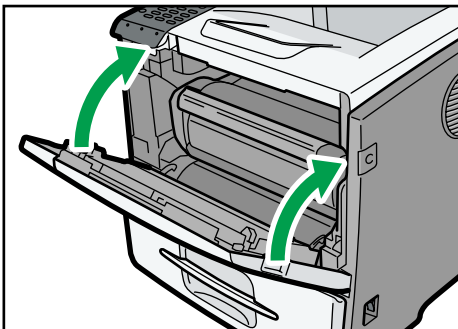

CEC214

Paper Misfeed Message (B)(C)

The "Error (B)(C) Open Front/Rear Cover and remove misfeed." error message appears when a paper misfeed occurs in the paper feed section.

★ Important

- Forcefully removing misfed paper may cause paper to tear and leave scraps of paper in the printer. This might cause a misfeed and damage the printer.
- If paper is fed from the bypass tray, be sure to remove all the paper from the bypass tray and close it before opening the front cover.
- Be sure to put the print cartridge on a stable, flat surface.
- Do not hold the print cartridge upside down or stand it vertically.

1. Open the front cover by pushing the front cover release button.

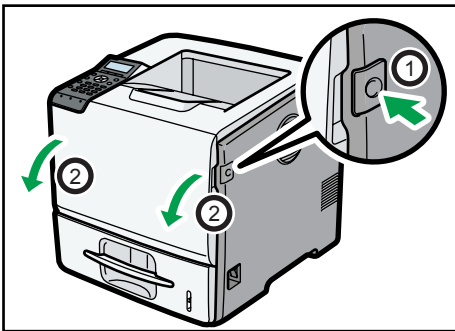

CEC025

2. Pull the print cartridge out of the printer by holding the grips of the cartridge.

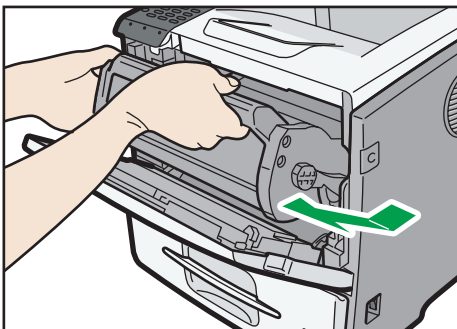

CEC026

3. Pull out the misfed paper by holding both sides of paper. Be careful not to get toner dust on your hands or clothes.

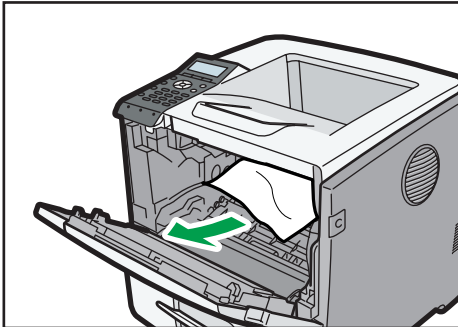

CEC246

4. Hold the grips of the print cartridge, and then push it into the printer until it stops.

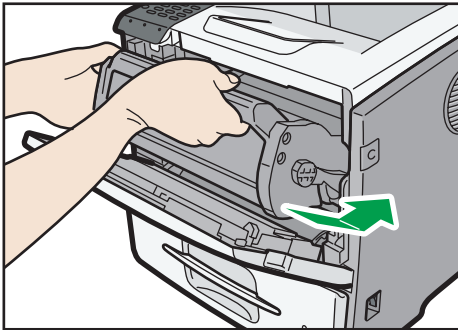

CEC028

If the printer does not recover from the error, a paper jam may have occurred in another location. In that case, proceed to the following steps.

5. Open the rear cover.

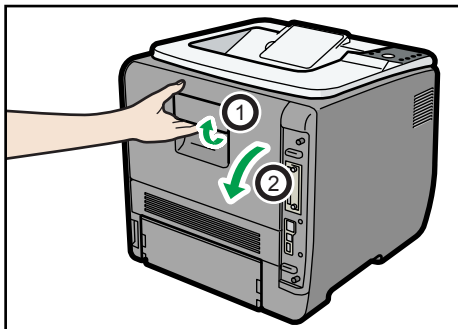

CEC046

6. Lift the lock levers of the fusing unit as shown in the illustration.

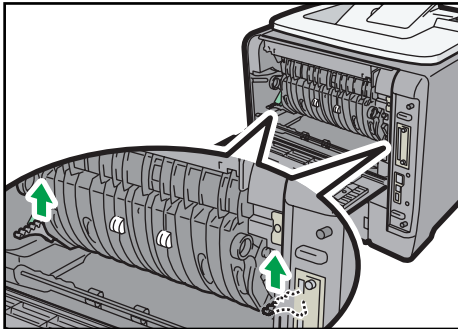

CEC050

7. Pull the fusing unit out.

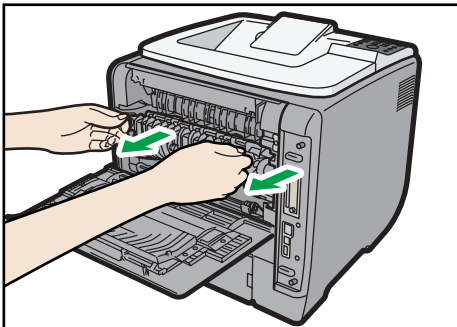

CEC052

8. Hold the tab, and then remove the misfed paper.

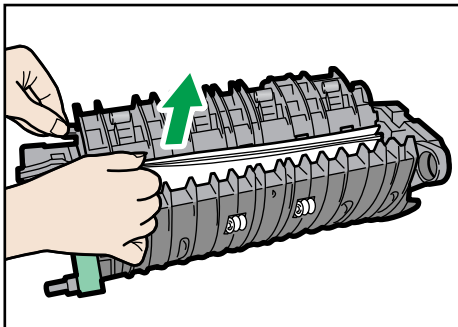

CEC087

9. Push the fusing unit until it stops.

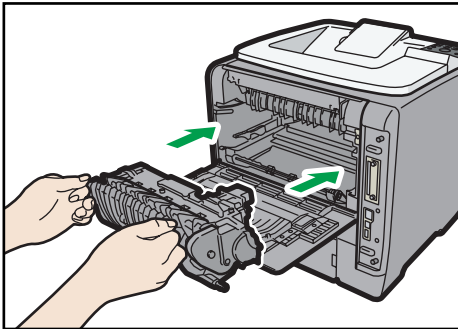

CEC053

10. Push the lock levers of the fusing unit down until they click.

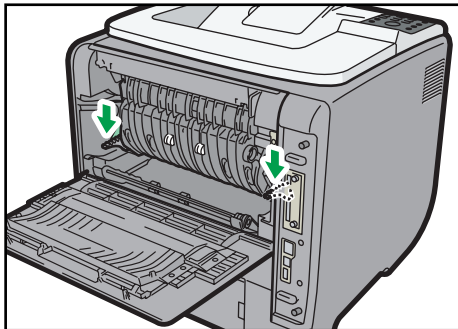

CEC051

11. Close the rear cover.

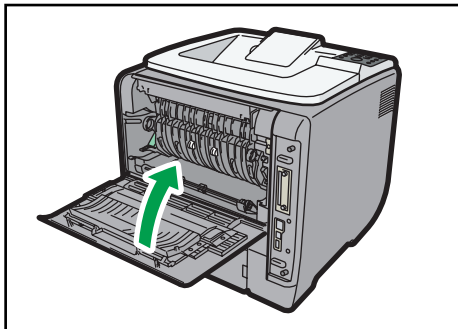

CEC049

12. Close the front cover.

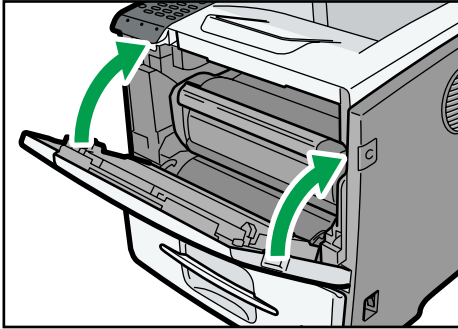

CEC214

Paper Misfeed Message (Y1)(Y2)(Y3)(Y4)

When a paper jam has occurred in one of the optional paper trays, "Tr(Y1)~(Y4) Remove misfeed in (Tray name). Opn & cls Frt. Cov." message appears. The optional paper trays to which this message applies to are as follow:

- (Y1): Tray 2
- (Y2): Tray 3
- (Y3): Tray 4
- (Y4): Tray 5

This section explains how to remove the jammed paper using tray 2 as an example. The same procedure can be used for the other optional trays.

★ Important

- Forcefully removing misfed paper may cause paper to tear and leave scraps of paper in the printer. This might cause a misfeed and damage the printer.

1. Pull out the paper tray until it stops, and then remove misfed paper.

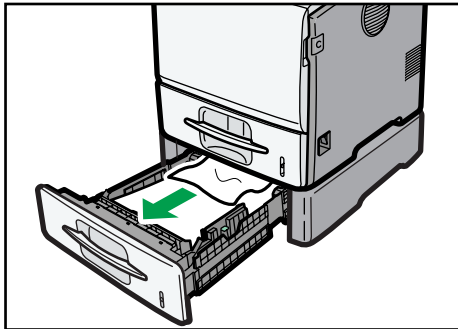

CEC084

10

If paper jams occur in multiple trays, a message indicating multiple trays such as "(Y2) (Y3)" appears. Open all the trays indicated on the control panel, and then remove the jammed paper.

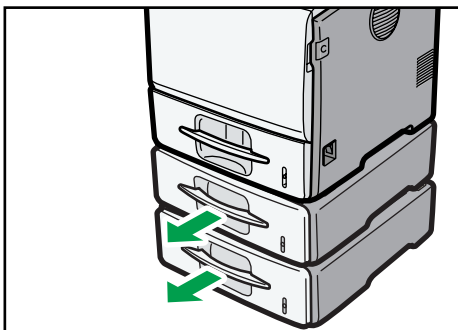

CEC085

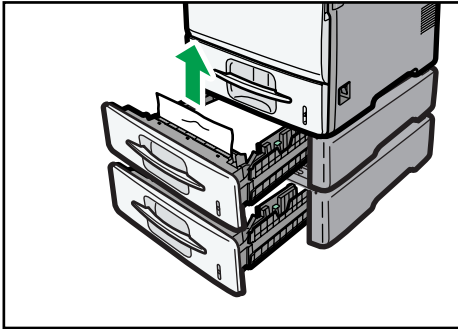

CEC086

2. Carefully slide the paper tray into the printer until it stops.

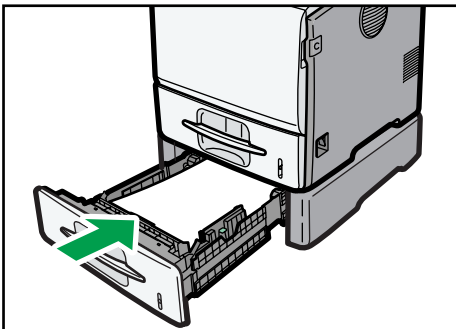

CEC083

3. Open the front cover by pushing the front cover release button, and then close it to reset the misfeed condition.

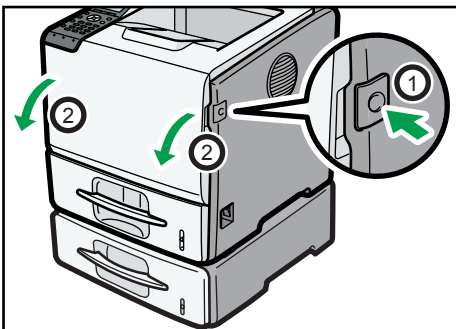

CEC081

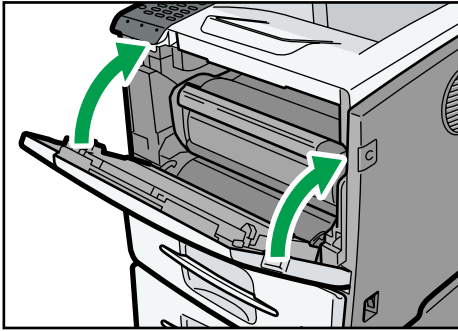

CEC082

Paper Misfeed Message (Z1)(Z2)

The "8r(Z1)(Z2) Opn R.Cov/Tray1 & remove ppr. Opn & cls F.Cov" error message appears when a paper misfeed occurs inside the duplex section.

★ Important

- Forcefully removing misfed paper may cause paper to tear and leave scraps of paper in the printer. This might cause a misfeed and damage the printer.
- If paper is fed from the bypass tray, be sure to remove all the paper from the bypass tray and close it before opening the front cover.

1. Open the rear cover.

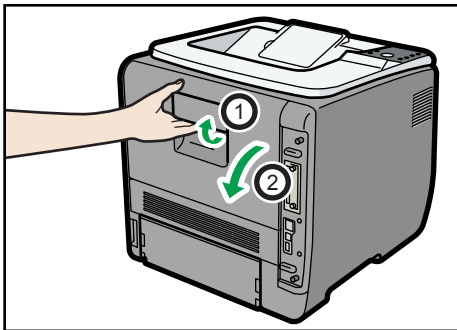

CEC046

2. Remove the misfed paper.

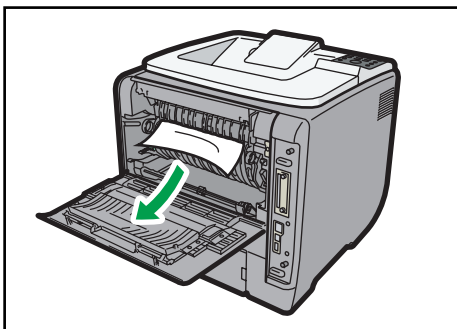

CEC234

3. Close the rear cover.

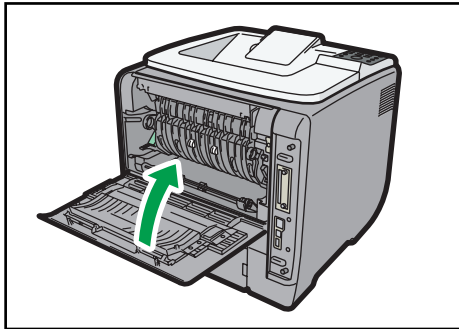

CEC049

If the printer does not recover from the error, a paper jam may have occurred in another location. In that case, proceed to the following steps.

4. Lift and pull Tray 1 carefully, and then pull it out with both hands.

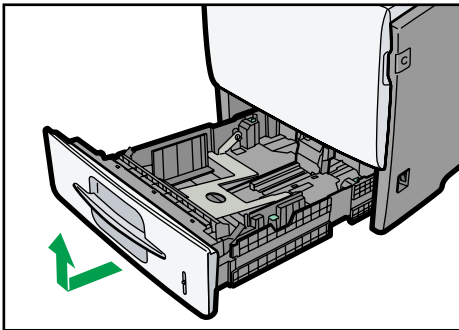

CEC031

5. Push down on the Z2 lever, and remove the jammed paper.

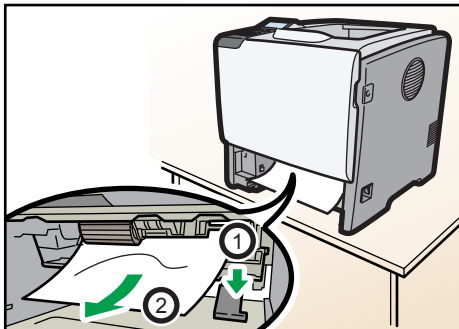

CEC079

6. Hold the tray with both hands, slide it along the rails of the printer body, and then push it straight in.

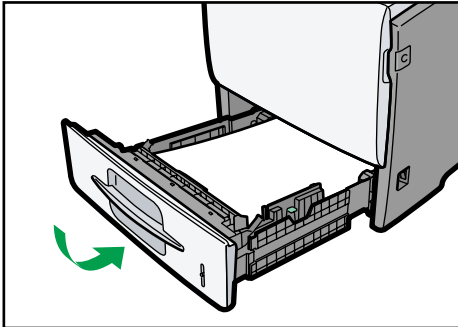

CEC032

7. Open the front cover by pushing the front cover release button, and then close it to reset the misfeed condition.

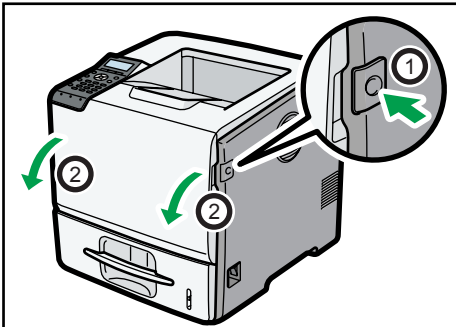

CEC025

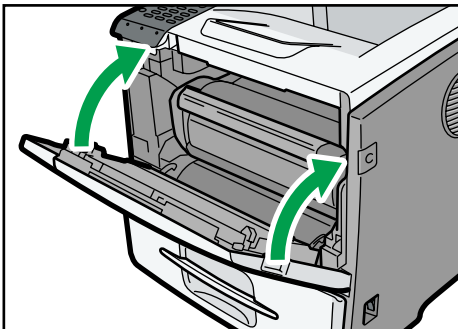

CEC214

11. Appendix

This section explains maintenance and operation procedures for this printer. It also describes the specifications of the printer and its options.

Moving and Transporting the Printer

WARNING

- If the machine topples, or if a cover or other part gets broken, you must turn the power switch to off and disconnect the power cord plug from the wall outlet. Then contact your service representative and report the problem. Do not use the machine. Doing so could result in fire or electric shock.

CAUTION

- The printer weighs approximately 23 kg (51 lb.). When moving the printer, use the inset grips on both sides, and lift slowly in pairs. The printer will break or cause injury if dropped.

CAUTION

- When disconnecting the power cord from the wall outlet, always pull the plug, not the cord. Pulling the cord can damage the power cord. Use of damaged power cords could result in fire or electric shock.

CAUTION

- Unplug the power cord from the wall outlet before you move the machine. While moving the machine, take care that the power cord is not damaged under the machine. Failing to take these precautions could result in fire or electric shock.

Important

- **Be sure to disconnect all cables from the printer before transporting it.**
- **The printer is a piece of precision machinery. Take care to avoid damage during transportation.**
- **If optional paper feed units are attached, remove them from the printer and move them separately.**

Moving the Printer in a Short Distance

1. Be sure to check the following points:

- The power switch is turned off.
- The power cord is unplugged from the wall outlet.

- The interface cable is unplugged from the printer.

2. If any external options are attached, remove them.

See the relevant sections in this manual and reverse the steps to remove options.

3. Lift the printer with two people by using the inset grips on both side of the printer, and then move it horizontally to the place where you want to install it.

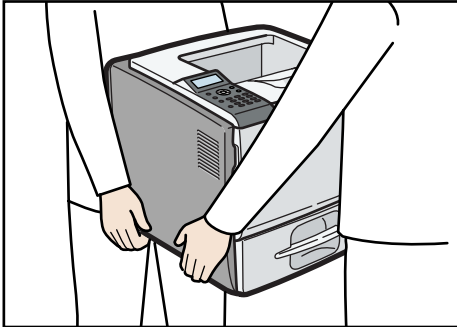

CEC045

4. If you removed options, reattach them.

For details, see the relevant sections in this manual.

↓ Note

- Be sure to move the printer horizontally. To prevent toner from scattering, move the printer slowly.

Consumables

⚠ CAUTION

- Our products are engineered to meet the highest standards of quality and functionality. When purchasing expendable supplies, we recommend using only those specified by an authorized dealer.

Print Cartridge

| Print cartridge | Average number of pages printable per cartridge ^{*1} |
|---|---|
|  Region B Black | 12,000 pages |
| Black (High yield) | 25,000 pages |

*1 The printable number of pages is based on pages that are compliant with ISO/IEC 19752 and the image density set as the factory default. ISO/IEC 19752 is an international standard on measurement of printable pages, set by the International Organization for Standardization.

The number of printable pages varies depending on which of the two different types of print cartridge you have installed.

↓ Note

- If print cartridges are not changed when necessary, printing will become impossible. We recommend keeping a stock of cartridges or purchasing them soon.
- The actual number of printable pages varies depending on the image volume and density, number of pages to be printed at a time, paper type and paper size used, and environmental conditions such as temperature and humidity.
- Print cartridges may need to be changed sooner than indicated above due to deterioration over the period of use.
- Print cartridges (consumables) are not covered by warranty. However, if there is a problem, contact the store where they were purchased.
- Numbers of pages that can be printed using the print cartridge supplied with this printer are as follows:

| Name | Average printable number of pages |
|-----------------|-----------------------------------|
| Print Cartridge | 6,000 pages |

- This printer routinely performs cleaning and uses toner during operation to maintain quality.

- To prevent a cleaning malfunction, you may need to replace a print cartridge even if it is not empty.

Maintenance Kit

| Name | Average printable number of pages |
|--|-----------------------------------|
| Maintenance Kit SP 5200 (includes a fusing unit, transfer roller, and paper feed roller) | 120,000 pages |

↓ Note

- The actual number of printable pages varies depending on the image volume and density, number of pages to be printed at a time, paper type and paper size used, and environmental conditions such as temperature and humidity.
- The maintenance kit are not covered by warranty. However, if there is problem, contact the store where they were purchased.

Specifications

WARNING

- The supplied power cord is for use with this machine only. Do not use it with other appliances. Doing so could result in fire, electric shock, or injury.

Mainframe



Configuration:

Desktop

Print Process:



Laser beam scanning & Electrophotographic printing

First Print Speed:

7.5 sec or less (A4  or 8 1/2 " x 11 " (Letter) 

Note that if the printer has not been used for some time, there may be a short delay before the first page starts printing.

Printing Speed:

| Model types | Printing Speed: A4  | Printing Speed: 8 1/2 " x 11 " (Letter)  |
|-------------|--|---|
| Type 1 | maximum 45 pages per minute | maximum 47 pages per minute |
| Type 2 | maximum 50 pages per minute | maximum 52 pages per minute |

Resolution:

600 x 600 dpi

1200 x 600 dpi

Paper Size:

For details, see p.101 "Supported Paper for Each Tray".

Paper Weight:

For details, see p.101 "Supported Paper for Each Tray".

Media Type:

For details, see p.105 "Supported Paper Types".



Paper Output Capacity:

Standard 500 sheets (80 g/m², 20 lb.)

Paper Input Capacity

For details, see p.101 "Supported Paper for Each Tray".

Power Source:

-  **Region A** (mainly Europe and Asia)
220-240 V, 50/ 60 Hz, 6 A or less
-  **Region B** (mainly North America)
120 - 127 V, 60 Hz, 11 A or less

Power Consumption:

| | |
|----------------------------|----------------|
| Printing | 1400 W or less |
| Auto Off mode (sleep mode) | 5 W or less |

Warm-up Time:

Less than 20 seconds (23 °C, 71.6 °F) *1

*1 When no error is occurred.

Dimensions (W × D × H):

Printer only (tray not extended): 411 × 435 × 400 mm (16.2 × 17.1 × 15.8 inches)

Weight:

Approximately 23 kg (51 lb.) (Toner included)

Noise Emission: *1

- Sound Power Level
 - Main unit only (Type 1)

| | |
|----------|-----------------------|
| Stand-by | Less than 46.5 dB (A) |
| Printing | Less than 71.8 dB (A) |

- Main unit only (Type 2)

| | |
|----------|-----------------------|
| Stand-by | Less than 48.0 dB (A) |
| Printing | Less than 72.0 dB (A) |

- Complete system (Type 1)

| | |
|----------|-----------------------|
| Stand-by | Less than 50.5 dB (A) |
| Printing | Less than 75.8 dB (A) |

- Complete system (Type 2)

| | |
|----------|-----------------------|
| Stand-by | Less than 52.0 dB (A) |
| Printing | Less than 76.0 dB (A) |

- Sound Pressure Level *2

- Main unit only (Type 1)

| | |
|----------|-----------------------|
| Stand-by | Less than 40.5 dB (A) |
| Printing | Less than 65.8 dB (A) |

- Main unit only (Type 2)

| | |
|----------|-----------------------|
| Stand-by | Less than 42.0 dB (A) |
| Printing | Less than 66.0 dB (A) |

- Complete system (Type 1)

| | |
|----------|-----------------------|
| Stand-by | Less than 44.5 dB (A) |
| Printing | Less than 69.8 dB(A) |

- Complete system (Type 2)

| | |
|----------|-----------------------|
| Stand-by | Less than 46.0 dB (A) |
| Printing | Less than 70.0 dB(A) |

*1 The preceding measurements made in accordance with ISO 7779 are actual values.

*2 Measured at the position of a bystander.

Memory:

- Type 1:
Standard 256 MB, up to 768 MB (with the optional SDRAM module)
- Type 2:
Standard 768 MB

Hard disk:

- Type 1:
80 GB (Optional)
- Type 2:
80 GB (Standard)

Interfaces:

Standard:

- Ethernet (10BASE-T/100BASE-TX)
- USB 2.0

To use USB 2.0, a USB computer port and cable that support USB 2.0 are required.

- USB Host

Optional:

- IEEE 802.11 a/b/g (Wireless LAN)
- Parallel (Bidirectional IEEE 1284)
- Gigabit Ethernet (1000BASE-T)

Printer Language:

PCL5e/PCL6, PostScript 3/PDF

Fonts:

PCL 5e/PCL 6:

45 fonts, 13 International fonts

PostScript 3, PDF:

136 fonts

Network:

Topology: The physical or logical layout of the nodes (devices) in a network. (10BASE-T/100BASE-TX/1000BASE-T)

Protocol: TCP/IP, IPX/SPX, AppleTalk

Options

Paper Feed Unit TK1120

Paper Size:

For details, see p.101 "Supported Paper for Each Tray".

Dimensions (W × D × H):

Less than 400 × 435 × 150 mm (15.8 × 17.1 × 5.9 inches)

Paper weight:

52 - 220 g/m² (14 - 59 lb.)

Weight:

Less than 7 kg (15.5 lb.)

Paper Feed Unit TK1130

Paper Size:

For details, see p.101 "Supported Paper for Each Tray".

Dimensions (W × D × H):

Less than 755 × 725 × 215 mm (29.7 × 28.6 × 8.5 inches)

Paper weight:

52 - 220 g/m² (14 - 59 lb.)

Weight:

Less than 8 kg (17.7 lb.)

Hard Disk Drive Type 2670

Storage Capacity (Formatted):

80 GB

Specifications:

- Spooling print data to collate
- Spooling Sample Print/Locked Print/Hold Print/Stored Print data
- Storing log data

↓ Note

- Storage capacity is subject to change without prior notice.
- The optional hard disk is provided with an SD card to enhance the security features. By using the provided SD card, the following security features to prevent data leaks become available: overwriting data on the optional hard disk, and encrypting the address book data, authentication information, and the data for stored prints.

Memory Unit Type G 256 MB

Module Type:

DIMM (Dual-in-line Memory Module)

Memory Type:

DDR-SDRAM (Double Data Rate Synchronous Dynamic RAM)

Number of Pins:

200 pins

Memory Unit Type I 512 MB

Module Type:

DIMM (Dual-in-line Memory Module)

Memory Type:

DDR-SDRAM (Double Data Rate Synchronous Dynamic RAM)

Number of Pins:

200 pins

Gigabit Ethernet Board Type A

Interface Connector:

Ethernet (10BASE-T, 100BASE-TX, 1000BASE-T)

USB 2.0

To use USB 2.0, a USB computer port and cable that support USB 2.0 are required.

Data Transmission Speed: Ethernet: 10 Mbps, 100 Mbps, 1000 Mbps

USB: 480 Mbps (High speed: USB 2.0), 12Mbps (Full speed)

Protocol:

TCP/IP, IPX/SPX, AppleTalk

Maximum Length of Cable Between Devices:

Ethernet: 100 m

USB: 5 m

IEEE 802.11a/g Interface Unit Type M Region A (mainly Europe and Asia)

Transmission Specification:

Based on IEEE 802.11a/b/g (Wireless LAN)

Data Transfer Speed:

Auto select from the following speed:

1 Mbps, 2 Mbps, 5.5 Mbps, 6 Mbps, 9 Mbps, 11 Mbps, 12 Mbps, 18 Mbps, 24 Mbps, 36 Mbps, 48 Mbps, 54 Mbps

Frequency Range:

2412 to 2472 Mhz (1 to 13 Channels)

5180 to 5240 Mhz (36, 40, 44 and 48 Channels)

The channel in use might differ depending on the country.

The following channels are available : 2412 - 2462 Mhz (1-11 Channels)

Transmission Mode:

- Ad hoc
- infrastructure mode

IEEE 802.11 a/g Interface Unit Type L  Region B (mainly North America)

Transmission Specification:

Based on IEEE 802.11 a/b/g (Wireless LAN)

Data Transfer Speed:

Auto select from the following speed:

1 Mbps, 2 Mbps, 5.5 Mbps, 6 Mbps, 9 Mbps, 11 Mbps, 12 Mbps, 18 Mbps, 24 Mbps, 36 Mbps, 48 Mbps, 54 Mbps

Frequency Range:

2412 to 2472 Mhz (1 to 13 Channels)

5180 to 5240 Mhz (36, 40, 44 and 48 Channels)

Transmission Mode:

- Ad hoc
- infrastructure mode

IEEE 1284 Interface Board Type A

Transmission Specification:

IEEE 1284

Required Cable:

Standard IEEE 1284-compliant Micro Centronics 36-pin cable

Trademarks

Adobe, Acrobat, Acrobat Reader, PostScript, and Reader are either registered trademarks or trademarks of Adobe Systems Incorporated in the United States and/or other countries.

Apple, Macintosh, Mac OS, and Safari are trademarks of Apple Inc., registered in the U.S. and other countries.

Firefox® is a registered trademark of the Mozilla Foundation.

IPDS is a trademark of Ricoh Co., Ltd.

IPS is a trademark or registered trademark of Zoran Corporation and/or its subsidiaries in the United States or other countries.

Microsoft®, Windows®, Windows Server®, Windows Vista®, and Internet Explorer® are registered trademarks of Microsoft Corporation in the United States and/or other countries.

Monotype is a registered trademark of Monotype Imaging, Inc.

PCL® is a registered trademark of Hewlett-Packard Company.

UNIX® is a registered trademark of The Open Group.

Other product names used herein are for identification purposes only and might be trademarks of their respective companies. We disclaim any and all rights to those marks.

The proper names of the Windows operating systems are as follows:

- The product names of Windows XP are as follows:
 - Microsoft® Windows® XP Professional Edition
 - Microsoft® Windows® XP Home Edition
- The product names of Windows Vista are as follows:
 - Microsoft® Windows Vista® Ultimate
 - Microsoft® Windows Vista® Business
 - Microsoft® Windows Vista® Home Premium
 - Microsoft® Windows Vista® Home Basic
 - Microsoft® Windows Vista® Enterprise
- The product names of Windows 7 are as follows:
 - Microsoft® Windows® 7 Home Premium
 - Microsoft® Windows® 7 Professional
 - Microsoft® Windows® 7 Ultimate
 - Microsoft® Windows® 7 Enterprise
- The product names of Windows Server 2003 are as follows:
 - Microsoft® Windows Server® 2003 Standard Edition

Microsoft® Windows Server® 2003 Enterprise Edition

- The product names of Windows Server 2003 R2 are as follows:

Microsoft® Windows Server® 2003 R2 Standard Edition

Microsoft® Windows Server® 2003 R2 Enterprise Edition

- The product names of Windows Server 2008 are as follows:

Microsoft® Windows Server® 2008 Standard

Microsoft® Windows Server® 2008 Enterprise

Microsoft® Windows Server® 2008 Standard without Hyper-V™

Microsoft® Windows Server® 2008 Enterprise without Hyper-V™

- The product names of Windows Server 2008 R2 are as follows:

Microsoft® Windows Server® 2008 R2 Standard

Microsoft® Windows Server® 2008 R2 Enterprise

INDEX

A

| | |
|---------------------------------|-----|
| Additional troubleshooting..... | 188 |
| Adjusting the paper type..... | 168 |
| Alert indicator..... | 24 |
| Alert messages..... | 172 |
| Automatically..... | 121 |
| Available options..... | 45 |

B

| | |
|------------------|-------------------------|
| Bypass tray..... | 104, 126, 127, 129, 131 |
|------------------|-------------------------|

C

| | |
|---------------------------------------|----------|
| CAUTION label..... | 9 |
| Cautions when cleaning..... | 155 |
| CD-ROM..... | 14 |
| Checking the port connection..... | 179 |
| Cleaning the registration roller..... | 159 |
| Clear key..... | 27 |
| Color paper..... | 109 |
| Consumables..... | 211 |
| Control panel..... | 23 |
| Custom size paper..... | 123, 129 |

D

| | |
|-------------------------|----|
| Data in indicator..... | 24 |
| Device certificate..... | 94 |
| DHCP..... | 78 |
| Display..... | 23 |
| Display language..... | 43 |
| Display panel..... | 25 |

E

| | |
|--------------------------------|--------|
| Entering characters..... | 26 |
| Envelopes..... | 110 |
| Error message..... | 171 |
| Escape key..... | 24, 26 |
| Ethernet..... | 75, 95 |
| Ethernet cable connection..... | 69 |
| Ethernet configuration..... | 75 |
| Ethernet speed..... | 81 |
| Exterior..... | 17, 19 |

F

| | |
|-------------------|-----|
| Friction pad..... | 156 |
|-------------------|-----|

G

| | |
|-----------------------------|----|
| Gigabit Ethernet board..... | 59 |
|-----------------------------|----|

H

| | |
|-----------------------------|----|
| Hard disk drive..... | 52 |
| How to enter character..... | 27 |
| HTML manuals..... | 14 |

I

| | |
|--|--------|
| IEEE 1284 interface board..... | 63, 74 |
| IEEE 802.1X..... | 94 |
| Image density..... | 163 |
| Installing options..... | 45 |
| Installing the memory expansion units..... | 52 |
| Interface units..... | 59 |
| Interior..... | 21 |

J

| | |
|--------------------|----|
| Job reset key..... | 24 |
|--------------------|----|

L

| | |
|------------------------|-----|
| Label paper..... | 108 |
| LED lamps..... | 71 |
| Letterhead..... | 107 |
| List of options..... | 13 |
| Loading envelopes..... | 133 |
| Loading paper..... | 117 |

M

| | |
|--|----------|
| Machine types..... | 7 |
| Maintenance kit..... | 154, 212 |
| Manuals..... | 11, 14 |
| Menu key..... | 23 |
| Middle thick..... | 106 |
| Model-specific information..... | 7 |
| Moving and transporting..... | 209 |
| Moving the printer a short distance..... | 209 |

N

| | |
|----------------------------------|--------|
| NetWare..... | 80 |
| Network..... | 75, 84 |
| Network setting..... | 80 |
| No DHCP..... | 76 |
| Non-recommended paper types..... | 114 |

Number keys.....24, 26

O

OHP transparencies.....110

OK key.....24, 26

Operating instructions.....14

Operational status or messages.....25

Option.....25

Optional paper feed tray.....102, 117

Order of option installation.....45

Other printing problems.....181

P

Panel tone.....177

Paper feed roller.....156

Paper feed unit.....48, 117

Paper misfeed.....191

Paper Misfeed Message (A).....193

Paper Misfeed Message (B)(C).....197

Paper Misfeed Message (Y1)(Y2)(Y3)(Y4).....202

Paper Misfeed Message (Z1)(Z2).....205

Paper size.....122, 127, 143

Paper type.....124, 131

Parallel cable connection.....74

Place to install.....32

Plain paper.....105

Power indicator.....24

Power off.....39, 41

Power on.....39

Power switch symbols.....10

Preprinted paper.....109

Print area.....115

Print cartridge.....149, 211

Print test sheet.....165

Printer does not print.....178

Printer set up procedure.....31

Printing on fixed-orientation paper.....145

Printing position.....165

Prt.jobs.....25

R

Recycled paper.....109

Registration roller.....159

Removing the packaging materials.....36

Replace.....154

S

Scroll keys.....24, 26

SD card.....66

SDRAM module.....55

Security.....89

Selection keys.....23, 26

Shutdown.....39, 41

Site certificate.....94

Special paper.....108

Specifications.....213

SSID.....86

Standard paper feed tray.....101, 117

Status message.....171

Storing paper.....113

Supplies.....25

Supported paper.....101, 105

Suspend/resume key.....24

Switch functions key.....23

Symbols.....6

T

Test printing.....44

Thick paper.....106

Thin paper.....106

Toner.....149

Trademarks.....220

Troubleshooting.....171

U

USB cable connection.....72

User paper type.....147, 148

W

WARNING label.....9

WEP key.....89

Wireless LAN.....84, 87, 89, 97

Wireless LAN configuration.....84

Wireless LAN connectivity.....87

Wireless LAN interface unit.....61

WPA.....90

WPA2.....90

