



User Guide

© Copyright 2013 Hewlett-Packard Development Company, L.P.

Bluetooth is a trademark owned by its proprietor and used by Hewlett-Packard Company under license. Intel is a trademark of Intel Corporation in the U.S. and other countries. Microsoft and Windows are U.S. registered trademarks of Microsoft Corporation. SD Logo is a trademark of its proprietor.

The information contained herein is subject to change without notice. The only warranties for HP products and services are set forth in the express warranty statements accompanying such products and services. Nothing herein should be construed as constituting an additional warranty. HP shall not be liable for technical or editorial errors or omissions contained herein.

First Edition: June 2013

Document Part Number: 722962-001

Product notice

This guide describes features that are common to most models. Some features may not be available on your computer.

Software terms

By installing, copying, downloading, or otherwise using any software product preinstalled on this computer, you agree to be bound by the terms of the HP End User License Agreement (EULA). If you do not accept these license terms, your sole remedy is to return the entire unused product (hardware and software) within 14 days for a refund subject to the refund policy of your place of purchase.

For any further information or to request a full refund of the computer, please contact your local point of sale (the seller).

Safety warning notice

 **WARNING!** To reduce the possibility of heat-related injuries or of overheating the computer, do not place the computer directly on your lap or obstruct the computer air vents. Use the computer only on a hard, flat surface. Do not allow another hard surface, such as an adjoining optional printer, or a soft surface, such as pillows or rugs or clothing, to block airflow. Also, do not allow the AC adapter to come into contact with the skin or a soft surface, such as pillows or rugs or clothing, during operation. The computer and the AC adapter comply with the user-accessible surface temperature limits defined by the International Standard for Safety of Information Technology Equipment (IEC 60950).

Table of contents

| | |
|--|-----------|
| 1 Starting right | 1 |
| Best practices | 1 |
| Fun things to do | 1 |
| More HP resources | 2 |
| 2 Getting to know your computer | 4 |
| Finding your hardware and software information | 4 |
| Locating hardware | 4 |
| Locating software | 4 |
| Front | 4 |
| Right side | 5 |
| Left side | 7 |
| Back | 8 |
| Top | 8 |
| Bottom | 9 |
| Labels | 9 |
| Identifying the labels | 9 |
| 3 Connecting to a network | 10 |
| Connecting to a wireless network | 10 |
| Using the wireless controls | 10 |
| Using an Internet service provider | 10 |
| Setting up a WLAN | 11 |
| Configuring a wireless router | 11 |
| Protecting your WLAN | 11 |
| Connecting to a WLAN | 12 |
| Connecting to a wired network | 13 |
| Connecting to a local area network (LAN) | 13 |
| 4 Enjoying entertainment features | 14 |
| Volume control | 14 |
| Using the webcam | 14 |
| Using audio | 14 |
| Adjusting the volume | 14 |
| Connecting speakers | 14 |
| Connecting headphones | 15 |

| | |
|---|-----------|
| Using Beats Audio | 15 |
| Accessing Beats Audio | 15 |
| Using video | 15 |
| Using Intel Wireless Display and Wireless Music (select models only) | 15 |
| Managing your audio and video files | 15 |
| 5 Navigating using the keyboard and pointing devices | 16 |
| Using touch screen gestures | 16 |
| One-finger slide | 16 |
| Tapping | 17 |
| Scrolling | 17 |
| Pinching/stretching | 18 |
| Rotating (select models only) | 18 |
| Edge swipes | 18 |
| Right-edge swipe | 19 |
| Left-edge swipe | 19 |
| Top-edge swipe and bottom-edge swipe | 20 |
| Using the keyboard | 21 |
| Using the action keys | 22 |
| Using Microsoft Windows 8 shortcut keys | 23 |
| Using the integrated numeric keypad | 23 |
| 6 Managing power | 25 |
| Initiating Sleep and Hibernation | 25 |
| Intel Rapid Start Technology (select models only) | 25 |
| Manually initiating and exiting Sleep | 25 |
| Manually initiating and exiting Hibernation | 26 |
| Setting password protection on wakeup | 26 |
| HP CoolSense (select models only) | 26 |
| Refreshing your software content with Intel Smart Connect Technology (select models only) | 27 |
| Shutting down (turning off) the computer | 27 |
| 7 Managing and sharing information | 28 |
| Using a USB device | 28 |
| Connecting a USB device | 29 |
| Removing a USB device | 29 |
| Inserting and removing a memory card | 30 |
| 8 Maintaining peak performance | 31 |
| Performing routine maintenance | 31 |

| | |
|---|-----------|
| Using Disk Cleanup | 31 |
| Using Disk Defragmenter | 31 |
| Updating programs and drivers | 31 |
| Cleaning your computer | 32 |
| Cleaning products | 32 |
| Cleaning procedures | 32 |
| Cleaning the display | 32 |
| Cleaning the sides and cover | 32 |
| Cleaning the keyboard | 32 |
| Using security measures | 33 |
| Setting Windows passwords | 33 |
| Setting Setup Utility (BIOS) passwords | 34 |
| Using Internet security software | 34 |
| Installing software updates | 34 |
| Installing Windows updates | 34 |
| Updating software | 35 |
| 9 Using Setup Utility (BIOS) and HP PC Hardware Diagnostics (UEFI) | 36 |
| Starting Setup Utility (BIOS) | 36 |
| Updating the BIOS | 36 |
| Determining the BIOS version | 36 |
| Downloading a BIOS update | 37 |
| Using HP PC Hardware Diagnostics (UEFI) | 37 |
| Downloading HP PC Hardware Diagnostics (UEFI) to a USB device | 38 |
| 10 Backing up, restoring, and recovering | 39 |
| Creating recovery media and backups | 39 |
| Creating HP Recovery media | 40 |
| Restore and recovery | 41 |
| Using Windows Refresh for quick and easy recovery | 42 |
| Remove everything and reinstall Windows | 42 |
| Recovering using HP Recovery Manager | 43 |
| What you need to know | 43 |
| Using the HP Recovery partition (select models only) | 43 |
| Using HP Recovery media to recover | 44 |
| Changing the computer boot order | 44 |
| Removing the HP Recovery partition | 44 |
| 11 Troubleshooting | 46 |
| Wireless connection problems | 46 |

| | |
|--|-----------|
| Cannot connect to a WLAN | 46 |
| Cannot connect to a preferred network | 46 |
| Current network security codes are unavailable | 47 |
| Cannot connect to the wireless router | 47 |
| Network status icon is not displayed | 48 |
| Power problems | 48 |
| Computer will not turn on or start | 48 |
| Hard drive error | 48 |
| Computer is not responding | 49 |
| Computer shuts down unexpectedly | 49 |
| Display problems | 49 |
| The display is blank | 49 |
| Images on the screen are too large or too small, or the images are fuzzy | 49 |
| Keyboard and mouse problems | 49 |
| Audio problems | 51 |
| No sound is produced | 51 |
| Software problems | 52 |
| 12 Specifications | 53 |
| Input power | 53 |
| Operating specifications | 53 |
| 13 Electrostatic Discharge | 54 |
| Index | 55 |

1 Starting right

This computer is a powerful tool designed to enhance your work and entertainment. To get the most out of your computer, read this chapter to learn about best practices after setup, fun things to do with your computer, and where to get more HP resources.

Best practices

After you set up and register the computer, we recommend the following steps:

- If you haven't already done so, connect to a wired or wireless network. See details in [Connecting to a network on page 10](#).
- Become familiar with the computer hardware and software. For information, go to [Getting to know your computer on page 4](#) and [Enjoying entertainment features on page 14](#).
- Back up your hard drive by creating a recovery drive. See [Backing up, restoring, and recovering on page 39](#).

Fun things to do

- You know you can listen to music on the computer. But did you know that you can also stream live radio to the computer and listen to music or talk radio from all over the world? See [Using audio on page 14](#).
- Experience music the way the artist intended, with deep controlled base and clear, pure sound. See [Using Beats Audio on page 15](#).
- Use the new Windows 8 touch gestures for smooth control of images and pages of text. See [Using touch screen gestures on page 16](#).

More HP resources

You have already used *Setup Instructions* to turn on the computer and locate this guide. To locate product details, how-to information, and more, use this table.

| Resource | Contents |
|---|---|
| <i>Setup Instructions</i> | <ul style="list-style-type: none">• Overview of computer setup and features. |
| <i>Windows 8 Basics</i> guide | <ul style="list-style-type: none">• Overview of using Windows 8. |
| Help and Support From the Start screen, type h , and then select Help and Support . For U.S. support, go to http://www.hp.com/go/contactHP . For worldwide support, go to http://welcome.hp.com/country/us/en/wwcontact_us.html . | <ul style="list-style-type: none">• A broad range of how-to information and troubleshooting tips. |
| Instructional videos Go to http://www.hp.com/supportvideos (English only) | <ul style="list-style-type: none">• How-to videos about using the features of your computer. |
| <i>Upgrading and Servicing Guide</i> For U.S. support, go to http://www.hp.com/go/contactHP . For worldwide support, go to http://welcome.hp.com/country/us/en/wwcontact_us.html . | <ul style="list-style-type: none">• Instructions for upgrading or replacing components of your computer. |
| Troubleshooting See Troubleshooting on page 46 in this guide for more information. | <ul style="list-style-type: none">• Solutions to the following problems:<ul style="list-style-type: none">◦ Wireless connection problems◦ Power problems◦ Display problems◦ Keyboard and mouse problems◦ Audio problems◦ Software problems |
| <i>Safety & Comfort Guide</i> To access this guide, select HP Support Assistant on the Start screen, select My computer , and then select User guides , or go to http://www.hp.com/ergo . | <ul style="list-style-type: none">• Proper workstation setup.• Guidelines for posture and work habits that increase your comfort and decrease your risk of injury.• Electrical and mechanical safety information. |
| Worldwide support web page To get support in your language, go to http://welcome.hp.com/country/us/en/wwcontact_us.html . | <ul style="list-style-type: none">• Access to the following support options:<ul style="list-style-type: none">◦ Online chat with an HP technician.◦ Email support.◦ Support telephone numbers.◦ HP service center locations. |
| <i>Regulatory, Safety and Environmental Notices</i> To access this guide, select the HP Support Assistant app on the Start screen, select My computer , and then select User guides . | <ul style="list-style-type: none">• Important regulatory notices. |

| Resource | Contents |
|---|--|
| <i>Limited Warranty*</i> To access this guide, select the HP Support Assistant app on the Start screen, select My computer , and then select Warranty and services , or go to http://www.hp.com/go/orderdocuments . | <ul style="list-style-type: none">• Specific warranty information about this computer. |

*You can find the expressly provided HP Limited Warranty applicable to your product located with the user guides on your computer and/or on the CD/DVD provided in the box. In some countries/regions, HP may provide a printed HP Limited Warranty in the box. For countries/regions where the warranty is not provided in printed format, you may request a printed copy from <http://www.hp.com/go/orderdocuments> or write to:

- **North America:** Hewlett-Packard, MS POD, 11311 Chinden Blvd., Boise, ID 83714, USA
- **Europe, Middle East, Africa:** Hewlett-Packard, POD, Via G. Di Vittorio, 9, 20063, Cernusco s/Naviglio (MI), Italy
- **Asia Pacific:** Hewlett-Packard, POD, P.O. Box 200, Alexandra Post Office, Singapore 911507

When you request a printed copy of your warranty, please include your product number, warranty period (found on your service label), name, and postal address.

IMPORTANT: Do NOT return your HP product to the addresses above. For U.S. support, go to <http://www.hp.com/go/contactHP>. For worldwide support, go to http://welcome.hp.com/country/us/en/wwcontact_us.html.

2 Getting to know your computer

Finding your hardware and software information

Locating hardware

To find out what hardware is installed on your computer:

1. From the Start screen, type **c**, and then select **Control Panel**.
2. Select **System and Security**, and then in the System area, click **Device Manager**.

A list reveals all the devices installed on your computer.

Locating software

To find out what software is installed on your computer:

1. From the Start screen, right-click using the external wireless mouse.
– or –
Swipe down from the top edge of the computer screen.
2. Select the **All apps** icon.

Front

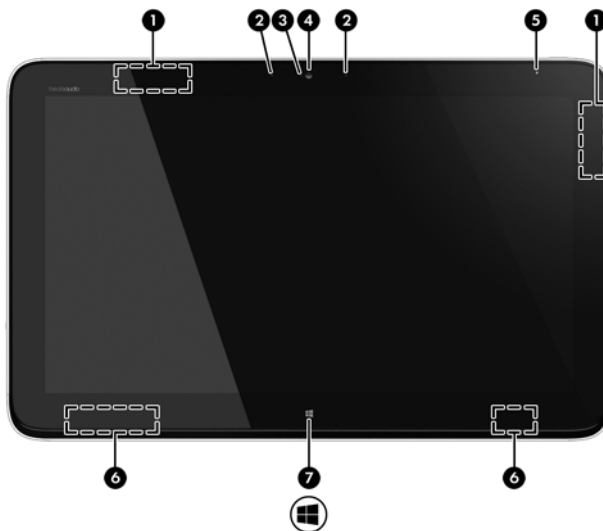

| Component | Description |
|-----------|---|
| (1) | WLAN antennas (2)* Send and receive wireless signals. |
| (2) | Internal microphones (2) Record audio, automatically filtering out the noise around you and cancelling echoes. |
| (3) | Webcam light On: The webcam is on. |



| Component | Description |
|--|--|
| (4) HP TrueVision HD Webcam | Records video, captures still photographs, and provides access to video conferences and online chat by means of streaming video. To use the webcam, from the Start screen, type c , and then select CyberLink YouCam from the list of applications. |
| (5) Ambient light sensor | Automatically adjusts the display brightness based on the lighting conditions in your environment. |
| (6) Speakers (2) | Produce sound. |
| (7)  Windows button | Returns you to the Start screen from an open app or the Windows desktop. NOTE: Pressing the Windows button again will return you to the previous screen. |

*The antennas are not visible from the outside of the computer. For optimal transmission, keep the areas immediately around the antennas free from obstructions. For wireless regulatory notices, see the section of the *Regulatory, Safety, and Environmental Notices* that applies to your country or region. These notices are located in Help and Support.

Right side





| Component | Description |
|---------------------------|--------------------------|
| (1) Volume control button | Controls speaker volume. |

| Component | Description |
|---|--|
| (2)  USB 3.0 charging (powered) port | Connects an optional USB device. USB charging ports allow you to charge connected USB devices. Standard USB ports will not charge all USB devices or will charge using a low current. Some USB devices require power and require you to use a powered port. NOTE: USB charging ports can also charge select models of cell phones and MP3 players, even when the computer is off. |
| (3)  Audio-out (headphone) jack/Audio-in (microphone) jack | Connects optional powered stereo speakers, headphones, earbuds, a headset, or a television audio cable. Also connects an optional headset microphone. This jack does not support optional microphone-only devices. WARNING! To reduce the risk of personal injury, adjust the volume before putting on headphones, earbuds, or a headset. For additional safety information, refer to the <i>Regulatory, Safety, and Environmental Notices</i> . NOTE: When a device is connected to the jack, the computer speakers are disabled. |

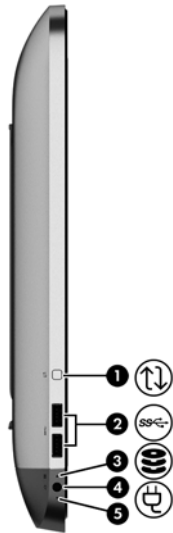
Left side



| Component | Description |
|---|--|
| (1) | Rotate button Rotates the orientation of the display 90 degrees. |
| (2)  | USB 3.0 ports (2) Connect optional USB 1.0, USB 2.0, or USB 3.0 devices and provide enhanced USB power performance for USB 3.0 devices. |
| (3)  | Hard drive light Blinking: The hard drive is being used. |
| (4)  | Power connector Connects an AC adapter. |
| (5) | AC adapter light <ul style="list-style-type: none">White: The AC adapter is connected and the battery is charged.Amber: The AC adapter is connected and the battery is charging.Off: The computer is using DC power. |

Back

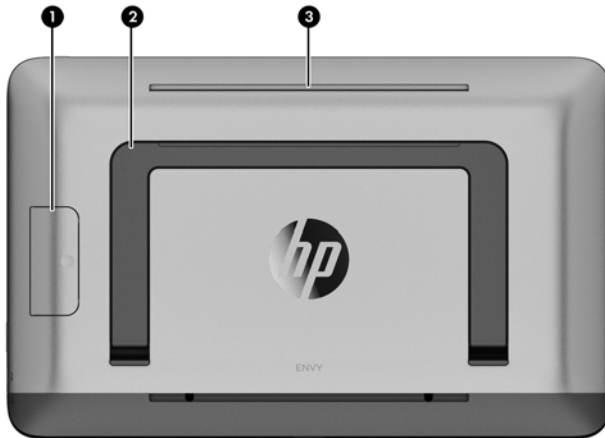

| Component | Description |
|--------------------------|--|
| (1) Stand release button | Releases the display stand. |
| (2) Display stand | Allows the display to be positioned at different angles. |
| (3) Vent | Enables airflow to cool internal components. |

NOTE: The computer fan starts up automatically to cool internal components and prevent overheating. It is normal for the internal fan to cycle on and off during routine operation.

Top



| Component | Description |
|------------------|---|
| (1) Power button | <ul style="list-style-type: none">When the computer is off, press the button to turn on the computer.When the computer is in the Sleep state, press the button briefly to exit Sleep.When the computer is in Hibernation, press the button down briefly to exit Hibernation. <p>CAUTION: Pressing and holding down the power button will cause unsaved information to be lost.</p> <p>If the computer has stopped responding and Windows® shutdown procedures aren't working, press and hold the power button for at least 5 seconds to turn off the computer.</p> <p>To learn more about your power settings, from the Start screen, type <code>p</code>. In the search box, type <code>power</code>, select Settings, and then select Power options.</p> |

Bottom

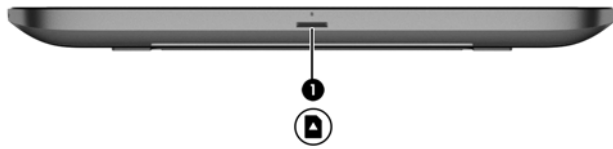

| Component | Description |
|------------------------|--|
| (1) Memory card reader | Reads data from and writes data to memory cards such as Secure Digital (SD). |

Labels

Identifying the labels

The labels on the computer provide information you may need when you troubleshoot problems. The labels are located underneath the display stand and are visible when the display stand is released.

- Service label—Provides important information to identify your computer. You will typically be asked for the product number when working with support. Locate this number before you contact support.
- Regulatory label—Provides regulatory information about the computer.
- Wireless certification label or labels (select models only)—Provide information about optional wireless devices and the approval markings of some of the countries or regions in which the devices have been approved for use. If your computer model includes one or more wireless devices, one or more certification labels are included with your computer. You may need this information when traveling internationally.

3 Connecting to a network

You can explore the globe and access information from millions of websites using your computer and a wired or wireless network connection. This chapter will help you get connected to that world.

Connecting to a wireless network

Wireless technology transfers information across radio waves instead of wires. Your computer may be equipped with one or more of the following wireless devices:

- Wireless local area network (WLAN) device—Connects the computer to wireless local area networks. In a WLAN, the mobile wireless device in your computer communicates with a wireless router or a wireless access point.
- Bluetooth® device—Creates a personal area network (PAN) to connect to other Bluetooth-enabled devices such as computers, phones, printers, headsets, speakers, and cameras. In a PAN, each device communicates directly with other devices, and devices must be relatively close together.

For more information about wireless technology, see the information and website links provided in Help and Support. From the Start screen, type **h**, and then select **Help and Support**.

Using the wireless controls

The Network and Sharing Center allows you to set up a connection or network, connect to a network, and diagnose and repair network problems.

To use the Network and Sharing Center:

1. From the Start screen, type **c**, and then select **Control Panel**.
2. Select **Network and Internet**, and then select **Network and Sharing Center**.

For more information, go to Help and Support. From the Start screen, type **h**, and then select **Help and Support**.

Using an Internet service provider

When you are setting up Internet access in your home, you must establish an account with an Internet service provider (ISP). To purchase Internet service and a modem, contact a local ISP. The ISP will help set up the modem, install a network cable to connect your wireless router to the modem, and test the Internet service.



NOTE: Your ISP will give you a user ID and a password to use for Internet access. Record this information and store it in a safe place.

Setting up a WLAN

To set up a WLAN and connect to the Internet, you need the following equipment:

- A broadband modem (either DSL or cable) **(1)** and high-speed Internet service purchased from an Internet service provider
- A wireless router **(2)** (purchased separately)

 **NOTE:** Some modems have a built-in wireless router. Check with your ISP to determine what type of modem you have.

- A wireless computer **(3)**

The illustration below shows an example of a wireless network installation that is connected to the Internet.

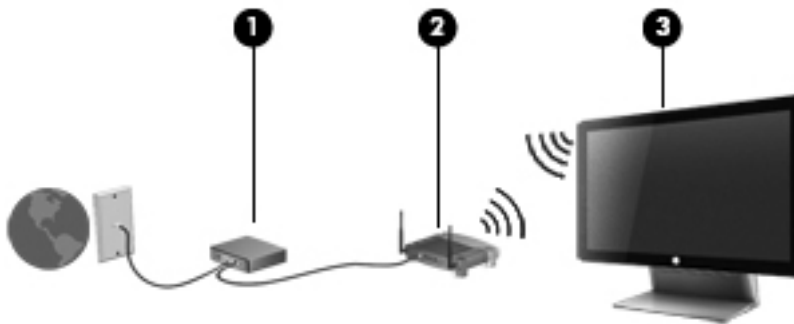

Additional wireless and wired computers can be connected to increase the size of your home network.

For help in setting up your WLAN, see the information provided by your router manufacturer or your ISP.

Configuring a wireless router

For help configuring a wireless router, see the information provided by your router manufacturer or your ISP.

 **NOTE:** It is recommended that you initially connect your new wireless computer to the router by using the network cable provided with the router. When the computer successfully connects to the Internet, disconnect the cable, and access the Internet through your wireless network.

Protecting your WLAN

When you set up a WLAN or connect to an existing WLAN, always enable security features to protect your network from unauthorized access.

Wireless radio signals travel outside the network, so other WLAN devices can pick up unprotected signals. Take the following precautions to protect your WLAN:

- Use a firewall.
A firewall checks and requests information that is sent to your network. It then discards any suspicious items. Firewalls are available in both software and hardware. Some networks use a combination of both types.
- Use wireless encryption.

Wireless encryption uses security settings to encrypt and decrypt information that is transmitted over the network. For more information, go to Help and Support. From the Start screen, type **h**, and then select **Help and Support**.

Connecting to a WLAN

To connect to a WLAN, follow these steps:

1. Be sure that the WLAN device in your computer is on.
2. From the Start screen, point to the far-right upper or lower corner of the screen to display the charms.
3. Select **Settings**, and then click the network status icon.
4. Select a WLAN from the list.
5. Click **Connect**.

If the WLAN is a security-enabled WLAN, you are prompted to enter a security code. Type the code, and then click **OK** to complete the connection.

 **NOTE:** If no WLANs are listed, you may be out of range of a wireless router or access point.

 **NOTE:** If you do not see the WLAN you want to connect to, from the Windows desktop, right-click the network status icon, and then select **Open Network and Sharing Center**. Click **Set up a new connection or network**. A list of options is displayed, allowing you to manually search for and connect to a network or to create a new network connection.

After the connection is made, place the pointer over the network status icon in the notification area, at the far right of the taskbar, to verify the name and status of the connection.

 **NOTE:** The functional range (how far the wireless signals travel) depends on WLAN implementation, router manufacturer, and interference from other electronic devices or structural barriers such as walls and floors.

Connecting to a wired network

⚠ WARNING! To reduce the risk of electric shock, fire, or damage to the equipment, do not plug a modem cable or telephone cable into an RJ-45 (network) jack.

Connecting to a local area network (LAN)

Use a LAN connection if you want to connect the computer directly to a router in your home (instead of working wirelessly), or if you want to connect to an existing network at your office.

Connecting to a LAN requires an 8-pin, RJ-45 (network) cable and an RJ-45 (network) USB adapter.

To connect the network cable, follow these steps:

1. Plug the RJ-45 (network) USB adapter **(1)** into a USB port on the computer.
2. Plug one end of the RJ-45 (network) cable **(2)** into the USB adapter.
3. Plug the other end of the network cable into a network wall jack **(3)** or router.

📝 NOTE: If the network cable contains noise suppression circuitry **(4)**, which prevents interference from TV and radio reception, orient the circuitry end of the cable toward the computer.

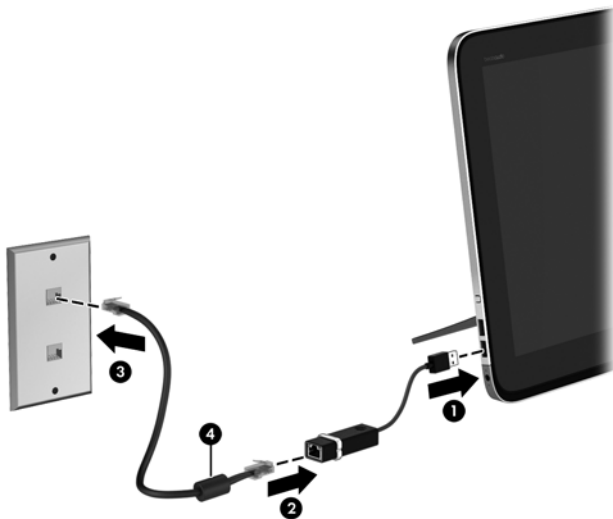

4 Enjoying entertainment features

Use your HP computer as an entertainment hub to socialize via the webcam, enjoy and manage your music, and download and watch movies. Or, to make your computer an even more powerful entertainment center, connect external devices like speakers, headphones, or a gaming console.

Volume control

The integrated volume control button controls speaker volume on the computer.

- ▲ To increase speaker volume, press and hold the + sign.
- ▲ To decrease speaker volume, press and hold the – sign.

Using the webcam

Your computer has an integrated webcam, a powerful social networking tool that allows you to communicate up close with friends and colleagues next door or on the other side of the world. With the webcam, you can stream video with your instant messaging software, capture and share video, and take still photos.

- ▲ To start the webcam, from the Start screen, type **c**, and then select **Camera**.

For details about using the webcam, go to Help and Support. From the Start screen, type **h**, and then select **Help and Support**.

Using audio

On your HP computer, you can play music CDs, download and listen to music, stream audio content from the web (including radio), record audio, or mix audio and video to create multimedia. To enhance your listening enjoyment, attach external speakers or headphones.

Adjusting the volume

1. From the Start screen, point to the far-right upper or lower corner of the screen to display the charms.
2. Select **Settings**, and then click the speaker icon.
3. Adjust the slider to increase or decrease the volume.

 **NOTE:** You can also adjust the volume using the volume keys on the external wireless keyboard or the volume control button. See [Using the action keys on page 22](#) or [Volume control on page 14](#) for more information.

Connecting speakers

You can attach wired speakers to your computer by connecting them to a USB port on your computer.

To connect *wireless* speakers to your computer, follow the device manufacturer's instructions. Before connecting speakers, lower the volume setting.

Connecting headphones

You can connect wired headphones to the headphone jack on your computer.

To connect *wireless* headphones to your computer, follow the device manufacturer's instructions.

 **WARNING!** To reduce the risk of personal injury, adjust the volume before putting on headphones, earbuds, or a headset. For additional safety information, see the *Regulatory, Safety and Environmental Notices*.

Using Beats Audio

You can experience Beats Audio through the computer's four internal speakers, through external speakers connected to a USB port, or through Beats Audio headphones connected to the headphone jack.

Accessing Beats Audio

Use Beats Audio Control Panel to view and manually control audio and bass settings.

- ▲ To open Beats Audio Control Panel, from Start screen, type **c**, select **Control Panel**, select **Hardware and Sound**, and then select **Beats Audio Control Panel**.

Using video

Your HP computer is a powerful video device that enables you to watch streaming video from your favorite websites and download video and movies to watch on your computer without needing to connect to a network.

Using Intel Wireless Display and Wireless Music (select models only)

Intel® Wireless Display and Wireless Music allow you to transmit your computer content wirelessly to your receive/display device, such as HDTV, monitor, projector, game console, Blu-ray player, or DVR, by using an optional wireless adapter (purchased separately). For details about using the wireless adapter, see the manufacturer's instructions.

- ▲ To open Intel Wireless Display, from the Start screen, type **w**, and then select **Intel WiDi**.

 **NOTE:** Before using the wireless display feature, be sure that your wireless device is turned on.

Managing your audio and video files

CyberLink MediaSuite helps you manage and edit your photo and video collections.

- ▲ To open CyberLink MediaSuite, from the Start screen, type **c**, and then select **CyberLink MediaSuite**.

For more information about using CyberLink MediaSuite, see the software Help.

5 Navigating using the keyboard and pointing devices

Your computer includes an external wireless keyboard and an external wireless mouse for easy navigation. After you remove the battery tabs from the accessories, they will automatically pair with the computer.

 **NOTE:** The wireless receiver is preinstalled in the dedicated USB port on the bottom of the computer stand. If you have any problems with the wireless accessories, remove the receiver from the USB port and then reconnect it. For additional information, see [Keyboard and mouse problems on page 49](#).

Using touch screen gestures

A touch screen computer allows you to control items on the screen directly with your fingers.

 **TIP:** On touch screen computers, you can perform the gestures on the screen or using the keyboard and mouse.

One-finger slide

The one-finger slide is mostly used to pan or scroll through lists and pages, but you can use it for other interactions, too, such as moving an object.

- To scroll across the screen, lightly slide one finger across the screen in the direction you want to move.

 **NOTE:** When many apps are revealed on the Start screen, you can slide your finger to move the screen left or right.

- To drag, press and hold an object, and then drag the object to move it.

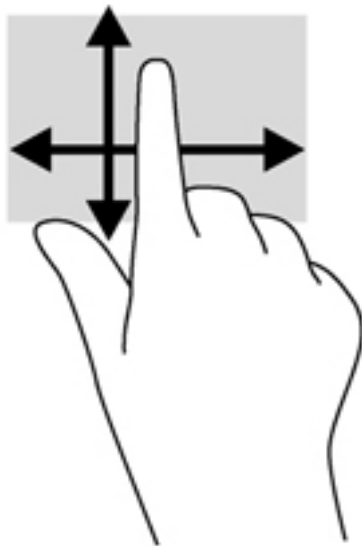

Tapping

To make an on-screen selection, use the tap function.

- Use one finger to tap an object on the screen to make a selection. Double-tap an item to open it.



Scrolling

Scrolling is useful for moving the pointer up, down, left, or right on a page or image.

- Place two fingers on the screen and then drag them in an up, down, left, or right motion.

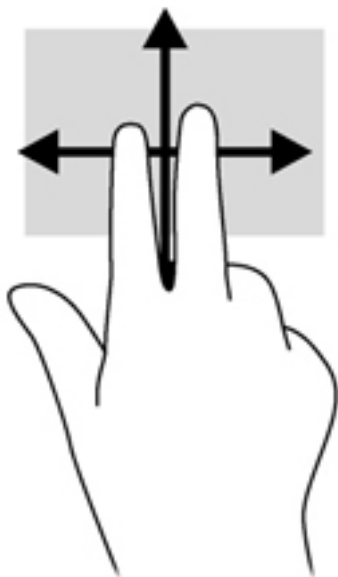

Pinching/stretching

Pinching and stretching allows you to zoom out or in on images or text.

- Zoom in by placing two fingers together on the display and then move your fingers apart.
- Zoom out by placing two fingers apart on the display and then move your fingers together.

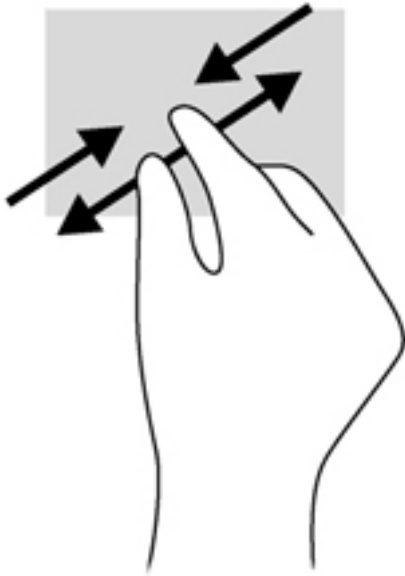

Rotating (select models only)

Rotating allows you to turn items such as photos.

- Anchor the forefinger of your left hand on the object you want to rotate. Using your right hand, slide your forefinger around in a sweeping motion from 12 o'clock to 3 o'clock. To reverse the rotation, move your forefinger from 3 o'clock to 12 o'clock.

 **NOTE:** Rotate is intended for specific apps where you can manipulate an object or image. Rotate may not be functional for all apps.

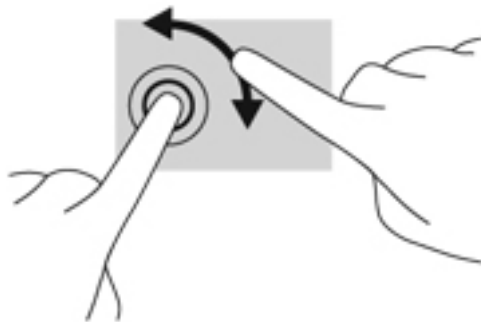

Edge swipes

With edge swipes you can perform tasks such as changing settings and finding or using apps.

Right-edge swipe

The right-edge swipe reveals the charms, which let you search, share, start apps, access devices, or change settings.

- Gently swipe your finger inward from the right edge of the display onto the screen to reveal the charms.

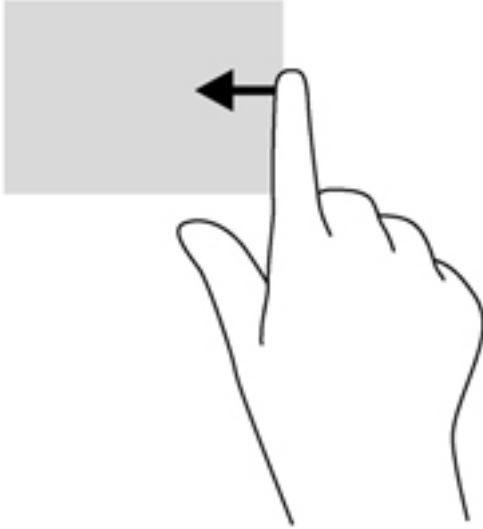

Left-edge swipe

The left-edge swipe reveals your open apps so that you can switch to them quickly.

- Gently swipe your finger inward from the left edge of the display to switch between apps. Without lifting your finger, swipe back toward the left edge to reveal all open apps.

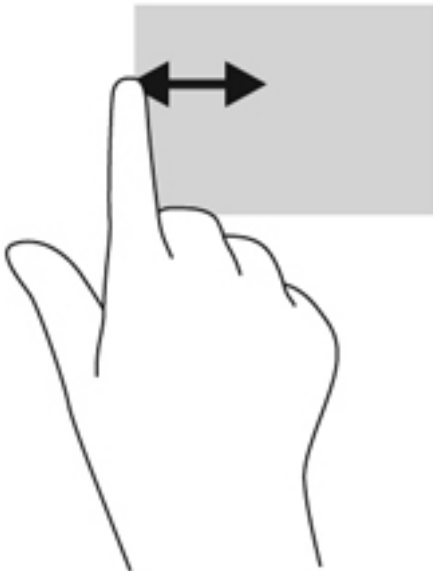

Top-edge swipe and bottom-edge swipe

The top-edge swipe or bottom-edge swipe allows you to open a list of apps available on your computer.

1. From the Windows Start screen, gently swipe your finger from the top edge or the bottom edge of the display onto the screen.
2. Tap **All apps** to view available apps.

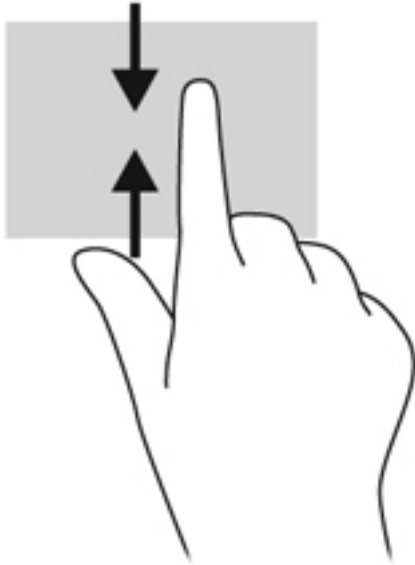





Using the keyboard

With the keyboard, you can type to select items and perform the same functions as you do by using touch gestures. The keyboard also allows you to use action keys to perform specific functions.

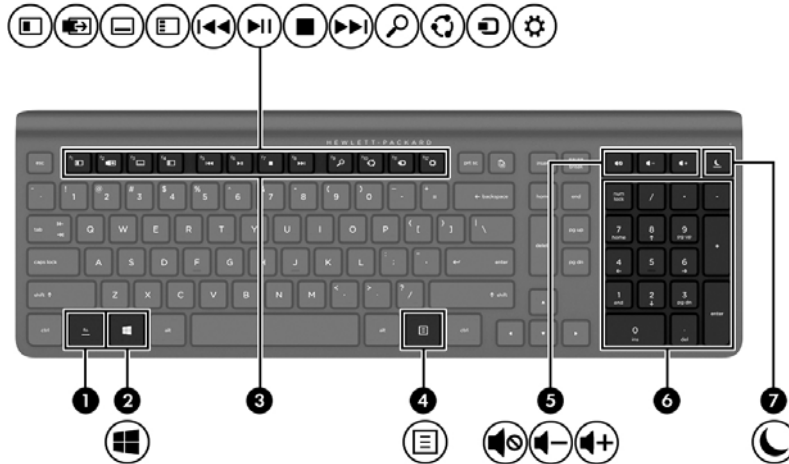
TIP: The Windows logo key  on the keyboard allows you to quickly return to the computer Start screen from an open app or the Windows desktop. Pressing the Windows logo key again will return you to the previous screen.

NOTE: Depending on the country or region, your keyboard may have different keys and keyboard functions than those discussed in this section.



















| Component | Description |
|---|--|
| (1)  Fn key | Executes frequently used system functions when pressed in combination with an action key. |
| (2)  Windows logo key | Returns you to the Start screen from an open app or the Windows desktop. Pressing the key again returns you to the previous screen. |
| (3) Action keys | Perform common tasks. |
| (4)  Windows application key | Displays options for a selected object. |
| (5) Volume keys | Mute or restore speaker sound, and decrease or increase speaker volume incrementally as long as you hold down the key. |
| (6) Integrated numeric keypad | Set at the factory to function like an external numeric keypad. To alternate between this numeric function and the navigational function (indicated by the directional arrows on the keys), press the num lock key. |
| (7)  Sleep key | Initiates Sleep, which saves your information in the system. The display and other system components turn off and power is conserved. To exit Sleep, briefly press the power button. CAUTION: To reduce the risk of information loss, save your work before initiating Sleep. WARNING! If a critical battery level occurs while the computer is in the Sleep state, the computer initiates Hibernation and the information stored is saved to the hard drive. |

Using the action keys

An action key performs an assigned function. The icon on each of the **f1** through **f12** keys, and the volume (**5**), and Sleep (**7**) keys illustrates the assigned function for that key.

▲ To use an action key function, press and hold the key.

| Icon | Key | Description |
|---|------------|--|
|  | f1 | Allows you to view two apps simultaneously. The apps are displayed side by side. |
|  | f2 | Switches between open apps. NOTE: Continue to press this key until the app you want is displayed. |
|  | f3 | Shows the commands available in an app. |
|  | f4 | Shows a list of recently used apps. |
|  | f5 | Plays the previous track of an audio CD or the previous section of a DVD or a Blu-ray Disc (BD). |
|  | f6 | Begins, pauses, or resumes playback of an audio CD, a DVD, or a BD. |
|  | f7 | Stops playing an audio CD, DVD, or a BD. |
|  | f8 | Plays the next track of an audio CD or the next section of a DVD or a BD. |
|  | f9 | Opens the Search charm. Allows you to search an open app or another app, your computer, and the Internet. |
|  | f10 | Opens the Share charm. Allows you to share pictures, files, or webpages. |
|  | f11 | Opens the Devices charm. Allows you to set up printers and synchronize data with your phone and stream video to your wireless TV. |
|  | f12 | Opens the Settings charm. Allows you to personalize your computer: Change your account picture, specify the background and color of your Start screen, and more. |
|  | | Mutes or restores speaker sound. |
|  | | Decreases speaker volume incrementally as long as you hold down the key. |





| Icon | Key | Description |
|---|-----|---|
|  | | Increases speaker volume incrementally as long as you hold down the key. |
|  | | <p>Initiates Sleep, which saves your information in the system. The display and other system components turn off and power is conserved.</p> <p>To exit Sleep, briefly press the power button.</p> <p>CAUTION: To reduce the risk of information loss, save your work before initiating Sleep.</p> <p>WARNING! If a critical battery level occurs while the computer is in the Sleep state, the computer initiates Hibernation and the information stored is saved to the hard drive.</p> |

Using Microsoft Windows 8 shortcut keys

Microsoft Windows 8 provides shortcuts to perform actions quickly. Several shortcuts will help you with Windows 8 functions. Press the Windows logo key  in combination with the key to perform the action.

For additional information on Windows 8 shortcut keys, go to **Help and Support**. From the Start screen, type `h`, and then select **Help and Support**.

Shortcut Keys

| Shortcut key | Key | Description |
|---|--------------------|---|
|  | | Returns you to the Start screen from an open app or the Windows desktop. Pressing the key again returns you to the previous screen. |
|  | + <code>c</code> | Opens the charms. |
|  | + <code>d</code> | Opens the Windows desktop. |
|  | + <code>tab</code> | <p>Switches between open apps.</p> <p>NOTE: Continue to press this key combination until the app you want displays.</p> |
| <code>alt</code> | + <code>f4</code> | Closes an active app. |

Using the integrated numeric keypad

The computer includes an external wireless keyboard that includes a numeric keypad.

| Component | Description |
|---------------------------|--|
| num lock key | <p>Controls the function of the integrated numeric keypad. Press the key to alternate between the standard numeric function found on an external keypad (this function is turned on at the factory) and the navigational function (indicated by the directional arrows on the keys).</p> <p>NOTE: The keypad function that is active when the computer is turned off is reinstated when the computer is turned back on.</p> |
| Integrated numeric keypad | <p>Set at the factory to function like an external numeric keypad. To alternate between this numeric function and the navigational function (indicated by the directional arrows on the keys), press the num lock key.</p> |

6 Managing power

Initiating Sleep and Hibernation

Windows has two power-saving states, Sleep and Hibernation.

- Sleep—The Sleep state is automatically initiated after a period of inactivity. Your work is saved to memory, allowing you to resume working very quickly. You can also initiate Sleep manually. For more information, see [Manually initiating and exiting Sleep on page 25](#).
- Hibernation—The Hibernation state is automatically initiated if the computer is in the Sleep state for an extended period. Hibernation puts your open documents and programs on your hard drive, and then turns off your computer.

 **NOTE:** You can manually initiate Hibernation. See [Manually initiating and exiting Sleep on page 25](#) and [Manually initiating and exiting Hibernation on page 26](#).

 **CAUTION:** To reduce the risk of possible audio and video degradation, loss of audio or video playback, or loss of information, do not initiate Sleep while reading from or writing to a disc or an external media card.

 **NOTE:** You cannot connect to a network or perform any computer functions while the computer is in the Sleep state or in Hibernation.

Intel Rapid Start Technology (select models only)

For select models, the Intel Rapid Start Technology (RST) feature is enabled by default. Rapid Start Technology allows your computer to resume quickly from inactivity.

Rapid Start Technology manages your power-saving options as follows:

- Sleep—Rapid Start Technology allows you to select the Sleep state. To exit from Sleep, press any key, activate the TouchPad, or briefly press the power button.
- Hibernation—Rapid Start Technology initiates Hibernation after a period of computer inactivity while the computer is in the Sleep or when the battery reaches a critical level. After Hibernation is initiated, press the power button to resume your work.

 **NOTE:** Rapid Start Technology can be disabled in Setup Utility (BIOS). If you want to be able to initiate Hibernation yourself, you must enable user-initiated Hibernation using Power Options. See [Manually initiating and exiting Hibernation on page 26](#).

Manually initiating and exiting Sleep

- ▲ To initiate Sleep, from the Start screen, point to the far-right upper or lower corner of the screen to display the charms. Click **Settings**, click the **Power** icon, and then select **Sleep**.

To exit Sleep:

- Briefly press the power button.
- Press a key on the keyboard.

When the computer exits Sleep, the power lights turn on and your work returns to the screen.



NOTE: If you have set a password to be required on wakeup, you must enter your Windows password before your work will return to the screen.

Manually initiating and exiting Hibernation

You can enable user-initiated Hibernation and change other power settings and timeouts using Power Options in Control Panel.

1. From the Start screen, type `power`, select **Settings**, and then select **Power Options**.
2. In the left pane, select **Choose what the power button does**.
3. Select **Change Settings that are currently unavailable**.
4. In the **When I press the power button** area, select **Hibernate**.
5. Click **Save changes**.

To exit Hibernation, briefly press the power button.

When the computer exits Hibernation, the power lights turn on and your work returns to the screen. If you have set a password to be required on wakeup, you must enter your Windows password before your work will return to the screen.

Setting password protection on wakeup

To set the computer to prompt for a password when the computer exits Sleep or Hibernation, follow these steps:

1. From the Start screen, type `power`, select **Settings**, and then select **Power Options**.
2. In the left pane, select **Require a password on wakeup**.
3. Select **Change Settings that are currently unavailable**.
4. Select **Require a password (recommended)**.



NOTE: If you need to create a user account password or change your current user account password, click **Create or change your user account password**, and then follow the on-screen instructions. If you do not need to create or change a user account password, go to step 5.

5. Click **Save changes**.

HP CoolSense (select models only)

HP CoolSense  automatically detects when the computer is not in a stationary position and adjusts performance and fan settings to keep the surface temperature of your computer at the optimum level of comfort.

When HP CoolSense is off, the position of the computer is not detected and the performance and fan options remain at the factory setting. As a result, the surface temperature of the computer may be higher than it would be with HP CoolSense on.

To turn CoolSense off or on, follow these steps:

- ▲ From the Start screen, type `cool`, select **Settings**, and then select **HP CoolSense**.

Refreshing your software content with Intel Smart Connect Technology (select models only)

When the computer is in the Sleep state, Intel® Smart Connect Technology periodically causes the computer to exit Sleep. If a network connection is available, Smart Connect updates open apps such as your email inboxes, social network sites, and news pages and then returns the computer to the Sleep state. Smart Connect also syncs content that you have created offline, such as emails. When the computer exits Sleep, you have immediate access to your updated information.

- ▲ To enable this feature or manually adjust the settings, from the **Start** screen, type `smart`, and then select Intel® Smart Connect Technology.

Shutting down (turning off) the computer

 **CAUTION:** Unsaved information is lost when the computer shuts down.

The Shut down command closes all open programs, including the operating system, and then turns off the computer.

Shut down the computer under any of the following conditions:

- When you need to access components inside the computer
- When you are connecting an external hardware device to a port other than a USB or video port
- When the computer will be unused and disconnected from external power for an extended period

Although you can Shut down the computer with the power button, the recommended procedure is to use the turn off command, as follows:

 **NOTE:** If the computer is in the Sleep state or in Hibernation, you must first exit Sleep or Hibernation before shutdown is possible.

1. Save your work and close all open programs.
2. From the Start screen, point to the far-right upper or lower corner of the screen to display charms, and then click **Settings**.
3. Click the **Power** icon, and then click **Shut down**.

If the computer is unresponsive and you are unable to use the preceding shutdown procedures, try the following emergency procedures in the sequence provided:

- Press `ctrl+alt+delete`. Click the **Power** icon in the lower-right corner of the screen, and then click **Shut Down**.
- Press and hold the power button for at least 5 seconds.
- Disconnect the computer from external power.

7 Managing and sharing information

Drives are digital storage devices or solid-state drives that help you store, manage, share, and access information. Your computer has an internal hard drive that stores your personal files and your computer's software and operating system. For added capacity or functionality, connect an external drive (purchased separately), such as an optical drive or hard drive.

To quickly transfer information, connect a Universal Serial Bus (USB) flash drive to the USB port on your computer, or insert the memory card from your phone or camera into the memory card reader.



NOTE: For more information about required software and drivers, or to learn which computer port to use, see the manufacturer's instructions.

Using a USB device

Most computers have at least one USB port, because this versatile interface allows you to connect to numerous kinds of external devices to your computer.

Your computer may have more than one type of USB port. See [Getting to know your computer on page 4](#) for the types of USB ports on this computer. Be sure to purchase devices that are compatible with your computer.

Connecting a USB device

CAUTION: To reduce the risk of damage to a USB connector, use minimal force to connect the device.

- ▲ Connect the USB cable for the device to the USB port.



A sound indicates that the device has been detected.

NOTE: The first time you connect a USB device, a message displays on the Windows desktop and an icon in the notification area lets you know that the device is recognized by the computer.

Removing a USB device

CAUTION: To reduce the risk of damage to a USB connector, do not pull on the cable to remove the USB device.

CAUTION: To reduce the risk of loss of information or an unresponsive system, use the following procedure to safely remove the USB device.

1. Save your information and close all programs associated with the device.
2. From the Windows desktop, click the hardware icon in the notification area, at the far right of the taskbar. A message, **Safely Remove Hardware and Eject Media** displays.
3. Follow the on-screen instructions.

Inserting and removing a memory card

To insert a memory card:

⚠ CAUTION: To reduce the risk of damage to the memory card connectors, use minimal force to insert a memory card.

1. Hold the card label-side up, with the connectors facing the computer.
2. Insert the card into the memory card reader, and then press in on the card until it is firmly seated.

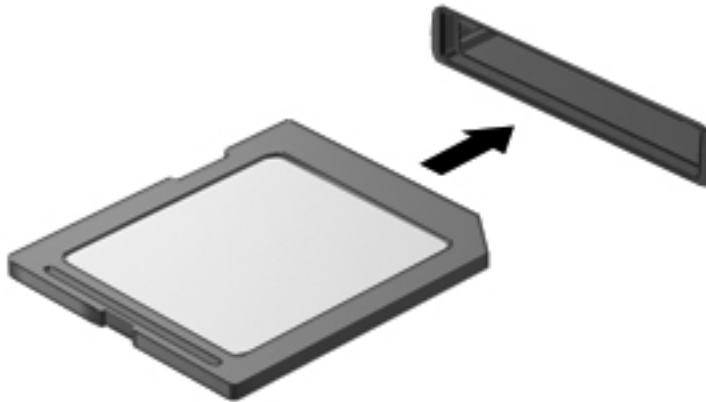

A sound indicates that the device has been detected.

To remove a memory card:

1. Save your information and close all programs associated with the card.
2. From the Windows desktop, click the remove hardware icon in the notification area, at the far right of the taskbar. Then, follow the on-screen instructions.
3. Press in on the card (1), and then remove it from the slot (2).

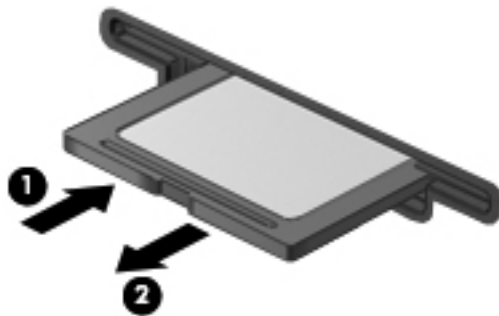

8 Maintaining peak performance

Keep your computer at peak operating performance using the practices and tools described in this chapter. Start with routine maintenance, keep the equipment clean, and regularly update software. Also pay attention to important security issues, including passwords, virus protection, and anti-theft measures. Finally, find out how to access your system settings when you need to contact support or run diagnostics on your computer system.

Performing routine maintenance

Using Disk Cleanup

Disk Cleanup searches the hard drive for unnecessary files that you can safely delete to free up disk space and help the computer run more efficiently.

To run Disk Cleanup:

1. From the Start screen, type `disk`.
2. Click **Settings**, and then select **Free up disk space by deleting unnecessary files**.
3. Follow the on-screen instructions.

Using Disk Defragmenter

As you use your computer over time, the files on the hard drive become fragmented. Because of this, the hard drive works harder to locate files, and the computer slows down. Disk Defragmenter consolidates and reorganizes the fragmented files on the hard drive so that the system can run more efficiently.

Depending on the size of your hard drive and the number of fragmented files, Disk Defragmenter may need more than an hour to complete the task.

To run Disk Defragmenter:

1. From the Start screen, type `disk`.
2. Click **Settings**, and then select **Defragment and optimize your drives**.

Updating programs and drivers

HP recommends that you update your programs and drivers on a regular basis. Updates can resolve issues and bring new features and options to your computer.

Go to the HP support website to download the latest versions of HP programs and drivers. For U.S. support, go to <http://www.hp.com/go/contactHP>. For worldwide support, go to http://welcome.hp.com/country/us/en/wwcontact_us.html. At this location, you can also register to receive automatic notifications when updates become available.

Cleaning your computer

Cleaning products

Use the following products to safely clean your computer:

- Dimethyl benzyl ammonium chloride 0.3 percent maximum concentration (For example: Disposable wipes come in a variety of brand names.)
- Alcohol-free glass cleaning fluid
- Water with mild soap solution
- Dry microfiber cleaning cloth or a chamois (static-free cloth without oil)
- Static-free cloth wipes

 **CAUTION:** Avoid the following cleaning products:

Strong solvents, such as alcohol, acetone, ammonium chloride, methylene chloride, and hydrocarbons, which can permanently damage the surface of the computer.

Fibrous materials, such as paper towels, which can scratch the computer. Over time, dirt particles and cleaning agents can get trapped in the scratches.

Cleaning procedures

Follow the procedures in this section to safely clean your computer.

 **WARNING!** To prevent electric shock or damage to components, do not attempt to clean your computer while it is turned on:

Turn off the computer.

Disconnect external power.

Disconnect all powered external devices.

 **CAUTION:** Do not spray cleaning agents or liquids directly on any computer surface. Liquids dripped on the surface can permanently damage internal components.

Cleaning the display

Gently wipe the display using a soft, lint-free cloth moistened with an *alcohol-free* glass cleaner. Be sure that the display is dry before closing the display.

Cleaning the sides and cover

To clean the sides and cover, use a soft microfiber cloth or chamois moistened with one of the cleaning solutions listed previously or use an acceptable I disposable wipe.

 **NOTE:** When cleaning the cover of the computer, use a circular motion to aid in removing dirt and debris.

Cleaning the keyboard

 **WARNING!** To reduce the risk of electric shock or damage to internal components, do not use a vacuum cleaner attachment to clean the keyboard. A vacuum cleaner can deposit household debris on the keyboard surface.

⚠ CAUTION: When cleaning the keyboard, do not let liquids drip between the keys. This can permanently damage internal components.

- To clean and disinfect the keyboard, use a soft microfiber cloth or chamois moistened with one of the cleaning solutions listed previously or use an acceptable disposable wipe.
- To prevent keys from sticking and to remove dust, lint, and particles from the keyboard, use a can of compressed air with a straw extension.

Using security measures

A password is a group of characters that you choose to secure your computer information and to protect online transactions. Several types of passwords can be set. For example, when you set up your computer for the first time, you were asked to create a user password to secure your computer. Additional passwords can be set in Windows or in the HP Setup Utility (BIOS) that is preinstalled on your computer.

You may find it helpful to use the same password for a Setup Utility (BIOS) feature and for a Windows security feature.

Use the following tips for creating and saving passwords:

- To reduce the risk of being locked out of the computer, record each password and store it in a secure place away from the computer. Do not store passwords in a file on the computer.
- When creating passwords, follow requirements set by the program.
- Change your passwords at least every three months.
- An ideal password is long and has letters, punctuation, symbols, and numbers.
- Before you send your computer for service, back up your files, delete confidential files, and then remove all password settings.

For additional information about Windows passwords, such as screen-saver passwords, from the Start screen, type `support`, and then select the **HP Support Assistant** app.

Setting Windows passwords

| Password | Function |
|------------------------|---|
| User password | Protects access to a Windows user account. |
| Administrator password | Protects administrator-level access to computer contents. NOTE: This password cannot be used to access Setup Utility (BIOS) contents. |

Setting Setup Utility (BIOS) passwords

| Password | Function |
|------------------------|--|
| Administrator password | <ul style="list-style-type: none">• Must be entered each time you access Setup Utility (BIOS).• If you forget your administrator password, you cannot access Setup Utility (BIOS). <p>NOTE: The administrator password can be used in place of the power-on password.</p> <p>NOTE: Your administrator password is not interchangeable with an administrator password set in Windows, nor is it revealed as it is set, entered, changed, or deleted.</p> <p>NOTE: If you enter the power-on password at the first password check, you must enter the administrator password to access Setup Utility (BIOS).</p> |
| Power-on password | <ul style="list-style-type: none">• Must be entered each time you turn on or restart the computer.• If you forget your power-on password, you cannot turn on or restart the computer. <p>NOTE: The administrator password can be used in place of the power-on password.</p> <p>NOTE: A power-on password is not revealed as it is set, entered, changed, or deleted.</p> |

To set, change, or delete an administrator or power-on password in Setup Utility (BIOS):

1. To start Setup Utility (BIOS), turn on or restart the computer, quickly press **esc**, and then press **f10**.
2. Use the arrow keys to select **Security**, and then follow the on-screen instructions.

Your changes take effect when the computer restarts.

Using Internet security software

When you use your computer to access email, a network, or the Internet, you expose your computer to viruses, spyware, and other online threats. To help protect your computer, Internet security software that includes antivirus and firewall features is preinstalled on your computer.

- ▲ To access Norton Internet Security, from the Start screen, type **n**, and then select **Norton Internet Security**.

For more information about protecting your computer from Internet threats, go to Help and Support. From the Start screen, type **h**, and then select **Help and Support**.

Installing software updates

Installing Windows updates

Updates to the operating system and other software may have become available after the computer left the factory. Microsoft sends out alerts regarding critical updates. To protect the computer from security breaches and computer viruses, install all critical updates from Microsoft as soon as you receive an alert.

To be sure that all available updates are installed on the computer, observe these guidelines:

- Run Windows Update as soon as possible after you set up your computer. From the Start screen, type **u**, select **Settings**, and then select **Windows Update**.
- Enable automatic Windows Update thereafter.

Updating software

HP recommends that you regularly update the software and drivers that were originally installed on your computer. To download the latest versions, go to <http://www.hp.com/support>. At this location, you can also register to receive automatic update notifications when updates become available.

If you have installed software from other companies, regularly update the software to correct security problems and improve the performance of the software.

9 Using Setup Utility (BIOS) and HP PC Hardware Diagnostics (UEFI)

Setup Utility, or Basic Input/Output System (BIOS), controls communication between all the input and output devices on the system (such as disk drives, display, keyboard, mouse, and printer). Setup Utility (BIOS) includes settings for the types of devices installed, the startup sequence of the computer, and the amount of system and extended memory.

Starting Setup Utility (BIOS)

To start Setup Utility (BIOS), turn on or restart the computer, quickly press **esc**, and then press **f10**.

Information about how to navigate in Setup Utility (BIOS) is located at the bottom of the screen.



NOTE: Use extreme care when making changes in Setup Utility (BIOS). Errors can prevent the computer from operating properly.

Updating the BIOS

Updated versions of the BIOS may be available on the HP website.

Most BIOS updates on the HP website are packaged in compressed files called *SoftPaqs*.

Some download packages contain a file named *Readme.txt*, which contains information regarding installing and troubleshooting the file.

Determining the BIOS version

To determine whether available BIOS updates contain later BIOS versions than those currently installed on the computer, you need to know the version of the system BIOS currently installed.

BIOS version information (also known as *ROM date* and *System BIOS*) can be revealed by pressing **fn+esc** (if you are already in Windows) or by using Setup Utility (BIOS).

1. Start Setup Utility (BIOS) (see [Starting Setup Utility \(BIOS\) on page 36](#)).
2. Use the arrow keys to select **Main**.
3. To exit Setup Utility (BIOS) without saving your changes, use the arrow keys to select **Exit**, select **Exit Discarding Changes**, and then press **enter**.
4. Click **Yes**.

Downloading a BIOS update

 **CAUTION:** To reduce the risk of damage to the computer or an unsuccessful installation, download and install a BIOS update only when the computer is connected to reliable external power using the AC adapter. Do not download or install a BIOS update while the computer is running on battery power, docked in an optional docking device, or connected to an optional power source. During the download and installation, follow these instructions:

Do not disconnect power from the computer by unplugging the power cord from the AC outlet.

Do not shut down the computer or initiate Sleep.

Do not insert, remove, connect, or disconnect any device, cable, or cord.

1. From the Start screen, type `support`, and then select the **HP Support Assistant** app.
2. Click **Updates and tune-ups**, and then click **Check for HP updates now**.
3. Follow the on-screen instructions.
4. At the download area, follow these steps:
 - a. Identify the most recent BIOS update and compare it to the BIOS version currently installed on your computer. If the update is more recent than your BIOS, make a note of the date, name, or other identifier. You may need this information to locate the update later, after it has been downloaded to your hard drive.
 - b. Follow the on-screen instructions to download your selection to the hard drive.

If the update is more recent than your BIOS, make a note of the path to the location on your hard drive where the BIOS update is downloaded. You will need to access this path when you are ready to install the update.

 **NOTE:** If you connect your computer to a network, consult the network administrator before installing any software updates, especially system BIOS updates.

BIOS installation procedures vary. Follow any instructions that are revealed on the screen after the download is complete. If no instructions are revealed, follow these steps:

1. From the Start screen, type `e`, and then select **File Explorer**.
2. Click your hard drive designation. The hard drive designation is typically Local Disk (C:).
3. Using the hard drive path you recorded earlier, open the folder on your hard drive that contains the update.
4. Double-click the file that has an `.exe` extension (for example, `filename.exe`).

The BIOS installation begins.
5. Complete the installation by following the on-screen instructions.

 **NOTE:** After a message on the screen reports a successful installation, you can delete the downloaded file from your hard drive.

Using HP PC Hardware Diagnostics (UEFI)

HP PC Hardware Diagnostics is a Unified Extensible Firmware Interface (UEFI) that allows you to run diagnostic tests to determine whether the computer hardware is functioning properly. The tool runs outside the operating system so that it can isolate hardware failures from issues that are caused by the operating system or other software components.

To start HP PC Hardware Diagnostics UEFI:

1. Turn on or restart the computer, quickly press **esc**, and then press **f2**.

The BIOS searches three places for the HP PC Hardware Diagnostics (UEFI) tools in the following order:

- a. Connected USB drive



NOTE: To download the HP PC Hardware Diagnostics (UEFI) tool to a USB drive, see [Downloading HP PC Hardware Diagnostics \(UEFI\) to a USB device on page 38](#).

- b. Hard drive
- c. BIOS

2. Click the type of diagnostic test you want to run, and then follow the on-screen instructions.



NOTE: If you need to stop a diagnostic test, press **esc**.

Downloading HP PC Hardware Diagnostics (UEFI) to a USB device



NOTE: The HP PC Hardware Diagnostics (UEFI) download instructions are provided in English only.

1. Go to <http://www.hp.com>.
2. Click **Support & Drivers**, and then click the **Drivers & Software** tab.
3. Enter the product name in the text box, and then click **Search**.
4. Select your computer model, and then select your operating system.
5. In the **Diagnostic** section, click **HP UEFI Support Environment**.

– or –

Click **Download**, and then select **Run**.

10 Backing up, restoring, and recovering

Your computer includes tools provided by HP and Windows to help you safeguard your information and retrieve it if you ever need to. These tools will help you return your computer to a proper working state or even back to the original factory state, all with simple steps.

This chapter provides information about the following processes:

- Creating recovery media and backups
- Restoring and recovering your system



NOTE: This chapter describes an overview of backing up, restoring and recovering options. For more details about the tools provided, see Help and Support. From the Start screen, type **h**, and then select **Help and Support**.

Creating recovery media and backups

Recovery after a system failure is only as good as your most recent backup.

1. After you successfully set up the computer, create HP Recovery media. This step creates a backup of the HP Recovery partition on the computer. The backup can be used to reinstall the original operating system in cases where the hard drive is corrupted or has been replaced.

HP Recovery media you create will provide the following recovery options:

- System Recovery—Reinstalls the original operating system and the programs that were installed at the factory.
- Minimized Image Recovery—Reinstalls the operating system and all hardware-related drivers and software, but not other software applications.
- Factory Reset—Restores the computer to its original factory state by deleting all information from the hard drive and re-creating the partitions. Then it reinstalls the operating system and the software that was installed at the factory.

See [Creating HP Recovery media on page 40](#).

2. As you add hardware and software programs, create system restore points. A system restore point is a snapshot of certain hard drive contents saved by Windows System Restore at a specific time. A system restore point contains information that Windows uses, such as registry settings. Windows creates a system restore point for you automatically during a Windows update and during other system maintenance (such as a software update, security scanning, or system diagnostics). You can also manually create a system restore point at any time. For more information and steps for creating specific system restore points, see Help and Support. From the Start screen, type **h**, and then select **Help and Support**.
3. As you add photos, video, music, and other personal files, create a backup of your personal information. Windows File History can be set to regularly and automatically back up files from libraries, desktop, contacts, and favorites. If files are accidentally deleted from the hard drive and they can no longer be restored from the Recycle Bin, or if files become corrupted, you can restore the files that you backed up using File History. Restoring files is also useful if you ever

choose to reset the computer by reinstalling Windows or choose to recover using HP Recovery Manager.

 **NOTE:** File History is not enabled by default, so you must turn it on.

For more information and steps for enabling Windows File History, see Help and Support. From the Start screen, type `h`, and then select **Help and Support**.

Creating HP Recovery media

HP Recovery Manager is a software program that offers a way to create recovery media after you successfully set up the computer. HP Recovery media can be used to perform system recovery if the hard drive becomes corrupted. System recovery reinstalls the original operating system and the software programs installed at the factory, and then configures the settings for the programs. HP Recovery media can also be used to customize the system or restore the factory image if you replace the hard drive.

- Only one set of HP Recovery media can be created. Handle these recovery tools carefully, and keep them in a safe place.
- HP Recovery Manager examines the computer and determines the required storage capacity for the blank USB flash drive or the number of blank DVD discs that will be required.
- To create recovery discs, your computer must have an optical drive with DVD writer capability, and you must use only high-quality blank DVD-R, DVD+R, DVD-R DL, or DVD+R DL discs. Do not use rewritable discs such as CD±RW, DVD±RW, double-layer DVD±RW, or BD-RE (rewritable Blu-ray) discs; they are not compatible with HP Recovery Manager software. Or instead you can use a high-quality blank USB flash drive.
- If your computer does not include an integrated optical drive with DVD writer capability, but you would like to create DVD recovery media, you can use an external optical drive (purchased separately) to create recovery discs, or you can obtain recovery discs for your computer from the HP website. For U.S. support, go to <http://www.hp.com/go/contactHP>. For worldwide support, go to http://welcome.hp.com/country/us/en/wwwcontact_us.html. If you use an external optical drive, it must be connected directly to a USB port on the computer; the drive cannot be connected to a USB port on an external device, such as a USB hub.
- Be sure that the computer is connected to AC power before you begin creating the recovery media.
- The creation process can take up to an hour or more. Do not interrupt the creation process.
- If necessary, you can exit the program before you have finished creating all of the recovery DVDs. HP Recovery Manager will finish burning the current DVD. The next time you start HP Recovery Manager, you will be prompted to continue, and the remaining discs will be burned.

To create HP Recovery media:

1. From the Start screen, type `recovery`, and then select **HP Recovery Manager**.
2. Select **Recovery Media Creation**, and then follow the on-screen instructions.

If you ever need to recover the system, see [Recovering using HP Recovery Manager on page 43](#).

Restore and recovery

There are several options for recovering your system. Choose the method that best matches your situation and level of expertise:

- If you need to restore your personal files and data, you can use Windows File History to restore your information from the backups you created. For more information and steps for using File History, see Help and Support. From the Start screen, type **h**, and then select **Help and Support**.
- If you need to correct a problem with a preinstalled application or driver, use the Drivers and Applications Reinstall option of HP Recovery Manager to reinstall the individual application or driver.

From the Start screen, type *recovery*, select **HP Recovery Manager**, select **Drivers and Applications Reinstall**, and then follow the on-screen instructions.

- If you want to restore the system to a previous state without losing any personal information, Windows System Restore is an option. System Restore allows you to restore without the requirements of Windows Refresh or a reinstallation. Windows creates system restore points automatically during a Windows update and other system maintenance events. Even if you did not manually create a restore point, you can choose to restore to an automatically created restore point. For more information and steps for using Windows System Restore, see Help and Support. From the Start screen, type **h**, and then select **Help and Support**.
- If you want a quick and easy way to recover the system without losing your personal information, settings, or apps that came preinstalled on your computer or were purchased from the Windows Store, consider using Windows Refresh. This option does not require backing up data to another drive. See [Using Windows Refresh for quick and easy recovery on page 42](#).
- If you want to reset your computer to its original state, Windows provides an easy way to remove all personal data, apps, and settings, and reinstall Windows.

For more information, see [Remove everything and reinstall Windows on page 42](#).

- If you want to reset your computer using a minimized image, you can choose the HP Minimized Image Recovery option from the HP Recovery partition (select models only) or HP Recovery media. Minimized Image Recovery installs only drivers and hardware-enabling applications. Other applications included in the image continue to be available for installation through the Drivers and Applications Reinstall option in HP Recovery Manager.

For more information, see [Recovering using HP Recovery Manager on page 43](#).

- If you want to recover the computer's original factory partitioning and content, you can choose the System Recovery option from the HP Recovery partition (select models only) or use the HP Recovery media that you have created. For more information, see [Recovering using HP Recovery Manager on page 43](#). If you have not already created recovery media, see [Creating HP Recovery media on page 40](#).
- If you have replaced the hard drive, you can use the Factory Reset option of HP Recovery media to restore the factory image to the replacement drive. For more information, see [Recovering using HP Recovery Manager on page 43](#).
- If you wish to remove the recovery partition to reclaim hard drive space, HP Recovery Manager offers the Remove Recovery Partition option.

For more information, see [Removing the HP Recovery partition on page 44](#).

Using Windows Refresh for quick and easy recovery

When your computer is not working properly and you need to regain system stability, the Windows Refresh option allows you to start fresh and keep what is important to you.

 **IMPORTANT:** Refresh removes any traditional applications that were not originally installed on the system at the factory. Any Windows 8 apps that came preinstalled on your computer and any that were purchased from the Windows Store will be saved.

 **NOTE:** During Refresh, a list of removed traditional applications will be saved so that you have a quick way to see what you might need to reinstall. See Help and Support for instructions on reinstalling traditional applications. From the Start screen, type **h**, and then select **Help and Support**.

 **NOTE:** You may be prompted for your permission or password when using Refresh. See Help and Support for more information. From the Start screen, type **h**, and then select **Help and Support**.

To start Refresh:

1. From the Start screen, point to the upper-right or lower-right corner of the screen to reveal the charms.
2. Click **Settings**.
3. Click **Change PC settings** in the bottom-right corner of the screen, and then select **General** from the PC settings screen.
4. Scroll the right-side choices down to display **Refresh your PC without affecting your files**.
5. Under **Refresh your PC without affecting your files**, select **Get started**, and then follow the on-screen instructions.

Remove everything and reinstall Windows

Sometimes you want to perform detailed reformatting of your computer, or you want to remove personal information before you give away or recycle your computer. The process described in this section provides a speedy, simple way to return the computer to its original state. This option removes all personal data, apps, and settings from your computer, and reinstalls Windows.

 **IMPORTANT:** This option does not provide backups of your information. Before using this option, back up any personal information you wish to retain.

You can initiate this option by using the **f11** key or from the Start screen.

To use the **f11** key:

1. Press **f11** while the computer boots.
– or –
Press and hold **f11** as you press the power button.
2. Choose your keyboard layout.
3. Select **Troubleshoot** from the boot options menu.
4. Select **Reset your PC**, and then follow the on-screen instructions.

To use the Start screen:

1. From the Start screen, point to the upper-right or lower-right corner of the screen to reveal the charms.
2. Click **Settings**.

3. Click **Change PC settings** in the bottom-right corner of the screen, and then select **General** from the PC settings screen.
4. Scroll the right-side choices down to display **Remove everything and reinstall Windows**.
5. Under **Remove everything and reinstall Windows**, select **Get started**, and follow the on-screen instructions.

Recovering using HP Recovery Manager

HP Recovery Manager software allows you to recover the computer to its original factory state by using the HP Recovery media that you created or by using the HP Recovery partition (select models only). If you have not already created recovery media, see [Creating HP Recovery media on page 40](#).

Using HP Recovery media, you can choose from one of the following recovery options:

- System Recovery—Reinstalls the original operating system, and then configures the settings for the programs that were installed at the factory.
- Minimized Image Recovery (select models only)—Reinstalls the operating system and all hardware-related drivers and software, but not other software applications.
- Factory Reset—Restores the computer to its original factory state by deleting all information from the hard drive and re-creating the partitions. Then it reinstalls the operating system and the software that was installed at the factory.

The HP Recovery partition (select models only) allows System Recovery and Minimized Image Recovery.

What you need to know

- HP Recovery Manager recovers only software that was installed at the factory. For software not provided with this computer, you must either download the software from the manufacturer's website or reinstall the software from the media provided by the manufacturer.
- Recovery through HP Recovery Manager should be used as a final attempt to correct computer issues.
- HP Recovery media must be used if the computer hard drive fails. If you have not already created recovery media, see [Creating HP Recovery media on page 40](#).
- To use the Factory Reset option, you must use HP Recovery media. If you have not already created recovery media, see [Creating HP Recovery media on page 40](#).
- If the HP Recovery media does not work, you can obtain recovery media for your system from the HP website. For U.S. support, go to <http://www.hp.com/go/contactHP>. For worldwide support, go to http://welcome.hp.com/country/us/en/wwwcontact_us.html.



IMPORTANT: HP Recovery Manager does not automatically provide backups of your personal data. Before beginning recovery, back up any personal data you wish to retain.

Using the HP Recovery partition (select models only)

The HP Recovery partition (select models only) allows you to perform a system recovery or minimized image recovery without the need for recovery discs or a recovery USB flash drive. This type of recovery can only be used if the hard drive is still working.

To start HP Recovery Manager from the HP Recovery partition:

1. Press **f11** while the computer boots.
– or –
Press and hold **f11** as you press the power button.
2. Choose your keyboard layout.
3. Select **Troubleshoot** from the boot options menu.
4. Select **Recovery Manager**, and follow the on-screen instructions.

Using HP Recovery media to recover

You can use HP Recovery media to recover the original system. This method can be used if your system does not have an HP Recovery partition or if the hard drive is not working properly.

1. If possible, back up all personal files.
2. Insert the first HP Recovery disc you created into the optical drive on your computer or into an optional external optical drive, and then restart the computer.

– or –

Insert the HP Recovery USB flash drive you created into a USB port on your computer, and then restart the computer.

 **NOTE:** If the computer does not automatically restart in HP Recovery Manager, change the computer boot order. See [Changing the computer boot order on page 44](#).

3. Follow the on-screen instructions.

Changing the computer boot order

If computer does not restart in HP Recovery Manager, you can change the computer boot order, which is the order of devices listed in BIOS where the computer looks for startup information. You can change the selection for an optical drive or a USB flash drive.

To change the boot order:

1. Insert the HP Recovery media you created.
2. Restart the computer, quickly press **esc**, and then press **f9** for boot options.
3. Select the optical drive or USB flash drive you want to boot from.
4. Follow the on-screen instructions.

Removing the HP Recovery partition

HP Recovery Manager software allows you to remove the HP Recovery partition to free up hard drive space.

 **IMPORTANT:** After you remove the HP Recovery partition, you can no longer use the Windows Refresh option, the Windows option to remove everything and reinstall Windows, or the HP Recovery Manager option. So before you remove the Recovery partition, create HP Recovery media; see [Creating HP Recovery media on page 40](#).

Follow these steps to remove the HP Recovery partition:

1. From the Start screen, type `recovery`, and then select **HP Recovery Manager**.
2. Select **Remove Recovery Partition**, and then follow the on-screen instructions.

11 Troubleshooting

Wireless connection problems

Some possible causes for wireless connection problems include the following:

- Wireless device is not turned on.
- Wireless device is not installed correctly or has been disabled.
- Wireless device encountered interference from other devices.
- Wireless device or router hardware has failed.

Cannot connect to a WLAN

If you have a problem connecting to a WLAN, confirm that the integrated WLAN device is turned on and properly installed on your computer.

1. Be sure that the wireless device is turned on.
2. Then try connecting to the WLAN again.

If you are still unable to connect, follow the steps below.

1. From the Start screen, type **c**, and then select **Control Panel**.
2. Select **System and Security**, and then in the **System** area, click **Device Manager**.
3. Click the arrow next to **Network adapters** to expand the list and show all adapters.
4. Identify the WLAN device from the Network adapters list. The listing for a WLAN device may include the term *wireless*, *wireless LAN*, *WLAN*, or *802.11*.

If no WLAN device is listed, either your computer does not have an integrated WLAN device, or the driver for the WLAN device is not properly installed.

For more information about troubleshooting WLANs, see the website links provided in Help and Support.

Cannot connect to a preferred network

You may not be able to connect to a preferred network because it is a security-enabled WLAN. You must have the security code to connect to this type of WLAN. See the next section for additional information.

If entering a security code is not the problem, you may have a corrupted WLAN connection. Many times, Windows can automatically repair a corrupted WLAN connection.

- If there is a network status icon in the notification area, at the far right of the taskbar, right-click the icon, and then click **Troubleshoot problems**.

Windows resets your network device and attempts to reconnect to one of the preferred networks.

- If there is no network status icon in the notification area, follow these steps:
 1. From the Start screen, type **c**, and then select **Control Panel**.
 2. Select **Network and Internet**, and then select **Network and Sharing Center**.
 3. Select **Troubleshoot problems**, and then select the network you want to repair.

Current network security codes are unavailable

If you are prompted for a security code (or network key) or a name (SSID) when connecting to a WLAN, the network is protected by security. The SSID and security code are alphanumeric codes that you enter into your computer to identify your computer to the network. You must have the current codes to connect to a secure network.

- For a network connected to your personal wireless router, review the router user guide for instructions on setting up the same codes on both the router and the WLAN device.
- For a private network, such as a network in an office or at a public Internet chat room, contact the network administrator to obtain the codes, and then enter the codes when you are prompted to do so.

Some networks change the SSID or network keys used in their routers or access points on a regular basis to improve security. You must change the corresponding code in your computer accordingly.

If you are provided with a new wireless network key and SSID for a network, and if you have previously connected to that network, follow the steps below to reconnect to the network:

1. From the Windows desktop, click the network status icon in the notification area, at the far right of the taskbar.

A list showing the available WLANs is displayed. If you are in a hotspot where several WLANs are active, several will be displayed.

2. Right-click the network, and then click **Properties**.



NOTE: If the network you want is not listed, check with the network administrator to be sure that the router or access point is operating.

3. Click the **Security** tab and enter the correct wireless encryption data into the **Network security key** box.
4. Click **OK** to save these settings.

Cannot connect to the wireless router

If you are trying to connect to the wireless router and are unsuccessful, reset the wireless router by removing power from the router for 10 to 15 seconds.

If the computer still cannot connect to a WLAN, restart the wireless router. For details, see the router manufacturer's instructions.

Network status icon is not displayed

If the network status icon is not displayed in the notification area after you configure the WLAN, the software driver is either missing or corrupted. A Windows “Device not Found” error message may also be displayed.

To resolve this problem, get the latest version of the WLAN device software and drivers for your computer from the HP website at <http://www.hp.com>.

1. Open your Internet browser.
2. For U.S. support, go to <http://www.hp.com/go/contactHP>. For worldwide support, go to http://welcome.hp.com/country/us/en/wwcontact_us.html.
3. Click the option for software and driver downloads, and then type your computer model number in the search box.
4. Press **enter**, and then follow the on-screen instructions.



NOTE: If the WLAN device you are using was purchased separately, consult the manufacturer's website for the latest software.

Power problems

Computer will not turn on or start

1. Shut down the computer.
2. Test the AC outlet by connecting a different electrical device to it.
3. Reconnect the computers cables, being sure that the connection from the AC adapter to the computer and the connection from the AC adapter to the AC outlet are secure.
4. Try to turn on the computer.
 - If the power lights turn on, the AC adapter is working properly.
 - If the connections are secure and the power lights remain off, the AC adapter is not functioning and should be replaced.

Contact support for information about obtaining a replacement AC power adapter.

Hard drive error

1. Press the **ctrl+alt+delete** keys simultaneously.
2. Click the **Power** icon, and then click **Restart**.

Or, press and hold the power button on the computer for 5 or more seconds to turn off the computer, and then press the power button to turn on the computer.
3. If Windows opens, immediately back up all important information to an external hard drive.
4. Whether Windows started or not, contact support. Either the hard drive or the system board may need to be replaced.

Computer is not responding

Use the Windows Task Manager to close any programs that are not responding.

1. Press the **ctrl+alt+delete** keys.
2. Click **Task Manager**.
3. Select any program that is not responding, and then click **End Task**.

If closing programs does not work, restart the computer.

1. Press the **ctrl+alt+delete** keys.
2. Click the **Power** icon, and then click **Restart**. Or, press and hold the power button on the computer for 5 or more seconds to turn off the computer, and then press the power button to turn on the computer.

Computer shuts down unexpectedly

- The computer might be in an exceedingly hot environment. Turn it off and let it cool down.
- Be sure that the computer vents are not blocked and that the internal fan is running. See [Getting to know your computer on page 4](#) for the location of the computer vents.

Display problems

The display is blank

- Exit Sleep to redisplay the screen image.
 - Press the power button briefly.
 - Press a key on the keyboard.
 - Press the space bar.
 - Press the **esc** key.
- Press the power button to turn on the computer.

Images on the screen are too large or too small, or the images are fuzzy

Adjust the resolution settings.

1. From the Start screen, type **c**, and then select **Control Panel**.
2. Select **Appearance and Personalization**.
3. Under **Display**, select **Adjust Screen Resolution**.
4. Adjust resolution as necessary, and then click **Apply**.

Keyboard and mouse problems

- Be sure that you are using the keyboard or mouse within range of the receiver.
- Be sure that the mouse is not in Suspend mode, which occurs after 20 minutes of inactivity. Click the left mouse button to reactivate it.

- Replace the batteries in the keyboard and mouse.
- Remove the wireless USB receiver on the bottom of the stand, and then reinsert it. Re-pair the keyboard and mouse to the receiver.

 **NOTE:** The illustrations below may look slightly different from your keyboard and mouse.

 **IMPORTANT:** During these steps, place the keyboard and mouse on the same level as the receiver.

To re-pair the keyboard and mouse:

1. Disconnect the receiver from the USB port on the bottom of the computer stand, and then reconnect it. See [Bottom on page 9](#) for the location of the USB port.



2. Be sure that the mouse is on **(1)**, and then press and hold the Connect button **(2)** for 5 to 10 seconds, until the LED on the receiver lights up or stops flashing. To confirm the connection, move the mouse and check for a response on the screen.



3. After the mouse connection is established, complete the following steps to re-pair the keyboard.

4. Press and hold the Connect button **(3)** for 5 to 10 seconds, until the LED on the receiver lights up or stops flashing.



Audio problems

No sound is produced

- Be sure that you connected powered speakers and that they are turned on.
- Adjust the volume, either on the speakers or through the computer operating system.
- Turn off your computer, and then unplug and reconnect the speakers. Be sure that the speakers are properly connected.
- Unplug headphones if they are connected to your computer (or speaker system).
- If the computer is in the Sleep state, exit Sleep by briefly pressing the power button.
- Check the audio functions.

To check the audio functions on your computer, follow these steps:

1. From the Start screen, type **c**, and then select **Control Panel**.
2. Select **Hardware and Sound**, and then select **Sound**.
3. When the Sound window opens, click the **Sounds** tab. Under **Program Events**, select any sound event, such as a beep or alarm, and click the **Test** button.

You should hear sound through the speakers or through connected headphones.

To check the recording functions on your computer, follow these steps:

1. From the Start screen, type **s**, and then select **Sound Recorder**.
2. Click **Start Recording** and speak into the microphone. Save the file to your Windows desktop.
3. Open a multimedia program and play back the sound.

 **NOTE:** To confirm or change the audio settings on your computer, from the Start screen, type **c**, and then select **Control Panel**. Select **Hardware and Sound**, and then select **Sound**.

Software problems

- Shut down the computer, and then turn it on again.
- Update or reinstall the drivers. See [Updating programs and drivers on page 31](#).
- Refresh or restore your computer. See [Backing up, restoring, and recovering on page 39](#).

12 Specifications

Input power

The power information in this section may be helpful if you plan to travel internationally with the computer.

The computer operates on DC power, which can be supplied by an AC or a DC power source. The AC power source must be rated at 100–240 V, 50–60 Hz. Although the computer can be powered from a standalone DC power source, it should be powered only with an AC adapter or a DC power source supplied and approved by HP for use with this computer.

The computer can operate on DC power within the following specifications. Operating voltage and current varies by platform.

| Input power | Rating |
|-------------------------------------|---|
| Operating voltage and current | 19.5 V dc @ 3.33 A – 65 W |
| DC plug of external HP power supply |  |

 **NOTE:** This product is designed for IT power systems in Norway with phase-to-phase voltage not exceeding 240 V rms.

 **NOTE:** The computer operating voltage and current can be found on the system regulatory label.

Operating specifications

 **NOTE:** To see the electrical ratings, refer to your computer's ratings label, located on the outside of the computer.

| Factor | Metric | U.S. |
|-----------------------|-------------------|-------------------|
| Operating temperature | 5°C to 35°C | 41°F to 95°F |
| Storage temperature | –30°C to 65°C | –22°F to 149°F |
| Operating humidity | 15% to 80% @ 26°C | 15% to 80% @ 78°F |
| Operating altitude | 0 m to 2000 m | 0 ft to 6561 ft |
| Storage altitude | 0 m to 4572 m | 0 ft to 15,000 ft |

13 Electrostatic Discharge

Electrostatic discharge is the release of static electricity when two objects come into contact—for example, the shock you receive when you walk across the carpet and touch a metal door knob.

A discharge of static electricity from fingers or other electrostatic conductors may damage electronic components. To prevent damage to the computer, damage to a drive, or loss of information, observe these precautions:

- If removal or installation instructions direct you to unplug the computer, first be sure that it is properly grounded, and then remove the cover.
- Keep components in their electrostatic-safe containers until you are ready to install them.
- Avoid touching pins, leads, and circuitry. Handle electronic components as little as possible.
- Use nonmagnetic tools.
- Before handling a component, discharge static electricity by touching an unpainted metal surface of the component.
- If you remove a component, place it in an electrostatic-safe container.

If you need more information about static electricity or assistance with component removal or installation, contact support.

Index

A

- AC adapter light, identifying 7
- action keys
 - identifying 21
 - next track or section 22
 - play, pause, resume 22
 - previous 22
 - stop 22
 - using 22
- ambient light sensor, identifying 5
- audio-out (headphone) jacks 6

B

- backing up
 - personal files 40
- backups 39
- Beats Audio 15
- Beats Audio Control Panel 15
- best practices 1
- BIOS
 - determining version 36
 - downloading an update 37
 - updating 36
- Bluetooth device 10
- Bluetooth label 9
- boot order
 - changing HP Recovery Manager 44
- buttons
 - power 8
 - rotate 7
 - stand release 8
 - volume control 5
 - Windows 5

C

- cables, USB 29
- caring for your computer 32
- cleaning
 - display 32
 - keyboard 32
 - procedures 32
 - products 32
 - sides and cover 32
- cleaning your computer 32

- components
 - back 8
 - bottom 8, 9
 - front 4
 - left-side 7
 - right-side 5
- computer reset 42
- connecting to a WLAN 12
- connector, power 7
- corporate WLAN connection 12

D

- deleted files
 - restoring 41
- Disk Cleanup 31
- Disk Defragmenter software 31
- drivers, updating 31

E

- edge swipe gestures 18
- edge—swipe gestures
 - top-edge swipe 20
- electrical ratings 53
- electrostatic discharge 54

F

- fn key, identifying 21
- fun things to do 1

H

- hard drive light, identifying 7
- headphones, connecting 15
- Hibernation
 - exiting 26
 - initiating 26
- high-definition devices,
 - connecting 15
- HP PC Hardware Diagnostics (UEFI)
 - downloading 38
- HP Recovery Manager
 - correcting boot problems 44
 - starting 44

- HP Recovery media
 - creating 40
 - recovery 44
- HP Recovery partition
 - recovery 43
 - removing 44
- hubs 28

I

- input power 53
- installing, critical updates 34
- integrated numeric keypad,
 - identifying 21, 24
- integrated webcam, identifying 5
- Intel Wireless Display 15
- Intel Wireless Music 15
- internal microphones, identifying 4
- Internet connection setup 11
- Internet security software, using 34
- ISP 10

J

- jacks
 - audio-out (headphone) 6

K

- keys
 - fn 21
 - Sleep 21
 - volume 21
 - Windows application 21
 - Windows logo 21

L

- labels
 - Bluetooth 9
 - regulatory 9
 - service 9
 - wireless certification 9
 - WLAN 9
- LAN, connecting 13
- left-edge swipe 19

- lights
 - AC adapter 7
 - ambient light sensor 5
 - hard drive 7
- M**
- maintenance, Disk
 - Defragmenter 31
- memory card reader, identifying 9
- memory card, inserting 30
- minimized image
 - creating 43
- minimized image recovery 43
- N**
- num lock key, identifying 24
- O**
- operating specifications 53
- original system recovery 43
- P**
- passwords
 - Setup Utility (BIOS) 34
 - Windows 33
- pinching touch screen gesture 18
- ports
 - Intel Wireless Display 15
 - Intel Wireless Music 15
 - USB 3.0 7
- power button, identifying 8
- power connector, identifying 7
- product name and number, computer 9
- programs, updating 31
- public WLAN connection 12
- R**
- re-pair, keyboard and mouse 50
- recovery
 - discs 40, 44
 - HP Recovery Manager 43
 - media 44
 - options 39
 - refresh 42
 - starting 44
 - supported discs 40
 - system 43
 - USB flash drive 44
 - using HP Recovery media 40
- recovery media
 - creating 40
 - creating using HP Recovery Manager 40
- recovery partition
 - removing 44
- recycle
 - computer 41, 42
- refresh
 - computer 41
 - recovery 41
 - Windows 42
- regulatory information
 - regulatory label 9
 - wireless certification labels 9
- remove everything and reinstall Windows 42
- reset
 - computer 41, 42
 - steps 42
- restore
 - Windows File History 41
- right-edge swipe 19
- rotate button, identifying 7
- S**
- security, wireless 11
- service label, computer 9
- setting password protection on wakeup 26
- setup of WLAN 11
- Setup Utility (BIOS) passwords 34
- Setup Utility (BIOS), using 36
- shortcut keys, Windows 8 23
- shutdown 27
- Sleep
 - exiting 25
 - initiating 25
- Sleep key, identifying 21
- software
 - CyberLink MediaSuite 15
 - Disk Defragmenter 31
- software updates, installing 34
- software, updating 35
- speakers
 - connecting 14
- speakers, identifying 5
- specifications 53
- stand release button, identifying 8
- supported discs
 - recovery 40
- system recovery 43
- system restore point
 - creating 39
 - restoring 41
- T**
- Touch screen gestures 18, 20
 - edge-swipe gestures 19
 - one-finger slide 16
 - pinching 18
 - rotating 18
 - scrolling 17
 - tapping 17
- Touch screen, using 16
- traveling with the computer 9
- troubleshooting 46
 - audio functions 51
 - computer is not responding 49
 - computer shuts down unexpectedly 49
 - computer will not turn on 48
 - display is blank 49
 - hard drive error 48
 - images on screen problems 49
 - keyboard 49
 - mouse 49
 - re-pair the keyboard and mouse 50
 - software problems 52
 - wireless connection 46
- turning off the computer 27
- U**
- unresponsive system 27
- USB 3.0 ports identifying 7
- USB cable, connecting 29
- USB devices
 - connecting 29
 - description 28
 - removing 29
- USB hubs 28
- V**
- video 15

- volume control button,
 - identifying 5
- volume dial, identifying 14
- volume keys, identifying 21
- volume, adjusting 14

W

- webcam
 - identifying 4
 - using 14
- webcam light, identifying 4
- Windows
 - backup 40
 - File History 40, 41
 - Refresh 41, 42
 - reinstall 41, 42
 - remove everything and reinstall
 - option 42
 - reset 42
 - restoring files 41
 - system restore point 39, 41
- Windows application key,
 - identifying 21
- Windows button, identifying 5
- Windows logo key, identifying 21
- Windows passwords 33
- Windows updates, installing 34
- wired network, connecting 13
- wireless certification label 9
- wireless controls, operating
 - system 10
- wireless light 10
- wireless network (WLAN)
 - connecting 12
 - corporate WLAN connection
 - 12
 - equipment needed 11
 - functional range 12
 - public WLAN connection 12
 - security 11
 - using 11
- wireless router 11
- WLAN device 10
- WLAN label 9

Z

- zooming touch screen gesture 18