

Clarity™ Matrix LCD Video Wall System with G2 Architecture Installation Guide



Copyright © 2014 by Planar Systems, Inc. All rights reserved.

Contents of this publication may not be reproduced in any form without permission of Planar Systems, Inc.

Trademark Credits

Windows™ is a trademark of Microsoft Corp.

Planar's Big Picture™ is a trademark of Planar Systems, Inc.

Planar's EasyAxis™ is a trademark of Planar Systems, Inc.

All other names are trademarks or registered trademarks of their respective companies.

Disclaimer

The information contained in this document is subject to change without notice. Planar Systems, Inc. makes no warranty of any kind with regard to this material. While every precaution has been taken in the preparation of this manual, the Company shall not be liable for errors or omissions contained herein or for incidental or consequential damages in connection with the furnishing, performance, or use of this material.

Warranty and Service Plans

Planar warranty and service plans will help you maximize your investment by providing great support, display uptime, and performance optimization. From post-sale technical support to a full suite of depot services, our services are performed by trained Planar employees. When you purchase a Planar product, you get more than a display, you get the service and support you need to maximize your investment. To find the latest warranty and service information regarding your Planar product, please visit <http://www.planar.com/support/>

RoHS Compliance Statement

The Clarity Matrix Video Walls are fully RoHS compliant.

ADA Compliance Statement

Some Clarity Matrix G2 models are compliant with the Americans with Disabilities Act Section 4

Manual Part Number: 020-1248-00C

Contents

| | |
|---|----|
| Introduction | 1 |
| Safety Information | 2 |
| Important Safety Instructions | 2 |
| Recommended Usage | 5 |
| Burn-In Versus Temporary Image Retention | 5 |
| Normal Use Thermal Guidelines | 6 |
| Safe Handling | 6 |
| Improper handling of the displays can cause problems like these: | 7 |
| How NOT To Handle LCDs | 8 |
| How to SAFELY Handle the LCDs | 9 |
| How to Remove the Liner—Non-ERO Units | 10 |
| How to Remove the Liner—ERO Units | 11 |
| System Architecture | 12 |
| EasyAxis Mounts, General Description | 14 |
| Matrix Video Wall | 14 |
| LCD Modules | 15 |
| LCD Mounting Structure | 16 |
| Off-Board Equipment and Components | 18 |
| Quad Controller Module | 18 |
| Power Supply Module | 19 |
| Identifying your Power Supply Module Type | 20 |
| Planning for your Power Supply Configuration | 20 |
| Installing a Clarity™ Matrix LCD Video Wall System with G2 Architecture | 21 |
| Before You Begin | 21 |
| Tools/Equipment List | 21 |
| Other Things You May Need | 21 |
| Safe Handling of the LCD Modules | 21 |
| Plan Your Installation | 22 |
| Calculating DC Power Requirements and Component Heat Load | 23 |
| Installation Checklist | 27 |

| | |
|---|-----------|
| Unpacking and Checking Accessories | 27 |
| Cabling and Installation of Power Supply Modules | 27 |
| Electronics Box | 29 |
| LCD Module Box | 30 |
| Accessory Box(es) | 31 |
| Accessory Kit | 32 |
| Optional Planar-Supplied Accessories | 34 |
| Wall Installation | 35 |
| Wall Installation Options | 35 |
| Installing the LCD Mount Structure | 36 |
| Mounting Brackets to a Wall | 37 |
| Installing Brackets on the First Row of a Fixed Wall | 39 |
| Installing Brackets on Subsequent Rows | 41 |
| Routing Cables | 42 |
| Placing Off-Board Module Equipment | 44 |
| Plugging In Cables to the Off-Board Modules | 44 |
| Installation Considerations; Tips for Adjusting Walls | 46 |
| Installing the First or Bottom Row | 48 |
| Installing Second and Subsequent Rows | 56 |
| Mounting the IR Sensor | 57 |
| Connecting the IR Sensor | 57 |
| Mounting the Ambient Light Sensor | 58 |
| RS485 Quad Module Connections | 58 |
| Checking Your Connections | 59 |
| System Addresses | 60 |
| Setting the Address of Each Quad Controller Module | 61 |
| Connecting Sources | 61 |
| Quad Controller Status LEDs | 62 |
| Loop-Through | 63 |
| Configuring a Clarity Matrix Video Wall | 64 |
| Menu Settings | 64 |
| Basic Configuration Steps | 64 |

| | |
|--|----|
| Master vs. Slave Displays | 64 |
| Menus and the Remote | 65 |
| Navigational Menus | 66 |
| Global Menu | 66 |
| Status Menu | 66 |
| Local Menu | 67 |
| Display IDs | 68 |
| RS232 Communication | 69 |
| Connecting RS232 Cables | 69 |
| Matrix Layout Menu | 70 |
| Adjusting Color Balance | 71 |
| Understanding Color Temperature | 71 |
| Adjusting Color Temperature | 71 |
| Color Balancing Multiple Displays | 72 |
| Tips for Color Balancing | 75 |
| Advanced Options | 77 |
| Miscellaneous Options | 78 |
| Auto Color Space | 79 |
| Color Depth | 79 |
| Setting the Clock and Scheduling an Event | 81 |
| Setting the Clock | 83 |
| Scheduling an Event | 83 |
| Aspect Ratio Settings | 86 |
| Scale Mode Settings | 86 |
| Justify Settings | 89 |
| Overscan | 89 |
| Sharpness | 89 |
| Backlight Control | 90 |
| Auto Backlight On | 91 |
| Turn Backlight Off With No Source and (DPMS) Delay | 91 |
| Backlight Intensity | 91 |
| Dimmed Intensity (Backlight Control Mode is AUTO only) | 91 |
| Ambient Threshold | 91 |
| Controlling EDID Behavior | 93 |
| Orbiter Control | 95 |
| Spreading Images Across the Wall | 96 |
| Using an External Video Processor | 96 |
| Using the Quick Configure Feature | 96 |

| | |
|--|------------|
| Using the Matrix Layout..... | 96 |
| Using Planar's Big Picture™..... | 97 |
| Zoom and Viewport..... | 101 |
| Zoom Menu Entries..... | 101 |
| Viewport Adjustment..... | 102 |
| Adjusting Position..... | 104 |
| Serial Port Settings and Diagnostics..... | 105 |
| Serial Port Settings..... | 105 |
| Serial Port Status..... | 106 |
| Controlling With RS232 Commands..... | 106 |
| Diagnostics..... | 107 |
| Checking Unit Status..... | 107 |
| Checking System Usage..... | 108 |
| Communicating via Network..... | 110 |
| Saving and Recalling Configurations..... | 111 |
| Advantages of Saving Configurations to Memory Slots..... | 111 |
| What the Memories Store..... | 111 |
| Global Storage..... | 111 |
| Memory: What Is Saved? And Where?..... | 112 |
| Saving Configurations..... | 113 |
| Changing the Name of the Memory Slot..... | 114 |
| Recalling Stored Configurations..... | 115 |
| Deleting a Configuration..... | 117 |
| Understanding Wall Configuration..... | 119 |
| Configuration Scenarios..... | 120 |
| Standard Cabling Scenarios..... | 120 |
| Standard Cabling with Restrictions on LCD Placement..... | 128 |
| DisplayPort Input Scenarios..... | 133 |
| Complex Configurations..... | 136 |
| Understanding the Quad Module Route Menu..... | 138 |
| Configuring High Resolution Inputs..... | 140 |
| Hardware Limitation..... | 140 |
| High Resolution Setup..... | 140 |
| Dual Link vs. Single Link..... | 141 |
| Cabling for High Resolution..... | 142 |

| | |
|---|------------|
| Configuring a New High Resolution Input | 142 |
| Handling Vertical Resolutions Greater Than 2047 Pixels | 143 |
| Supported Resolution Summary | 143 |
| Commonly Used Big Picture resolutions | 144 |
| On-Screen Menus..... | 145 |
| Troubleshooting..... | 157 |
| Common Symptoms and How to Troubleshoot Them | 161 |
| Symptom: Black Screen | 161 |
| Symptom: Picture Is Not Displaying Correctly..... | 164 |
| Servicing..... | 165 |
| Specifications..... | 166 |
| LCD Module Specifications for MX46HDS, MX55HDS, MX46HDU, LX55HDU, MX55HDU | 166 |
| LCD Module Specifications for LX46HDS, LX55HDS | 167 |
| LCD Module Specifications for LX46S-3D | 168 |
| Quad Controller Module Specifications | 169 |
| Power Supply Module Specifications | 169 |
| LCD Optical Specifications | 170 |
| Environmental Specifications | 172 |
| Signal Compatibility | 173 |
| Input Minimum Sync and Blanking Specifications | 177 |
| Cleaning the ERO Matrix Wall | 178 |
| Required Materials | 178 |
| Silicone Removal | 178 |
| Cleaning the Glass..... | 179 |
| Matrix Drawings | 180 |
| MX46HDS Dimensions – Landscape..... | 181 |
| MX46HDS Front, Top, and Bottom Views – Landscape | 181 |
| MX46HDS Rear View – Landscape | 182 |
| MX46HDS Side View – Landscape | 183 |
| MX46HDS Dimensions – Portrait | 184 |
| MX46HDS Top and Bottom Views – Portrait..... | 184 |

| | |
|--|-----|
| MX46HDS Front View – Portrait | 185 |
| MX46HDS Rear View – Portrait | 186 |
| MX46HDS Side View – Portrait | 187 |
| MX55HDS Dimensions – Landscape..... | 188 |
| MX55HDS Top, Front, and Bottom Views – Landscape | 188 |
| MX55HDS Rear View – Landscape | 189 |
| MX55HDS Side View – Landscape | 190 |
| MX55HDS Dimensions – Portrait | 191 |
| MX55HDS Top and Bottom – Portrait..... | 191 |
| MX55HDS Front View – Portrait | 192 |
| MX55HDS Rear View – Portrait | 193 |
| MX55HDS Side Views – Portrait | 194 |
| LX46HDS Dimensions – Landscape..... | 195 |
| LX46HDS Front, Top, and Bottom Views – Landscape | 195 |
| LX46HDS Rear View – Landscape..... | 196 |
| LX46HDS Side Views – Landscape..... | 197 |
| LX46HDS Dimensions – Portrait..... | 198 |
| LX46HDS Front and Side Views – Portrait..... | 198 |
| LX46HDS Rear View – Portrait | 199 |
| LX46HDS Side View – Portrait | 200 |
| LX55HDS Dimensions – Landscape..... | 201 |
| LX55HDS Front, Top, and Bottom Views – Landscape | 201 |
| LX55HDS Rear View – Landscape..... | 202 |
| LX55HDS Side View – Landscape | 203 |
| LX55HDS Dimensions – Portrait..... | 204 |
| LX55HDS Front View – Portrait | 204 |
| LX55HDS Rear View – Portrait | 205 |
| LX55HDS Side View – Portrait | 206 |
| LX46S-3D Dimensions Landscape (only)..... | 207 |
| LX46S-3D Front, Top, and Bottom Views..... | 207 |
| LX46S-3D Rear View | 208 |
| LX46S-3D Side Views | 209 |
| MX46HDU Dimensions – Landscape | 210 |
| MX46HDU Top, Front, and Bottom Views – Landscape | 210 |
| MX46HDU Rear View – Landscape..... | 211 |
| MX46HDU Side Views – Landscape..... | 212 |
| MX46HDU Dimensions – Portrait..... | 213 |
| MX46HDU Top and Bottom Views – Portrait | 213 |

| | |
|---|------------|
| MX46HDU Front View – Portrait | 214 |
| MX46HDU Rear View – Portrait | 215 |
| MX46HDU Side Views – Portrait | 216 |
| LX/MX55HDU Dimensions – Landscape | 217 |
| LX/MX55HDU Top, Front, and Bottom Views – Landscape | 217 |
| LX/MX55HDU Rear View – Landscape | 218 |
| LX/MX55HDU Side Views – Landscape | 219 |
| LX/MX55HDU Dimensions – Portrait | 220 |
| LX/MX55HDU Top and Bottom Views – Portrait | 220 |
| LX/MX55HDU Front View – Portrait | 221 |
| LX/MX55HDU Side Views – Portrait | 222 |
| LX/MX55HDU Rear View – Portrait | 223 |
| Drawings of Display Mounts | 224 |
| LX/MX55HDU and LX55HDS – Landscape | 225 |
| LX/MX55HDU and LX55HDS – Portrait | 226 |
| MX46HDU, MX46HDS, and LX46HDS – Landscape | 227 |
| MX46HDU, MX46HDS, and LX46HDS – Portrait | 228 |
| MX55HDS – Landscape | 229 |
| MX55HDS – Portrait | 230 |
| LX46S-3D – Landscape (only) | 231 |
| Dimensions of Electronic Components | 232 |
| Power Supply Module | 232 |
| Quad Controller Module | 233 |
| Main DC Power Cable | 234 |
| Power Supply to Quad Power Cable | 234 |
| Installing Optional Accessories | 235 |
| Planar’s Technical Support Website | 237 |
| Downloading Additional Documentation and Firmware | 237 |
| Downloading Utility Software | 237 |
| Regulatory Information | 238 |
| Index | 239 |

Introduction

The Clarity™ Matrix LCD Video Wall System with G2 Architecture uses cutting edge technology to provide a video wall solution using commercial-grade 46" and 55" full high definition (FHD) LCDs in a tiled application. The Clarity Matrix G2 utilizes cutting edge ultra-narrow bezel LCD with a combined bezel width as small as 3.7mm. The product can support up to full HD format with a 1920 x 1080 resolution per panel. All products have an aspect ratio of 1.77 (16:9). The Clarity Matrix G2 can be installed with the minimum install depth of 3.6". The system accepts a wide range of input digital signals.

The EasyAxis™ mounting system supports landscape and portrait orientation, free-standing wall deployment and flying wall applications. Because the panels are self-supporting, Clarity Matrix can support unlimited stacking height.



Caution: This manual is intended for use by qualified service persons and end users with experience installing LCD displays.

Safety Information

This display was designed with safety in mind. If you don't heed the safety warnings and cautions, you could be injured. There are safety warnings on stickers in various places in and on the display.



Important Safety Instructions

- 1 Read these instructions.
- 2 Keep these instructions.
- 3 Heed all warnings.
- 4 Follow all instructions.
- 5 Do not use any of the Clarity™ Matrix LCD Video Wall System with G2 Architecture products near water.
- 6 Clean the LCD screens with an LCD screen cleaner or LCD wipes.
- 7 Do not install near any heat sources such as radiators, heat registers, stoves or other apparatus (including amplifiers) that produce heat.
- 8 Do not defeat the safety purpose of the polarized or grounding type plug. A polarized plug has two blades with one wider than the other. A grounding type plug has two blades and a third grounding prong. The wide blade or the third prong is provided for your safety. When the provided plug does not fit into your outlet, consult an electrician for the replacement of the obsolete outlet.
- 9 Protect the power cord from being walked on or pinched particularly at plugs, convenience receptacles and the point where they exit from any of the Clarity™ Matrix LCD Video Wall System with G2 Architecture products.
- 10 Only use the attachments/accessories specified by the manufacturer.
- 11 Unplug all Clarity™ Matrix LCD Video Wall System with G2 Architecture products during lightning storms or when unused for long periods of time.
- 12 You must follow all National Electrical Code regulations. In addition, be aware of local codes and ordinances when installing your system.

- 13** Refer all servicing to qualified service personnel. Servicing is required when any of the Clarity™ Matrix LCD Video Wall System with G2 Architecture products have been damaged in any way, such as the AC power cord or plug is damaged, liquid has been spilled or objects have fallen into a product, the products have been exposed to rain or moisture, do not operate normally or have been dropped.
- 14** Keep the packing material in case the equipment should ever need to be shipped.
- 15** Wall mounts must be secure. The wall must be strong enough to hold all LCD modules, brackets and cables. (See "LCD Module Specifications for MX46HDS, MX55HDS, MX46HDU, LX55HDU, MX55HDU" on page 166.)
- 16** Slight pressure on the LCD will cause distortion of the image. Heavier pressure will cause permanent damage. Clarity Matrix Video Walls should be mounted where viewers cannot touch the screen or insert small objects in the openings that will create hazards by contacting bare conductive parts.

Caution: The front polarizer is soft and subject to scratches from sharp objects.

- 17** The polarizer is a thin sheet of film laminated to the outside layer of glass on the LCD screen. Take care when handling items near the screen.

Caution: This product contains a lithium battery. There is a risk of explosion if the battery is replaced by an incorrect type. Dispose of the battery according to the instructions on the next page.

- 18** The panels are meant to be installed electrically isolated from ground. Grounding to the building may cause issues with performance.

English

- Disposal of old Electrical & Electronic Equipment (Applicable throughout the European Union and other European countries with separate collection programs)

This symbol found on your product or on its packaging, indicates that this product should not be treated as household waste when you wish to dispose of it. Instead, it should be handed over to an applicable collection point for the recycling of electrical and electronic equipment. By ensuring this product is disposed of correctly, you will help prevent potential negative consequences to the environment and human health, which could otherwise be caused by inappropriate disposal of this product. The recycling of materials will help to conserve natural resources.



This symbol is only valid in the European Union. If you wish to discard this product, please contact your local authorities or dealer and ask for the correct method of disposal.

Español

- Deshecho de equipos eléctricos y electrónicos (aplicable a la Unión Europea y a otros países europeos con programas de reciclaje independientes)

La presencia de este símbolo en el propio producto o en su material de embalaje, indica que no se debe tratar como residuo doméstico cuando desee deshacerse de él. En su lugar, debe entregarlo en el punto limpio correspondiente de reciclaje de equipos eléctricos y electrónicos. Asegurándose de que este producto se desecha de forma correcta, ayudará a evitar posibles consecuencias negativas para la conservación del medioambiente y la salud humana, consecuencias que podrían darse si se desecha del producto de forma inadecuada. El reciclado de materiales ayuda a conservar los recursos naturales.



Este símbolo solamente es válido en la Unión Europea. Si desea deshacerse de este producto, póngase en contacto con las autoridades locales o con su distribuidor y pida información sobre el método de disposición adecuado.

Português

- Eliminação de equipamentos eléctricos e electrónicos usados (aplicável na União Europeia e noutros países europeus com programas próprios de recolha destes equipamentos)

Este símbolo, colocado no produto ou na respectiva embalagem, indica que o produto não deve ser tratado como lixo doméstico aquando da sua eliminação. Em vez disso, deve ser entregue num ponto de recolha de equipamentos eléctricos e electrónicos para posterior reciclagem. Ao garantir a correcta eliminação deste produto, estará a evitar consequências potencialmente negativas tanto para o ambiente como para a saúde humana. A reciclagem de materiais ajuda a preservar os recursos naturais.



Este símbolo apenas é válido na União Europeia. Se quiser eliminar este produto, contacte as entidades locais ou o seu fornecedor para ficar a saber qual o método de eliminação correcto.

Svenska

- Avfall av förbrukad elektrisk och elektronisk utrustning (Tillämpbart i hela Europeiska unionen och andra europeiska länder med separata samlingsprogram)

Den här symbolen som finns på din produkt eller på dess förpackning påvisar att produkten inte ska behandlas som hushållsavfall när du vill slänga bort den. Istället ska den lämnas över till en lämplig uppsamlingspunkt för återvinning av elektriska och elektroniska utrustningar. Genom att tillförsäkra att den här produkten återvinns på ett riktigt sätt hjälper du till med att förhindra möjliga negativa konsekvenser för miljön och mänsklig hälsa. Det kan annars orsakas på grund av olämplig sophantering av den här produkten. Återvinning av material kommer att hjälpa till att bevara naturtillgångar.



Den här symbolen är endast giltig inom den Europeiska unionen. Om du vill slänga bort den här produkten ska du kontakta lokala myndigheter eller återförsäljare, och fråga efter lämplig avfallsmetod.

Français

- Mise au rebut des équipements électriques et électroniques usagés (Valable dans l'ensemble de l'Union Européenne ainsi que dans les pays européens disposant de programmes distincts de collecte des déchets)

Ce symbole appliqué sur votre produit ou sur son emballage indique que ce produit ne doit pas être traité comme un déchet ménager lorsque vous voulez le mettre au rebut. Il doit au contraire être remis à un site de collecte agréé pour le recyclage des équipements électriques et électroniques. En veillant à ce que ce produit soit mis au rebut de façon adéquate, vous contribuerez à prévenir les conséquences potentiellement négatives sur l'environnement et sur la santé humaine qui risqueraient de se produire en cas de mise au rebut inappropriée de ce produit. Le recyclage des matériaux contribuera également à économiser les ressources naturelles.



Ce symbole n'est valable que dans l'Union Européenne. Si vous souhaitez mettre ce produit au rebut, veuillez prendre contact avec les autorités locales ou avec votre revendeur et renseignez-vous sur la méthode de mise au rebut correcte.

Italiano

- Smaltimento delle attrezzature elettriche ed elettroniche usate (applicabile in tutta la Comunità Europea ed altri Paesi Europei che applicano programmi di raccolta differenziale)

Il simbolo trovato sul prodotto, o sulla sua confezione, indica che il prodotto non può essere trattato come i domestici quando è il momento di smaltirlo. Al contrario, deve essere consegnato ad un centro di raccolta specializzato nel riciclaggio di attrezzature elettriche ed elettroniche. Assicurando che il corretto smaltimento di questo prodotto, si aiuterà a prevenire potenziali conseguenze negative sull'ambiente e sulla salute umana, che possono essere provocate da uno scorretto smaltimento di questa attrezzatura. I materiali riciclati aiuteranno a conservare le risorse naturali.



Questo simbolo è valido solo nell'Unione Europea. Per smaltire questo prodotto, mettersi in contatto con le autorità locali - o con il rivenditore - e chiedere informazioni sul corretto metodo di smaltimento.

Polski

- Użycie zużytego sprzętu elektrycznego i elektronicznego (Dotyczy krajów Unii Europejskiej i innych krajów europejskich z oddzielnymi programami zbiórki odpadów)

Obecność tego symbolu na produkcie lub na opakowaniu z produktem oznacza, że tego produktu nie można wyrzucać razem z odpadami domowymi. Należy go przekażać do punktu zbiórki w celu poddania recyklingowi podzespołów elektrycznych i elektronicznych. Usunięcie tego produktu w prawidłowy sposób, pomoże w zabezpieczeniu przed negatywnym wpływem odpadów na środowisko i zdrowie ludzi, powodowanym przez niewłaściwe usunięcie produktu. Przetwarzanie materiałów pomaga w zachowaniu zasobów naturalnych.



Ten symbol obowiązuje wyłącznie w krajach Unii Europejskiej. Informacje dotyczące prawidłowej metody usunięcia tego produktu, można uzyskać u władz lokalnych lub u dostawcy.

Suomi

- Vanhojen sähkö- ja elektroniikkalaitteiden hävittäminen (Soveltuva kaikkialla Euroopan unionin alueella, sekä muissa Euroopan maissa, joilla on erilliset keräysohjelmat)

Jos tuotteessa tai sen pakkauksessa on tämä symboli, sitä ei pidä hävittää tavallisella tavalla kotitalousjätteenä, vaan se kuuluu toimittava sähkö- ja elektroniikkalaitteiden kierrätysjärjestelmään. Varmistamalla, että tämä tuote hävitetään asianmukaisella tavalla autat estämään mahdollisia ympäristölle ja ihmisille koltuvia negatiivisia seurauksia, joita sen vääräntäinen hävittäminen voi aiheuttaa. Materiaalien kierrättäminen auttaa säilyttämään luonnonvarjoja.



Tämä symboli on voimassa ainoastaan Euroopan unionin alueella. Jos haluat hävittää tämän tuotteen, ota yhteyttä paikallisiin viranomaisiin tai jälleenmyyjään ja tiedustele asiaankuuluvia hävittämistapoja.

Deutsch

- Entsorgung von elektrischen & elektronischen Altgeräten (geltend für die europäische Gemeinschaft und andere europäische Länder mit separaten Sammelprogrammen)

Dieses Symbol, zu finden auf Ihrem Produkt oder dessen Verpackung, macht Sie darauf aufmerksam, dass dieses Produkt bei der Entsorgung nicht als Hausmüll behandelt werden darf. Statt dessen sollte es an eine Sammelstelle zum Recycling von elektrischen und elektronischen Altgeräten gegeben werden. Helfen Sie mit, potenziell schädliche Einflüsse auf Umwelt und Gesundheit, die durch eine unsachgemäße Entsorgung dieses Produktes entstehen können, zu vermeiden und entsorgen Sie dieses Produkt ordnungsgemäß. Recycling hilft, natürliche Rohstoffe einzusparen.



Dieses Symbol ist nur innerhalb der europäischen Gemeinschaft gültig. Wenn Sie dieses Produkt entsorgen möchten, wenden Sie sich bitte an Ihre örtliche Behörde und fragen Sie nach der ordnungsgemäßen Entsorgungsmethode.

Nederlands

- Verwijderen van oude elektrische en elektronische apparatuur (toepasselijk in de volledige Europese Unie en andere Europese landen met afzonderlijke programma's voor afvalverzameling)

Dit symbool dat op het product of zijn verpakking is aangebracht, geeft aan dat dit product niet mag worden behandeld als huishoudelijk afval als u het wilt wegwerpen. U moet het afgeven bij een specifiek verzamelpunt voor de recyclage van elektrische en elektronische apparatuur. Door te garanderen dat u dit product op de correcte manier wegwerpt, helpt u potentiële negatieve gevolgen voor het milieu en de menselijke gezondheid, die zouden kunnen worden veroorzaakt door een onrechtmatig wegwerpen van het product, te voorkomen. De recyclage van materialen helpt het behoud van natuurlijke bronnen.



Dit symbool is alleen geldig in de Europese Unie. Als u dit product wenst weg te gooien, dient u contact op te nemen met uw lokale instanties voor details over de gepaste methode voor afvalverwijdering.

Waste Electrical and Electronic Equipment (WEEE) Directive in the European Union, this label indicates that this product should not be disposed of with household waste. It should be deposited at an appropriate facility to enable recovery and recycling. EEE complies with Directive 'Regulation on the Restriction of the Use of Certain Hazardous Substances in Electrical and Electronic Equipment'



Waste Electrical and Electronic Equipment (WEEE) Yönergeleri Avrupa Birliği'nde bu etiket, ürünün ev elektroniği aletleri atıklar ile imha edilemeyeceğini gösterir. Kurtarmak ve geri dönüşümünü sağlamak için uygun şartlarda saklanması gerekir. EEE Yönetmeliğine Uygunluk Ve Elektriklik Eşyalarda Bazı Zararlı Maddelerin Kullanımını Sınırladığına Dair Yönetmelik.



Recommended Usage

In order to get the most out of your LCD modules, use the following recommended guidelines to optimize the display.

Burn-In Versus Temporary Image Retention

Burn-in causes the screen to retain an image essentially forever, with little or no way to correct the problem. Under normal use, an LCD module will not experience burn-in, as plasma displays do, nor will it retain images in any way.

Normal use of an LCD module is defined as displaying continuously changing video patterns or images. However, LCD modules can experience *temporary* image retention when recommended usage guidelines are not followed.

What is Temporary Image Retention?

Temporary image retention (TIR) can occur when a static image is displayed continuously for extended periods of time. An electrical charge differential may build up between the electrodes of the liquid crystal, which causes a negative-color video image (color-inverted and brightness-inverted version of the previous image) to be retained when a new image is displayed. This behavior is true for any LCD device from any LCD manufacturer.

TIR is not covered under warranty. See standard warranty terms and conditions for details. Here are some guidelines to help you avoid TIR:

- Use the LCD module to show a screen saver, moving images or still pictures that change regularly. When using high-contrast images, reposition the images frequently.
- Turn off the LCD module when it is not in use. There are a few ways to do this automatically:
 - To use the LCD module's real-time clock, see "Setting the Address of Each Quad Controller Module" on page 61.
 - To use your source computer's Power Options Properties, set up your computer to turn off the display when not in use. You also need to check the DPMS checkbox and set the DPMS DELAY box in the BACKLIGHT SETTINGS menu (MAIN MENU > ADVANCED OPTIONS > BACKLIGHT SETTINGS).
 - To use RS232 commands, see "RS232 Communication" on page 69.
 - Use a remote switch connected to the power supply.

Caution: For optimal performance, we suggest turning off the power to the Clarity Matrix panels for four hours per day.

Normal Use Thermal Guidelines

Normal use of the LCD module, Quad controller module and power supply module are defined as **operating in the open air** to prevent heat buildup, and without direct or indirect heat sources such as lighting fixtures, heating ducts, or direct sunlight that can cause the modules to experience high operating temperatures. For all modules, do not block fans or ventilation openings. If the LCD module will be installed in a recessed area with an LCD surround or enclosed system, ensure adequate openings are applied for proper air flow and ventilation.

At 2000 meters or below, the maximum ambient operating temperature for the **LCD module** cannot be above 35° C nor below the minimum ambient operating temperature of 5° C (as measured at the surface of the screen). For the Quad controller module and power supply module, the maximum ambient operating temperature cannot be above 40° C nor below the minimum ambient operating temperature of 10° C. If one of these conditions is exceeded, it is up to the installer to ensure that module placement is changed, thermal shielding is provided, and/or additional ventilation is provided to keep the system within its nominal operating parameters. (See "Environmental Specifications" on page 172)

Cooling Requirements

For optimal performance, active cooling by the installer should be planned for when the ambient temperature of the wall is predicted to be above the specified ambient temperature for the panel. Cooling may be done behind the displays and depending on the wall configuration, it may be helpful to place air ducts (AC) at every third display tall.

Safe Handling

WARNING There are special ways to handle the Matrix displays. *Safe handling*, in this instance, means **not damaging the displays**. See below.

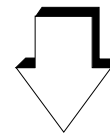

Improper handling of the displays can cause problems like these:



Line/Column defect

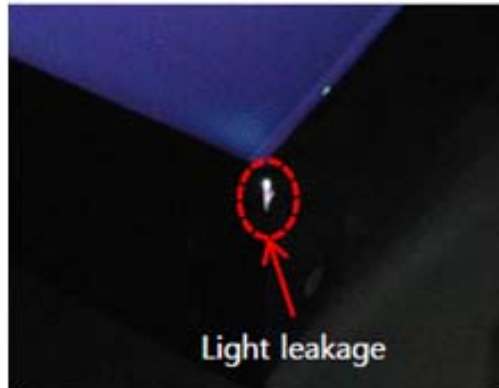

Light leakage caused by damaged corner tape



Light leakage caused by bent chassis



Million peeling away from bezel (ERO units only)

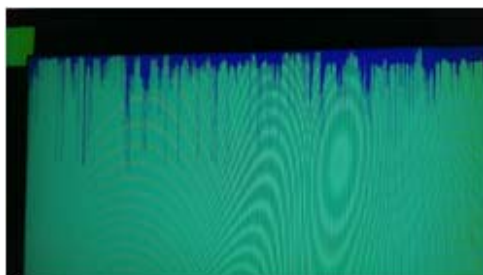

Screen bleeding caused by chipped LCD



Silicone pulling out of seams (ERO units only)

How **NOT** To Handle LCDs



Caution: Do NOT lift the display by its bag. The bag tears easily, and it might drop.



Caution: If the display must be temporarily stored out of the original packaging, do not let it stand at an angle of more than 10°.



Caution: Do not apply force to the LCD.

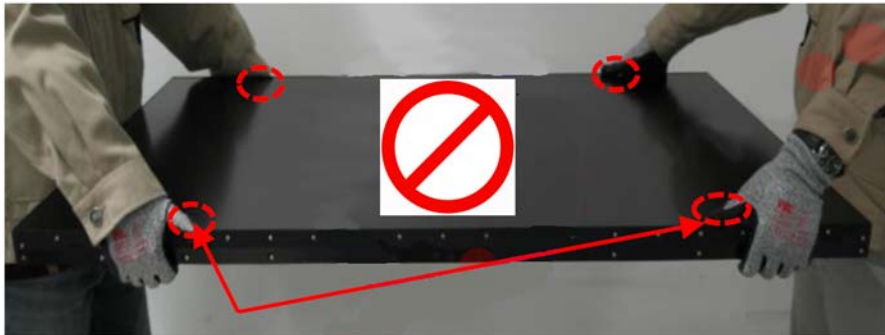

Caution: Do not carry flat. Do not put pressure on the active bezel.

Note: Models LX55HDU and MX55HDU are more fragile than the other models and should be handled very carefully.

Caution: Follow these guidelines. Failure to do so can result in damage to the LCD.

- ALWAYS carry the LCD vertically by the handles (see below).
- Do NOT grip the LCD around the bezel edges.
- ALWAYS have **2** people to carry the displays. NEVER carry it alone.

How to **SAFELY** Handle the LCDs



Landscape shown

The displays should always be vertical.

Lift the units with **two (2)** people using the handles shown here. Handling the unit in any other way could cause damage to the LCD or the top chassis.



Portrait shown

How to Remove the Liner—Non-ERO Units

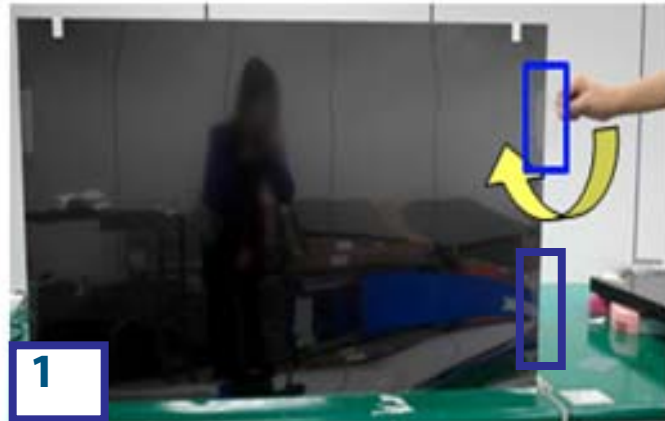

- 1 Gently peel back the clear tape from the *right* side bezel edge.

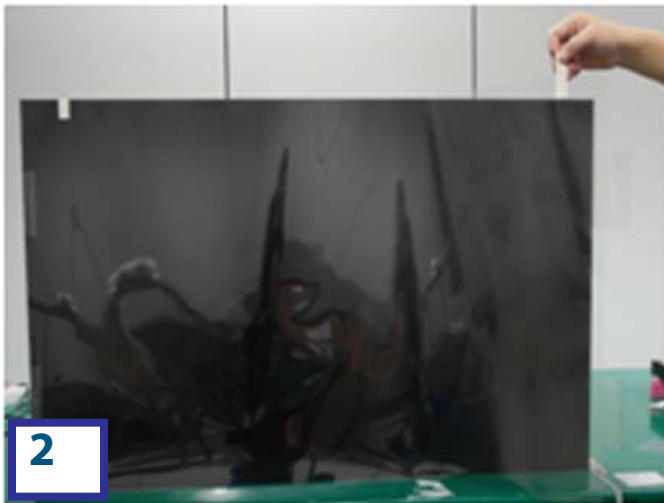

- 2 Peel back the masking tape from the *top* edge of the unit.



- 3 Gently peel back the clear tape from the other bezel edge and remove the Mylar liner.

How to Remove the Liner—ERO Units



While wearing nitrile/latex gloves (which are included in the accessories kit) slowly peel the liner back over itself and off the display.

Note: A static charge is released when the liner is removed. Slow liner release reduces this charge and reduces the risk of damage to the electronics.

System Architecture

The Clarity Matrix Video Wall has three main electronic components: the LCD module, power supply module and the Quad controller module. The LCD module has a removable interface board, which connects to the off-board power supply and Quad controller modules. Using external modules produces less heat and allows for reduced and/or easier service of the LCD module itself.

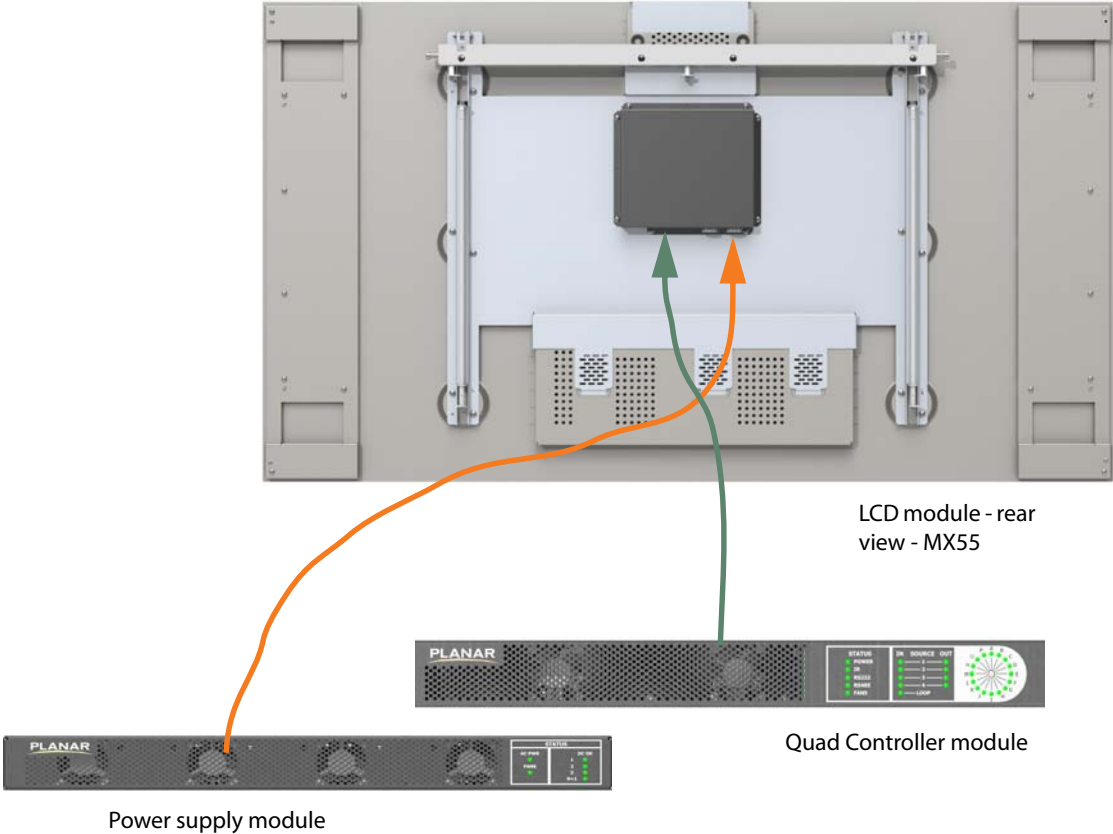

Some basic points to keep in mind:

- Each Quad controller module controls up to four LCDs
- Modules are linked together by RS485 cables
- The first processor in the A Quad controller module (A1) is the master processor
- The master processor takes in the input from the IR remote sensor and/or the host RS232 commands
- The total number of power supply modules is dependent on the different model and cable length between the rack mount components and the LCD modules.

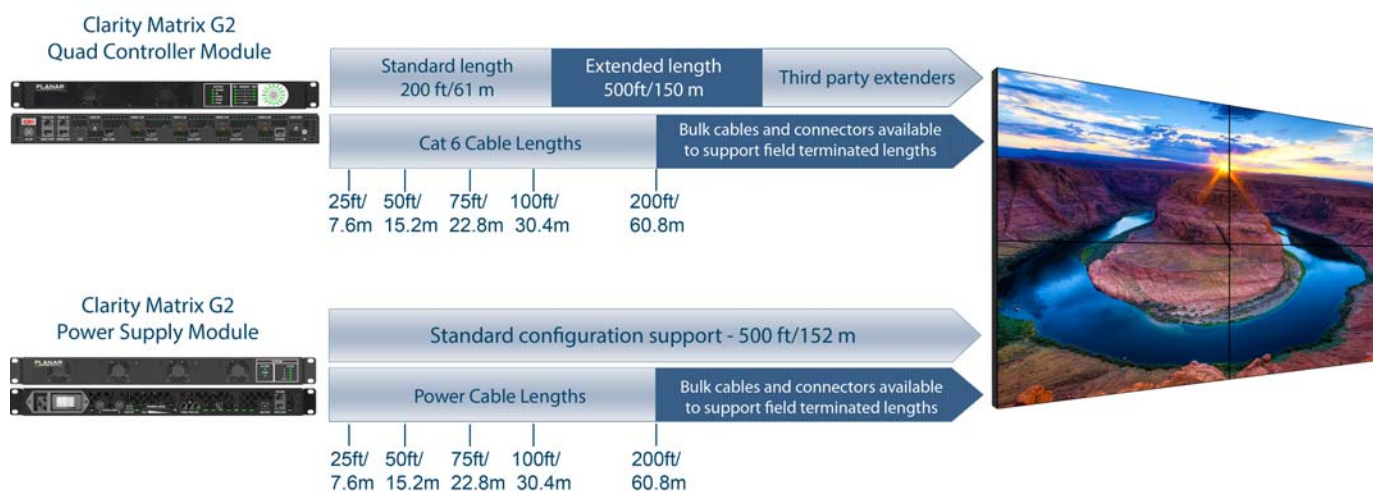

The following example shows the connections for a basic video wall.

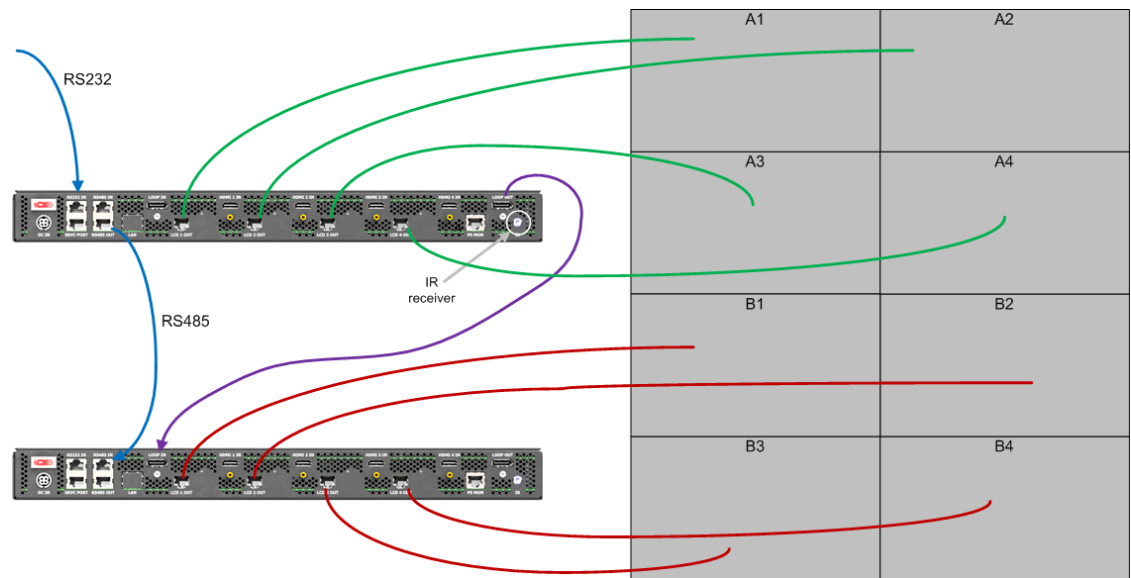

EasyAxis Mounts, General Description

EasyAxis™ mounts are included with most models and are used to secure the Clarity Matrix Video Wall for display. Follow these instructions carefully.

Keep in mind the following general installation guidelines:

- Prior to installation, make sure you know where all of the mounting points are located.
- Follow all safety precautions outlined in this manual.
- Verify the parts received with the list shown in this manual.

Matrix Video Wall

The Matrix G2 can be ordered as either landscape or portrait. For customers wanting to use a third-party VESA mount, most Clarity Matrix models can be ordered without the EasyAxis mount and includes a VESA standard hole pattern.

The Clarity™ Matrix LCD Video Wall System with G2 Architecture consists of several different modules. These are described in more detail on the following pages.

LCD Modules

The LCD module is composed of a basic LCD without a cosmetic enclosure but with a mechanical subframe for mounting. It incorporates a simple interface board designed to distribute off-board power, video and control signals to the LCD module, keeping depth, weight, heat and points of potential failure to a minimum. Most LCD modules are available with ERO™ protective glass for added protection in public spaces or for use as a touch surface. The LCD blade-style module incorporates a bracket that is perfectly paired with the EasyAxis mount. The LCD module includes EasyAxis adjustment cams that facilitate precise six-axis alignment ensuring uniform, minimized image-to-image gap.

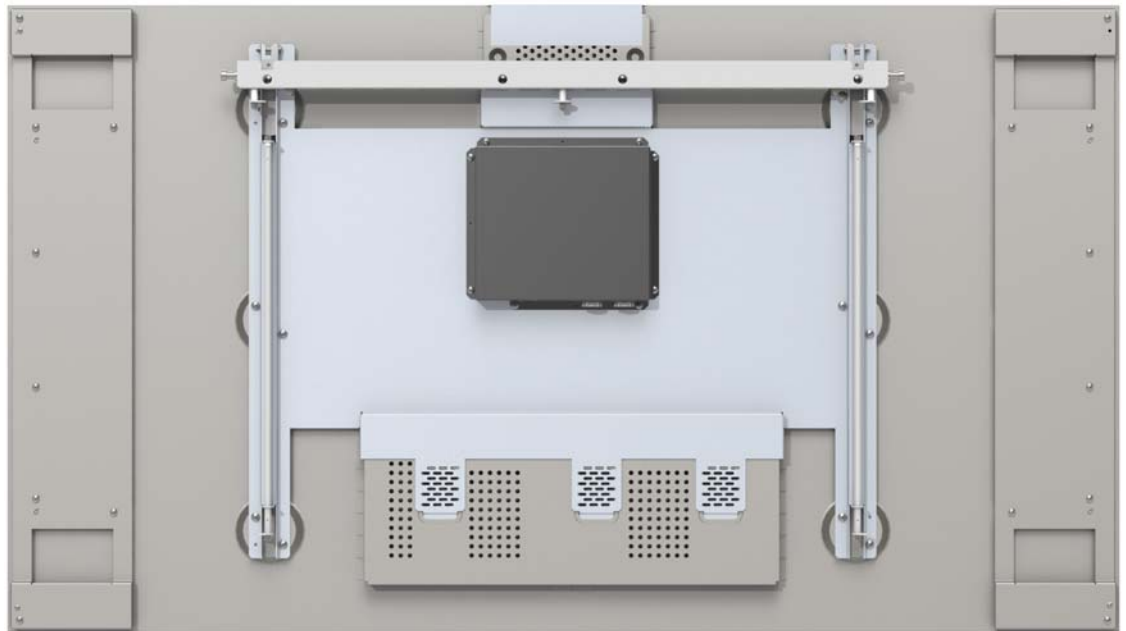

Note: This shows a rear picture of the MX55.

LCD Mounting Structure

The EasyAxis mounting system simplifies the task of installing and aligning the LCD modules while allowing for efficient in-wall service. EasyAxis is designed to be attached to a wall, used with optional free-standing bases, or secured overhead. When assembled, horizontal and vertical connection brackets ensure that each mount is perfectly spaced from its neighbor in the video wall. The mount system also incorporates a service mode to accommodate front and rear in-wall repair of any LCD module in the video wall.

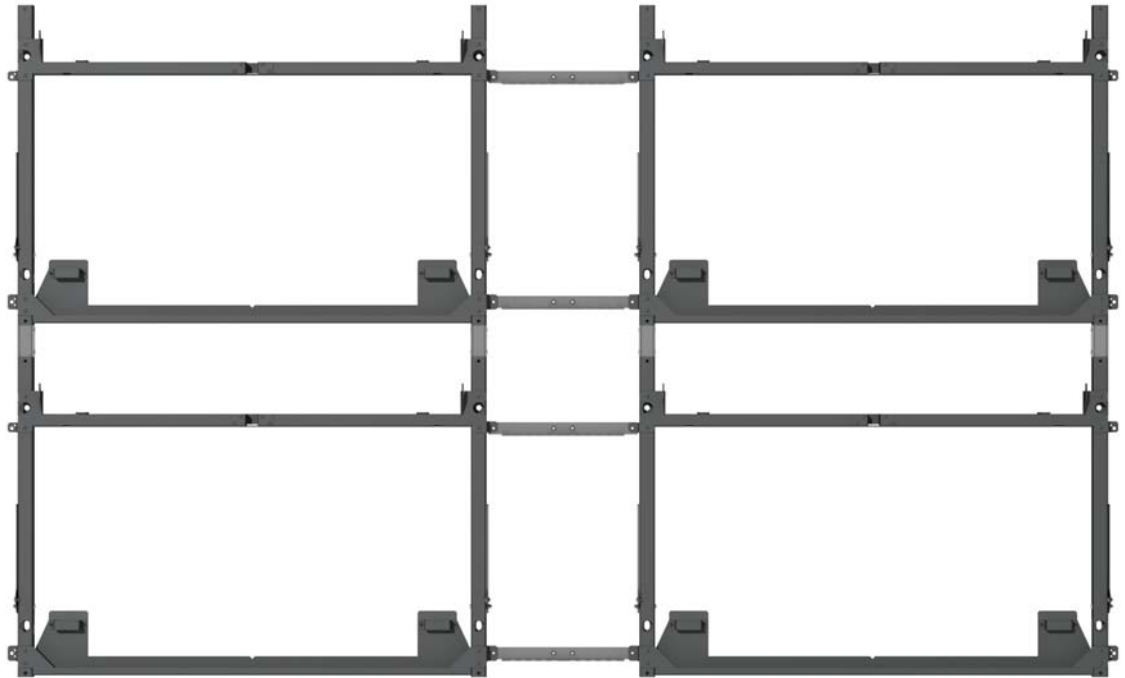

Note: This image is an example of a landscape mount 2x2 configuration.

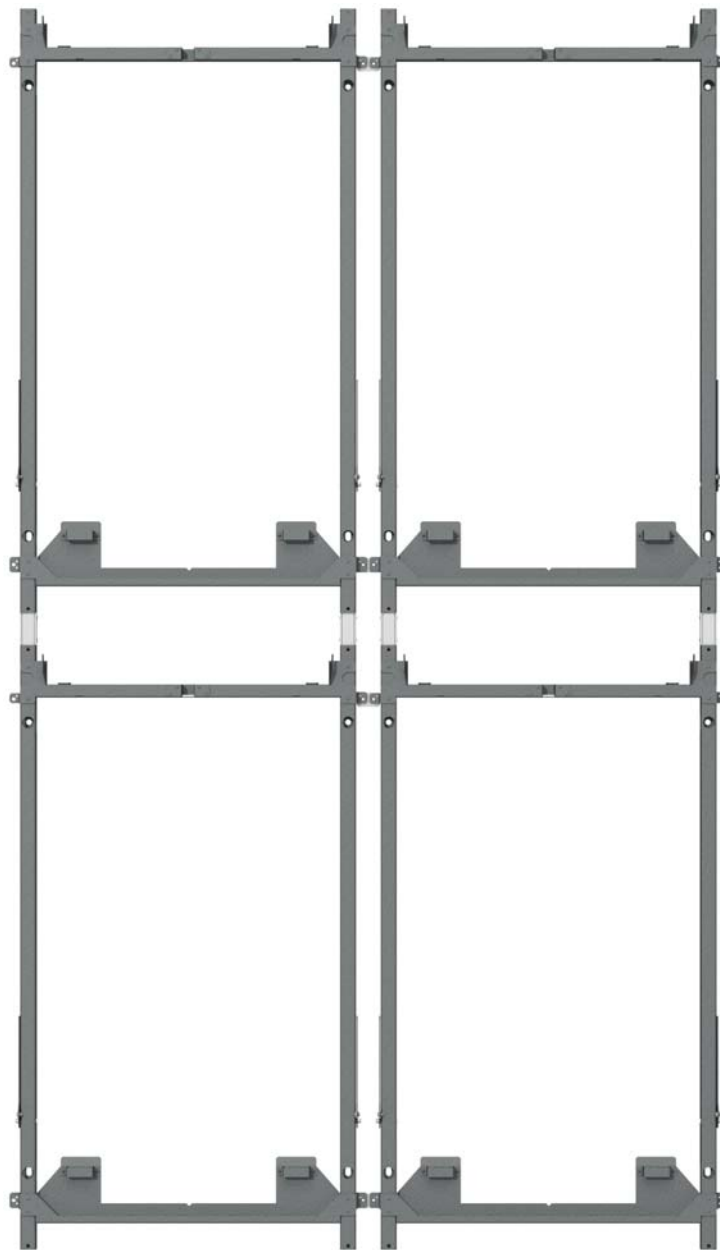

Note: This image is an example of a portrait mount 2x2 configuration.

EasyAxis mounts are designed to facilitate the thinnest profile LCD video wall. The combination of the mount plus the Matrix LCD module's "blade" design results in video walls that can measure 3.6 inches (91mm) in depth, screen to wall.

Off-Board Equipment and Components

To reduce heat issues and to make servicing of the video wall easier, there are two main Matrix components that are separate from the LCD module itself. The Quad controller modules and power supply modules can be housed in an equipment rack that is typically situated away from the video wall itself.

Quad Controller Module

The Quad controller module contains four microprocessors, each of which manages the video information flowing to one LCD module. The Quad controller module routes up to five digital source inputs to the LCDs. For more information about what the different LEDs on the front of the Quad Controller module mean, see "Quad Controller Status LEDs" on page 62.

Front View



Rear View

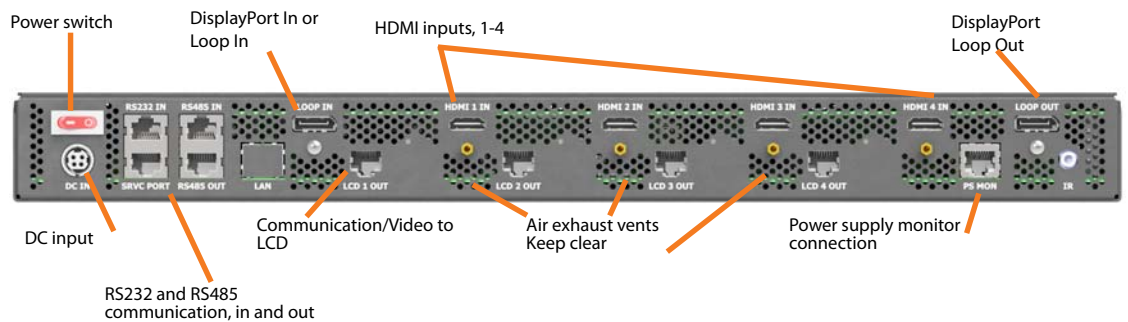

Power Supply Module

Front View

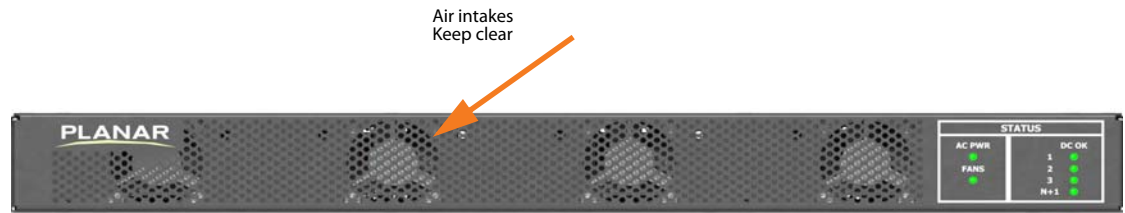

Rear View

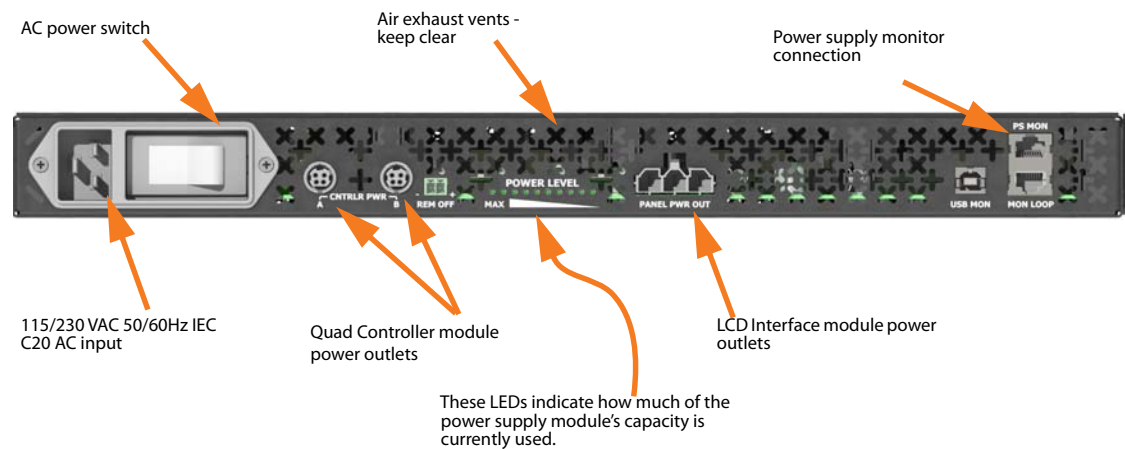

The Clarity Matrix with G2 Architecture utilizes a unique off-board power supply module. This power supply module can be conveniently placed up to 500 ft. away from the Matrix LCD module. It can power up to 2 quad controller modules and up to 8 panels with a single cable from the power supply module. The number of panels that can be driven off of a single power supply module will vary depending on the panel type and the distance in which you are running the primary power cable. The power can then be daisy chained to the number of panels specified by the configuration. The Clarity Matrix power module can be ordered to provide optional redundant power so that in the case of an internal power supply failure you will maintain operation with zero downtime.

Identifying your Power Supply Module Type

There are 2 different configurations of the Matrix G2 Power supply Module.

| Model | Description |
|----------|---|
| MG2-PS3 | Fully populated power supply module |
| MG2-PS3R | Fully populated power supply module with Redundant Option |

The label located on the Power supply module will tell you which model of power supply module(s) you have. You can also determine by the LED's on the front of the power supply module.

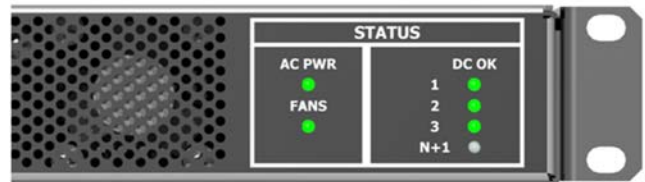
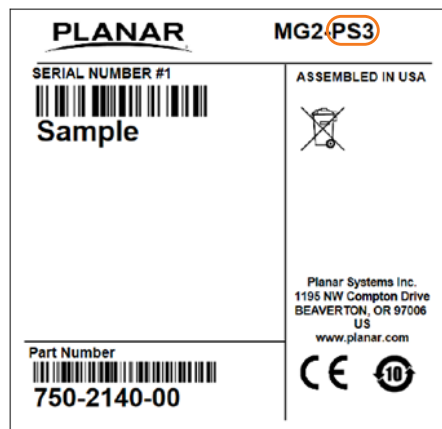

Image shows indicators for an MG2-PS3

Planning for your Power Supply Configuration

Planar has an online calculator <http://matrixcalculator.planar.com> that you should use to calculate exactly how many power supply modules you will receive for your particular configuration.

Installing a Clarity™ Matrix LCD Video Wall System with G2 Architecture

This section explains how to install a Clarity Matrix Video Wall. We suggest that you read this entire section before you attempt to install the wall.

Before You Begin

Make sure you have all the items in the following lists before you begin unpacking and installing your Clarity Matrix Video Wall(s).

Tools/Equipment List

Depending on your installation, you may need one or more of the following items:

- Drill and bits
- Nut drivers
- Pencil
- 3mm hex key
- M6 (#1/4-20) wrench
- String/string level
- Digital/laser level
- Ladders/lift
- Back brace
- Stud finder (if hanging LCD modules on a wall)
- Quad controller module address adjustment tool (included in your accessory kit)

Other Things You May Need

- LCD screen cleaner or LCD wipes - available at most electronics stores
- At least two capable people to lift LCD modules into place

Safe Handling of the LCD Modules

Very important notes below:

All Clarity Matrix panels are susceptible to damage through improper handling. It is important to take great care in how the units are unpacked, staged and installed. The packaging has been specifically designed to protect your LCD during the installation of the mounting system, so **they should be left in the package** until it is time for their installation.

Note: See "How NOT To Handle LCDs" on page 8 and "[How to SAFELY Handle the LCDs](#)" on page 9.

Use the handles provided to lift the units from the package. Using areas other than these features may lead to panel damage. You may support the bottom of the unit with your free hand, but most lifting should be done by the handles.

If you do *not* have an ERO enabled unit *do not* apply pressure to the front of the LCD, this pinching could break the glass or cause the glass to dislodge from the bezel.

If you must put the panel down, place it vertical to slightly tilting toward the back of the unit on one of the edges that has the narrower front bezel. Be sure the surface you are resting the panel on is flat and clear of any debris. *Concentrated points of contact will damage the LCD.* Resting on the thicker edge of the bezel will cause damage to the LCD.

If you must rotate the unit, *do not allow any weight to rest on the corner* of the LCD as this can cause damage. The corner where the two narrow front bezels meet is the most susceptible to damage. Tilting a unit toward the front may cause damage to the structure holding the glass in place.

Most LCD bezels are smooth, however some have features that can get caught on various objects and be damaged. Avoid clothing or other items which can snag on corners or edges.

Caution: *Do not* lay the panel on its face or back. This may cause the glass to become dislodged from the bezel and make it susceptible to falling out.

Plan Your Installation

You should have a detailed plan of how the Matrix wall is to be configured. Planar has an on-line calculator that can help estimate the architectural impact of your Matrix G2 video wall. It can calculate how many rack mount components you will receive, power consumption, heat load, dimensions, etc. You can find it online at <http://matrixcalculator.planar.com>.

Your plan should include calculations for the following:

- Floor/wall load. Make sure the floor/wall is strong enough to support the weight of the whole Matrix system.
- For passive cooling, we recommend a minimum of 8-10" of top clearance. This can be reduced if the LCD array is actively cooled.
- Ventilation and cooling requirements. Although most of the heating elements are not in the LCD itself, it is still important that you have proper cooling and ventilation for the entire Matrix wall and its off-board power supply modules.
- Plan your building power appropriately for your wall power consumption. See "Calculating DC Power Requirements and Component Heat Load" below for more information.
- To help your installation run more smoothly, it is highly recommended that you create a cabling diagram prior to installation.
- Cable runs - Account for how long cable runs need to be and where they will be routed. The following table shows the maximum length allowed for power and video cables.

| Cable Type | Maximum Length |
|-------------|--|
| Power Cable | 152m (500ft) Max (depends on wall configuration) |
| Video Cable | 60m (200ft) standard 100m (330ft) optional 152m (500ft) optional at reduced resolution |

Note: Long power cable runs from the power supply to the first panel may cause a voltage potential difference between the panels and the building ground. For a properly functioning system, the panels are meant to be isolated from ground where they are installed.

Calculating DC Power Requirements and Component Heat Load

The Clarity Matrix Video Wall uses power loop through management for the LCD components. The power supply modules convert AC power to 48V_{DC} that is distributed to the basic components of the system. There are 2 different power supply modules offered for use with the Matrix G2.

| Model | Total Output V _{DC} |
|-------------------------|------------------------------|
| PS3 / PS3R ¹ | 1200W |

¹The "R" denotes a redundant power supply module.

Note: Each power supply module is physically capable of powering up to 2 Quad Controller modules. (See also ["Planning for your Power Supply Configuration" on page 20.](#))

One of the most important points to consider is to determine the total power consumption for the LCDs and the necessary number of power supply modules to run the configuration. We recommend that you use the online calculator at <http://matrixcalculator.planar.com> for best results. You may use the table below and the calculation examples to help determine total power consumption, if you don't have access to the link above.

| Component | Model | Typical Power Consumption (W) | Maximum Power Consumption (W) | Max Heat Load at Component (BTUs/hr) |
|---------------------|------------|-------------------------------|-------------------------------|--------------------------------------|
| Power supply module | PS3 / PS3R | | 190 | 649.8 |
| Quad Module | All | | 65 | 205.2 |
| LCD | MX46HDS | 163 | 170 | 581.4 |
| | MX46HDU | 153 | 170 | 581.4 |
| | MX55HDS | 234 | 240 | 820.8 |
| | MX55HDU | 211 | 230 | 786.6 |
| | LX46HDS | 134 | 140 | 478.8 |
| | LX55HDS | 211 | 230 | 786.6 |
| | LX46S-3D | 223 | 230 | 786.6 |
| | LX55HDU | 152 | 165 | 563.5 |

When a wall configuration is ordered the correct number and type of power modules were defined. It is important to understand the power supply capabilities and how LCD type and quantity, cable distance, Quad modules and backlight setting can affect the overall performance. The power modules have been designed to provide a complete power solution to the Clarity™ Matrix LCD Video Wall System with G2 Architecture product, however in some cases it may make sense to isolate the Quad module power to optional power bricks that can be provided by Planar. Below are some examples of power configurations.

Example

The original parameters below were provided to Planar and the system was configured appropriately where a 1200W power supply was specified to drive the required six MX46HDS panels.

| Example MX46HDS | Original Specified Configuration | | Onsite Required Configuration | | Planar Recommended Configuration #1 | | Planar Recommended Configuration #2 | | Possible Option (Not Recommended) | |
|--------------------|----------------------------------|--------|-------------------------------|--------|-------------------------------------|--------|-------------------------------------|---------------------|-----------------------------------|--------|
| | | | | | | | | | | |
| Backlight Settings | 100 | PWR(W) | 100 | PWR(W) | 100 | PWR(W) | 100 | PWR(W) | 80 | PWR(W) |
| Panel Quantity | 6 | 924.8 | 6 | 924.8 | 5 | 770.6 | 6 | 924.8 | 6 | 828.7 |
| Quad Modules | 2 | 130 | 2 | 130 | 2 | 130 | 2 | 0 (Note 2 below) | 2 | 130 |
| Cable Length (ft) | 260 | 108.1 | 360 | 145.3 | 360 | 101.9 | 360 | 101.9 | 360 | 118.7 |
| Total Power | | 1162.9 | | 1200.1 | | 1002.6 | | 872.6 | | 1077.5 |

During the planning/install it was determined that the actual power cable run needed was going to be 360ft instead of the previously thought 260ft. As you can see the total power required for the onsite configuration the power output exceeds the 1200W power supply capability driven by the 2x power load the cable places on the system compared to before. There are a few options that can be followed to alleviate the problem with going over the specified 1200W that this extra 100ft will cause.

- 1 Reducing the number of panels on the power supply removes a significant amount of power load. The last panel in this case would be powered by a purchase of an 820W power supply and an additional cable run. A new electrical outlet may be required at the install site.
- 2 Removing the load the Quad modules place on the power supply will suffice in this instance as well. Purchased power bricks can be used independently to power the Quad modules allowing the 1200W power supply to handle the cable run and panels alone. A new electrical outlet may be required at the install site.

- 3 Reducing the backlight setting to an acceptable level is another option. This requires further consult with the factory to determine a proper value. Additionally, since the backlight setting is not locked and can be changed at any time there is a risk the value may be changed causing stress on the system and reduced lifetime or a non-functional system.

The cable power load is calculated using the following equation. Note: The cable resistance number is for Planar supplied power cables, if customer supplied cables are used, this number will need to be updated and may cause previous power calculations to be void. LCD power is the total panel power connected to the cable and is backlight dependent.

$$P_{(cable)} = (P_{(LCD)}/48)^2 * .00107_{(cable\ resistance)} * \text{desired cable length in feet}$$

The power supply comes with some added features to help installation and maintenance of the system.

- 4 During the installation, you can use the power meter located on the back of the power supply module to verify that you have correctly cable the video wall. The backlight intensity setting will affect the overall power load so make sure that you have adequate head room if adjusting the backlight intensity to near Max brightness. Conversely, you can lower the power level by reducing the backlight. If the Power level LED's are flashing that means that the system load is too much and needs to be re-cabled.



Power level is good and can add more panels.

Power level is good, but approaching limit

Power level at limit; lifetime may be affected.

- 5 There is a PS monitor and PS monitor loop input/output connectors. These are used to remotely monitor the PS health through a system connected to the master Quad module RS232 port. The power supplies should be connected as described in Placing Off-Board Module Equipment on page 44.
- 6 The power supply also comes with a remote on/off trigger that can be connected to a control system or a simple ON/OFF switch. This trigger will put the power modules in a standby mode and shut down all connected equipment. If more than one supply is in the system, it is required that the PS monitor cables are connected to all the power supplies in order for this function to work properly.

Installation Checklist

Use this quick checklist as a guide to ensure you have performed the installation steps in the correct order.

- 1 Unpack and install the LCD mount brackets.
- 2 Install Quad controller modules and power supply modules.
- 3 Run cables between LCD mount and brackets.
- 4 Install LCD modules.

Unpacking and Checking Accessories

Cabling and Installation of Power Supply Modules



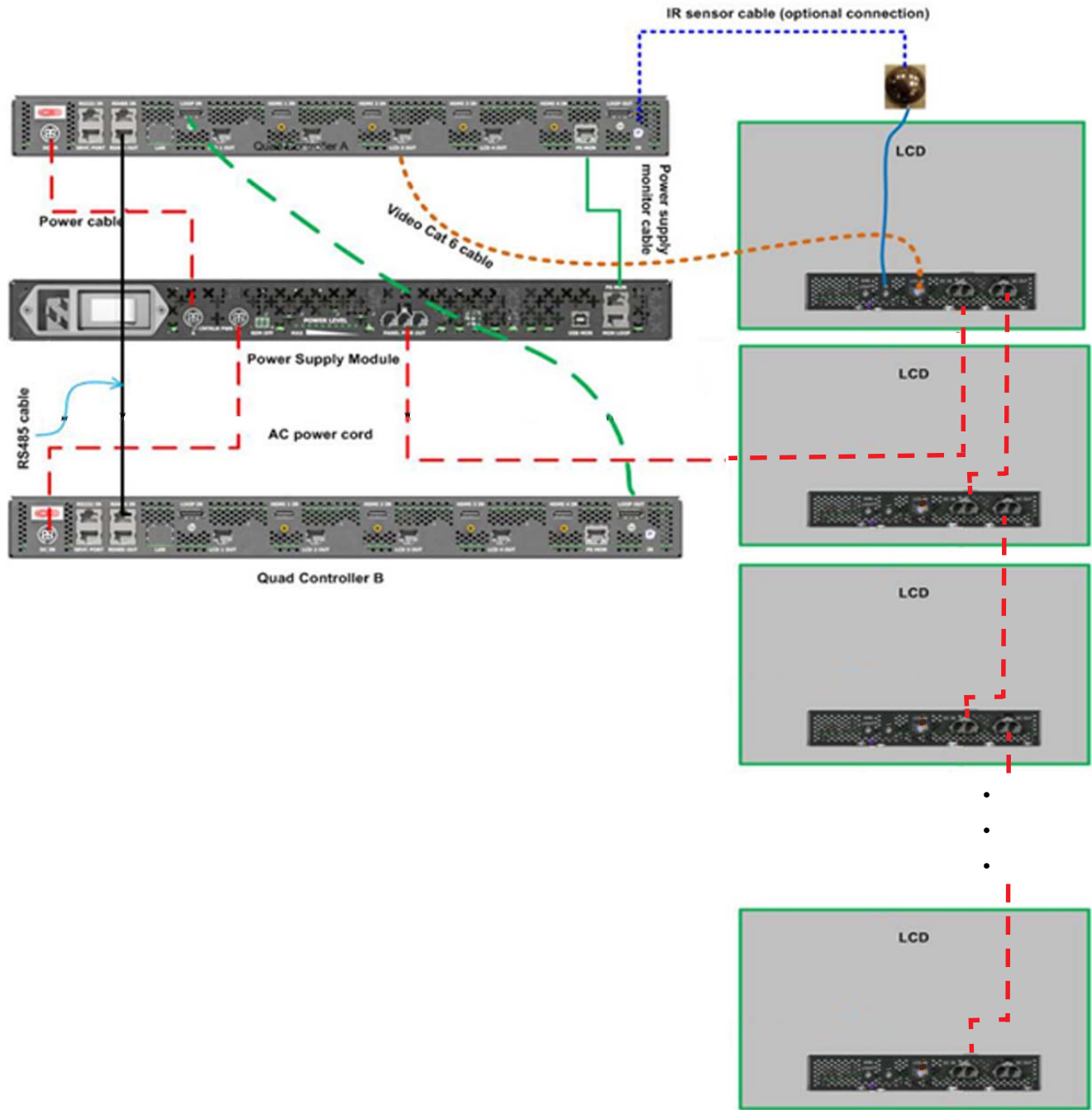

Proper system cable connection is paramount to ensuring optimum output from your configuration. Below is a typical connection scenario.

Note: Proper system cable connection is paramount to ensuring optimum output from your configuration. Below is a typical connection scenario.



Electronics Box



The following items are included in the electronics box.

| Part | Description | Per Quad/Power Supply | Picture |
|-------------------------------|---|-----------------------|---|
| Quad controller module | Routes up to five (5) digital source images to the LCDs. | 1 |  |
| Power supply module | Supplies power for up to eight (8) LCDs and two (2) Quad controller modules. Number of panel depends on model type and cable lengths. | 1 |  |
| RJ45 to RJ45 patch cable (1m) | One cable connects the Quad controller module to the power supply module. The other cable connects one Quad controller module to another. | 2 |  |
| Power cable (4ft) | Connects the power supply module to the Quad controller module. | 1 |  |

Note: It is highly recommended that you use the cable label maker to identify each cable before it is installed.

LCD Module Box

The following items are included in the LCD module box.



| Part | Description | Picture |
|------------|---|---|
| LCD module | 1 or 2 per box depending on your order. Caution: Do not remove the LCD from its case yet. |  |
| LCD mount | 1 or 2 per box depending on your order. |  |

When it is time to remove the LCD module, see "How to SAFELY Handle the LCDs" on page 9.

Accessory Box(es)

The following items are provided in the larger accessory box, which also contains the accessory kit box. The contents of this box are described below.





| Part | Description | Number | Picture |
|--|--|--|---|
| Vertical bracket | Secures the LCD mount. | Depends on configuration requirements. |  |
| Horizontal bracket (landscape) | Secures the landscape LCD mount. | Depends on configuration requirements. |  |
| Horizontal bracket (portrait) | Secures the portrait LCD mount. | Depends on configuration requirements. |  |
| AC power cable (3m) | Depending on your order, the cable will be for use in North America or Europe. | 1 per power supply module |  |
| Power cable (various lengths depending on order); standard cable may be replaced by optional self-terminated cable | Connects the power supply to a display. (These are plenum rated.)  PS end  LCD end | 1 per power supply |  |





| Part | Description | Number | Picture |
|---|--|-----------------------|--|
| Power cable (8ft); standard cable may be replaced by optional self-terminated cable | Loop-thru for power from one display to another.  Same at both ends | 1 LCD |  |
| DisplayPort cable (3ft) | Connects between Quad Controller and LCD module | 1 per Quad Controller |  |

Accessory Kit

The following items are included in the accessory kit, which is inside the larger accessory box.

| Part | Description | Number Included | Picture |
|--------|----------------------|-----------------|---|
| Gloves | Used to handle LCDs. | 2 pairs |  |

| Part | Description | Number Included | Picture |
|--------------------------------------|---|-----------------|---|
| Remote Control | <p>Note: To use the remote, you must aim it at the IR Sensor, not the LCD screen.</p> | 2 |  |
| Installation manual (on a USB drive) | Provides detailed setup and configuration information. (You are reading it now.) | 1 |  |
| IR sensor | <p>Connects to Quad controller module A or LCD Module A1. Mount in a convenient location near your wall. Typically, this might be near the master (A1) display.</p> <p>Length is 3m; can be extended up to 30m</p> <p>Note: Keep in mind that you need to point the remote control <i>at the IR sensor</i>, not the display.</p> | 1 |  |
| Remote switch | Plugs into Power Supply; add your wiring to turn on/off all Power Supply Modules. | 1 per wall |  |

| Part | Description | Number Included | Picture |
|--|---|---------------------------|---|
| Cable labels | Used to help you identify each cable. | 1 dispenser of 150 labels |  |
| 150mm assembly and alignment tool | Used to align modules. | 2 |  |
| 270mm assembly and alignment tool | Used to align modules. | 2 |  |
| Quad controller module address adjustment tool | Used to set addresses of Quad controller modules. | 2 |  |

Optional Planar-Supplied Accessories

Make sure you have the following optional Planar-supplied items as needed to complete your installation:

- Curved brackets
- WallNet (Integrated WallNet is an option for the Quad Controller)
- Wall adapter bracket (see "Wall Adapter Bracket" on page 222)
- Floor stand
- Outer edge/rear cosmetic trim (see "Cosmetic Trim" on page 225)
- RS232 cables to link an external controller to the Quad controller module
- Cat 6 – (STP video cables) Length varies per wall depending on configuration requirements and your sales order.
- Power cable - Connects the power supply module to the LCD. Length varies per wall depending on configuration requirements and your sales order.
- Bulk cables for on-site termination. See "Matrix Drawings" on page 180 for detailed terminal information.
- Separate AC power supply to power the Quad Controllers directly.
- Ambient light sensor
- MultiTouch system

See "Installing Optional Accessories" on page 235, if you have these.

Note: For MultiTouch systems it is highly recommended that the wall installation guidelines for flatness be followed for best performance.

Wall Installation

Before you start building your wall, keep the following points in mind:

- A structure that is plumb and flat will greatly reduce issues with mounting and alignment of the Matrix system.
- Brackets are to be installed first - do not remove LCDs from their boxes until the entire wall of brackets is installed, level and plumb.
- When hanging the mounting bracket and displays, start with the center and work out and up.
- After each row of brackets and displays is built, check it for level and plumb.
- All brackets in a row should be level with the bracket next to it within $\pm 0.1^\circ$. Each bracket should be square with the level surface by $\pm 0.05^\circ$. Bracket wall planarity should not exceed $\pm 0.5\text{mm}$. For larger walls, we recommend you assure that the accumulation of tolerances will not prevent you from positioning the LCD panels.
- It is important that you check communication between the LCD modules as you build each row! This will help minimize changes once your wall is fully installed.
- For optimal product performance, maintain components within temperature specifications. Occasional temperatures out of specification are acceptable for a short period of time.
- For touch walls, ensuring the wall is flat will greatly improve performance.

Wall Installation Options

There are three main types of Matrix installations:

- Standard installation - mounted to a wall (see "Mounting Brackets to a Wall" on page 37)
- Column floor stand - maximum of 2.15m (7 feet) without additional support
- 2 x 2 free-standing mount (46L only)

Installing the LCD Mount Structure

EasyAxis mounts are designed to facilitate the thinnest profile LCD video wall. The combination of the mount plus the Matrix LCD module's "blade" design results in video walls that can measure 3.6 inches installed depth, screen to wall.

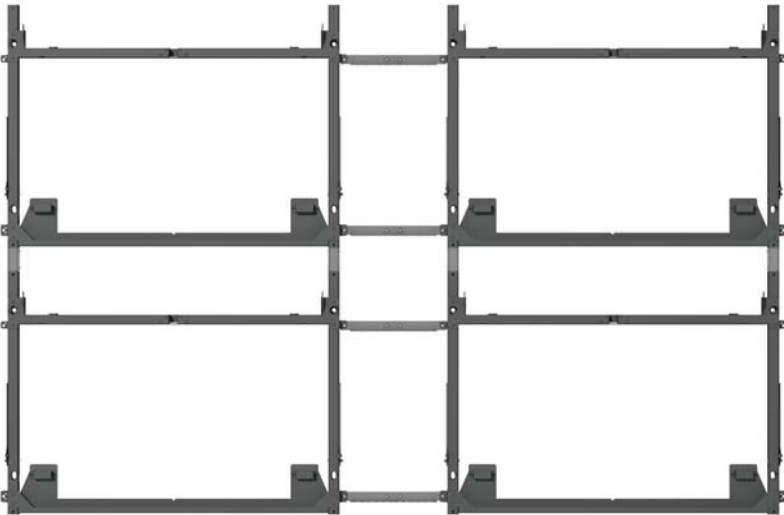

Landscape Mounting

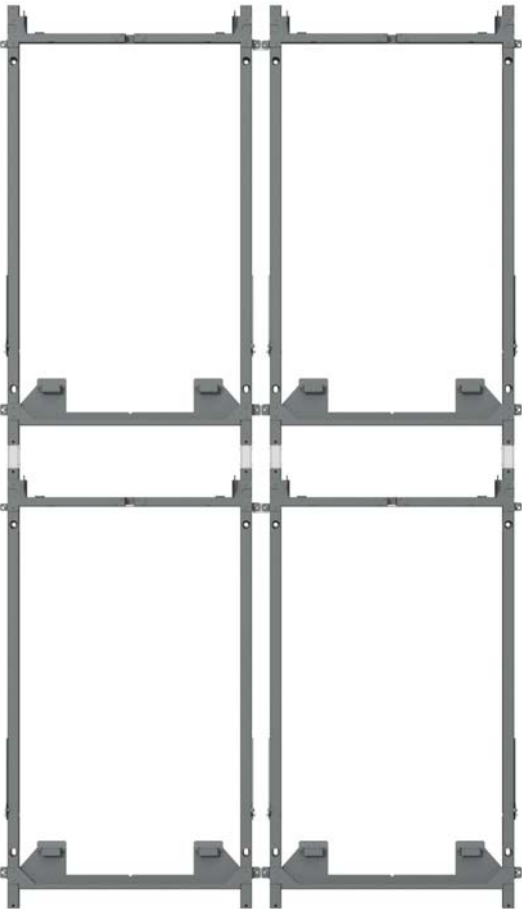



Portrait Mounting



Mounting Brackets to a Wall

The basic concept of mounting brackets to a wall is to start from the center of the wall and build out the first row. It is recommended that the wall is a flat surface. If the wall is not flat, you will need to insert shims in between the LCD mounts and the wall.

Caution: For whatever structure is used to mount the LCD wall, be sure that it is sufficiently engineered to handle the weight of the LCDs.

There are three standard brackets that are used for wall installation. An optional stud adapter bracket (landscape only) can also be used if you are not mounting to plywood and want to mount to studs in a wall.

| | |
|--------------------------------|---|
| LCD mount |  |
| Horizontal bracket (landscape) |  <p>Note: If you have protective optically bonded glass, the brackets used will be yellow.</p> |
| Horizontal bracket (portrait) |  <p>Note: If you have protective optically bonded glass, the brackets used will be yellow.</p> |

| | |
|--------------------------------------|---|
| Vertical bracket |  <p>Note: If you have protective optically bonded glass, the brackets used will be yellow.</p> |
| Wall stud adapter bracket (optional) |  |

Installing Brackets on the First Row of a Fixed Wall

- 1 Remove the LCD mounts from the LCD module boxes. Set aside the boxes with the LCD modules still in them for later installation. Unpack the horizontal/vertical brackets and hardware from the wall accessory box(es).
- 2 Use the drawings that correspond to your product. (See "[Matrix Drawings](#)" on [page 180](#).)
The LCD mounts are designed to mount with either four M6 or #1/4-20 hardware and a washer.
- 3 Determine the vertical center of your wall and then find the location of the closest display to this position.
- 4 Mark on the wall vertically where the center of that display will be. Using a pencil, make horizontal line where the bottom center bracket will be. Use a string or laser level to continue the line for the rest of the desired wall. This will help maintain a level row as you progress installing the LCD mounts.
- 5 To pre-determine the proper mount points for the LCD mount, measure out or use a template. Then loosely attach the LCD mount.
- 6 Using a level (a digital one is highly recommended), level the bracket as you keep in mind the string or laser level at the bottom.
- 7 Align the v-shaped notch on the LCD mount with the desired center of the LCD (this is done for the first bracket only).

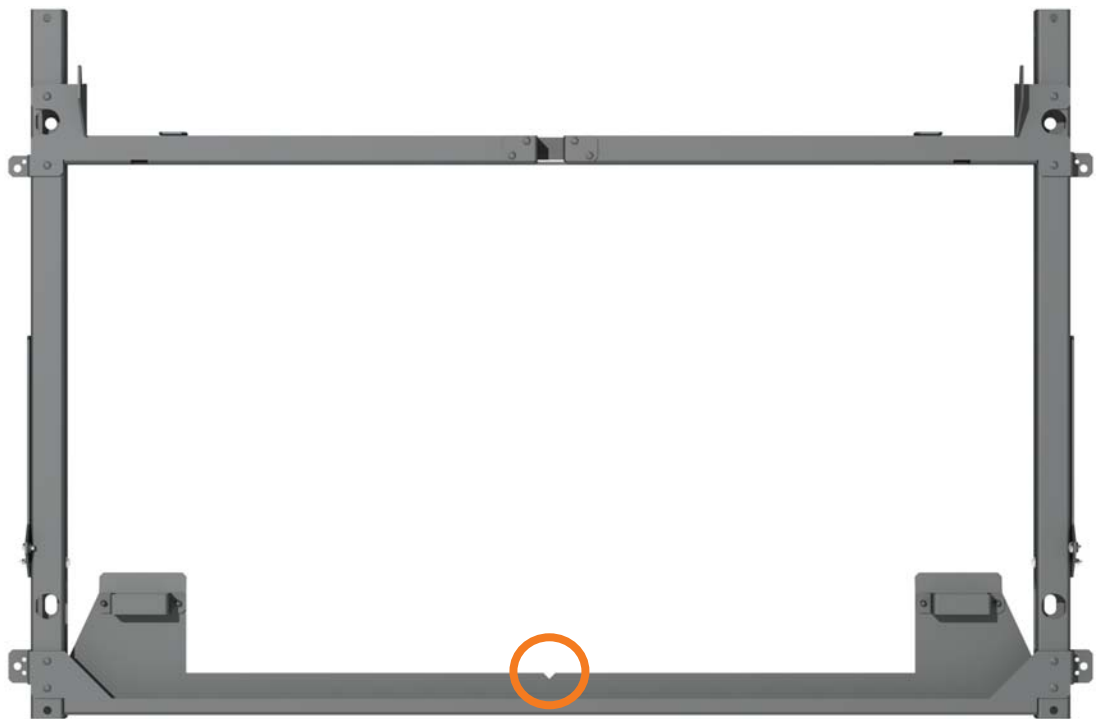

Note: The mount shown is for a Landscape installation.



Note: The mount shown is for a Portrait installation.

8 Tighten the screws as necessary.

Note: Be sure that as you tighten the screws, the mount is flat. If it is not, use shims near the mounting points as necessary.

- 9** Attach horizontal brackets to the LCD mount that will attach to the next LCD mount you want to install.
- 10** Repeat steps **5-9** for the first row. Be sure to level all brackets with respect to the first mounted bracket.
- 11** Using a digital level, make sure the first row is level. All brackets in a row should be level with the bracket next to it within $\pm 0.1^\circ$.

Installing Brackets on Subsequent Rows

- 1 Starting again in the middle of the wall, use two screws to mount vertical brackets to each LCD mount in the first row.

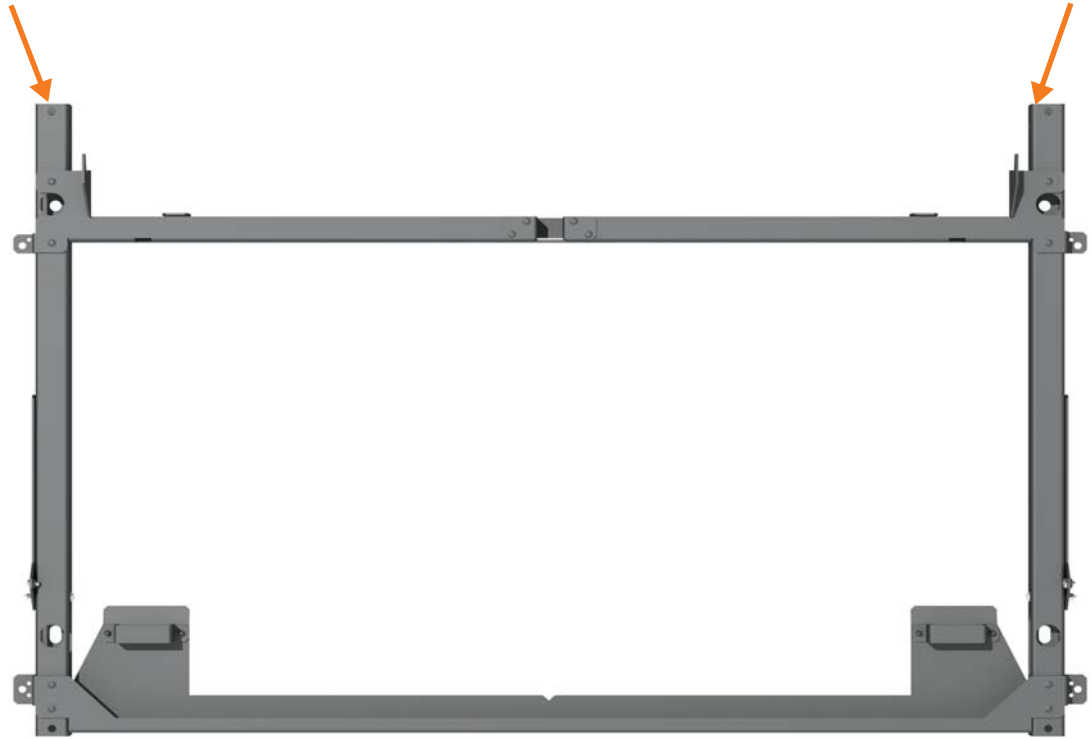

- 2 Install all the LCD mounts in this row and attach them with the two screws to the vertical brackets.
- 3 Loosely attach LCD mounts to the wall.
- 4 Install the horizontal brackets. As you add each new set of brackets, make sure the row continues to be level and plumb. Tighten the screws that attach the LCD mount to the wall. Repeat this process for all of the LCD mounts and horizontal brackets in this row.

Note: Be sure that as you tighten the screws, the mount is flat. If it is not, use shims near the mounting points.

- 5 Using a digital level, make sure the row is level and the columns are plumb.
- 6 Repeat steps 1-5 for each row that you add.

Routing Cables

Before you install LCD modules, you need to route cables through the LCD mounts. Notches on the horizontal brackets make routing cables easier.

As you configure your wall, it is important to think about how it will be set up and where the master (A1) display should be located. This does not need to be the upper left display in an array, but rather should be in a location that will be easily accessible. For example, if you have a 4 x 4 wall and it is easier to see on-screen menus in a lower row, the master (A1) display should be set up there.

Note: It is possible to change the master display after a wall is built. However if an IR is used for the wall or an ambient light sensor is used, it must be connected to the A1 display panel in order to function properly.

- 1 Route power and video cables between the LCD mounts and then through the side hole near the bottom of the LCD mount. Place cables in the LCD mount channel so they are out of the way.



Best practice for routing heavy power cables.



Note: We recommend that you use a cable label-maker to identify each cable before it is installed.

Note: We recommend that you initially leave 0.5m (2 ft) of cable beyond the LCD mounts to ease connection. The excess cable can be pulled back as the panels are put into place.

- 2 Route power and video cables from the brackets to the off-board equipment for the entire wall. For ease in troubleshooting and configuration, we recommend that you cable your video cables together in “clusters.” Use one Quad controller module and (up to) four LCD modules in each cluster. Pick a rectangle of LCD modules and connect them all to the same Quad controller module. For ease of turning on displays as you install, we recommend that the power cables be routed from the bottom center out whenever possible.

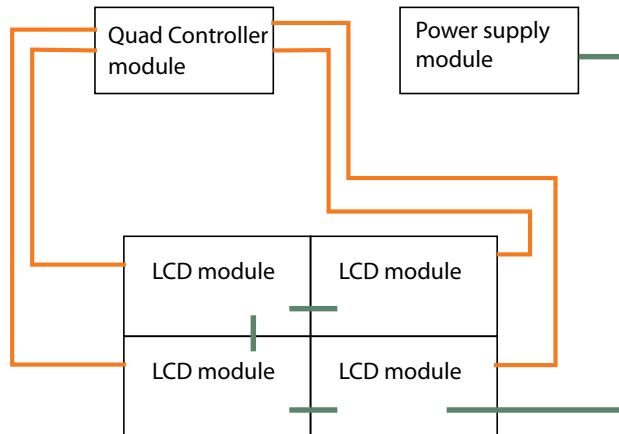

Note: For most configurations of the wall, you can choose any arrangement of rectangles. But for configurations that will have multiple sub walls, you will want to plan your configuration before choosing your clusters of LCDs. If you’re not sure how to arrange the clusters, choose a 2 x 2 configuration. See ["Understanding Wall Configuration" on page 119](#) for more information.

Note: Keep in mind that you need to point the remote at the IR sensor, not toward the screen you want to control.

Placing Off-Board Module Equipment

Before you install your LCDs, first place your Quad controller modules and power supply modules in the area where they will be installed.

Plugging In Cables to the Off-Board Modules

Once the modules are placed, complete the following steps.

- 1 For each Quad controller module, plug the CAT 6 video cables from the LCDs into the LCD Out connections. (HDMI connections are made later in the connecting sources section.)



- 2 For each Quad controller module, plug one end of a power cable into the DC IN connector on the Quad controller module and the other end into the CTRL PWR connector on the power supply module.



- 3 For all the power supply modules, plug one end of the power supply monitor cable into the PS MON connector of the Power Supply module and the other end into the MON LOOP connector of the next power supply module. Plug the final PS MON from the power supply into the PS MON on the Master Quad Controller.



- For each power supply module, plug one end of the AC power cable into the power supply module and then the other end into the wall outlet.



Note: The Quad Controller Module may have an optional device known as WallNet that allows remote monitoring of the status of various components in the wall. WallNet is only required on one Quad Controller Module to monitor up to 64 displays. See document 020-1260-00, User Guide, WallNet2, Matrix G2 for detailed operation instructions.

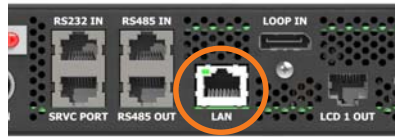

WallNet connection

- For each power supply module that will plug into an LCD, plug in one end of the longer power cable into one of the 48V connectors on the power supply module.



Rear of Quad Controller module

Connect one end of the longer power cable into the 48V "Panel Power Out" connection. The other connects to the first in a chain of LCD modules.

Rear of power supply module



AC power to wall outlet

Power to Quad Controller module

Power to LCD

Installation Considerations; Tips for Adjusting Walls

The basic concept of installing LCD modules in the wall is similar to installing brackets. Start from the center of the wall and build out the first row. As you complete each row, ensure the entire row is level.

Caution: It is important that you check communication between the LCD modules as you build each row! This will help minimize changes once your wall is fully installed.

While the EasyAxis™ mounts are designed to align the LCDs with one another, take note of LCDs that may not match in overall size to the majority of LCDs. While most panels are the same size, there are some that can be larger or smaller by a small amount. When this is the case, it may be difficult to align the seams of all units exactly.

For small walls, these larger or smaller panels can easily be moved to the outside corners (top, sides), depending on which dimension is larger or smaller than the others.

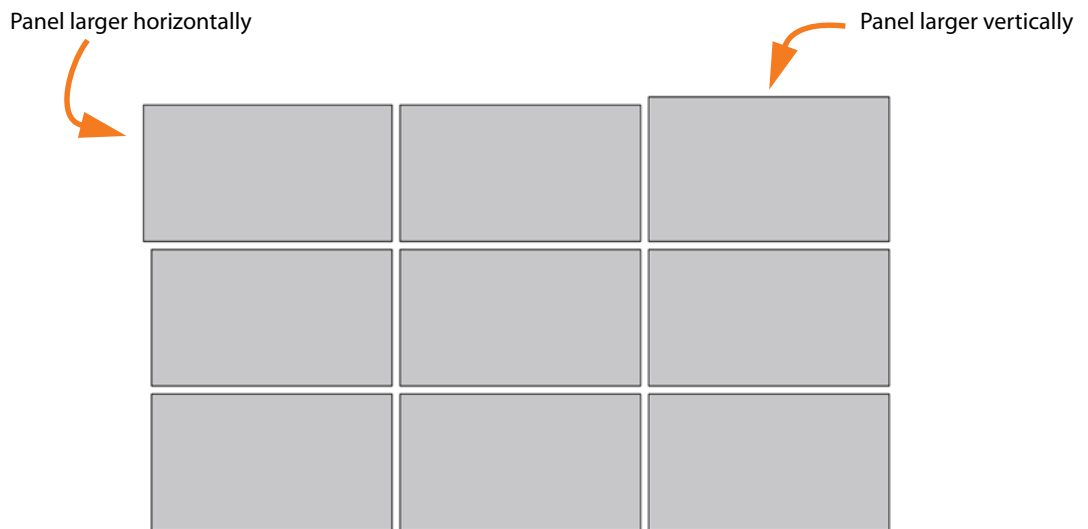

Panel sizes and spacing are exaggerated in this diagram.

For larger walls, it may be necessary to group these units into rows or columns throughout the installation or at the edges.

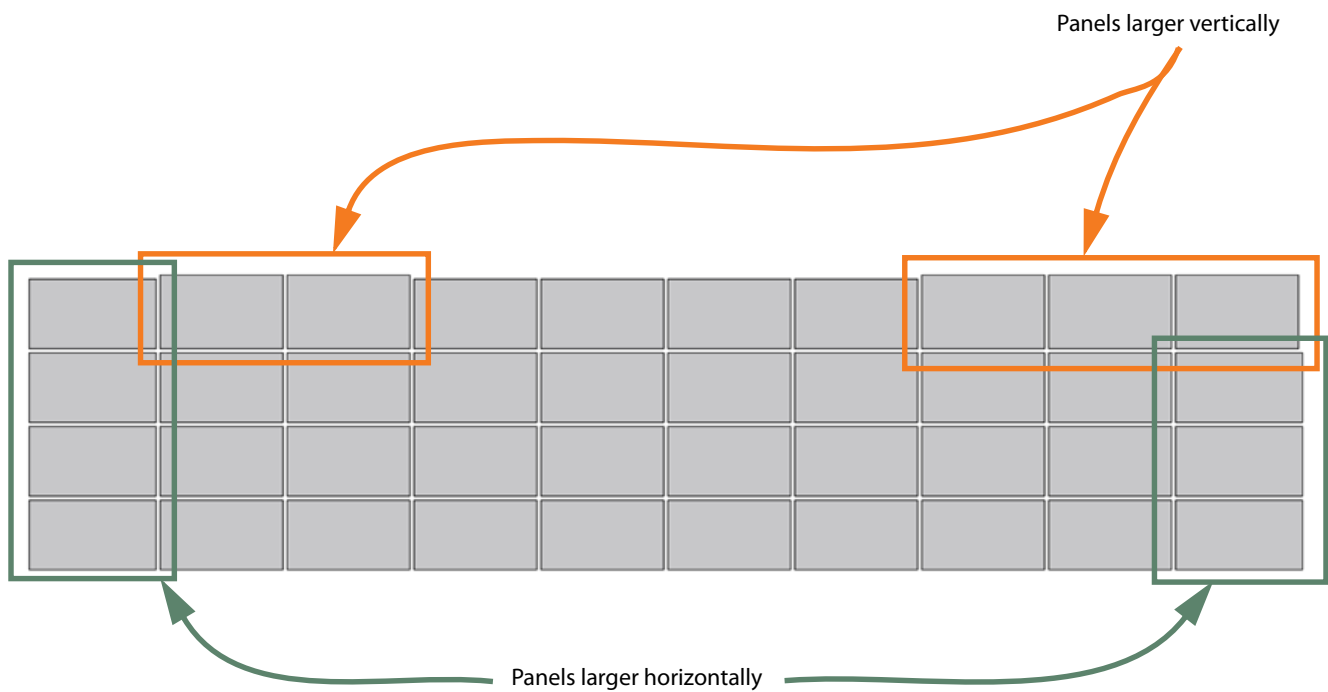

Panel sizes and spacing are exaggerated in this diagram.

Note: It is important to install displays so that there is a physical gap between units. Due to thermal expansion, module dimensions will grow after they have been turned on. This growth should stop after about one hour depending on ambient conditions. If the wall was installed without a proper gap between units, this can lead to the modules contacting one another and creating stress on the LCD. This stress can lead to bright spots or non-uniformity where the contact occurs and possibly damage to the LCD itself. When the units are turned off the LCD's will contract to their original size and the gaps will return to their installed size.

As with the mounts, LCDs should be installed in the middle of the wall first and then added outward from there. This enables use of the adjustments by splitting the tolerance build-up to the left and right.

Installing the First or Bottom Row

As you plug in and install each LCD module, turn it on to verify it works properly and to ensure that the position sensor is active. See step 9 of this section for more information.

Note: Wearing the provided gloves will prevent smudges that would need to be cleaned later.

- 1 Remove the LCD that you want to install from the LCD shipping box.
- 2 Remove the LCD from the bag and then remove the mylar sheet and tape from the LCD module. *Be careful when removing the tape so you don't damage the bezel.*
- 3 *Two* people should lift the LCD into place. Each person should put one hand on the handle of the back of the display and one hand on the bottom of the display.



This picture shows an MX46 Landscape installation.

Caution: Be careful to limit contact with the thick edge of the bezel on the LCD, as electrical connections beneath can be easily damaged. Avoid resting the LCD on the corners, as doing so can cause damage. If the LCD needs to be rested against a surface, it should be rested face out and on the LCD edge that has the thinner bezel (LCD bottom surface).



Correct position
All four corners touching a solid
surface
Angle no more than 10° from
vertical



Incorrect position



Never rest the LCD on a corner!

- Starting in the middle of the wall, slide the horizontal support pins on the back of the LCD into the notch of the LCD mount. The LCD module is now in the pre-service mode position.

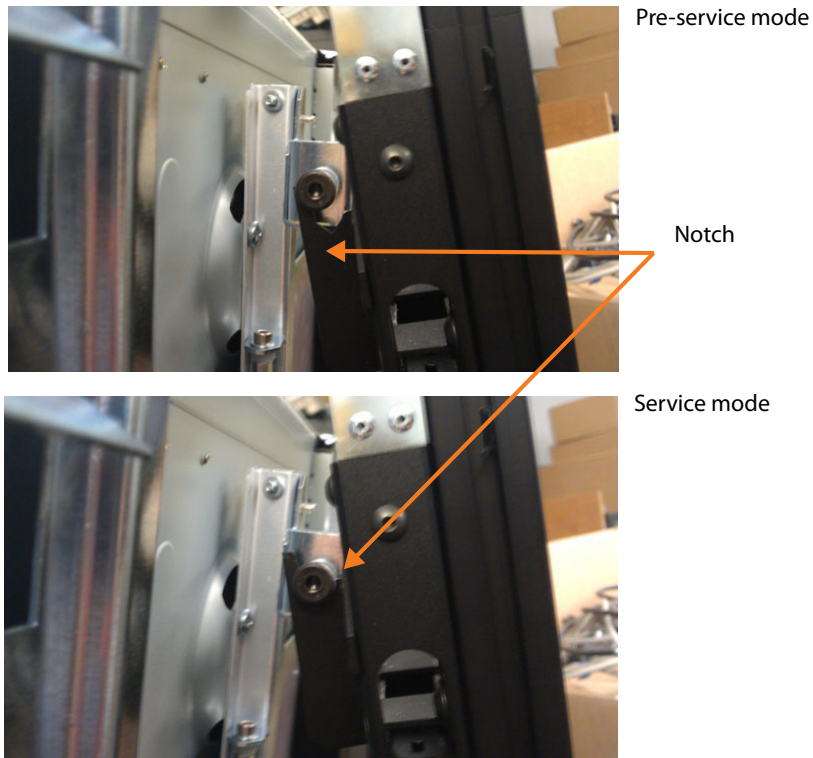

- Connect the Cat 6 video cable from the Quad controller module to the VIDEO connector on the bottom of the LCD.

Note: About connecting power supply cables: The power for one of the displays will come directly from the power supply module. Then power for the next display can be looped out of this first one into the second one. The order in which you connect these does not matter.

Note: Disconnecting power from a panel will disconnect power from any panels connected down the power chain.

- 6 Connect the power cable from the power supply module to the power connector on the bottom of the LCD. The power cable may come directly from the power supply or from another LCD's DC Out.

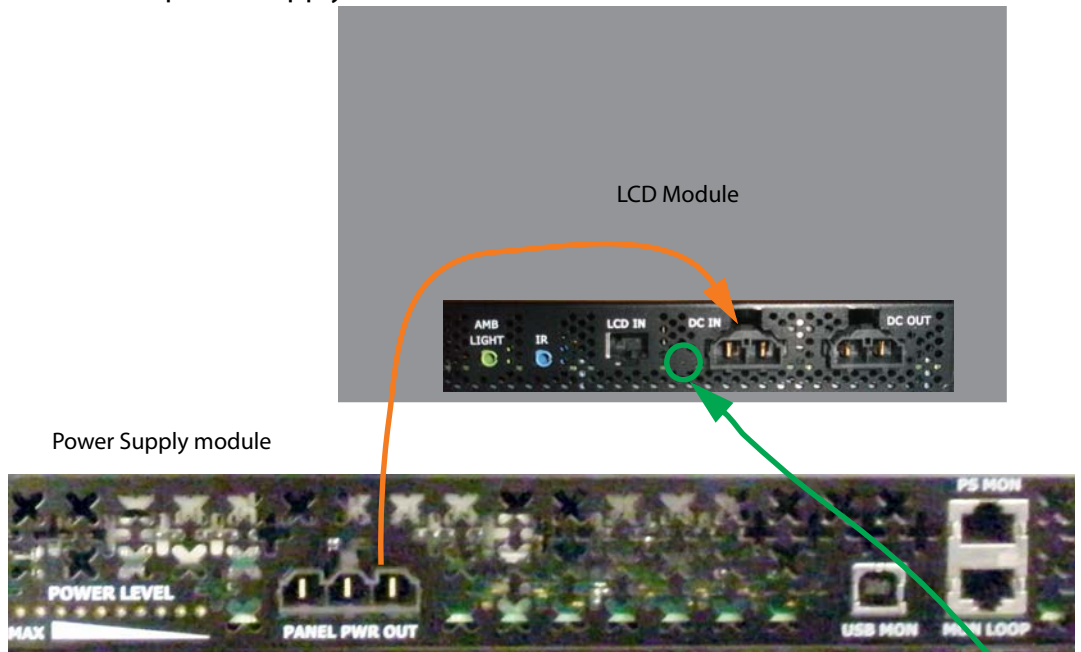

- 7 Turn on the power supply and the Quad Controller modules. Make sure picture information is flowing in the video connection; look for the flashing green light between the LCD IN and DC IN connectors.

- 8 Slightly lift on the handles and move the panel toward the mount. Once the panel cannot move toward the mount further, the panel can be lowered so that the adjustment cams slip into their nests.

Landscape installation - Slide down and into position

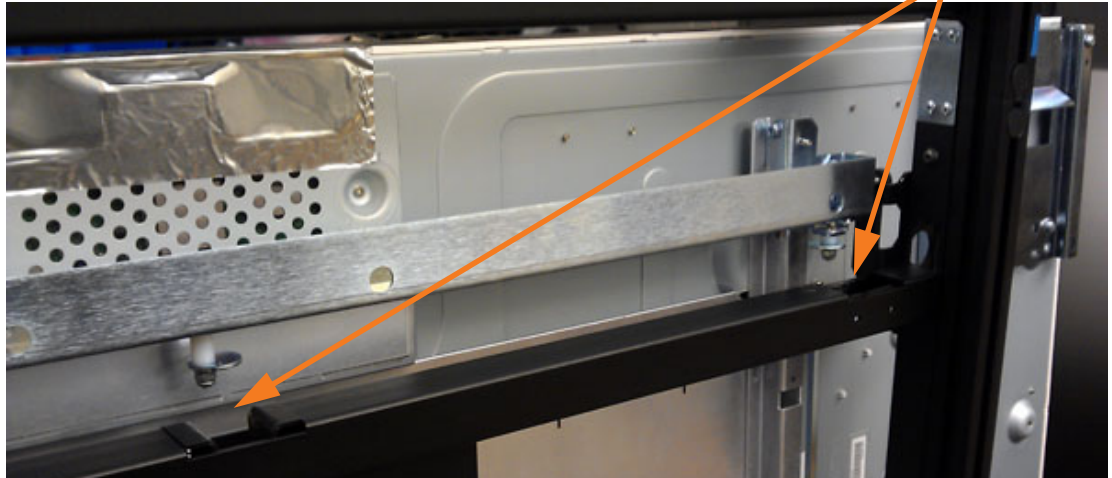

Portrait installation - Slide down and into position



Note: If the display is not seated properly, make sure the x-axis and z-axis adjusters are seated in the correct positions. (See steps **16-17** of this section.)

- 9 Verify that the position sensors (see "Mounting the IR Sensor" on page 57) are working by displaying the on-screen menus on the LCDs. For Landscape installations, the first LCD on the left in the row should always show the display ID of 1:1. For Portrait installations, the first LCD on the right in the row should always show the display ID of 1:1. As you build the row out, the left (Landscape) of the two numbers on each LCD should show an incremental number. In the first example below, you would expect to see 1 in the far left

LCD, 2 in the next one, etc. In the second example, you would expect to see 1 in the far right LCD, 2 in the next one, etc. Each number must also be unique. If you see a duplicate number or no information at all, check your cabling to make sure everything is properly connected and all of your modules are turned on.

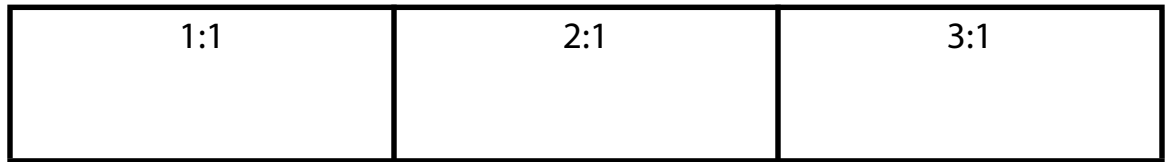

Landscape configuration.

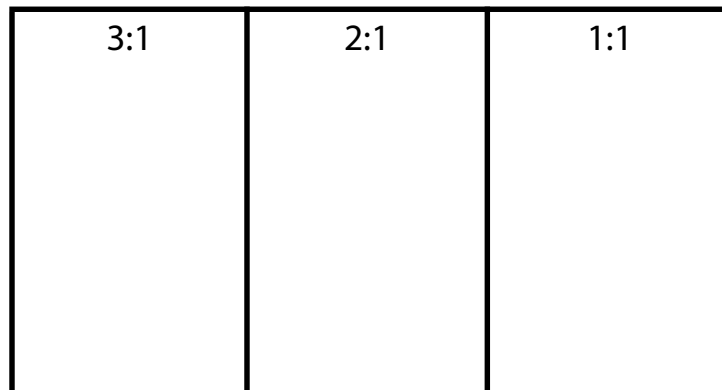

Portrait configuration.

- 10** For displays in the same row, make sure they are in a straight line using a digital level. Use this level to ensure the displays are plumb (true vertically for both sides and the front) and aligned from display to display. While the displays will be set to a nominal position prior to shipment, you might need to make minor adjustments, which are described in the following steps.
- 11** Each LCD module will come from the factory in the nominal position. However, due to installation and manufacture tolerances, adjustments to the module position may be required.

- 12** Starting with the center display, make sure it is level/parallel with the brackets. If it is not, use the two y-axis adjusters (one on each side) to accomplish this. Leave the other adjusters in their nominal positions.

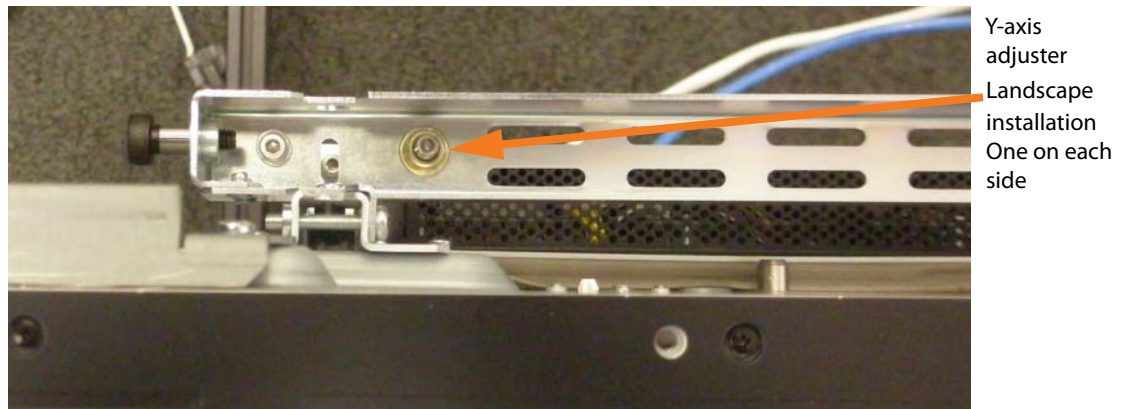

- 13** For the next display in the row, repeat steps **1-10** and then continue to step **14**.
- 14** When the next display in the row is installed, use the y-axis adjusters to level the display just as you did with the previous one.
- 15** If the displays are not level with each other, fine-tune the y-axis adjusters of the last installed display until it is level with the rest of the displays in the row.
- 16** Adjust the top and bottom z-axis adjusters in each corner of the last installed display until it is flush with the display next to it.

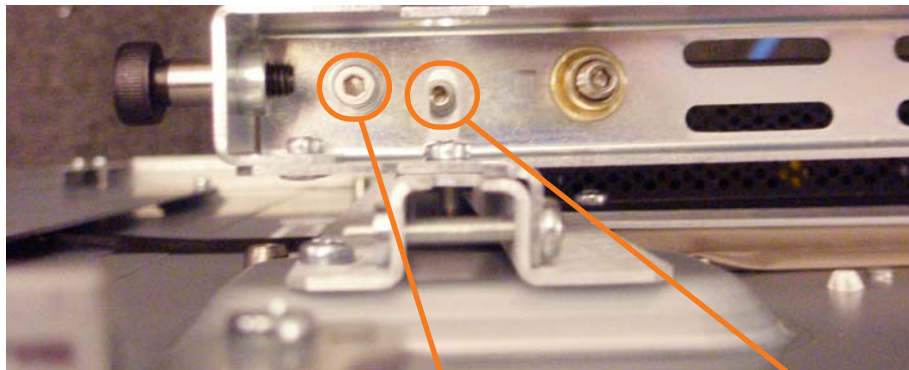

Portrait installation - Top Z-axis adjuster

Bottom Z-axis adjuster

There is a pair of Z-axis adjusters on each side.

- 17 Adjust the x-axis (in the middle of the support bar) of the last installed display so there is a 0.38mm gap (approximate thickness of a business card) between the displays.

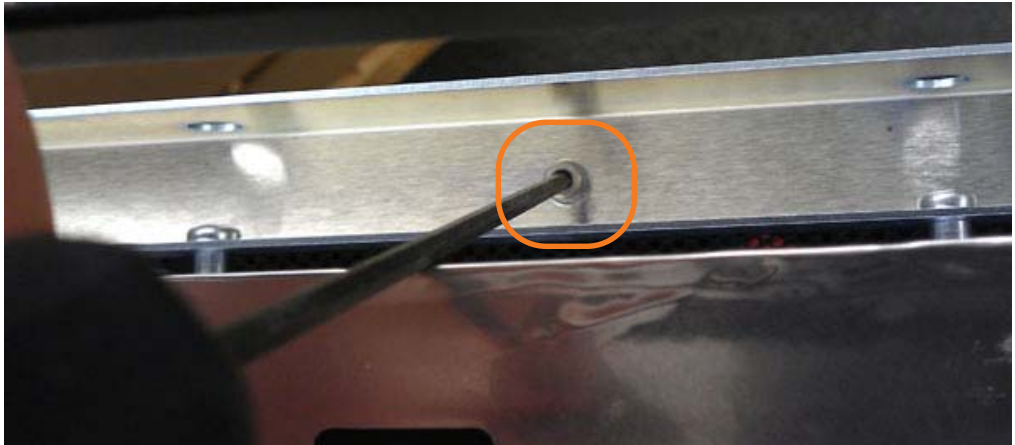

- 18 If the gap is tapered, you can make slight adjustments to the y-axis to correct this. This could be one or both displays that have the taper. Keep in mind if you adjust too far out of level, it can cause issues with the alignment of subsequent displays.

Note: A slight waviness in the gap is typical.

Installing Second and Subsequent Rows

- 1 Starting at the center display of the next row that you want to install, follow steps 1-8 of "Installing the First or Bottom Row" on page 48.

Caution: Depending on how the previous row was adjusted, when placing one display on top of another display, be sure to avoid contact between the displays. Damage may occur from the upper displays banging into or resting on the lower displays.

- 2 Verify that the position sensors are working by displaying the on-screen menus on the LCDs. For Landscape installations, the first LCD on the left in the row should always show the display ID of 1:1. For Portrait installations, the first LCD on the right in the row should always show the display ID of 1:1. As you build the row out, the left (Landscape) of the two numbers on each LCD should show an incremental number. In the first example below, you would expect to see 1 in the far left LCD, 2 in the next one, etc. In the second example, you would expect to see 1 in the far right LCD, 2 in the next one, etc. Each number must also be unique. If you see a duplicate number or no information at all, check your cabling to make sure everything is properly connected and all of your modules are turned on.

Check the number on the left when building a row.

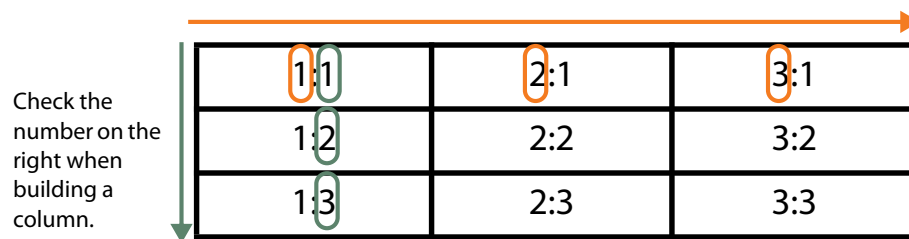

Note: Landscape configuration.

Check the number on the left when building a row.

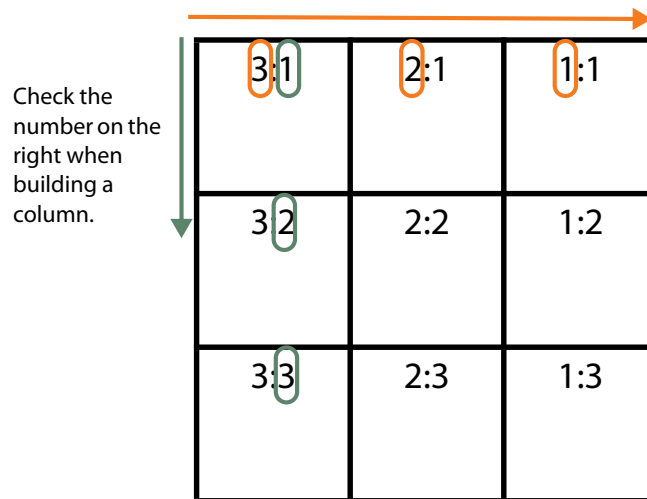

Check the number on the right when building a column.

Note: Portrait configuration.

- 3 Make sure the first display in the row is plumb with the display below it using the x-axis adjuster.
- 4 Using the y-axis adjusters, set the horizontal gap between the displays at 0.38mm (approximate thickness of a business card).
- 5 Adjust the z-axis corners of the last installed display until it is flush with the display next to it. Depending on the adjusted corner, this may require that the display be put in service mode. The alignment of the bottom corners might need to be re-adjusted as each new display is installed in the row.
- 6 Repeat steps 1-5 of this section to install subsequent displays in this row.
- 7 When you are finished, check the wall one more time to make sure the display IDs are in the correct order. Use the example above as a reference.

Mounting the IR Sensor

Before you mount the IR sensor, keep the following points in mind:

- Because most menus will be controlled on the master (A1) display, it is suggested that you mount the IR sensor near this display.
- No matter which display a menu is on, you will still need to point the remote towards this one IR sensor that controls the entire wall.

Connecting the IR Sensor

Connect the IR remote sensor to Quad controller module A or to LCD module A1. See the diagram on page 27 for a visual example of this connector location.

Mounting the Ambient Light Sensor

The ambient light sensor is an optional module used to change the brightness of the displays based upon the light conditions of the room where the wall is located. The OSD contains the software setup for this sensor and can be manipulated to give desired results. For best results, it is important to locate this sensor in a position which best typifies the changing ambient light—sunlight, overhead lighting—conditions seen by the front of the installed wall. Do not mount it behind a wall or in a place where there is no change in ambient light, because no change in brightness will occur if the sensor is unable to detect changes in ambient light. For a properly setup system, the wall will increase or decrease its brightness when the ambient light intensity changes.



RS485 Quad Module Connections

Use the RS485 cables to connect the RS485 Out of each Quad controller module to the RS485 In of the next module. The order of the modules does not matter. You do not have to complete the loop - the RS485 In of the first module will remain empty, as will the RS485 Out of the last module. Unlike other Planar Clarity wall products, these connections must be made, even if you will not be controlling your wall through RS232.

Checking Your Connections

Below is a diagram of a basic configuration. This illustrates which cables are connected where. Use this to make sure you have correctly made all of the basic connections.

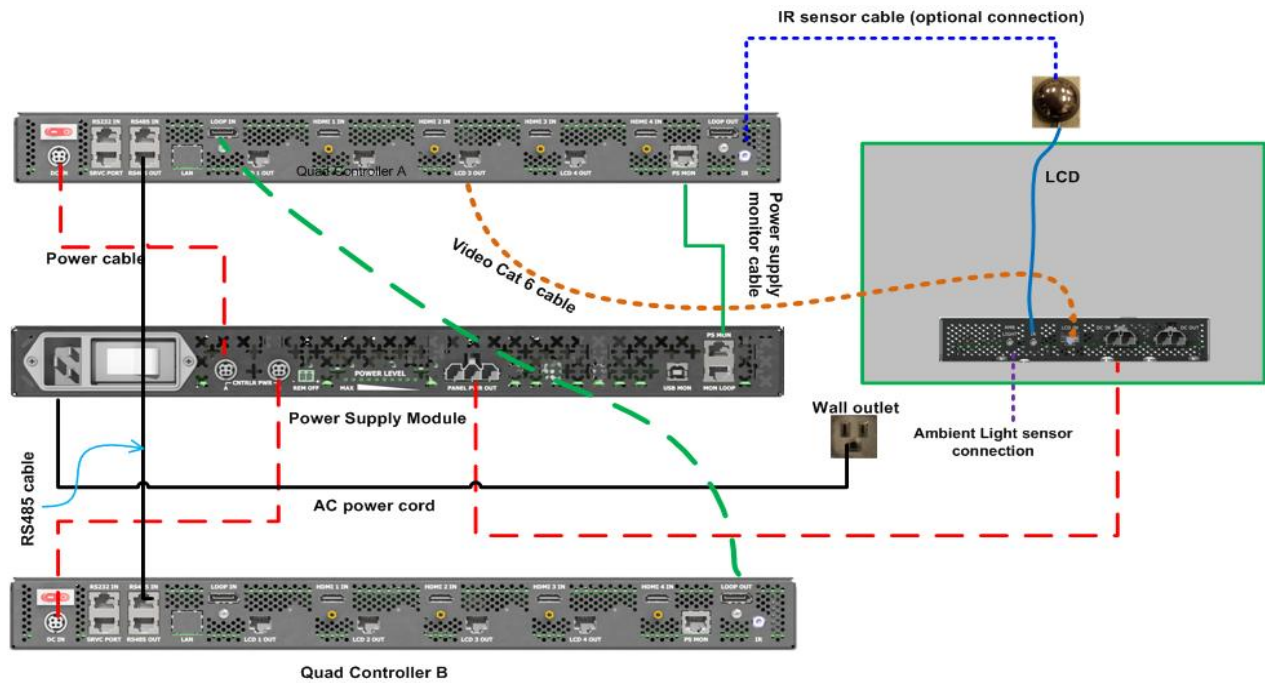

System Addresses

Each Quad controller module contains four microprocessor/scaler engines that each control one LCD. Each microprocessor has an address to which the master uses to communicate with. These are also the addresses that an external host computer will use when controlling the system through RS232. These addresses are determined by the system, not by the installer. Each Quad controller module has a letter address: A through P. This address is set via the address selector dial (see next page for a picture) on the front of the module. You must set this selector so that each Quad controller module in your system has a unique address. Each Quad controller module has four processors, numbered 1 through 4. The address of each processor is the combination of the Quad controller module letter address and the processor number address. For example, A1, A2, A3, A4, B1, B2, B3, B4, etc. Throughout this manual we will be using these addresses to refer to these processors.

Since each processor controls one LCD, we will also be referring to LCDs by this letter/number designation. Keep in mind that if you change where the video cables were connected for a particular LCD, its address will change. **An LCD's address is not determined by its position in the array, rather by its Quad Controller module connection.**

Each Quad controller module also has four HDMI input connections. These four inputs are closely associated with the corresponding LCDs. So in this manual we will also be referring to these connections by letter and number designations, A1, A2, A3, etc. Whether an address refers to an input, a processor, or an LCD will be apparent from the context.

Quad Module A, and specifically processor A1 has special duties. It is referred to in this manual as the master. The IR remote input, the (optional) host RS232 connection and the (optional) network connection are all made on processor A. LCD A1 displays most of the menus.

Setting the Address of Each Quad Controller Module

For each Quad controller module that is connected to LCDs, you will need to set an address (similar to a unit ID) on the front of the Quad controller module. Using the Quad controller module address adjustment tool, manually turn the dial in the middle of the address selector to the letter you want to be identified with the LCDs connected to this Quad controller module. It is important to note that each module must be unique. So one Quad controller module needs to be A, the next B, etc.

Use the address adjustment tool to turn this dial to the letter you want



It is recommended that you set the addresses when the Quad controller modules are turned on. This makes it easier to see LEDs as you switch between addresses. Once you have set the IDs how you want, it is recommended that you power cycle all Quad controller modules.

Connecting Sources

Note: If you do not connect your sources at this time, you can do the Matrix Layout (see "Matrix Layout Menu" on page 70) and color balance (see "Adjusting Color Balance" on page 71) before sources are connected.

The digital inputs of the Clarity Matrix Video Wall give you the flexibility to create a variety of configurations that can be displayed. There are three basic ways that you will most likely use your video wall.

- Spread one picture over the entire video wall.
- Plug in individual inputs into each LCD in the wall.
- Spread one picture over a section of the wall, or what we'll call a sub wall, and have individual inputs on the other displays.

Each Quad controller module has four HDMI inputs, a DisplayPort Loop input and a DisplayPort Loop out. How you connect your sources may depend on what you want to do with the wall. Familiarize yourself with the configuration scenarios ("Understanding Wall Configuration" on page 119) before connecting your sources. If in doubt, connect each source to the HDMI In connector that corresponds to the LCD connector where you want that source to be displayed. If you plan to use any form of the Clarity Big Picture, cable the Loop Out and Loop In connections as shown in "Loop-Through" on page 63. If you want to connect an analog source to the Clarity Matrix Video Wall, you will need to use an analog to HDMI converter or matrix switcher that converts analog signals to HDMI.

Quad Controller Status LEDs

LEDs on the front of the Quad Controller module can indicate a number of different things. The following shows the most common occurrences.

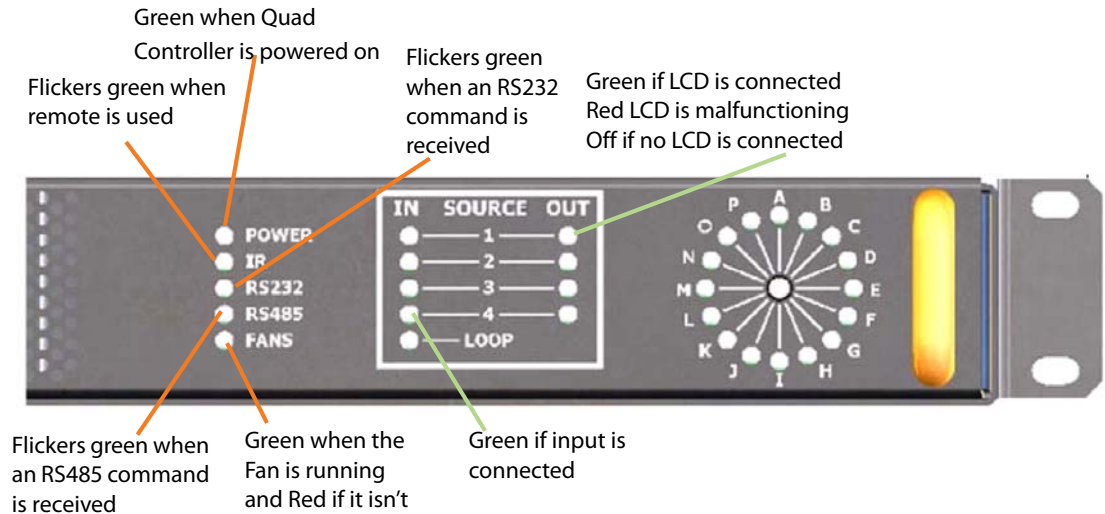

While the Quad Controller module is updating its other three processors, the lights on the front have a distinctive pattern. Every other light in the circle will be illuminated. The Output lights will slowly change from red to green. One of the lights will be red when the other three are green. That is the processor which is currently being programmed. The entire process for all three processors should take about 20 minutes. Do not turn off the power during this time. Wait until all controllers have finished and the front panel lights have returned to normal. Then turn off the power to all modules one more time and power the system on as normal.

Loop-Through

All of the “Quick Configure” settings and many other configurations rely on the system being configured for loop through, as shown in the diagram below. Connect a cable from the LOOP OUT connector of the first Quad controller module to the LOOP IN connector of the next Quad controller module. Connect the LOOP OUT connector of the final Quad controller module to the LOOP IN connector of the first module, completing the loop. Below is an example of a basic loop through.

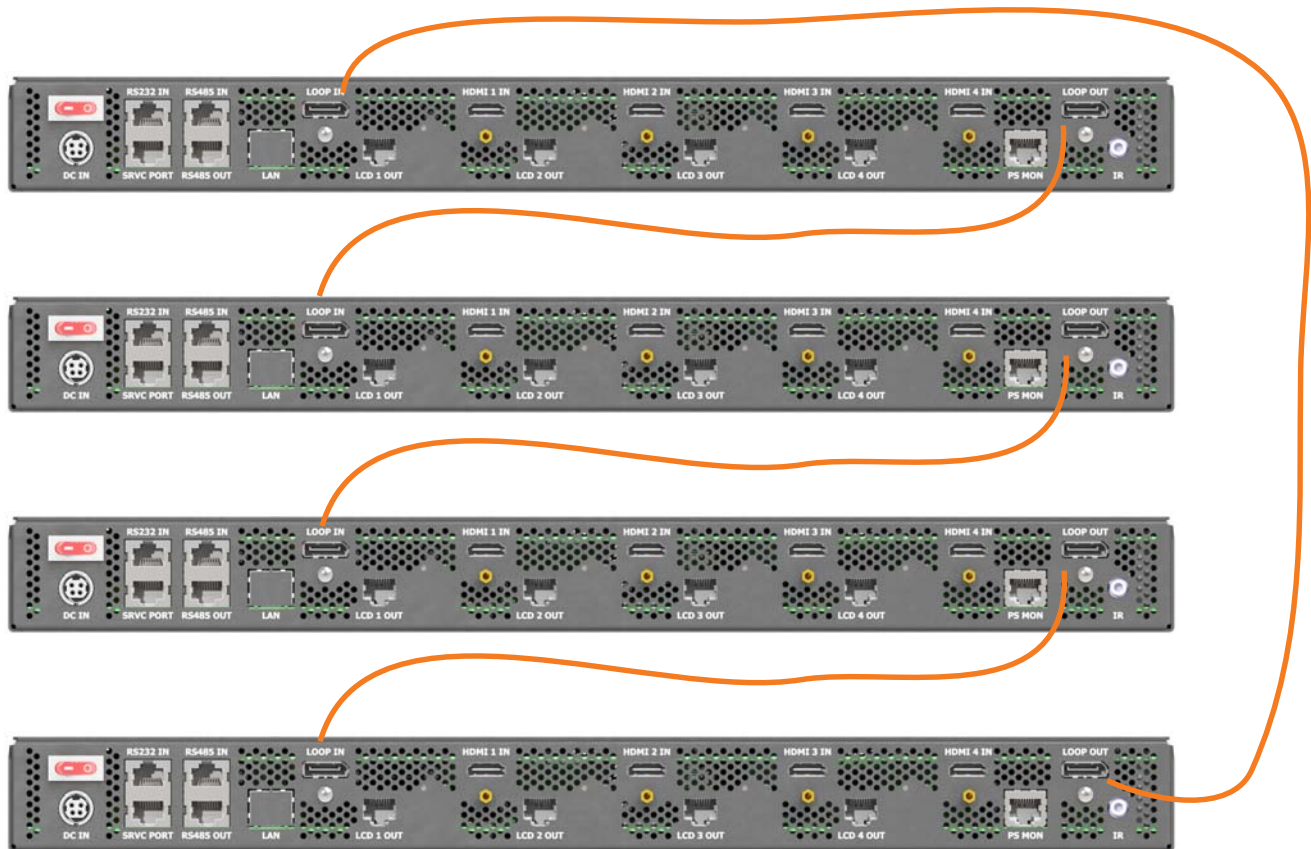

Configuring a Clarity Matrix Video Wall

Menu Settings

There are four different types of menu in the on-screen menus: navigational, global, local and status. These will be described in more detail on the following pages.

Basic Configuration Steps

Configure your displays by performing steps in the following order:

- 1 Matrix Layout (global) - see "Matrix Layout Menu" on page 70.
- 2 Color Balance the displays (local) - see "Adjusting Color Balance" on page 71.
- 3 Configure Wall Settings. See "Understanding Wall Configuration" on page 119 for more information.
- 4 If you need to adjust the on-screen image, see "On-Screen Menus" on page 145 to see different menu options.

Master vs. Slave Displays

The master display is the LCD where the bulk of the on-screen menu configuration and off-board configurations will be controlled. The master display is the one plugged into the LCD 1 connector of Quad controller module A, which is identified on screen as A1. All other displays in the array are considered "slave" displays, which will receive many global software and hardware commands from the master (A1). Information specific to individual displays can be controlled on slave displays.

Menus and the Remote

All on-screen menus are controlled using a specific remote control created for the Clarity Matrix LCD Video Wall System. This remote allows you to access the four menu types: navigational, global, local and status. These menus are described below.

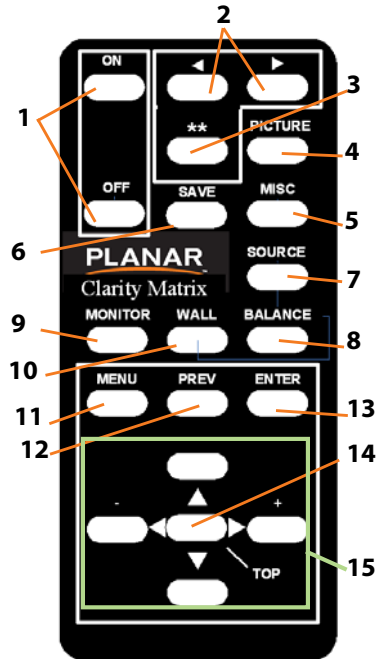

| Number | Definition |
|--------|--|
| 1 | ON/OFF Turn the display ON/OFF. |
| 2 | ◀ ▶ Move the target left or right. |
| 3 | ** Set the target to all at once. |
| 4 | PICTURE With each press, go to Picture, Input Levels, Aspect Ratio, Picture Position, Zoom Top & Left, Zoom Bottom and Right. |
| 5 | MISC With each press go to Miscellaneous submenu, main Miscellaneous Options menu, Backlight Settings and Serial Port Settings. |
| 6 | SAVE Press once for Recall, twice for Save. |
| 7 | SOURCE Takes you to the next Quick Configure setting (Big Picture, A1, A2, etc.) |
| 8 | BALANCE Press once for the Color Balance menu. |
| 9 | MONITOR With each press, go to Unit Status, Serial Port Status, Setup Summary and Test Patterns. |
| 10 | WALL Open the Wall Configuration menu. |
| 11 | MENU Bring up the on-screen menus. |
| 12 | PREV Return to the previous menu. |
| 13 | ENTER Press to select a menu option. |
| 14 | TOP Move the highlight bar to the top line of the menu. |
| 15 | ▼ ▲ ▶ ◀ Arrow keys move the highlight bar around on the menu to select the option you want. |

Note: Keep in mind that you need to point the remote towards where the IR sensor is mounted. Arrows on menu lines lead to other menus:

- Solid black arrows ▶ lead to navigational menus.
- Hollow blue arrows > lead to status menus.
- Hollow green arrows ▷ lead to slave menus.

Navigational Menus

Navigational menus appear only on the master display, which can be identified on screen by A1. These menus simply allow you to get to other menus, and there are no active functions directly available from them.

- Diagnostics
- Picture

Global Menus

Global menus can only be controlled on the master (A1) display. Any changes made to global menus will result in changes to the entire wall. The following menus are globally controlled:

- Backlight Settings
- Factory Settings
- Matrix Layout
- Memory
- Miscellaneous Options
- Quad Module Route
- Serial Port Settings
- Set Clock/Schedule Events
- Wall Configuration

Status Menus

Status menus appear on all displays simultaneously and show information specific to each display. Status menus are informational and no settings can be changed. The following menus are status menus:

- Hours
- Picture Information
- Program Information
- Serial Port Status
- Setup Summary
- Unit Status

Local Menu

Local menus allow you to make changes to a specific display as needed. This allows you to better fine-tune certain settings, such as scaling or overscan. Local menus can appear on any display, either one at a time or all at once. You need to select which display you want to control by using the **target control buttons** on the remote control. The following menus are locally controlled:

- Aspect Ratio
- Big Picture
- Diagnostics
- Input Levels
- Picture
- Picture Position
- Size & Position
- Test Patterns
- Wall Setup
- Viewport Bottom & Right
- Viewport Top & Left
- Zoom Bottom & Right
- Zoom Top & Left

This button puts the local menu onto all displays at once.

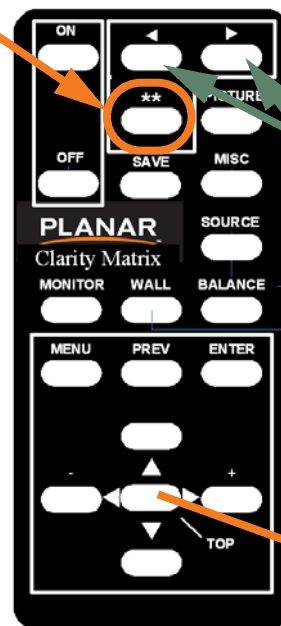

These arrows move the local menu to the next display in the array.

Top button

When displaying local menus on all LCD modules at the same time, the highlight bar might be on a different line on each menu. Use the TOP button to simultaneously move the highlight bar to the same place on all menus.

Display IDs

LCD displays are identified with a letter and a number, called a display ID. The letter is set on the front panel of the Quad controller module (see "Setting the Address of Each Quad Controller Module" on page 61). The number is chosen by the connector to which the display is connected.

If this display will show local menus, the display ID has a green square around it. The master (A1) display has a red square around it.

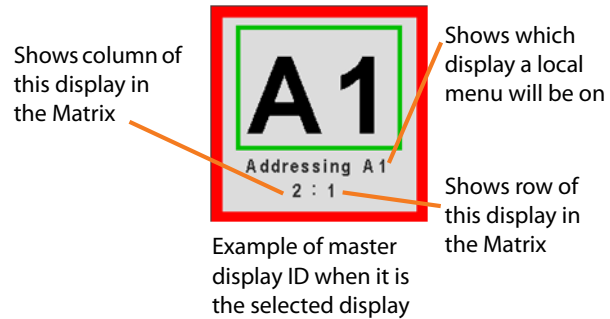

RS232 Communication

RS232 control is not necessary for operation, but is a convenient way to control displays from a computer at a distance. If your installation will not use RS232 control, skip this section.

Everything you can do with the remote, you can do with RS232 commands. Plus, you can send inquiries to the displays and find out the current settings and values.

Connecting RS232 Cables

- 1 Connect the 9-pin adapter to the serial output connector of the controlling computer. (This computer does not have to be the same one as the computer used as a picture source.) The serial output is sometimes called the Comm Port, and sometimes there is more than one.
- 2 Connect a cable from the RJ-45 adapter to the RS232 connector of the Quad controller module A.

For more information about configuring RS232 communications, see "Serial Port Settings and Diagnostics" on page 105.



RS232 port connection is on the Quad Controller module.
Only connect to Quad module **A** or the connection won't work.

Wiring the adapter

To go from 9-pin D-sub serial connector on the back of the computer to an RJ45 connector, use a standard RJ45-to-9-pin adapter. Wire it internally as shown. The wiring shown for this adapter is correct for *straight-through* cables. Straight-through cables are wired 1-to-1, 2-to-2, etc.



| | RJ45 | 9-pin |
|-------------|------|-------|
| Yellow wire | 6 | 3 |
| Black wire | 3 | 2 |
| Green wire | 5 | 5 |

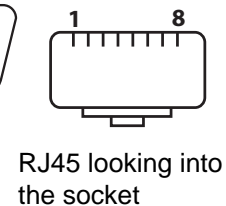
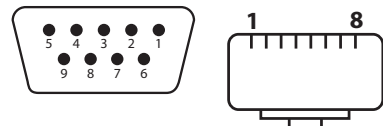

RJ45 looking into the socket

Matrix Layout Menu

The Matrix LCDs are equipped with sensors that allow them to know their position in the array. The master (A1) keeps track of this information and displays it in the MATRIX LAYOUT menu. To start the automatic discovery process, go to the MATRIX LAYOUT MENU (MAIN MENU > WALL CONFIGURATION > MATRIX LAYOUT) and select the AUTO option. The discovery process takes about 5-10 seconds for the entire wall.

Caution: You **must** complete this step before performing any other on-screen menu configurations!

The screenshot shows the 'Matrix Layout' menu with the title 'PLANAR' in the top right. Below the title is the instruction '<Enter> to update matrix layout'. The main area is a grid with columns labeled 'Auto', 'Quick', and 'Reset', and a final column with '**'. The first three rows of the grid are populated with labels: Row 1: A1, A2, A3; Row 2: B1, B2, B3; Row 3: C1, C2, C3. The 'Auto' column header is highlighted in yellow.

| Auto | | | Quick | | | Reset | | ** |
|------|----|----|-------|--|--|-------|--|----|
| A1 | A2 | A3 | | | | | | |
| B1 | B2 | B3 | | | | | | |
| C1 | C2 | C3 | | | | | | |
| | | | | | | | | |
| | | | | | | | | |
| | | | | | | | | |
| | | | | | | | | |
| | | | | | | | | |
| | | | | | | | | |

Note: The first time you open this menu, it will be populated from A1 all the way through P4, no matter how many modules you have.

Depending on how your wall is set up, one of four scenarios could occur:

- Auto Layout Complete - The discovery process completed without errors.
- No Auto Layout has been performed - For more information, see "Troubleshooting" on page 157.
- Error in the Layout - This might appear if an LCD is in service mode. For more information, see "Troubleshooting" on page 157.
- If your array is larger than nine wide or nine high, you will not be able to see the entire layout on this menu. A message will appear that indicates this.

Adjusting Color Balance

Color Balance is used to select the color temperature of each display, as well as to match the colors of adjacent displays when several displays are arranged in an array. When you see a yellow car move across a video array from one display to another, you want it to have the same color for the whole trip, not change from yellow to tan to orange.

Colors vary slightly from one display to the next, because of slight variations in the backlights and displays. This cannot be avoided, but you can compensate for it with color balancing.

Caution: In order to maintain temperature specifications, displays with protective optically bonded glass installed have a lower maximum brightness. Do not attempt to color balance a mixture of displays with and without protective optically bonded glass.

Understanding Color Temperature

Different “pure white” light sources do not always have the same color. For instance, light from an incandescent bulb has more yellow than light from direct sunlight. “Color Temperature” is a way of measuring these color differences. In general, higher color temperature numbers are bluer or “cooler.” You may have a reason for wanting your display to be a specific color temperature. For instance, if you are using the Clarity Matrix Video Wall in a television studio where you will be videotaping the content, you will want a low color temperature. The Clarity Matrix Video Wall defaults to the brightest setting possible, which is 100 in the RED, GREEN and BLUE lines under WHITE BALANCE. You may choose a different color temperature by setting it in the COLOR BALANCE menu.

Adjusting Color Temperature

Select the COLOR TEMPERATURE line in the COLOR BALANCE menu and then select from 3200°K (Warm), 5500°K, 6500°K, 8500°K (Cool) or NATIVE. If you want the brightest display, select the NATIVE option.

Changing the color temperature changes the three WHITE BALANCE values. You can also change the WHITE BALANCE values individually to create a custom color temperature. Once you have changed the values, a new CUSTOM option is available on the COLOR TEMPERATURE line.

Note: Resetting Color Balance: Most displays in a shipment are color balanced at the factory. If this has happened, the Color Balance menu will show a CUSTOM Color Temperature when you first turn them on. If you make color adjustments to a display, you can return to this value with the RESET TO FACTORY. If you want to start with the brightest possible display and do your own color balancing, you can use RESET TO NATIVE.

Color Balancing Multiple Displays

Color balancing is subjective. It may seem strange at first, but it gets easier with practice. Fortunately, you don't have to match all the colors; you only have to match whites and grays. It is not necessary to achieve a perfect white or a perfectly colorless gray. It is only necessary that all the displays look alike when they display white and gray.

Caution: Never try to match the colors of the displays with the black and white level controls or with the video controls.

Caution: If you are color blind, even a little bit, do not color balance your array. Have someone else color balance the wall.

- 1 Turn on all the displays in the array and let them warm up for at least 5 minutes. The backlights must be thoroughly warm before you color balance.
- 2 Press MISC twice on the remote to open the BACKLIGHT CONTROL menu. Set the global backlight level to the desired brightness.



- 3 Open the COLOR BALANCE menu by pressing BALANCE on the remote.

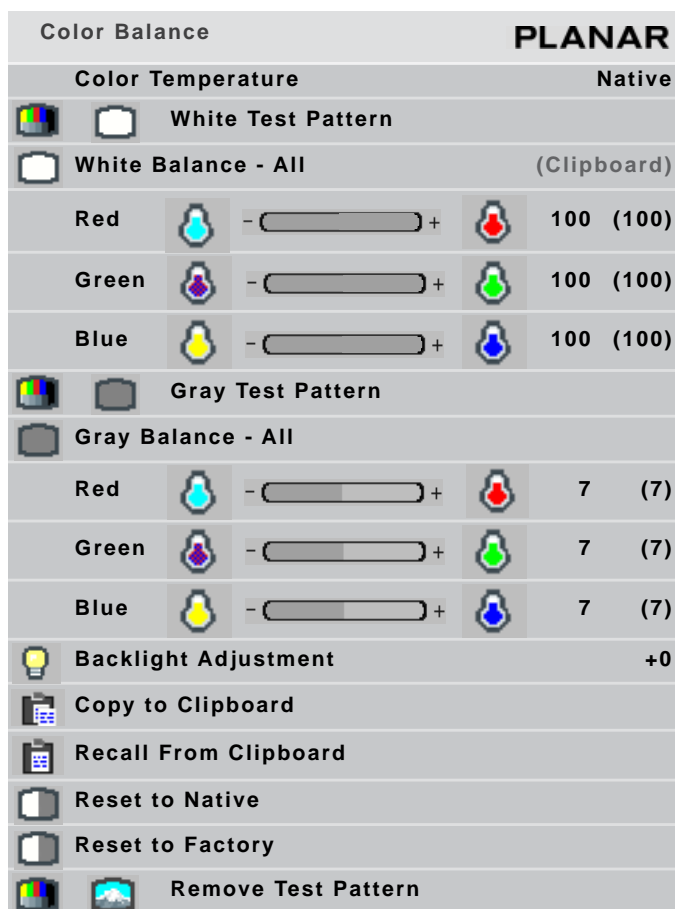

Note: The color balance menu is a local menu. For more information about navigating local menus, see "Local Menus" on page 67.

- 4 Press the ** button to show the menu on all displays.
- 5 If the array has never been color balanced, make sure you start with the same color temperature setting on each display.
 - a If you are not interested in achieving a specific color temperature, use NATIVE, which is the brightest.
 - b If the display has been color balanced before, it will display CUSTOM in the COLOR TEMPERATURE line, because the balance values don't match any of the pre-set color temperatures.
 - c To reset all displays to the factory default setting, select "Reset to Defaults" and press ENTER.
- 6 Highlight the WHITE TEST PATTERN line and press ENTER. This will show the white test pattern on all displays.

Note: Always use the *internal* Test Patterns for color balancing, *not* an external pattern.

- 7 When all displays are white, find the *least bright* display in the array. This will be the “baseline” display, and you will *not* adjust it. All other displays will be adjusted to this baseline display.
Why pick the “least bright” display? Why not pick the brightest and adjust to it? When the white value is 100, the display is as bright as it can get. You are adjusting for slight variations in backlight brightness.
- 8 Choose a display next to the baseline display and adjust its BACKLIGHT ADJUSTMENT to make its overall brightness match the baseline display. (If you can’t bring this setting down to match the baseline, maybe you didn’t choose the darkest display.)
- 9 Continue with other adjacent displays until the overall backlight brightness matches on all displays.

Note: The backlight adjustment does not affect the color of the display.

- 10 Choose a display next to the baseline display and adjust its white values (red, green and blue) to make its color match the baseline display. Concentrate on the center of the displays, not the adjacent edges. Do *not* adjust the gray values at this time.
- 11 Continue with other adjacent displays until all the displays have the same appearance when white.
- 12 When all displays look the same when displaying the White test pattern, highlight the GRAY TEST PATTERN line and press ENTER. This will show the gray pattern on all displays.
- 13 Choose any display as the new baseline display. It does not need to be the baseline display you used for white.
- 14 Adjust the gray values for all the displays until they match the baseline display. Do one display at a time. Again, match the center part of the picture, not the edges.
- 15 When all displays match in gray, highlight the REMOVE TEST PATTERN line and press ENTER. Press MENU to close all the menus.
- 16 If you need to start over, you can always select RESET TO FACTORY or RESET TO NATIVE and press ENTER. (See Resetting Color Balance in the Note on page 71.)

Tips for Color Balancing

Note: A Color Balance Tool is available as a separate kit. It has a sensor and a PC program that will automate the color balance process.

- COPY TO CLIPBOARD will save all the current settings to a temporary memory. You can then make more adjustments to see if it gets better or worse. RECALL FROM CLIPBOARD will restore these saved settings. The clipboard is only for testing. These values are not saved when AC power is off.
- Stand back from the array and directly in front of it to get an overall view.
- Small changes are difficult to see at first, particularly with white. When you don't know which color to change, pick one at random and change it 4 or 5 steps. The result will be either better or worse. If worse, go the other way with that color. If that is also worse, put this color back where you started and do the same with another color. If everything you do makes the match worse, you must be close to the ideal point.
- Removing red has the same effect on hue as increasing blue and green together. The COLOR BALANCE menu slider bars have colored bulbs at each end to tell you what the effect will be of moving a color toward that end.
- Changes in the white values affect the gray values but changes in gray values do not affect the white values.
- Color balance values are saved on the LCD Interface board, so they will be correct for the display even if it is moved to a different Quad Controller output.

In the MISCELLANEOUS OPTIONS menu (MAIN > ADVANCED OPTIONS > MISCELLANEOUS Options) there is a checkbox **Allow 10 Bits Per Color** (default is checked). When this is checked and the source is 10bpc, the display does its converting algorithm and the picture is slightly improved. However, if the source is 1080p, the data is coming to the display too fast for it to handle, and it uses 8bpc, whether or not this box is checked.

| Miscellaneous Options | | PLANAR |
|-------------------------------------|----------------------------|----------------|
| <input checked="" type="checkbox"/> | Menu Timeout | Never Time Out |
| | Rotate Menu | None |
| <input type="checkbox"/> | Hide Source Absent Message | |
| <input checked="" type="checkbox"/> | Allow Frame Lock | |
| <input checked="" type="checkbox"/> | Allow 10 Bits Per Color | |

You can see which color depth is currently used in the Picture Information menu.
(MAIN MENU >PICTURE > PICTURE INFORMATION)

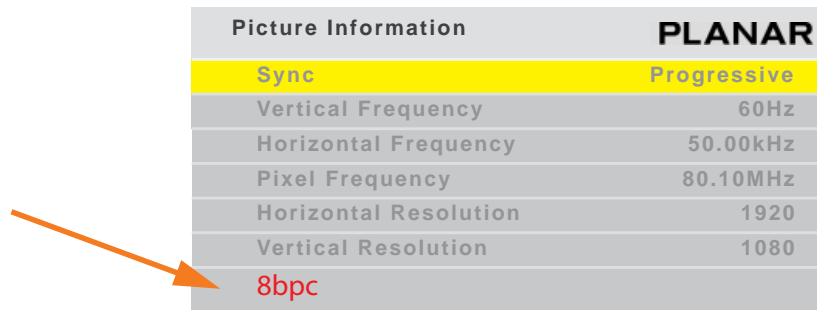

The image shows a screenshot of a 'Picture Information' menu. The menu is displayed in a grey-themed interface. At the top, 'Picture Information' is on the left and 'PLANAR' is on the right. Below this, there are several rows of settings. The 'Sync' row is highlighted in yellow and shows 'Progressive'. Other rows include 'Vertical Frequency' (60Hz), 'Horizontal Frequency' (50.00kHz), 'Pixel Frequency' (80.10MHz), 'Horizontal Resolution' (1920), and 'Vertical Resolution' (1080). The final row shows '8bpc' in red text, with an orange arrow pointing to it from the left.

| Picture Information | PLANAR |
|-----------------------|-------------|
| Sync | Progressive |
| Vertical Frequency | 60Hz |
| Horizontal Frequency | 50.00kHz |
| Pixel Frequency | 80.10MHz |
| Horizontal Resolution | 1920 |
| Vertical Resolution | 1080 |
| | 8bpc |

Advanced Options

Advanced options are used mostly for fine tuning and will rarely need to be used. The most commonly used items in the **ADVANCED OPTIONS** menu are described in the following sections:

- Color Balance: see "Adjusting Color Balance" on page 71
- Backlight Settings: see "Backlight Control" on page 90
- Miscellaneous Options: see "Miscellaneous Options" on page 78

The less commonly used options are covered in the following sections of this manual:

- Size and Position: see "Adjusting Position" on page 104
- Serial Port Settings: see "Serial Port Settings and Diagnostics" on page 105
- Set Clock/Schedule Events: see "Setting the Clock and Scheduling an Event" on page 81

| Main Menu | PLANAR |
|-------------------------|--------|
| Wall Configuration | ▶ |
| Picture | ▶ |
| Memory | ▶ |
| Diagnostics | ▶ |
| Advanced Options | ▶ |
| Program Information | > |

| Advanced Options | PLANAR |
|------------------------------|--------|
| Color Balance | ▷ |
| Size and Position | ▶ |
| Miscellaneous Options | ▶ |
| Backlight Settings | ▶ |
| Serial Port Settings | ▶ |
| Set Clock / Schedule Events | ▶ |
| EDID | ▷ |
| Orbiter | ▶ |

Miscellaneous Options

The MISCELLANEOUS OPTIONS menu contains several unrelated settings. The MISCELLANEOUS “slave” menu is the first menu to appear when you press the MISC button. To access the main MISCELLANEOUS OPTIONS menu, press MISC *twice* on the remote.

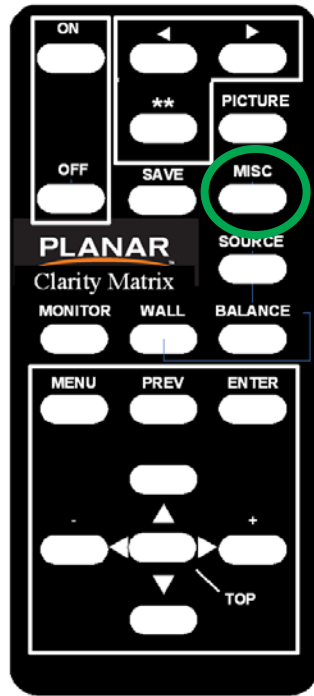

| Miscellaneous Options | PLANAR |
|---|----------------|
| Menu Timeout | Never Time Out |
| Rotate Menu | None |
| <input type="checkbox"/> Hide Source Absent Message | |
| <input checked="" type="checkbox"/> Allow Frame Lock | |
| <input checked="" type="checkbox"/> Allow 10 Bits Per Color | |

Menu Timeout

Determines how long the on-screen menus will be displayed; the range is 0-60 seconds; NEVER TIME OUT means the menus will remain on screen until you choose to turn them off.

Rotate Menu

Makes the menus readable when the display is arranged in portrait or landscape orientation. ROTATE MENU does not rotate the picture. It only arranges the menus so they read the same way the picture does. To use the display in portrait mode, your source image must be rotated.

Hide Source Absent Message

When there is no source, a message box appears on the display saying Source Absent. This message will remain for 30 seconds and then is erased. If the user turns on the menu system, the source absent message appears again for another 30 seconds. Some users would rather not see the source absent message, so this checkbox allows the messages to be turned off completely.

Allow Frame Lock

Frame lock causes the display to synchronize its vertical refresh timing with that of the incoming source. This prevents frame tearing or frame dropping. To frame lock, the incoming signal must be within the refresh parameters of the display itself, which is from 50 Hz to 60 Hz.

Allow 10 Bits Per Color

Matrix G2 displays normally use 10 bits per color unless the bandwidth of the signal is too high. Then it will automatically revert to 8 bits per color. However, there may be signals that cause problems and that the Matrix G2 processor didn't detect, causing it to revert to 8 bits per color. Checking this box should prevent this problem.

Auto Color Space

Digital pixels can be encoded in several ways. The pixel may consist of values for red, green and blue which combine to make up the final color. This is known as RGB color space. Alternatively, the pixels may be encoded with the brightness of the pixel in one value, and the color information on the other two values. This is known as YCbCr encoding.

Normally the values range from 0 to 1023 for 10 bit per color or 0 to 255 for 8 bit per color, but they could be encoded using only 16 to 235 for 8 bit values or 64 to 940 for 10 bit values. This is compressed color and is sometimes used in video (as opposed to computer) signals.

HDMI signals have extra information aside from the video embedded in the signal. This extra information is known as infoframes. Details on the color space are one of the types of data carried in infoframes. The HDMI receiver chips in the Matrix system are capable of decoding infoframes and converting the pixels into RGB full color automatically.

Matrix G2 is capable of converting the pixels to RGB, but it must be told what the incoming signal is; it can't always do it automatically. This makes things complicated in the Matrix G2 system, because the processor which controls the HDMI receiver is not always the same as the one that displays the image.





Color Depth

Color Depth simply means the number of bits used to define each color. Normal color depth is 8 bits per color (8bpc), but some picture sources have 10bpc. Although the Matrix G2 display has 8bpc, it is capable of handling an input with 10bpc with an improved picture. It does this by interpolating and dithering the information in the two least significant bits.

In Matrix G2 there are 4 settings for the colorspace parameter: AUTO, RGB, RGB-VIDEO and YCbCr.

| Main Menu | PLANAR |
|---------------------|--------|
| Wall Configuration | ▶ |
| Picture | ▶ |
| Memory | ▶ |
| Diagnostics | ▶ |
| Advanced Options | ▶ |
| Program Information | > |

| Picture | PLANAR |
|----------------------|--------|
| Picture Information | > |
| Picture Setup | ▷ |
| Aspect Ratio | ▷ |

| Input Levels | PLANAR |
|--|------------------|
|  Colorspace | AUTO |
| Center Point (frame buffer) | 929 832 699 |
| Center Point (processed) | 914 828 622 |
|  Black Level (offset) - All | - [Slider] + |
| Red | - [Slider] + 128 |
| Green | - [Slider] + 128 |
| Blue | - [Slider] + 128 |
|  White Level (gain) -All | - [Slider] + 128 |
| Red | - [Slider] + 128 |
| Green | - [Slider] + 128 |
| Blue | - [Slider] + 128 |
|  Set to Nominal for RGB Levels (0-255) | |
| * Copy Settings to All Displays | |
| *** | |

The default setting is **AUTO** which relies on the HDMI receiver to detect the colorspace and convert it to RGB.

The other settings are used when there is no HDMI information, such as when a DVI-to-HDMI converter is used. **RGB-VIDEO** is used when the incoming signal is compressed color data. In order for the processor to properly convert RGB-VIDEO, it uses an internal block to convert the incoming signal to full range YCbCr and then a second block to convert the YCbCr to RGB. For YCbCr, just the second internal block is used. For RGB no conversions are performed.

Setting the Clock and Scheduling an Event

The Clarity Matrix Video Wall can be easily programmed to schedule specific events, such as turning the display on or off.

- 1 To access the SET CLOCK/SCHEDULE EVENTS menu, press MENU on the remote and from the MAIN MENU, select ADVANCED OPTIONS > SET CLOCK/SCHEDULE EVENTS.

| Main Menu | PLANAR |
|-------------------------|--------|
| Wall Configuration | ▶ |
| Picture | ▶ |
| Memory | ▶ |
| Diagnostics | ▶ |
| Advanced Options | ▶ |
| Program Information | > |

| Advanced Options | PLANAR |
|------------------------------------|--------|
| Color Balance | ▷ |
| Size and Position | ▶ |
| Miscellaneous Options | ▶ |
| Backlight Settings | ▶ |
| Serial Port Settings | ▶ |
| Set Clock / Schedule Events | ▶ |
| EDID | ▷ |
| Orbiter | ▶ |



- 2** Press ENTER to open the EVENT popup menu.
- 3** Do one of the following:
 - To set the clock, see "Setting the Clock" on page 83.
 - To schedule an event, see "Scheduling an Event" on page 83.

Setting the Clock

Use the following instructions to set the clock.

- 1 If 0 is not already selected in the Event # line, use the -/+ keys to select it.

| | |
|-------------------------------|-----------|
| Event # (0= set clock) | 0 |
| Frequency | Never |
| Action | No Action |
| Slot to Recall | 1 |
| Day of Week | Tuesday |
| Year | 2010 |
| Month | 03 |
| Date in Month | 02 |
| Hour | 21 |
| Minute | 30 |

- 2 Depending on the changes you want to make, update any of the following lines:
 - Year
 - Month
 - Date in Month
 - Hour
 - Minute

Note: Time is calculated using a 24-hour clock. For example, if the current time is 9:30 p.m., set the Hour line to 21 and the Minute line to 30.

- 3 When you are finished making the appropriate changes, press ENTER to see the new time at the top of the SET CLOCK / SCHEDULE EVENTS menu.
- 4 Press MENU to close the menu system.

Scheduling an Event

The most important event that can be “scheduled” for the Clarity Matrix Video Wall is to turn it on or off. Scheduling an automatic shut off time for the Clarity Matrix Video Wall helps ensure that Temporary Image Retention does not occur. The following events can be scheduled:

- Turn wall off/on
- Set the clock ahead/back 1 hour
- Recall a memory slot

Use the following instructions to schedule an event.

- 1 Use the -/+ keys to select the “event number” you want to correspond to this event.

- 2 Use the up/down arrows to select the FREQUENCY line. Use the -/+ keys to scroll through the list until you find the selection you want. The following frequencies can be selected:
 - One Time (e.g. to set clock ahead one hour in the spring)
 - Daily (e.g. to turn the display on/off)
 - Weekly

| | |
|------------------------|--------------|
| Event # (0= set clock) | 1 |
| Frequency | Daily |
| Action | No Action |
| Slot to Recall | 1 |
| Day of Week | Wednesday |
| Year | 2010 |
| Month | 02 |
| Date in Month | 24 |
| Hour | 0 |
| Minute | 0 |

Note: If you have set up a one time event, the frequency will show “Never” once the event has occurred. You can schedule the event to occur again by changing the frequency back to “One Time” and then correcting the date and time.

- 3 Use the up/down arrows to select the ACTION line. Use the -/+ keys to scroll through the list of Action items until you find the one you want. The following actions can be selected:
 - Turn Wall Off
 - Turn Wall On
 - Recall Slot
 - Set Clock Ahead 1 Hour
 - Set Clock Back 1 Hour
- 4 Do one of the following:
 - If you selected “Recall Slot” in the previous step and want to recall a memory slot other than the one shown, go to step 5.
 - If you did **not** select “Recall Slot” in the previous step, go to step 6.

- 5 Use the up/down arrows to select the SLOT TO RECALL line. Use the -/+ keys to scroll through the list until you find the selection you want.

| | |
|------------------------|-------------|
| Event # (0= set clock) | 3 |
| Frequency | Weekly |
| Action | Recall Slot |
| Slot to Recall | 4 |
| Day of Week | Monday |
| Year | 2010 |
| Month | 05 |
| Date in Month | 03 |
| Hour | 12 |
| Minute | 30 |

Note: If you select a memory slot that has not been set up, no action will occur.

- 6 Depending on the frequency you selected and the change you want to make, update any of the following lines:
 - Day of Week
 - Year
 - Month
 - Date in Month
 - Hour
 - Minute

Note: Time is calculated using a 24-hour clock. For example, if you want your wall to turn off at 9:30 p.m., set the HOUR line to 21 and the MINUTE line to 30.

- 7 Continue setting up events until you are finished. Changes are automatically saved each time you move from line to line.
- 8 When you are finished making the appropriate changes, press ENTER to see the new events on the SET CLOCK / SCHEDULE EVENTS menu.
- 9 Press MENU to close the menu system.

Aspect Ratio Settings

The aspect ratio of any picture is its width divided by its height. $W/H = \text{Aspect Ratio}$

The native aspect ratio of the Clarity Matrix Video displays is 1.77. This is sometimes referred to as 16:9 for 1.77. The native resolution of most Clarity Matrix Video displays is 1920 x 1080. The LX46S-3D is an exception with a resolution of 1366 x 768.

Many pictures do not have this aspect ratio. Standard television, VGA, SVGA, and XGA signals are 1.33. Movies from DVDs vary depending on the original film format, but are often 1.85. The larger the number, the “wider” the picture seems.

When the incoming picture is a different aspect ratio from the screen, the display gives you six choices (see SCALE MODE submenu options) to make it fit.

Scale Mode Settings

- 1 To select the Scale Mode, press PICTURE on the remote three times.

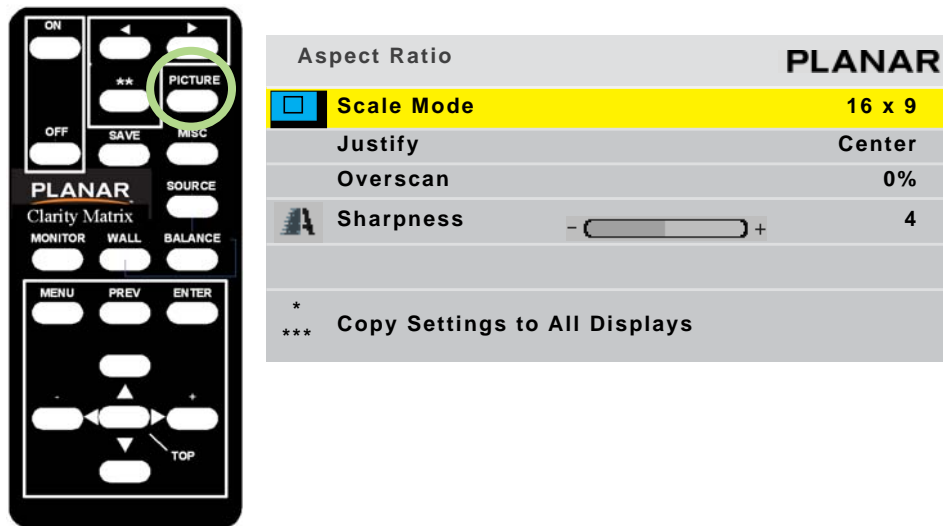

- 2 With SCALE MODE highlighted, press ENTER. The SCALE MODE submenu displays.

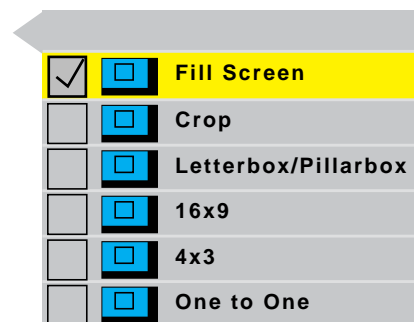

The scale modes are “radio” buttons; you can only choose one at a time.

Note: The display is not capable of compressing the image in one direction while stretching it in the other. For example, if you try to display a UXGA (1600 x 1200) on an Clarity Matrix Video Wall in a 1 x 2 column arrangement (1920 x 1080) at Fill All, the display will letterbox the image and the following note will appear at the bottom of the menu: "Can't display Change Scale Mode." You can leave the scale mode at Fill All or change it to Letterbox. You can also select Crop or One to One.

Note: The SCALE MODE menu icons change to indicate the effect each mode will have on the picture based on the JUSTIFY and SCALE MODE settings, and the source resolution.

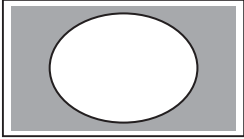
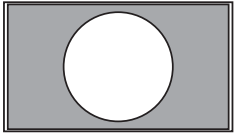
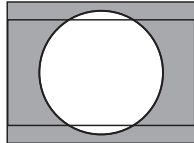
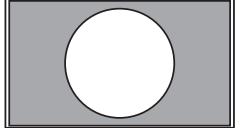
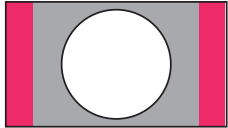
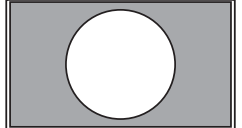
| Scale Mode | Affect on Input Type on 16 x 9 Display | |
|---|--|---|
| | 4 x 3 source (e.g. Standard Video or VGA/SVGA/XGA) | 16 x 9 source (e.g. 1080i or WXGA computer source) |
| Fill Screen | Stretches width of image  | Displays full image without distortion  |
| <p>Fill Screen makes the picture fit top-to-bottom and left-to-right, regardless of how this stretches or compresses the picture. Fill All distorts the picture, when the aspect ratio of the incoming picture is not the same as the display.</p> | | |
| Crop | Crops top and bottom of image; fits width of image without distortion  | Displays full image without distortion  |
| <p>Crop expands non-native aspect ratio pictures until the <i>second</i> edges touch the border and lets the other edges of the picture fall outside the display and get cropped.</p> | | |
| Letterbox /Pillarbox | Fits height of image without distortion; fills width with border  | Displays full image without distortion  |
| <p>Letterbox/Pillarbox expands the picture until the first edges (top-bottom or left-right) touch the border of the display, and then fills in the other sides with a solid color.</p> | | |

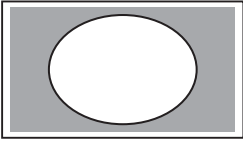
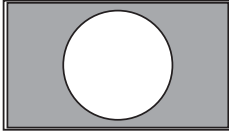
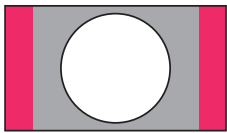
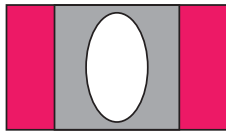
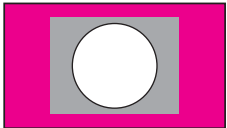
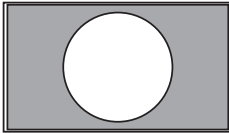
| Scale Mode | Affect on Input Type on 16 x 9 Display | |
|--|---|--|
| | 4 x 3 source (e.g. Standard Video or VGA/SVGA/XGA) | 16 x 9 source (e.g. 1080i or WXGA computer source) |
| 16 x 9 | Stretches image to fill width without affecting height  | Displays full image without distortion  |
| <p>(16 x 9) forces the aspect ratio to 16 x 9 (1.77), the standard for many DVD movies. This will distort any picture other than 16 x 9 aspect ratio pictures. 16 x 9 can be used to display anamorphic DVDs on an array.</p> | | |
| 4 x 3 | Fits height and width of image without distortion; fills width with border  | Fits height of image, compresses width and fills with border  |
| <p>(4 x 3) forces a 4 x 3 (1.33) aspect ratio, the ratio of standard television.</p> | | |
| One to One | Displays image without distortion at actual size  Example above represents a VGA input displayed on one LCD module | Displays full image without distortion  Example above is for 1366 x 768 input displayed on one LCD module |
| <p>One to One maintains the original size and aspect ratio of the picture. This may leave blank areas on all four sides. For instance, a VGA picture (640 x 480) on a 16 x 9 display will occupy only a small area in the center of the screen. The primary use of One to One is to display the image without scaling artifacts.</p> <p>The One to One Scale Mode will produce different cropping results and the image size will be different for each input resolution.</p> | | |

Justify Settings

Justify determines how the picture will be placed in a wall of displays. For a single display, Justify determines placement on the screen. For a wall of displays, if the image is not large enough to fill all the displays in the wall, some will be left blank.

Top/Left

Positions the image starting with the top, leftmost display, then across and down.

Center

Positions the image starting with the center of the image in the center of the wall spreading out equally to all displays.

Bottom/Right

Positions the image starting with the bottom, rightmost display, then across and up.

Overscan

This is used to hide blank areas and stray lines in the edges of an image. The lower the overscan setting, the more of the optical image that is seen. Standard CRT televisions have an overscan of about 5%, which may actually hide content or images that you want to see.

Sharpness

Sharpness settings determine how crisp the image should be. There are sixteen levels of sharpness, where 0 is the softest and 15 is the sharpest. Seven is the default.

Backlight Control

The backlight is optimized for the LCD operation. For normal operating conditions, the backlight can be adjusted for maximum brightness if desired. If you are operating at higher altitudes up to 2000 meters, it is recommended that you run the backlight at a reduced intensity. Running at maximum intensity at high altitudes can affect the lifetime expectancy.

Note: To extend the backlight life, it is recommended that you use the lowest backlight brightness that works for your application. This will reduce power consumption, heat output and reduce the chances of TIR from occurring. (See "What is Temporary Image Retention?" on page 5.)

To open the BACKLIGHT CONTROL menu, press MISC *twice* on the remote.



Note: The last two lines above will only appear on the master (A1) display.

When BACKLIGHT CONTROL MODE is **Manual**, you see the menu above.

When BACKLIGHT CONTROL MODE is **Auto**, you see the menu below

Note: Auto Backlight On only works when an Ambient Light sensor is plugged into LCD A1.



Auto Backlight On

If AUTO BACKLIGHT ON is checked, the display turns on the backlights soon after AC power is applied. It won't wait for a remote control or RS232 command.

This is the normal mode for applications where the displays will be on 24 hours a day. This way, no one has to manually turn on the backlights after a power failure.

Caution: To prevent temporary image retention (TIR), it is recommended that you do **not** leave the Clarity Matrix Video Wall on for 24 hours a day. To get the most out of your display, see "Recommended Usage" on page 5.

If the displays normally have the backlights off for part of the day or night, do not check this box. Otherwise a power failure at night would turn on the backlights.

Turn Backlight Off With No Source and (DPMS) Delay

When checked, TURN BACKLIGHT OFF WITH NO SOURCE (DPMS) causes the backlights to turn off after the source goes absent for the length of time specified in the DPMS DELAY line. If this line is not checked, the backlights remain on indefinitely. To specify an amount of time after which the source is absent that the backlights will shut off, enter that number in the DPMS DELAY line.

Backlight Intensity

The backlight intensity can range from 0-100 in increments of 10. If you are operating at higher altitudes up to 2000 meters, it is recommended that you run the backlight at a reduced intensity.

Dimmed Intensity (Backlight Control Mode is AUTO only)

This sets the intensity of the backlight when the ambient light is below the threshold. Set this value to an acceptable brightness when the room may be at its darkest. This will reduce the power required for panels and the image will be more comfortable for viewers.

Ambient Threshold

This value determines the ambient light intensity required to switch the backlight between Backlight Intensity and Dimmed Intensity. A greater value keeps the brightness at the set Backlight Intensity while a lower value sets the brightness to the Dimmed Intensity. The backlight change will occur when the Ambient Light is five points different from the Ambient Threshold for greater than three minutes. This value is to be determined through observation of the environment as to what is appropriate for the end user. The measured Ambient Light on the OSD will give the value to set the Dimmed Intensity to once conditions have been determined as appropriate. Range is 0 to 255.

Ambient Light Sensor Software Setup

Follow these instructions to make sure the system will work properly.

- 1** Set Backlight Control Mode to AUTO.
- 2** Adjust the Dimmed intensity value to your desired setting. This can be determined by mimicking the dim conditions and determining the proper Backlight Intensity under 'Manual' mode.
- 3** Adjust the Ambient Threshold to the desired value. This can be determined by using the Ambient Light reading from the sensor when the dim conditions were mimicked.
- 4** Set Backlight Control Mode to MANUAL.
- 5** Set Backlight Intensity to desired value under bright operating conditions.
- 6** Reset the Backlight Control Mode to 'Auto'. The system will now change the intensity automatically based on the values provided. If you wish to change these values, do this procedure from the beginning.

Controlling EDID Behavior

EDID (Extended Display Identification Data) is the standard protocol for a display to communicate to a picture source what kind of display it is, what its capabilities are.

Planar displays present to the picture source a default EDID that is not always optimum for the task. Sometimes you will want to control this directly to get best performance. Examples:

- You may use the **Preferred Timing** field in the EDID even though your desired resolution exists elsewhere in the EDID list.
- You may need a non-standard resolution to accomplish mullion compensation without scaling the image.
- The display is configured in a Big Picture Array, and you would like to output one-to-one pixels. The standard EDID can't accommodate all possible Big Picture combinations.
- You are in a country with 50Hz power and would like the EDID timing to be 50Hz rather than the default 60Hz.

You can specify detailed timing for EDID by setting the horizontal active, vertical active, and vertical refresh rate. The system will then calculate the rest of the parameters by using the CVT reduced blanking formula. You can also specify all the timing parameters manually.

All this can be done in the EDID menu. Open the on-screen menu and from the MAIN MENU select ADVANCED OPTIONS > EDID.

| | |
|--|---------------|
| EDID | PLANAR |
| EDID Detailed Timing 1 (Preferred Timing) | ▶ |
| EDID Detailed Timing 2 | ▶ |
| <input type="checkbox"/> EDID Has Only Preferred Timing | ← |
| <input checked="" type="checkbox"/> EDID (Plug and Play) Enabled | |

- If the **EDID Has Only Preferred Timing** is checked, the only timing information in the EDID will be that of the Preferred Timing field. All other timing descriptions in the EDID will be blanked out. This can be useful for some video drivers that always attempt to use the highest resolution in the EDID, even if that isn't the desired behavior.

| | |
|---|---------------|
| EDID Detailed Timing 1 | PLANAR |
| Number of pixels per line | |
| Update EDID | |
| Horizontal Active | 1920 |
| Vertical Active | 1080 |
| Vertical Refresh Rate | 60Hz |
| <input type="checkbox"/> Fully Specified | |
| Pixel Clock | 148.50MHz |
| Horizontal Blanking | 280 |
| Horizontal Front Porch | 88 |
| Horizontal Sync Width | 45 |
| Vertical Blanking | 45 |
| Vertical Front Porch | 4 |
| Vertical Sync Width | 5 |
| Revert to Factory | |

- **EDID (Plug and Play Enabled)** is normally checked. When it is *not* checked, the EDID will be written over with invalid checksums and will appear as an invalid display to the picture source device. This is sometimes useful for troubleshooting.
- **Update EDID** writes all changes made in the **EDID Detailed Timing** menu into the EDID. Writing to the EDID is a slow process, so it is done in the background. **Update EDID** is grayed out unless there are pending changes. When the writing is finished, any attached sources re-read the EDID.
- The same EDID is written to all 5 HDMI sources.
- The **Fully Specified** checkbox determines whether the detailed timing will be calculated from
 - horizontal active, vertical active, and vertical refresh rate (unchecked),
 - or if all fields are specified by the user (checked).

Orbiter Control

For still images that might remain on the display for a long time, the Orbiter lets you move the image slowly to reduce the possibility of temporary image retention.

Spreading Images Across the Wall

For the Clarity Matrix Video Wall, you will need to set up a variety of options that relate to how each display fits into the wall. Whether you use Planar's Big Picture™ or an external video processor, your goal is to make the picture fit together properly at the edges.

Using an External Video Processor

The processor divides a single picture into several sections and sends each part on a separate cable. Connect these cables to the proper display.

You can still position the picture with the display controls. With most processors, you can position and zoom the picture with the processor controls.

Using the Quick Configure Feature

The Clarity Matrix Video Wall contains sensors that easily configure the layout of your wall. Quick Configure sets up the routing (see "Understanding Wall Configuration" on page 119) and the Big Picture Setup (see below) automatically. If you have a more complicated setup and want to manually configure your wall, use the BIG PICTURE SETUP menu.

Using the Matrix Layout

This feature is described earlier in the manual. For more information, see "Matrix Layout Menu" on page 70.

Using Planar's Big Picture™

To use Planar's Big Picture™, you must set the values in the BIG PICTURE SETUP menu for the same wall size on all the LCDs in the wall using the Big Picture feature.

| Wall Configuration | PLANAR |
|--------------------------------|---------------|
| Quick Configure Big Picture A3 | Big Picture ▶ |
| Big Picture Setup | ▷ |
| Matrix Layout | ▶ |
| Quad Module A Route | ▶ |
| Quad Module B Route | ▶ |
| Quad Module C Route | ▶ |
| Synchronize High Resolutions | |

| Big Picture Setup | PLANAR |
|---|-------------------------------|
| Matrix Position | 3x3 1:1 |
| Wall Width | 3 |
| Wall Height | 3 |
| Unit Column | 1 |
| Unit Row | 1 |
| <input type="checkbox"/> Wall Mode | |
| <input type="checkbox"/> Frame Compensation | |
| ⬆ Frame Height | 10 pixels |
| ⬆ Frame Width | 10 pixels |
| * *** | Copy Settings to All Displays |
| | No Big Picture Key installed |

Matrix Position

Shows the current size of the wall and the position of the currently selected panel.

Wall Width and Wall Height

These show the number of displays wide and high for the *picture*. This may be different from the physical size of the wall. You could build a 4 x 3 array of displays and use WALL MODE to put a single picture on the four displays in the upper left corner, for instance. Using the QUICK CONFIGURE line on the WALL CONFIGURATION menu will set these automatically.

Unit Column and Unit Row

These represent the position of the display in this “array.” For example, in the 4 x 4 landscape array of displays shown below, Unit numbering starts at the top left corner of the array. This display would have a Unit Column value of 1 and a Unit Row value of 1. Using the QUICK CONFIGURE line on the WALL CONFIGURATION menu will set these automatically.

| | | | |
|-----------------------------|-----------------------------|-----------------------------|-----------------------------|
| Unit Row 1 Unit Column 1 | Unit Row 1 Unit Column 2 | Unit Row 1 Unit Column 3 | Unit Row 1 Unit Column 4 |
| Unit Row 2 Unit Column 1 | Unit Row 2 Unit Column 2 | Unit Row 2 Unit Column 3 | Unit Row 2 Unit Column 4 |
| Unit Row 3 Unit Column 1 | Unit Row 3 Unit Column 2 | Unit Row 3 Unit Column 3 | Unit Row 3 Unit Column 4 |
| Unit Row 4 Unit Column 1 | Unit Row 4 Unit Column 2 | Unit Row 4 Unit Column 3 | Unit Row 4 Unit Column 4 |

Wall Mode

When checked, this turns on the Planar’s Big Picture™ feature. When not checked, the display shows the whole picture. Using the QUICK CONFIGURE line on the WALL CONFIGURATION menu will set these automatically.

Frame Compensation

When video displays are used in an array, the intent is to display a large version of an image. However, even the thinnest of mullions can break up the image oddly. Notice the eagle's eye here.

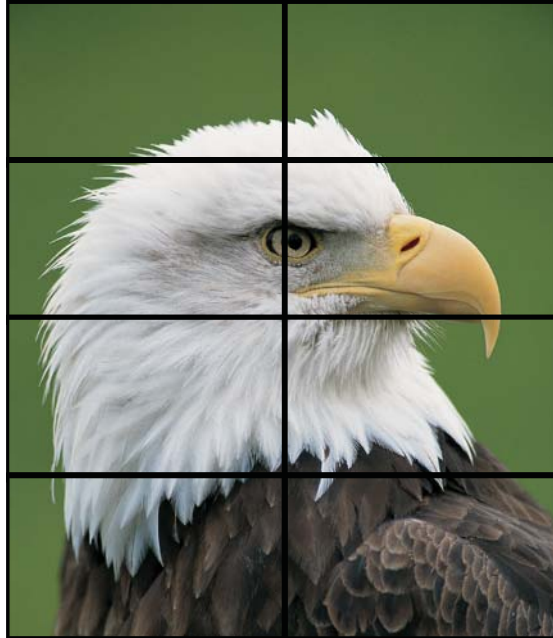

One way around this is to adjust the image. Imagine looking out a window made up of many panes of glass. The image you see is partially obscured by the frames, but your mind assembles the image and ignores the frames.

Note: Frame Compensation is also known as mullion or bezel compensation.

Frame compensation allows you to mimic the mind's function by "hiding" portions of the picture (as if the mullions were actually hiding the image) and allow the distributed image to appear as one very large image.

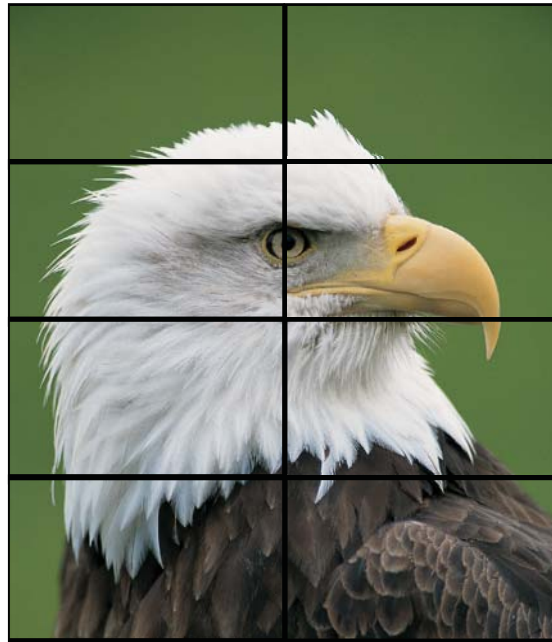

To ensure images containing diagonal lines remain correctly diagonal, turn on Frame Compensation.

Depending on how closely you space the displays, you must determine how much of the picture to "hide" behind the display's mullions and the space between displays.

Frame Height and Frame Width

Frame Height can be set to hide pixels at the top and bottom of images. Frame Width can be set to hide pixels to the left and right of images. The Frame Height and Frame Width numbers default to the correct numbers for your display, assuming they are tiled with the frames tightly together. If your installation leaves more space between the frames, you will need to increase these numbers.

Zoom and Viewport

Zoom fits the edges of a large picture - one that covers many displays' screens - from side to side and top to bottom.

To access the Zoom menus, select MAIN MENU > ADVANCED OPTIONS > SIZE AND POSITION. Then select the ZOOM TOP & LEFT menu or the ZOOM BOTTOM & RIGHT menu.

You can zoom the sides up to +100 pixels *larger* in each direction. You can also zoom the sides up to -100 pixels *smaller*, but only if that side is not the edge of the overall picture.

Zoom Menu Entries

Image Resolution

Shows the resolution of the source picture.

This Unit

Shows the number of pixels this display is using of all the incoming pixels.

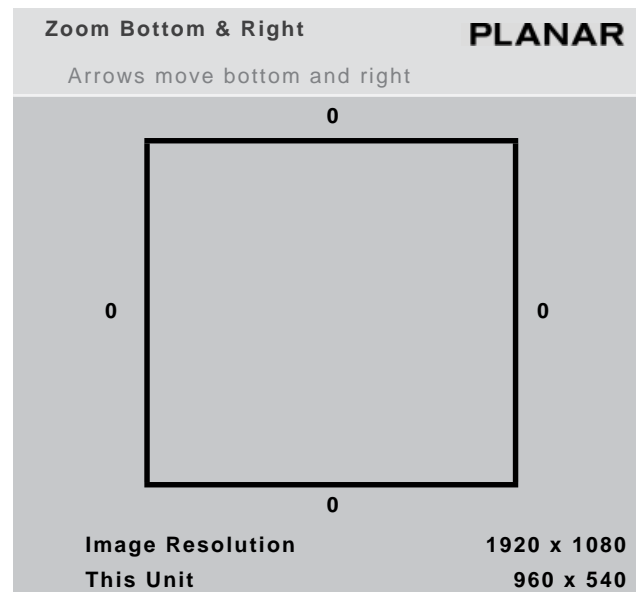
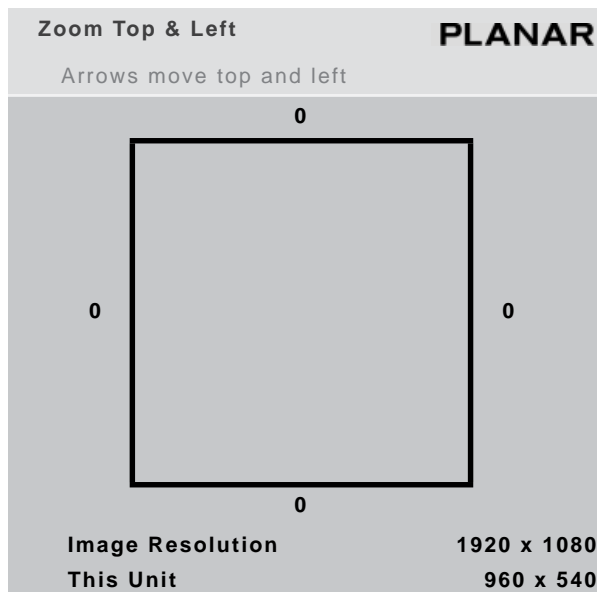

Viewport Adjustment

Use the VIEWPORT menu (MAIN MENU > ADVANCED OPTIONS > SIZE AND POSITION > VIEWPORT WINDOW) to adjust the number of pixels actually used on the display. You can't increase this number, but you can reduce it.

| Main Menu | PLANAR |
|-------------------------|----------|
| Wall Configuration | ▶ |
| Picture | ▶ |
| Memory | ▶ |
| Diagnostics | ▶ |
| Advanced Options | ▶ |
| Program Information | > |

| Advanced Options | PLANAR |
|-----------------------------|----------|
| Color Balance | ▷ |
| Size and Position | ▶ |
| Miscellaneous Options | ▶ |
| Backlight Settings | ▶ |
| Serial Port Settings | ▶ |
| Set Clock / Schedule Events | ▶ |
| EDID | ▷ |
| Orbiter | ▶ |

| Size & Position | PLANAR |
|---------------------------------------|--------------------------------------|
| Picture Position | ▷ |
| Zoom Window Top & Left | ▷ |
| Zoom Window Bottom & Right | ▷ |
| Viewport Window Top & Left | ▷ |
| Viewport Window Bottom & Right | ▷ |
| Reset All Windows to Default | |
| * *** | Copy Settings to All Displays |

Note: The COPY SETTINGS TO ALL DISPLAYS line will only appear if this menu is on the master display (A1).

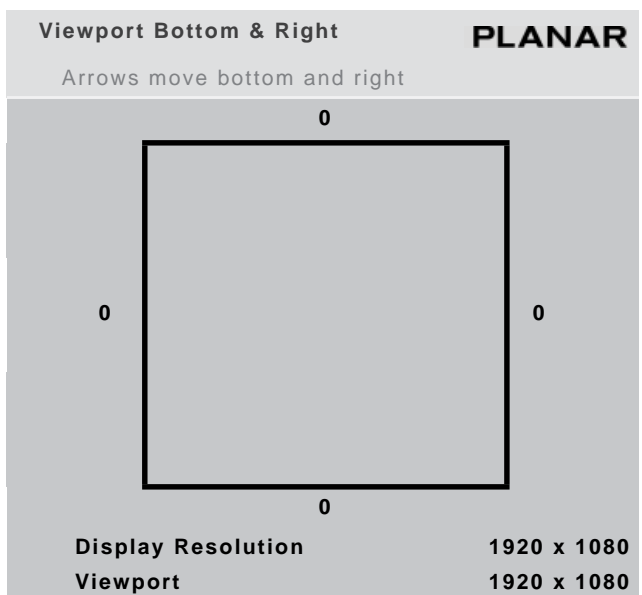
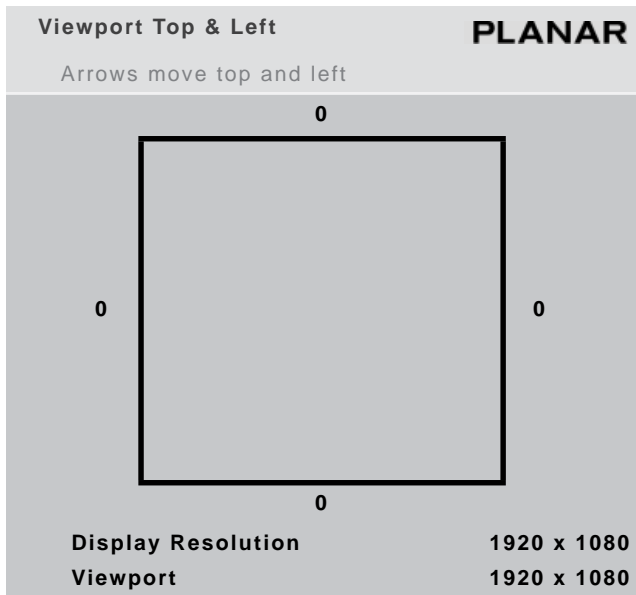

Display Resolution

Shows the resolution of the display. This has nothing to do with the resolution of the source picture.

Viewport

Shows the number of display pixels being used.

Adjusting Position

Position moves the picture on the screen but does not move the menus. Open the PICTURE POSITION menu (MAIN MENU > ADVANCED OPTIONS > SIZE AND POSITION > PICTURE POSITION). The four arrow keys move the picture on the screen.

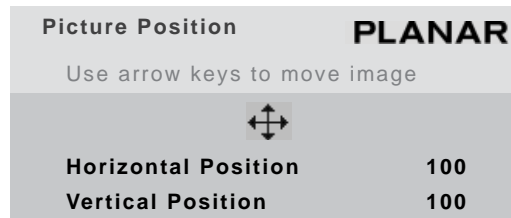

The numbers for Horizontal Position and Vertical Position are arbitrary, where 100 100 is a neutral position. Moving the picture position is equivalent to using both the zoom and viewport adjustments together in order to pan the image. Pixels will be dropped from the image on one side and black space will fill in for the dropped pixels on the other side.

Serial Port Settings and Diagnostics

If you want to control the displays remotely with RS232 commands from a computer, read this section. For more information, see "RS232 Communication" on page 69. RS232 is also used to upgrade the firmware of the Quad controller modules.

Diagnostic information is available from the UNIT STATUS and HOURS menus. For more information, see "Diagnostics" on page 107.

Serial Port Settings

To access the SERIAL PORT SETTINGS menu, select the MAIN MENU > ADVANCED OPTIONS > SERIAL PORT SETTINGS.

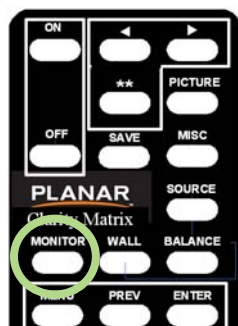

| | |
|----------------------------------|---------------|
| Serial Port Settings | PLANAR |
| ASCII Response Type | Symbolic |
| ASCII Response Terminator | CR |
| Baud Rate | 19200 |

ASCII Response Type

Determines what type of data will be returned to the computer. For human-readable text in a serial program, choose SYMBOLIC. For computer-read data, use NUMERIC or DATA ONLY.

ASCII Response Terminator

Will be determined by what your serial program wants to see at the end of every transmission from the display.

Baud Rate

The baud rate *must* be the same as that used by the controlling computer. The baud rate is *not* automatically set, as it is with modem communications. It must be manually set here **and** at the computer to match each other.

Note: For firmware upgrades, you don't need to adjust the baud rate.

Serial Port Status

The SERIAL PORT STATUS menu provides diagnostic information for the serial port.

To access the SERIAL PORT STATUS menu, press MONITOR *twice* on the remote. You will see the status of the serial port that has had the most recent activity. To view the status on a different serial port, use the arrow key.

To clear the counters back to 0, press <ENTER> on the remote.

| | | |
|---|--|----------------------|
| Serial Port Status RS232 ▶ | | PLANAR |
| <ENTER> to clear; +/- to select different serial port | | |
| Commands Received | | 34 |
| Replies Sent | | 34 |
| Last Packet Type | | Operation |
| Last Packet Address | | Not Addressed |
| Bytes Received | | 921 |
| Bytes Sent | | 773 |
| UART Framing Errors | | 4 |
| UART Overflow Errors | | 0 |
| Group A Unit: 1 | | 19200 Baud |
| Most Recent | | |
| ...115, 111, 108, 117, 105, 111, 110, 63, 13 | | |
| .st--1?.st--2?.st--3?.lcd.vertical-resolution?. | | |

Controlling With RS232 Commands

The RS232 protocol - the "rules" for controlling displays with RS232 commands - are described in a separate document. See "Planar's Technical Support Website" on page 237 to see how to get to the web page. Then look for Clarity Matrix Video Wall and under that the *RS232 Guide*.

Diagnostics

Most of the submenus available from the DIAGNOSTICS menu are not used on a regular basis. Examples of these menus can be found in "On-Screen Menus" on page 145.

To check status information for the system or to see usage information, use the UNIT STATUS and HOURS menus, which are explained in the following sections.

Checking Unit Status

The UNIT STATUS menu shows information for the LCD, Quad controller module and the power supply module. This can be a helpful troubleshooting tool if you are having operational issues with one of the system components.

| Unit Status A1 | | PLANAR | |
|--------------------|--------|-------------|----|
| Matrix 010-1409 | Rev 01 | 1920 x 1080 | |
| LCD | | | |
| Temperature | 20 °C | Backlight | OK |
| 24v Supply | 24.40v | | |
| 48v Supply | 47.31v | | |
| Power | 52.26w | MX46HDS | |
| Quad Module | | | |
| Temperature | 31 °C | Fan | OK |
| Power Supplies | | | |
| | | Fan | OK |
| | | PS | OK |

Note: The QUAD MODULE line only appears on processor number 1 of each Quad controller module. The Power Supply line only appears on processor A1.

LCD

Temperature indicates the current internal temperature inside the LCD module. This is not the ambient temperature nor the temperature to be used to determine if the display is out of specification.

Backlight indicates whether the backlight is operating normally or not.

24V Supply indicates the backlight voltage. If the number is below 22V, there is an issue with the power to the LCD. The likely cause is excessive cable length or cable quality between the power supply module and the LCD module.

48V Supply indicates the incoming voltage to the interface board.

Power indicates the amount of power currently consumed by the LCD module. The display type is also shown.

Quad Module

Temperature indicates the current internal temperature of the Quad module. This is not the ambient temperature nor the temperature to be used to determine if the module is out of specification.

Fan indicates whether or not one or both of the internal module fans are functioning properly.

Power Supply

Fan indicates whether or not a fan internal to the module is functioning properly.

PS indicates whether or not a power supply is functioning properly within the module.

Note: In order for this menu to show power supply module information correctly, the PS MON cable must be plugged in. If it is not plugged in, you will see the message "PS MON CABLE IS NOT CONNECTED."

Checking System Usage

The HOURS menu shows the hours the system and backlights have been in use. It also shows the average LCD usage information.

| Hours | PLANAR |
|---------------------------|----------|
| System Time | 00636:45 |
| Backlight Time | 00532:00 |
| Average Hours Per Day | 12 |
| Number of Days > 20 Hours | 0 |

Note: The last two lines will only appear on the master (A1) display.

System Time

Number of hours the system has been operational. This number is counted by Quad controller module A.

Backlight Time

Number of hours that the LCD has been turned on. This information is stored in the LCD interface board.

Average Hours Per Day

Shows the average number of hours per day an LCD has been on.

Number of Days > 20 Hours

Shows the number of days that an LCD display has been on more than 20 hours per day. This feature helps installers keep displays within the normal use thermal guidelines. For more information, see "Normal Use Thermal Guidelines" on page 6.

Communicating via Network

The Quad Controller Module may have an optional device known as WallNet that allows remote monitoring of the status of various components in the wall. WallNet is used to display information about a wall of displays via a web browser. When first plugged in, it utilizes DHCP to obtain an IP address. Upon failing to obtain an IP address, it defaults to a static IP address of 192.168.12.12. For more detailed information, refer to document 020-1260-00, User Guide, WallNet2, Matrix G2.

Note: For communication to work, the external LAN *must* know the IP address of the Quad Controller which is shown in the Networking menu (MAIN MENU > DIAGNOSTICS > NETWORKING).

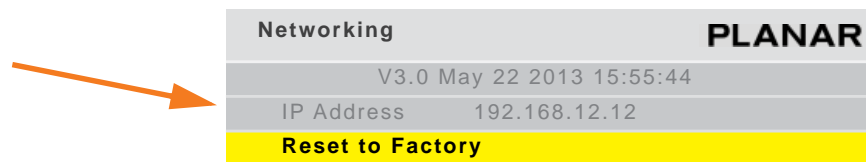

Note: This option must reside on the master Quad Controller to function properly.

Saving and Recalling Configurations

Advantages of Saving Configurations to Memory Slots

- You can compare multiple settings quickly
- You don't have to repeat settings when comparing entire configurations
- You can revert to a known good setting when testing new configurations

What the Memories Store

The following settings can be stored in a memory slot and recalled when needed:

- Selected source
- Resolution (and much more about the signal)
- Sharpness
- Position and size (zoom settings)
- Everything in the ASPECT RATIO menu
- Brightness, Contrast, Hue and Saturation for video sources

All of this is stored separately for each memory slot. As an example, you could store multiple different wall setups and switch between them quickly.

Global Storage

The following settings are stored globally; that is, they are stored at the display level and are the same for all memory slots.

- Everything in the MISCELLANEOUS OPTIONS menu
- All the HOURS settings
- All the COLOR BALANCE settings

Memory: What Is Saved? And Where?

In the display, some parameters (values) are associated with the mode. The mode is primarily the horizontal and vertical resolution and the vertical frequency of the incoming source picture. It is more than that, but if you think of it this way, you will be close enough. Some parameters are associated with the input. The parameters specific to mode and input are saved in memory slots.

Some parameters are global. They are independent of the mode or input, and are not saved to memory slots, as shown in the table below.

| Parameter | Saved in Slot | Global |
|----------------------------|---------------|--------|
| ASCII Response Term. | | x |
| ASCII Response Type | | x |
| Auto Backlight On | | x |
| Baud Rate | | x |
| Black Level: R, G & B | x | |
| Brightness (video) | x | |
| Color Balance (all values) | | x |
| Contrast (video) | x | |
| Hue | x | |
| Justify | x | |
| Menu Timeout | | x |
| Overscan | x | |
| Plug and Play (EDID) | | x |
| Position, Horizontal | x | |
| Position, Vertical | x | |
| Saturation | x | |

| Parameter | Saved in Slot | Global |
|------------------------|---------------|--------|
| Sharpness | x | |
| Viewport Window Bottom | x | |
| Viewport Window Left | x | |
| Viewport Window Right | x | |
| Viewport Window Top | x | |
| Wall Height | x | |
| Wall Mode | x | |
| Wall Unit Column | x | |
| Wall Unit Row | x | |
| Wall Width | x | |
| White Level: R, G & B | x | |
| Zoom Window Bottom | x | |
| Zoom Window Left | x | |
| Zoom Window Right | x | |
| Zoom Window Top | x | |

Saving Configurations

- 1 Set up the wall the way you want it.
- 2 Press the SAVE button twice.

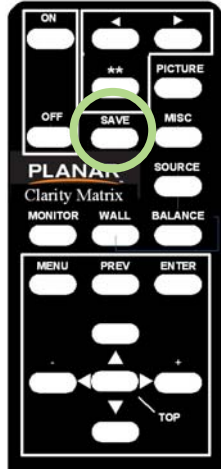

| Save | | PLANAR | | | | | | | |
|--------------------------|---|--------------------------|----|--------------------------|----|--------------------------|----|--------------------------|----|
| <input type="checkbox"/> | 1 | <input type="checkbox"/> | 9 | <input type="checkbox"/> | 17 | <input type="checkbox"/> | 25 | <input type="checkbox"/> | 33 |
| <input type="checkbox"/> | 2 | <input type="checkbox"/> | 10 | <input type="checkbox"/> | 18 | <input type="checkbox"/> | 26 | <input type="checkbox"/> | 34 |
| <input type="checkbox"/> | 3 | <input type="checkbox"/> | 11 | <input type="checkbox"/> | 19 | <input type="checkbox"/> | 27 | <input type="checkbox"/> | 35 |
| <input type="checkbox"/> | 4 | <input type="checkbox"/> | 12 | <input type="checkbox"/> | 20 | <input type="checkbox"/> | 28 | <input type="checkbox"/> | 36 |
| <input type="checkbox"/> | 5 | <input type="checkbox"/> | 13 | <input type="checkbox"/> | 21 | <input type="checkbox"/> | 29 | <input type="checkbox"/> | 37 |
| <input type="checkbox"/> | 6 | <input type="checkbox"/> | 14 | <input type="checkbox"/> | 22 | <input type="checkbox"/> | 30 | <input type="checkbox"/> | 38 |
| <input type="checkbox"/> | 7 | <input type="checkbox"/> | 15 | <input type="checkbox"/> | 23 | <input type="checkbox"/> | 31 | <input type="checkbox"/> | 39 |
| <input type="checkbox"/> | 8 | <input type="checkbox"/> | 16 | <input type="checkbox"/> | 24 | <input type="checkbox"/> | 32 | <input type="checkbox"/> | 40 |

The SAVE grid menu displays. This menu contains 40 numbered memory slots.

- 3 Using the arrow keys on the remote, navigate to a slot:
 - An unchecked slot number allows you to save new settings.
 - A checked slot has settings already saved to it. If you want, you can overwrite what's already saved.
- 4 Press ENTER. The SAVE SLOT menu displays.

| Save | | PLANAR | | |
|-------------------|--------------------------------|---------|-----|--|
| Slot Number | (Current) | 1 | | |
| Save Now | (will overwrite occupied slot) | | | |
| Name | DI 1920x1080 | | | |
| Source | Digital | | | |
| Colorspace | RGB | | | |
| Resolution | 1920 x 1080 | | | |
| Wall | 2 x 2 | 1:1 | | |
| Scale/Justify | One to One / Center | | | |
| Position/Overscan | 168,19 / 0% | | | |
| Zoom UL/ LR | +0,+0 | / +0,+0 | | |
| Viewport UL/LR | +0,+0/ | +0,+0 | | |
| Frequency/Phase | 1602 / 22.5° | | | |
| Sharpness | Normal | | | |
| Black Level | 63 | 55 | 57 | |
| White Level | 166 | 170 | 169 | |

Note: This menu shows all the settings that will be saved. You can't change anything but the name in this menu. The appearance of this menu is somewhat different for digital and video sources, reflecting what is saved for them.

- a If the current settings exactly match what is already in the memory, (CURRENT) will appear in the SLOT NUMBER line.
 - b If the memory already had data, and the only change is to the name, the phrase "will update name of occupied slot" appears in the SAVE NOW line.
 - c If this memory already has something stored in it, the phrase "will overwrite occupied slot" appears in red on the SAVE NOW line. This is the only warning.
 - d If none of these messages appear, this slot is empty.
- 5 Select SAVE NOW and press ENTER. The display instantly stores all the current settings into that memory slot.

Changing the Name of the Memory Slot

The default name is an abbreviation of the source connector, resolution, and if Wall Mode is on, wall settings. In the following example, the name tells you that the source is connected to Digital, which displays 1920 x 1080, is part of a 2 x 2 array, and is the display in the upper left corner (column 1, row 1).

- 1 If you want a more descriptive name, select NAME and press ENTER. A little bar appears beneath the NAME line.

| Save | | PLANAR | |
|-------------------|----------------------|--------|-----|
| Slot Number | 1 | | |
| Save Now | | | |
| Name | DI 1920x1080 2x2 1:1 | | |
| Source | Digital | | |
| Colorspace | RGB | | |
| Resolution | 1920 x 1080 | | |
| Wall | 2 x 2 | 1:1 | |
| Scale/Justify | One to One / Center | | |
| Position/Overscan | 168,19 / 0% | | |
| Zoom UL/ LR | +0,+0 / | +0,+0 | |
| Viewport UL/LR | +0,+0/ | +0,+0 | |
| Frequency/Phase | 1602 / 22.5° | | |
| Sharpness | Normal | | |
| Black Level | 63 | 55 | 57 |
| White Level | 166 | 170 | 169 |

- a Use the + or - keys to move the yellow selector under the character you want to change.
 - b Use the up/down arrows to change the character.
- 2 When you are finished, press PREV.
 - 3 Select SAVE NOW and press ENTER.

Note: If you use RS232 controls, you can also use commands to send a string name to a memory slot, saving time.

Recalling Stored Configurations



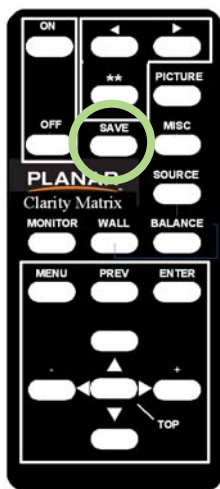



- 1 Press SAVE once to open the RECALL GRID menu.



| Recall | | | | PLANAR | | | | | |
|-------------------------------------|---|-------------------------------------|----|-------------------------------------|----|--------------------------|----|--------------------------|----|
| <input checked="" type="checkbox"/> | 1 | <input checked="" type="checkbox"/> | 9 | <input checked="" type="checkbox"/> | 17 | <input type="checkbox"/> | 25 | <input type="checkbox"/> | 33 |
| <input checked="" type="checkbox"/> | 2 | <input checked="" type="checkbox"/> | 10 | <input type="checkbox"/> | 18 | <input type="checkbox"/> | 26 | <input type="checkbox"/> | 34 |
| <input type="checkbox"/> | 3 | <input checked="" type="checkbox"/> | 11 | <input type="checkbox"/> | 19 | <input type="checkbox"/> | 27 | <input type="checkbox"/> | 35 |
| <input type="checkbox"/> | 4 | <input type="checkbox"/> | 12 | <input type="checkbox"/> | 20 | <input type="checkbox"/> | 28 | <input type="checkbox"/> | 36 |
| <input type="checkbox"/> | 5 | <input type="checkbox"/> | 13 | <input type="checkbox"/> | 21 | <input type="checkbox"/> | 29 | <input type="checkbox"/> | 37 |
| <input type="checkbox"/> | 6 | <input type="checkbox"/> | 14 | <input type="checkbox"/> | 22 | <input type="checkbox"/> | 30 | <input type="checkbox"/> | 38 |
| <input type="checkbox"/> | 7 | <input type="checkbox"/> | 15 | <input type="checkbox"/> | 23 | <input type="checkbox"/> | 31 | <input type="checkbox"/> | 39 |
| <input type="checkbox"/> | 8 | <input type="checkbox"/> | 16 | <input type="checkbox"/> | 24 | <input type="checkbox"/> | 32 | <input type="checkbox"/> | 40 |

- 2 Navigate to the slot you want to recall. When navigating, you can only go to the checked numbers. All the slots with checks have something stored in them. The others are grayed out.

- 3 Press ENTER to open the RECALL SLOT menu.

| Recall | | PLANAR | | |
|---|---------------------|---------------|-----|--|
| Slot Number | | 17 | | |
| Recall Now | | | | |
| Name | DI 1920x1080 | | | |
|  Source | Digital | | | |
|  Colorspace | RGB | | | |
|  Resolution | 1920 x 1080 | | | |
| Wall | 2 x 2 | 1:1 | | |
| Scale/Justify | One to One / Center | | | |
| Position/Overscan | 168,19 / 0% | | | |
| Zoom UL/ LR | +0,+0 / | +0,+0 | | |
| Viewport UL/LR | +0,+0 / | +0,+0 | | |
|  Frequency/Phase | 1602 / 22.5° | | | |
|  Sharpness | Normal | | | |
|  Black Level | 63 | 55 | 57 | |
|  White Level | 166 | 170 | 169 | |

Note: If this slot number has exactly the same settings that are currently being used, a (CURRENT) message appears on the top line.

The name of the memory is listed here, as well as all the important parameters (data) stored in that memory slot.

- 4 If the name is *not* the one you want, press PREV and choose another memory.
- 5 In the RECALL SLOT menu, RECALL NOW is selected. Press ENTER to recall the parameters currently displayed in the menu.
- 6 We suggest that you create a list of memory slots that contains each slot number, name and description.

Deleting a Configuration

- 1 Go to the MEMORY menu (MAIN MENU > MEMORY).







| | |
|---------------|---------------|
| Memory | PLANAR |
| Recall | ▶ |
| Save | ▶ |
| Delete | ▶ |

- 2 Select DELETE and press ENTER.
This opens the DELETE grid menu with 40 numbered memory slots.

| | | | | | | |
|---------------------------------------|--|--|-----------------------------|-----------------------------|--|--|
| Delete | PLANAR | | | | | |
| <input checked="" type="checkbox"/> 1 | <input checked="" type="checkbox"/> 9 | <input checked="" type="checkbox"/> 17 | <input type="checkbox"/> 25 | <input type="checkbox"/> 33 | | |
| <input checked="" type="checkbox"/> 2 | <input checked="" type="checkbox"/> 10 | <input type="checkbox"/> 18 | <input type="checkbox"/> 26 | <input type="checkbox"/> 34 | | |
| <input type="checkbox"/> 3 | <input checked="" type="checkbox"/> 11 | <input type="checkbox"/> 19 | <input type="checkbox"/> 27 | <input type="checkbox"/> 35 | | |
| <input type="checkbox"/> 4 | <input type="checkbox"/> 12 | <input type="checkbox"/> 20 | <input type="checkbox"/> 28 | <input type="checkbox"/> 36 | | |
| <input type="checkbox"/> 5 | <input type="checkbox"/> 13 | <input type="checkbox"/> 21 | <input type="checkbox"/> 29 | <input type="checkbox"/> 37 | | |
| <input type="checkbox"/> 6 | <input type="checkbox"/> 14 | <input type="checkbox"/> 22 | <input type="checkbox"/> 30 | <input type="checkbox"/> 38 | | |
| <input type="checkbox"/> 7 | <input type="checkbox"/> 15 | <input type="checkbox"/> 23 | <input type="checkbox"/> 31 | <input type="checkbox"/> 39 | | |
| <input type="checkbox"/> 8 | <input type="checkbox"/> 16 | <input type="checkbox"/> 24 | <input type="checkbox"/> 32 | <input type="checkbox"/> 40 | | |

- 3 Navigate with the arrow keys to the slot you want to delete and press ENTER.
When navigating, you can only go to the checked numbers. All the slots with checks have something stored in them. The others are grayed out.

4 In the DELETE SLOT menu, DELETE NOW is selected.

| Delete | | PLANAR | |
|---|---------------------|--------|-------|
| Slot Number | 17 | | |
| Delete Now | | | |
| Name | DI 1920x1080 | | |
|  Source | Digital | | |
|  Colorspace | RGB | | |
|  Resolution | 1920 x 1080 | | |
| Wall | 2 x 2 | 1:1 | |
| Scale/Justify | One to One / Center | | |
| Position/Overscan | 168,19 / 0% | | |
| Zoom UL/ LR | +0,+0 | / | +0,+0 |
| Viewport UL/LR | +0,+0/ | +0,+0 | |
|  Frequency/Phase | 1602 / 22.5° | | |
|  Sharpness | Normal | | |
|  Black Level | 63 | 55 | 57 |
|  White Level | 166 | 170 | 169 |

5 Press ENTER.

| Confirm Slot Delete | | PLANAR | |
|---------------------|-----|--------|--|
| Are you Sure? | Yes | No | |

6 Use the left arrow to make the YES red and press ENTER.

| Confirm Slot Delete | | PLANAR | |
|---------------------|-----|--------|--|
| Are you Sure? | Yes | No | |

Note: It is not necessary to delete the data in a memory slot before saving new data. Saving will overwrite the stored data. (See "Saving Configurations" on page 113)

Understanding Wall Configuration

The Matrix system is quite flexible. Its digital inputs can be displayed on the LCD modules in a variety of ways. However, it is not quite as flexible as a high-cost matrix switcher system. This section contains examples of common scenarios that can be accomplished with the Matrix system.

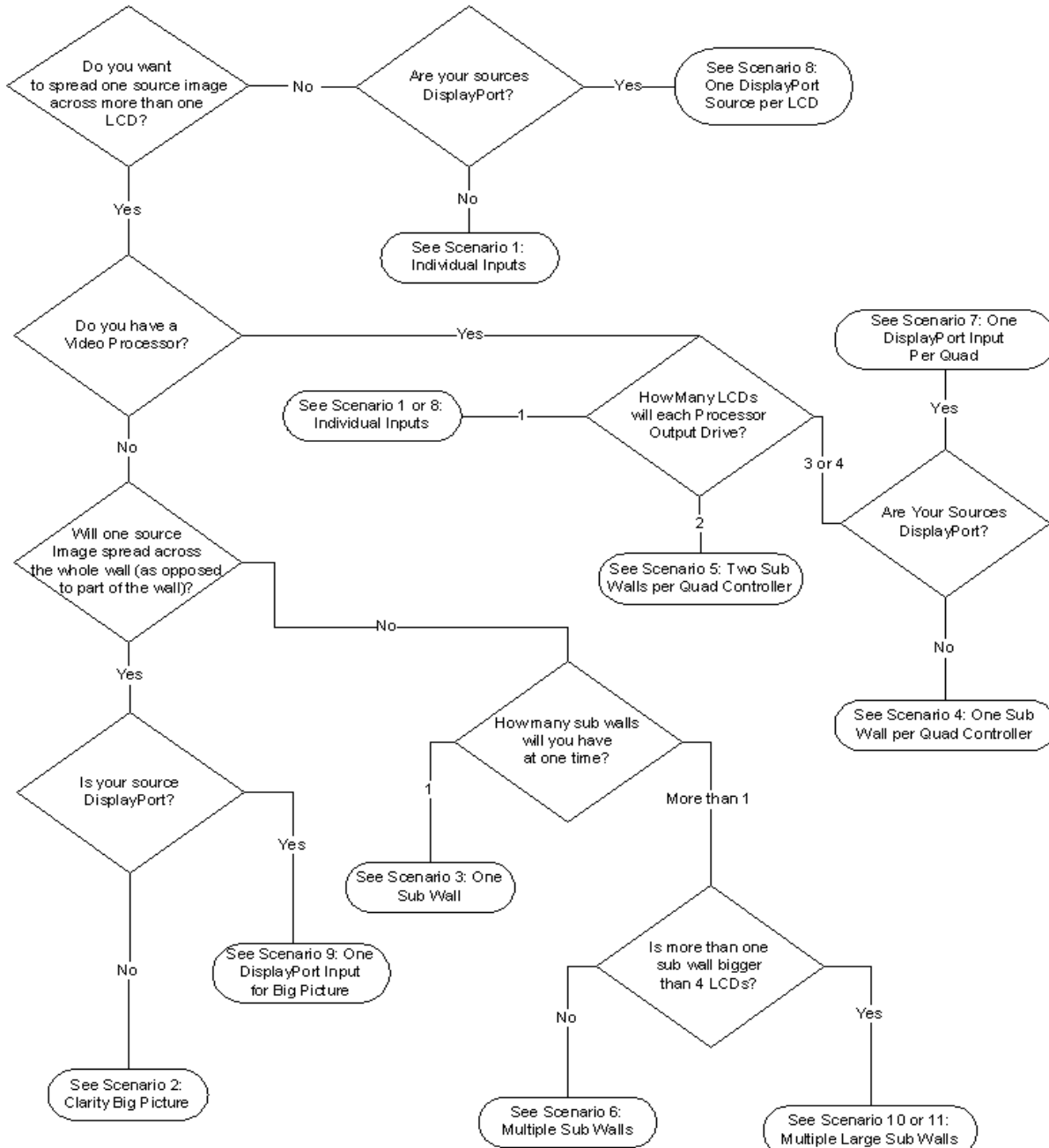

Configuration Scenarios

Read through the following scenarios and use the flowchart on the previous page to find the ones that apply to your installation. If you fall into more than one scenario, make sure that the cabling of the system is the same for all of your configurations.

Configuration of a wall can be broken down into three parts: *cabling*, *source routing* and *wall configuration*.

Cabling consists of how the LCD modules are connected to the Quad controller modules, how the Quad controller modules Dual Link In and Loop Out connections are made and how the sources are connected to the Digital inputs.

Source Routing consists of configuring the internal video switches on each Quad controller module. These switches control which inputs are displayed on which outputs within the Quad controller module and are set on the quad module route menu. For most of the scenarios, it is not necessary to know the details of how these switches are set, but for more complex scenarios, it is necessary to understand these switches. For an example of the quad module route menu, see "Understanding the Quad Module Route Menu" on page 138.

Wall Configuration consists of setting up the scaling chips in each of the four processors on the Quad controller module so the correct piece of the image is displayed on each LCD. Because the Clarity Matrix has position sensors, these settings can be done automatically in many of the scenarios.

Standard Cabling Scenarios

Scenarios 1, 2 and 3 all use what we call standard cabling. It does not matter which LCDs are cabled to which Quad controller module. Scenarios 2 & 3 require standard loop through cabling, as shown on page 122.

Scenario 1: Individual Inputs

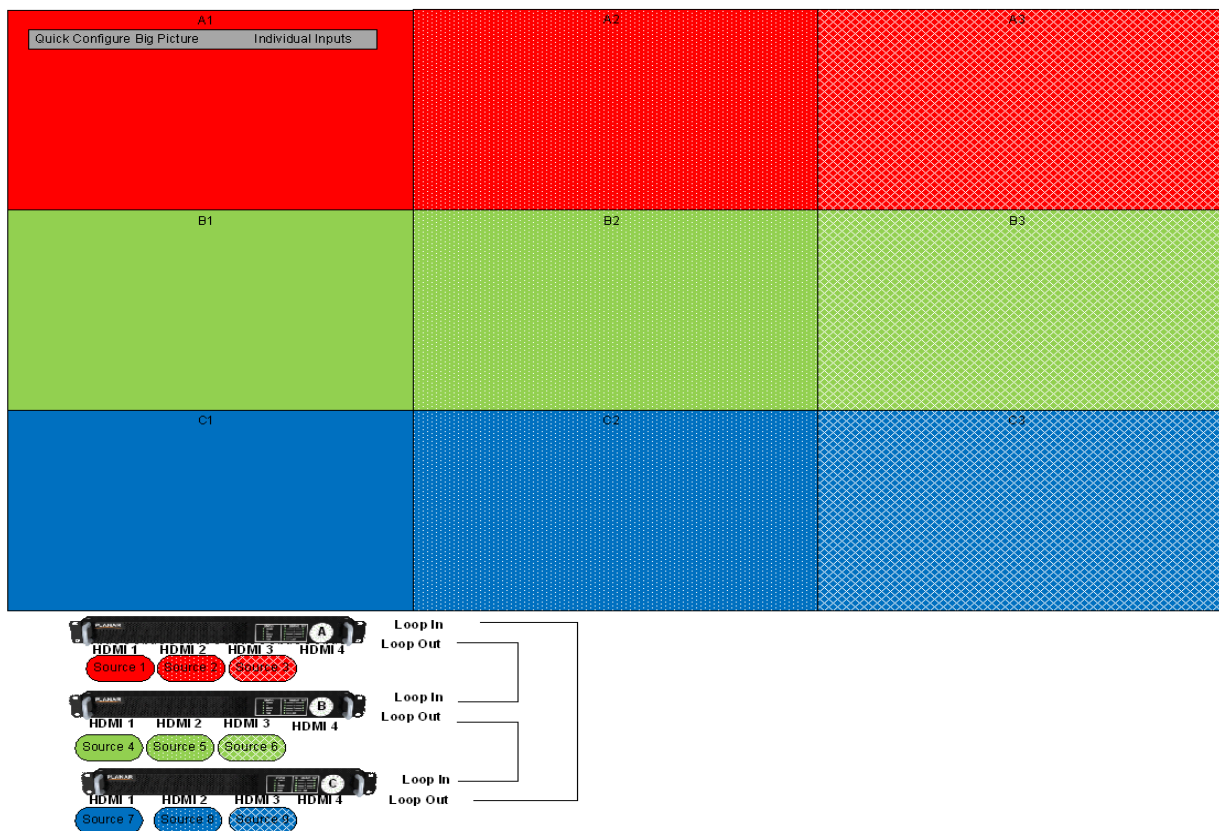

3 x 3 wall with individual inputs

The simplest way to configure a Clarity Matrix system is where each LCD displays the video from one and only one of the inputs. This scenario will be used most often with a video processor such as a Magenta Processor.

Cabling To cable a system for individual inputs, keep in mind that you will need to be able to tell your video processor which inputs are in which position. So you will probably want to put the displays in some logical order in the Quad controller modules. If you have unused LCD connectors in your Quad controller module, do not use those corresponding inputs. The above example shows the cabling for this scenario. There is no need to cable the Loop Out or Dual Link In connectors for this scenario.

Source Routing There is a quick configuration for this scenario. In order to route the sources for individual inputs, choose "No BP" from the bottom right corner of the QUICK CONFIGURE menu.

Wall Settings Big Picture is not used in this scenario, so WALL MODE should be set to off on the BIG PICTURE SETUP menu for all displays. The Quick Configure setting takes care of this for you.

Scenario 2: Clarity Big Picture

When in Clarity Big Picture, one source is spread over the entire wall. In the Clarity Matrix product, any input can easily be used as the source for Big Picture.

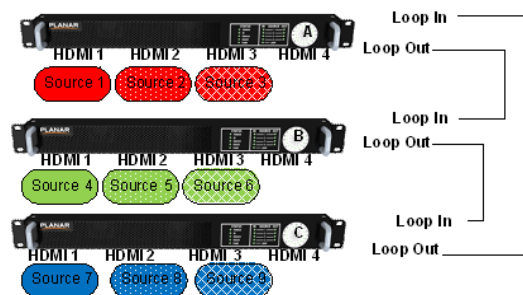

3 x 3 wall using Clarity Big Picture. Any input can be spread over the whole wall.

Cabling Because the Clarity Matrix has position sensing, LCDs can be cabled to the Quad controller modules in any way that is convenient. Keep in mind that most of the configuration menus will appear on the module connected to LCD 1 on the A Quad controller module, so you may want to put that one in a convenient location.

The Loop out connector of each Quad controller module should be connected to one of the Loop In connectors of the next module. The final Loop Out connector should be connected back to one of the Digital In connectors on the first module.

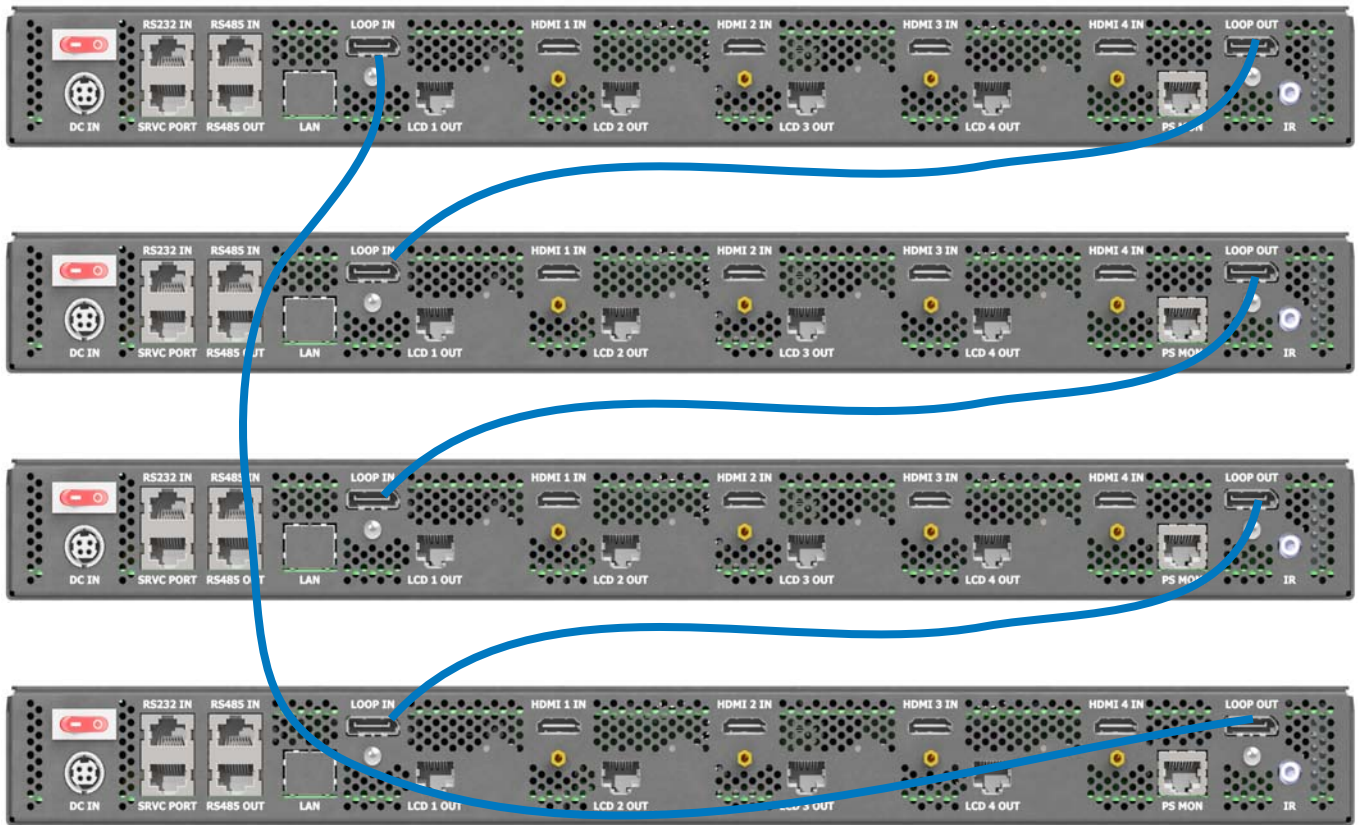

Source Routing There is a quick configuration for Clarity Big Picture. Choose the input you want to display on the whole wall for the QUICK CONFIGURE BIG PICTURE line in the WALL CONFIGURATION menu. In order for this Quick Configure to work correctly, you must have previously allowed the system to discover its display positions by choosing AUTO in the MATRIX LAYOUT menu.

Wall Configuration Each display's wall configuration is set up automatically by the Quick Configure setting. Wall Mode is turned on, the wall width and wall height is set to the width and height of the Matrix, and each display's row and column are set according to its position.

Scenario 3: One Sub Wall and Individual Inputs

In this scenario, one input is spread over multiple LCDs, while the rest of the LCDs display individual inputs. This scenario may be used in a control room, where each display is monitoring a particular source, and at a command, one input may be magnified for more detailed viewing. The size of the sub wall in this scenario does not matter. Two of the examples show a 2 x 2 sub wall in a 3 x 3 Matrix, but you could also have a 3 x 5 sub wall in a 6 x 6 wall, or any other configuration. The restriction is that there is only one sub wall in the Matrix. The other displays are showing individual inputs.

Cabling The cabling for this scenario is the same as for the Big Picture scenario. The Quad controller modules must be looped together by use of the Loop In and Loop Out connectors (see page 135 for an example). There is no restriction on which displays are connected to which Quad controller modules, but you will want to cable them in an orderly fashion so it is easy for you to associate each input with a particular Quad controller module.

Source Routing There are no quick configure settings for this scenario. You will need to set up the source routing and wall settings for each sub wall configuration and save those settings to a slot (see "Saving Configurations" on page 113). To set up source routing, use the QUAD MODULE ROUTE menu for each Quad controller module. This menu has two parts, each of which gives a different view of the same settings. If you use one part of the menu, the other will automatically update. The following diagrams use only the lower part of the menu. For simplicity, the rest of the menu is not shown.

In the following diagrams, the settings from the QUAD MODULE ROUTE menu are shown on the side of the diagram and these menus will appear on display A1.

Wall Settings Once the source is routed, you still need to tell each processor which portion of the source to show. This is done in the BIG PICTURE SETUP menu on each processor. An LCD that is displaying an individual source should have WALL MODE turned off. An LCD that is part of a sub wall should have its height and width parameters set to the sub wall height and width, and its unit row and column parameters set to the row and column within that sub wall.

In the diagrams that follow, a darkened bar over a settings means that setting is not necessary for this scenario and it doesn't matter to what it is set.

| Quad Module Route A | |
|---------------------|---------------|
| Switch 1 | External Loop |
| Switch 2 | External Loop |
| Switch 3 | Digital 3 |
| Switch 4 | Loop |
| Internal Loop | Digital 1 |
| External Loop | Digital 1 |

| Quad Module Route B | |
|---------------------|---------------|
| Switch 1 | External Loop |
| Switch 2 | External Loop |
| Switch 3 | Digital 3 |
| Switch 4 | Digital 4 |
| Internal Loop | Digital 1 |
| External Loop | DPort In |

| Quad Module Route C | |
|---------------------|-----------|
| Switch 1 | Digital 1 |
| Switch 2 | Digital 2 |
| Switch 3 | Digital 3 |
| Switch 4 | Digital 4 |
| Internal Loop | Digital 1 |
| External Loop | DPort In |

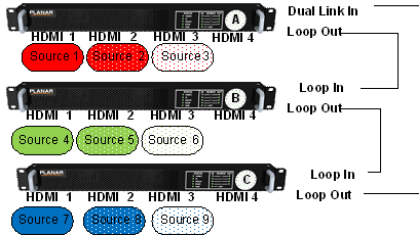

3 x 3 Matrix with 2 x 2 sub wall, upper left displaying source A1.

| Quad Module Route A | |
|---------------------|-----------|
| Switch 1 | Digital 1 |
| Switch 2 | Digital 2 |
| Switch 3 | Digital 3 |
| Switch 4 | Loop |
| Internal Loop | Digital 1 |
| External Loop | DPort In |

| Quad Module Route B | |
|---------------------|---------------|
| Switch 1 | Digital 1 |
| Switch 2 | Digital 2 |
| Switch 3 | External Loop |
| Switch 4 | Digital 4 |
| Internal Loop | Digital 1 |
| External Loop | DPort In |

| Quad Module Route C | |
|---------------------|---------------|
| Switch 1 | Digital 1 |
| Switch 2 | External Loop |
| Switch 3 | External Loop |
| Switch 4 | Digital 4 |
| Internal Loop | Digital 1 |
| External Loop | DPort In |

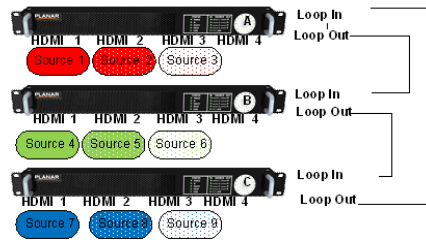
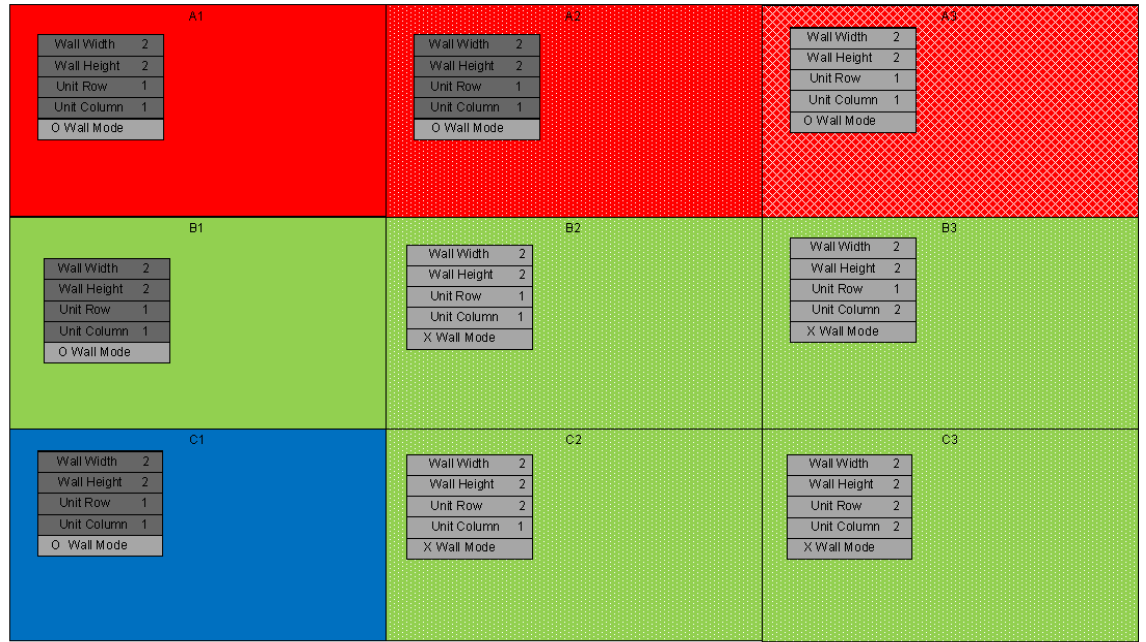

3 x 3 Matrix with 2 x 2 sub wall, lower right displaying source B2.

| Quad Module Route A | |
|---------------------|-----------|
| Switch 1 | Digital 1 |
| Switch 2 | Digital 2 |
| Switch 3 | Digital 3 |
| Switch 4 | Loop |
| Internal Loop | Digital 1 |
| External Loop | DPort In |

| Quad Module Route B | |
|---------------------|---------------|
| Switch 1 | External Loop |
| Switch 2 | External Loop |
| Switch 3 | Digital 3 |
| Switch 4 | Digital 4 |
| Internal Loop | Digital 1 |
| External Loop | DPort In |

| Quad Module Route C | |
|---------------------|---------------|
| Switch 1 | External Loop |
| Switch 2 | External Loop |
| Switch 3 | Digital 3 |
| Switch 4 | Digital 4 |
| Internal Loop | Digital 1 |
| External Loop | DPort In |

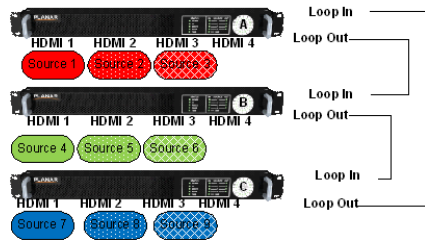
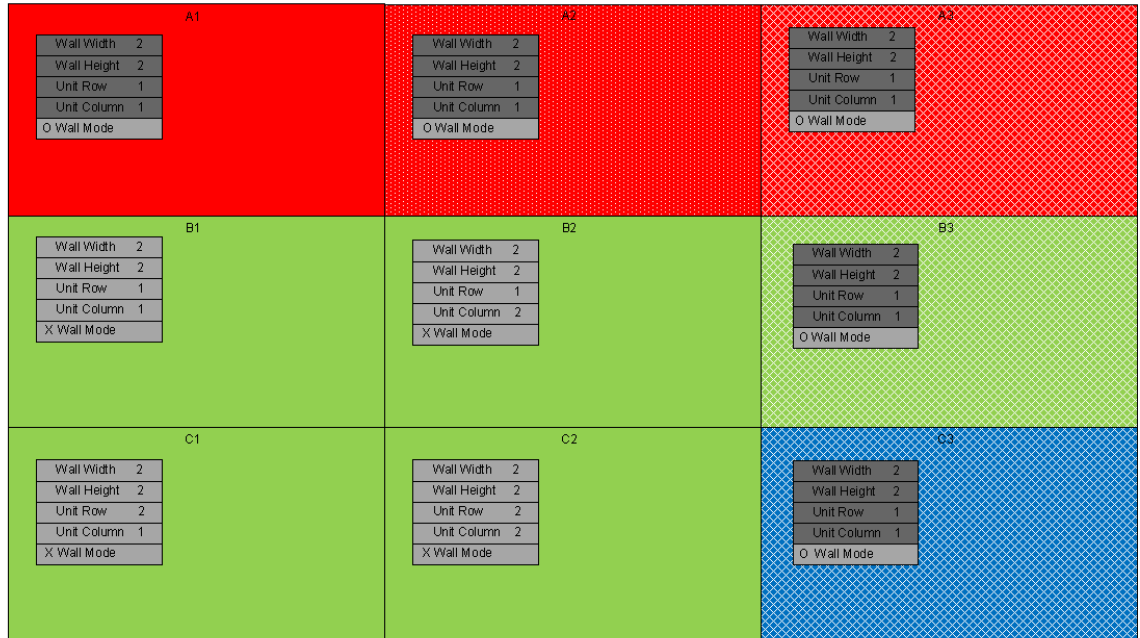

3 x 3 Matrix with 2 x 2 sub wall, lower left displaying source B1.

Standard Cabling with Restrictions on LCD Placement

Scenario 4: One Sub Wall Per Quad Controller

This scenario uses an external video processor, but saves on the number of outputs required for that processor. Each output of the processor drives four LCDs.



4 x 4 Matrix with one source per Quad controller module.

Cabling Cable the LCDs so each Quad controller module controls a 2 x 2 square of LCDs. The order within the square does not matter because the position sensors will be used. Cable each output of the video processor to the same numbered input in each Quad controller module. This could be Digital 1, Digital 2, Digital 3 or Digital 4. It is not necessary to cable the Loop Out connector of the Quad controller module.

Source Routing The Quick Configure Quad setting in the WALL CONFIGURATION menu is used to configure this scenario. If you have cabled the sources to Digital 1, use Quick Configure Quad 1, if you have cabled the sources to Digital 2, use Quick Configure Quad 2 etc.

Wall Settings By choosing the Quick Configure, the system will configure each LCD automatically. Because the settings are different for each LCD, the system must send many commands to each LCD. Quick Configure Quad takes a bit longer to respond than other Quick Configure settings. Note that the LCDs connected to each Quad controller module must be in a rectangle. If they are not, the wall settings will not be set, although the source routing will still take place. The rectangle does not have to be 2 x 2. For example, a wall may not have even multiples of four LCDs. Quick Configure Quad will set the wall parameters to the number and size of LCDs on that Quad controller module, be it 2 x 1, 1 x 2, 1 x 3 etc. The external video processor outputs must be configured accordingly.

Scenario 5: Two Sub Walls Per Quad Controller

This scenario uses an external video processor, but saves on the number of outputs required for that processor. Each output of the processor drives two LCDs.

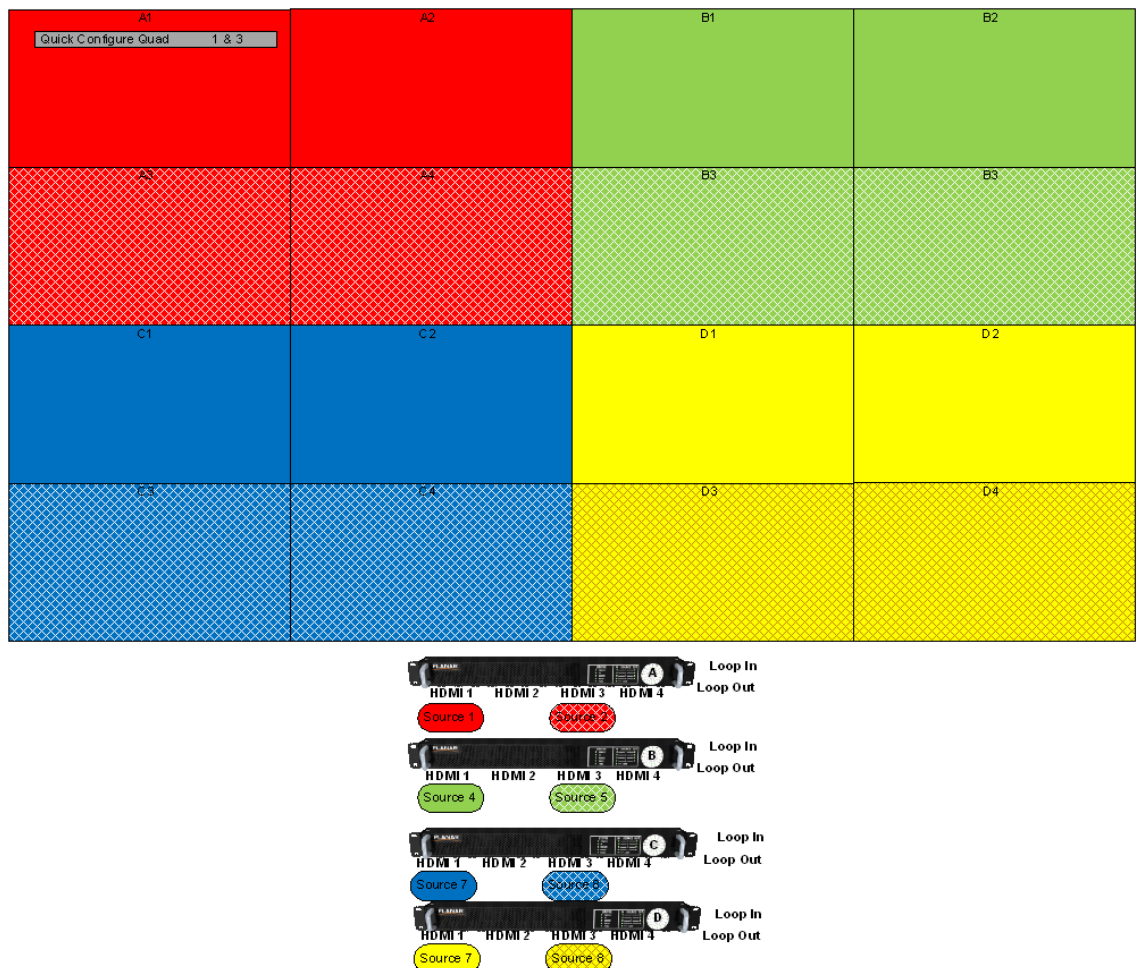

4 x 4 Matrix with two high resolution sources per Quad controller module.

Cabling Cable the LCDs so that each pair of LCDs you will use for a sub wall are adjacent to each other. These can be 1 x 2 or 2 x 1 rectangles; the position sensors will be used to determine how they are arranged. Cable the outputs of the video Digital 1 and Digital 3. The source on Digital 1 will be spread over LCD 1 and LCD 2. The source on Digital 3 will be spread over LCD 3 and LCD 4. It is not necessary to cable the Loop Out connector of the Quad controller module.

Source Routing The Quick Configure Quad setting in the WALL CONFIGURATION menu is used to configure this scenario. Use Quick Configure Quad 1 & 3.

Wall Settings By choosing the Quick Configure, the system will configure each LCD automatically. Because the settings are different for each display, the system must send many commands to each LCD. Quick Configure Quad takes a bit longer to respond than other Quick Configure settings.

Scenario 6: Multiple Sub Walls

It is possible to have more than one sub wall at one time on a Clarity Matrix Video Wall if certain rules are followed:

- One sub wall can be any size and use any input. This sub wall will use the External Loop.
- All the other sub walls must fit within a single Quad controller module. This means they will be 2 x 2 or smaller.

| Quad Module Route A | |
|---------------------|---------------|
| Switch 1 | Digital 1 |
| Switch 2 | External Loop |
| Switch 3 | External Loop |
| Switch 4 | External Loop |
| Internal Loop | Digital 1 |
| External Loop | DPort In |

| Quad Module Route B | |
|---------------------|---------------|
| Switch 1 | External Loop |
| Switch 2 | External Loop |
| Switch 3 | External Loop |
| Switch 4 | External Loop |
| Internal Loop | Digital 3 |
| External Loop | DPort In |

| Quad Module Route C | |
|---------------------|---------------|
| Switch 1 | External Loop |
| Switch 2 | External Loop |
| Switch 3 | External Loop |
| Switch 4 | Digital 4 |
| Internal Loop | Digital 1 |
| External Loop | DPort In |

| Quad Module Route D | |
|---------------------|---------------|
| Switch 1 | External Loop |
| Switch 2 | External Loop |
| Switch 3 | Digital 3 |
| Switch 4 | External Loop |
| Internal Loop | Digital 1 |
| External Loop | DPort In |

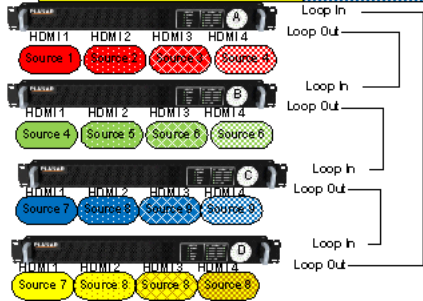

4 x 4 Matrix with one large and one small sub wall.

Cabling Cluster the displays into the groups where you want the small sub walls, and cable each sub wall to a single Quad controller module. Cable the Loop Out of each Quad controller module to the Loop In of the next module and loop the last Loop Out into the Dual Link In of the first module.

Source Routing For the Quad controller modules that are displaying a small sub wall, set each switch to Loop, Use Internal Loop and set the Internal Loop to the display you want to view on that sub wall.

For each display that is part of the large sub wall, set each switch to Loop, and Use External Loop.

Set the External Loop of the Quad controller module that contains the source for the large sub wall to that source. Set the External Loop of all the other Quad controller modules to Loop In.

Wall Settings Set the height and width for each display within a sub wall to the height and width of that sub wall and set the unit row and unit column as appropriate.

DisplayPort Input Scenarios

Only one of the inputs on the Quad controller module is a DisplayPort Input. The DisplayPort Input can either be used as a loop mechanism or as an input but not both. Because of this, systems that use scenarios 7 and 8 cannot also use any of the other scenarios.

Scenario 7: One DisplayPort Input per Quad Controller Module

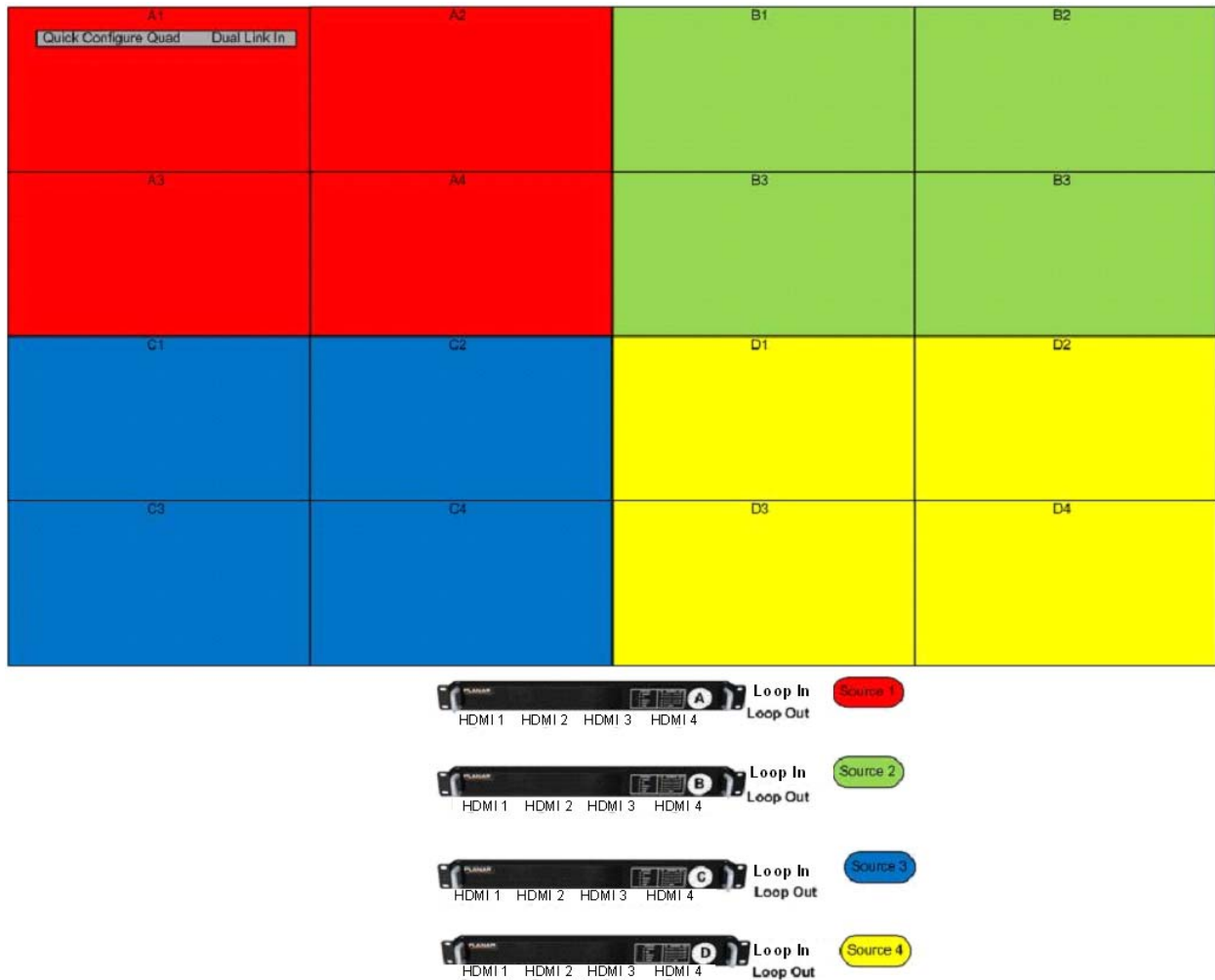

4 x 4 Matrix with one DisplayPort source per Quad Controller Module.

Scenario 8: One DisplayPort Source per LCD

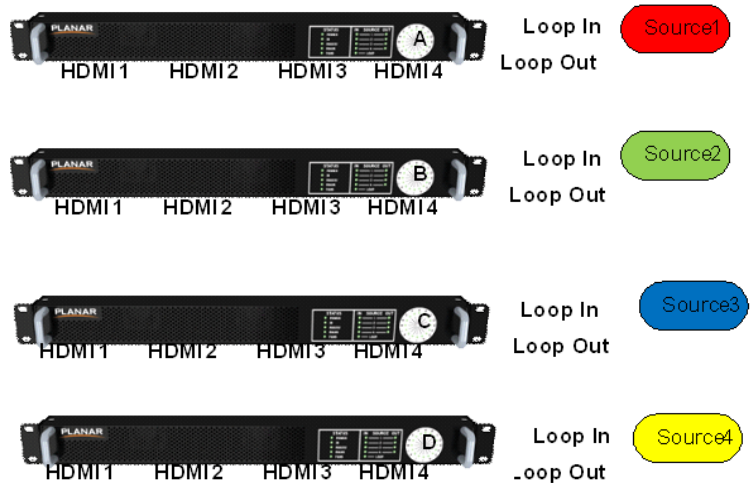
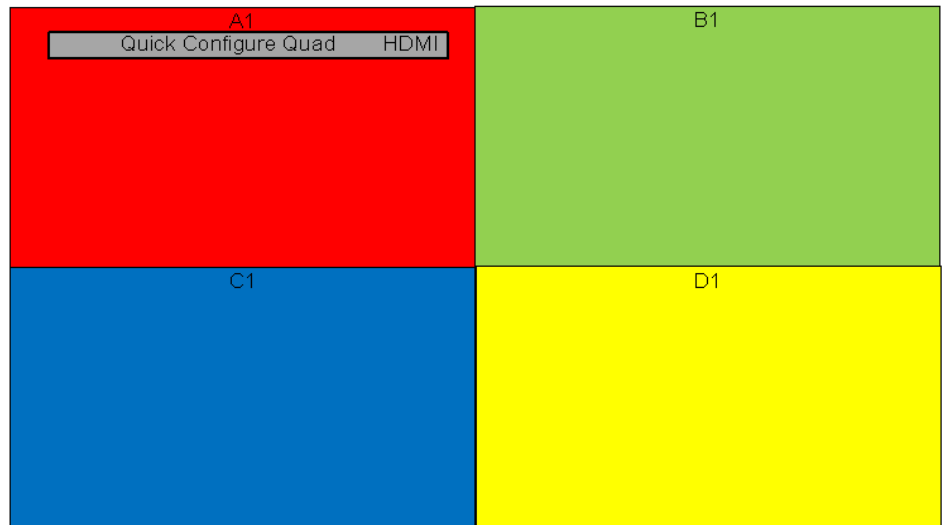

2 x 2 Matrix with one dual link source per LCD.

Cabling Cable each DisplayPort output of the video processor to the Loop In of each Quad controller module. It is not necessary to cable the Loop Out connector of the Quad controller module.

Source Routing The QUICK CONFIGURE QUAD setting in the WALL CONFIGURATION menu is used to configure this scenario. Choose Dp from the bottom line of the Quick Configure menu. Note that there are two boxes on this menu marked Dp: the one on the bottom line sets the Big Picture settings for individual inputs.

Wall Settings By choosing the Quick Configure, the system will configure each display automatically.

Scenario 9: One DisplayPort Input for Big Picture

If you want to spread a DisplayPort source over the whole wall, you only need one DisplayPort Input, because the others are used to loop the signal.



3 x 3 Matrix with dual link source Big Picture.

Cabling Cable the source into the first Quad controller module and then cable the Loop Out to the Loop In on the rest of the modules.

Source Routing Every Switch in Every Quad controller module should be set to External Loop. The External Loop should be set to DPort In.

Wall Settings There is a quick configuration setting for this scenario. Choose the Dp square on the second line from the bottom in the Quick Configuration menu.

Complex Configurations

It is possible to design systems that don't fall into any of the above scenarios, but not all combinations of inputs on sub walls are possible. A system cabled for such a complex configuration may or may not be able to also have some of the simpler configurations.

Scenario 10: Multiple Large Sub Walls

The previous scenario was restricted such that only one sub wall in a Matrix could be larger than a single Quad controller module. If you want more than one sub wall that is larger than four displays, there are certain restrictions. You must cable the loop connections sequentially among the Quad controller modules that make up each sub wall. Since a sub wall that spans more than one Quad controller module uses the external loop, a sub wall is restricted to using inputs from only the first Quad controller module in the loop through chain.

| Quad Module Route A | |
|---------------------|---------------|
| Switch 1 | External Loop |
| Switch 2 | External Loop |
| Switch 3 | External Loop |
| Switch 4 | External Loop |
| Internal Loop | Digital 1 |
| External Loop | Digital 2 |

| Quad Module Route B | |
|---------------------|---------------|
| Switch 1 | External Loop |
| Switch 2 | External Loop |
| Switch 3 | External Loop |
| Switch 4 | External Loop |
| Internal Loop | Digital 3 |
| External Loop | Digital 3 |

| Quad Module Route C | |
|---------------------|---------------|
| Switch 1 | External Loop |
| Switch 2 | External Loop |
| Switch 3 | External Loop |
| Switch 4 | External Loop |
| Internal Loop | Digital 1 |
| External Loop | DPort In |

| Quad Module Route D | |
|---------------------|---------------|
| Switch 1 | External Loop |
| Switch 2 | External Loop |
| Switch 3 | External Loop |
| Switch 4 | External Loop |
| Internal Loop | Digital 1 |
| External Loop | DPort In |

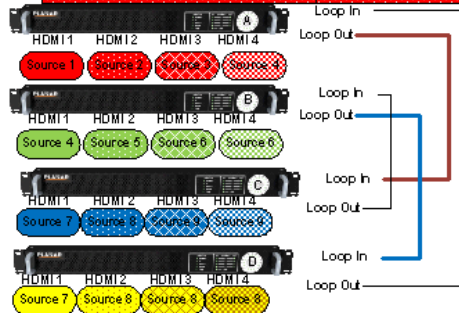
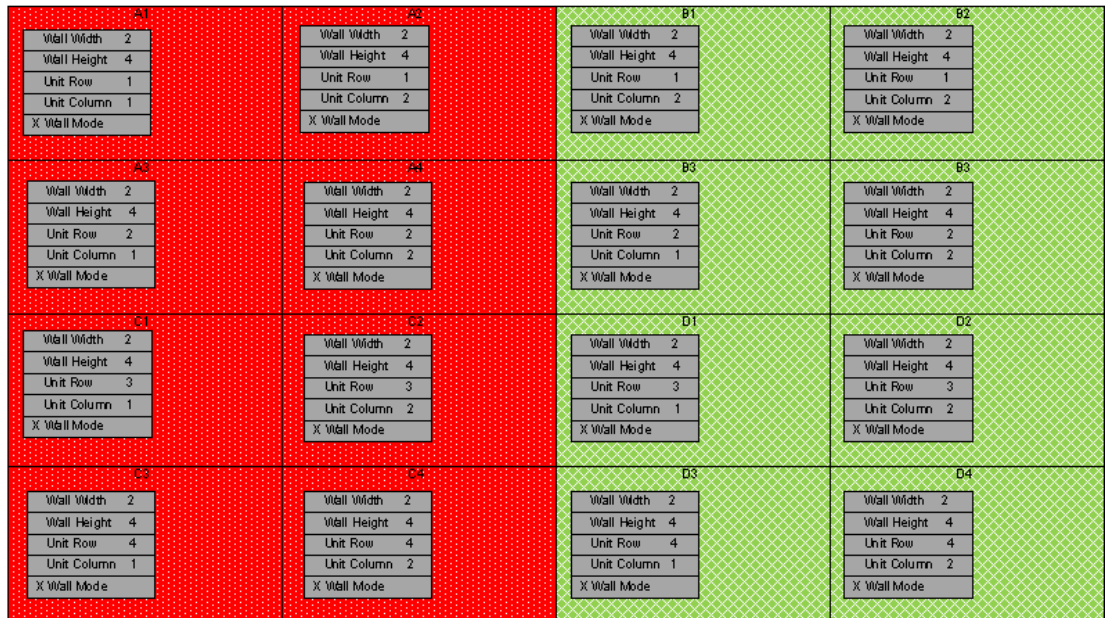

Note the cabling difference. A must loop out to C. B must loop out to D. Any source from A can be spread on the left half. Any source from B can be spread on the right half.

4 x 4 Matrix with two 4 x 2 sub walls. One Big Picture is also available, but each sub wall is limited to four sources.

Scenario 11: Multiple Large Sub Walls and NO Big Picture

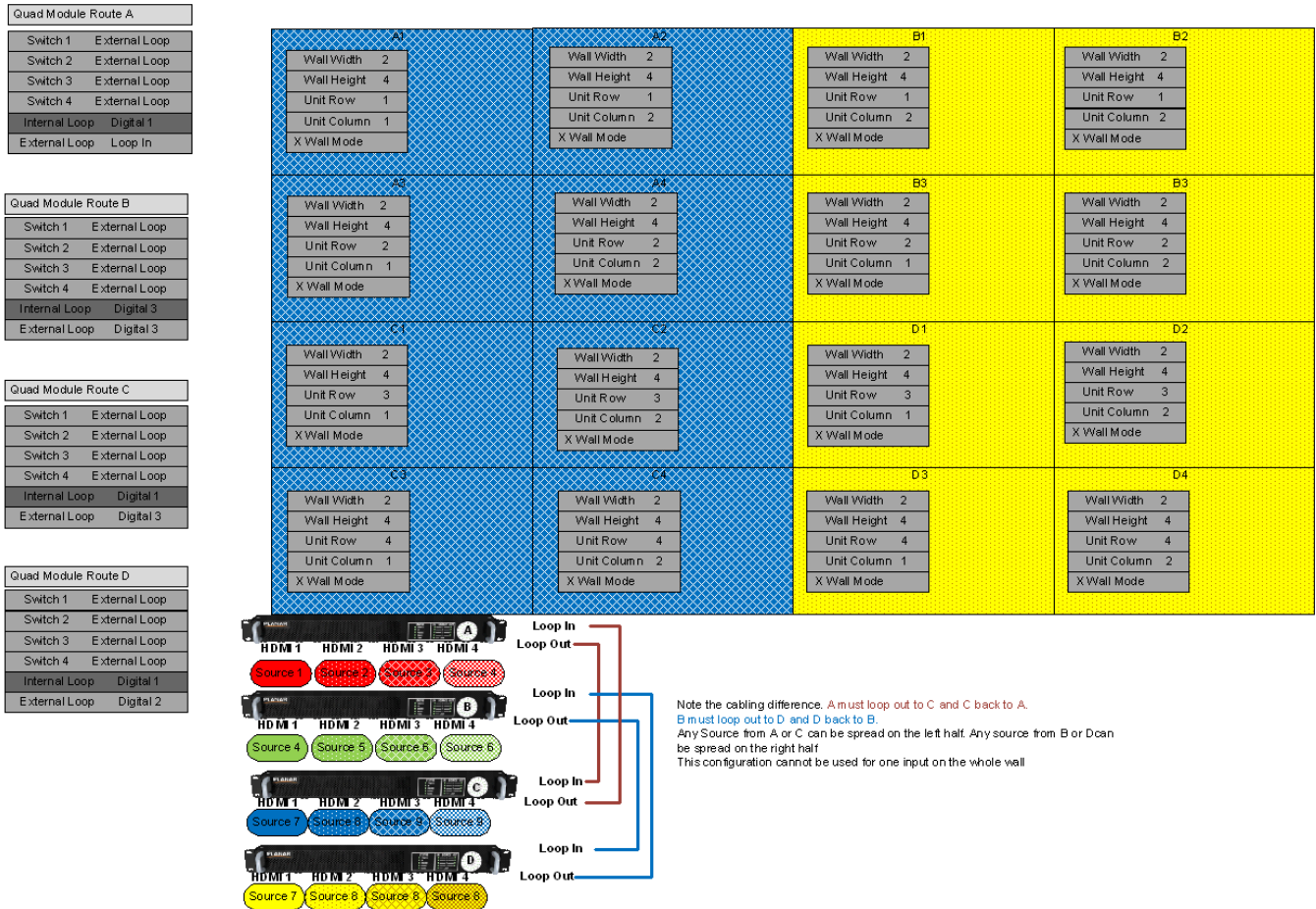

Matrix with two 4 x 2 sub walls. One Big Picture is **not** available, but each sub wall can have eight different sources.

Cabling Cluster the displays into the groups where you want your sub walls, and cable each sub wall to Quad controller module that are sequentially looped together. If you want to be able to also spread an input across the whole wall (Scenario 2), you must complete a single loop.

If you want to be able to spread more inputs across the sub wall than will fit on one Quad controller module, you can split the wall into separate loops.

Source Routing For each display that is part of a large sub wall, set each switch to Loop and External.

Set the External Loop of the Quad controller module that contains the source for a large sub wall to that source. Set the External Loop of all the other Quad controller modules to DPort In. Note that the source for the sub wall must be in the first Quad controller module unless you have looped the sub wall back on itself.

Wall Settings Set the height and width for each display within a sub wall to the height and width of that sub wall and set the unit row and unit column as appropriate.

Understanding the Quad Module Route Menu

Each Quad controller module has five digital video inputs: inputs 1-4 and a Dual Link loop input. Each module has four LCD connections and a Digital Loop Out DVI connector. Within each Quad controller module is a set of electronic switches that allow video to flow from one of the inputs to one of the LCDs and to the Digital Loop Out connector. The example below shows a pictorial representation of these switches. Each circle in the drawing represents one switch. For each switch, you can choose one of the input arrows to flow to the output of that switch, which in turn may flow to another switch or to one of the Quad controller module outputs.

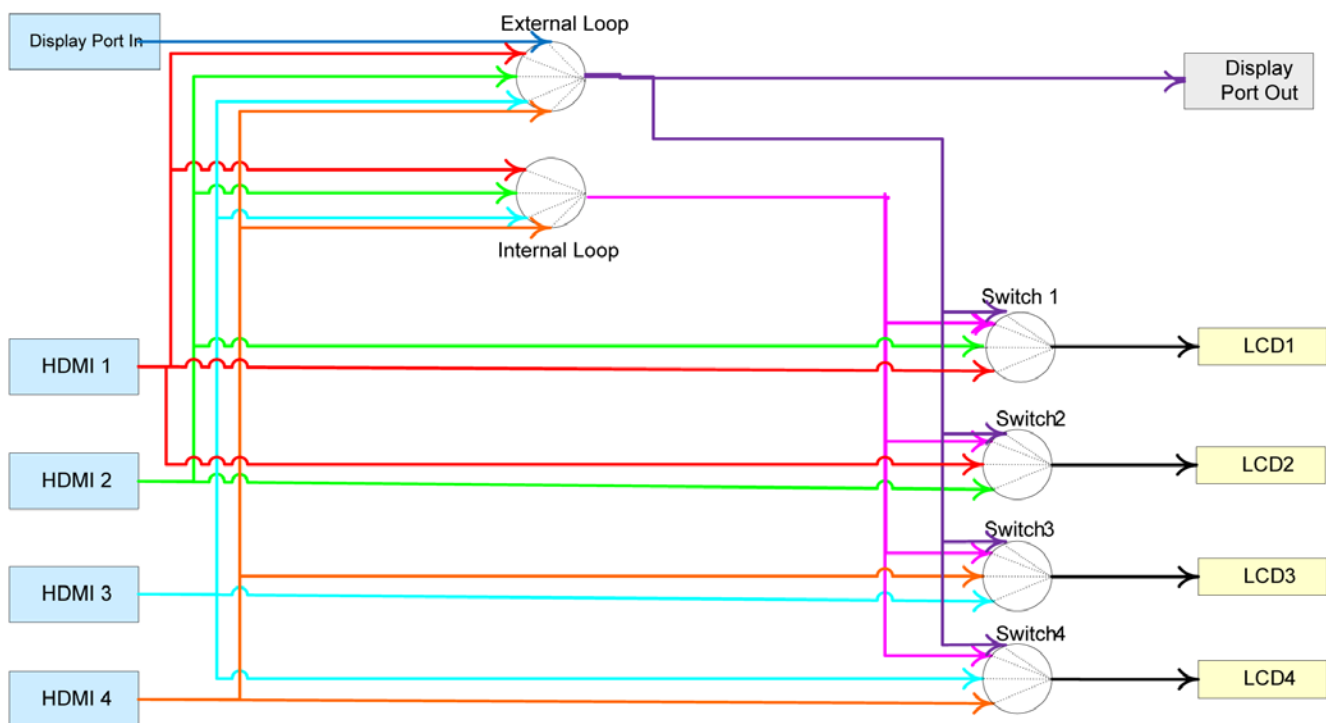

Representation of the Quad controller module video switches.

Keep the following points in mind:

- An LCD can display its own input, its immediate neighbor, or what is on either of the "loops."
- The Loop Out connector always displays what is on the external loop.
- The internal loop can display any of the HDMI connections, but not the DisplayPort connection.
- If you want to display what is on the Loop In connection, you must use the external loop, and it will also be on the Loop Out connector.

The QUAD MODULE ROUTE menu allows you to set these switches. There is one QUAD MODULE ROUTE menu for each Quad controller module in your system. There are two parts to the menu. Each part gives the same information in a different way. The top part of the menu shows you what input (1,2,3,4 or Link In) will be shown on each output (LCD 1, LCD 2, LCD 3, LCD 4 and Loop Out).

The bottom part of the menu shows you how each of the seven switches are set. You can change the switches using either part of the menu. The other part will automatically update. It may be frustrating to try to make changes in the switches using the top part of the menu, because not every combination of input to output is allowed. Changing one line on the top may cause changes in other lines. On the other hand, using the bottom part of the menu sets the switches directly so there are no disallowed states. As you set the switches on the bottom part of the menu, the top part of the menu will change to show the effect of your changes.

All of the scenarios in this section use only the bottom part of the menu to set up source routing.

| Quad Module Route A | | | | | |
|---------------------|--------------------------|--------------------------|-------------------------------------|-------------------------------------|--------------------------|
| | 1 | 2 | 3 | 4 | Link In |
| LCD 1 | <input type="checkbox"/> | <input type="checkbox"/> | <input checked="" type="checkbox"/> | <input type="checkbox"/> | <input type="checkbox"/> |
| LCD 2 | <input type="checkbox"/> | <input type="checkbox"/> | <input checked="" type="checkbox"/> | <input type="checkbox"/> | <input type="checkbox"/> |
| LCD 3 | <input type="checkbox"/> | <input type="checkbox"/> | <input checked="" type="checkbox"/> | <input type="checkbox"/> | <input type="checkbox"/> |
| LCD 4 | <input type="checkbox"/> | <input type="checkbox"/> | <input checked="" type="checkbox"/> | <input type="checkbox"/> | <input type="checkbox"/> |
| Loop Out | <input type="checkbox"/> | <input type="checkbox"/> | <input type="checkbox"/> | <input checked="" type="checkbox"/> | <input type="checkbox"/> |
| <hr/> | | | | | |
| Switch 1 | | | | | Internal Loop |
| Switch 2 | | | | | Internal Loop |
| Switch 3 | | | | | Internal Loop |
| Switch 4 | | | | | Internal Loop |
| Internal Loop | | | | | Digital 3 |
| External Loop | | | | | Digital 4 |

Configuring High Resolution Inputs

High resolution inputs are any inputs to the Clarity Matrix Video Wall that have a pixel clock greater than 165MHz, have a horizontal resolution greater than 2045 pixels or a vertical resolution greater than 2047 pixels. Such inputs are supported in Clarity Matrix but have limitations and restrictions as described in this section.

Hardware Limitation

The Image Processing chip used in the Matrix design has an input limitation of 165Mhz pixel clock and 2047 pixel horizontal or vertical resolution. However, be aware that the Matrix is a system of multiple chips each supporting a separate LCD display, we can still display such resolutions by spreading that image over more than one display in the system. We just need to provide the with the correct portion of the image for display. This is accomplished through front-end FPGA (field programmable gate array) logic in the Quad controller module and communication amongst the processors via the RS485 link.

High Resolution Setup

| Wall Configuration | PLANAR |
|--------------------------------|---------------|
| Quick Configure Big Picture A3 | Big Picture ▶ |
| Big Picture Setup | ▶ |
| Matrix Layout | ▶ |
| Quad Module A Route | ▶ |
| Quad Module B Route | ▶ |
| Quad Module C Route | ▶ |
| Synchronize High Resolutions | |

A high resolution input must use the Clarity Big Picture capability, either spreading the picture across the entire wall of displays or across some subset of displays, but it must be more than one. If a high resolution input is received and wall mode is not enabled, you will see only half of the image. In this case the message “Image truncated – Must use Big Picture” will appear on the BIG PICTURE SETUP menu and also on the UNIT STATUS menu.

Cabling for High Resolution

The DisplayPort Loop In of the Quad Controller module is also the input used to loop signals from one Quad Controller to the next. The DisplayPort connection is the only one that can handle high speed (pixel clock greater than 165MHz) signals. That means that only one high speed source can be used when enabling the Planar's Big Picture™.

Note: Be sure you are using DisplayPort cables.

Connect the signal to any of the Quad Controller modules and cable the Loop Out of that controller to the Loop In of the next controller, and so on. The Loop Out connection of the last Quad Controller will remain unconnected.

Multiple DisplayPort sources may be used in the system if each one is connected to a different Quad Controller. A typical application for this would be a system with an external video processor. By using one high resolution output of the processor per Quad Controller, the overall number of processor outputs needed will be reduced. In this situation, no loop through cables are needed.

Configuring a New High Resolution Input

When a new signal is acquired or the Big Picture setup has changed, the processors must communicate various information to each other. Because of limitations in the RS485 link, this communication can take several seconds to occur. During this time, the image on the wall may not be scaled correctly. You will see each display pop into place as the RS485 communication completes. Once you have made a change, you can speed up this period of resynchronization by pressing ENTER on the SYNCHRONIZE HIGH RESOLUTIONS line in the WALL CONFIGURATION menu. Be aware that the same processing must happen when switching to a low resolution input after displaying a high resolution input, and this control may be used in that case as well.

When using the quick configure option, the system will synchronize automatically. When a configuration is saved in a slot, the necessary information about high resolution inputs is saved as well. Once a configuration is set up, the easiest way to return to that configuration later is to recall it from a slot (see "Saving Configurations" on page 113). You must have the input in place at the connector before recalling the slot.

Handling Vertical Resolutions Greater Than 2047 Pixels

The processing chip has a 2047 line limitation in detecting a video source. If it gets a source that is greater than 2047 lines, the reported line total is the actual total minus 2048. The firmware works around this limitation by making educated guesses about the true total. Since the majority of applications will want to display native resolution on the Clarity Matrix, the firmware specifically looks for input resolutions that are multiples of native resolution. So, if it sees a reported input resolution of 1366 x 256, it will assume that the actual input resolution is 1366 x 2304 (a 1x3 column of native resolution). Similarly, it will assume 1366 x 1024 is actually 1366 x 3072. The only resolutions that have a vertical line count greater than 2047 are those that are multiples of potential native resolutions: 1366 x 768 or 1920 x 1080.

Supported Resolution Summary

| | |
|---|--|
| Up to 2045 pixels horizontal 400 to 2047 pixels vertical Pixel clock less than 165MHz | Supported on all inputs |
| 2046 to 4097 pixels horizontally 2048 to 2448 pixels vertically Pixel clock less than 165MHz | <ul style="list-style-type: none"> Supported on all inputs. Big Picture (Wall mode) must be selected to spread image over more than one display horizontally. System will take several seconds to scale correctly. |
| Up to 2045 pixels horizontal 2048 to 2448 lines vertically Pixel clock less than 165MHz | <ul style="list-style-type: none"> Supported on all inputs. Big Picture (Wall mode) must be selected to spread image over more than one display horizontally System will take several seconds to scale correctly. |
| 2046 to 4096 pixels horizontally 2048 to 2448 lines vertically Pixel clock less than 165MHz | <ul style="list-style-type: none"> Supported on all inputs. Big Picture (Wall mode) must be selected to spread image over more than one display horizontally. System will take several seconds to scale correctly. |
| Up to 4096 pixels horizontally 400 to 2047 lines vertically Pixel clock greater than 165MHz and less than 330MHz | <ul style="list-style-type: none"> Supported only on Dual Link (Display Port) Input. Big Picture (Wall mode) must be selected to spread image over more than one display horizontally. Note: Even if the horizontal resolution is less than 1920, it still must be spread horizontally. Therefore, 1920x2160 @60Hz Cannot be displayed 1:1. System will take several seconds to scale correctly |
| Up to 4096 pixels horizontally 2048 to 2448 lines vertically Pixel clock greater than 165MHz and less than 330MHz | <ul style="list-style-type: none"> Supported only on Dual Link (Display Port) Input. Big Picture (Wall mode) must be selected to spread image over more than one display horizontally and vertically. System will take several seconds to scale correctly. |

The table below lists some of the commonly used Planar's Big Picture™ resolutions and shows the maximum refresh rate allowed to stay within the limits for HDMI and DisplayPort connections.

Commonly Used Big Picture resolutions

| Big Picture Size | Resolution | Maximum for HDMI | Maximum for DisplayPort |
|------------------|-------------|------------------|-------------------------|
| 1 x 2 | 1920 x 2160 | 30Hz | 30Hz |
| | 1366 x 1536 | 60Hz | 60Hz |
| 1 x 3 | 1920 x 3240 | 24Hz | 24Hz |
| | 1366 x 2304 | 50Hz | 50Hz |
| | 960 x 3240 | 48Hz | 48Hz |
| 1 x 4 | 1366 x 3072 | 30Hz | 30Hz |
| | 960 x 2160 | 60Hz | 60Hz |
| 2 x 1 | 3840 x 1080 | 30Hz | 60Hz |
| | 2732 x 768 | 60Hz | 60Hz |
| | 1920 x 540 | 60Hz | 60Hz |
| 2 x 2 | 3840 x 2160 | 30Hz | 60Hz |
| | 2732 1536 | 30Hz | 60Hz |
| 2 x 3 | 2732 x 2304 | 24Hz | 30Hz |
| 2 x 4 | 2732 x 3072 | 16Hz | 30Hz |
| 3 x 1 | 4096 x 768 | 50Hz | 60Hz |
| | 2880 x 540 | 60Hz | 60Hz |
| 4 x 1 | 3840 x 540 | 60Hz | 60Hz |

On-Screen Menus

If you are viewing this as a PDF, you can click on an active line in a menu and go to the submenu. Active lines are the ones with arrows. You can also click on the heading of a menu and go back to its parent menu.



- Solid black arrows ► lead to navigational menus.
- Hollow blue arrows > lead to status menus.
- Hollow green arrows ▷ lead to slave menus.

| Main Menu | PLANAR |
|---------------------|--------|
| Wall Configuration | ► |
| Picture | ► |
| Memory | ► |
| Diagnostics | ► |
| Advanced Options | ► |
| Program Information | > |

| Program Information | PLANAR |
|--|-------------------------------------|
| Planar Systems, Inc. | |
| Control Room & Digital Signage Division | |
| 1195 NW Compton Drive | |
| Beaverton, OR 97006-1992 USA | |
| +1.866.475.2627 | |
| +503.748.1100 | |
| www.planar.com | |
| Matrix | 1920 x 1080 |
| 010-1409 | Rev 01 |
| Code Generated Date: | Oct 24 2013 at 13:Q44:10 |
| LCD Interface: | 1456-01:Oct 01 2013 17:55:09 |
| Valens: V5010TX | 10200523 2013-2-17 |
| VS100RX | 00200513 2013-2-17 |





| Wall Configuration | | PLANAR |
|-------------------------------------|-----------------------|---------------|
| Set up whole wall | | |
| Quick Configure Big Picture | Big Picture A1 | ▶ |
| Big Picture Setup | | ▶ |
| Matrix Layout | | ▶ |
| Quad Module A Route | | ▶ |
| Quad Module B Route | | ▶ |
| Quad Module C Route | | ▶ |
| Synchronize High Resolutions | | |

| Quick Configure | | | | PLANAR | | | |
|-------------------------------|-----------|-----------|-----------|---------------|-----------|-----------|-----------|
| Spread input over entire wall | | | | | | | |
| A1 | A2 | A3 | A4 | B1 | B2 | B3 | B4 |
| C1 | C2 | C3 | C4 | | | | |
| | | | | | | | |
| | | | | | | | |
| | | | | | | | |
| | | | | | | | |
| | | | | | | | |
| | | | | | | | |
| Dp | | | | | | | |
| Quad 1 | Quad 2 | Quad 3 | Quad 4 | 1 & 3 | Dp | | No BP |

| Big Picture Setup | | PLANAR |
|---|---------------------------|------------------|
| Matrix Position | 3x3 | 1:1 |
| Wall Width | | 3 |
| Wall Height | | 3 |
| Unit Column | | 1 |
| Unit Row | | 1 |
| <input type="checkbox"/> | Wall Mode | |
| <input type="checkbox"/> | Frame Compensation | |
|  | Frame Height | 10 pixels |
|  | Frame Width | 10 pixels |
| <input type="checkbox"/> | Frame Compensation | |
| * *** Copy Settings to All Displays | | |

| Picture | PLANAR |
|-----------------------|--------|
| Set Colorspace/Levels | |
| Picture Information | > |
| Picture Setup | > |
| Aspect Ratio | > |

| Picture Information | PLANAR |
|-----------------------|-------------|
| Sync | Progressive |
| Vertical Frequency | 60Hz |
| Horizontal Frequency | 50.00kHz |
| Pixel Frequency | 80.10MHz |
| Horizontal Resolution | 1920 |
| Vertical Resolution | 1080 |
| 8bpc | |

| Picture Setup | PLANAR | | |
|--|--------------------------------------|-----|-----|
|  Colorspace | RGB | | |
| Center Point | 255 | 255 | 255 |
|  Black Level (offset) - All | - [Slider] + | | |
| Red | - [Slider] + 128 | | |
| Green | - [Slider] + 128 | | |
| Blue | - [Slider] + 128 | | |
|  White Level (gain) -All | - [Slider] + 132 | | |
| Red | - [Slider] + 120 | | |
| Green | - [Slider] + 154 | | |
| Blue | - [Slider] + 122 | | |
|  Set to Nominal for RGB Levels (0-255) | | | |
| * *** | Copy Settings to All Displays | | |

| Aspect Ratio | PLANAR | |
|--|--------------------------------------|---|
| <input checked="" type="checkbox"/> Scale Mode | 16 x 9 | |
| Justify | Center | |
| Overscan | 0% | |
|  Sharpness | - [Slider] + | 4 |
| * *** | Copy Settings to All Displays | |

| Memory | PLANAR |
|--------|--------|
| Recall | ▶ |
| Save | ▶ |
| Delete | ▶ |

| Recall | PLANAR | | | | | | | | |
|-------------------------------------|--------|-------------------------------------|----|-------------------------------------|----|--------------------------|----|--------------------------|----|
| <input checked="" type="checkbox"/> | 1 | <input checked="" type="checkbox"/> | 9 | <input checked="" type="checkbox"/> | 17 | <input type="checkbox"/> | 25 | <input type="checkbox"/> | 33 |
| <input checked="" type="checkbox"/> | 2 | <input checked="" type="checkbox"/> | 10 | <input type="checkbox"/> | 18 | <input type="checkbox"/> | 26 | <input type="checkbox"/> | 34 |
| <input type="checkbox"/> | 3 | <input checked="" type="checkbox"/> | 11 | <input type="checkbox"/> | 19 | <input type="checkbox"/> | 27 | <input type="checkbox"/> | 35 |
| <input type="checkbox"/> | 4 | <input type="checkbox"/> | 12 | <input type="checkbox"/> | 20 | <input type="checkbox"/> | 28 | <input type="checkbox"/> | 36 |
| <input type="checkbox"/> | 5 | <input type="checkbox"/> | 13 | <input type="checkbox"/> | 21 | <input type="checkbox"/> | 29 | <input type="checkbox"/> | 37 |
| <input type="checkbox"/> | 6 | <input type="checkbox"/> | 14 | <input type="checkbox"/> | 22 | <input type="checkbox"/> | 30 | <input type="checkbox"/> | 38 |
| <input type="checkbox"/> | 7 | <input type="checkbox"/> | 15 | <input type="checkbox"/> | 23 | <input type="checkbox"/> | 31 | <input type="checkbox"/> | 39 |
| <input type="checkbox"/> | 8 | <input type="checkbox"/> | 16 | <input type="checkbox"/> | 24 | <input type="checkbox"/> | 32 | <input type="checkbox"/> | 40 |

| Save | PLANAR | | | | | | | | |
|--------------------------|--------|--------------------------|----|--------------------------|----|--------------------------|----|--------------------------|----|
| <input type="checkbox"/> | 1 | <input type="checkbox"/> | 9 | <input type="checkbox"/> | 17 | <input type="checkbox"/> | 25 | <input type="checkbox"/> | 33 |
| <input type="checkbox"/> | 2 | <input type="checkbox"/> | 10 | <input type="checkbox"/> | 18 | <input type="checkbox"/> | 26 | <input type="checkbox"/> | 34 |
| <input type="checkbox"/> | 3 | <input type="checkbox"/> | 11 | <input type="checkbox"/> | 19 | <input type="checkbox"/> | 27 | <input type="checkbox"/> | 35 |
| <input type="checkbox"/> | 4 | <input type="checkbox"/> | 12 | <input type="checkbox"/> | 20 | <input type="checkbox"/> | 28 | <input type="checkbox"/> | 36 |
| <input type="checkbox"/> | 5 | <input type="checkbox"/> | 13 | <input type="checkbox"/> | 21 | <input type="checkbox"/> | 29 | <input type="checkbox"/> | 37 |
| <input type="checkbox"/> | 6 | <input type="checkbox"/> | 14 | <input type="checkbox"/> | 22 | <input type="checkbox"/> | 30 | <input type="checkbox"/> | 38 |
| <input type="checkbox"/> | 7 | <input type="checkbox"/> | 15 | <input type="checkbox"/> | 23 | <input type="checkbox"/> | 31 | <input type="checkbox"/> | 39 |
| <input type="checkbox"/> | 8 | <input type="checkbox"/> | 16 | <input type="checkbox"/> | 24 | <input type="checkbox"/> | 32 | <input type="checkbox"/> | 40 |























| Delete | PLANAR | | | | | | | | |
|-------------------------------------|--------|-------------------------------------|----|-------------------------------------|----|--------------------------|----|--------------------------|----|
| <input checked="" type="checkbox"/> | 1 | <input checked="" type="checkbox"/> | 9 | <input checked="" type="checkbox"/> | 17 | <input type="checkbox"/> | 25 | <input type="checkbox"/> | 33 |
| <input checked="" type="checkbox"/> | 2 | <input checked="" type="checkbox"/> | 10 | <input type="checkbox"/> | 18 | <input type="checkbox"/> | 26 | <input type="checkbox"/> | 34 |
| <input type="checkbox"/> | 3 | <input checked="" type="checkbox"/> | 11 | <input type="checkbox"/> | 19 | <input type="checkbox"/> | 27 | <input type="checkbox"/> | 35 |
| <input type="checkbox"/> | 4 | <input type="checkbox"/> | 12 | <input type="checkbox"/> | 20 | <input type="checkbox"/> | 28 | <input type="checkbox"/> | 36 |
| <input type="checkbox"/> | 5 | <input type="checkbox"/> | 13 | <input type="checkbox"/> | 21 | <input type="checkbox"/> | 29 | <input type="checkbox"/> | 37 |
| <input type="checkbox"/> | 6 | <input type="checkbox"/> | 14 | <input type="checkbox"/> | 22 | <input type="checkbox"/> | 30 | <input type="checkbox"/> | 38 |
| <input type="checkbox"/> | 7 | <input type="checkbox"/> | 15 | <input type="checkbox"/> | 23 | <input type="checkbox"/> | 31 | <input type="checkbox"/> | 39 |
| <input type="checkbox"/> | 8 | <input type="checkbox"/> | 16 | <input type="checkbox"/> | 24 | <input type="checkbox"/> | 32 | <input type="checkbox"/> | 40 |







| Diagnostics | PLANAR |
|--------------------|--------|
| Unit Status | > |
| Serial Port Status | > |
| Test Patterns | > |
| Setup Summary | > |
| Hours | > |
| Networking | ▶ |

| Unit Status A1 | PLANAR | | | |
|----------------|--------|-----------|-------------|--|
| Matrix | Rev 01 | | 1920 x 1080 | |
| 010-1409 | | | | |
| LCD | | | | |
| Temperature | 20 °C | Backlight | OK | |
| 24v Supply | 24.40v | | | |
| 48v Supply | 47.31v | | | |
| Power | 52.26w | MX46HDS | | |
| Quad Module | | | | |
| Temperature | 31 °C | Fan | OK | |
| Power Supplies | | | | |
| | | Fan | OK | |
| | | PS | OK | |

Note: The QUAD MODULE and POWER SUPPLIES lines only appear on processor number 1 of each Quad controller module.

| Serial Port Status RS485 | PLANAR |
|---|---------------|
| <ENTER> to clear; +/- to select different serial port | |
| Commands Received | 34 |
| Replies Sent | 34 |
| Last Packet Type | Operation |
| Last Packet Address | Not Addressed |
| Bytes Received | 921 |
| Bytes Sent | 773 |
| UART Framing Errors | 4 |
| UART Overflow Errors | 0 |
| Group A Unit: 1 | 19200 Baud |
| Most Recent | |
| ...115, 111, 108, 117, 105, 111, 110, 63, 13 | |
| .st--1?.st--2?.st--3?.lcd.vertical-resolution?. | |

| Test Patterns | | | | PLANAR | |
|--|---|---|--|--------|--|
| <ENTER> to select, None to show picture | | | | | |
|  None |  Red |  Red Scale |  Logo | | |
|  White |  Green |  Green Scale |  Grid | | |
|  Black |  Blue |  Blue Scale |  4x4 Contrast | | |
|  Gray |  Cyan |  Gray Scale |  Uniformity | | |
|  Custom Color |  Yellow |  Colors |  Focus | | |
| |  Magenta |  Color Bars | | | |

























| Setup Summary | | | | PLANAR | |
|--|--------------------|------|-------|--------|--|
| Current Setup Information | | | | | |
| Quad Module Route Code | 682 | 2048 | | | |
| Wall | 3 x 3 | 1:1 | | | |
| Scale/Justify | Fill Screen/Center | | | | |
| Position/Overscan | 100,100 | /0% | | | |
| Zoom UL/ LR | +0,+0 | / | +0,+0 | | |
| Viewport UL/LR | +0,+0 | / | +0,+0 | | |
|  Sharpness | 4 | | | | |
|  Black Level | 109 | 109 | 109 | | |
|  White Level | 149 | 149 | 149 | | |
|  Backlight Intensity | | | 20 | | |
|  White Balance | 100 | 100 | 100 | | |
|  Gray Balance | 7 | 7 | 7 | | |
|  Backlight Adjustment | | | +0 | | |

| Networking | | PLANAR | |
|--------------------------|-------------------|--------|--|
| 3.3 Mar 28 2014 15:55:44 | | | |
| IP Address | 192.168.12.12 | | |
| MAC Address | 00:80:A3A91A99AF2 | | |
| Reset to Factory | | | |

| Hours | | PLANAR | |
|---------------------------|----------|--------|--|
| System Time | 00636:45 | | |
| Backlight Time | 00532:00 | | |
| Average Hours Per Day | 12 | | |
| Number of Days > 20 Hours | 0 | | |

Note: The last two lines will only appear on the master (A1) display.

| Advanced Options | PLANAR |
|-----------------------------|--------|
| Color Balance | ▶ |
| Size and Position | ▶ |
| Miscellaneous Options | ▶ |
| Backlight Settings | ▶ |
| Serial Port Settings | ▶ |
| Set Clock / Schedule Events | ▶ |
| EDID | ▶ |
| Orbiter | ▶ |

| Color Balance | | PLANAR |
|---|---|---------------------|
| Color Temperature | | Native |
|  |  | White Test Pattern |
|  | White Balance - All (Clipboard) | |
| Red |  - <input type="text"/> +  | 100 (100) |
| Green |  - <input type="text"/> +  | 100 (100) |
| Blue |  - <input type="text"/> +  | 100 (100) |
|  |  | Gray Test Pattern |
|  | Gray Balance - All | |
| Red |  - <input type="text"/> +  | 7 (7) |
| Green |  - <input type="text"/> +  | 7 (7) |
| Blue |  - <input type="text"/> +  | 7 (7) |
|  | Backlight Adjustment +0 | |
|  | Copy to Clipboard | |
|  | Recall From Clipboard | |
|  | Reset to Native | |
|  | Reset to Factory | |
|  |  | Remove Test Pattern |

| Miscellaneous Options | | PLANAR |
|-------------------------------------|----------------------------|----------------|
| <input checked="" type="checkbox"/> | Menu Timeout | Never Time Out |
| | Rotate Menu | None |
| <input type="checkbox"/> | Hide Source Absent Message | |
| <input checked="" type="checkbox"/> | Allow Frame Lock | |
| | Frame Lock Type | Default |
| <input checked="" type="checkbox"/> | Allow 10 Bits Per Color | |
| | Native Frequency | 60Hz |

| Backlight Control | | PLANAR |
|-------------------------------------|---|--------|
| <input checked="" type="checkbox"/> | Auto Backlight on | |
| <input type="checkbox"/> | Turn Backlight Off When No Source (DPMS) | |
| | DPMS Delay | 1 hr |
| | Backlight Control Mode | Auto |
| | Backlight Intensity - <input type="range"/> + | 10 |
| | Dimmed Intensity | 20 |
| | Ambient Threshold | 25 |
| | Ambient Light | |

For Auto Mode

For Manual Mode

| Backlight Control | | PLANAR |
|-------------------------------------|---|--------|
| <input checked="" type="checkbox"/> | Auto Backlight on | |
| <input type="checkbox"/> | Turn Backlight Off When No Source (DPMS) | |
| | DPMS Delay | 1 hr |
| | Backlight Control Mode | Manual |
| | Backlight Intensity - <input type="range"/> + | 10 |

| Serial Port Settings | | PLANAR |
|----------------------|---------------------------|----------|
| | ASCII Response Type | Symbolic |
| | ASCII Response Terminator | CR |
| | Baud Rate | 19200 |

Set Clock / Schedule Events

PLANAR

Press <ENTER> to set clock and schedule events

| | | | | | | |
|---------|------------|-----------------|------|----|------|------------|
| Current | Date/Time: | Mon | Feb | 28 | 2010 | 10:40 |
| 01 | 07:30 | Daily | | | | Turn On |
| 02 | 21:30 | Daily | | | | Turn Off |
| 03 | 12:30 | Mondays | | | | Recall #04 |
| 04 | 16:00 | Wednes- days | | | | Recall #23 |
| 05 | 02:00 | Apr 1 | 2010 | | | Clk +1 Hr |
| 06 | 02:00 | Oct 28 | 2010 | | | Clk -1 Hr |
| 07 | | | | | | |
| 08 | | | | | | |
| 09 | | | | | | |
| 10 | | | | | | |
| 11 | | | | | | |
| 12 | | | | | | |
| 13 | | | | | | |
| 14 | | | | | | |
| 15 | | | | | | |
| 16 | | | | | | |
| 17 | | | | | | |
| 18 | | | | | | |
| 19 | | | | | | |
| 20 | | | | | | |

EDID

PLANAR

EDID Detailed Timing 1 (Preferred Timing) ▶

EDID Detailed Timing 2 ▶

EDID Has Only Preferred Timing

EDID (Plug and Play) Enabled

Orbiter

PLANAR

Orbiter Enabled

Time Interval 1 Minutes

Shift Size 4 Pixels

| EDID Detailed Timing 1 | | PLANAR |
|--|-----------|--------|
| Number of pixels per line | | |
| Update EDID | | |
| Horizontal Active | 1920 | |
| Vertical Active | 1080 | |
| Vertical Refresh Rate | 60Hz | |
| <input type="checkbox"/> Fully Specified | | |
| Pixel Clock | 148.50MHz | |
| Horizontal Blanking | 280 | |
| Horizontal Front | 88 | |
| Horizontal Sync Width | 45 | |
| Vertical Blanking | 45 | |
| Vertical Front Porch | 4 | |
| Vertical Sync Width | 5 | |
| Revert to Factory | | |

| EDID Detailed Timing 2 | | PLANAR |
|--|----------|--------|
| Number of pixels per line | | |
| Update EDID | | |
| Horizontal Active | 3840 | |
| Vertical Active | 2160 | |
| Vertical Refresh Rate | 30Hz | |
| <input type="checkbox"/> Fully Specified | | |
| Pixel Clock | 247.0MHz | |
| Horizontal Blanking | 560 | |
| Horizontal Front | 60 | |
| Horizontal Sync Width | 100 | |
| Vertical Blanking | 90 | |
| Vertical Front Porch | 2 | |
| Vertical Sync Width | 4 | |
| Revert to Factory | | |

In the **EDID Detailed Timing** menus, when the **Fully Specified** box is checked, all the items below it become active.

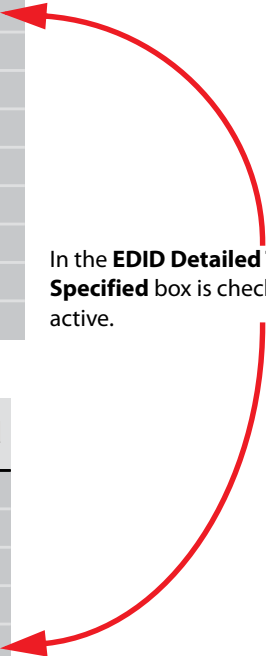

| Size & Position | | PLANAR |
|---------------------------------|--|--------|
| Picture Position | | ▷ |
| Zoom Window Top & Left | | ▷ |
| Zoom Window Bottom & Right | | ▷ |
| Viewport Window Top & Left | | ▷ |
| Viewport Window Bottom & Right | | ▷ |
| Reset All Windows to Default | | |
| * Copy Settings to All Displays | | |
| *** | | |

| Picture Position | | PLANAR |
|---|--|--------|
| Use arrow keys to move image | | |
|  | | |
| Horizontal Position | | 100 |
| Vertical Position | | 100 |

Zoom Top & Left PLANAR

Arrows move top and left

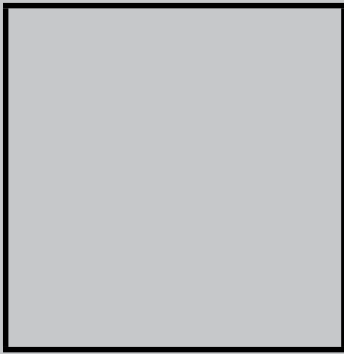

Image Resolution 1920 x 1080
This Unit 960 x 540

Zoom Bottom & Right PLANAR

Arrows move bottom and right





Image Resolution 1920 x 1080
This Unit 960 x 540

Viewport Top & Left PLANAR

Arrows move top and left



Display Resolution 1920 x 1080
Viewport 1920 x 1080

Viewport Bottom & Right PLANAR

Arrows move bottom and right



Display Resolution 1920 x 1080
Viewport 1920 x 1080

Troubleshooting

Below is a troubleshooting table of some common issues you might encounter when installing or running your Clarity Matrix Video Wall.

| What to look for | If you see it | If you don't see it |
|--|--|--|
| Blinking Green LED next to Video connection on the LCD interface board | Video connection is good. | Check power and video connections to the LCD and Quad controller module. |
| Power LED on front panel is green. One address LED is lit | Front panel is connected and working properly. Power is good to the Quad controller module. | Check power to Quad controller module. If you see more than one address LED lit (the ones on the circle) the system is doing an automatic update. Wait up to 20 minutes for it to complete. Do not turn off power during this time. |
| Blinking RS485 light on all Quad controller modules except A | RS485 connections are good. | You must have one and only one 'A' Quad controller module. |
| Green LED in Out Column for the LCD | Video connection to LCD is good. 'A' Quad controller module is powered on and cabled to this one via RS485. All Quad controller modules have unique addresses. | If the LED is red, there is communication to the LCD interface, but it is not receiving video. This may indicate a malfunctioning LCD interface or Quad Controller. It can take up to a minute for this LED to reflect the state of the system—you may need to wait if you have just turned on or changed connections. |

| | | |
|---|--|--|
| <p>All LCD backlights turn on with IR remote</p> | <p>IR sensor is connected.</p> <p>Quad controller module A is configured and cabled to the other Quad controller modules.</p> <p>Video connection to LCDs is good.</p> | <p>IR sensor must be plugged in to 'A' Quad controller module or to A1 LCD interface module.</p> <p>Quad controller modules must be cabled together via RS485.</p> <p>There must be one and only one 'A' Quad controller module.</p> <p>If a Quad controller module has been newly connected, you may have to turn off and then back on to synchronize those displays. If in doubt, A/C power cycle the system after all connections have been made.</p> |
| <p>"Info Pane" appears on all displays when menus are on. (The "info pane" is the gray square which shows the display address, position sensor information and information about the target menu)</p> | <p>Video connection is good.</p> | <p>If some displays do not respond, you may have out of date firmware. All Quad controller modules must have the same revision level of firmware.</p> |
| <p>Unit Status Menu appears on all displays when the MONITOR button is pressed</p> | | <p>If a different menu appears on some displays, you may have mismatched firmware. All Quad controller modules must have the same revision level of firmware, and that firmware must be "cloned" to all 4 of the processors.</p> |
| <p>Unit Status Menu -</p> <p>Temperature is within reason</p> <p>Backlight shows OK</p> <p>Voltage is >22V</p> | <p>The LCD and its interface board are functioning properly.</p> | <p>These three items are reported to the Quad controller module by the LCD interface board over the Comm connection. If the voltage is 0 the voltage meter is not functioning on the LCD interface board (some early prototype systems did not have this meter). If the voltage is low, there may be too much drop in your power cables.</p> |

| | | |
|--|---|---|
| <p>Unit Status Menu - Quad Module Temperature is within reason and Fan is OK</p> | <p>The Quad controller module cooling system is operating normally.</p> | <p>This portion of the menu only shows up on processor 1 of a Quad controller module. Check for proper fan function and proper cooling of the rack.</p> |
| <p>Unit Status Menu - Power Supply shows OK and power supply fan is OK</p> | <p>The power supply that are connected together are operating normally.</p> | <p>This portion of the menu only shows up on processor A1. If the message "PS Mon cable is not connected" shows in this menu, there is no power supply monitor cable connected. To be sensed, all power supplies in the system must be chained together via PS Mon cables and connected to the PS Mon connection on Quad Controller A.</p> |
| <p>Matrix Layout - Auto completes correctly</p> | <p>Position Sensors are aligned and working correctly.</p> | <p>Look at the info pane of each display. It shows you its position as reported by the LCD interface board. These numbers update about once a second.</p> <p>An LCD in service mode will not report the correct position.</p> <p>If a display on the top row shows a row other than 1 or a display on the left side shows a column other than 1, then light energy is causing a false reading. This can happen with some fluorescent lights. Cover the position sensor hole from receiving light.</p> <p>Each row should show columns in order from left to right. If the column number starts again at 1, there is a problem either with the receiver of that display or the transmitter of the display next to it.</p> <p>Check for proper alignment of the displays. Similarly, each column should show row numbers in order from top to bottom.</p> |

| | | |
|--|--|---|
| <p>< > buttons on the IR remote move a slave menu sequentially to each display in the Matrix</p> | <p>Auto Layout has been performed.</p> | <p>If Auto Layout has not been completed or had errors, the menu will appear on each display in address order (A1, A2, A3). If no display is connected for a particular address, the menu will “disappear”. Press the arrow key again to move it to the next one until it comes back. You can see which display is being addressed by watching the info pane on any display. Once auto layout has completed, Quad controller modules that are not connected will be ignored. Even if the position sensors are not working, it will be helpful to attempt auto layout.</p> |
| <p>Solid Green DC CK LED on the front of the power supply module for each one installed</p> | <p>Power module is supplying +48V VDC.</p> | <p>If LED is blank, that power supply module is not installed. If LED is red, that power supply module is faulty.</p> |
| <p>Flashing lights at the power meter</p> | <p>Remove some of the load from the power supply</p> | <p>Green and amber lights indicate a properly working system. No lights indicate no load applied.</p> |

Common Symptoms and How to Troubleshoot Them

The following section gives you a step by step process to troubleshoot common issues, such as the screen is black. In the examples below, B2 is the display in question. References to this display are in red below. For specific troubleshooting, substitute the desired module and unit address for the display in question. All serial commands must be terminated with a carriage return or linefeed.

Symptom: Black Screen

| Question | How to find the answer | Possible actions to take |
|---|---|--|
| 1 Is the backlight on? | This takes a little practice to determine. Looking at the back of the array, you can see a bit of glow between the displays when the backlight is on. There is also a difference in the “blackness” of the black with the backlight on and off. Try turning the backlights off and back on to see if there is a difference. | <ul style="list-style-type: none"> • Check Power cable to the system. • Check power supply (question 10). • Turn backlight to system off and back on - the display may have become out of sync with the system. • The display may not be receiving commands. See question 5. |
| 2 Is communication reaching the display? | The LED next to the comm. RJ11 cable at the display should be blinking. The response to the command <code>OP B2 S?</code> should be negative (bit 15 is high). | <ul style="list-style-type: none"> • Check video connection • Swap video connection with a known good Quad Controller output. |
| 3 Are menus available at the display? | Press MENU on the remote, or send <code>KY ** MENU.</code> | <ul style="list-style-type: none"> • Swap comm and video cables with a known good Quad Controller output. |
| 4 Is it in the Source Absent state? | Bring up a menu (question 6). The Source Absent message will appear above the display's address. | <ul style="list-style-type: none"> • Check the routing (question 8). • Check the input cabling. • Check the source device. |
| 5 What are the routing settings? | Bring up the QUAD MODULE ROUTE B menu (MAIN MENU > WALL CONFIGURATION) and look for a check mark in the LCD 2 row under the desired input column. | <ul style="list-style-type: none"> • Select the correct switch settings in the menu until the desired source is routed to that output. |
| 6 Can the source be routed to other displays in the system? | Bring up the QUAD MODULE ROUTE B menu (MAIN MENU > WALL CONFIGURATION) and change the switch settings to route the same source to a known working display. | <ul style="list-style-type: none"> • If the source cannot be shown on another display, check the source device. |

| | | |
|---|--|--|
| <p>7 What is the state of the power supply?</p> | <p>Bring up the UNIT STATUS menu (MAIN MENU > DIAGNOSTICS) by pressing the MONITOR button and view the Power Supply states on display A1. Or, send the command op A1 QUAD.PS.STATUS. Note that this command should be sent to the Master A1.</p> | <ul style="list-style-type: none"> • Be sure there are enough supplies in the module to drive the desired number of displays. • Check for errors, failures, faults., see the box "If the Power Supply fan is Failed or shows Fault" on page 163. |
| <p>8 What is the Big Picture Setup?</p> | <p>Bring up the BIG PICTURE SETUP menu (MAIN MENU > WALL CONFIGURATION) or the SETUP SUMMARY menu (MAIN MENU > DIAGNOSTICS) or read the settings with the following commands: op B2 WALL.MODE? op B2 WALL.WIDTH? op B2 WALL.HEIGHT? op B2 WALL.ROW? op B2 WALL.COLUMN? op B2 WALL.STATUS?</p> | <ul style="list-style-type: none"> • The portion of the input video shown on this piece of a wall could be black. Turn wall mode off to view the entire image. • If WALL.STATUS is not 0, or the message "Can't display -- change Scale Mode--" appears on the menu, then the Big Picture scaler is not able to display the image at these settings. |
| <p>9 What are the zoom/viewport settings?</p> | <p>Bring up the SETUP SUMMARY menu (MAIN MENU > DIAGNOSTICS) or read the settings with the following commands: op B2 VIEWPORT.WINDOW.BOTTOM? op B2 VIEWPORT.WINDOW.LEFT? op B2 VIEWPORT.WINDOW.RIGHT? op B2 VIEWPORT.WINDOW.TOP? op B2 ZOOM.WINDOW.BOTTOM? op B2 ZOOM.WINDOW.LEFT? op B2 ZOOM.WINDOW.RIGHT? op B2 ZOOM.WINDOW.TOP?</p> <p>op B2 OVERSCAN? op B2 POSITION.VERTICAL? op B2 POSITION.HORIZONTAL?</p> | <ul style="list-style-type: none"> • Under normal circumstances, all zoom, viewport and overscan settings should be at 0. Position should be 100. Abnormal settings could prevent the picture from displaying properly. |

| | | |
|---|---|---|
| <p>10 What are the picture settings?</p> | <p>Bring up the SETUP SUMMARY menu (MAIN MENU > DIAGNOSTICS) and read the black level and white level settings or read the following settings with the following commands: op B2 OFFSET.RED? op B2 OFFSET.GREEN? op B2 OFFSET.BLUE? op B2 GAIN.RED? op B2 GAIN.GREEN? op B2 GAIN.BLUE?</p> | <ul style="list-style-type: none"> Under normal circumstances, the gains (white level) should be 128 or 149 and the offsets (black level) should be 128 or 109 Abnormal settings could prevent the image from displaying properly. |
| <p>11 Is a test pattern being viewed?</p> | <p>Bring up the TEST PATTERNS menu (MAIN MENU > DIAGNOSTICS), or send the following command : op B2 PATTERN?</p> | <ul style="list-style-type: none"> Choose None on the menu or send the command op B2 PATTERN=NONE |

If the Power Supply fan is Failed or shows Fault

If the Power Supply fan is “**failed**”:

- Make sure *all* Power Supply Modules are On.
- Make sure **PS Mon** in the master Quad Controller is connected.
- Check the fan indicator on *all* Power Supply Modules. If any are red, replace that Power Supply Module.

If the Power Supply shows “**fault**,”

- Make sure *all* Power Supply Modules are On.
- Make sure **PS Mon** on the master Quad Controller is connected.
- Check “**DC OK**” indicators on *all* Power Supply Modules
 - If one is **red**, replace that module.
 - If **all are red**, check the power meter on the rear of the modules.
 - If *all* lights are blinking rapidly, remove the last display panel in the loop to see if the problems is fixed.
 - If the problem is *not* fixed, remove *all* power connectors from the module to see if the problem is fixed.
 - If the problem is fixed, rebalance the load on that module.
 - If it is *not* fixed, replace the module.

Symptom: Picture Is Not Displaying Correctly

| Question | How to find the answer | Possible actions to take |
|---|---|---|
| 1 Is the colorspace correct? | Bring up the SETUP SUMMARY menu (MAIN MENU > DIAGNOSTICS) or read the setting with the following command: op B2 COLORSPACE? | <ul style="list-style-type: none"> Computer sources are usually RGB colorspace. Some video sources are YPbPr, if you see the image but the colors are wrong, try changing this setting. |
| 2 Are the gains and offsets correct for video vs. RGB levels? | See question 13 of the previous section. | <ul style="list-style-type: none"> Some video sources use a code of 16 instead of 0 for black and 235 instead of 255 for white. If this is the case, the image may appear to be washed out. In the Input Levels menu, choose "Set to Nominal for Video Levels (16-235) to display the image correctly. Conversely, computer sources will need to be set to RGB levels in order to display correctly. |
| 3 Is my source very high resolution or dual link? | If your source is more than 2047 pixels wide or tall or your source's input clock is higher than 165 MHz, it needs special treatment. | <ul style="list-style-type: none"> See "Configuring High Resolution Inputs" on page 140. |
| 4 Is the EDID correct for my source? | Open the EDID menu (MAIN MENU > ADVANCED OPTIONS > EDID). | <ul style="list-style-type: none"> Your computer is probably using Detailed Timing 1 or Detailed Timing 2 of the EDID to determine what resolution to output. If possible, set this menu to match the resolution you desire. See "Controlling EDID Behavior" on page 93. |

Servicing

You can remove or simply get access to the LCDs without removing other LCDs in the wall. Starting at the top of the wall, pull up and out to place them in service mode, allowing you to get to the LCDs below.

You can also completely remove and replace an LCD very quickly this way. Because of their streamlined design, they weigh less than typical LCD displays and are more easily handled.

Lift the top display and bring it forward about one inch (3cm). Lower it into the mount's hook or notch. Tilt the bottom of the display forward and lower the service mode arms on both sides.

Caution: When the LCD is in service mode, **do not unplug power while the LCD is on**. Use the remote control to turn off the LCD and *then* unplug the power cable. If you unplug the power cable when the LCD is still on, it could damage the LCD.

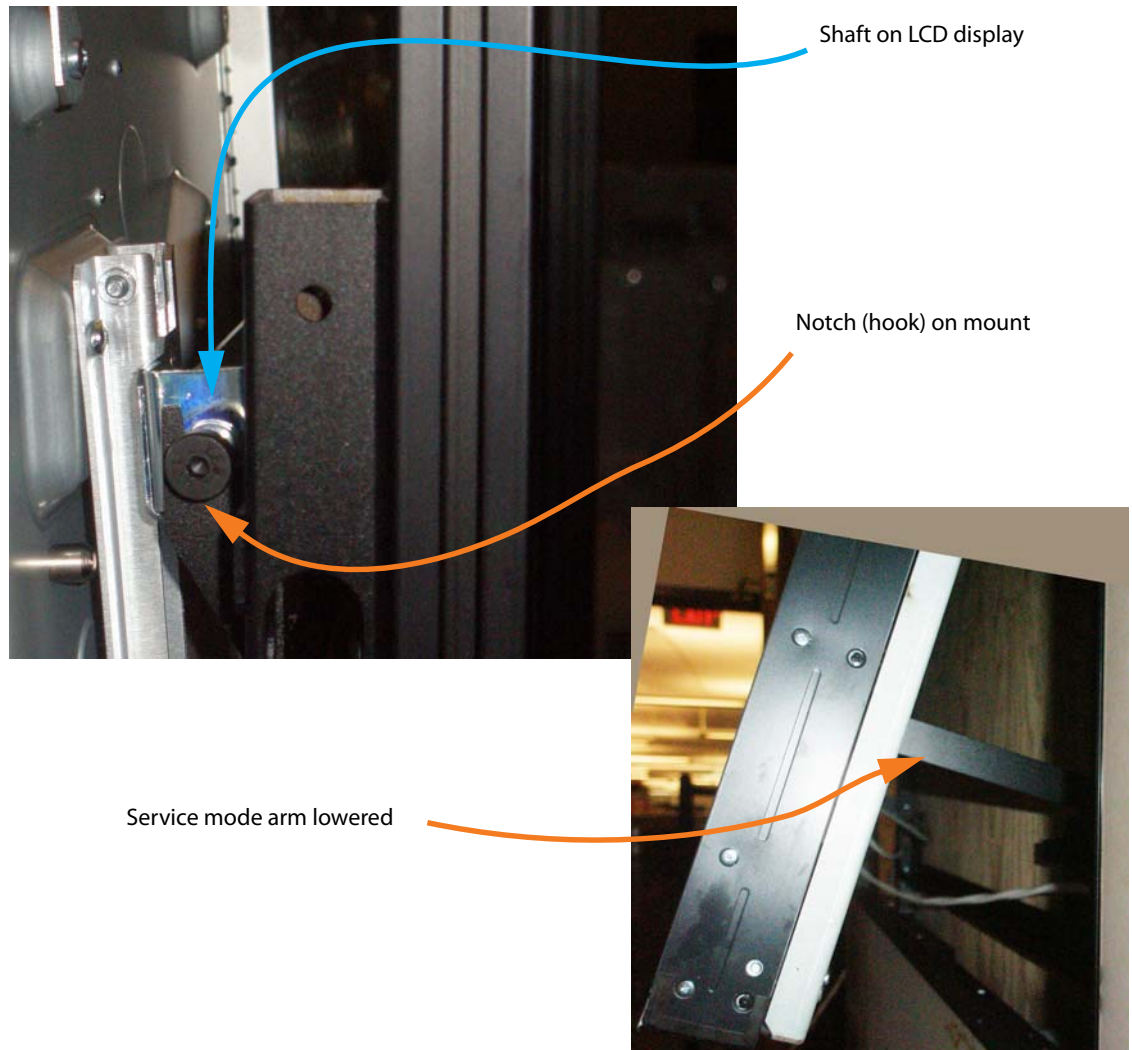

Specifications

LCD Module Specifications for MX46HDS, MX55HDS, MX46HDU, LX55HDU, MX55HDU

| Model Number > | MX46HDS | | MX55HDS | | MX46HDU | | LX/MX55HDU | |
|-------------------------|----------------------------------|--------|---------|--------|---------|--------|------------|--------|
| Dimensions in > | in/lbs | mm/kg | in/lbs | mm/kg | in/lbs | mm/kg | in/lbs | mm/kg |
| Panel | | | | | | | | |
| Width | 40.3" | 1024mm | 47.8" | 1215mm | 40.2" | 1022mm | 47.8" | 1213mm |
| Height | 22.7" | 579mm | 27" | 686mm | 22.7" | 577mm | 26.9" | 684mm |
| Diagonal overall | 46" | 1168mm | 55" | 1396mm | 46" | 1168mm | 55" | 1396mm |
| Depth installed | 3.5" | 90mm | 3.5" | 90mm | 3.5" | 90mm | 3.6" | 90mm |
| Weight | 36lbs | 16.3kg | 52lbs | 23.5kg | 34lbs | 15.4kg | 46lbs | 21kg |
| LCD Mount | | | | | | | | |
| Width - Landscape | 31.9" | 809mm | 32.9" | 837mm | 31.9" | 809mm | 32.9" | 837mm |
| Height - Landscape | 20.8" | 528mm | 25" | 636mm | 20.8" | 528mm | 25" | 636mm |
| Width - Portrait | 22.7" | 576mm | 26.6" | 677mm | 22.7" | 576mm | 26.6" | 677mm |
| Height - Portrait | 38.3" | 973mm | 45.9" | 1165mm | 38.3" | 297mm | 45.9" | 1165mm |
| Weight - Landscape | 7lbs | 3.2kg | 8lbs | 3.6kg | 7lbs | 3.2kg | 8lbs | 3.6kg |
| Weight - Portrait | 9lbs | 3.9kg | 10lbs | 4.5kg | 9lbs | 3.9kg | 10lbs | 4.5kg |
| Orientation | Landscape or portrait | | | | | | | |
| Maximum stack height | Unlimited landscape portrait | | | | | | | |
| Rear clearance required | None | | | | | | | |
| Aspect ratio | 16:9 (landscape) 9:16 (portrait) | | | | | | | |
| Backlight life | 50,000 (half brightness) | | | | | | | |

LCD Module Specifications for LX46HDS, LX55HDS

| Model Number > | LX46HDS | | LX55HDS | |
|-------------------------|----------------------------------|--------|---------|--------|
| Dimensions in ... | in/lbs | mm/kg | in/lbs | mm/kg |
| Panel | | | | |
| Width | 40.3" | 1024mm | 47.8" | 1215mm |
| Height | 22.7" | 579mm | 27" | 686mm |
| Diagonal overall | 46" | 1168mm | 55" | 1396mm |
| Depth installed | 4.2" | 107mm | 4.2" | 107mm |
| Weight | 38lbs | 17.2kg | 50lbs | 22.2kg |
| LCD Mount | | | | |
| Width - Landscape | 31.9" | 809mm | 32.9" | 837mm |
| Height - Landscape | 20.8" | 528mm | 25" | 636mm |
| Width - Portrait | 22.7" | 576mm | 26.6" | 677mm |
| Height - Portrait | 38.3" | 973mm | 45.9" | 1165mm |
| Weight - Landscape | 7lbs | 3.2kg | 8lbs | 3.6kg |
| Weight - Portrait | 9lbs | 3.9kg | 10lbs | 4.5kg |
| Orientation | Landscape or portrait | | | |
| Maximum stack height | Unlimited landscape portrait | | | |
| Rear clearance required | None | | | |
| Aspect ratio | 16:9 (landscape) 9:16 (portrait) | | | |
| Backlight life | 50,000 (half brightness) | | | |

LCD Module Specifications for LX46S-3D

| Model Number > | LX46S-3D | |
|-------------------------|--------------------------|--------|
| Dimensions in ... | in/lbs | mm/kg |
| Panel | | |
| Width | 40.4" | 1026mm |
| Height | 22.8" | 580mm |
| Diagonal overall | 46" | 1168mm |
| Depth installed | 3.6" | 90mm |
| Weight | 37lbs | 16.6kg |
| LCD Mount | | |
| Width - Landscape | 30.4" | 773mm |
| Height - Landscape | 20" | 508mm |
| Weight - Landscape | 8lbs | 3.6kg |
| Orientation | Landscape (only) | |
| Maximum stack height | Unlimited landscape | |
| Rear clearance required | None | |
| Aspect ratio | 16:9 (landscape) | |
| Backlight life | 50,000 (half brightness) | |

Quad Controller Module Specifications

| Specification | MG2-QC | | Connector | Notes |
|----------------|--------|-------|-------------|----------------|
| Dimensions | in/lbs | mm/kg | | |
| Width | 19" | 483mm | | |
| Height | 1.7" | 44mm | | |
| Depth | 18.2" | 463mm | | |
| Weight | 13lbs | 5.8kg | | |
| Power In | | | Mini DIN | 24-48V, 4A max |
| RS232 In/Out | | | RJ45 | |
| RS485 In/Out | | | RJ45 | |
| Video Input | | | HDMI | |
| Dual Link In | | | DisplayPort | |
| Video Loop Out | | | DisplayPort | |
| IR | | | 3.5mm | |
| PS Mon | | | RJ45 | |
| Video Out | | | RJ45 | |

Power Supply Module Specifications

| Specification | MG2-PSX | | Connector | Notes |
|---------------------------|---------|-------|--------------|-------|
| Dimensions | in/lbs | mm/kg | | |
| Width | 19" | 483mm | | |
| Height | 1.7" | 44mm | | |
| Depth | 18.2 | 463mm | | |
| Weight | | | | |
| PS3 | 16.7lbs | 7.6kg | | |
| PS3/R | 18.5lbs | 8.4kg | | |
| Power In | | | C20 AC Inlet | |
| Output to Quad Controller | | | Mini DIN | |
| Output to LCD module | | | Mini-Fit Sr | |
| PS Monitor Output | | | RJ45 | |
| Input Ratings | | | | |
| Input voltage | | | 100-240 VAC | |

Power Supply Module Specifications

| Specification | MG2-PSX | Connector | Notes |
|---------------------------|------------|---------------|--|
| Input frequency | | 50-60 Hz | |
| Input current | | | Under normal usage, AC should not exceed 16A at 120 VAC. |
| 115 VAC | 10.8A typ. | PS3 and PS3/R | |
| 230 VAC | 5.4A typ. | PS3 and PS3/R | |
| Inrush current 230 VAC | <60A | | |
| Output Ratings | | | |
| Output voltage | | 48 VDC | |
| Output current | | 25A 2A | PS3 and PS3/R max Per Quad Controller |

LCD Optical Specifications

| Specification | Maximum | Minimum | Typical |
|--|---------|----------|----------------------|
| Screen brightness | | | |
| MX46HDS, MX55HDS, MX55HDU, MX46HDU | | 600 cd/m | 700 cd/m |
| LX46HD, LX55HDS, LX46-3D, LX55HDU | | 400 cd/m | 450 cd/m |
| Contrast ratio | | | |
| MX46HDS, LX46HDS, LX55HDS, MX55HDU, LX55HDU, MX46HDU | | 2500:1 | 3500:1 |
| MX55HDS | | 3000:1 | 3500:1 |
| Uniformity | | 75% | |
| Viewing Angle, horizontal & vertical | | | ±178° |
| Color gamut | | | 72% NTSC 100% EBU |
| Color CIE - Native | | | |

LCD Optical Specifications (Continued)

| Specification | Maximum | Minimum | Typical |
|---------------------------|---------|---------|-------------------------------|
| MX46HDS LCD module | | | |
| Red (x,y) | | | 0.646, 0.335 |
| Green (x,y) | | | 0.310, 0.597 |
| Blue (x,y) | | | 0.151, 0.068 |
| White (x,y) | | | 0.280, 0.290 |
| MX46HDU LCD module | | | |
| Red (x,y) | | | 0.638, 0.331 |
| Green (x,y) | | | 0.300, 0.608 |
| Blue (x,y) | | | 0.153, 0.055 |
| White (x,y) | | | 0.263, 0.268 |
| MX55HDS LCD module | | | |
| Red (x,y) | | | 0.620, 0.330 |
| Green (x,y) | | | 0.303, 0.630 |
| Blue (x,y) | | | 0.150, 0.550 |
| White (x,y) | | | 0.280, 0.290 |
| MX55HDU LCD Module | | | |
| Red (x,y) | | | 0.620, 0.330 |
| Green (x,y) | | | 0.303, 0.630 |
| Blue (x,y) | | | 0.150, 0.055 |
| White (x,y) | | | 0.280, 0.290 |
| LX46HDS LCD module | | | |
| Red (x,y) | | | 0.646, 0.335 |
| Green (x,y) | | | 0.310, 0.597 |
| Blue (x,y) | | | 0.151, 0.068 |
| White (x,y) | | | 0.280, 0.290 |
| LX55HDS LCD module | | | |
| Red (x,y) | | | 0.644, 0.335 |
| Green (x,y) | | | 0.307, 0.597 |
| Blue (x,y) | | | 0.151, 0.063 |
| White (x,y) | | | 0.280, 0.280 |
| LX55HDU LCD module | | | |
| Red (x,y) | | | 0.640, 0.328 |
| Green (x,y) | | | 0.295, 0.622 |
| Blue (x,y) | | | 0.156, 0.048 |
| White (x,y) | | | 0.277, 0.301 |
| LX46S-3D LCD module | | | |
| Red (x,y) | | | 0.643, 0.328 |
| Green (x,y) | | | 0.271, 0.599 |
| Blue (x,y) | | | 0.143, 0.060 |
| White (x,y) | | | 0.280, 0.290 |
| Color Temperature Presets | | | 3200K, 5500K, 6500K, 8500K |
| Native color temperature | | | 10,000K |
| Number of colors | | | 16.7M |

LCD Optical Specifications (Continued)

| Specification | Maximum | Minimum | Typical |
|-------------------|---------|---------|--------------------|
| Native resolution | | | |
| MX**HDS | | | 1920 x 1080 pixels |
| LX**HDS | | | 1920 x 1080 pixels |
| MX**HDU | | | 1920 x 1080 pixels |
| LX46S | | | 1336 x 768 pixels |

Environmental Specifications

| Specification | Maximum | Minimum | Optimal | Notes |
|---------------------------------------|-----------------|-----------------|--------------------|--|
| Temperature | | | | All performance specifications are maintained within this temperature range. |
| operating, LCD module | 35° C 95° F | 5° C 41° F | 20° C +/- 3° C | |
| operating, Quad Controller module | 40° C 113° F | 10° C 50° F | 20° C 68° F | |
| operating, Power supply module | 40° C 113° F | 10° C 50° F | 20° C 68° F | |
| non-operating, LCD module | 50° C 122° F | -20° C -4° F | 20° C +/- 10° C | |
| non-operating, Quad Controller module | 85° C 122° F | -20° C -4° F | | |
| non-operating, Power supply module | 85° C 122° F | -20° C -4° F | | |
| Fan Noise | | | | |
| LCD module | N/A - no fan | | | |
| Quad Controller module | 45dB | | | |
| Power supply module | 45dB | | | |
| Altitude (barometric pressure) | 2000m | | | Above sea level, or equivalent barometric pressure. De-rate temperature 10° for every 1km above 1000m. |
| Humidity | | | | |
| operating, LCD module | 80% R.H. | 20% R.H. | | non-condensing |
| operating, Quad Controller module | 80% R.H. | 20% R.H. | | |
| operating, Power supply module | 80% R.H. | 20% R.H. | | |

Note: This is the minimum supported signal mode table. Signal timings and formats other than those listed below may also be supported.

* RB = Reduced Blanking

Signal Compatibility

| Signal Type | Resolution | Frame Rate (Hz) | Line Rate (kHz) | Pixel Rate (MHz) | HDMI – RGB | HDMI – YUV | DisplayPort – RGB | DisplayPort – YUV | References |
|-------------|------------|-----------------|-----------------|------------------|------------|------------|-------------------|-------------------|------------|
| PC | 640x480 | 59.94 | 31.47 | 25.175 | x | x | x | x | VESA DMT |
| | 640x480 | 72 | 37.86 | 31.5 | x | | x | | VESA DMT |
| | 640x480 | 74.99 | 37.5 | 31.5 | x | | x | | VESA DMT |
| | 640x480 | 85 | 43.27 | 36 | x | | x | | VESA DMT |
| | 800x600 | 56 | 35.16 | 36 | x | | x | | VESA DMT |
| | 800x600 | 60.32 | 37.89 | 40 | x | | x | | VESA DMT |
| | 800x600 | 72 | 48.08 | 50 | x | | x | | VESA DMT |
| | 800x600 | 75 | 46.88 | 49.5 | x | | x | | VESA DMT |
| | 800x600 | 85.06 | 53.67 | 56.25 | x | | x | | VESA DMT |
| | 848x480 | 60 | 30 | 21.68 | x | | x | | VESA CVT |
| | 1024x768 | 50 | 40.6 | 54.57 | x | | x | | VESA CVT-R |
| | 1024x768 | 60 | 47.82 | 63.5 | x | | x | | VESA CVT |
| | 1024x768 | 60 | 48.36 | 65 | x | | x | | VESA DMT |
| | 1024x768 | 70 | 56.48 | 75 | x | | x | | VESA DMT |
| | 1024x768 | 75.03 | 60.02 | 78.75 | x | | x | | VESA DMT |
| | 1024x768 | 85.03 | 68.68 | 94.5 | x | | x | | VESA DMT |
| | 1024x1024 | 60 | 32.33 | 42.677 | x | | x | | VESA DMT |
| | 1152x864 | 70.01 | 63.85 | 94.5 | x | | x | | VESA DMT |
| | 1152x864 | 75 | 67.5 | 108 | x | | x | | VESA DMT |
| | 1152x864 | 85 | 77.09 | 121.5 | x | | x | | VESA DMT |

Signal Compatibility (cont.)

| Signal Type | Resolution | Frame Rate (Hz) | Line Rate (kHz) | Pixel Rate (MHz) | HDMI – RGB | HDMI – YUV | DisplayPort – RGB | DisplayPort – YUV | References |
|-------------|------------|-----------------|-----------------|------------------|------------|------------|-------------------|-------------------|------------|
| PC (cont.) | 1280x768 | 60 | 47.4 | 68.25 | x | | x | | VESA DMT |
| | 1280x768 | 60 | 47.78 | 79.5 | x | | x | | VESA CVT |
| | 1280x768 | 74.89 | 60.29 | 102.25 | x | | x | | VESA CVT |
| | 1280x768 | 84.84 | 68.63 | 117.5 | x | | x | | VESA CVT |
| | 1280x960 | 60 | 60 | 108 | x | | x | | VESA DMT |
| | 1280x960 | 75 | 75 | 126 | x | | x | | VESA DMT |
| | 1280x960 | 85 | 85.94 | 148.5 | x | | x | | VESA DMT |
| | 1280x1024 | 60.02 | 63.98 | 108 | x | | x | | VESA DMT |
| | 1280x1024 | 75.02 | 79.98 | 135 | x | | x | | VESA DMT |
| | 1280x1024 | 85.02 | 91.15 | 157.5 | x | | x | | VESA DMT |
| | 1360x768 | 60 | 47.71 | 85.5 | x | | x | | VESA DMT |
| | 1366x768 | 60 | 50 | 80 | x | | x | | VESA DMT |
| | 1400x1050 | 49.97 | 54.11 | 100 | x | | x | | VESA CVT |
| | 1400x1050 | 60 | 64.7 | 101 | x | | x | | VESA CVT-R |
| | 1400x1050 | 60 | 65.32 | 121.75 | x | | x | | VESA CVT |
| | 1400x1050 | 74.87 | 82.28 | 156 | x | | x | | VESA CVT |
| | 1600x1200 | 60 | 75 | 162 | x | | x | | VESA DMT |
| | 1680x1050 | 49.97 | 54.12 | 119.5 | x | | x | | VESA CVT-R |
| | 1680x1050 | 59.95 | 65.29 | 146.25 | x | | x | | VESA CVT |
| | 1920x1080 | 49.93 | 55.62 | 141.5 | x | | x | | VESA CVT |
| | 1920x1080 | 59.95 | 66.59 | 138.5 | x | | x | | VESA CVT-R |
| | 1920x1200 | 49.93 | 61.82 | 158.25 | x | | x | | VESA CVT |
| | 1920x1200 | 59.95 | 74.04 | 154 | x | | x | | VESA CVT-R |
| 2560x1440 | 59.95 | 88.79 | 241.5 | | | x | | VESA CVT-R | |
| 2560x1600 | 59.97 | 98.71 | 268.5 | | | x | | VESA CVT-R | |

Signal Compatibility (cont.)

| Signal Type | Resolution | Frame Rate (Hz) | Line Rate (kHz) | Pixel Rate (MHz) | HDMI – RGB | HDMI – YUV | DisplayPort – RGB | DisplayPort – YUV | References |
|-------------|------------|-----------------|-----------------|------------------|------------|------------|-------------------|-------------------|---|
| Specialty | 960x1080 | 60 | 67.2 | 86.01 | x | | x | | VESA CVT |
| | 960x2160 | 60 | 132 | 148.5 | x | | x | | VESA CVT-R |
| | 2732x1536 | 30 | 46.88 | 162.68 | x | | x | | VESA CVT-R |
| | 2732x1536 | 60 | 94.8 | 274.54 | | | x | | VESA CVT-R |
| | 4080x768 | 30 | 23.45 | 115.61 | x | | x | | VESA CVT-R |
| | 4080x768 | 60 | 47.7 | 254.96 | | | x | | VESA CVT-R |
| | 1366x2304 | 30 | 70.12 | 107.15 | x | | x | | VESA CVT-R |
| | 3840x1080 | 30 | 32.97 | 131.88 | x | | x | | VESA CVT-R |
| | 3840x1080 | 60 | 67.5 | 297 | | | x | | CEA-861-E, VIC 16, with horizontal parameters doubled |
| | 1920x2160 | 30 | 65.73 | 136.72 | x | | x | | VESA CVT-R |
| | 1920x3240 | 24 | 78.65 | 163.58 | x | | x | | VESA CVT-R |
| | 640x480 | 60 | 31.5 | 25.2 | x | | x | | VESA DMT |
| Apple Mac | 1024x768 | 59.28 | 48.19 | 64 | x | | x | | VESA DMT |
| | 1024x768 | 74.93 | 60.24 | 80 | x | | x | | VESA CVT |
| | 1152x870 | 60 | 54.17 | 82.34 | x | | x | | VESA DMT |
| | 1152x870 | 75.06 | 68.32 | 104.94 | x | | x | | VESA DMT |
| | 1280x800 | 60 | 49.7 | 83.499 | x | | x | | VESA DMT |
| | 1440x900 | 60 | 55.94 | 106.5 | x | | x | | VESA CVT |
| | 1600x900 | 60 | 56 | 118.35 | x | | x | | VESA DMR |
| | 1680x1050 | 60 | 65.34 | 146.36 | x | | x | | VESA CVT |
| | 2560x1440 | 60 | 86 | 241.7 | | | x | | VESA CVT-R |
| | 2560x1600 | 60 | 98.76 | 268.63 | | | x | | VESA CVT-R |

Signal Compatibility (cont.)

| Signal Type | Resolution | Frame Rate (Hz) | Line Rate (kHz) | Pixel Rate (MHz) | HDMI – RGB | HDMI – YUV | DisplayPort – RGB | DisplayPort – YUV | References |
|-------------|-------------|-----------------|-----------------|------------------|------------|------------|-------------------|-------------------|---------------------------------------|
| SDTV | 480p | 59.94 | | | x | x | x | x | SMPTE 293M, CEA-861-E |
| EDTV | 576p | 50 | | | x | x | x | x | ITU-R BT.1358, CEA-861-E |
| HDTV | 1080i | 50 | | | x | x | x | x | SMPTE 274M, CEA-861-E |
| | 1080i (Aus) | 50 | | | x | x | x | x | SMPTE 295M, AS 4933.1-2005, CEA-861-E |
| | 1080i | 60 | | | x | x | x | x | SMPTE 274M, CEA-861-E |
| | 720p | 50 | | | x | x | x | x | SMPTE 296M, CEA-861-E |
| | 720p | 60 | | | x | x | x | x | SMPTE 296M, CEA-861-E |
| | 1080p | 24 | | | x | x | x | x | SMPTE 274M, CEA-861-E |
| | 1080p | 25 | | | x | x | x | x | SMPTE 274M, CEA-861-E |
| | 1080p | 30 | | | x | x | x | x | SMPTE 274M, CEA-861-E |
| | 1080p | 50 | | | x | x | x | x | SMPTE 274M, CEA-861-E |
| UHDTV | 3840x2160 | 24 | 52.44 | 209.75 | | | x | x | VESA CVT-R |
| | 3840x2160 | 24 | 54 | 297 | | | x | x | SMPTE ST 2036-1:2009, HDMI 1.4b VIC 1 |
| | 3840x2160 | 25 | 56.25 | 297 | | | x | x | SMPTE ST 2036-1:2009, HDMI 1.4b VIC 2 |
| | 3840x2160 | 25 | 54.63 | 218.5 | | | x | x | VESA CVT-R |
| | 3840x2160 | 30 | 65.69 | 262.75 | | | x | x | VESA CVT-R |
| | 3840x2160 | 30 | 67.5 | 297 | | | x | x | SMPTE ST 2036-1:2009, HDMI 1.4b VIC 3 |

Input Minimum Sync and Blanking Specifications

| Parameter | Symbol | Minimum Horizontal Setting | Minimum Vertical Setting |
|------------------------|----------|----------------------------------|--------------------------|
| Sync pulse width | T_{SY} | 2 pixels | 2 lines |
| Sync back porch width | T_{BP} | 20 pixels 64 (tri-level sync) | 3 lines |
| Sync front porch width | T_{FP} | 1% of HRes | 1 line |

Note: The following illustration shows the timing characteristics for the Input Sync, Front Porch and Back Porch.

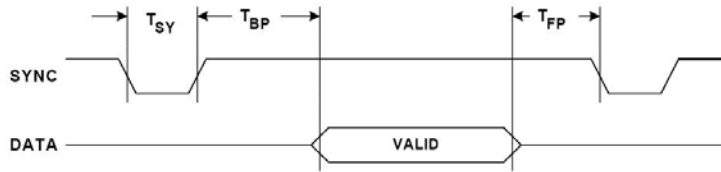

Cleaning the ERO Matrix Wall

Required Materials

- IPA (Isopropyl Alcohol)
- Filtered Water
- Non-Abrasive cloth (cotton or polyester based)
- Nitrile/Latex Gloves

Silicone Removal

Note: Wear gloves to protect your skin from IPA and to reduce fingerprints.

- 1 Fold a small cloth into a small square as shown.



- 2 Wet the cloth with IPA. *Do not soak* the cloth. Cloth must be dampened, but not have excess IPA running off into the bond area at the edges of the screen.
- 3 *Using one motion in one direction*, wipe along the edge of the display to remove silicone. Do not rub the cloth back and forth; that will smear the silicone.



- 4 Do not exceed two wipes per surface of the cloth. Turn over, fold, or use a new cloth for the next wipes



Caution: Do not wipe the seam between the displays. This can pull material out of the seam and spread it onto the display.

Caution: Be careful not to remove too much material from the seam.

WARNING Abrasive cleaning or too much pressure may cause damage to the glass coating.

WARNING Do not stick anything between the displays. This can pull the mullion away from the display or pull material out of the seam.

Cleaning the Glass

- To remove difficult water spots or fingerprints, wipe with filtered water followed immediately with IPA.
- Wipe gently and in a uniform motion across the glass to prevent streaking.

Matrix Drawings

Click below to go to the drawings you want.

Drawings of LCD Displays

- MX46HDS Dimensions – Landscape
- MX46HDS Dimensions – Portrait
- MX55HDS Dimensions – Landscape
- MX55HDS Dimensions – Portrait
- LX46HDS Dimensions – Landscape
- LX46HDS Dimensions – Portrait
- LX55HDS Dimensions – Landscape
- LX55HDS Dimensions – Portrait
- LX46S-3D Dimensions Landscape (only))
- MX46HDU Dimensions – Landscape
- MX46HDU Dimensions – Portrait
- LX/MX55HDU Dimensions – Landscape
- LX/MX55HDU Dimensions – Portrait

Drawings of Display Mounts

- LX/MX55HDU and LX55HDS – Landscape
- LX/MX55HDU and LX55HDS – Portrait
- MX46HDU, MX46HDS, and LX46HDS – Landscape
- MX46HDU, MX46HDS, and LX46HDS – Portrait
- MX55HDS – Landscape
- MX55HDS – Portrait
- LX46S-3D – Landscape (only)

Dimensions of Electronic Components

- Power Supply Module
- Quad Controller Module
- Main DC Power Cable
- Power Supply to Quad Power Cable

Note: More drawings are available online as CADs if you need further details.

MX46HDS Dimensions – Landscape

MX46HDS Front, Top, and Bottom Views – Landscape

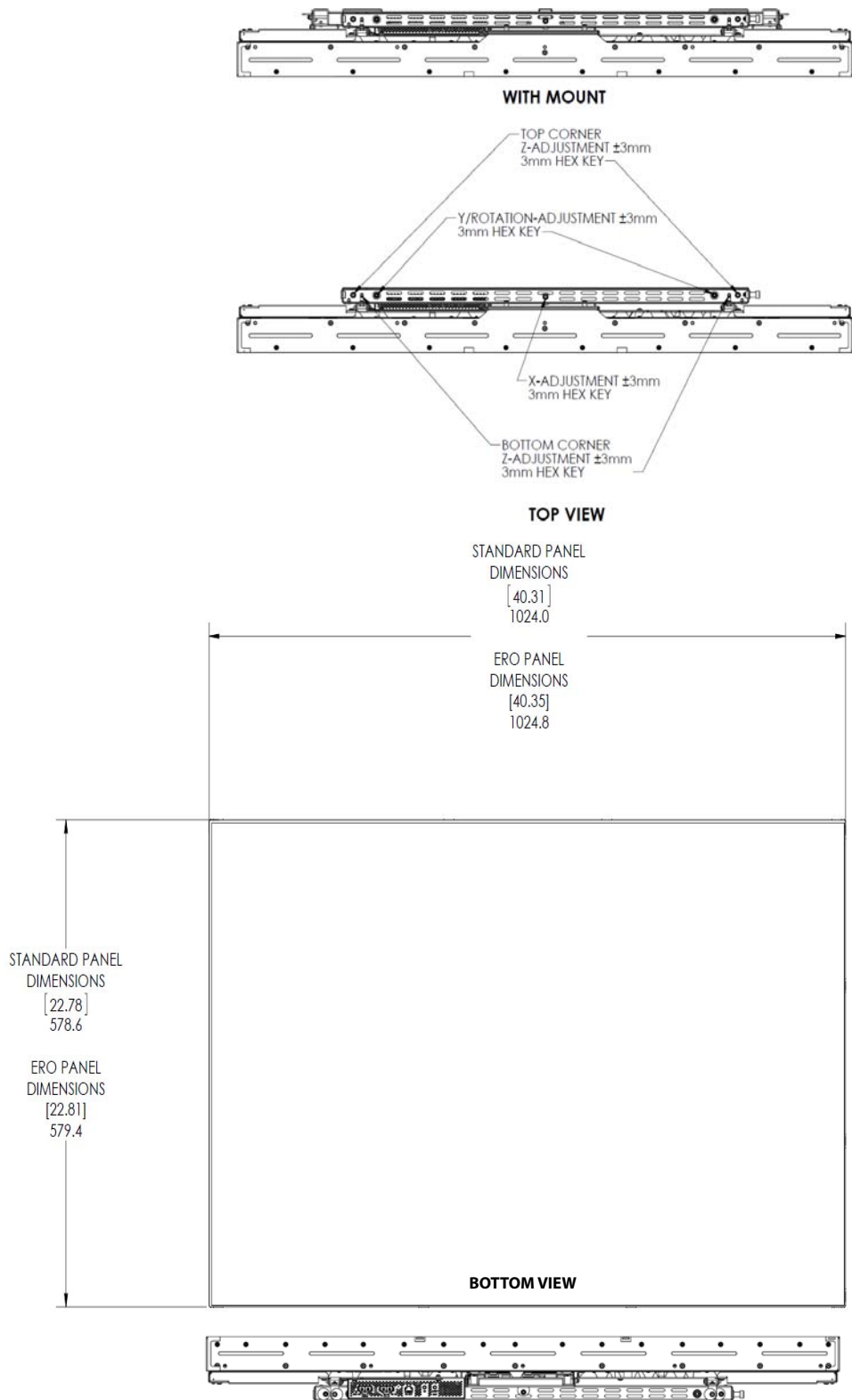

MX46HDS Rear View – Landscape

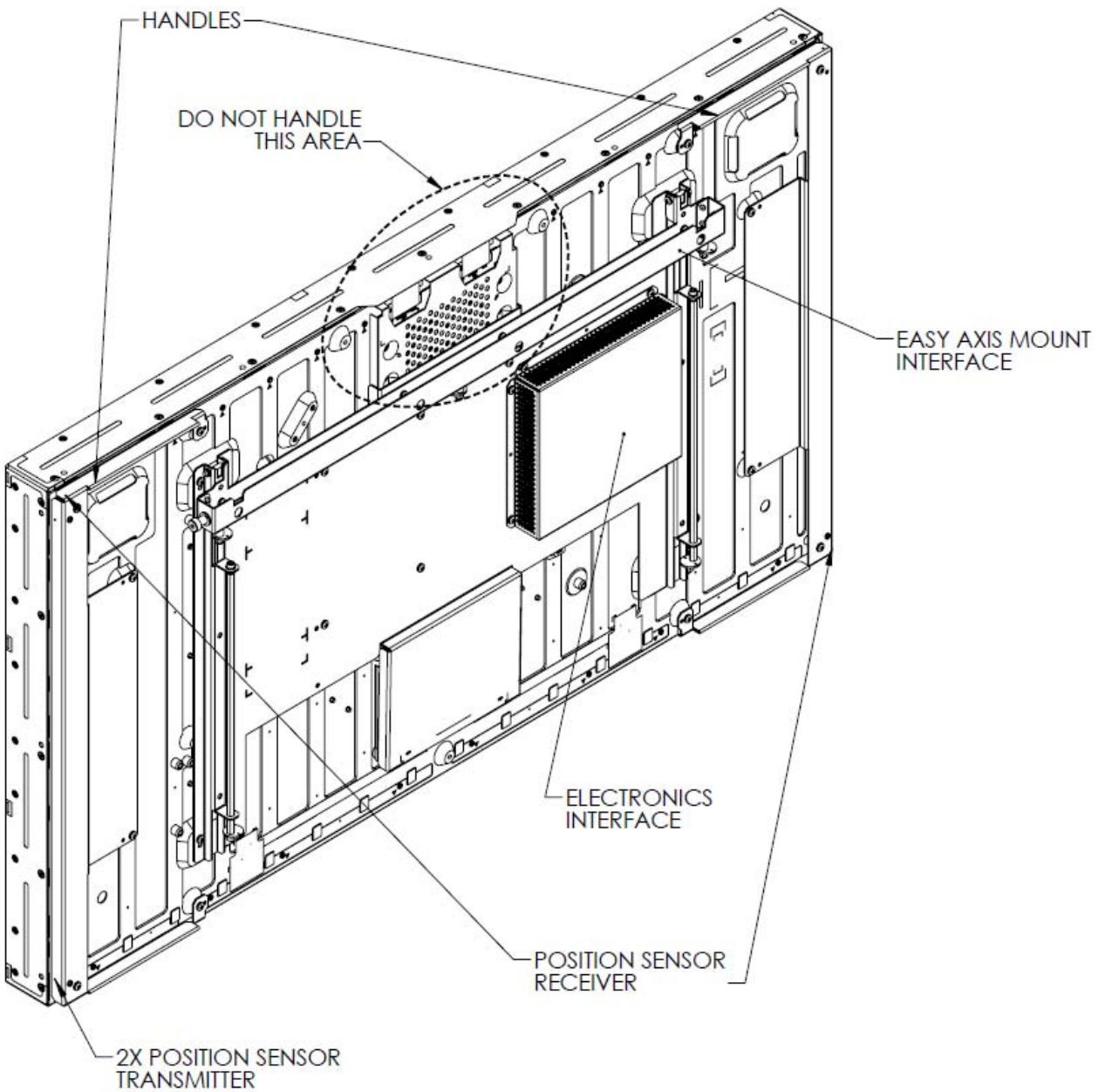

MX46HDS Side View – Landscape

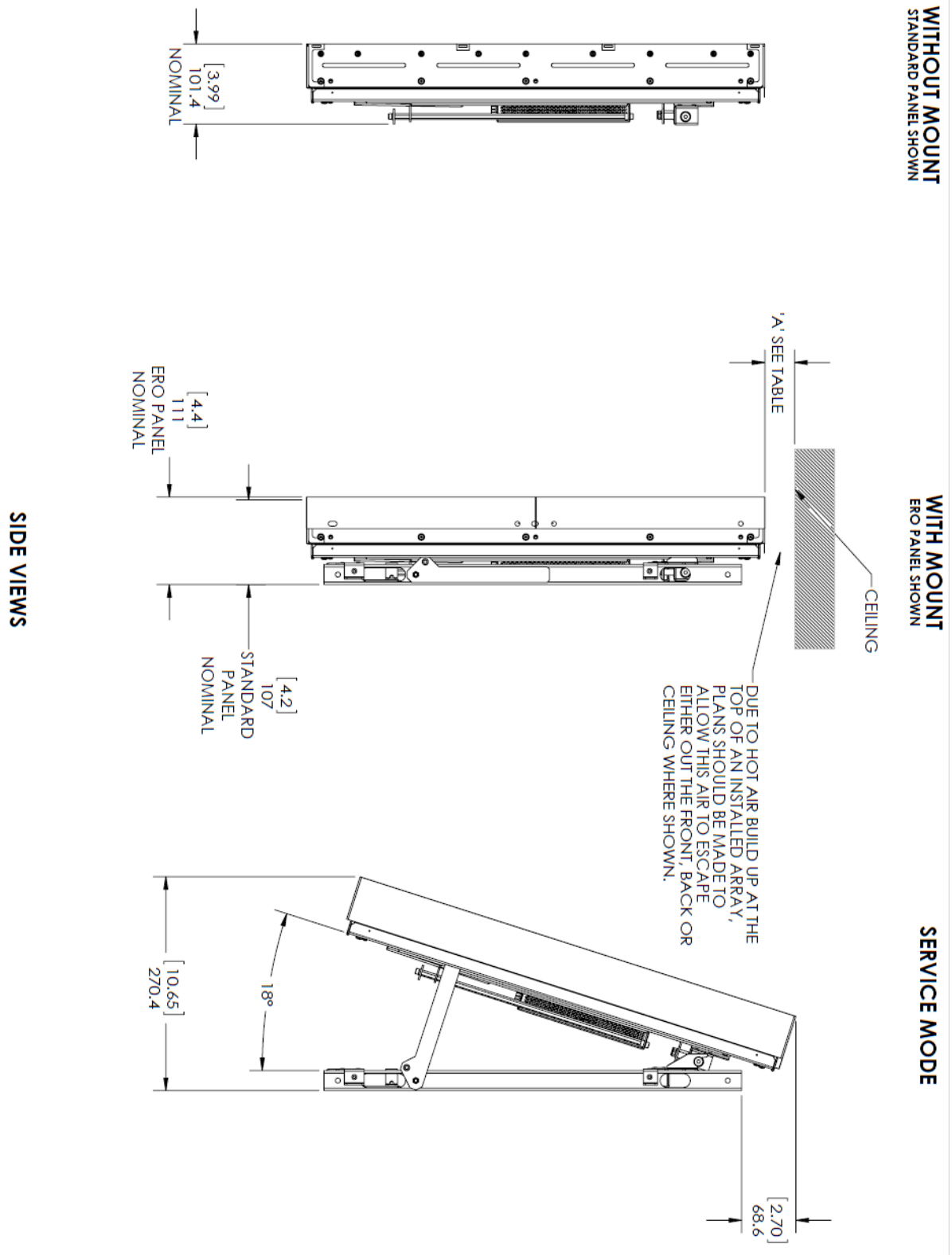

MX46HDS Dimensions – Portrait

MX46HDS Top and Bottom Views – Portrait

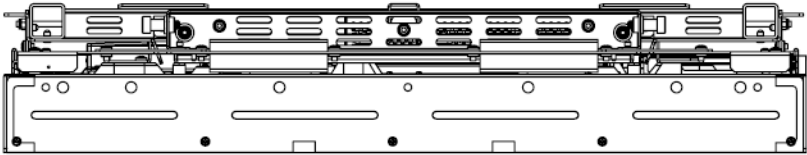

WITH MOUNT

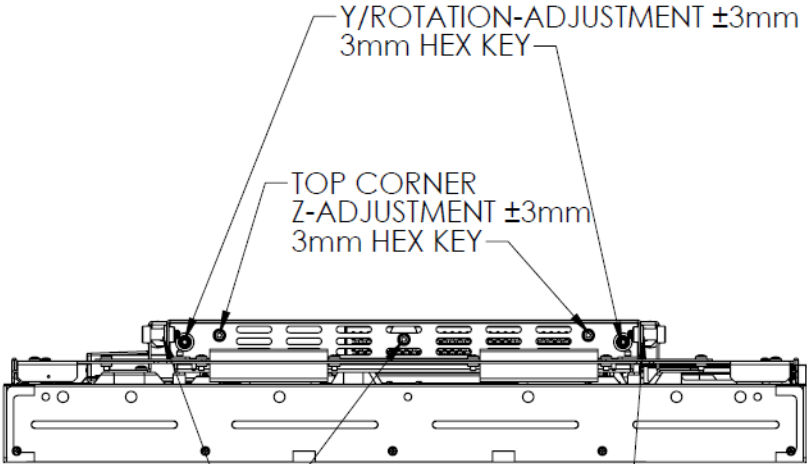

TOP VIEW

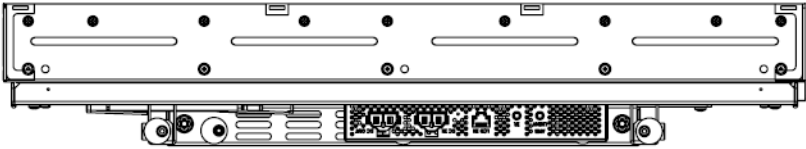

BOTTOM VIEW

MX46HDS Front View – Portrait

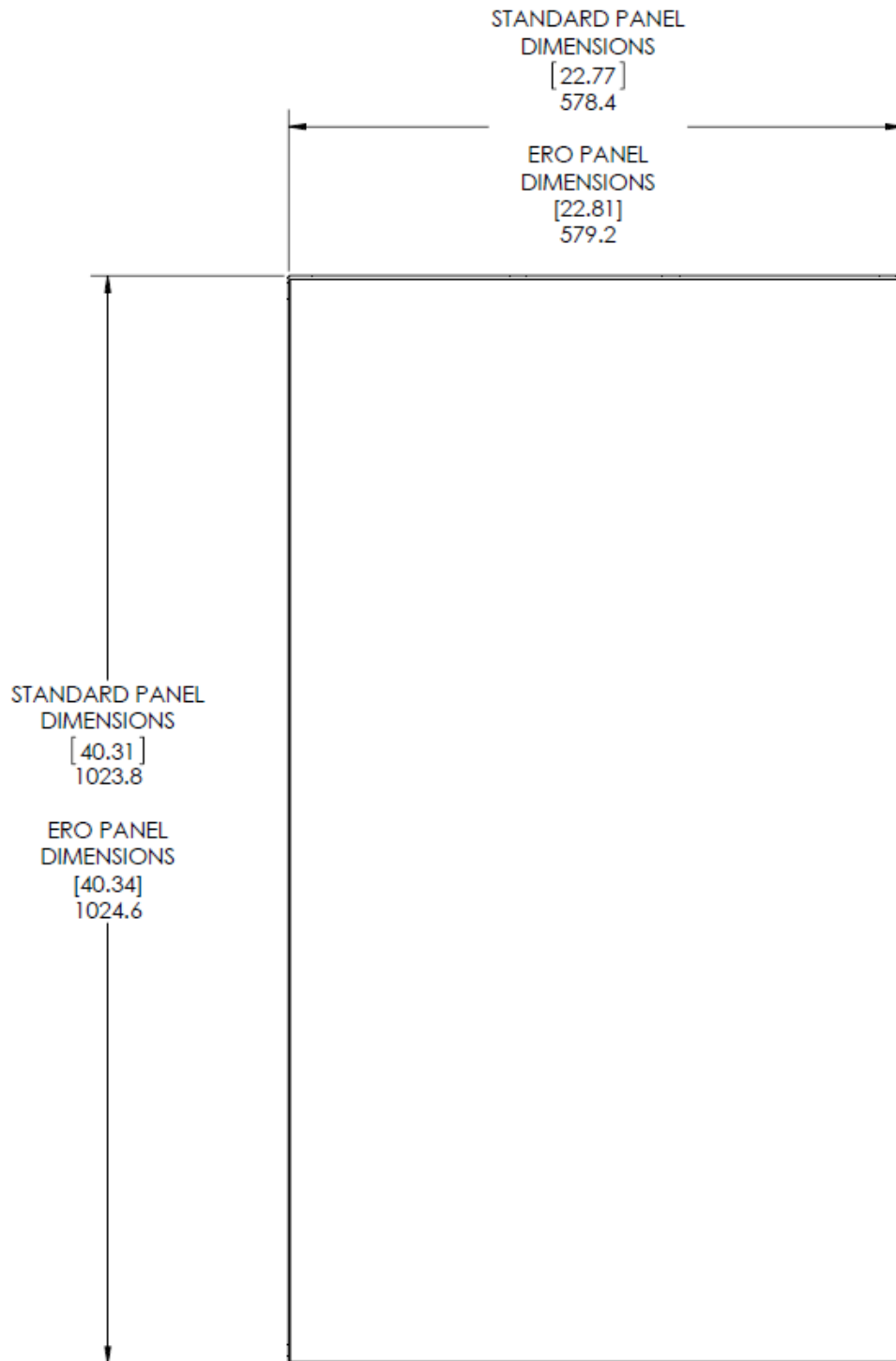

FRONT VIEW
STANDARD PANEL SHOWN

MX46HDS Rear View – Portrait

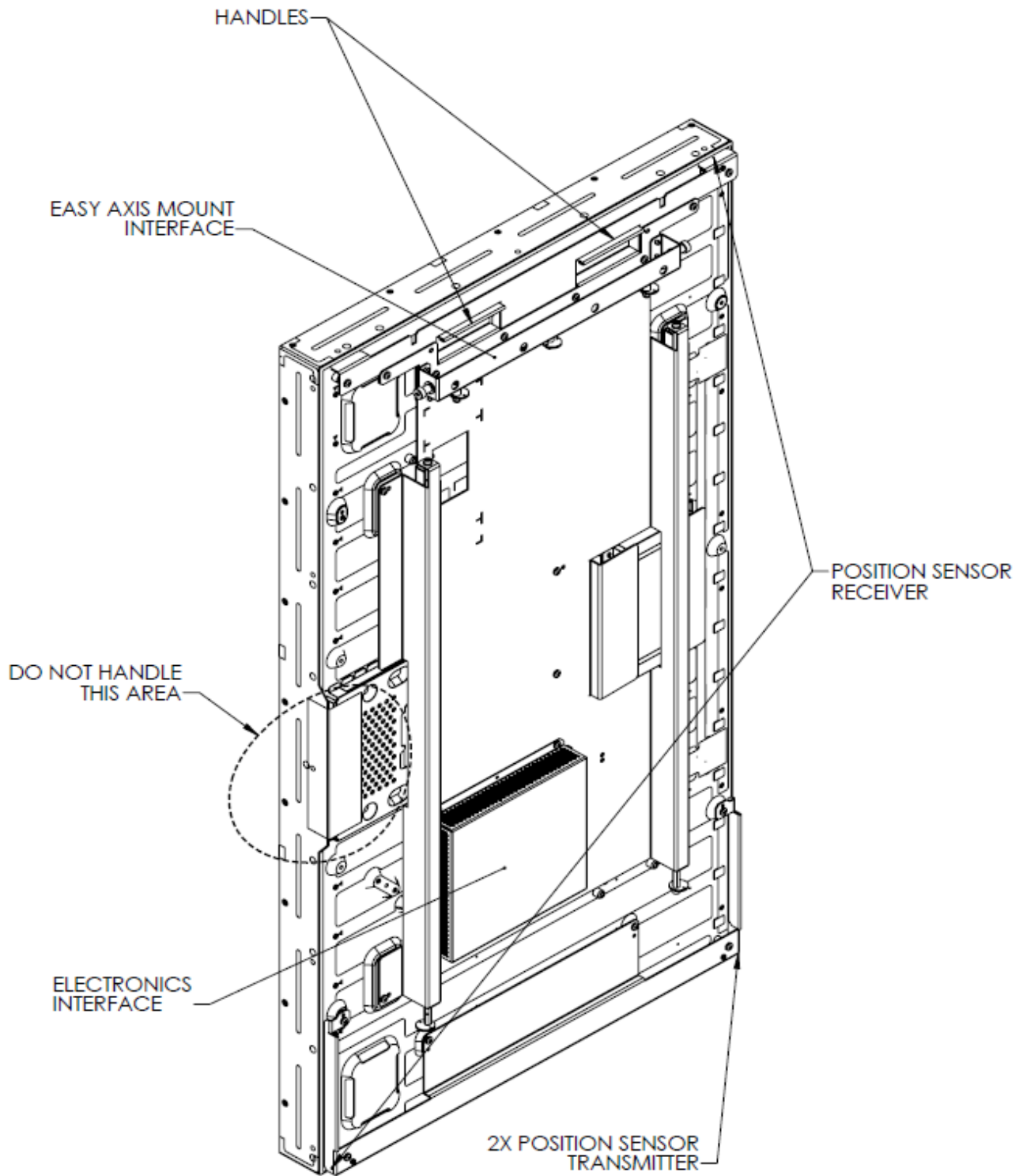

MX46HDS Side View – Portrait

WITHOUT MOUNT
STANDARD PANEL SHOWN

WITH MOUNT
ERO PANEL SHOWN

SERVICE MODE

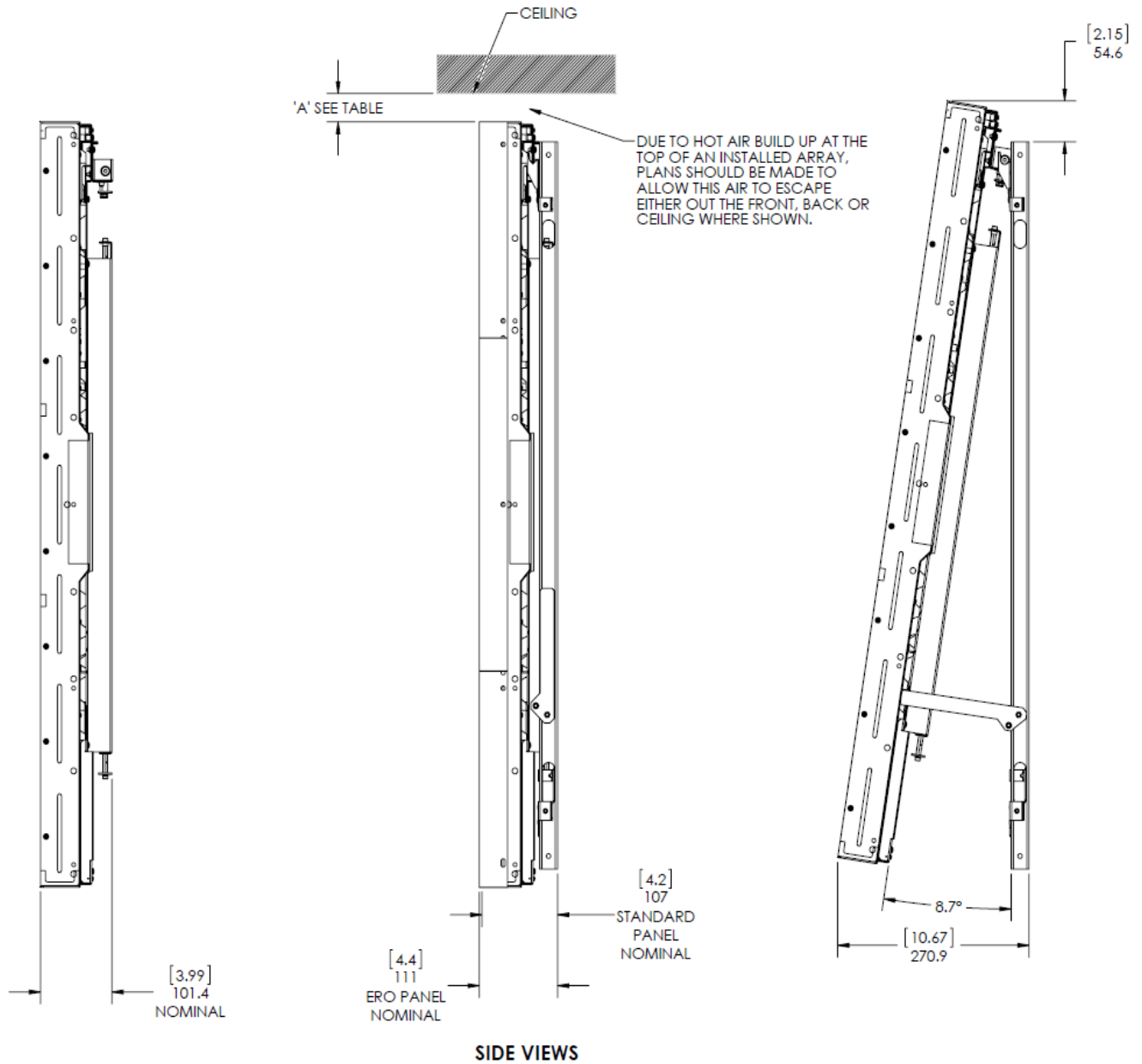

MX55HDS Dimensions – Landscape

MX55HDS Top, Front, and Bottom Views – Landscape

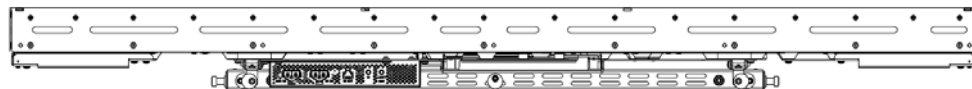
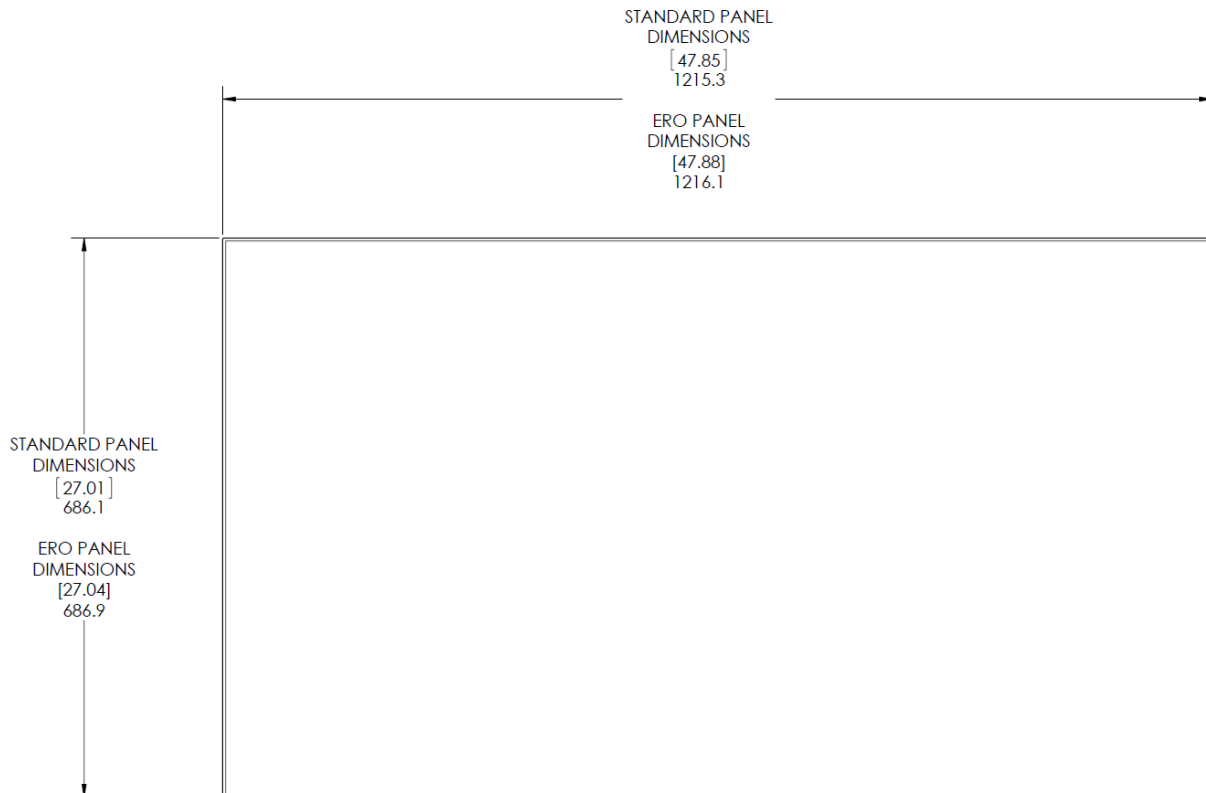
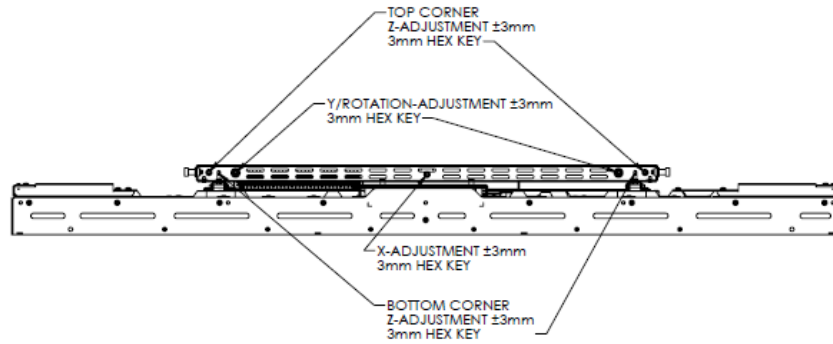
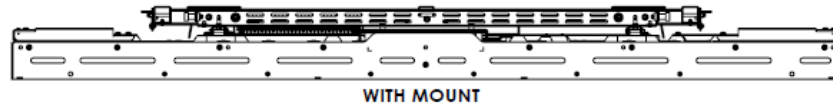

MX55HDS Rear View – Landscape

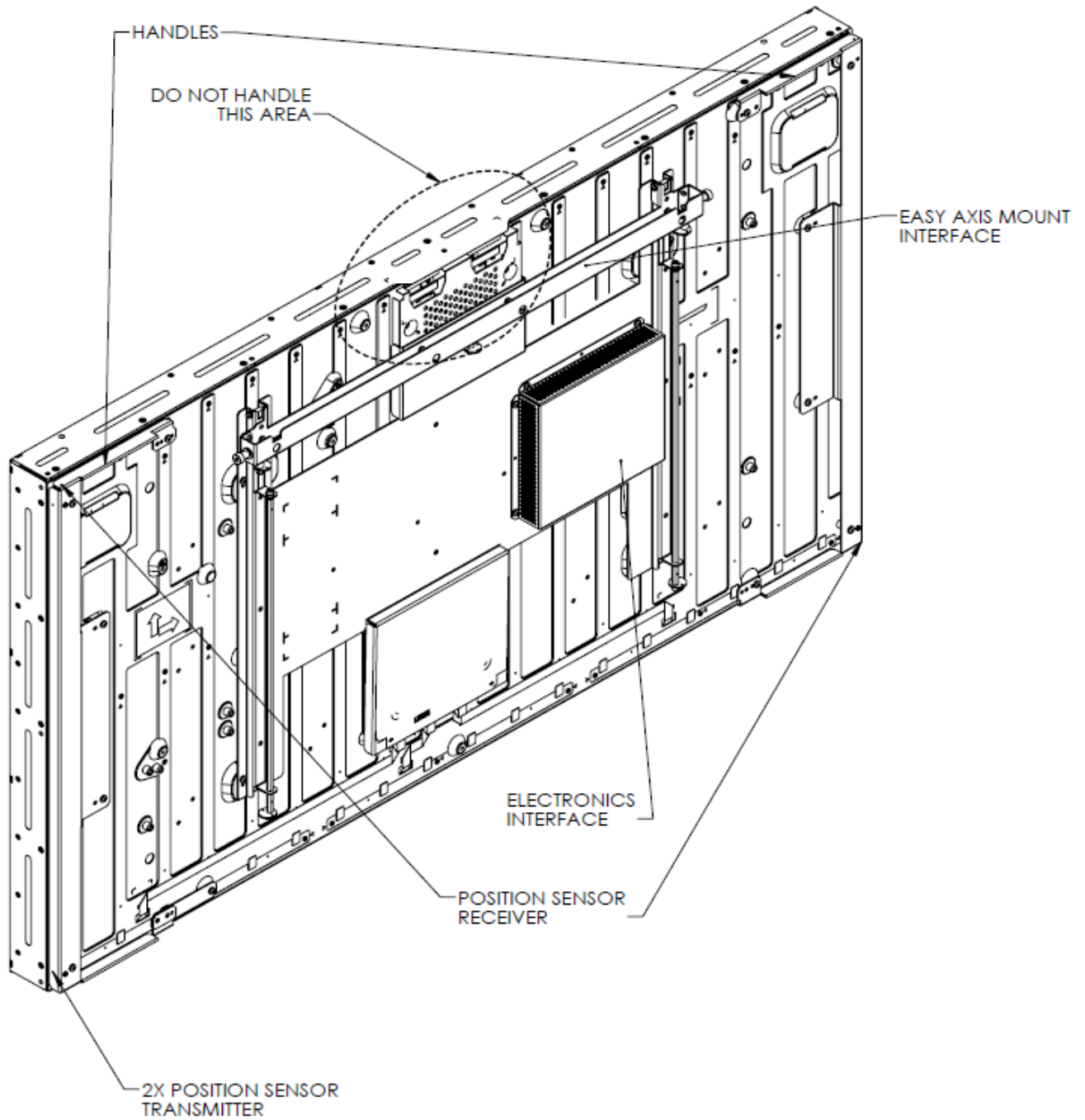

MX55HDS Side View – Landscape

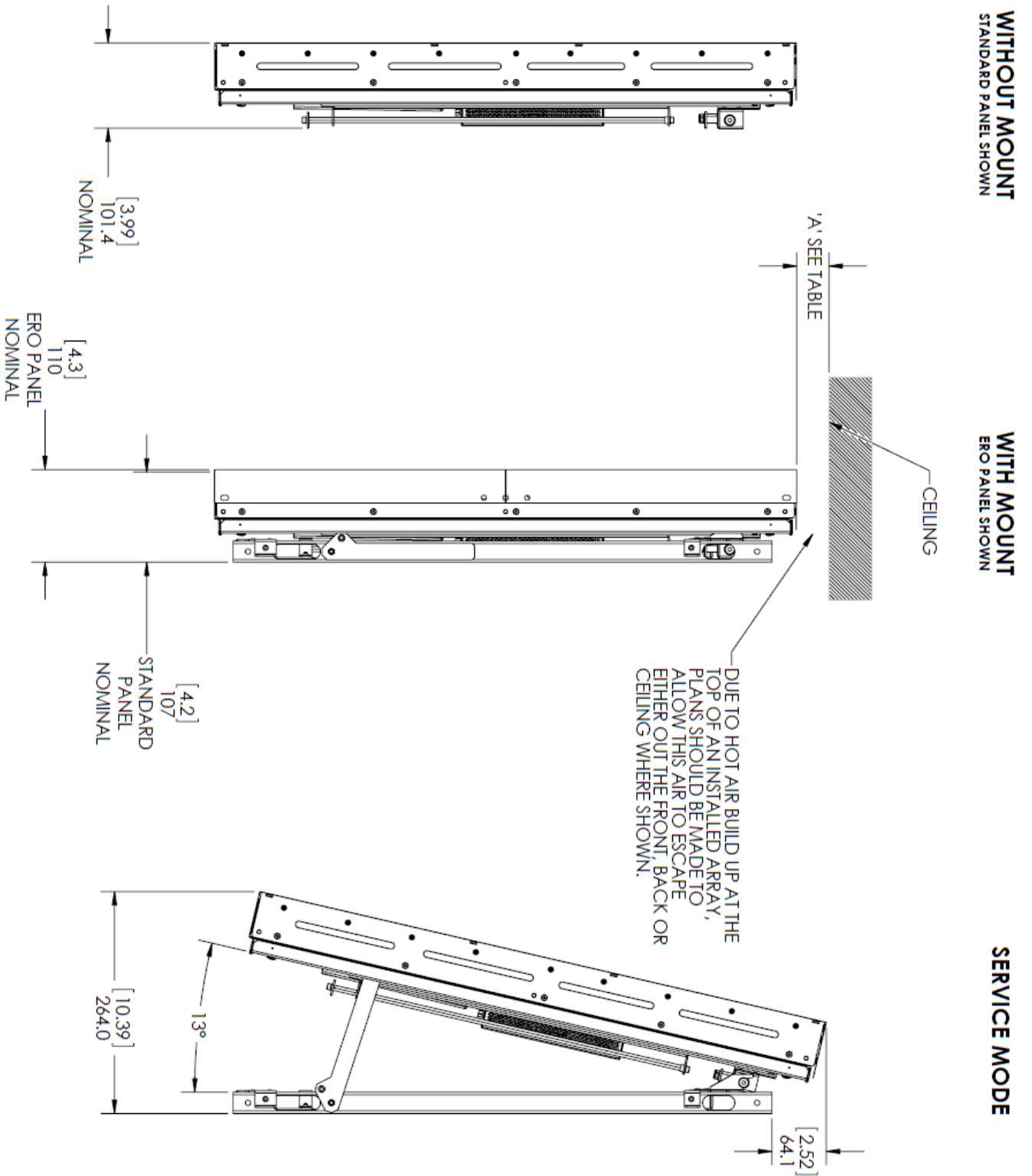

MX55HDS Dimensions – Portrait

MX55HDS Top and Bottom – Portrait

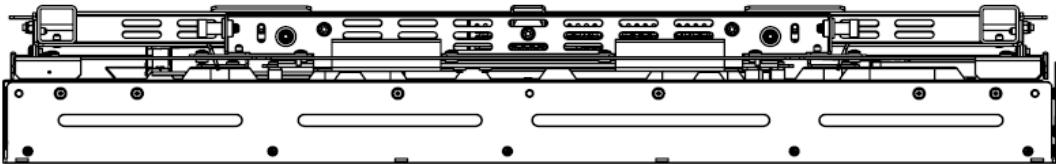

WITH MOUNT

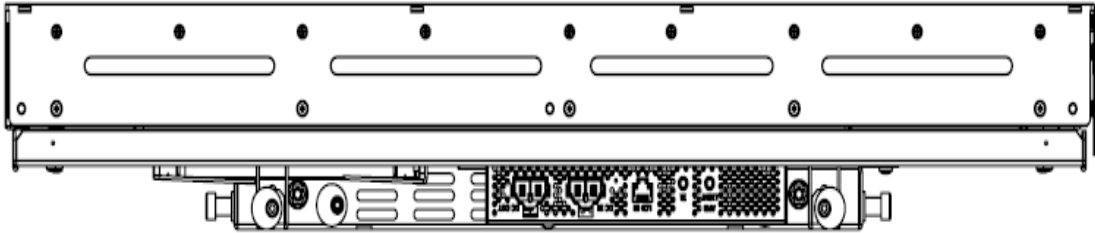
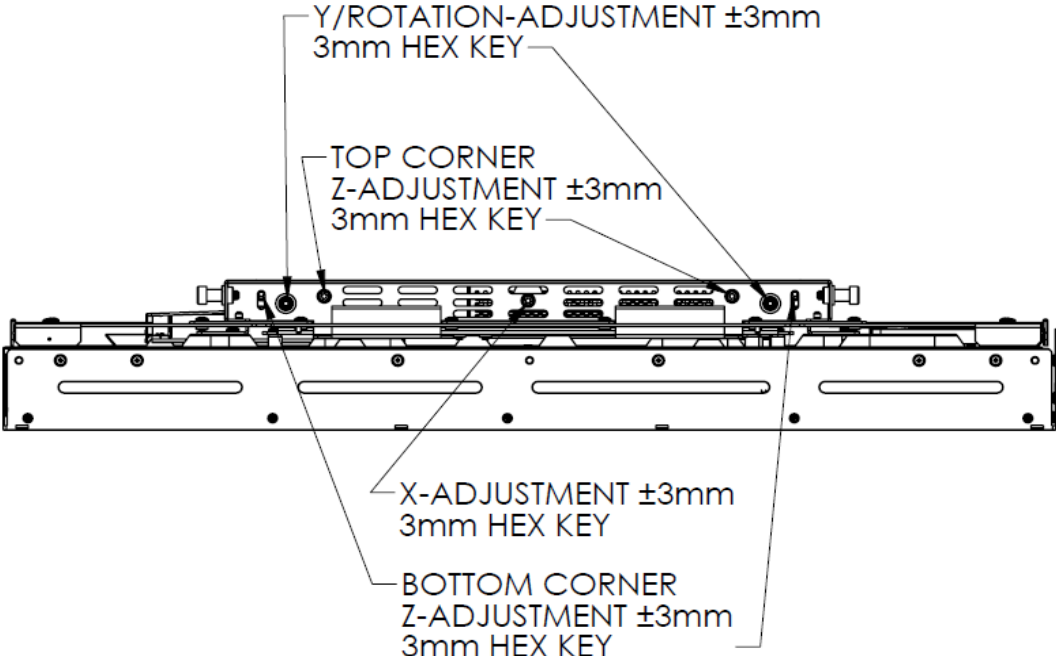

MX55HDS Front View – Portrait

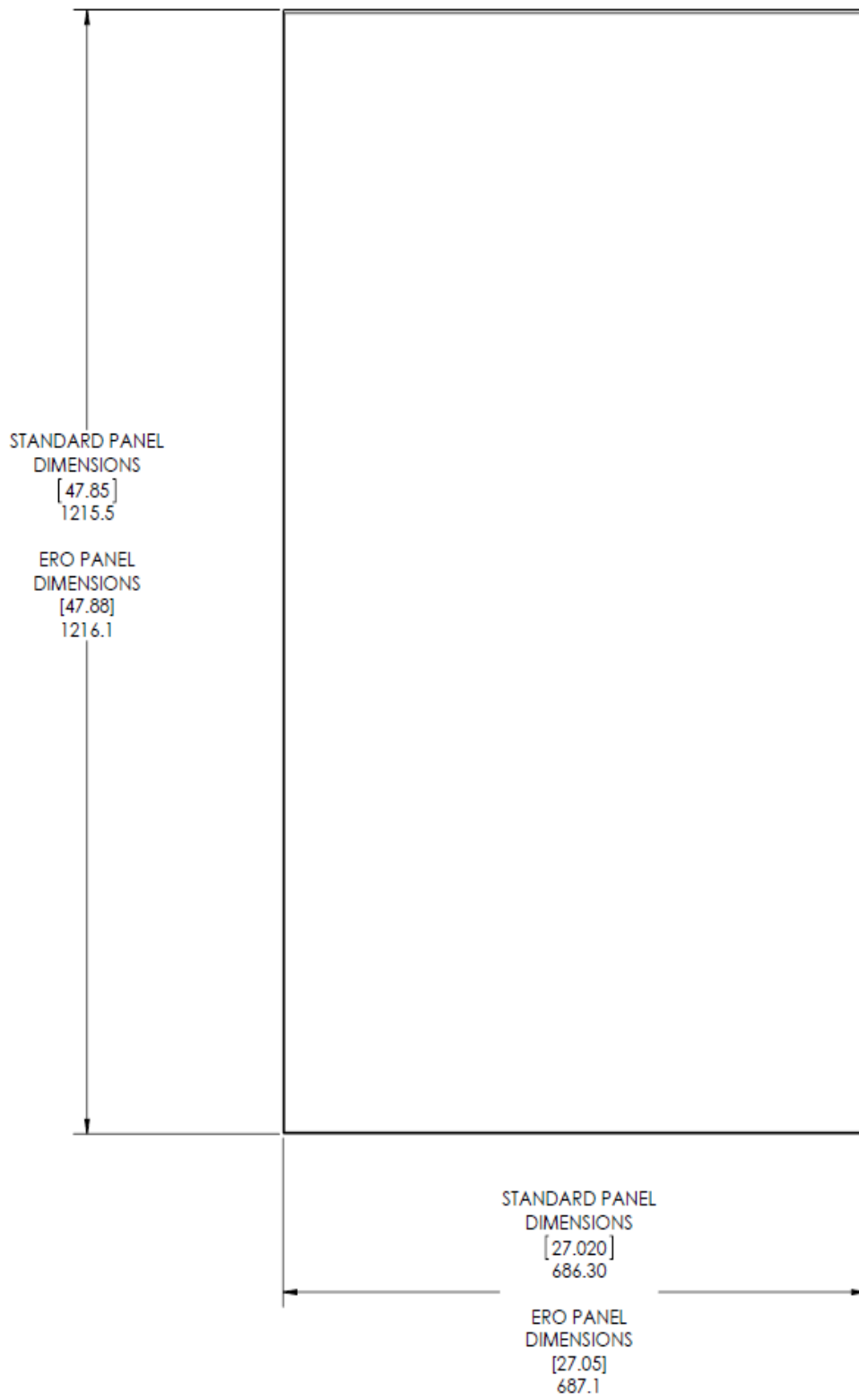

MX55HDS Rear View – Portrait

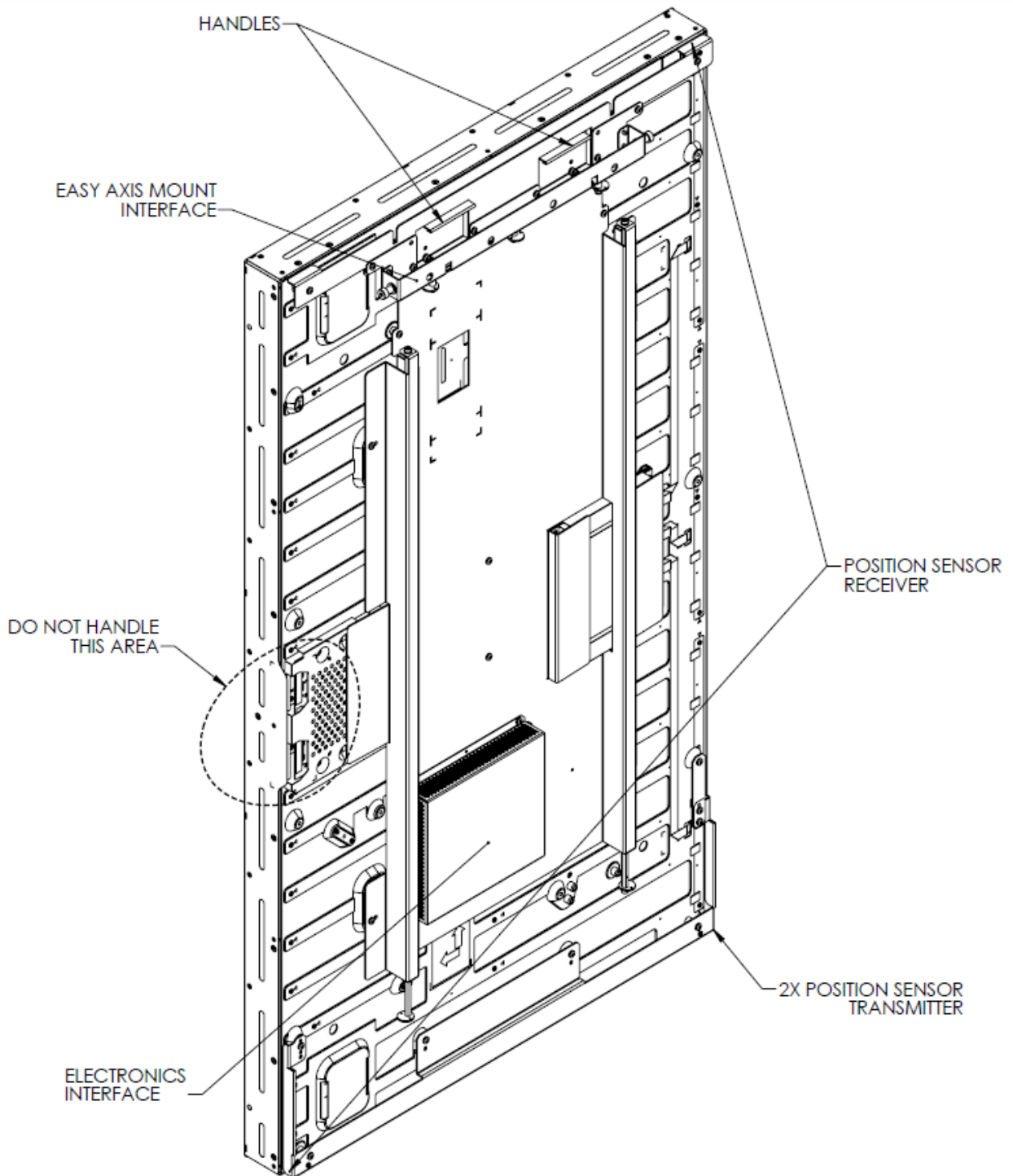

MX55HDS Side Views – Portrait

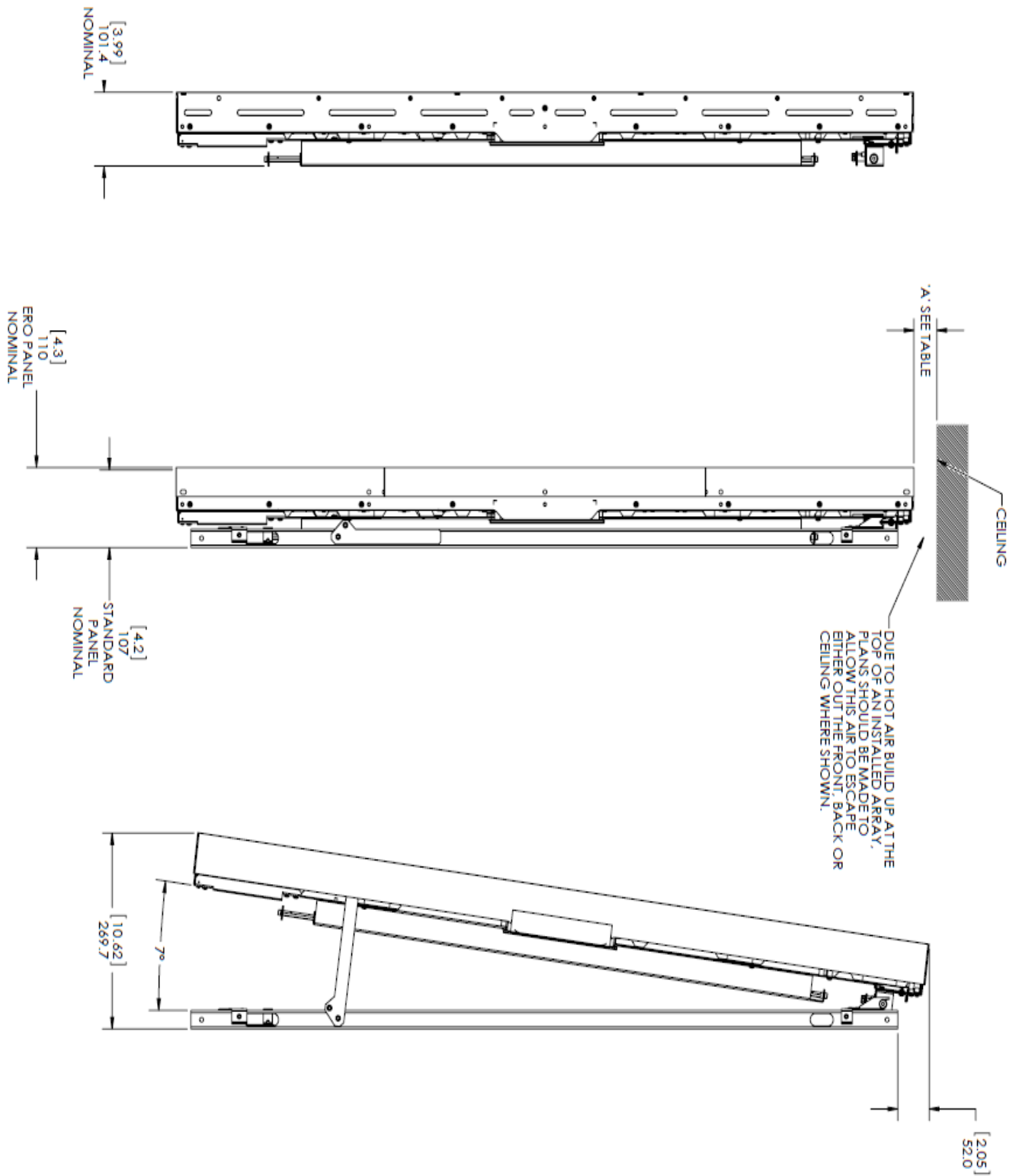

LX46HDS Dimensions – Landscape

LX46HDS Front, Top, and Bottom Views – Landscape

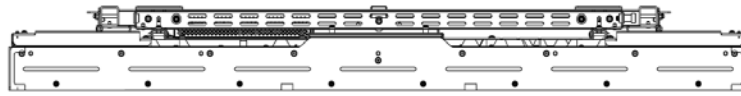

WITH MOUNT

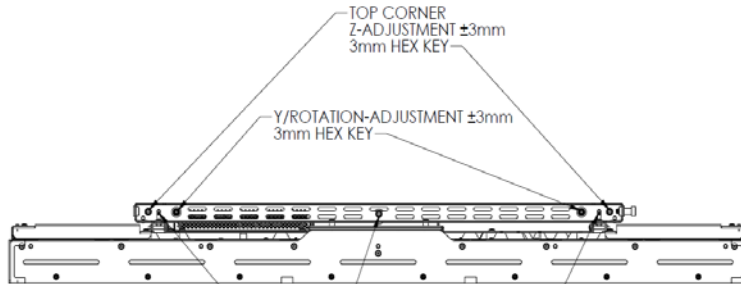

TOP CORNER
Z-ADJUSTMENT $\pm 3\text{mm}$
3mm HEX KEY

Y/ROTATION-ADJUSTMENT $\pm 3\text{mm}$
3mm HEX KEY

X-ADJUSTMENT $\pm 3\text{mm}$
3mm HEX KEY

BOTTOM CORNER
Z-ADJUSTMENT $\pm 3\text{mm}$
3mm HEX KEY

TOP VIEW

STANDARD PANEL
DIMENSIONS
[40.31]
1024.0

ERO PANEL
DIMENSIONS
[40.35]
1024.8

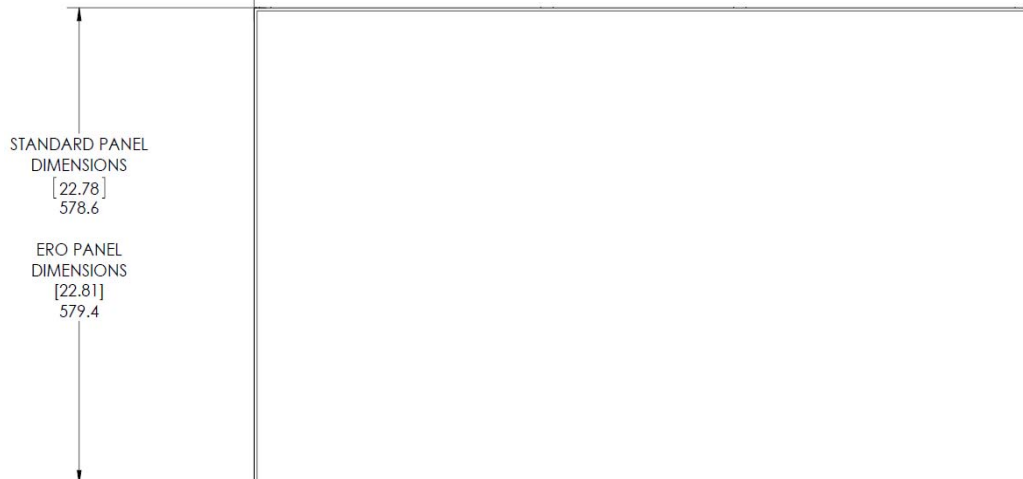

BOTTOM VIEW

LX46HDS Rear View – Landscape

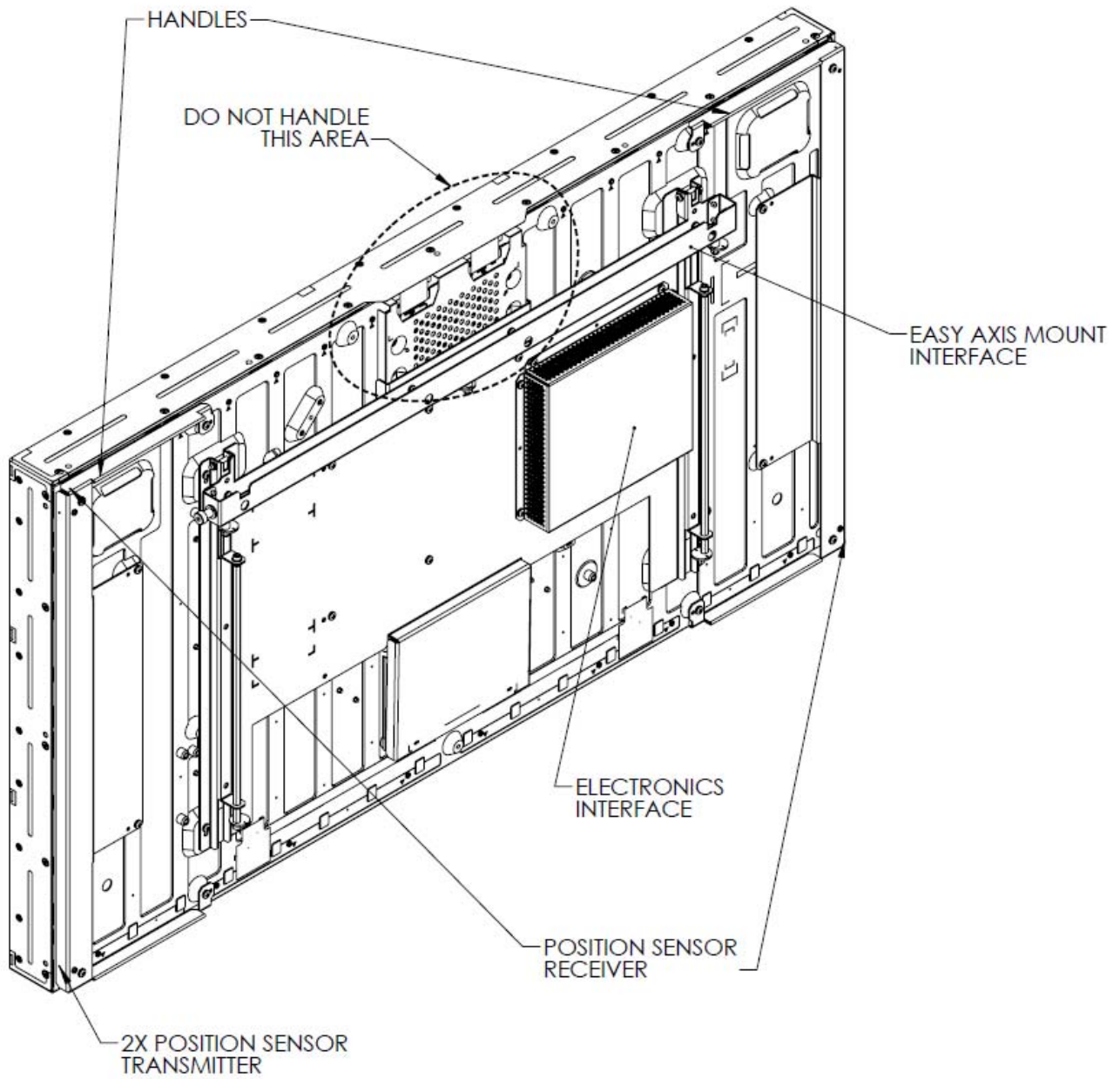

LX46HDS Side Views – Landscape

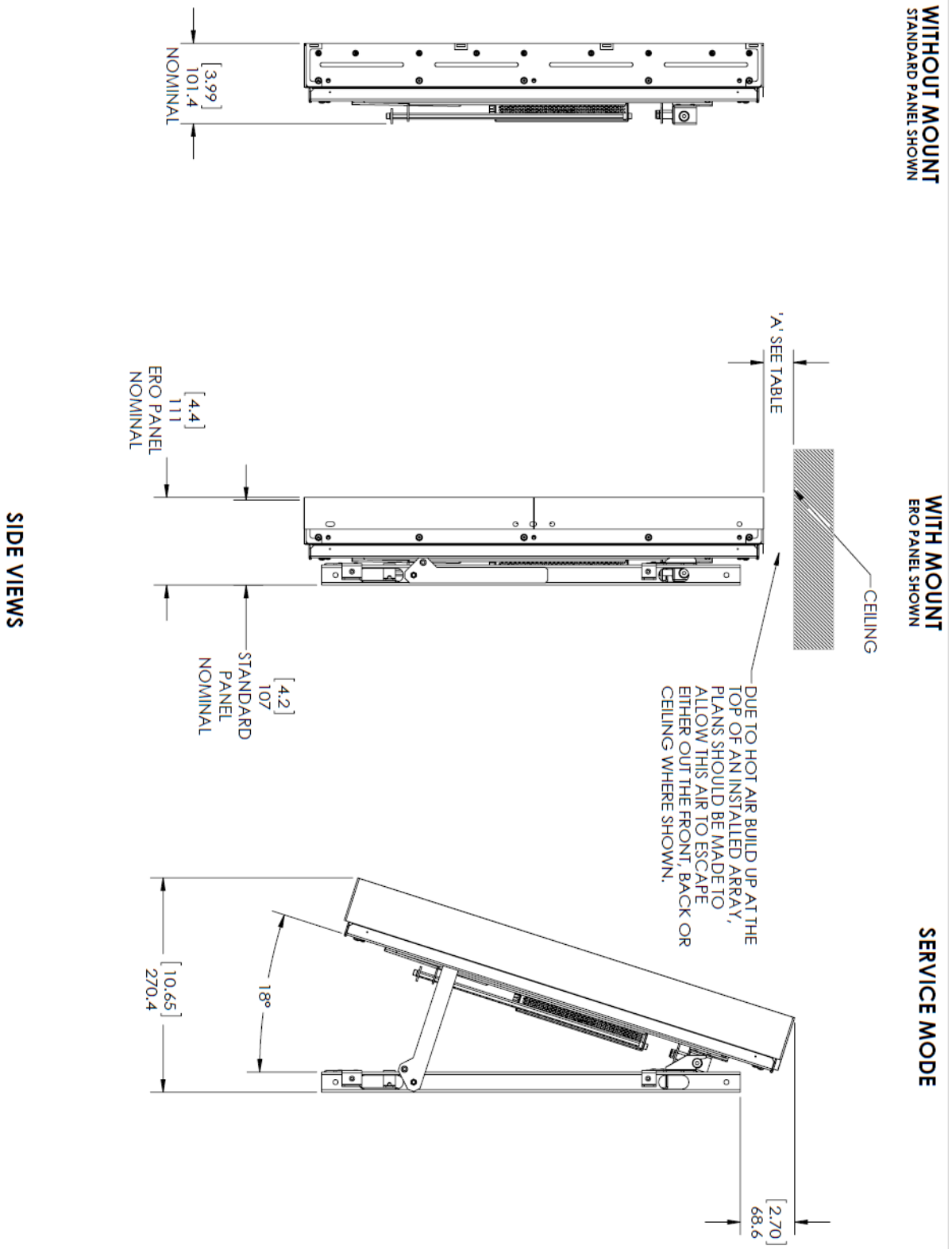

LX46HDS Dimensions – Portrait

LX46HDS Front and Side Views – Portrait

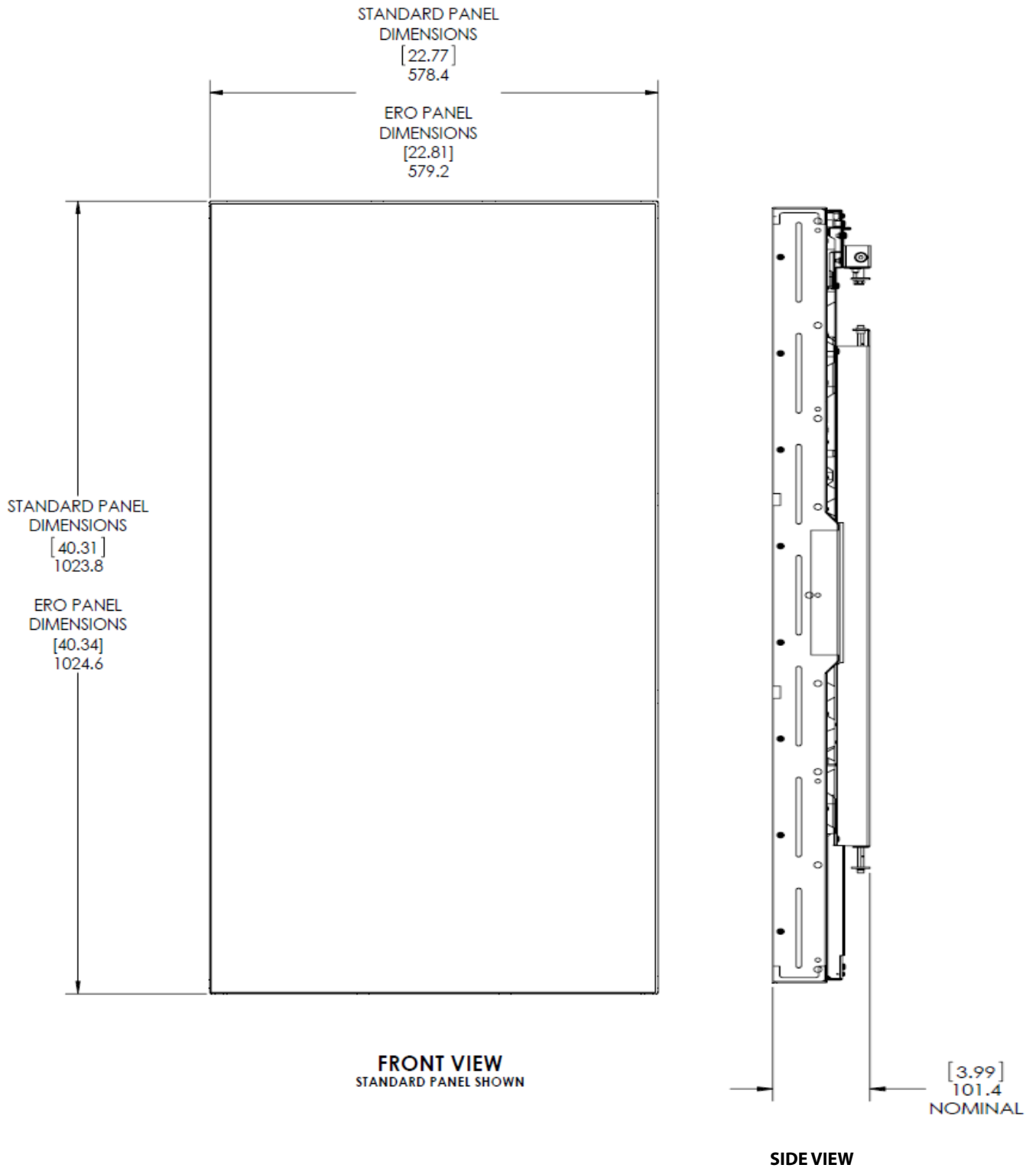

LX46HDS Rear View – Portrait

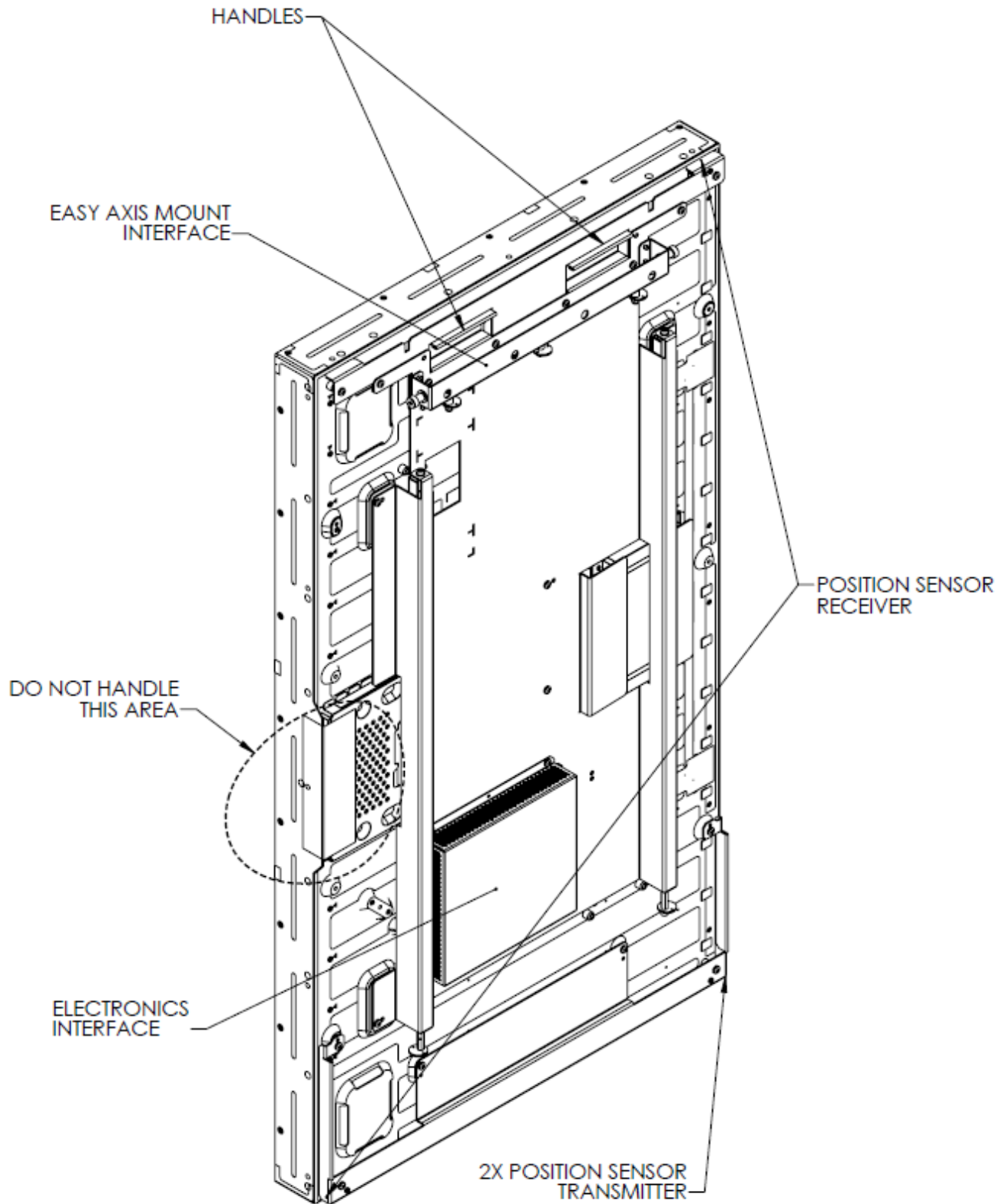

LX46HDS Side View – Portrait

WITHOUT MOUNT
STANDARD PANEL SHOWN

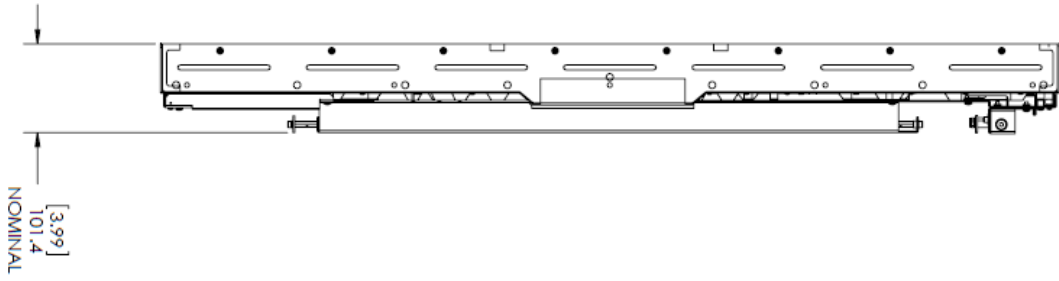

WITH MOUNT
ERO PANEL SHOWN

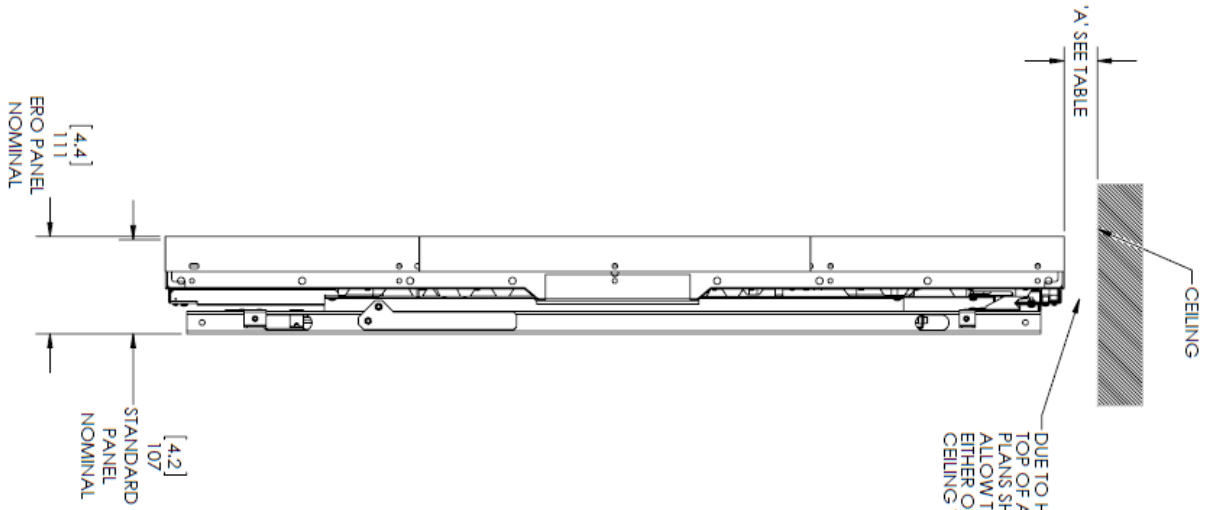

SERVICE MODE

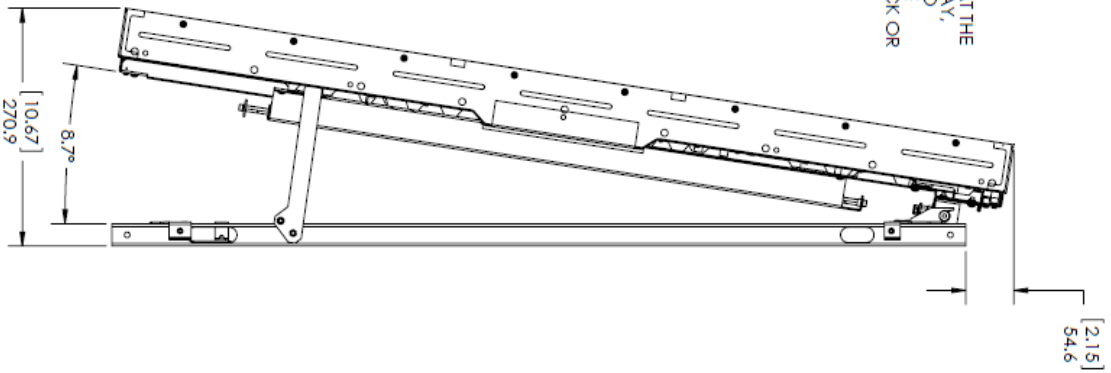

SIDE VIEWS

LX55HDS Dimensions – Landscape

LX55HDS Front, Top, and Bottom Views – Landscape

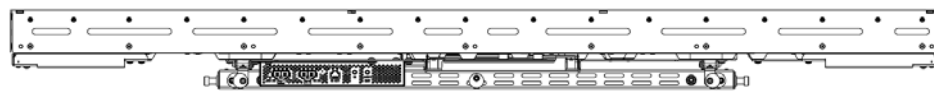
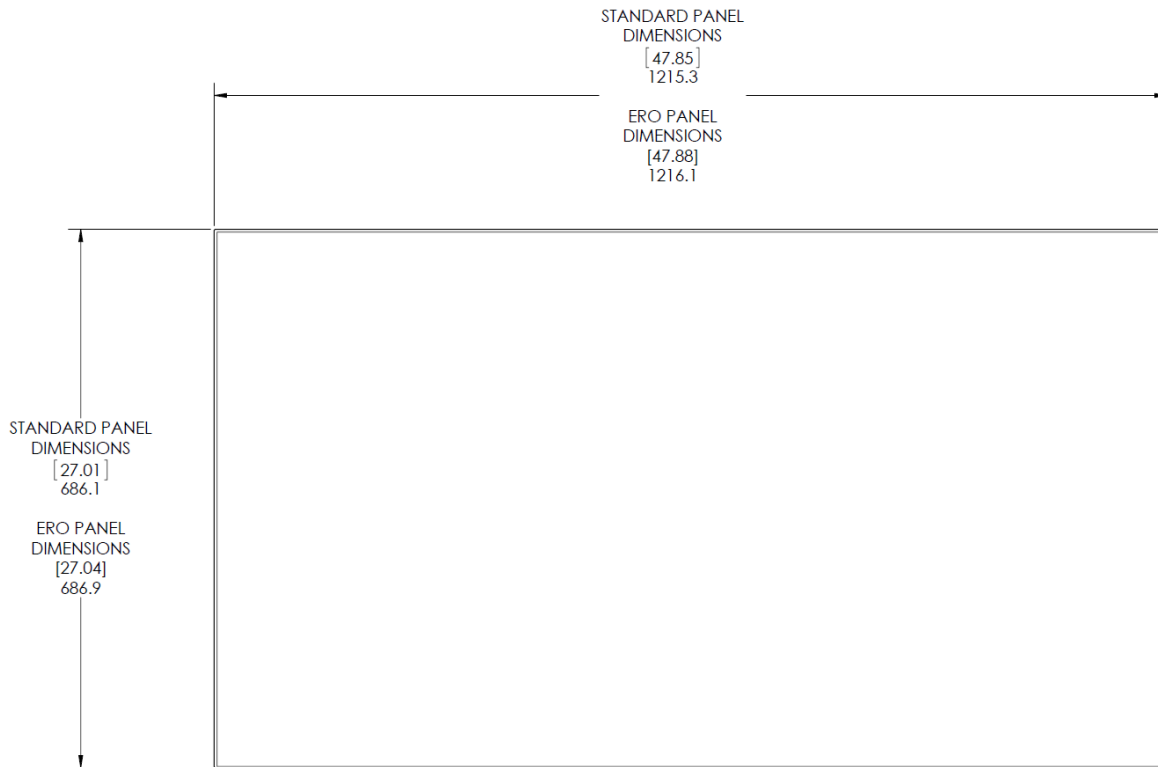
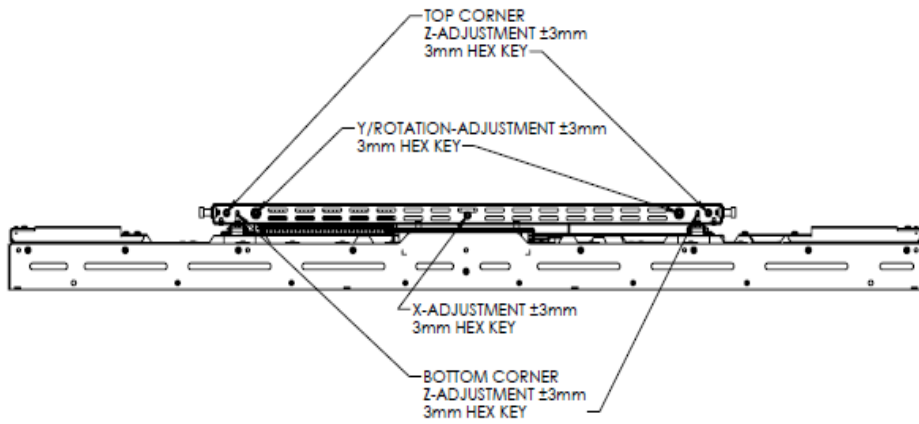
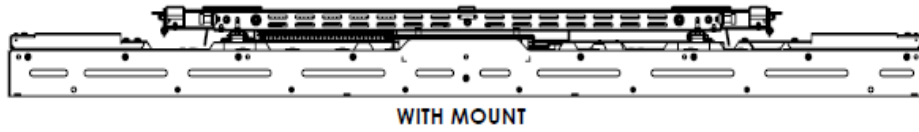

LX55HDS Rear View – Landscape

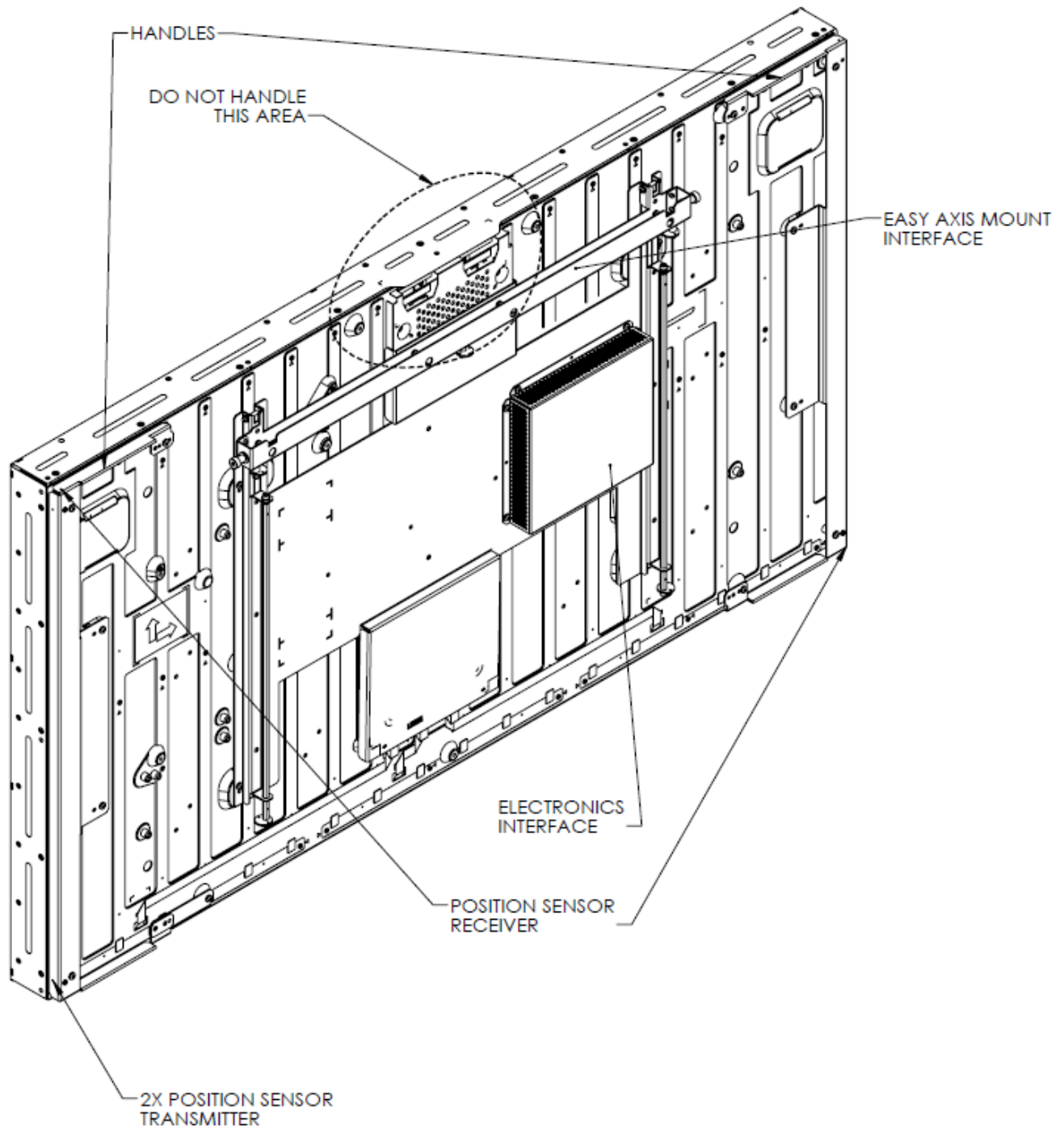

LX55HDS Side View – Landscape

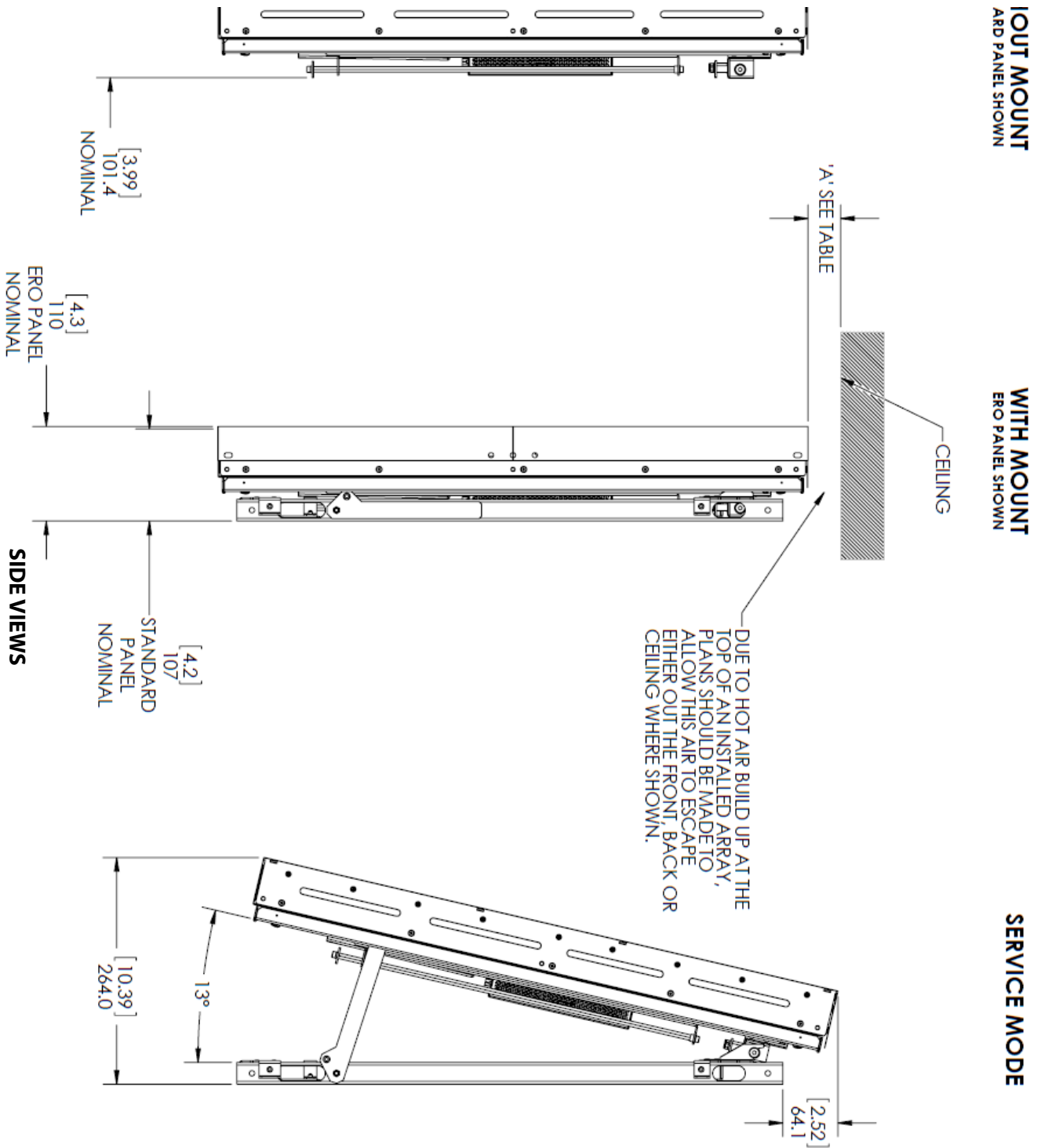

LX55HDS Dimensions – Portrait

LX55HDS Front View – Portrait

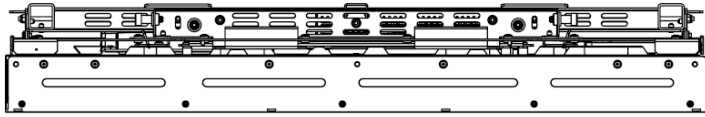

WITH MOUNT

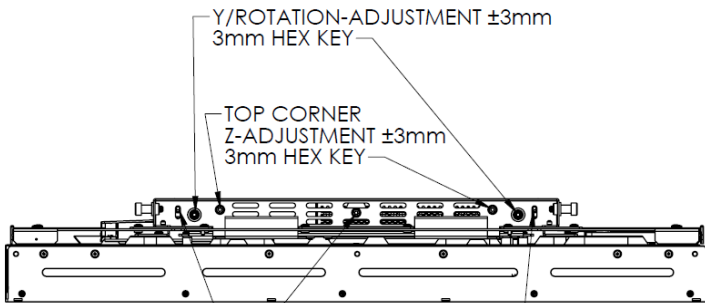

Y/ROTATION-ADJUSTMENT ±3mm
3mm HEX KEY

TOP CORNER
Z-ADJUSTMENT ±3mm
3mm HEX KEY

X-ADJUSTMENT ±3mm
3mm HEX KEY

BOTTOM CORNER
Z-ADJUSTMENT ±3mm
3mm HEX KEY

TOP VIEW

STANDARD PANEL
DIMENSIONS
[47.85]
1215.5

ERO PANEL
DIMENSIONS
[47.88]
1216.1

BOTTOM VIEW

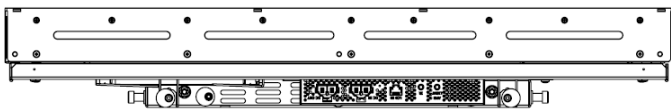

STANDARD PANEL
DIMENSIONS
[27.020]
686.30

ERO PANEL
DIMENSIONS
[27.05]
687.1

LX55HDS Rear View – Portrait

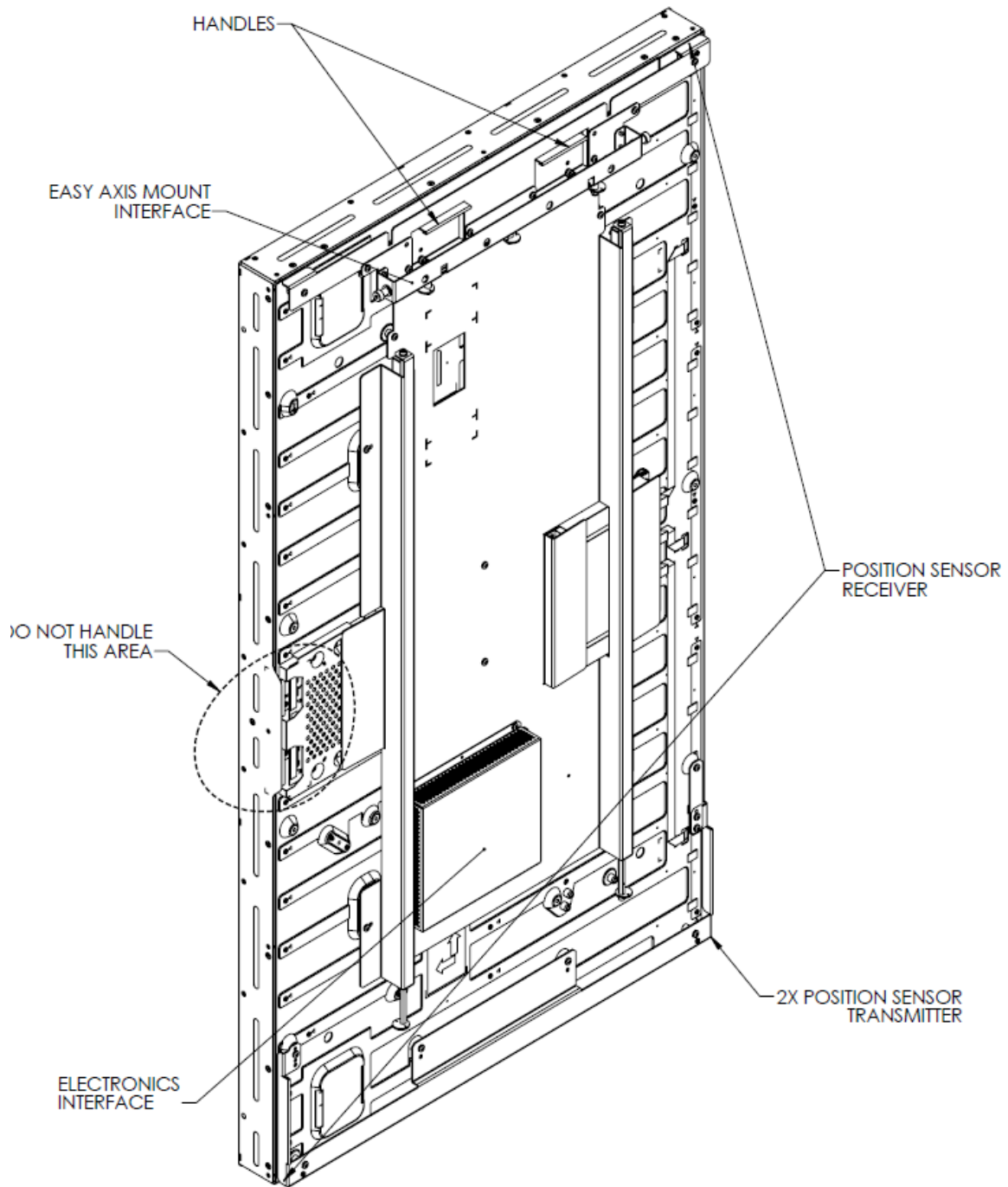

LX55HDS Side View – Portrait

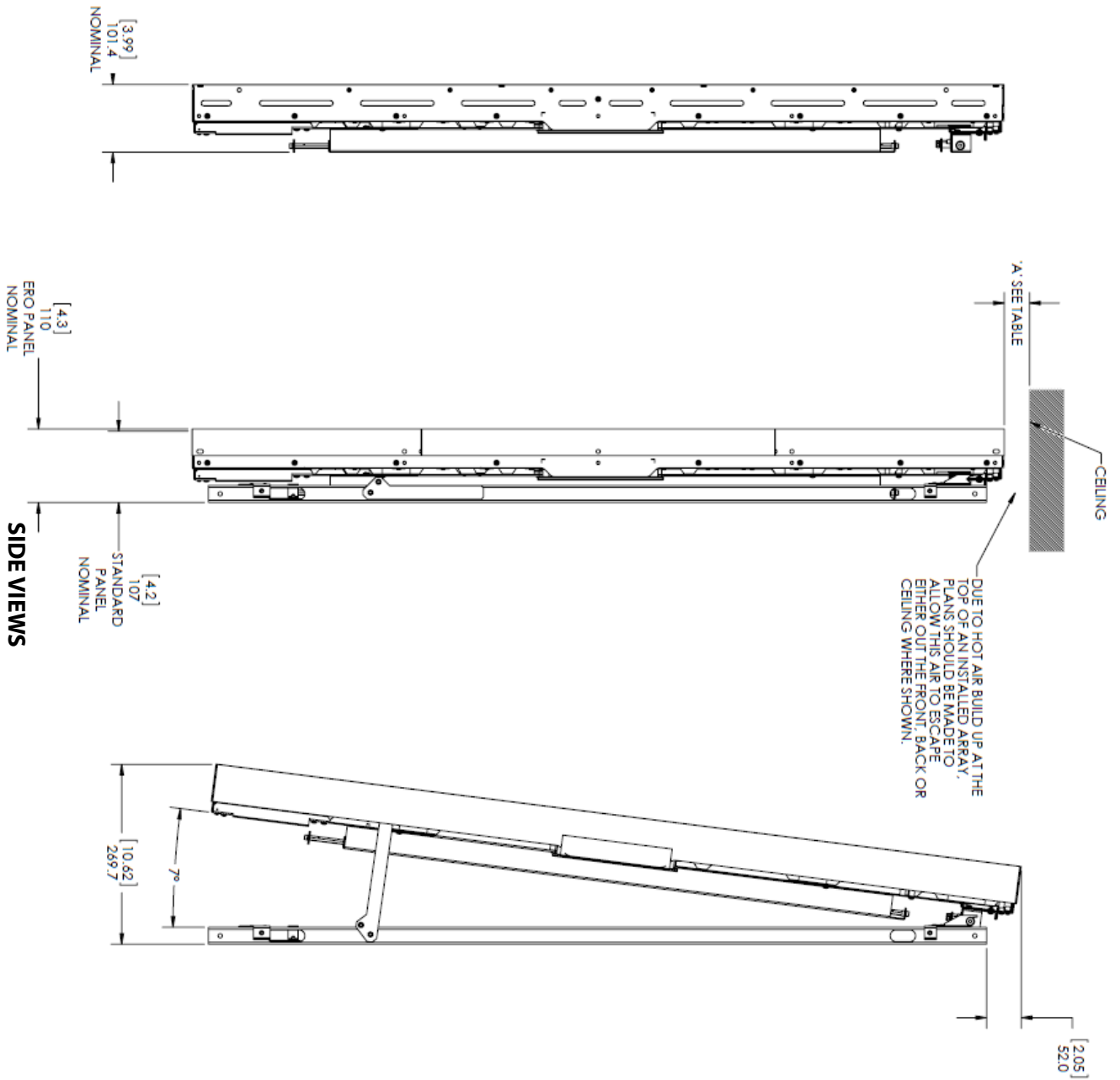

LX46S-3D Dimensions Landscape (only)

Note: LX46S-3D is mounted in landscape orientation only.

LX46S-3D Front, Top, and Bottom Views

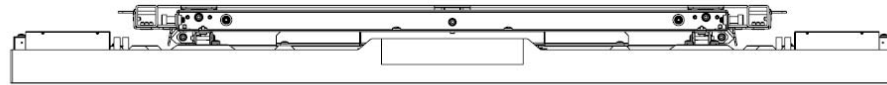

WITH MOUNT

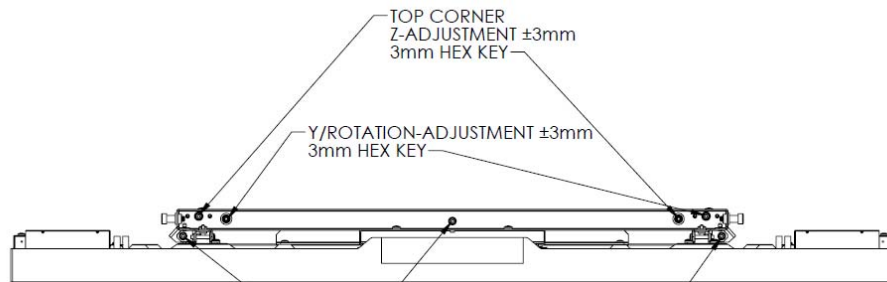

TOP VIEW

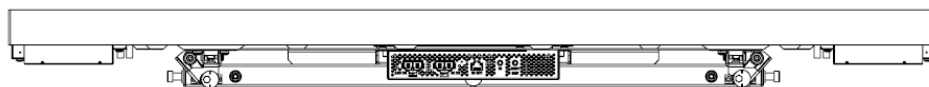
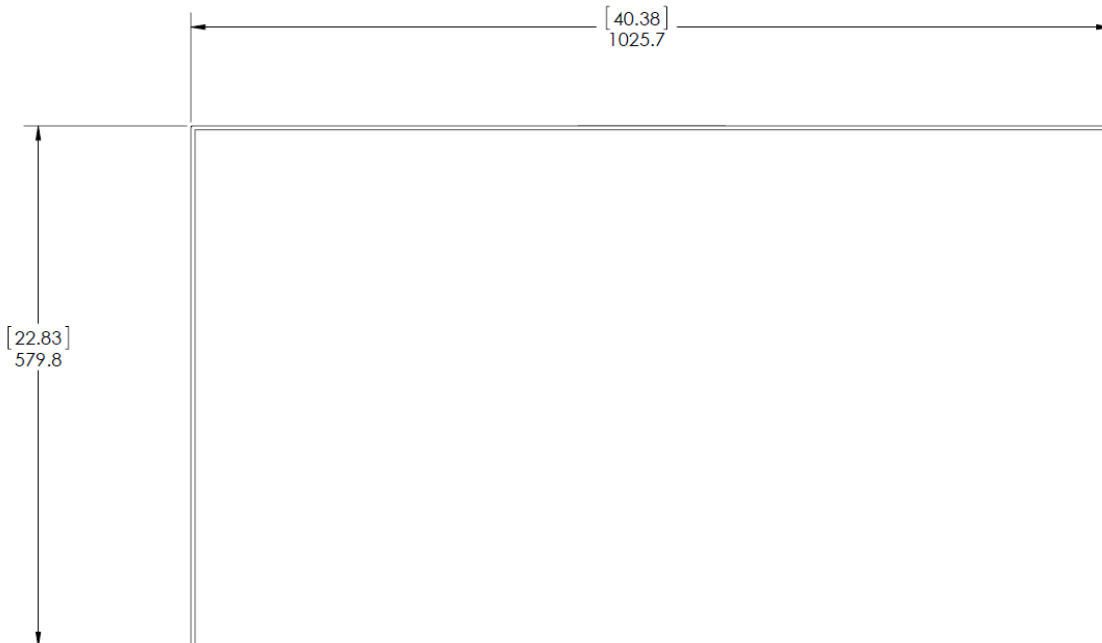

BOTTOM VIEW

LX46S-3D Rear View

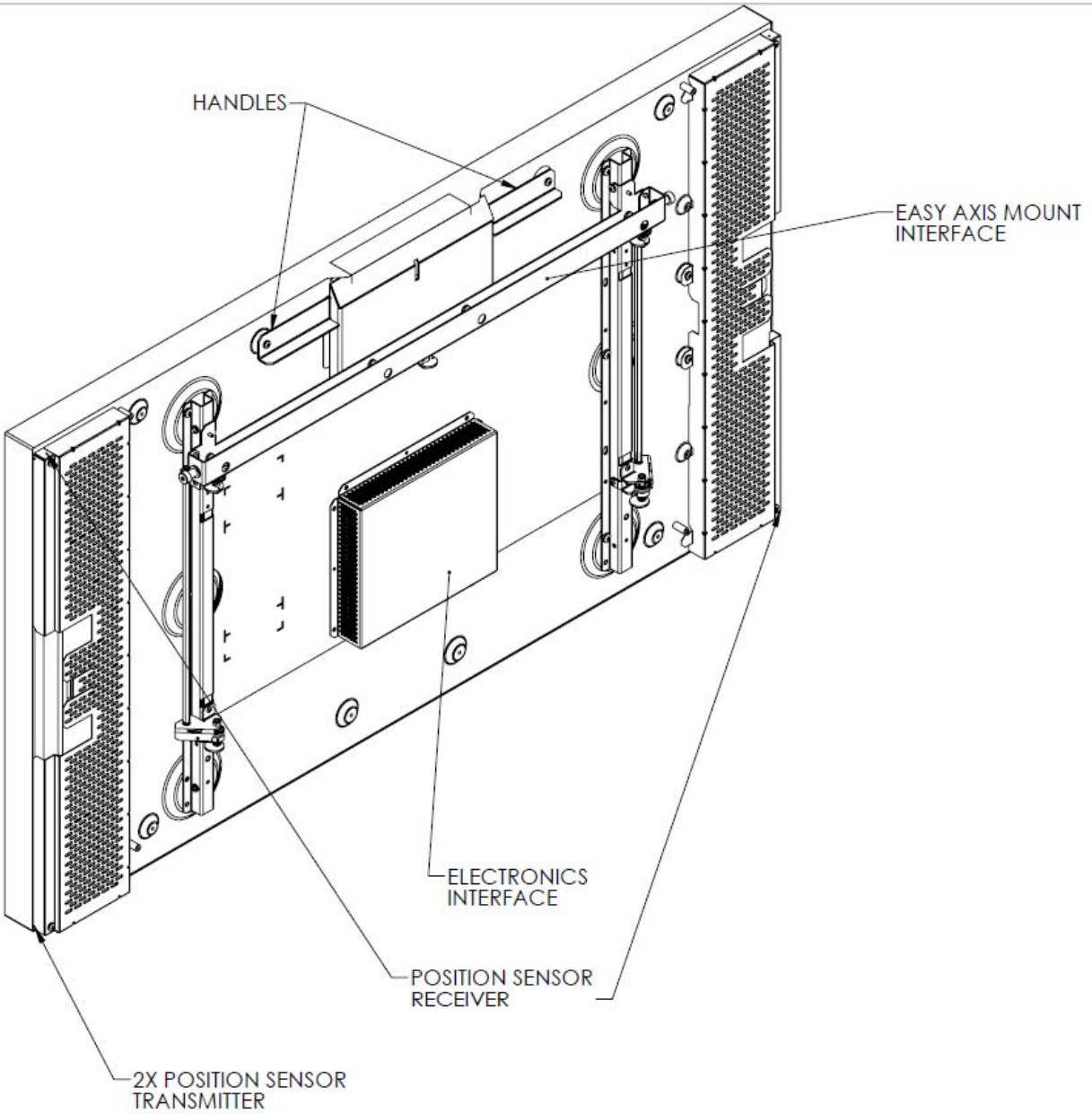

LX46S-3D Side Views

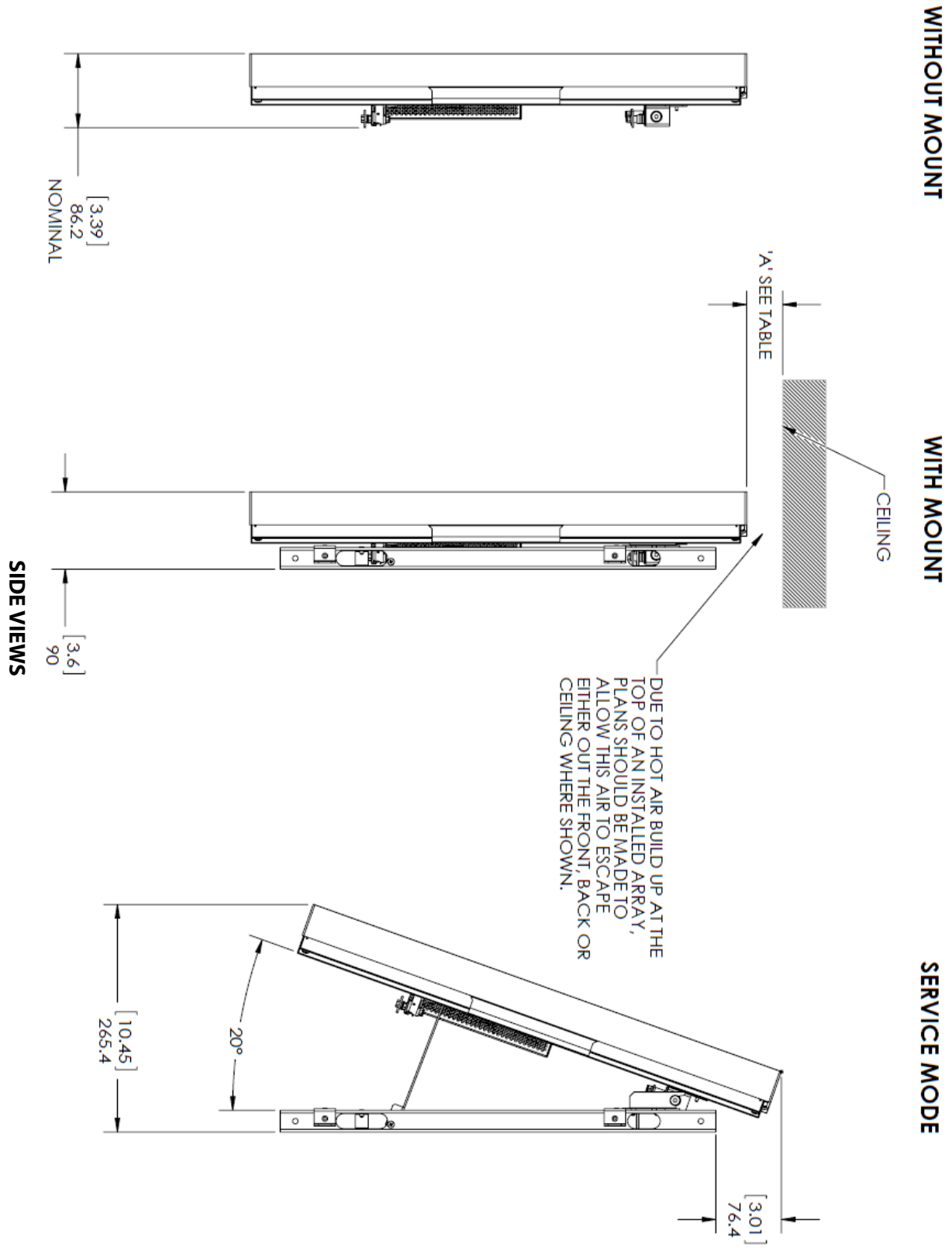

MX46HDU Dimensions – Landscape

MX46HDU Top, Front, and Bottom Views – Landscape

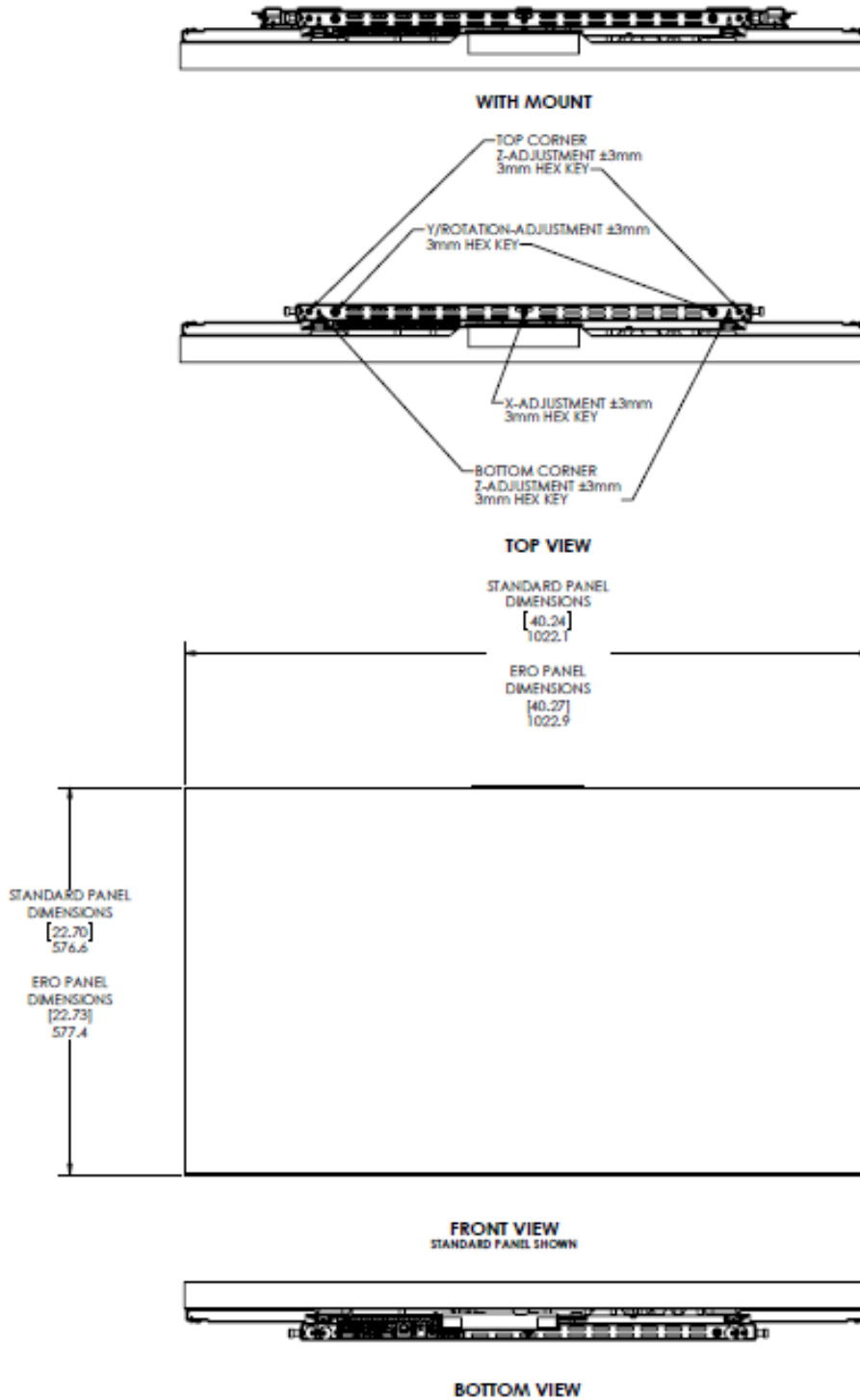

MX46HDU Rear View – Landscape

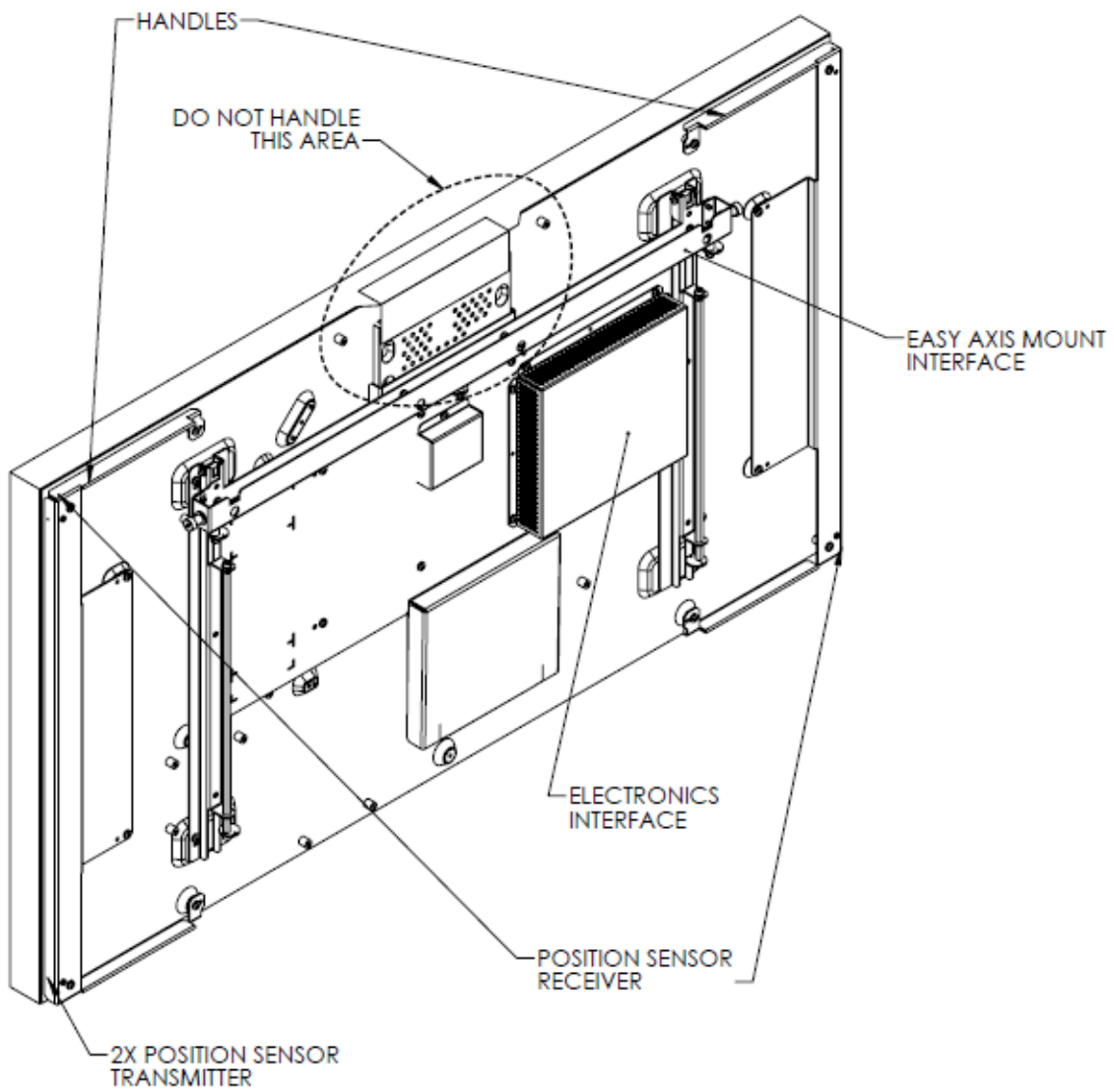

MX46HDU Side Views – Landscape

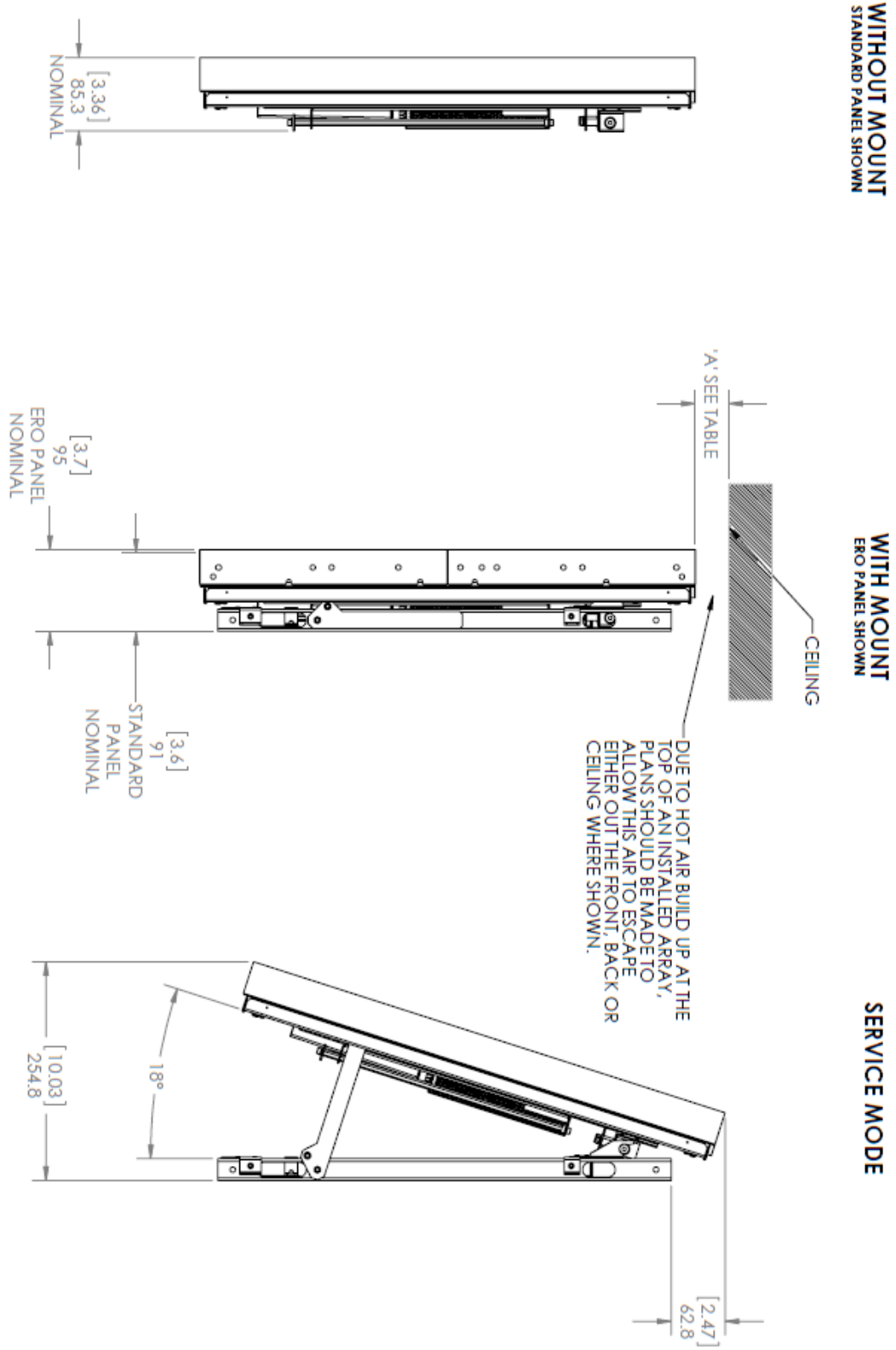

MX46HDU Dimensions – Portrait

MX46HDU Top and Bottom Views – Portrait

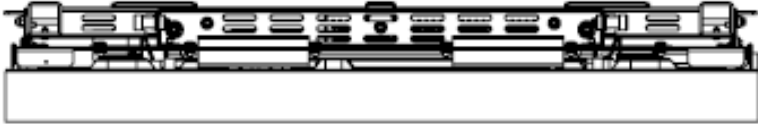

WITH MOUNT

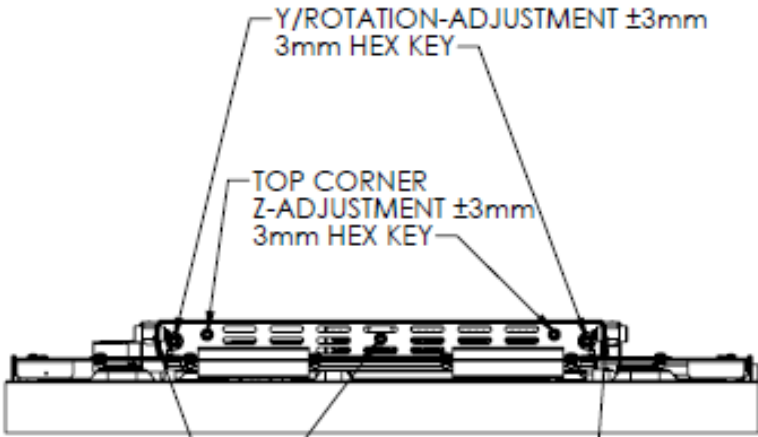

TOP VIEW



BOTTOM VIEW

MX46HDU Front View – Portrait

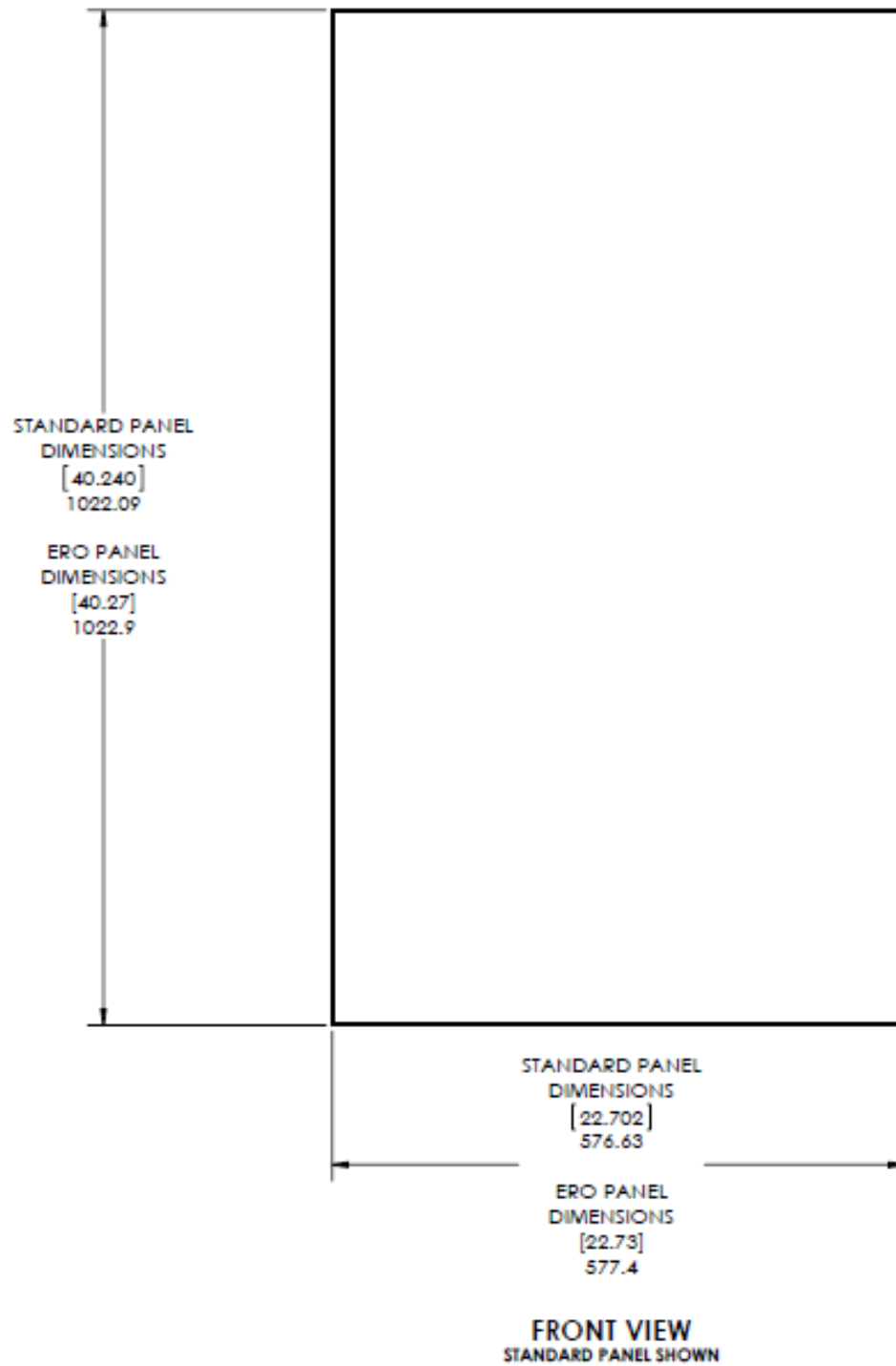

MX46HDU Rear View – Portrait

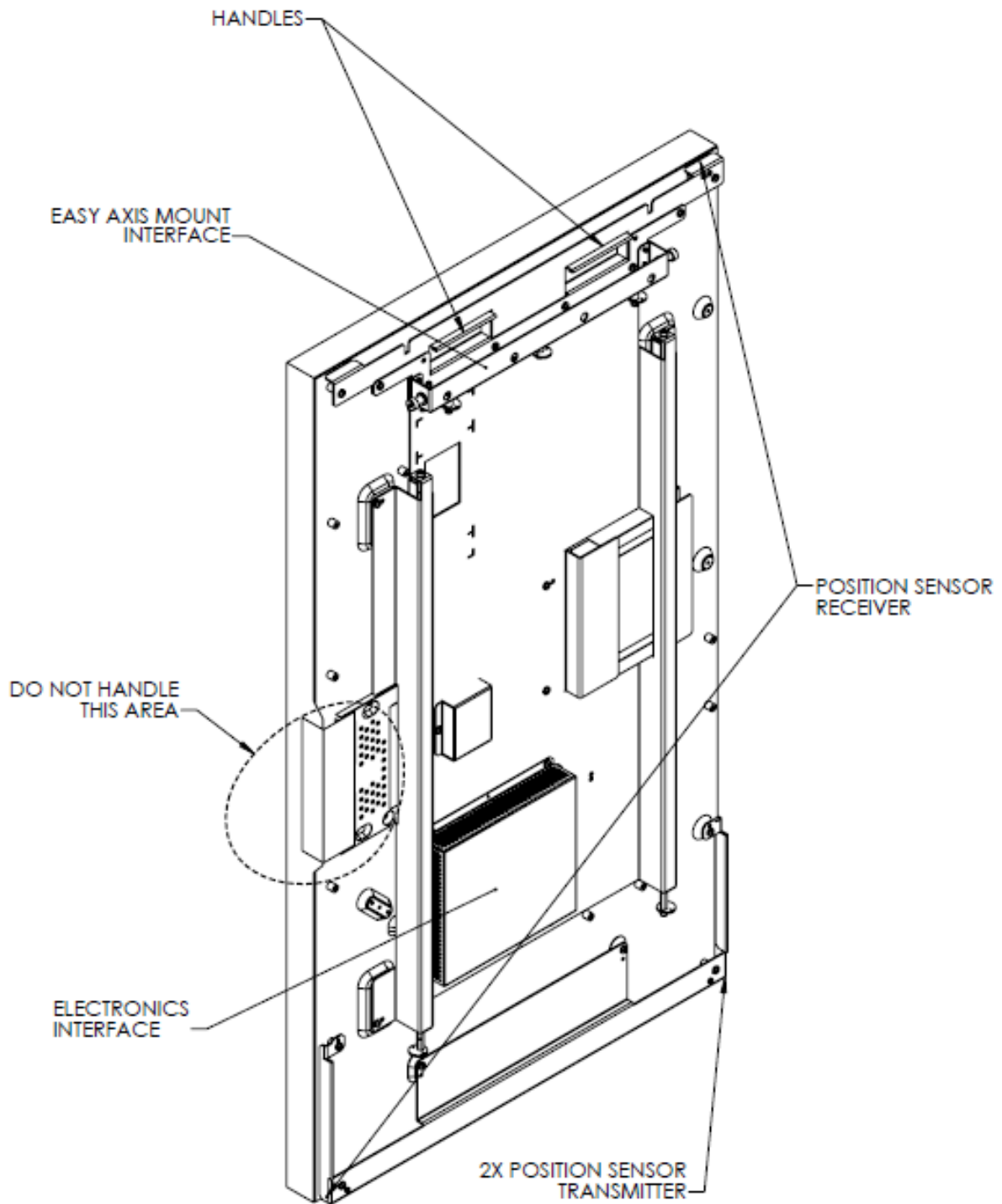

MX46HDU Side Views – Portrait

WITHOUT MOUNT
STANDARD PANEL SHOWN

WITH MOUNT
ERO PANEL SHOWN

SERVICE MODE

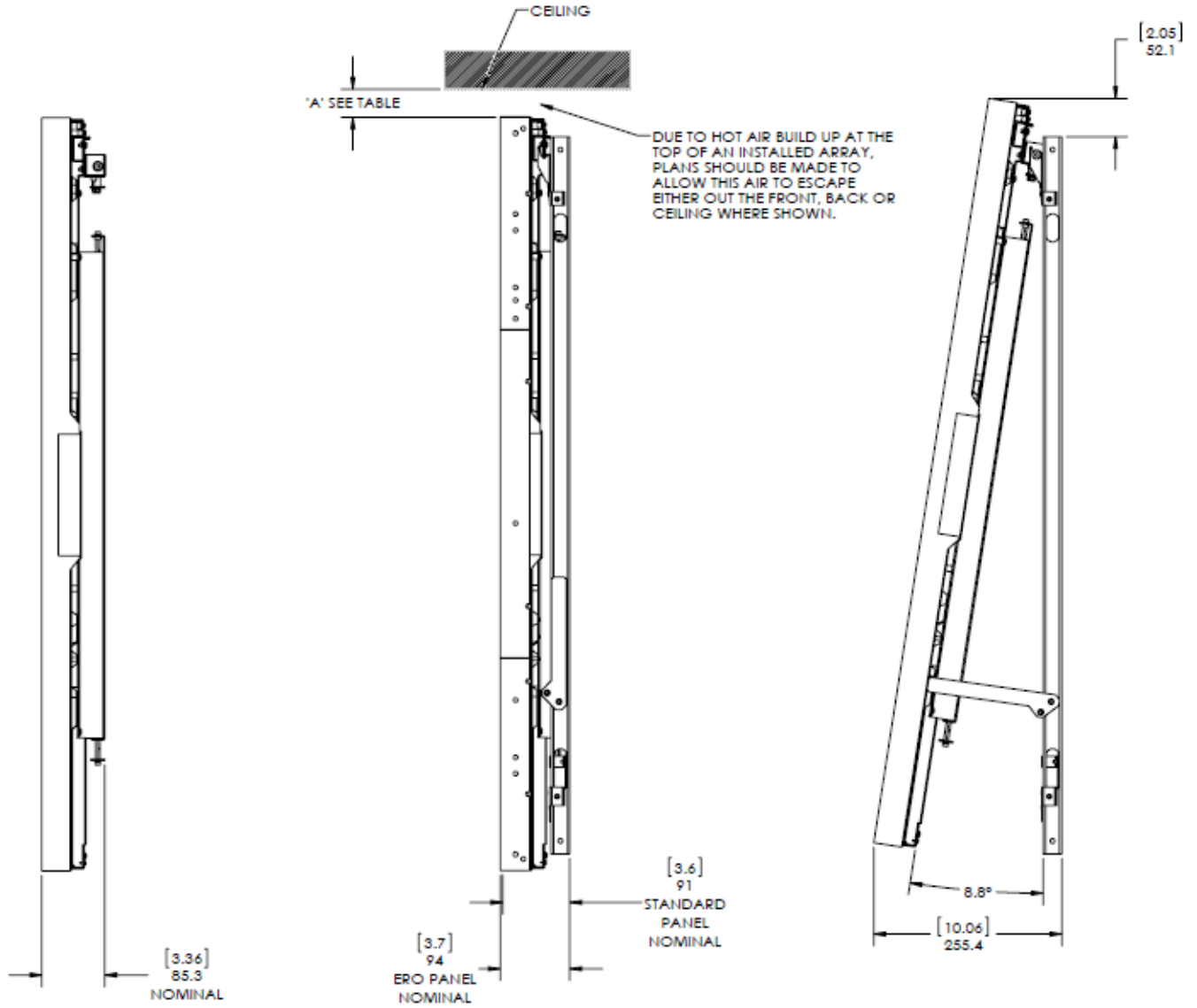

SIDE VIEWS

LX/MX55HDU Dimensions – Landscape

LX/MX55HDU Top, Front, and Bottom Views – Landscape

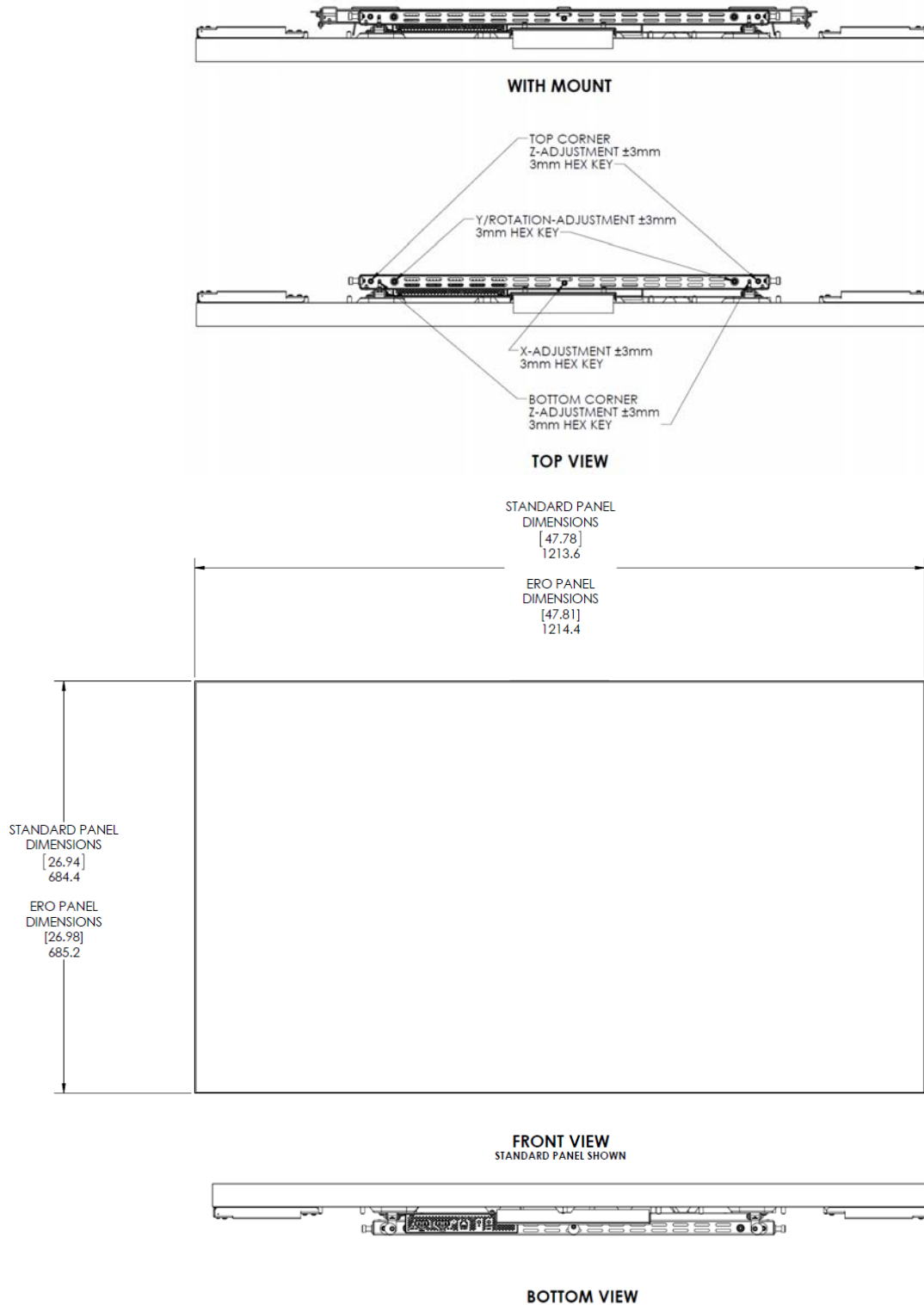

LX/MX55HDU Rear View – Landscape

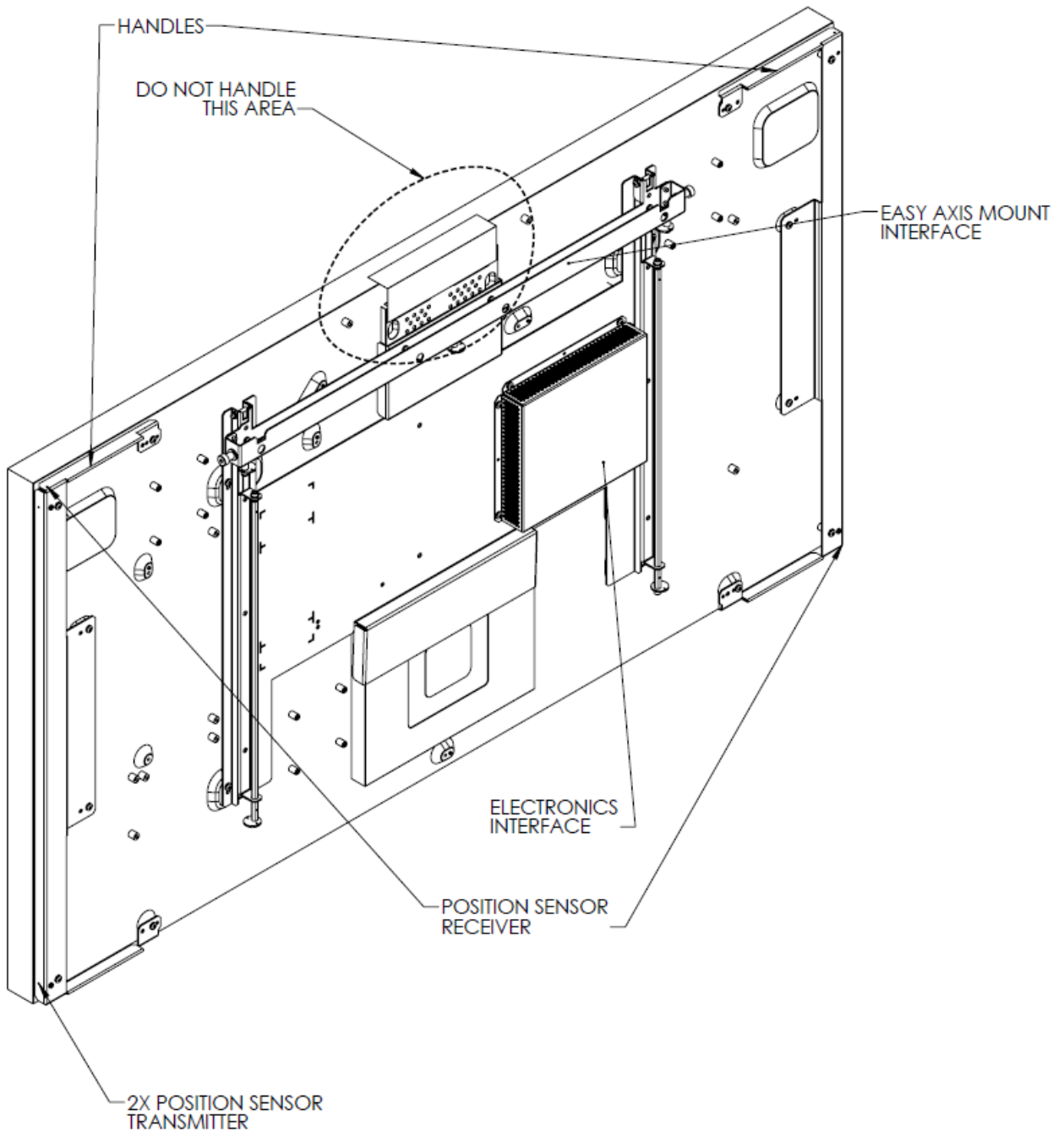

LX/MX55HDU Side Views – Landscape

WITHOUT MOUNT
STANDARD PANEL SHOWN

WITH MOUNT
ERO PANEL SHOWN

SERVICE MODE

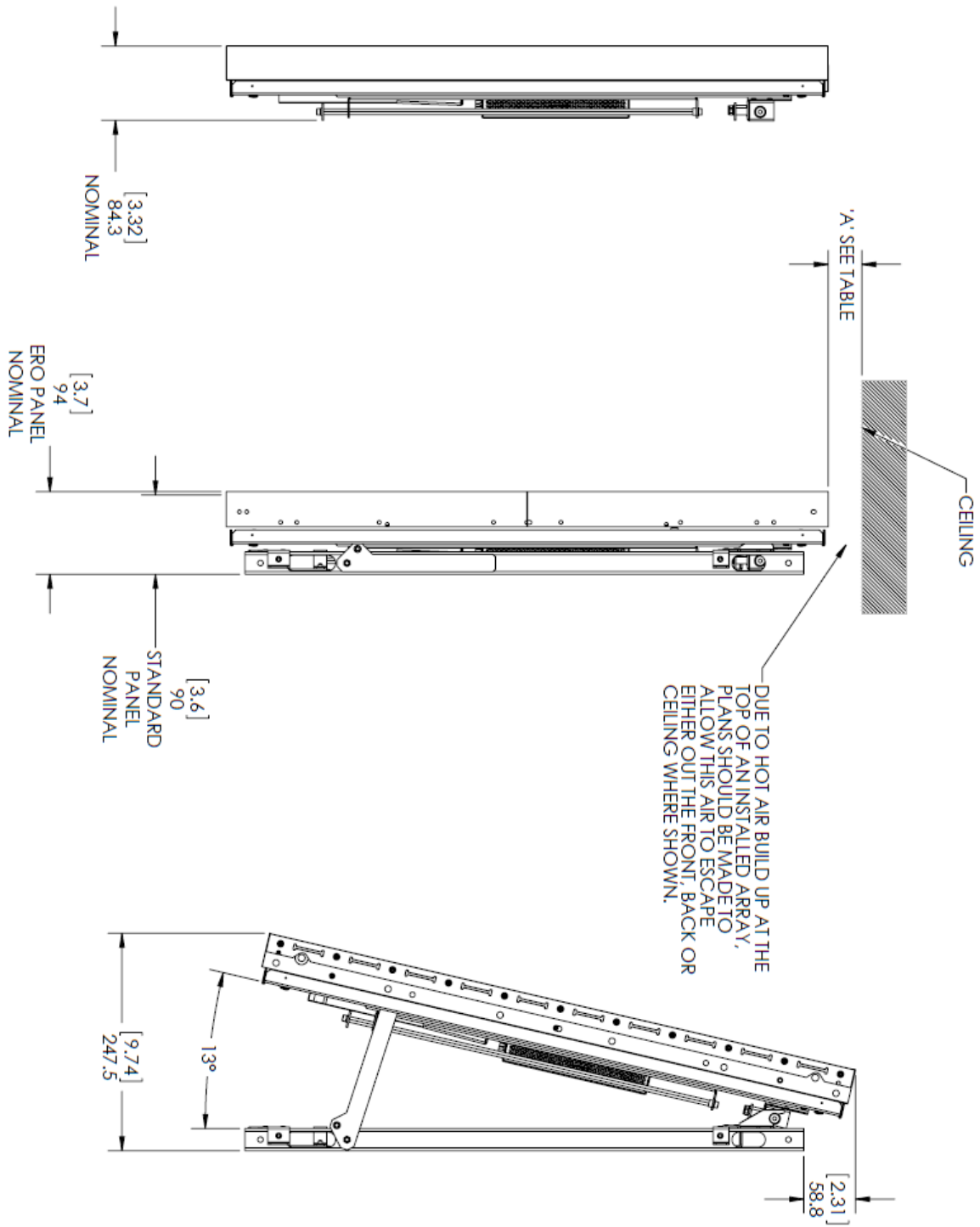

SIDE VIEWS

LX/MX55HDU Dimensions – Portrait

LX/MX55HDU Top and Bottom Views – Portrait

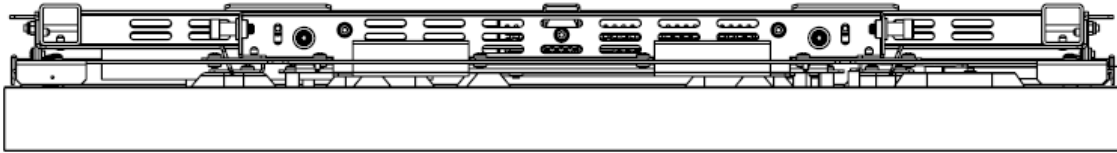

WITH MOUNT

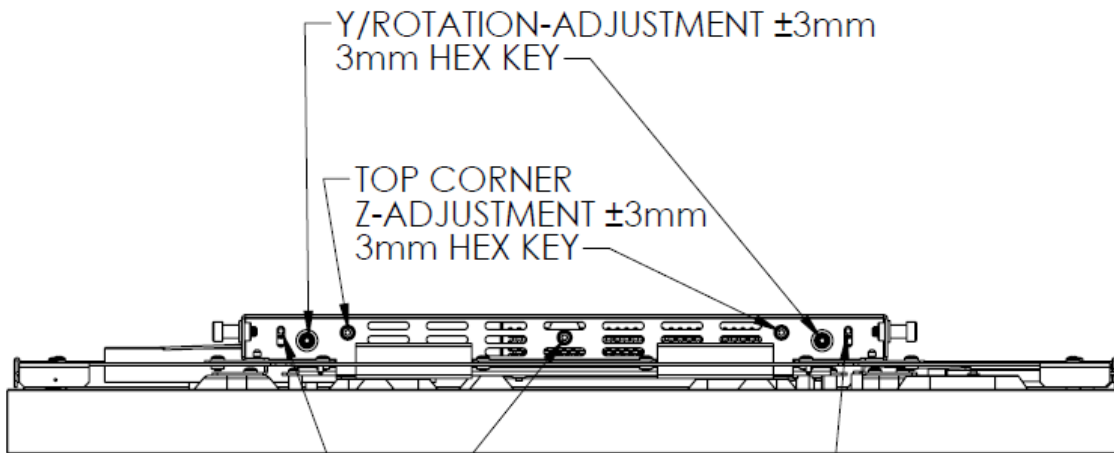

Y/ROTATION-ADJUSTMENT $\pm 3\text{mm}$
3mm HEX KEY

TOP CORNER
Z-ADJUSTMENT $\pm 3\text{mm}$
3mm HEX KEY

X-ADJUSTMENT $\pm 3\text{mm}$
3mm HEX KEY

BOTTOM CORNER
Z-ADJUSTMENT $\pm 3\text{mm}$
3mm HEX KEY

TOP VIEW

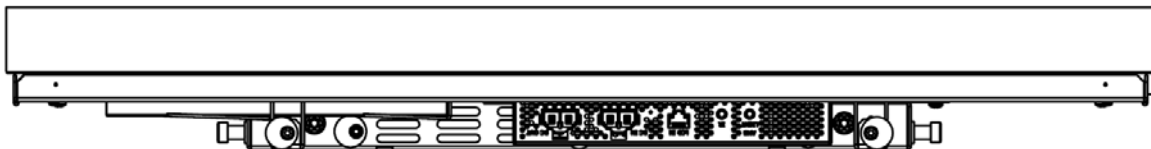

BOTTOM VIEW

LX/MX55HDU Front View – Portrait

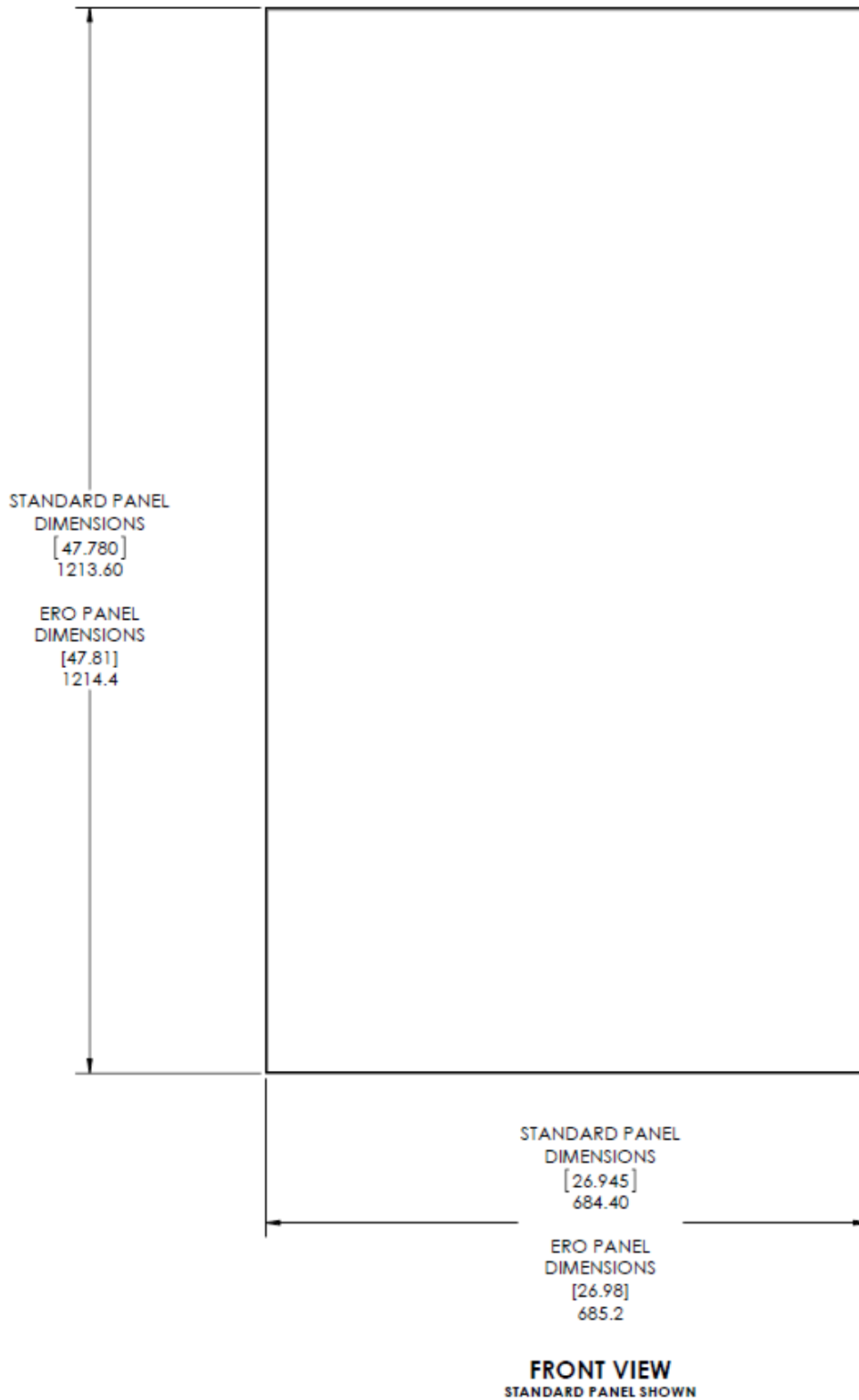

LX/MX55HDU Side Views – Portrait

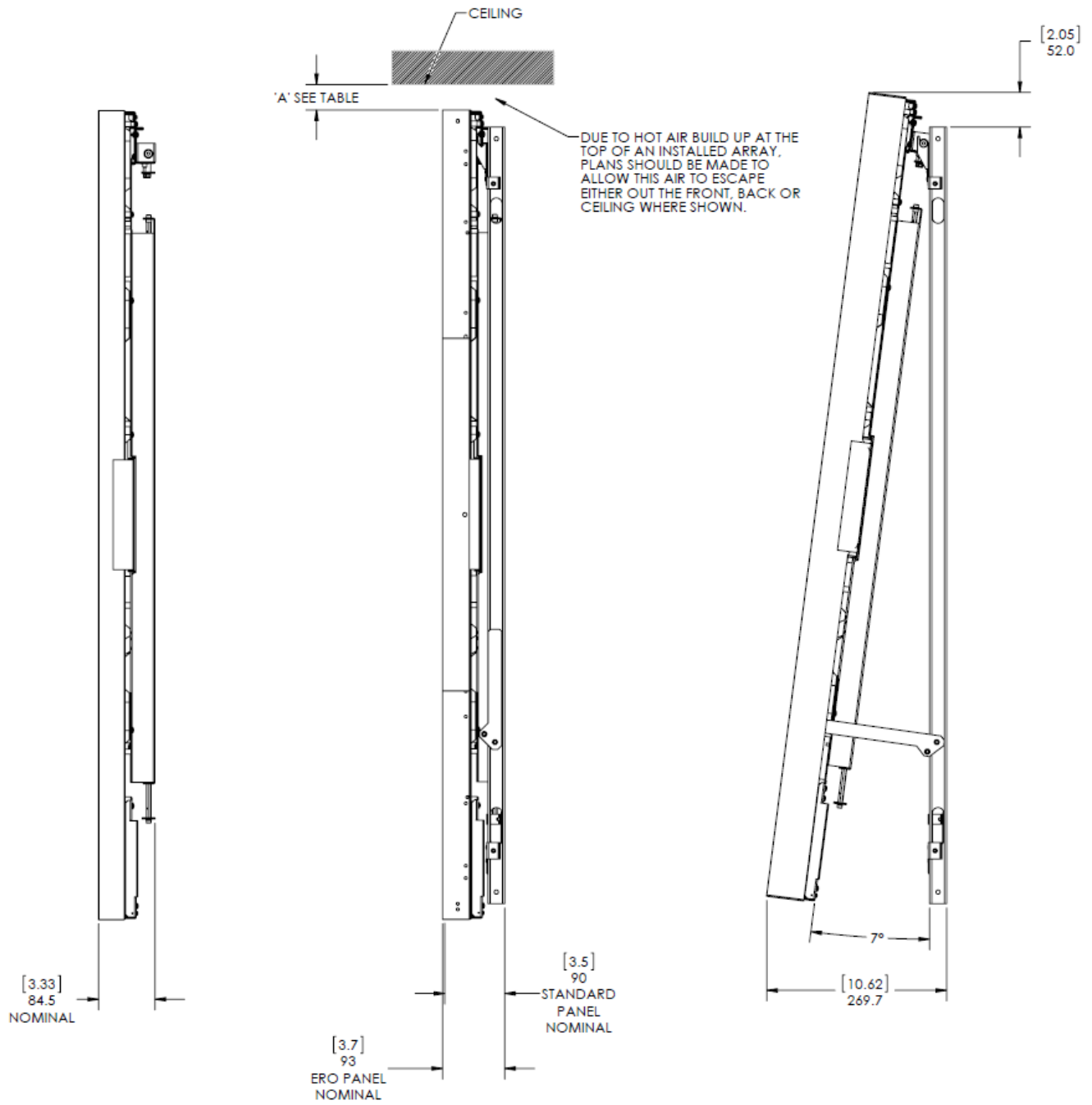

SIDE VIEWS

LX/MX55HDU Rear View – Portrait

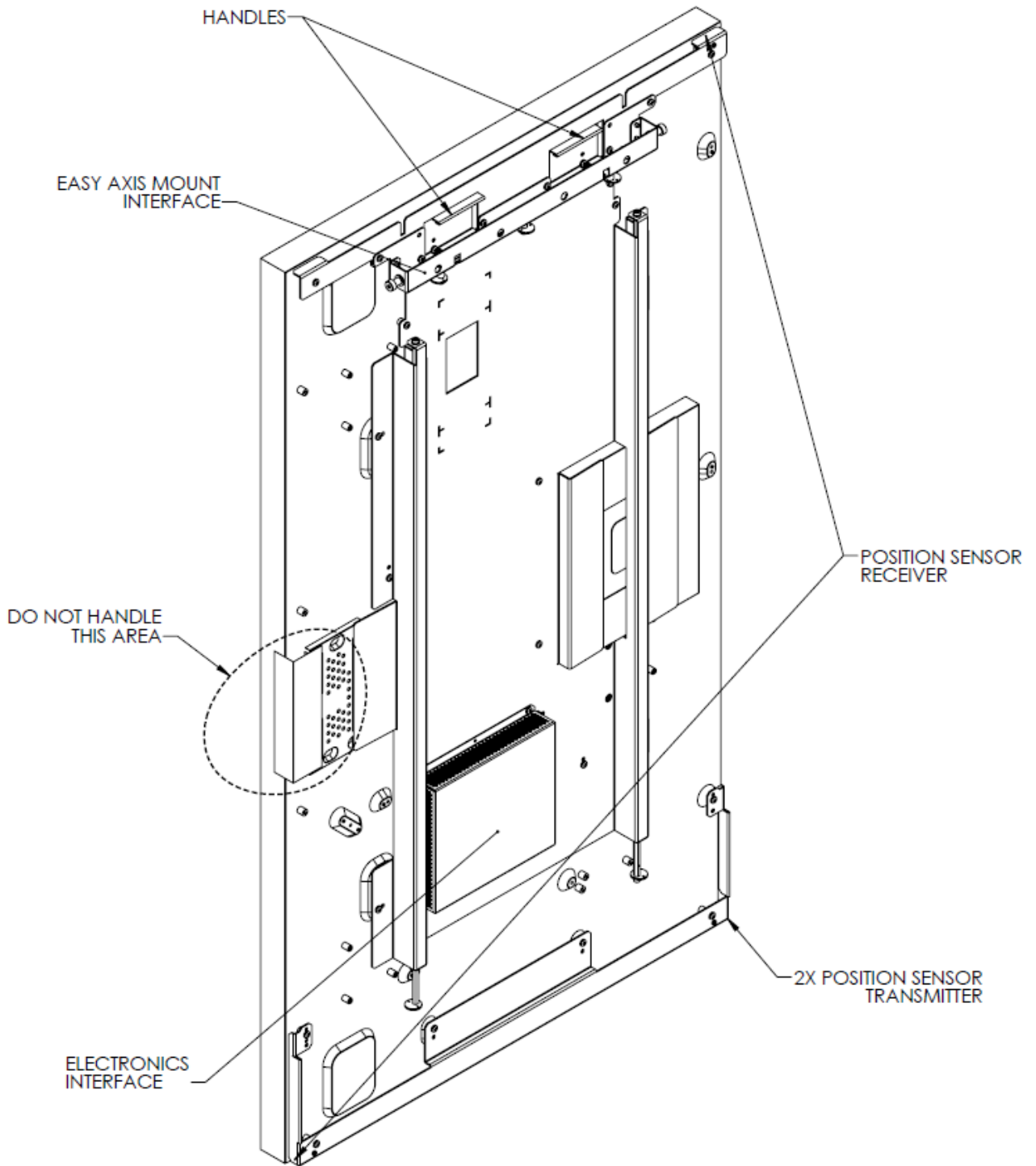

Drawings of Display Mounts

Click below to go to the drawings you want.

- [LX/MX55HDU and LX55HDS – Landscape](#)
- [LX/MX55HDU and LX55HDS – Portrait](#)
- [MX46HDU, MX46HDS, and LX46HDS – Landscape](#)
- [MX46HDU, MX46HDS, and LX46HDS – Portrait](#)
- [MX55HDS – Landscape](#)
- [MX55HDS – Portrait](#)
- [LX46S-3D – Landscape \(only\)](#)

LX/MX55HDU and LX55HDS – Portrait

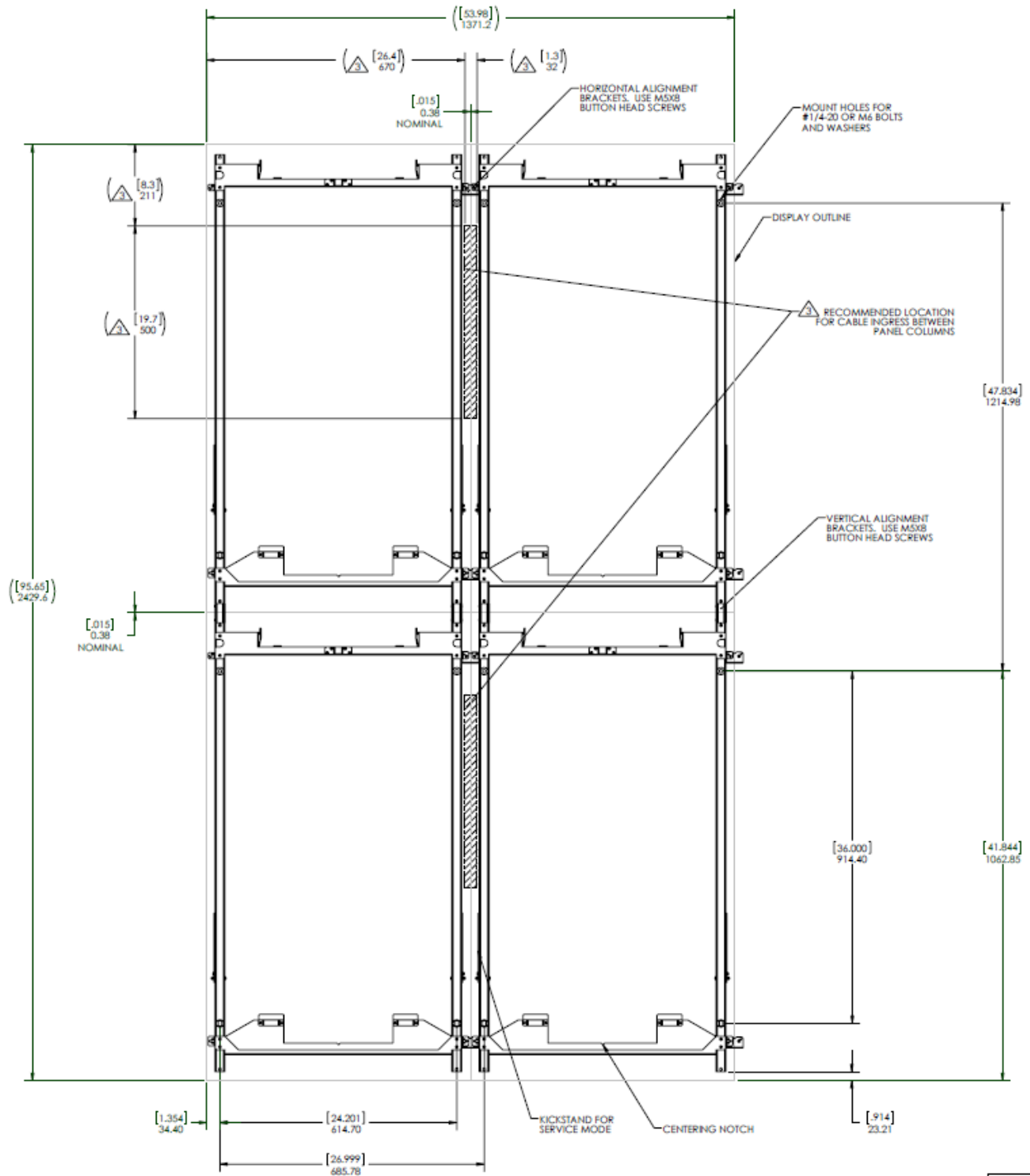

MX46HDU, MX46HDS, and LX46HDS – Portrait

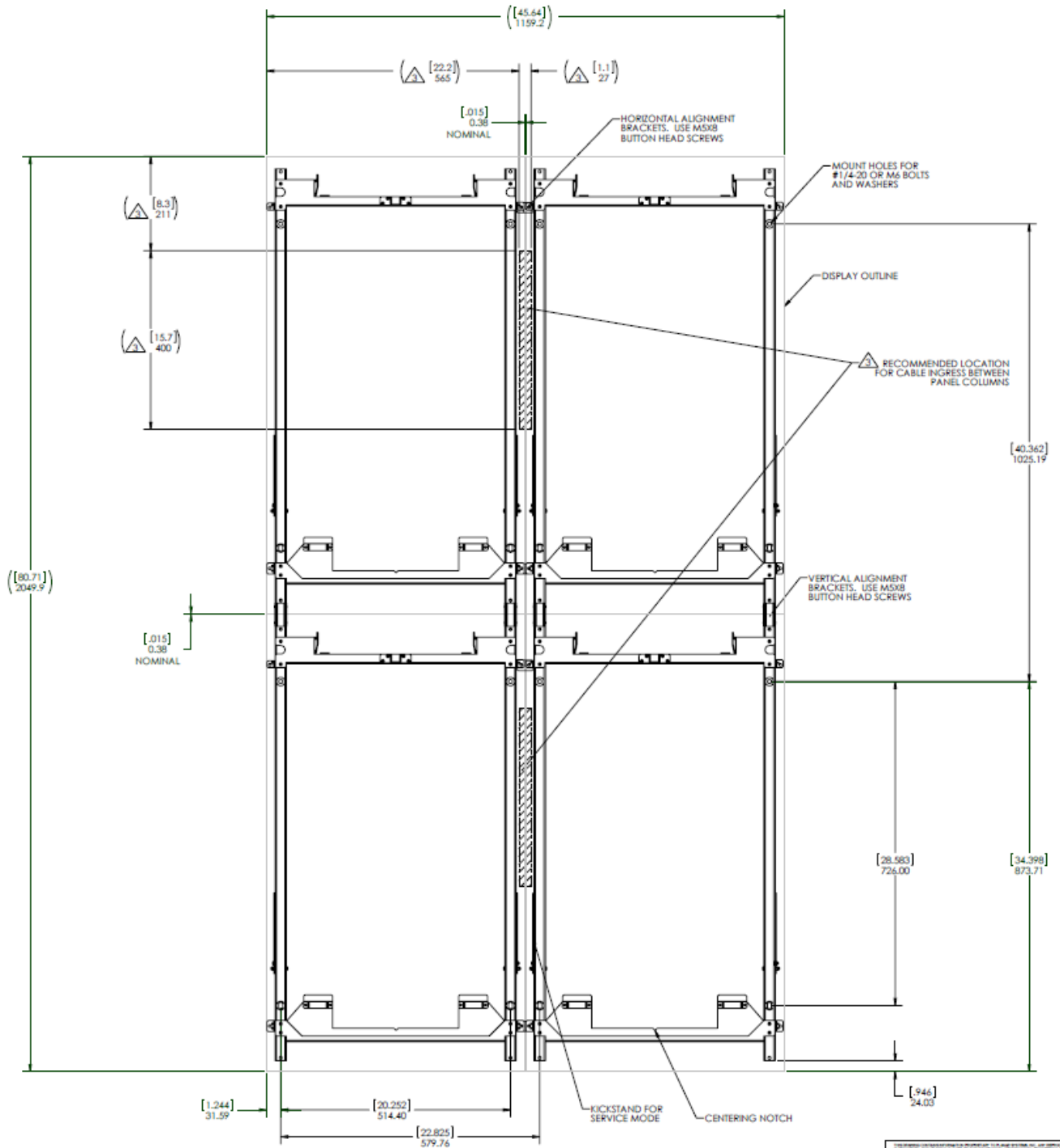

MX55HDS – Landscape

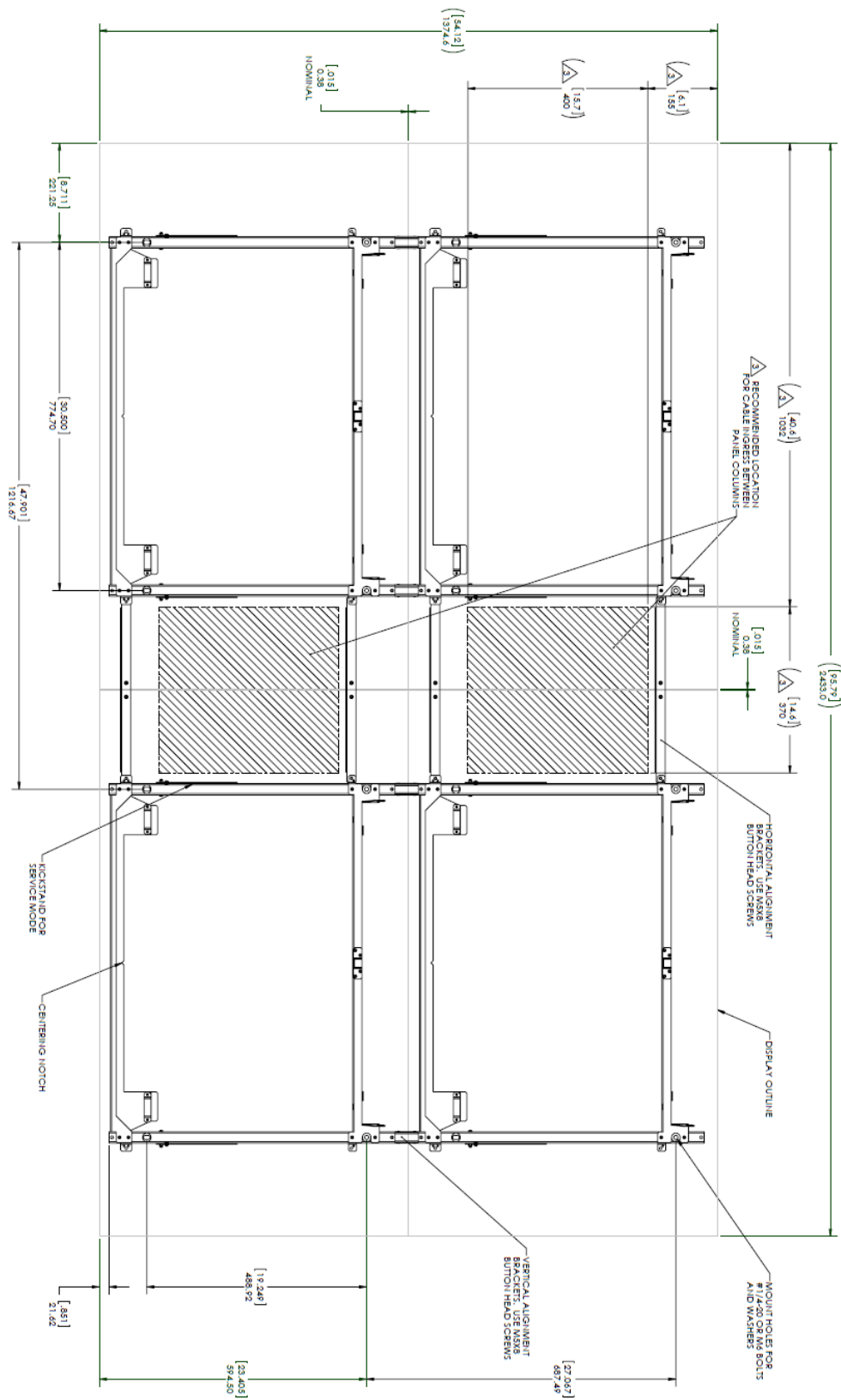

MX55HDS – Portrait

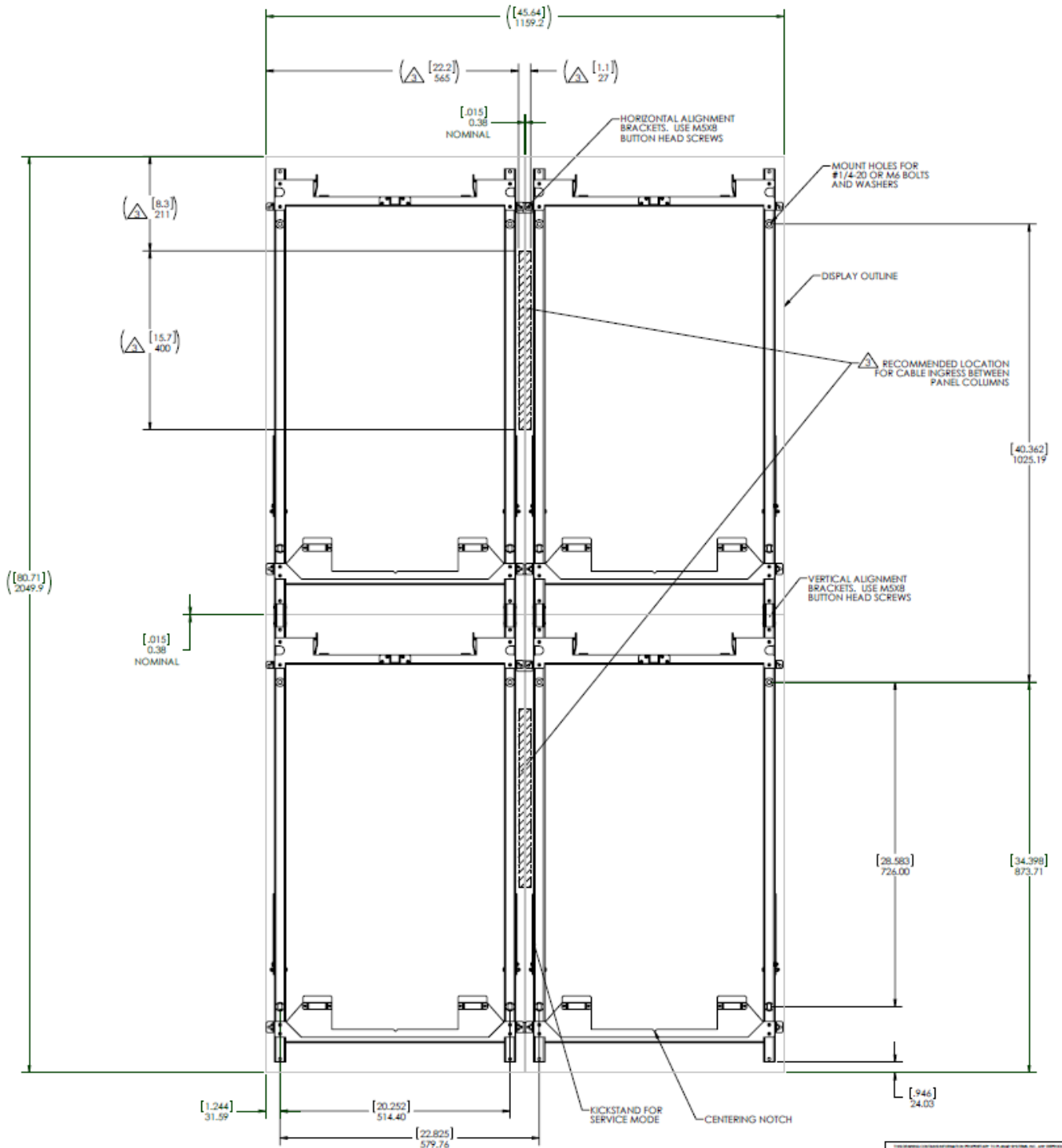

Dimensions of Electronic Components

Power Supply Module

POWER SUPPLY MODULE

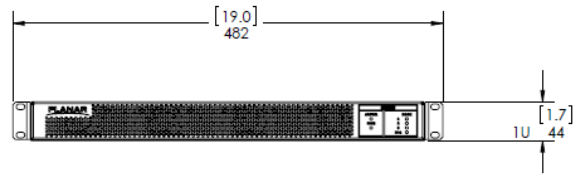
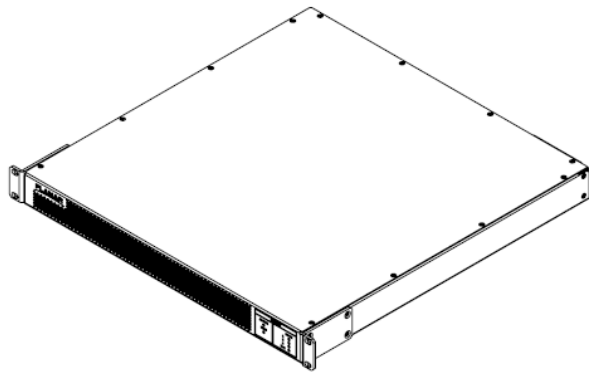

4X M4X0.8 FOR
FEET OR MOUNT
BRACKET
SCREW PENETRAION
4mm MAX

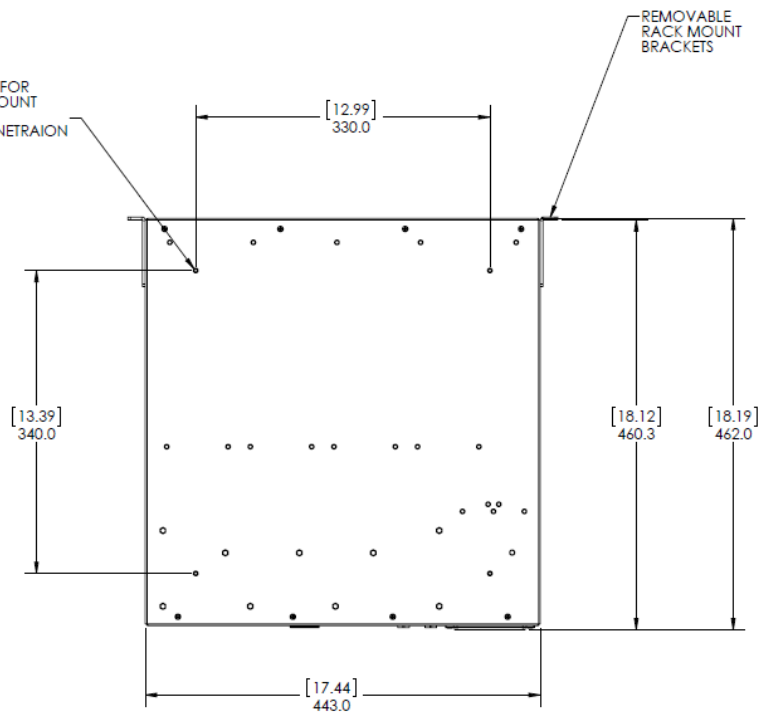

Quad Controller Module

QUAD CONTROLLER MODULE

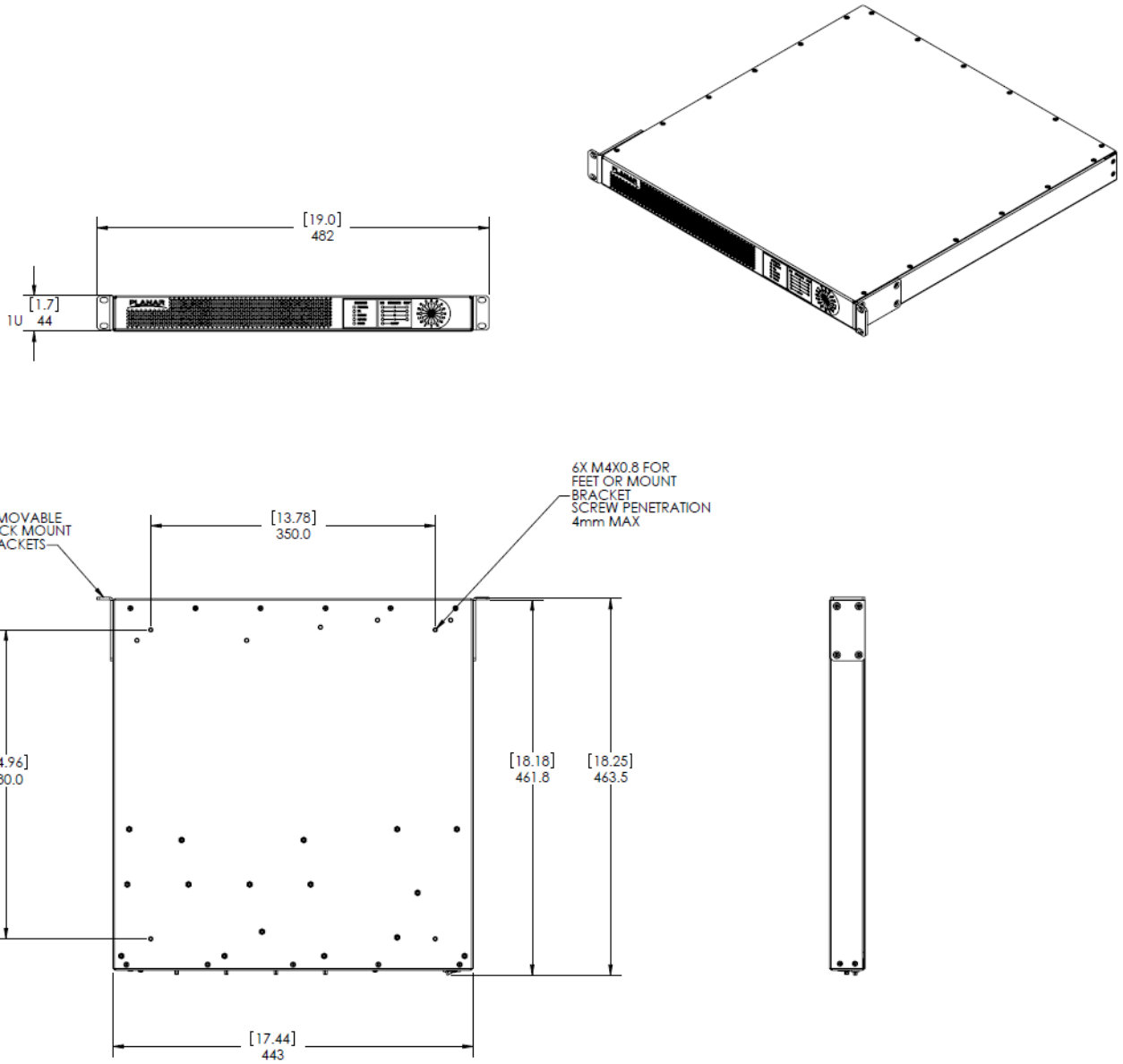

Main DC Power Cable

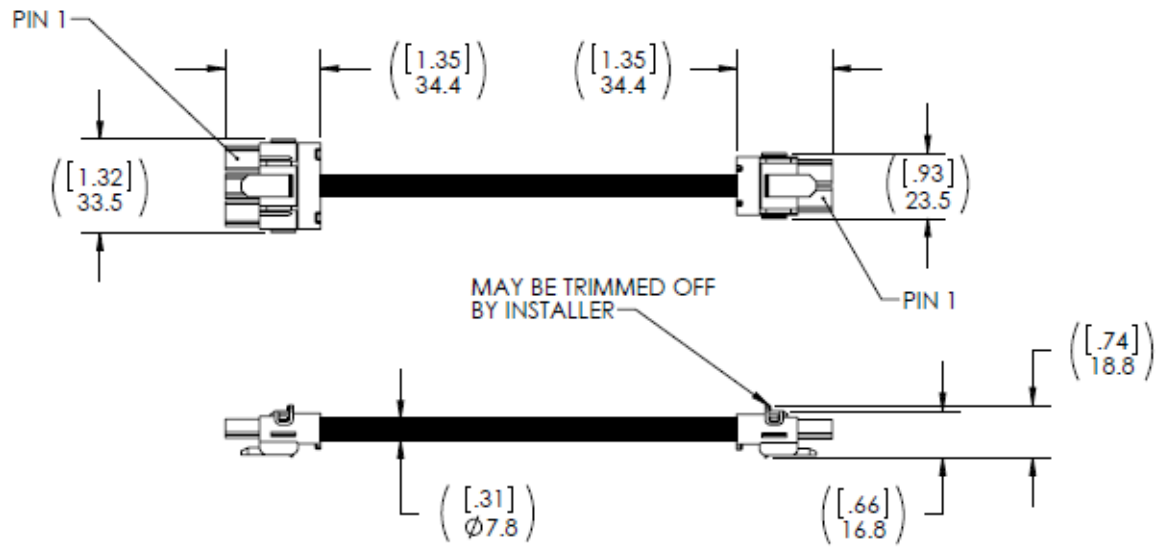

Power Supply to Quad Power Cable

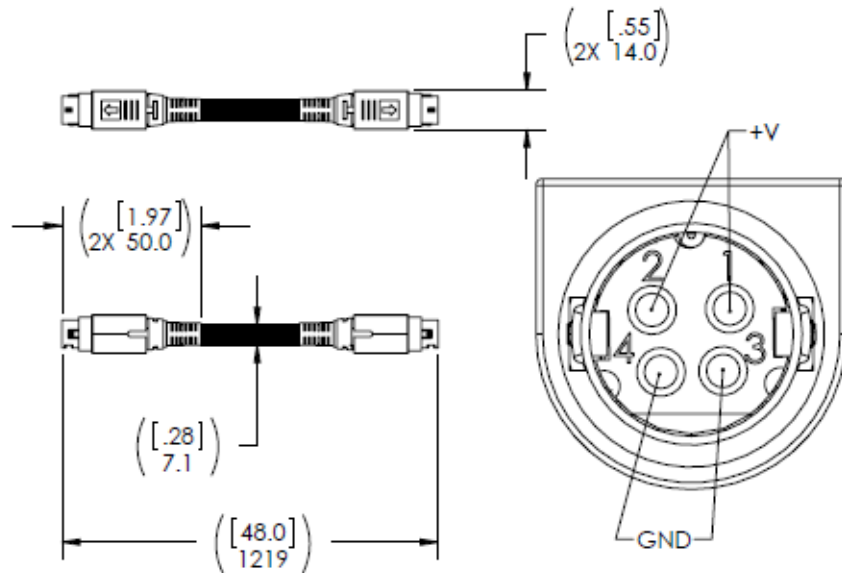

Installing Optional Accessories

These instructions show you how to install the optional stud adapter bracket for your Matrix G2 Video Wall.

Note: These instructions apply *only* to **Clarity Matrix with G2 Architecture** walls.

For each LCD module, the stud adapter bracket kit contains the following items:

- 2 Adapter brackets



- Four M6 nuts/washers

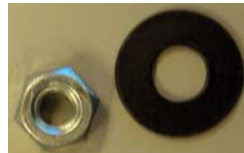

- 1 Install the LCD mount on the adapter brackets.

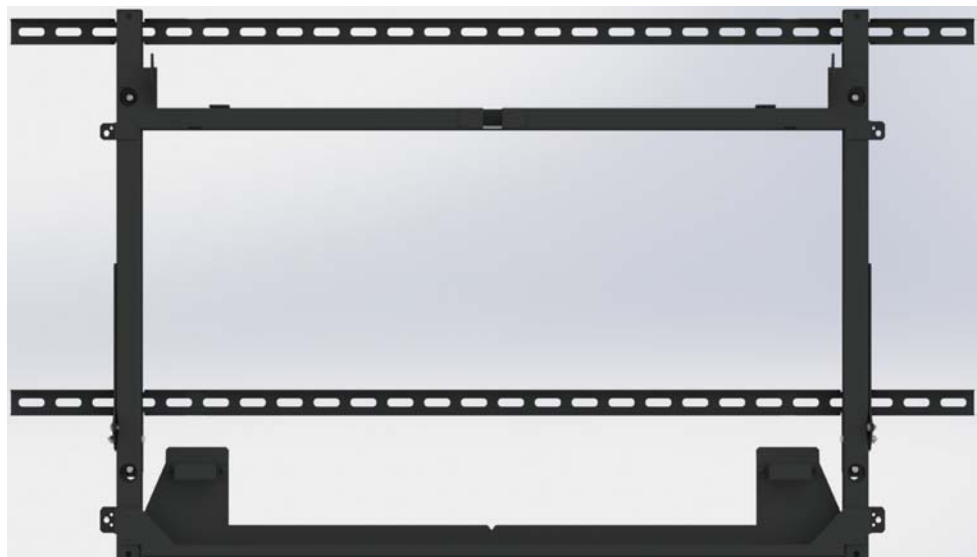

- 2 Install an M6 washer/nut in each mount point of the LCD mount.

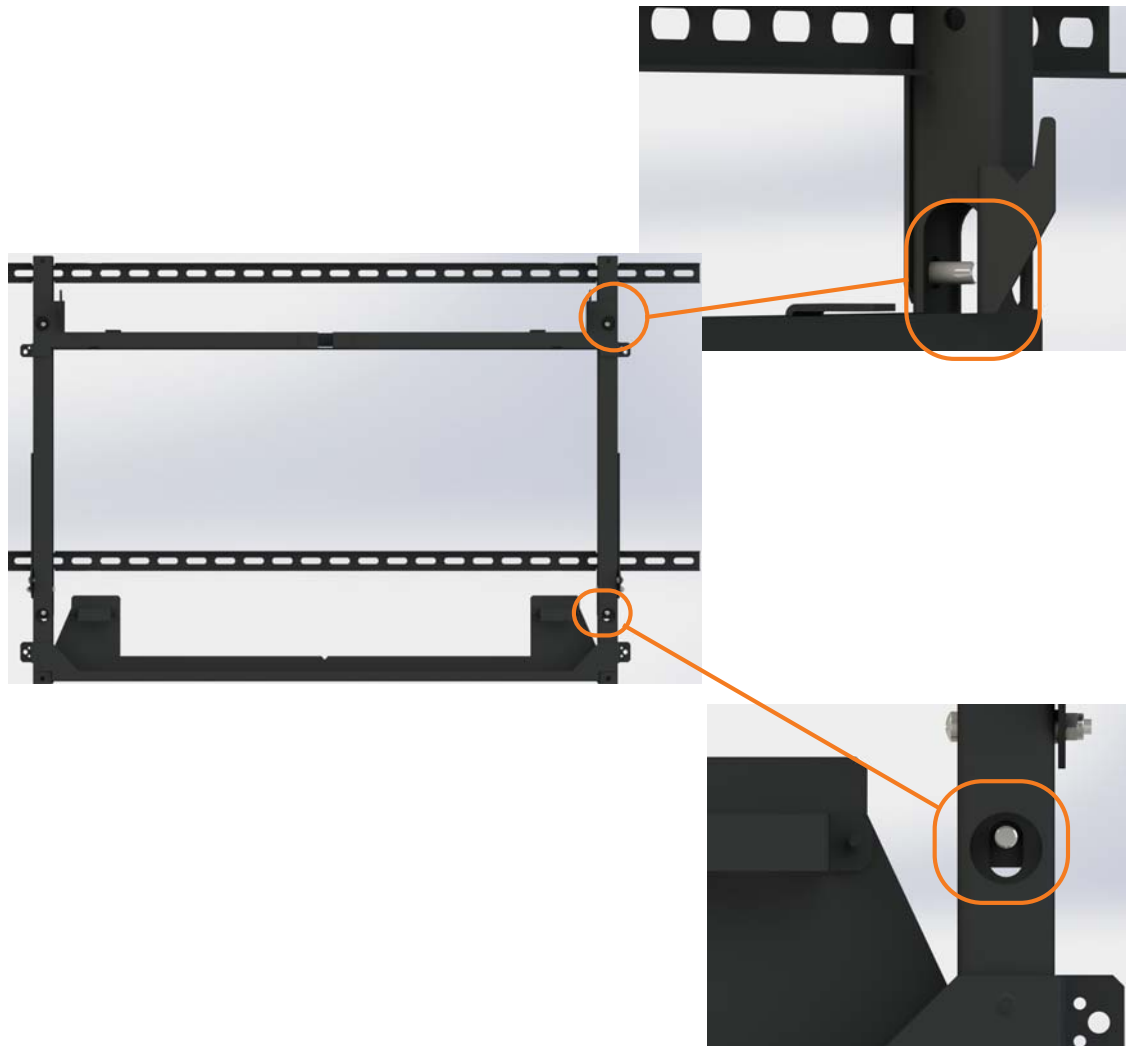

- 3 Repeat steps 1-2 for each LCD module that you want to mount to a wall.

Planar's Technical Support Website

- 1 <http://www.planar.com/support/>
- 2 Once you enter your login and password, you can access downloadable utility software, new firmware, user manuals, and service manuals.

Downloading Additional Documentation and Firmware

Some of the other documents for the Planar Matrix, which are or will be available from the Technical Support Department website, are listed below.

| Document Name | Contents |
|----------------------|--|
| Installation Guide | Information for installers and technicians to install and configure displays. |
| USB Reference Manual | Technical information about the product, such as display mode information and how to use USB commands to control displays. |

Downloading Utility Software

- 1 <http://www.planar.com/support/>
 - 1 Enter your login and password information.
 - 2 Navigate to the section that contains software updates and then look for Planar Matrix.
 - 3 From the list of available software, click on the tool you need.

Regulatory Information

Manufacturer's Name: Planar Systems, Inc.
Manufacturer's Address: 1195 NW Compton Drive
Beaverton, OR 97006

Declares that the product: Clarity™ Matrix LCD Video Wall System with G2 Architecture
Conforms with the provisions of:

Council Directive 2004/108/EC on Electromagnetic Compatibility;

EN55022:2010/AC:2011 Radiated and Conducted Emissions from IT Equipment

EN55024:1998 Immunity of IT Equipment

Including: EN61000-4-2 Electrostatic Discharge
EN61000-4-3 Radiated Immunity
EN61000-4-4 Electrical Fast Transients
EN61000-4-5 Line Surge
EN61000-4-6 RF Conducted Susceptibility
EN61000-4-8 Magnetic Field Immunity
EN61000-4-11 Voltage Dips and Interrupts

And: EN61000-3-2 Harmonic Current Emissions
EN61000-3-3 Voltage fluctuations and Flicker

Council Directive 2006/95/EC on Low Voltage Equipment Safety:

EN60950-1:2006+A12:2011 Safety of IT Equipment

The Technical Construction File required by this Directive is maintained at the corporate headquarters of Planar Systems, Inc., 1195 NW Compton Drive, Beaverton, OR 97006.

Note: This equipment has been tested and found to comply with the limits for a Class A digital device, pursuant to part 15 of the FCC Rules. These limits are designed to provide reasonable protection against harmful interference when the equipment is operated in a commercial environment. This equipment generates, uses, and can radiate radio frequency energy and, if not installed and used in accordance with the instruction manual, may cause harmful interference to radio communications. Operation of this equipment in a residential area is likely to cause harmful interference in which case the user will be required to correct the interference at his own expense.

Industry Canada (ICES-003): This Class A digital apparatus complies with Canadian ICES-003.

Cet appareil numérique de la classe A est conforme à la norme NMB-003 du Canada.

Any changes or modifications to the display not expressly approved by Planar could void the user's authority to operate this equipment.

Other Certifications

CISPR 22

Index

Operation Numbers

- 1 to 1 pixels, 88
- 10 bits per color, allowing, 79

A

- accessories
 - accessory box contents, 31
 - accessory kit contents, 32
 - checking, 27
 - customer-supplied, 34
 - electronics box contents, 29
 - LCD module box contents, 30
 - optional, 34
- adapter
 - bracket for wall studs, 38
- address adjustment tool, 34
- addresses, system, 60
- adjusting
 - color balance, 71
 - color temperature, 71
 - walls during installation, 46
- adjusting walls, tips for, 46
- adjustment
 - x-axis, 55
 - y-axis, 54
 - z-axis, 54
- alignment tool, 34
- allow 10 bits per color, 79
- allow frame lock, 79
- ambient light sensor, 92
- ambient light sensor, mounting, 58
- ambient operating temperature, 172
- ambient threshold, 91
- arrows in menus, 65
- aspect ratio, 166
 - definition of, 86
 - landscape, 167, 168
 - menu, 86
 - portrait, 166, 167, 168
- auto backlight on, 91
- automatic discovery of LCDs, 70
- automatic shutoff, scheduling, 83

- average use per day, 108
- avoiding temporary image retention, 5

B

- backlight
 - auto on, 91
 - control menu, 72, 90
 - high temperature warning, 91
 - hours, 167, 168
 - intensity, 91
 - time, 108
 - turn off with no source, 91
 - usage hours, 108
- backlight, hours, 166
- barometric pressure, 172
- baseline display, 74
- basic
 - configuration, 64
 - connections example, 14
- before you begin
 - installing a wall, 21
 - tools/equipment list, 21
- bezel compensation, 99
- big picture, 97
 - configuration, 122
 - matrix position, 97
 - setup menu, 97
- big picture key, 96
- black level, 72
- blanking specifications, 177
- bracket, stud adapter, 235
- brackets
 - horizontal, 31, 37
 - installing of subsequent rows, 41
 - installing on first row, 39
 - mounting to a wall, 37
 - vertical, 31, 38
 - wall stud adapter, 38
- brightness
 - screen, 170
 - where stored, 111

C

- cables
 - AC power, 31
 - connecting, 50
 - connecting RS232, 69
 - for dual link, 142
 - labels for identifying, 34
 - power, 29
 - power supply monitor, 29
 - routing, 42
- certifications, 238
- checking unit status, 107
- Clarity Matrix Video Wall, system architecture, 12
- cleaning ERO matrix wall, 178
- cleaning the LCD screen, 21
- clock, setting ahead/behind one hour, 84
- color balance
 - adjusting, 71
 - menu, 73
 - multiple displays, 72
 - tips, 75
 - where stored, 111
- color gamut, 170
- color native CIE, 170
- color temperature
 - adjusting, 71
 - understanding, 71
- column, base installation, 35
- complex configurations scenarios, 136
- component
 - heat load, 23
 - power requirements, 23
- configuration
 - basic steps, 64
 - new high resolution inputs, 142
 - of a video wall, 64
 - of high resolution inputs, 140
 - scenarios, 120
 - clarity big picture, 122
 - individual inputs, 121
 - multiple large sub walls, 136
 - multiple sub walls, 131
 - one sub wall and individual inputs, 124
 - one sub wall per Quad Controller
 - module, 128
 - standard cabling, 120
 - two sub wall per Quad Controller

- module, 129
 - understanding, 119
- conformity information, 238
- connecting IR remote sensor, 57
- connections, 59
- connectors, input, switching, 113
- contrast ratio, 170
- contrast, where stored, 111
- cooling requirements, 23
- customer-supplied accessories, 34

D

- deleting a memory, 117
- diagnostic information, 107
- dimensions
 - LCD module, 166, 167, 168, 195
 - LCD mount, 166, 167, 168
 - Quad Controller module, 169
- display IDs, 68

drawings, 180

- LX46HDS display (L), 195
- LX46HDS display (P), 198
- LX46HDS mount (L), 227
- LX46HDS mount (P), 228
- LX46S-3D display (L), 207
- LX46S-3D mount (L), 231
- LX55HDS display (L), 201
- LX55HDS display (P), 204
- LX55HDS mount (L), 225
- LX55HDS mount (P), 226
- LX55HDU display (L), 217
- LX55HDU display (P), 220
- LX55HDU mount (L), 225
- LX55HDU mount (P), 226
- MX46HDS display (L), 181
- MX46HDS display (P), 184
- MX46HDS mount (L), 227
- MX46HDS mount (P), 228
- MX46HDU display (L), 210
- MX46HDU display (P), 213
- MX46HDU mount (L), 227
- MX46HDU mount (P), 228
- MX55HDS display (L), 188
- MX55HDS display (P), 191
- MX55HDS mount (L), 229
- MX55HDS mount (P), 230
- MX55HDU display (L), 217
- MX55HDU display (P), 220
- MX55HDU mount (L), 225
- MX55HDU mount (P), 226
- power supply module, 232
- Quad Controller module, 233

dual link

- cabling, 142
- vs. single link, 141

E

EasyAxis, 30

- description of mounts, 14
- installing the mount, 36
- mount, 37
 - weight, 167
- mounting structure, 15, 16

equipment

- list, 21
- rack, 12

external video processor, 96

F

- factory color balance, reset to, 71
- fill both ways, 87
- fine-tune adjustment, 55, 57
- first row installation, 39
- frame
 - compensation, 99
 - height and width, 100
 - lock, 79
- free-standing mount, 35

G

global

- menus, 66
- saving, 112
- storage, 111

gloves for screen handling, 32

gray test pattern, 74

H

- heat load, 23
- hide source absent message, 78
- high resolution inputs, 142
 - cabling for dual link, 142
 - configuring, 140
 - dual link vs. single link, 141
 - hardware limitations, 140
 - setting up, 140
 - support resolutions, 143
 - vertical resolutions more than 2047 pixels, 143
- high temperature warning, 91
- horizontal, bracket, 31, 37
- hours menu, 108
 - where stored, 111
- how NOT to handle the LCDs, 8
- how to remove the liner, ERO units, 11
- how to remove the liner, non, 10
- how to safely handle LCDs, 9
- hue, where stored, 111
- humidity, 172

I

image position, 89

indicator lights on Quad Controller module, 62
 individual inputs scenario, 121
 input

- connectors, switching, 113
- high resolution, 140

 Input Levels menu, 80
 installation

- adjusting during installation, 46
- brackets
 - first row, 39
 - on subsequent rows, 41
- checklist, 27
- LCD modules
 - first row, 48
 - subsequent rows, 56
- mount points, 39
- mounting brackets to wall, 37
- of EasyAxis mount, 36
- of LCD modules, 8
- of video wall, 21, 35
- optional accessories, 235
- planning, 22
- routing cables, 42
- space requirements, 23

 IR remote sensor, connecting, 57
 IR sensor, 33
 IR sensor, mounting, 57
 IR sensor, mounting the, 57

J

justify settings, 89

K

keep original size, 88

L

labels for identifying cables, 34

LCD

- average use per day, 108
- optical specifications, 170
- temperature, 107
- too large or too small, 46
- wipes for cleaning, 21

- LCD module, 12, 15, 30
 - color CIE, 170
 - color gamut, 170
 - contents in box, 30
 - contrast ratio, 170
 - dimensions, 166, 167, 168, 195
 - gloves for handling, 32
 - how NOT to handle the LCDs, 8
 - how to safely handle LCDs, 9
 - installing first row, 48
 - installing subsequent rows, 56
 - mounting structure, 16
 - operating temperature, 172
 - orientation, 167, 168
 - screen brightness, 170
 - service mode, 50
 - servicing, 165
 - specifications, 166, 167, 168
 - uniformity, 170
 - viewing angle, 170

LCD mount, 15, 30, 37

- dimensions, 166, 167, 168
- identifying center, 39
- installing, 36
 - LCD too large or small, 46
 - weight, 167, 168

LEDs on Quad Controller module, 62

liner, removing, ERO units, 11

Liner, removing, non-ERO units, 10

local menus, 67

LX46HDS display (L), drawings of, 195

LX46HDS display (P), drawings of, 198

LX46HDS mount (L), drawing of, 227

LX46HDS mount (P), drawing of, 228

LX46S-3D display (L), drawings of, 207

LX46S-3D mount (L), drawing of, 231

LX55HDS display (L), drawings of, 201

LX55HDS display (P), drawings of, 204

LX55HDS mount (L), drawing of, 225

LX55HDS mount (P), drawing of, 226

LX55HDU display (L), drawings of, 217

LX55HDU display (P), drawings of, 220

LX55HDU mount (L), drawing of, 225

LX55HDU mount (P), drawing of, 226

M

manufacturer's address, 238

master display, 64

- Matrix layout menu, 70
- matrix position, 97
- Matrix video wall
 - depth, 36
 - LCD modules, 15
- mechanical specifications, 169
- memory
 - deleting one, 117
 - slots, 114
- menu
 - arrows in, 65
 - aspect ratio, 86
 - backlight control, 90
 - big picture setup, 97
 - color balance, 73
 - delete (memory), 117
 - hours, 108
 - input levels, 80
 - matrix layout, 70
 - miscellaneous options, 78
 - on-screen menu tree, 145
 - orientation, 78
 - picture, 80
 - picture position, 104
 - recall, 115
 - rotation, 78
 - save, 113
 - scale mode, 86
 - serial port settings, 105
 - size & position, 102
 - unit status, 107
 - viewport, 102
 - zoom, 101
- menu tree
 - aspect ratio, 148
 - big picture, 146
 - delete memory, 149
 - diagnostics, 150
 - input levels, 148
 - main menu, 145
 - matrix layout, 147
 - memory, 149
 - picture, 148
 - picture information, 148
 - picture setup, 148
 - program information, 145
 - quad module route, 147
 - quick configure, 146
 - recall memory, 149
 - serial port status, 150
 - unit status, 150
 - wall configuration, 146
- menu types
 - global, 66
 - local, 67
 - navigational, 66
 - status, 66
- menus, 65
- minimum sync specifications, 177
- miscellaneous options menu, where stored, 111
- mount
 - brackets to a wall, 37
 - IR sensor, 57
 - points on a wall, 39
- mounting ambient light sensor, 58
- mullion compensation, 99
- multiple sub walls scenario, 131
- MX46HDS display (L), drawings of, 181
- MX46HDS display (P), drawings of, 184
- MX46HDS mount (L), drawing of, 227
- MX46HDS mount (P), drawing of, 228
- MX46HDU display (L), drawings of, 210
- MX46HDU display (P), drawings of, 213
- MX46HDU mount (L), drawing of, 227
- MX46HDU mount (P), drawing of, 228
- MX55HDS display (L), drawings of, 188
- MX55HDS display (P), drawings of, 191
- MX55HDS mount (L), drawing of, 229
- MX55HDS mount (P), drawing of, 230
- MX55HDU display (L), drawings of, 217
- MX55HDU display (P), drawings of, 220
- MX55HDU mount (L), drawing of, 225
- MX55HDU mount (P), drawing of, 226

N

- native
 - color, 170
 - resolution, 172
 - native color balance, reset to, 71
 - navigational menus, 66
 - normal use thermal guidelines, 6
-

O

- off-board equipment, 18
 - off-board equipment, placing, 44
 - one sub wall and individual inputs, 124
 - on-screen menus, 65
 - operating temperature, 172
 - LCD module, 172
 - power supply module, 172
 - Quad Controller module, 172
 - operating time of LCD, 109
 - optical specifications, 170
 - optional accessories, 34
 - installing, 235
 - optional stud adapter bracket, 235
 - orientation of LCD module, 167, 168
 - orientation of menus, 78
 - overwriting a memory, 114
-

P

- parameters, saved, 112
 - Picture menu, 80
 - picture position, 104
 - placing off-board equipment, 44
 - planning your installation, 22
 - position, where stored, 111
 - power cable, 29
 - power requirements, 23
 - power supply module, 12, 19, 29
 - drawing of, 232
 - LED indicators, 19
 - operating temperature, 172
 - placing, 44
 - specifications, 169
 - power supply monitor cable, 29
 - power supply, identifying module type, 20
 - pressure, barometric, 172
-

Q

- Quad Controller module, 12, 18, 29
 - address adjustment tool, 34
 - digital video inputs, 138
 - dimensions, 169
 - drawing of, 233
 - operating temperature, 172
 - placing, 44
 - route menu, 139
 - route menu, understanding, 138
 - RS485 connections, 58
 - specifications, 169
 - status LEDs, 62
 - temperature, 107
 - understanding, 139
 - weight, 169
-

R

- rear clearance requirements, 166, 167, 168
 - recall, 113
 - recommended usage, 5
 - regulatory information, 238
 - remote control, 65
 - reset to factory, 71
 - reset to native, 71
 - resetting color balance, 71
 - resolution
 - of LCD module, 172
 - supported high resolutions, 143
 - vertical more than 2047 pixels, 143
 - rotate menu, 78
 - rotation menu, 78
 - routing
 - cables, 42
 - sources, 120
 - RS232
 - communication, 69
 - connecting cables, 69
 - connector, 169
 - RS485
 - connector, 169
 - Quad Controller connections, 58
-

S

- safety, 2
-

saturation, where stored, 111
 save, 113
 saved parameters, 112
 saving your work, 113
 scale mode settings, 86, 87
 scheduling events, 83
 screen brightness, 170
 sensor, ambient light, mounting, 58
 sensor, IR remote, connecting, 57
 serial port

- diagnostic values, 106
- settings, 105

 service mode of LCD module, 50
 service plans, ii
 servicing LCD modules, 165
 setting clock ahead/behind one hour, 84
 sharpness, 89
 sharpness, where stored, 111
 signal compatibility, 173
 single link vs. dual link, 141
 size, where stored, 111
 slave displays, 64
 slot memory, 114
 source absent message, hiding the, 78
 source routing, 120
 space requirements for installation, 23
 specifications

- environmental, 172
- input minimum sync and blanking, 177
- LCD module, 166, 167, 168
- LCD optical, 170
- mechanical, 169
- power supply module, 169
- Quad Controller module, 169
- signal compatibility, 173

 standard

- cabling scenarios, 120
- cabling with restrictions scenarios, 128, 129, 131
- wall installation, 35

 Status LEDs on Quad Controller, 62
 status menus, 66
 stud adapter bracket, 235
 switching input connectors, 113
 system

- architecture, 12
- time, 108
- usage
 - hours per day, 108
 - number of days over 20 hours, 109

 System Addresses, 60

T

temperature

- of LCD, 107
- of Quad Controller module, 108
- operating, 172
- requirements for normal use, 6
- warning, 91

 temporary image retention, 5, 90
 test pattern

- gray, 74
- white, 73

 thermal guidelines, 6
 tiling the video wall, 96
 tips for wall installation, 46
 TIR, temporary image retention, 90
 tools/equipment list, 21
 troubleshooting, 157
 turning the display(s) on/off, 83

U

understanding

- color temperature, 71
- quad module route menu, 138
- wall configuration, 119

 uniformity of LCD module, 170
 unit

- column and row, 98
- status menu, 107

 unpacking accessories, 27
 usage information, 5

V

ventilation requirements, 23
 vertical bracket, 31, 38
 video

- controls, 72
- inputs digital, 138

 viewing angle of LCD, 170
 viewport, 102

W

wall

- configuration, 119, 120
- installation, 35
 - adjusting during, 46
 - before you build, 35
 - column base, 35
 - free-standing mount, 35
 - options, 35
 - standard, 35
- mode, 98
- width and height, 97

warranty information, ii

weight, 167

LCD module, 167, 168

LCD mount, 167, 168

Quad Controller module, 169

white level, 72

white test pattern, 73

X

x-axis adjustment, 55

Y

y-axis adjustment, 54

Z

z-axis adjustment, 54

zoom menus, 101