

MDSC-8231

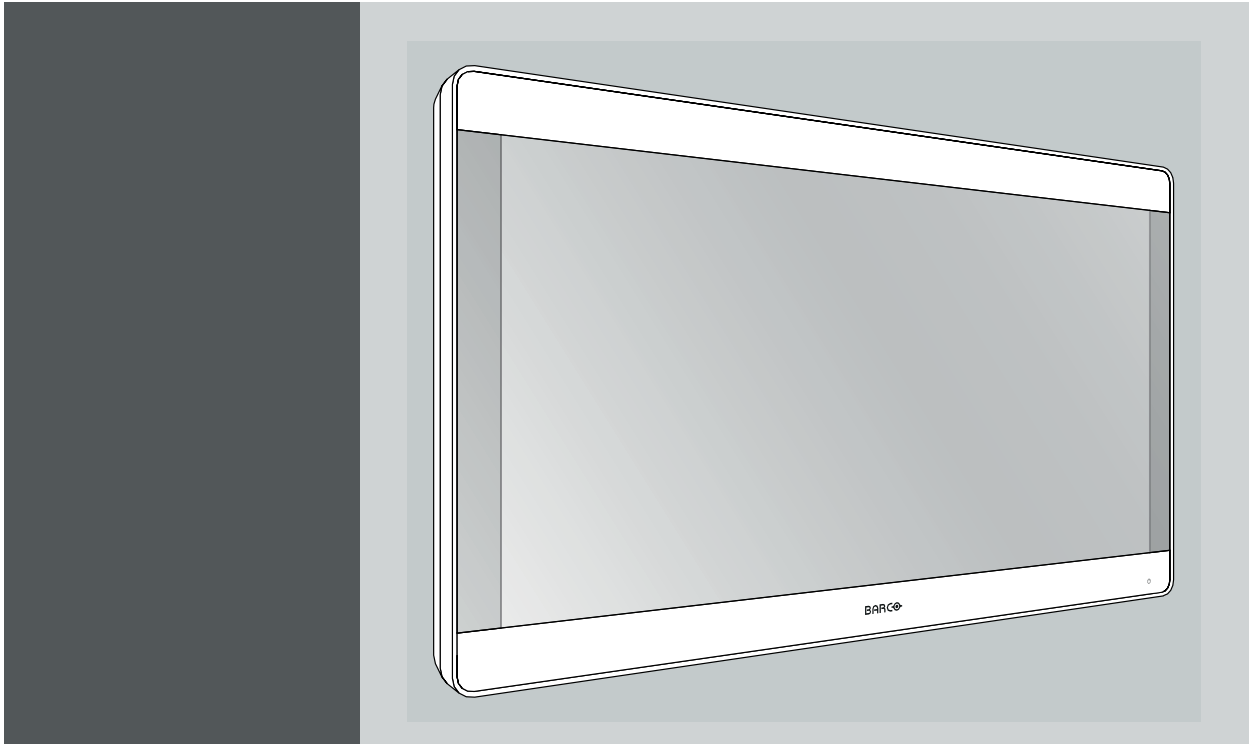

User Guide 31-inch UHD 4K surgical color display

MDSC-8231 LED
MDSC-8231 MNA

Barco NV
President Kennedypark 35, 8500 Kortrijk, Belgium
Phone: +32 56.23.32.11
Fax: +32 56.26.22.62
Support: www.barco.com/en/support
Visit us at the web: www.barco.com

Printed in Belgium

TABLE OF CONTENTS

1. Welcome!	3
1.1 About the product	3
1.2 What's in the box	3
1.3 About this user guide	4
2. Parts, controls and connectors	5
2.1 Front view	5
2.2 Rear view	6
2.3 Connector view	6
2.3.1 MDSC-8231 LED version	6
2.3.2 MDSC-8231 MNA version	7
2.4 Connector pin assignments	7
2.4.1 Input power connector	7
2.4.2 DVI connector (DVI-D)	8
2.4.3 USB connector	8
2.4.4 Micro-USB connector	9
2.4.5 DisplayPort connector	9
3. Display installation	11
3.1 Cover removal	11
3.2 Interface connection	11
3.2.1 MDSC-8231 LED version	12
3.2.2 MDSC-8231 MNA version	12
3.3 Power supply connection	13
3.4 Cable routing	15
3.5 VESA mount installation	15
4. Daily operation	17
4.1 On/Off switching	17
4.2 Keyboard locking/unlocking	17
4.3 Power mode LED	18
4.4 OSD menu activation	18
4.5 OSD menu navigation	19
4.6 Shortkey functions	20
4.6.1 Main source selection	20
4.6.2 Brightness adjustment	21
4.7 OSD menu locking/unlocking	21
5. Advanced operation	23
5.1 Picture menu	23
5.1.1 Profile	23
5.1.2 Brightness	23
5.1.3 Contrast	24
5.1.4 Saturation	24
5.1.5 Color temperature	24
5.1.6 Color space	25
5.1.7 Gamma	25
5.1.8 Sharpness	25
5.2 Picture advanced menu	26
5.2.1 Black Level	26
5.2.2 Latency	26
5.2.3 Image Size	26
5.2.4 Image Flip	27
5.2.5 Screen Resolution	27
5.3 Input select menu	28
5.3.1 Main Source	28
5.3.2 DisplayPort mode	28
5.3.3 Auto search	29

Table of contents

5.3.4	Failover input	29
5.3.5	2 nd Picture Mode	30
5.3.6	2 nd Picture Source.....	30
5.4	Configuration menu.....	30
5.4.1	Information	30
5.4.2	Language.....	31
5.4.3	Source shortkey (Main source selection).....	31
5.4.4	OSD setting	32
5.4.4.1	OSD Horizontal Position	32
5.4.4.2	OSD Vertical Position	32
5.4.4.3	OSD Time-out.....	32
5.4.5	Recall Profile.....	32
5.4.6	Save Profile	33
5.5	System menu.....	33
5.5.1	Power on DVI	33
5.5.2	Power on DisplayPort.....	34
5.5.3	OSD lock	34
5.5.4	Power saving	34
5.5.5	DVI output.....	35
6.	Important information	37
6.1	Safety information.....	37
6.2	Environmental information	40
6.3	Biological hazard and returns.....	42
6.4	Regulatory compliance information	42
6.5	Cleaning and disinfection	43
6.6	Explanation of symbols.....	43
6.7	Legal disclaimer.....	45
6.8	Technical specifications	46

1. WELCOME!

1.1 About the product

Overview

Barco's MDSC-8231 is a 31-inch Ultra High Definition (UHD) surgical display. Purpose-built for the operating room, the MDSC-8231 offers an easy-clean design, smart mechanics and the most detailed images in the operating room today.

Ease of mind

Perfect hand-eye coordination: The display's high brightness, high contrast and UHD 4K resolution provide surgeons with excellent depth perception and the most accurate images. The MDSC-8231 presents images with unrivaled color and grayscale accuracy and with near-zero latency, making it perfectly suited for use with today's state-of-the-art endoscopy camera systems.

Multi-source, multi-display imaging: With its broad input connectivity, the MDSC-8231 also offers flexible multi-modality imaging in new integrated operating rooms. Thanks to its high-bright LED backlight with light output stabilization (BLOS), the surgical display also ensures a long lifetime and low power consumption.

Ease of installation

The MDSC-8231 comes with a smart cable management system that hides the cables for a clutter-free set-up. Equipped with VESA 100 and VESA 200 interface to allow easy mounting on surgical booms and spring arms. Available in different models, this surgical display also features a host of connectivity options and remote control.

Ease of use

Barco's MDSC-8231 allows easy cleaning thanks to its smooth surface and protective screen cover.

Features

- 31-inch wide-screen LCD with UHD 4K resolution and 10-bit per color
- Wide viewing angle
- Wide color gamut
- High-brightness LED backlight
- Backlight Output Stabilization over time
- Advanced, full 10-bit image processing algorithms with 14-bit LUT
- UHD 4K input on DisplayPort or Fiber Optic Nexxis (MDSC-8231 MNA only), FHD input on DVI and 3G-SDI
- Easily mountable onto a boom

Innovative features, such as Failover Mode, are also available to give maximum flexibility when installing the display and ensures a backup signal is always available for safe surgery.

1.2 What's in the box

Overview

Your MDSC-8231 display comes with:

1. Welcome!

- MDSC-8231 user guide (booklet)
- DisplayPort cable
- AC power cords
- external power supply



The user guide is available in other languages on www.barco.com/support



Keep your original packaging. It is designed for this display and is the ideal protection during transport.

1.3 About this user guide

Overview

This manual provides support to the user during the installation, set up and utilization of the MDSC-8231 display. Depending on the specific version that has been purchased, some of the features and options described in this document may not apply to the display in user's hands.

2. PARTS, CONTROLS AND CONNECTORS

2.1 Front view

Overview

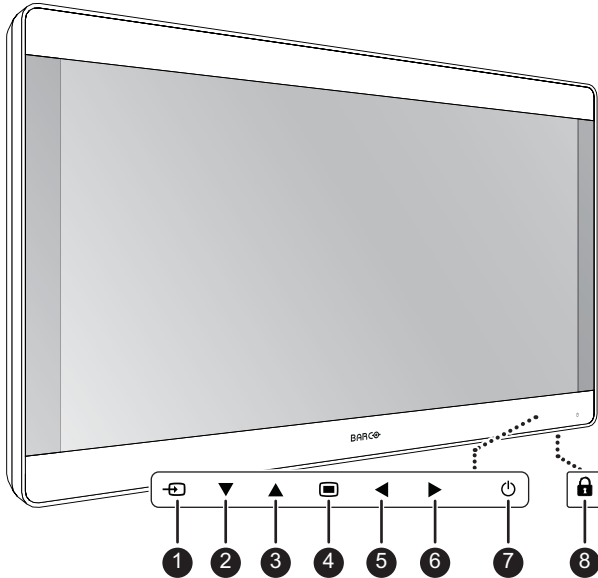

Image 2-1

A 7-key capacitive keypad is located on the front of the display. By default only the stand-by key (7) is visible. For keyboard activation please refer to "Keyboard locking/unlocking", page 17.

1. Source shortkey
2. Down key
3. Up key
4. OSD menu / Enter key
5. Left / Brightness decrease key
6. Right / Brightness increase key
7. Stand-by key / Power mode LED
8. Keyboard lock/unlock button (membrane switch at the bottom of the display)



The keyboard lock/unlock button may be activated accidentally when placing the display on a flat surface with the bottom facing downwards. Persistent key pressures will automatically be ignored by the keyboard control SW however.

2.2 Rear view

Overview

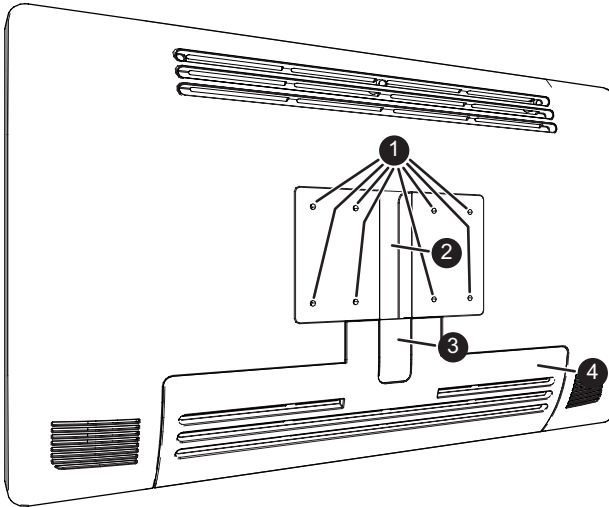

Image 2-2

1. VESA mount screw holes (100 x 100 mm, 200 x 100 mm)
2. Cable routing channel
3. Cable routing channel expansion clip
4. Connector compartment cover

2.3 Connector view

2.3.1 MDSC-8231 LED version

Overview

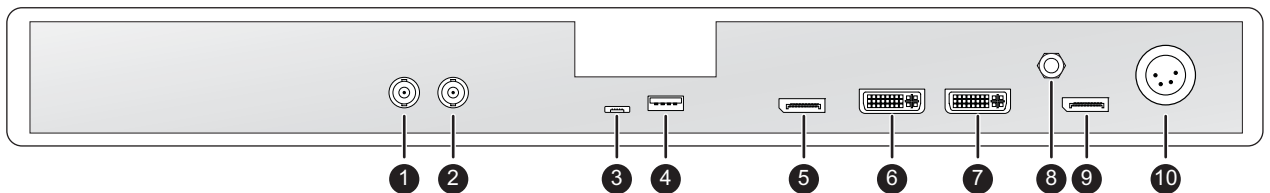

Image 2-3

1. SDI in
2. SDI out
3. USB 2.0 micro-B interface
4. USB 2.0 type A interface
5. Main (Right) DisplayPort in
6. DVI-D in
7. DVI-D out
8. Potential Equalization pin (POAG)
9. 2nd (Left) DisplayPort in
10. 24 VDC power in

2.3.2 MDSC-8231 MNA version

Overview

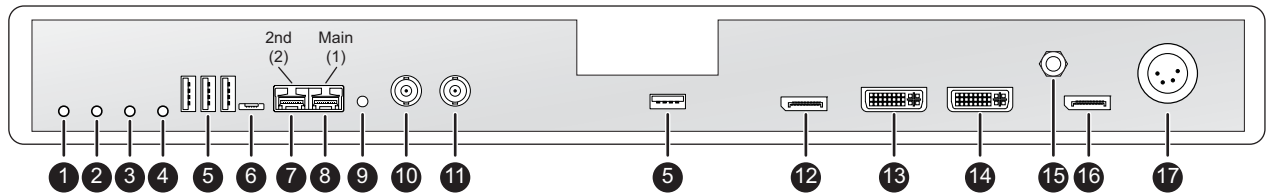

Image 2-4

1. Headphone out
2. Microphone in
3. Audio line out
4. Audio line in
5. USB 2.0 type A interface (4 x)
6. USB 2.0 micro-B interface (for service use only)
7. (2) Secondary SFP+ 10Gb optical Ethernet interface
8. (1) Main SFP+ 10Gb optical Ethernet interface
9. Identification button
10. SDI in
11. SDI out
12. Main (Right) DisplayPort in
13. DVI-D in
14. DVI-D out
15. Potential Equalization pin (POAG)
16. 2nd (Left) DisplayPort in
17. 24 VDC power in



Input and Output 1 to 9 are directly connected to the embedded Nexxis decoder.

2.4 Connector pin assignments

2.4.1 Input power connector

Overview



Image 2-5

1. +24 VDC
2. +24 VDC
3. GND
4. GND

2. Parts, controls and connectors



CAUTION: The ground and the shield connections on the power input connector have no Protective Earth function. A Protective Earth connection is provided via a dedicated pin (see "Power supply connection", page 13).

2.4.2 DVI connector (DVI-D)

Overview

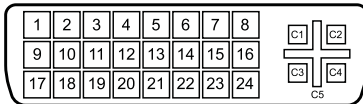

Image 2-6

1. D2_Rx- (T.M.D.S.)
2. D2_Rx+ (T.M.D.S.)
3. GND (data 2 shield)
4. Not connected
5. Not connected
6. SCL (for DDC)
7. SDA (for DDC)
8. Not connected
9. D1_Rx- (T.M.D.S.)
10. D1_Rx+ (T.M.D.S.)
11. GND (data 1 shield)
12. Not connected
13. Not connected
14. +5V output (*)
15. GND (cable sense)
16. Hot plug detect (*)
17. D0_Rx- (T.M.D.S.)
18. D0_Rx+ (T.M.D.S.)
19. GND (data 0 shield)
20. Not connected
21. Not connected
22. GND (clock shield)
23. CK_Rx+ (T.M.D.S.)
24. CK_Rx- (T.M.D.S.)

(*) +5 VDC output selectable on either pin 14 or 16 via the OSD menu. (+5V \pm 10% @ 500mA (max))

2.4.3 USB connector

Overview

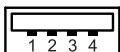

Image 2-7

1. +5 VDC
2. Data -
3. Data +
4. GND

2.4.4 Micro-USB connector

Overview

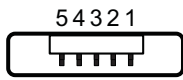

Image 2-8

1. +5 VDC
2. Data -
3. Data +
4. GND
5. Not connected

2.4.5 DisplayPort connector

Overview

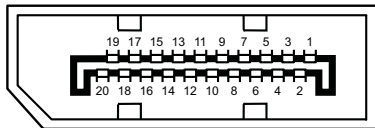

Image 2-9

1. ML_Lane 0 (p)
2. GND
3. ML_Lane 0 (n)
4. ML_Lane 1 (p)
5. GND
6. ML_Lane 1 (n)
7. ML_Lane 2 (p)
8. GND
9. ML_Lane 2 (n)
10. ML_Lane 3 (p)
11. GND
12. ML_Lane 3 (n)
13. CONFIG1
14. CONFIG2
15. AUX CH (p)
16. GND
17. AUX CH (n)
18. Hot Plug
19. Return
20. DP_PWR (+3.3 VDC @ 500 mA max)

3. DISPLAY INSTALLATION

3.1 Cover removal

To remove the connector compartment cover

Slide the connector compartment cover downwards to get access to the connectors.

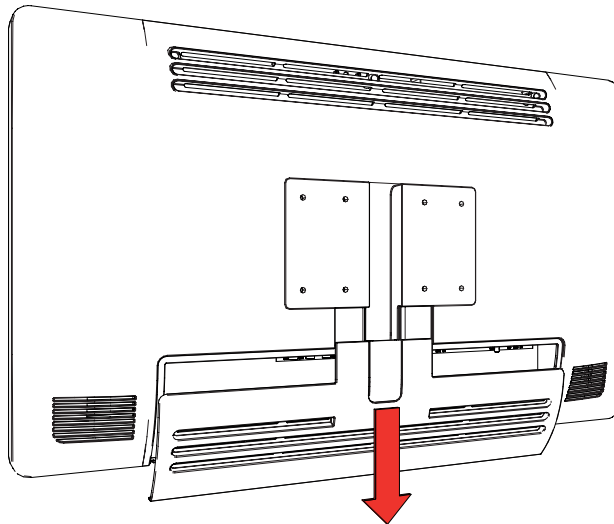

Image 3-1

3.2 Interface connection

About

The MDSC-8231 can have multiple video inputs connected. Switching between the different inputs can be done easily with the Source shortkey (⊖).

Futhermore, if more than one video source is connected, the Picture in Picture (PiP) functionality becomes available, allowing you to view two different video inputs at once. Please refer to "2nd Picture Mode", page 30 and "2nd Picture Source", page 30 for more information.

Beside the video input connections, the MDSC-8231 also has video output capabilities allowing you to loop-through or duplicate all video inputs connected with the MDSC-8231 to another display, projector, video recorder, ...

This chapter describes how to connect the different video interface types to the MDSC-8231.

Nexxis OR

Connecting your MDSC-8231 to Barco's Nexxis OR system allows you to distribute video, graphics, audio and computer data over the IP network, in raw uncompressed format, inside the operating room and even between surgical suites.

To connect your MDSC-8231 to Barco's Nexxis OR system, connect the 10Gb Ethernet interface to your Nexxis switch. More info about Nexxis OR and how to configure the MDSC-8231 in your network is available in the dedicated user guides. Please visit www.barco.com to obtain these user guides.



Nexxis OR is only available on the MDSC-8231 MNA version.

3.2.1 MDSC-8231 LED version

To connect the interfaces

1. Connect one or more video source(s) to the corresponding video inputs of the display.
UHD 4K video can be connected in two ways:
 - 1 x DisplayPort 1.2 MST connected to the Main DisplayPort input or,
 - 2 x DisplayPort 1.1 connected to the Main and 2nd DisplayPort input, where each input drives one half (right/left) of the screen.

Warning: DisplayPort VESA DP 1.2 certified cables for 5.4 Gbps HBR2 are recommended.

2. When the SDI video input is connected, an additional SDI video sink can be connected to the SDI output (= SDI input loop-through).
3. Screen image clone: The entire active image on the screen (including OSD) can be duplicated to a FHD (1080p/1080i) signal on the DVI output connector, to which an additional DVI video sink can be connected. For 4K images, the central part of the image (pillarbox to 16:9) will be down-scaled to FHD resolution.

Note: The DVI output must be enabled in the OSD menu (please refer to "DVI output", page 35).

4. Connect the micro-USB interface with a workstation to use the remote control protocol, to update the display firmware, or to be able to connect any USB peripheral with the USB interfaces of the display.
5. Use any USB peripheral (keyboard, mouse, webcam, ...) by connecting it to the USB interface (a host PC connected to micro USB-port is required).

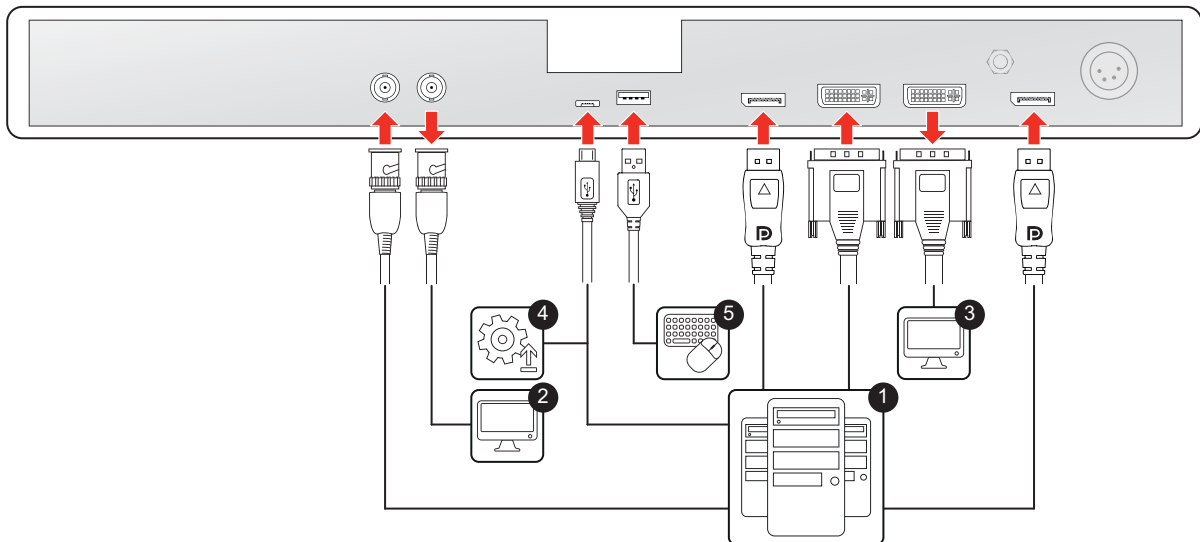

Image 3-2

3.2.2 MDSC-8231 MNA version

To connect the interfaces

1. Connect one or more video source(s) to the corresponding video inputs of the display.
UHD 4K video can be connected in three ways:

- 1 x DisplayPort 1.2 MST connected to the Main DisplayPort input or,
- 2 x DisplayPort 1.1 connected to the Main and 2nd DisplayPort input, where each input drives one half (right/left) of the screen or,
- Nexxis link: 2 x 10Gb Ethernet connected to the Main and Secondary SFP+ 10Gb optical Ethernet interface, where each input drives one half (right/left) of the screen.

Warning: DisplayPort VESA DP 1.2 certified cables for 5.4 Gbps HBR2 are recommended.

2. When the SDI video input is connected, an additional SDI video sink can be connected to the SDI output (= SDI input loop-through).
3. Screen image clone: The entire active image on the screen (including OSD) can be duplicated to a FHD (1080p/1080i) signal on the DVI output connector, to which an additional DVI video sink can be connected. For 4K images, the central part of the image (pillarbox to 16:9) will be down-scaled to FHD resolution.
Note: The DVI output must be enabled in the OSD menu (please refer to "DVI output", page 35).
4. Use any USB peripheral (keyboard, mouse, webcam, ...) by connecting it to the available USB interfaces.
5. Connect a headphone to the appropriate output to listen to audio sent over Nexxis.
6. Connect a microphone to the appropriate input to send spoken audio over Nexxis.
7. Connect a (set of) speaker(s) to the line out interface to listen to audio sent over Nexxis.
8. Connect any kind audio player to the line in interface to send audio over Nexxis.
9. Connect the display with Nexxis to use the remote control protocol or to update the display firmware.

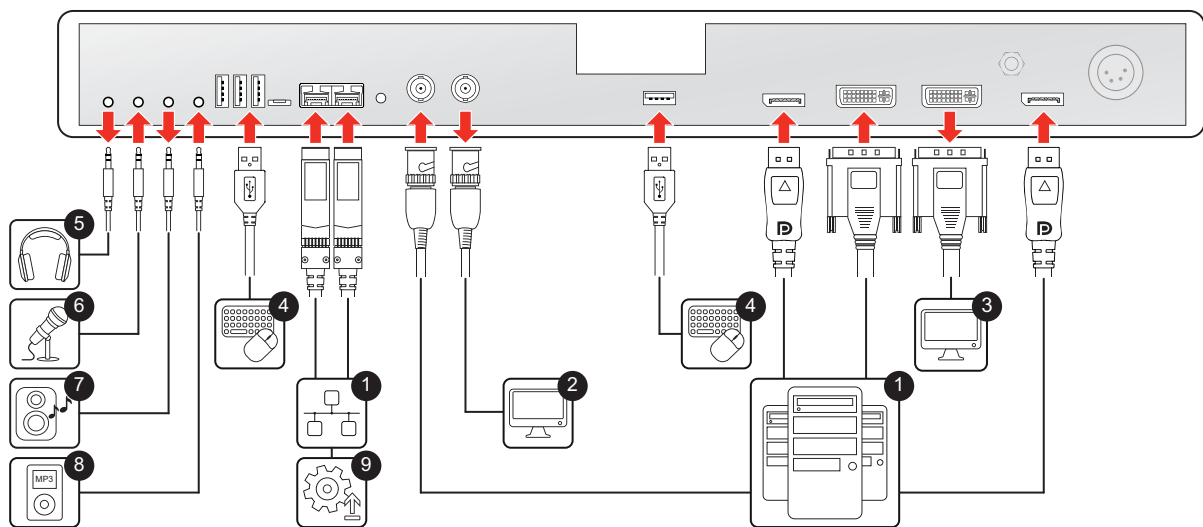

Image 3-3

3.3 Power supply connection

To connect the power supply

1. Connect the supplied external DC power supply unit to the +24 VDC power input of your display.
2. Plug the other end of the external DC power supply into a **grounded** power outlet by means of the proper power cord delivered in the packaging.

3. Display installation

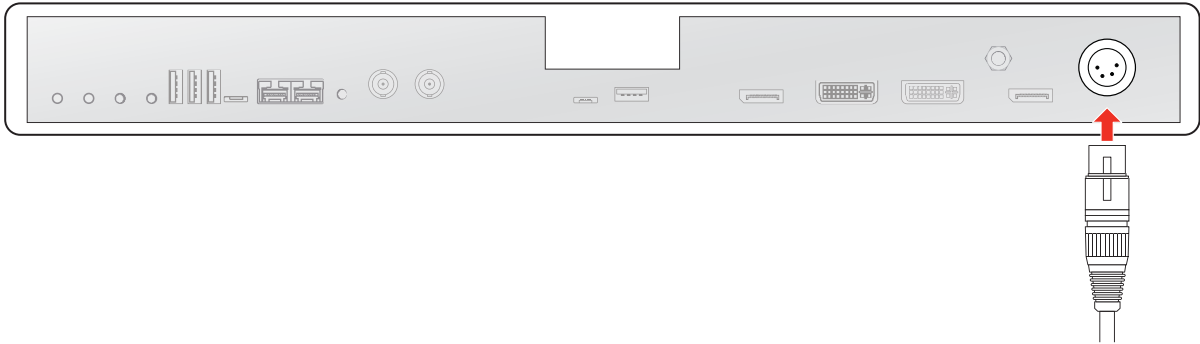

Image 3-4



CAUTION: To avoid risk of electric shock, the external DC power supply must be connected to a mains with protective earth. The ground connection on the display's DC power input connector has no protective earth function. The MDSC-8231 display protective earth connection is provided via a dedicate pin (see next steps).

Potential equalization

When potential equalization between the display and other devices is required then connect the potential equalization pin (POAG) to the potential equalization terminal of the equipment.

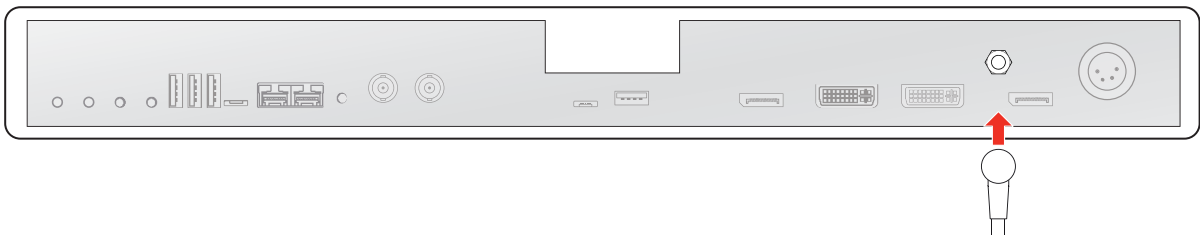

Image 3-5

Protective earth

Earth the MDSC-8231 by connecting the protective earth pin to a grounded outlet by means of a yellow/green AWG18 wire (maximum admitted cable length according to national regulation requirements).

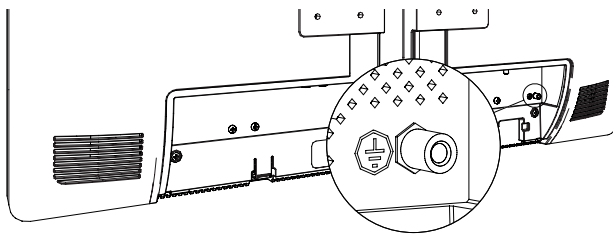

Image 3-6



CAUTION: The display must be earthed.

3.4 Cable routing

To route the cables

For displays to be mounted on a VESA arm **with** internal cable routing provisions, route all cables through the cable routing channel, then reinstall the connector compartment without removing the expansion clip.

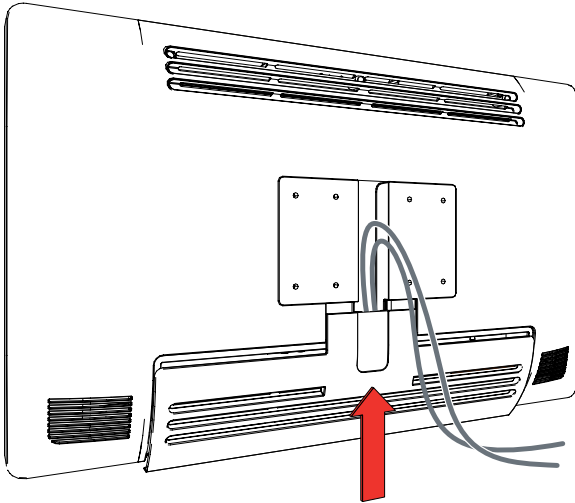

Image 3-7

For displays to be mounted on a VESA arm or stand **without** internal cable routing provisions, first remove the expansion clip from the connector compartment cover, then route all cables through it while reinstalling the cover.

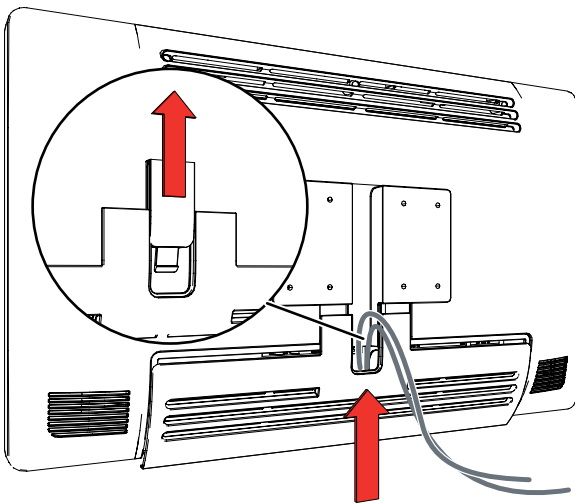

Image 3-8



CAUTION: When the display is assembled in the medical system, take care of the fixation of all cables, to avoid unwanted detachment.

3.5 VESA mount installation

To install the display on a VESA mounting solution

The display can be attached to a VESA 100 mm or VESA 200 mm arm or stand.

3. Display installation

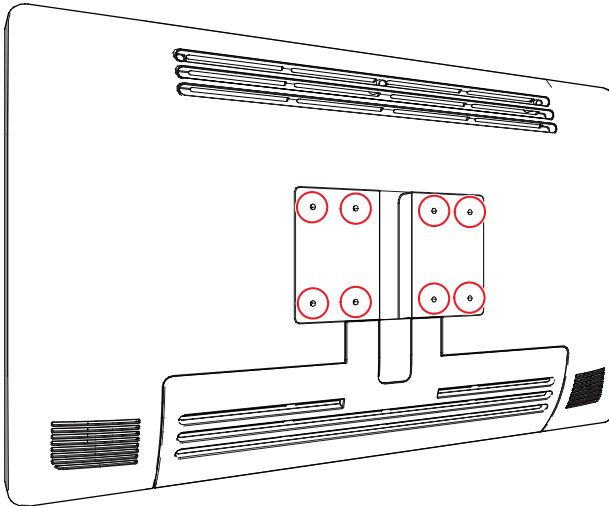

Image 3-9

The VESA mounting holes at the back of the display are provided with M4-type blind fasteners to fix the VESA mounting plate. Depending on the VESA plate thickness (T) and the thickness of possible washers (W), a different screw length (L) should be selected.

Please respect the following rule to select an appropriate screw length:

- $L_{\min} = T + W + 15 \text{ mm}$
- $L_{\max} = T + W + 18 \text{ mm}$

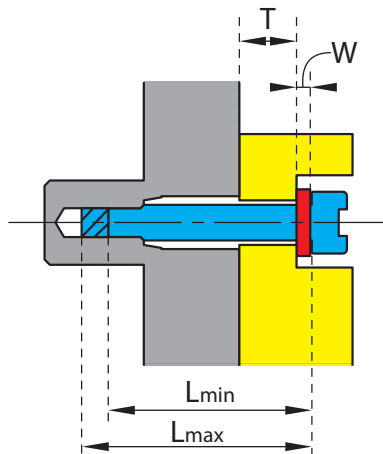

Image 3-10



CAUTION: Use an arm that is in compliance with VESA requirements.



CAUTION: The monitor VESA interface has been designed for a safety factor 6 (to support 6 times the monitor weight). In the medical system, use an arm with suitable safety factor (IEC60601-1).



4. DAILY OPERATION

4.1 On/Off switching



The procedures below consider that DC power is supplied to the display. Please check the status of the power mode LED to verify that your display is supplied with DC power (see "Power mode LED ", page 18).



To switch on your display

Press and hold (3-4 seconds) the  key until the entire keyboard lights up. Afterwards, release the  key again (within 2 seconds) to avoid a keyboard re-lock.



When the keyboard backlight lights up, the power mode LED will turn full green indicating that the display is switching on.

To switch off your display

1. Unlock the keyboard (see "Keyboard locking/unlocking", page 17).
2. With the keyboard unlocked, press and hold (3-4 seconds) the  key until the entire keyboard starts blinking quickly. Afterwards, release the  key again (within 2 seconds) to avoid a keyboard re-lock.

4.2 Keyboard locking/unlocking



About

In order to avoid unwanted or accidental activation of the keyboard, a lock/unlock mechanism has been implemented. This means that the keyboard needs to be unlocked before it can be used to change any of the display settings. By default, all keys except the  key will be dimmed to indicate that the keyboard is locked.

After unlocking the keyboard, all keys will light up. Touching any of these keys while the backlight is on will execute the function of the key. However, if no further action is taken within the time-out (10 seconds), the keys will dim again and the keyboard will re-lock.

To unlock the keyboard

Two options are available to unlock the keyboard:

1. Option 1: Press and hold (0.5 seconds) the keyboard unlock button () at the bottom of the display until the entire keyboard starts blinking slowly. Afterwards, release the  key again (within 2 seconds) to avoid a keyboard re-lock.

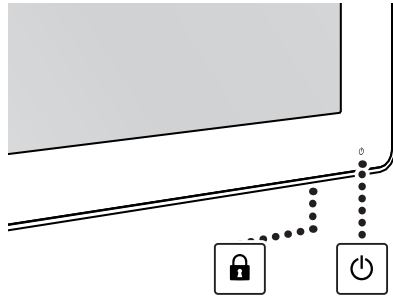



Image 4-1

2. Option 2: Press and hold (3-4 seconds) the  key until the entire keyboard starts blinking slowly. Afterwards, release the  key again (within 2 seconds) to avoid a keyboard re-lock.

To lock the keyboard

The keyboard will automatically lock after 10 seconds of inactivity, except while navigating the OSD menu, during which it remains unlocked.

4.3 Power mode LED

About the power mode LED

The behavior of the power LED shows the status of the unit:

OFF	Hard power OFF (power supply is unplugged)
Blinking orange	Soft power OFF (switched off by using the stand-by key ())
Full orange	Display is in power save mode (backlight and LCD off)
Blinking green / orange	Searching for signal Note: When Power save mode is enabled, the display will automatically go into power save mode after 10 seconds of searching without signal.
Full green	Display has a valid input signal.

4.4 OSD menu activation

To activate the OSD menu

1. Switch on the display (see "On/Off switching", page 17).
2. Unlock the keyboard (see "Keyboard locking/unlocking", page 17).
3. Press the  key.

As a result, the OSD main menu comes up in the bottom right corner of the screen. If no further actions are taken within the following 30 seconds, the OSD menu will disappear again.

If after pressing the  key, the *OSD lock* window appears then this means that the OSD lock has been enabled. Please refer to "OSD lock", page 34 for more information and instructions to unlock the OSD menu.



The time-out of the OSD menu automatic close function can be adjusted or disabled in the OSD menu (*OSD Time-out*).



The OSD menu position can be adjusted in the OSD menu (*OSD Hor. Pos.* and *OSD Vert. Pos.*).

4.5 OSD menu navigation

OSD menu structure explained

Below is an example of the OSD menu structure:

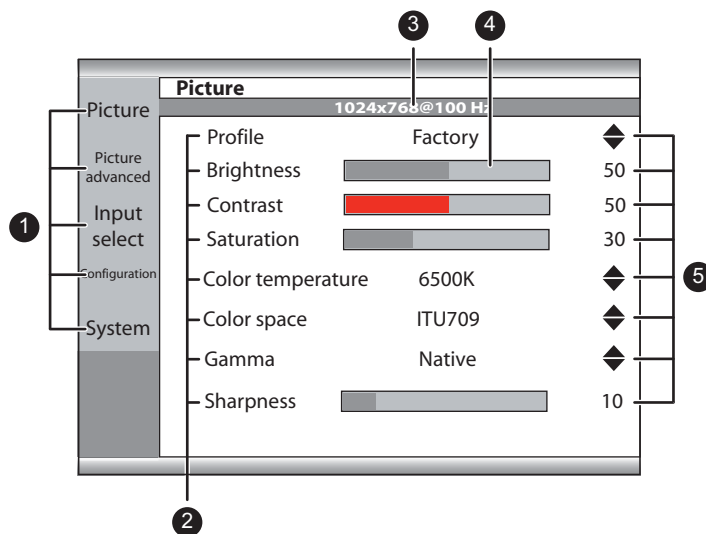

Image 4-2

1. Menu pages
2. Sub-menus (menu items)
3. Status bar
4. Selector/Slider
5. Item



















Grayed out menu items are not available on the specific display version.

To navigate through the OSD menu



Image 4-3

4. Daily operation

- Press the  key to open the OSD menu.
- Use the  or  key to scroll to the desired menu page.
- When the desired Menu page is highlighted, press the  key to select the top menu item that will be highlighted.
- Use the  or  keys to move to other Menu Items, then press the  key to select it.
- If the selected menu item is controlled by a slider use the  or  keys to adjust the item value, then press the  key to confirm.
- If the selected menu item is a multiple choices menu use the  or  keys to select the desired option then press the  key to confirm.
- Press again  or  key to select other Menu items or exit from the Menu page by pressing the  key.

4.6 Shortkey functions

About shortcut functions

The concept of shortcut functions is to present a selection of commonly used functions immediately available without the need to navigate through the OSD menu.

The different available shortcut functions are:

- Main source selection
- Brightness adjustment

Overview of shortcuts



Image 4-4

1. Main source selection
2. Brightness decrease
3. Brightness increase

4.6.1 Main source selection

To quickly select the main source

1. Unlock the keyboard (see "Keyboard locking/unlocking", page 17)
2. Press the  key to scroll through all the possible input signals and quickly select the main source.



Available main source options may differ depending on display model.



The main source shortcut function can be disabled in the OSD menus to avoid unwanted or accidental switching of the main input source (see "Source shortcut (Main source selection)", page 31).

4.6.2 Brightness adjustment

To quickly adjust the brightness

1. Unlock the keyboard (see "Keyboard locking/unlocking", page 17)
2. While no OSD menu is on the screen, press the ◀ or ▶ key to adjust the brightness as desired.

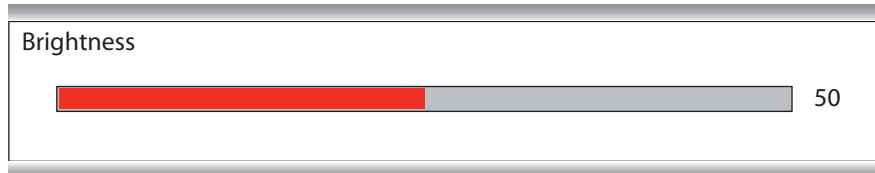

Image 4-5

4.7 OSD menu locking/unlocking

About the OSD lock

As described in "OSD lock", page 34, the OSD lock can be enabled to avoid unwanted access. When the OSD is locked, pressing the ◻ key after unlocking the keyboard will not activate the OSD menu, but will make the *OSD lock* window appear. The OSD menu can only be accessed after pressing a sequence of keys.

To lock/unlock the menu

1. Unlock the keyboard (see "Keyboard locking/unlocking", page 17)
2. Press the ◻ key.
3. When the *OSD lock* window appears, press the following key sequence to unlock the OSD menu:
◀, ▶, ▶, ▼

Each time a key is pressed an asterisk is shown in the square boxes.

After pressing the fourth key, if the sequence is correct, the OSD main menu is activated. After exit, the OSD menu will automatically lock again.

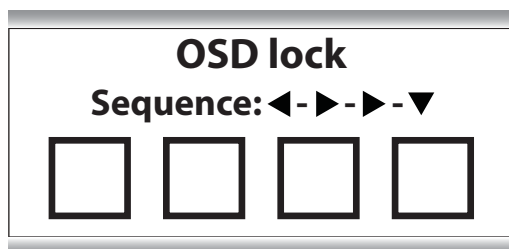

Image 4-6

4. Daily operation

5. ADVANCED OPERATION

5.1 Picture menu

5.1.1 Profile

About profiles

To select a profile means to load a set of predefined video parameters like Brightness, Contrast, Saturation, Input selection (Primary & Secondary), Multi-image layout selection, etc.

The user can modify the default video parameters associated to each profile and save the new parameters setting under the User 1, User 2 or User 3 profile. The Factory and X Ray profiles can be temporarily modified, but the factory default can't be overwritten and can always be recalled through the recall profile menu item.

The available profiles for your display are:

- Factory
- X Ray (by selecting this profile, *Gamma* and *Color temperature* will be automatically set to *DICOM* and *Native* respectively)
- User 1
- User 2
- User 3

To select a profile

1. Bring up the OSD main menu.
2. Navigate to the *Picture* menu.
3. Enter the *Profile* submenu.
4. Select one of the available profiles and confirm.

5.1.2 Brightness

To adjust the brightness level

1. Bring up the OSD main menu.
2. Navigate to the *Picture* menu.
3. Enter the *Brightness* submenu.
The command bar *Brightness* is highlighted.
4. Set the brightness level as desired and confirm.



The selected brightness is maintained at a constant level by the automatic backlight stabilization function.



The brightness level can also be adjusted through a shortcut function.



Brightness level is adjusted by controlling the backlight illumination only.

5.1.3 Contrast

To adjust the contrast level

1. Bring up the OSD main menu.
2. Navigate to the *Picture* menu.
3. Enter the *Contrast* submenu.
The command bar *Contrast* is highlighted.
4. Set the contrast level as desired and confirm.

5.1.4 Saturation

To adjust the saturation level

1. Bring up the OSD main menu.
2. Navigate to the *Picture* menu.
3. Enter the *Saturation* submenu.
The command bar *Saturation* is highlighted.
4. Set the saturation level as desired and confirm.

5.1.5 Color temperature

About color temperature presets

The available color temperature presets for your display are:

- 5600K
- 6500K
- 7600K
- 9300K
- Native
- User



Factory calibration – White point:

The White Color points associated with the Color Temperature: 5600K, 6500K, 7600K or 9300K are factory calibrated with a consequent reduction of the maximum luminance compared to Native Color Temperature.



Only in case the User preset has been selected it is possible to get access to the color regulation commands to adjust the gain and offset of red, green and blue primary colors.

To select a color temperature preset

1. Bring up the OSD main menu.
2. Navigate to the *Picture* menu.

3. Enter the *Color Temperature* submenu.
4. Select one of the available color temperature presets and confirm.
Note: *If you selected the User color temperature preset, a new menu will be displayed allowing you to manually adjust the gain and offset of red, green and blue.*

5.1.6 Color space

About color space presets

The available color space presets for your display are:

- ITU709
- Native (wide color gamut close to DCI-P3)



Factory calibration – Color space:

When ITU 709 is selected, the White Color point and the RGB color primaries are adjusted according to the target HDTV / sRGB color space defined in the ITU-709 recommendation. RGB primary calibration is performed within the physical limitation of the LCD panel used.

To select a color space preset

1. Bring up the OSD main menu.
2. Navigate to the *Picture* menu.
3. Enter the *Color Space* submenu.
4. Select one of the available color space presets and confirm.

5.1.7 Gamma

About gamma presets

The available gamma presets for your display are:

- 1.8
- 2.2
- 2.4
- Video (transfer function adapted for video cameras with dark levels enhancement)
- Native (no correction curve is applied)
- DICOM (grayscale levels are following closely the DICOM curve – for reference only, not for diagnostic purposes)

To select a gamma preset

1. Bring up the OSD main menu.
2. Navigate to the *Picture* menu.
3. Enter the *Gamma* submenu.
4. Select one of the available gamma presets and confirm.

5.1.8 Sharpness

To adjust the sharpness level

1. Bring up the OSD main menu.
2. Navigate to the *Picture* menu.

5. Advanced operation

3. Enter the *Sharpness* submenu.
The command bar *Sharpness* is highlighted.
4. Set the sharpness level as desired and confirm.



Sharpness control is not available when DisplayPort mode *DP 1.1 dual* is selected (see "DisplayPort mode", page 28).

5.2 Picture advanced menu

5.2.1 Black Level

About black level

This command allows to add or subtract an offset to the input video signal (available only on video formats).

To adjust the black level

1. Bring up the OSD main menu.
2. Navigate to the *Picture advanced* menu.
3. Enter the *Black Level* submenu.
The command bar *Black Level* is highlighted.
4. Set the black level as desired and confirm.

5.2.2 Latency

About latency

The video latency is defined as the delay between the time of a monitor input video transition to the corresponding light output transition on screen.

The available latency modes for your display are:

- Diagnostic: Best picture quality
- Surgical: Lowest latency, optimized for fast moving images

To select the latency mode

1. Bring up the OSD main menu.
2. Navigate to the *Picture Advanced* menu.
3. Enter the *Latency* submenu.
4. Select one of the available latency modes and confirm.

5.2.3 Image Size

About image size

The available image sizes for your display are:

- Aspect (fill the screen on largest dimension, no modification in image aspect-ratio)
- Native (input pixel to LCD pixel mapping, no scaling)



In both Aspect and Native, the image may be displayed with black bars on top/bottom or left/right.

To select the image size

1. Bring up the OSD main menu.
2. Navigate to the *Picture Advanced* menu.
3. Enter the *Image Size* submenu.
4. Select one of the available image sizes and confirm.

5.2.4 Image Flip

About image flip

This function allows you to flip the image on your display.

The available options are:

- Disabled (no image flip applied)
- Mirror (flips the image horizontally, making the left content appear on the right and vice versa)
- Rotation (rotates the image 180°)



When image rotation is selected, the latency will increase with 20 msec. Image mirroring does not cause any latency increase.

To enable/disable horizontal flip

1. Bring up the OSD main menu.
2. Navigate to the *Picture Advanced* menu.
3. Enter the *Image Flip* submenu.
4. Select one of the available options and confirm.

5.2.5 Screen Resolution

About screen resolution

This function allows you to adjust the image resolution of the preferred timing detailed in the EDID exposed to the DP inputs and to the integrated Nexxis decoder.

The available options are:

- 4K (17:9) (for image resolution of 4096 x 2160)
- UHD (16:9) (for image resolution of 3840 x 2160)

To enable/disable horizontal flip

1. Bring up the OSD main menu.
2. Navigate to the *Picture Advanced* menu.
3. Enter the *Screen Resolution* submenu.
4. Select one of the available options and confirm.

5.3 Input select menu

5.3.1 Main Source

About main sources

The available main sources for your display are:

- DVI
- SDI
- DisplayPort
- Nexxis (MDSC-8231 MNA version only)



Available main source options may differ depending on display model.



The main source can also be quickly selected through the Input selection key (⏏), without the need to navigate through the OSD menu.

To select the main source

1. Bring up the OSD main menu.
2. Navigate to the *Input Select* menu.
3. Enter the *Main Source* submenu.
4. Select one of the available main sources and confirm.

5.3.2 DisplayPort mode

About DisplayPort mode

The available DisplayPort (DP) modes for your display are:

- DP 1.2 MST
- DP 1.1 main
- DP 1.1 dual



Please refer to the technical specifications for an overview of accepted video formats.

To select the DisplayPort mode

1. Bring up the OSD main menu.
2. Navigate to the *Input Select* menu.
3. Enter the *DP mode* submenu.
4. Select one of the available DisplayPort modes and confirm.

5.3.3 Auto search

About auto search

By enabling the input selection auto search function, the display will automatically detect the connected source and display it on the screen.

To enable/disable auto search

1. Bring up the OSD main menu.
2. Navigate to the *Input Select* menu.
3. Enter the *Auto search* submenu.
4. Enable/Disable auto search as desired and confirm.

5.3.4 Failover input

About failover input

This function allows the display to automatically switch to a failover (backup) source in case the Display-Port or Nexxis main source is missing. The display will automatically restore the main source once the signal is back.

The available failover inputs for your display are:

- None
- DVI
- SDI



The failover input can only be selected when both

1. the *Auto search* function is disabled (see "Auto search", page 29), and
2. the *2nd Picture Mode* function is disabled (see "2nd Picture Mode", page 30).

If any of both functions are enabled then failover will be disabled and made unavailable. As soon as both functions are disabled again, failover will be enabled and made available again with the selected failover input.



The failover input will be activated within about 7 seconds after the main input (Display-Port or Nexxis) has been lost.



During the transition from main to failover input and vice versa, a text message is visible to inform the user.



The main source can be changed while the failover input remains unchanged. During the selection and synchronization of a new main source the failover function is temporary (7 sec) disabled.

To select the failover input

1. Bring up the OSD main menu.
2. Navigate to the *Input Select* menu.
3. Enter the *Failover Input* submenu.

5. Advanced operation

4. Select one of the available failover inputs and confirm.

5.3.5 2nd Picture Mode

About 2nd picture modes

This function allows the display to show a second input source as an inset window inside the main source.

The available 2nd picture modes for your display are:

- Off
- Large PiP: 50% of display height in top-right corner
- Small PiP: 30% of display height in top-right corner

To select the 2nd picture mode

1. Bring up the OSD main menu.
2. Navigate to the *Input Select* menu.
3. Enter the *2nd Picture Mode* submenu.
4. Select one of the available 2nd picture modes and confirm.

5.3.6 2nd Picture Source

About 2nd picture sources

The available 2nd picture sources for your display are:

- DVI
- SDI



Independent Transfer Function:

Gamma and Color temperature for the 2nd Picture Source are always set to Native and 6500K independently from the Transfer Function applied to the Main Picture Source. For a perfect visualization of a DICOM image please select the DICOM input signal as Main picture and, if needed, the Video image as 2nd picture.

To select the 2nd picture source

1. Bring up the OSD main menu.
2. Navigate to the *Display Format* menu.
3. Enter the *2nd Picture Source* submenu.
4. Select one of the available 2nd picture sources and confirm.

5.4 Configuration menu

5.4.1 Information

About information

The available information items for your display are:

- Model (commercial type identification)
- Operating Hours (unit operation hours)
- Main board release (hardware and firmware identification)
- MNA release (firmware identification)
- Eth1 Main (IP address of Main ethernet (1) port of the monitor)
- Eth2 2nd (IP address of 2nd ethernet (2) port of the monitor)
- Keyboard release (hardware and firmware identification)
- SDI module release (hardware and firmware identification)
- Serial Number (unit serial number)
- Main FPGA release (firmware identification)

To access information

1. Bring up the OSD main menu.
2. Navigate to the *Configuration* menu.
3. Enter the *Information* submenu.
The different information items are shown.

5.4.2 Language

About languages

The available languages for your display OSD menu are:

- English
- Français
- Deutsch
- Español
- Italiano

To select the language

1. Bring up the OSD main menu.
2. Navigate to the *Configuration* menu.
3. Enter the *Language* submenu.
4. Select one of the available languages and confirm.

5.4.3 Source shortcut (Main source selection)

About the source shortcut

By default, the Source shortcut (⊖) allows to scroll through all the possible input sources and quickly select the main source, without the need to navigate through the OSD menu. This shortcut function can be disabled however to avoid unwanted or accidental switching of the main input source.

To enable/disable the source shortcut

1. Bring up the OSD main menu.
2. Navigate to the *Configuration* menu.
3. Enter the *Source shortcut* submenu.
4. Enable/Disable the main source shortcut as desired and confirm.

5.4.4 OSD setting

5.4.4.1 OSD Horizontal Position

To adjust the OSD horizontal position

1. Bring up the OSD main menu.
2. Navigate to the *Configuration* menu.
3. Enter the *OSD setting* submenu.
4. Select *OSD Hor. Pos.*
The command bar *OSD Hor. Pos.* is highlighted.
5. Set the OSD horizontal position as desired and confirm.

5.4.4.2 OSD Vertical Position

To adjust the OSD vertical position

1. Bring up the OSD main menu.
2. Navigate to the *Configuration* menu.
3. Enter the *OSD setting* submenu.
4. Select *OSD Ver. Pos.*
The command bar *OSD Ver. Pos.* is highlighted.
5. Set the OSD vertical position as desired and confirm.

5.4.4.3 OSD Time-out

About OSD time-out

The OSD menu can automatically close after a certain time of inactivity after the last selection was made.
The available OSD time-out values for your display are:

- 10 Sec.
- 20 Sec.
- 30 Sec.
- 60 Sec.
- Disabled (=5 minutes)

To adjust the OSD time-out

1. Bring up the OSD main menu.
2. Navigate to the *Configuration* menu.
3. Enter the *OSD setting* submenu.
4. Select *OSD Time-out*
5. Select one of the available OSD time-out values and confirm.

5.4.5 Recall Profile

About recalling profiles

To recall a profile means to restore the default factory settings (Factory and X Ray profiles) or recall the user defined profiles.

The available profiles to recall from your display are:

- Factory
- X Ray
- User 1
- User 2
- User 3

To recall a profile

1. Bring up the OSD main menu.
2. Navigate to the *Configuration* menu.
3. Enter the *Recall Profile* submenu.
4. Select one of the available profiles to recall and confirm.

5.4.6 Save Profile

About saving profiles

The user can modify the default video parameters associated to each profile and save the new parameter settings under the User 1, User 2 or User 3 profile. The Factory and X Ray profiles can be modified, but the factory default can't be overwritten and can always be recalled through the recall profile menu item.

The available profiles to save in your display are:

- User 1
- User 2
- User 3

To save a profile

1. Bring up the OSD main menu.
2. Navigate to the *Configuration* menu.
3. Enter the *Save Profile* submenu.
4. Select one of the available profiles to save and confirm.

5.5 System menu

5.5.1 Power on DVI

About power on DVI

This setting allows you to select the pin of the DVI connector on which the +5V DC supply is applied.

The available options are:

- Disabled
- +5V on Pin 14
- +5V on Pin 16

To select the power on DVI

1. Bring up the OSD main menu.
2. Navigate to the *System* menu.
3. Enter the *Power on DVI* submenu.

4. Select one of the available options and confirm.

5.5.2 Power on DisplayPort

About power on DisplayPort

This setting allows you to select if the +3V3 DC supply is applied on the DisplayPort connector or not.

The available options are:

- Disabled
- +3V3 on DP main

To select the power on DisplayPort

1. Bring up the OSD main menu.
2. Navigate to the *System* menu.
3. Enter the *Power on DP* submenu.
4. Select one of the available options and confirm.

5.5.3 OSD lock

About OSD locking

This setting allows you to avoid unwanted access to the OSD functions. By enabling the OSD lock, the OSD menu can only be accessed after pressing a sequence of keys. Please refer to "OSD menu locking/unlocking", page 21.

To enable/disable OSD locking

1. Bring up the OSD main menu.
2. Navigate to the *System* menu.
3. Enter the *OSD Lock* submenu.
4. Enable/Disable OSD locking as desired and confirm.

5.5.4 Power saving

About power saving

When the selected input(s) is (are) missing (main, 2nd and failover), this setting allows the display to switch off the backlight and enter a low power mode. As soon as the selected input(s) is (are) present again, the display will exit the power save mode and display the image. Also, by activating the OSD menu, the display will exit power save mode.



When the *Auto search* function is enabled (see "Auto search", page 29), the display will not enter the power save mode, even when the input(s) is (are) missing.

To enable/disable power saving

1. Bring up the OSD main menu.
2. Navigate to the *System* menu.
3. Enter the *Power Saving* submenu.
4. Enable/Disable power saving as desired and confirm.

5.5.5 DVI output

About DVI output

This setting allows to enable or disable the DVI output function of your display. Enabling DVI output will duplicate the entire image on the screen (including OSD) to a FHD (1080p/1080i) signal on the DVI output connector. For 4K images, the center part of the image will be down-scaled to FHD resolution.

To enable/disable DVI output

1. Bring up the OSD main menu.
2. Navigate to the *System* menu.
3. Enter the *DVI output* submenu.
4. Enable/Disable DVI output as desired and confirm.

6. IMPORTANT INFORMATION

6.1 Safety information

General recommendations

Read the safety and operating instructions before operating the device.

Retain safety and operating instructions for future reference.

Adhere to all warnings on the device and in the operating instructions manual.

Follow all instructions for operation and use.

Electrical Shock or Fire Hazard

To prevent electric shock or fire hazard, do not remove cover.

No serviceable parts inside. Refer servicing to qualified personnel.

Do not expose this apparatus to rain or moisture.

Modifications to the unit:

Do not modify this equipment without authorization of the manufacturer.

Preventive maintenance

Performance of preventive maintenance is not essential. Periodic maintenance inspections are essential to keep the monitor in optimum condition and ensure safe operation. We recommend a functional and safety test of the monitor at regular intervals (e.g. at least once a year).

Type of protection (Electrical)

Equipment with external power supply: Class I equipment

Degree of safety (flammable anesthetic mixture):

Equipment not suitable for use in the presence of a flammable anesthetic mixture with air or with oxygen or nitrous oxide.

Non-patient care equipment

- Equipment primarily for use in a health care facility that is intended for use where contact with a patient is unlikely (no applied part).
- The equipment may not be used with life support equipment.
- The user should not touch the equipment, nor its signal input ports (SIP)/signal output ports (SOP) and the patient at the same time.

Mission critical applications

We strongly recommend there is a replacement display immediately available in mission critical applications.

Use of electrical surgical knives

Provide as much distance as possible between the electrosurgical generator and other electronic equipment (such as monitors). An activated electrosurgical generator may cause interference with them. The interference can activate the OSD menu of the display and as such disrupt the functionality of the display.

Power connection – Equipment with external 24 VDC power supply

- Power requirements: The equipment must be powered using the delivered medical approved 24 VDC (—) SELV power supply.
- The medical approved DC (—) power supply must be powered by the AC mains voltage.
- The power supply is specified as a part of the ME equipment or combination is specified as a ME system.
- To avoid the risk of electric shock, this equipment must only be connected to a supply mains with protective earth.
- The equipment should be installed near an easily accessible outlet.
- The equipment is intended for continuous operation.

Power cords:

- Europe: H05VV-F or H05VVH2-F PVC cord with appropriate EU plug.
- US and Canada: “hospital grade” cord-set has to be used, provided with instructions to indicate that grounding reliability can be achieved only when the equipment is connected to an equivalent receptacle marked hospital only or hospital grade. These instructions need to be marked either on the equipment or on a tag on the power cord.

Transient over-voltage

If the device is not used for a long time, disconnect it from the AC inlet to avoid damage by transient over-voltage.

To fully disengage the power to the device, please disconnect the power cord from the AC inlet.

Connections

Any external connection with other peripherals must follow the requirements of clause 16 of IEC60601-1 3rd ed. or Table BBB.201 of IEC 60601-1-1 for the medical electrical systems.

Water and moisture

The equipment is IP20 compliant. The monitor front side only is IP45 compliant. The PSU only is IP22 compliant.

Moisture condensation

Do not use monitor under rapid temperature and humidity change condition or avoid cold air from air-conditioning outlet directly.

Moisture may condense on the surface or inside of the unit, or create a mist residue inside the protection plate, this is not a malfunction of the product itself, although it may cause damage to the monitor.

If condensation happens, let the monitor stand unplugged until there is no condensation.

Ventilation

Do not cover or block any ventilation openings in the cover of the set. When installing the device in a cupboard or another enclosed location, heed the necessary space between the set and the sides of the cupboard.

Installation

- Place the equipment on a flat, solid and stable surface that can support the weight of at least 3 units. If you use an unstable cart or stand, the equipment may fall, causing serious injury to a child or adult, and serious damage to the equipment.
- Do not allow to climb or rest on the equipment.
- When adjusting the angle of the equipment, move it slowly so as to prevent the equipment from moving from or slipping off its stand or arm.
- When the equipment is attached to an arm, do not use the equipment as a handle or grip in order to move the equipment. Please refer to the instruction manual of the arm for instructions on how to move the arm with the equipment.
- Provide full attention to safety during installation, periodic maintenance and examination of this equipment.
- Sufficient expertise is required for installing this equipment, especially to determine the strength of the wall, arm or ceiling suspension for withstanding the display's weight. Be sure to entrust the attachment of this equipment to the wall to a duly skilled technician and pay adequate attention to safety during the installation and usage.
- The manufacturer is not liable for any damage or injury caused by mishandling or improper installation.

General warnings

- All devices and complete setup must be tested and validated before taking into operation.
- At end user application level it is necessary to foresee a backup unit in case the monitor fails.

Technical data

- The monitor is intended for indoor use
- The monitor has been designed to be used in landscape position with a tilt of -10° (backward) and $+10^{\circ}$ (forward)
- Class I Equipment, according to the type of protection against electric shock
- The monitor is not intended to be sterilized
- The monitor has no applied parts. The front side of the monitor and the plastic enclosure have been treated as applied parts however, because they may accidentally be touched by the patient for a time <1 minute.
- The compliance of this display with Medical Safety and EMC requirements has been evaluated using the external (optional) medical power supply model 'XP Power AHM250PS24T'. If a different power supply will be used, further investigation for Safety and EMC requirements have to be performed at system level.
- The enclosure has to be checked upon collision damage, refer to qualified service personnel

This apparatus conforms to:

Medical Equipment:

- IEC 60601-1: 2012 Edition 3.1 (Medical electrical equipment – Part 1: General requirements for basic safety and essential performance)
- EN 60601-1: 2006 +A1:2013 (Medical electrical equipment". Part 1: General requirements basic safety and essential performance)
- ANSI/AAMI ES 60601-1: 2005/(R)2012 and A1:2012, C1:2009/(R)2012 and A2:2010/(R)2012 - Med. El. Equip., Part 1: general req. for basic safety and essential performance.
- CAN/CSA-C22.2 No. 60601-1: 14 Medical Electrical Equipment - Part 1: General Requirements for Basic Safety and Essential Performance (Harmonized with Ed. 3.1)

EMC:

- IEC / EN 60601-1-2: 2007
- EN 55011 / CISPR11 (MDSC-8231: Class B)

6. Important information

National Scandinavian Deviations for CL 1.7.2:

Finland: "Laitte on liitettävä suojamaadoituskoskettimilla varustettuun pistorasiaan"

Norway: "Apparatet må tilkoples jordet stikkontakt"

Sweden: "Apparaten skall anslutas till jordat uttag"

6.2 Environmental information

Disposal Information

Waste Electrical and Electronic Equipment



■ This symbol on the product indicates that, under the European Directive 2012/19/EU governing waste from electrical and electronic equipment, this product must not be disposed of with other municipal waste. Please dispose of your waste equipment by handing it over to a designated collection point for the recycling of waste electrical and electronic equipment. To prevent possible harm to the environment or human health from uncontrolled waste disposal, please separate these items from other types of waste and recycle them responsibly to promote the sustainable reuse of material resources.

For more information about recycling of this product, please contact your local city office or your municipal waste disposal service.

For details, please visit the Barco website at: <http://www.barco.com/en/AboutBarco/weee>

Turkey RoHS compliance



■ Türkiye Cumhuriyeti: AEEE Yönetmeliğine Uygundur.

[Republic of Turkey: In conformity with the WEEE Regulation]

中国大陆 RoHS

Chinese Mainland RoHS

根据中国大陆《电器电子产品有害物质限制使用管理办法》(也称为中国大陆RoHS), 以下部分列出了Barco产品中可能包含的有毒和/或有害物质的名称和含量。中国大陆RoHS指令包含在中国信息产业部MCV标准:“电子信息产品中有毒物质的限量要求”中。

According to the “Management Methods for the Restriction of the Use of Hazardous Substances in Electrical and Electronic Products” (Also called RoHS of Chinese Mainland), the table below lists the names and contents of toxic and/or hazardous substances that Barco’s product may contain. The RoHS of Chinese Mainland is included in the MCV standard of the Ministry of Information Industry of China, in the section “Limit Requirements of toxic substances in Electronic Information Products”.

零件项目(名称) Component name	有毒有害物质或元素 Hazardous substances and elements					
	铅 Pb	汞 Hg	镉 Cd	六价铬 Cr6+	多溴联苯 PBB	多溴二苯醚 PBDE
印制电路配件 Printed Circuit Assemblies	X	○	○	○	○	○

零件项目(名称) Component name	有毒有害物质或元素 Hazardous substances and elements					
	铅 Pb	汞 Hg	镉 Cd	六价铬 Cr6+	多溴联苯 PBB	多溴二苯醚 PBDE
液晶面板 LCD panel	X	O	O	O	O	O
外接电(线)缆 External Cables	X	O	O	O	O	O
内部线路 Internal wiring	O	O	O	O	O	O
金属外壳 Metal enclosure	O	O	O	O	O	O
塑胶外壳 Plastic enclosure	O	O	O	O	O	O
散热片(器) Heatsinks	O	O	O	O	O	O
风扇 Fan	O	O	O	O	O	O
电源供应器 Power Supply Unit	X	O	O	O	O	O
文件说明书 Paper Manuals	O	O	O	O	O	O
光盘说明书 CD manual	O	O	O	O	O	O
本表格依据SJ/T 11364的规定编制 This table is prepared in accordance with the provisions of SJ/T 11364. O: 表示该有毒有害物质在该部件所有均质材料中的含量均在 GB/T 26572 标准规定的限量要求以下。 O: Indicates that this toxic or hazardous substance contained in all of the homogeneous materials for this part is below the limit requirement in GB/T 26572. X: 表示该有毒有害物质至少在该部件的某一均质材料中的含量超出 GB/T 26572 标准规定的限量要求。 X: Indicates that this toxic or hazardous substance contained in at least one of the homogeneous materials used for this part is above the limit requirement in GB/T 26572.						

在中国大陆销售的相应电子信息产品(EIP)都必须遵照中国大陆《电子电气产品有害物质限制使用标识要求》标准贴上环保使用期限(EFUP)标签。Barco产品所采用的EFUP标签(请参阅实例,徽标内部的编号用于指定产品)基于中国大陆的《电子信息产品环保使用期限通则》标准。

All Electronic Information Products (EIP) that are sold within Chinese Mainland must comply with the "Marking for the restriction of the use of hazardous substances in electrical and electronic product" of Chinese Mainland, marked with the Environmental Friendly Use Period (EFUP) logo. The number inside the EFUP logo that Barco uses (please refer to the photo) is based on the "General guidelines of environment-friendly use period of electronic information products" of Chinese Mainland.



6. Important information

RoHS

Directive 2011/65/EC on the restriction of certain hazardous substances in electrical and electronic equipment.

According to what declared by our components suppliers, this product is RoHS compliant.

6.3 Biological hazard and returns

Overview

The structure and the specifications of this device as well as the materials used for manufacturing makes it easy to wipe and clean and therefore suitable to be used for various applications in hospitals and other medical environments, where procedures for frequent cleaning are specified.

However, normal use shall exclude biological contaminated environments, to prevent spreading of infections.

Therefore use of this device in such environments is at the exclusive risk of Customer. In case this device is used where potential biological contamination cannot be excluded.

Customer shall implement the decontamination process as defined in the latest edition of the ANSI/AAMI ST35 standard on each single failed Product that is returned for servicing, repair, reworking or failure investigation to Seller (or to the Authorized Service Provider). At least one adhesive yellow label shall be attached on the top site of the package of returned Product and accompanied by a declaration statement proving the Product has been successfully decontaminated.

Returned Products that are not provided with such external decontamination label, and/or whenever such declaration is missing, can be rejected by Seller (or by the Authorized Service Provider) and shipped back at Customer expenses.

6.4 Regulatory compliance information

Indications for use

This device is intended to be used in operation rooms, to display images from endoscopic cameras, room and boom cameras, ultrasound, cardiology, PACS, anesthesiology and patient information. It is not intended for diagnosis.

FCC class B

This device complies with Part 15 of the FCC Rules. Operation is subject to the following two conditions: (1) this device may not cause harmful interference, and (2) this device must accept any interference received, including interference that may cause undesired operation.

This device has been tested and found to comply with the limits for a Class B digital device, pursuant to Part 15 of the FCC Rules. These limits are designed to provide reasonable protection against harmful interference in a residential installation. This device generates, uses and can radiate radio frequency energy and, if not installed and used in accordance with the instructions, may cause harmful interference to radio communications. However, there is no guarantee that interference will not occur in a particular installation. If this device does cause harmful interference to radio or television reception, which can be determined by turning the device off and on, the user is encouraged to try to correct the interference by one or more of the following measures:

- Reorient or relocate the receiving antenna.
- Increase the separation between the device and receiver.
- Connect the device into an outlet on a circuit different from that to which the receiver is connected.
- Consult the dealer or an experienced radio/TV technician for help.

Changes or modifications not expressly approved by the party responsible for compliance could void the user's authority to operate the equipment.

Canadian notice

CAN ICES-1/NMB-1

6.5 Cleaning and disinfection

Instructions

- Be sure to unplug the power cord from the mains when cleaning your LCD monitor.
- Take care not to scratch the front surface with any hard or abrasive material.
- Dust, finger marks, grease etc. can be removed with a soft damp cloth (a small amount of mild detergent can be used on the damp cloth).
- Wipe off water drop immediately.





Possible cleaning solutions

- 250 ppm chlorine solution
- NaCl solution 0.9% – Sodim chloride 00-236
- Bacillol AF
- 1.6 percent aqueous ammonia
- Cidex® (2.4 percent glutaraldehyde solution)
- Sodium hypochlorite (bleach) 10 percent
- "Green soap" (USP)
- Like Cleansafe® optical cleaning liquid
- Isopropanol
- Haemosol solution (1% in 1 liter water)
- Chlorhexidine 0,5% in 70% Ethanol















6.6 Explanation of symbols

Symbols on the device





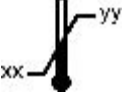



On the device or power supply, you may find the following symbols (nonrestrictive list):

	Indicates the device meets the requirements of the applicable EC directives.
	Indicates compliance with Part 15 of the FCC rules (Class A or Class B)
	Indicates the device is approved according to the UL Recognition regulations
	Indicates the device is approved according to the UL regulations for Canada and US

6. Important information

	Indicates the device is approved according to the UL Demko regulations
	Indicates the device is approved according to the CCC regulations
	Indicates the device is approved according to the VCCI regulations
	Indicates the device is approved according to the KC regulations
	Indicates the device is approved according to the BSMI regulations
	Indicates the device is approved according to the PSE regulations
	Caution: Federal law (United States of America) restricts this device to sale by or on the order of a licensed healthcare practitioner.
IS 13252 (Part 1) IEC 60950-1  R-xxxxxxx	Indicates the device is approved according to the BIS regulations
	Indicates the USB connectors on the device
	Indicates the DisplayPort connectors on the device
	Indicates the legal manufacturer
	Indicates the manufacturing date
	Indicates the temperature limitations ¹ for the device to safely operate within specs.
	Indicates the device serial number

¹. Values for xx and yy can be found in the technical specifications paragraph.

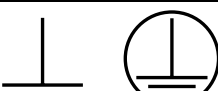
	Indicates the device part number or catalogue number
	Warning: dangerous voltage
	Caution
	Consult the operating instructions
	Indicates this device must not be thrown in the trash but must be recycled, according to the European WEEE (Waste Electrical and Electronic Equipment) directive
	Indicates Direct Current (DC)
	Indicates Alternating Current (AC)
	Stand-by
	Equipotentiality
	Protective earth (ground)

6.7 Legal disclaimer

Disclaimer notice

Although every attempt has been made to achieve technical accuracy in this document, we assume no responsibility for errors that may be found. Our goal is to provide you with the most accurate and usable documentation possible; if you discover errors, please let us know.

Barco software products are the property of Barco. They are distributed under copyright by Barco NV or Barco Inc., for use only under the specific terms of a software license agreement between Barco NV or Barco Inc. and the licensee. No other use, duplication, or disclosure of a Barco software product, in any form, is authorized.

The specifications of Barco products are subject to change without notice.

Trademarks

All trademarks and registered trademarks are property of their respective owners.

6. Important information

Copyright notice

This document is copyrighted. All rights are reserved. Neither this document, nor any part of it, may be reproduced or copied in any form or by any means - graphical, electronic, or mechanical including photocopying, taping or information storage and retrieval systems - without written permission of Barco.

© 2016 Barco NV all rights reserved.

6.8 Technical specifications

MDSC-8231 LED

Screen technology	TFT AM LCD / IPS-PRO technology / LED backlight
LCD panel active screen size (diagonal)	31.1" / 789 mm
LCD panel active screen size (H x V)	698 x 368 mm
LCD panel aspect ratio (H:V)	17:9
LCD panel resolution	4k-2k (4096 x 2160)
Pixel pitch	0.1704 mm
Color support	1073 million (10-bit)
Color gamut	Native: Wide color gamut (96% DCI-P3) Default setting: ITU 709 standard
Viewing angle (H, V)	178° Hor / 178° Ver
Luminance	Native: 550 cd/m ² (Typical) Default setting: 450 cd/ m ² @6500K stabilized
Backlight sensor	Automatic backlight stabilization
Contrast ratio	1400:1 (typical)
LCD response time (Tr + Tf)	20 ms (typical)
White point	Native: 7200K (Typical) Calibrated: 5600K, 6500K, 7600K, 9300K
Gamma	Native, 1.8, 2.2, 2.4, DICOM, Video
Housing color	RAL 9003
Screen protection	2-side anti-reflective alkali-aluminosilicate glass
Keyboard	Capacitive touch keyboard
Video input signals	4K-UHD input <ul style="list-style-type: none">• 1x DP 1.1 up to 4096 x 2160 @30Hz• 2x DP 1.1 up to 2048 x 2160 @50Hz/60Hz• 1x DP 1.2 MST up to 4096 x 2160 @50Hz/60Hz FHD input (upscaled to UHD) <ul style="list-style-type: none">• 1x DVI• 1x 3G-SDI
Video output signals	1x 3G-SDI (3G-SDI input loopthrough) 1x DVI (image on screen downscaled to FHD)
Remote control	MicroUSB port for FW download & control protocol
Power consumption (nominal)	110W / 24V ± 10%

External power supply	AC input: 100 – 250 VAC / 47-63 Hz auto-switch DC output: +24 VDC / 10 A Max power out: 250 W
DC power output	DVI connector: +5V on pin 14 & 16 / 500mA DP connector: +3.3V / 500mA
Power management	Low power mode: 18W (typical) Power-off: ~ 1 W
Dimensions display (W x H x D)	777 x 472 x 93 mm (30.6 x 18.6 x 3.7 in)
Net weight display	12.1 kg (26.6 lbs)
Net weight packaged	17.0 kg (37.5 lbs)
Mounting standard	VESA (100 x 100 mm, 200 x 100 mm)
Certifications	<ul style="list-style-type: none"> • ANSI/AAMI ES 60601-1:2005/(R)2012 and A1:2012, C1:2009/(R)2012 and A2:2010/(R)2012 - Med. El. Equip., Part 1: general req. for basic safety and essential performance • CAN/CSA-C22.2 No. 60601-1: 14 Medical Electrical Equipment - Part 1: General Requirements for Basic Safety and Essential Performance (Harmonized with Ed. 3.1) • IEC 60601-1: 2012 Edition 3.1 (Medical electrical equipment – Part 1: General requirements for basic safety and essential performance) • EN 60601-1: 2006 + A1:2013 (Medical electrical equipment - Part 1: General requirements for safety) • Electromagnetic Compatibility: EMC Medical EMC Standards: IEC60601-1-2, EN55011 /CISPR 11, FCC CFR47 part 15 & 18/Class B • Approvals/Marking: CE, c-UL-us, DEMKO • ROHS-2, REACH, WEEE compliant
Operating temperature	0 ÷ 35 °C (for performance); 0 ÷ 40 °C (for safety)
Storage temperature	-20 ÷ +60°C
Operating humidity	10 ÷ 90% (non-condensing)
Storage humidity	5 ÷ 90% (non-condensing)

MDSC-8231 MNA

Screen technology	TFT AM LCD / IPS-PRO technology / LED backlight
LCD panel active screen size (diagonal)	31.1" / 789 mm
LCD panel active screen size (H x V)	698 x 368 mm
LCD panel aspect ratio (H:V)	17:9
LCD panel resolution	4k-2k (4096 x 2160)
Pixel pitch	0.1704 mm
Color support	1073 million (10-bit)
Color gamut	Native: Wide color gamut (96% DCI-P3) Default setting: ITU 709 standard
Viewing angle (H, V)	178° Hor / 178° Ver
Luminance	Native: 550 cd/m ² (Typical) Default setting: 450 cd/ m ² @6500K stabilized
Backlight sensor	Automatic backlight stabilization
Contrast ratio	1400:1 (typical)

6. Important information

LCD response time (Tr + Tf)	20 ms (typical)
White point	Native: 7200K (Typical)
	Calibrated: 5600K, 6500K, 7600K, 9300K
Gamma	Native, 1.8, 2.2, 2.4, DICOM, Video
Housing color	RAL 9003
Screen protection	2-side anti-reflective alkali-aluminosilicate glass
Keyboard	Capacitive touch keyboard
Video input signals	4K-UHD input
	<ul style="list-style-type: none"> • 1x DP 1.1 up to 4096 x 2160 @30Hz • 2x DP 1.1 up to 2048 x 2160 @50Hz/60Hz • 1x DP 1.2 MST up to 4096 x 2160 @50Hz/60Hz
	2x FO SFP+ for 4K-UHD Nexxis link
	FHD input (upscaled to UHD)
Video output signals	1x 3G-SDI (3G-SDI input loopthrough)
	1x DVI (image on screen downscaled to FHD)
Integrated Nexxis 4k decoder	MNA-240 Decoder integrated
Remote control	FW download & control protocol through network connection
Power consumption (nominal)	140W / 24V ± 10%
External power supply	AC input: 100 – 250 VAC / 47-63 Hz auto-switch
	DC output: +24 VDC / 10 A
	Max power out: 250 W
DC power output	DVI connector: +5V on pin 14 & 16 / 500mA
	DP connector: +3.3V / 500mA
	USB connector: +5V / 1A
Power management	Low power mode: 52W (typical)
	Power-off: ~ 1 W
Dimensions display (W x H x D)	777 x 472 x 93 mm (30.6 x 18.6 x 3.7 in)
Net weight display	12.7 kg (28.0 lbs)
Net weight packaged	17.5 kg (38.6 lbs)
Mounting standard	VESA (100 x 100 mm, 200 x 100 mm)
Certifications	<ul style="list-style-type: none"> • ANSI/AAMI ES 60601-1:2005/(R)2012 and A1:2012, C1:2009/(R)2012 and A2:2010/(R)2012 - Med. El. Equip., Part 1: general req. for basic safety and essential performance • CAN/CSA-C22.2 No. 60601-1: 14 Medical Electrical Equipment - Part 1: General Requirements for Basic Safety and Essential Performance (Harmonized with Ed. 3.1) • IEC 60601-1: 2012 Edition 3.1 (Medical electrical equipment – Part 1: General requirements for basic safety and essential performance) • EN 60601-1: 2006 + A1:2013 (Medical electrical equipment - Part 1: General requirements for safety) • Electromagnetic Compatibility: EMC Medical EMC Standards: IEC60601-1-2, EN55011 /CISPR 11, FCC CFR47 part 15 & 18/Class B • Approvals/Marking: CE, c-UL-us, DEMKO • ROHS-2, REACH, WEEE compliant

Operating temperature	0 ÷ 35 °C (for performance); 0 ÷ 40 °C (for safety)
Storage temperature	-20 ÷ +60°C
Operating humidity	10 ÷ 90% (non-condensing)
Storage humidity	5 ÷ 90% (non-condensing)

Dimensions

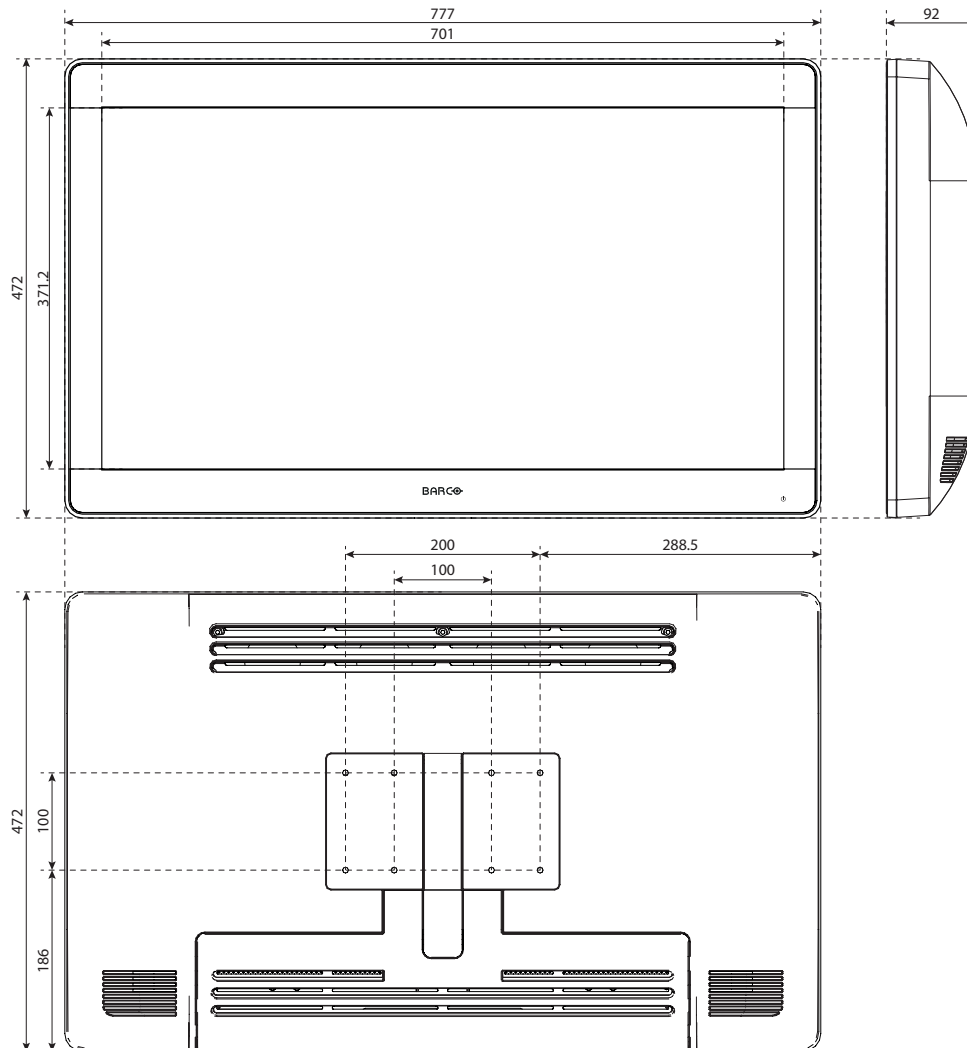

Image 6-1