

Preface

About this Manual

- The contents of this manual and the bundled Basic Reference are subject to change without notice.
- Note that the example screens and product illustrations shown in this User's Guide may differ somewhat from the screens and configuration of the actual camera.

Copyright

This manual contains proprietary information protected by copyright. All rights are reserved. No part of this manual may be reproduced by any mechanical, electronic or other means, in any form, without prior written permission of the manufacturer.

© Copyright 2015

Declaration of Conformity

This device complies with Part 15 of the FCC rules. Operation is subject to the following conditions:

- This device may not cause harmful interference.
- This device must accept any interference received, including interference that may cause undesired operation.

CE Mark Warning

This is a Class B product, in a domestic environment, this product may cause radio interference, in which case the user may be required to take adequate measures.

FCC: SAR standard Value: 1.6 W/Kg, Maximal Measure: 0.27 W/Kg

CE: SAR standard Value: 2.0 W/Kg, Maximal Measure: 0.077 W/Kg

Trademark Recognition

Windows XP/Vista/Win7/Win 8 are registered trademarks of Microsoft Corporation in the United States and/or other countries. Windows is an abbreviated term referring to the Microsoft Windows Operation System. All other companies or product names are trademarks or registered trademarks of their respective companies.

Federal Communication Commission Interference Statement

APPLIES TO USA AND CANADA ONLY

This device complies with Part 15 of the FCC Rules. Operation is subject to the following two conditions: (1) This device may not cause harmful interference, and (2) this device must accept any interference received, including interference that may cause undesired operation.

This equipment has been tested and found to comply with the limits for a Class B digital device, pursuant to Part 15 of the FCC Rules. These limits are designed to provide reasonable protection against harmful interference in a residential installation. This equipment generates, uses and can radiate radio frequency energy and, if not installed and used in accordance with the instructions, may cause harmful interference to radio communications. However, there is no guarantee that interference will not occur in a particular installation. If this equipment does cause harmful interference to radio or television reception, which can be determined by turning the equipment off and on, the user is encouraged to try to correct the interference by one of the following measures:

- *Reorient or relocate the receiving antenna.*
- *Increase the separation between the equipment and receiver.*
- *Connect the equipment into an outlet on a circuit different from that to which the receiver is connected.*
- *Consult the dealer or an experienced radio/TV technician for help.*

FCC Caution: Any changes or modifications not expressly approved by the party responsible for compliance could void the user's authority to operate this equipment.

This transmitter must not be co-located or operating in conjunction with any other antenna or transmitter.

Radiation Exposure Statement:

This equipment complies with FCC radiation exposure limits set forth for an uncontrolled environment. This equipment should be installed and operated with minimum distance 20cm between the radiator & your body.

This device is intended only for OEM integrators under the following conditions:

- 1) *The antenna must be installed such that 20 cm is maintained between the antenna and users, and*
- 2) *The transmitter module may not be co-located with any other transmitter or antenna.*

As long as 2 conditions above are met, further transmitter test will not be required. However, the OEM integrator is still responsible for testing their

end-product for any additional compliance requirements required with this module installed.

IMPORTANT NOTE: *In the event that these conditions can not be met (for example certain laptop configurations or co-location with another transmitter), then the FCC authorization is no longer considered valid and the FCC ID can not be used on the final product. In these circumstances, the OEM integrator will be responsible for re-evaluating the end product (including the transmitter) and obtaining a separate FCC authorization.*

End Product Labeling

This transmitter module is authorized only for use in device where the antenna may be installed such that 20 cm may be maintained between the antenna and users. The final end product must be labeled in a visible area with the following: "Contains FCC ID: 2AAD3AA0D0". The grantee's FCC ID can be used only when all FCC compliance requirements are met.

Manual Information To the End User

The OEM integrator has to be aware not to provide information to the end user regarding how to install or remove this RF module in the user's manual of the end product which integrates this module.

The end user manual shall include all required regulatory information/warnings as shown in this manual.

Industry Canada statement

This device complies with RSS-210 of the Industry Canada Rules. Operation is subject to the following two conditions: (1) This device may not cause harmful interference, and (2) this device must accept any interference received, including interference that may cause undesired operation.

Ce dispositif est conforme à la norme CNR-210 d'Industrie Canada applicable aux appareils radio exempts de licence. Son fonctionnement est sujet aux deux conditions suivantes: (1) le dispositif ne doit pas produire de brouillage préjudiciable, et (2) ce dispositif doit accepter tout brouillage reçu, y compris un brouillage susceptible de provoquer un fonctionnement indésirable.

This device is intended only for OEM integrators under the following conditions: (For module device use)

- 1) The antenna must be installed such that 20 cm is maintained between the antenna and users, and*
- 2) The transmitter module may not be co-located with any other transmitter or antenna.*

As long as 2 conditions above are met, further transmitter tests will not be required. However, the OEM integrator is still responsible for testing their end-product for any additional compliance requirements required with this module installed.

Cet appareil est conçu uniquement pour les intégrateurs OEM dans les conditions suivantes: (Pour utilisation de dispositif module)

- 1) L'antenne doit être installée de telle sorte qu'une distance de 20 cm est respectée entre l'antenne et les utilisateurs, et*
- 2) Le module émetteur peut ne pas être coïmplanté avec un autre émetteur ou antenne.*

Tant que les 2 conditions ci-dessus sont remplies, des essais supplémentaires sur l'émetteur ne seront pas nécessaires. Toutefois, l'intégrateur OEM est toujours responsable des essais sur son produit final pour toutes exigences de conformité supplémentaires requis pour ce module installé.

IMPORTANT NOTE: *In the event that these conditions can not be met (for example certain laptop configurations or co-location with another transmitter), then the Canada authorization is no longer considered valid and the IC ID can not be used on the final product. In these circumstances, the OEM integrator will be responsible for re-evaluating the end product (including the transmitter) and obtaining a separate Canada authorization.*

NOTE IMPORTANTE : *Dans le cas où ces conditions ne peuvent être satisfaites (par exemple pour certaines configurations d'ordinateur portable ou de certaines co-localisation avec un autre émetteur), l'autorisation du Canada n'est plus considéré comme valide et l'ID IC ne peut pas être utilisé sur le produit final. Dans ces circonstances, l'intégrateur OEM sera chargé de réévaluer le produit final (y compris l'émetteur) et l'obtention d'une autorisation distincte au Canada.*

End Product Labeling

This transmitter module is authorized only for use in this device where the antenna may be installed such that 20 cm may be maintained between the antenna and users. The final end product must be labeled in a visible area with the following: "Contains IC: 10290A-AA0D0".

Plaque signalétique du produit final

Ce module émetteur est autorisé uniquement pour une utilisation dans un dispositif où l'antenne peut être installée de telle sorte qu'une distance de 20cm peut être maintenue entre l'antenne et les utilisateurs. Le produit final doit être étiqueté dans un endroit visible avec l'inscription suivante: "Contient des IC: 10290A-AA0D0".

Manual Information To the End User

The OEM integrator has to be aware not to provide information to the end user regarding how to install or remove this RF module in the user's manual of the end product which integrates this module.

The end user manual shall include all required regulatory information/warning as shown in this manual.

Manuel d'information à l'utilisateur final

L'intégrateur OEM doit être conscient de ne pas fournir des informations à l'utilisateur final quant à la façon d'installer ou de supprimer ce module RF dans le manuel de l'utilisateur du produit final qui intègre ce module.

Le manuel de l'utilisateur final doit inclure toutes les informations réglementaires requises et avertissements comme indiqué dans ce manuel.

Safety and Handling Precautions

Camera Information

- Do not take apart or attempt to service the camera yourself.
- Do not expose the camera to moisture, or extreme temperatures.
- Allow the camera to warm up when moving from cold to warm temperatures.
- Do not touch and put pressure on the camera lens.
- Do not expose the lens to direct sunlight for extended periods.
- Do not use abrasive chemicals, cleaning solvents or strong detergents to clean the product. Wipe the product with a slightly damp soft cloth.
- Do not use the flash or LED Light near a person's eyes to prevent possible eye injury.
- Please do not use the camera while you are walking, driving or riding a vehicle.
- Please handle the camera strap with care, and never place the strap around the neck of an infant or child. Wrapping the strap around a neck may cause suffocation.
- Do not subject the LCD monitor to impact.
- To prevent the risk of fire or electric shock, do not expose this appliance to rain or moisture.

Battery Information

- Turn off the camera before installing or removing the battery.
- Use only the provided batteries or type of battery and charger that came with your camera. Using other types of batteries or chargers may damage the device and invalidate the warranty.
- Inserting the battery upside down can cause damage to the product and possibly cause an explosion.
- When the camera is used for an extended period of time, it is normal for the camera body to feel warm.
- Download all pictures and remove the battery from the camera if you are going to store the camera for a long period of time.

- The type of battery and the battery power level may cause the lens to stick. Ensure you use the correct battery type and use a fully charged battery.
- Risk of explosion if replace with an incorrect battery. Dispose of used batteries according to the instructions.
- Please keep the batteries out of the reach of children to prevent from swallowing batteries, which might cause poisoning.

USB adapter Information

- Do not expose the adapter to high temperatures or places with high levels of moisture. Otherwise, it may cause fire or electric shock.
- Do not attempt to repair, disassemble, change or transform the adapter.
- Avoid sudden changes in temperature, which may cause condensation on the adapter's internal surfaces. Please do not use it immediately in this situation.
- Do not touch the plug with wet hands otherwise it may cause an electric shock.
- Do not use the travel voltage converter or AC/DC power inverter. Otherwise, it may cause damage, overheating, malfunction or fire to the camera.

Using this Menu

Symbols used in this manual are explained below:



	This indicates useful information when using your camera.
	This indicates important message that should be read before using the function.

Table of Contents

Preface	1
About this Manual	1
<i>Federal Communication Commission Interference Statement</i>	2
<i>Industry Canada statement</i>	3
Safety and Handling Precautions	5
Using this Menu	6
Introduction	10
System Requirements	10
Main Features	10
Package Contents	11
Camera Views	12
Camera Buttons	14
Navigation Control	15
Getting Started	17
Inserting the Battery	17
Camera Memory	18
Inserting an SD/SDHC/SDXC Memory Card	19
Charging the Battery by USB	20
Turning the Power On and Off	20
Initial Settings	21
Modes	21
Using the LCD monitor	22
LCD Monitor Layout	22
Recording Images and Videos	27
Taking Images	27
Setting the Zoom Control	27
Using the AE/AF LOCK/UP Button	28
Using Flash	29

Setting the Focus Mode	30
Setting Continuous Shooting.....	31
Using the Function Menu/Delete Button	32
Using the Movie Menu.....	37
Recording Videos	41
Using the Record Menu	51
Playback	59
Viewing in Single Navigation.....	59
Viewing Thumbnails.....	59
Magnify	60
Playing Videos	62
Playing Voice Memo	63
Playback Menu.....	64
Using the Setup Menu.....	75
Setting Sounds	75
Setting Power Save	76
Setting Date & Time.....	76
Setting Language.....	77
Setting Display Mode.....	77
Setting TV Out.....	77
Setting LCD Brightness.....	78
Setting Format.....	78
Reset All.....	78
Making Connections.....	79
Connecting the Camera to a TV	79
Connecting the Camera to a PC	79
Connecting the Camera to a Printer	80
Setting the Print Mode Menu	81
Appendix.....	82

About Folder and File Names	82
Troubleshooting.....	82
Specifications	84

Introduction

Congratulations on your purchase of the new digital camera.

Capturing high-quality digital images is fast and easy with this state-of-the-art smart camera.

System Requirements

In order to get the most out of your camera, your computer must meet the following system requirements:

For Windows:

- Windows XP/Vista/Win7/Win8
- Processor: Intel Pentium D 3.0GHz or equivalent AMD Athlon, or faster
- Memory: 2 GB or above
- HDD space: 300MB or above
- 32bit color display monitor
- Microsoft DirectX 9.0C
- USB port and CD-ROM drive

For Macintosh:

- Mac OS 10.3.9 ~ 10.8 <Digital Camera>
- Memory: 1 GB or above
- Q. Time player ver. 6.0.3 or above
- USB port and CD-ROM drive

Main Features

- 20 mega pixels resolution
- Up to 5x optical zoom and 8x digital zoom
- 2.7 inch color LCD monitor
- 64MB internal flash memory with optional external SD/SDHC/SDXC card
- Supports up to 4GB of SD card, and up to 32GB of SDHC card and to 64GB of SDXC card
- Easy-to-use button interface
- DCF, DPOF, PictBridge compatibility
- Slide show enables you to playback photos, videos and corrupted files
- A/V output to view your images and videos on your TV
- USB port to transfer images and videos to your PC

Package Contents

Please check the contents of your camera package. It should contain:

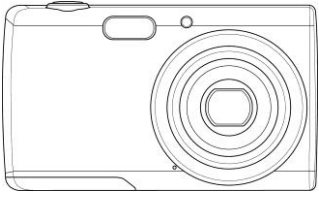

Digital camera

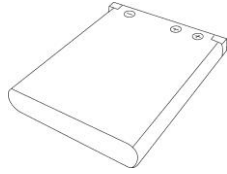

Rechargeable battery
x 1 pcs

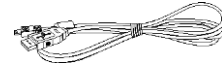

USB cable



Wrist strap

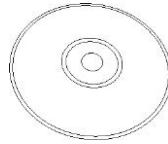

CD-Rom

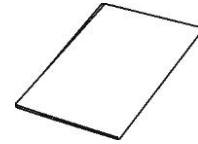

Quick Start Guide

Camera Views

Front View

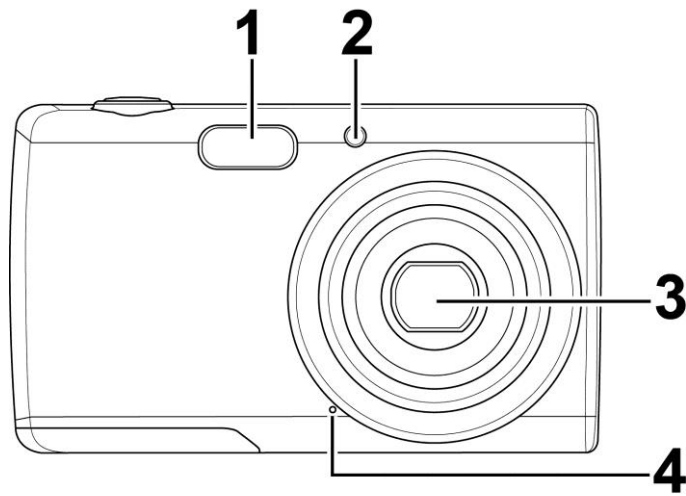

- 1. Flash
- 2. Self-timer LED
- 3. Lens
- 4. Microphone

Back View

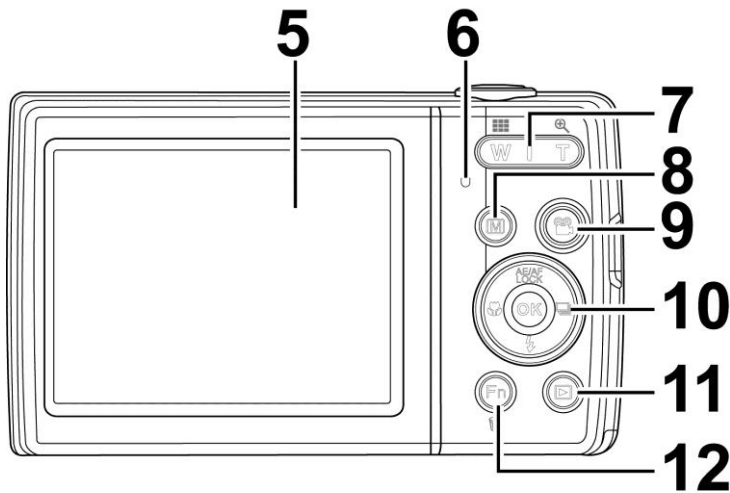

- 5. LCD monitor
- 6. LED indicator
- 7. Zoom button
- 8. Menu button
- 9. Movie button
- 10. OK button/4-way navigation control
- 11. Playback button
- 12. Fn/Delete button

Top View

- 13. Power button
- 14. Shutter button

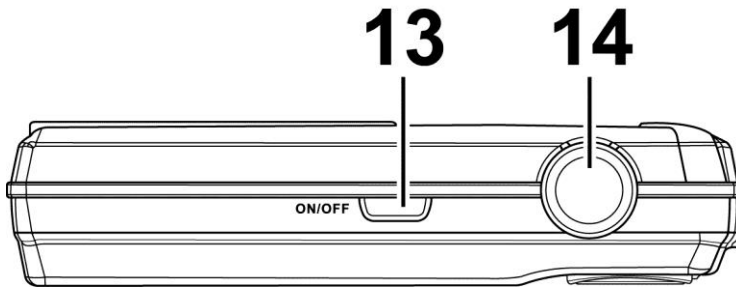

Bottom View

- 15. Battery/
Memory card
compartment
- 16. Speaker
- 17. Tripod screw
hole

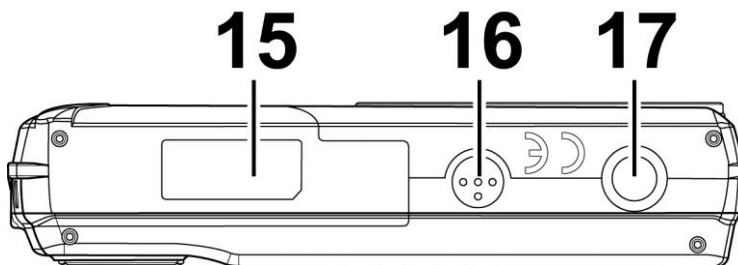

Left/Right View

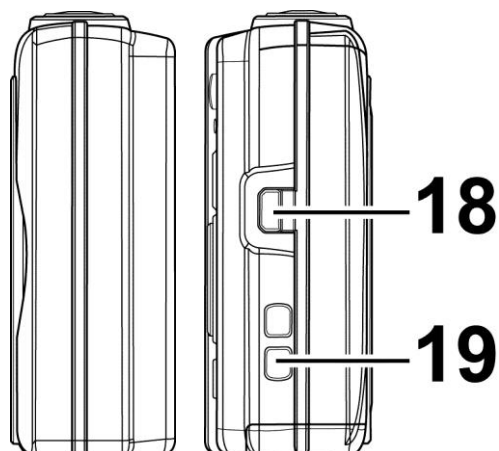

18. USB/TV Out

19. Strap ring

Camera Buttons

Your camera is equipped with different buttons for ease of use.

Power	Press the Power button to turn the power on/off.
Shutter	Press to capture an image.
Zoom button	In photo and movie mode, press the Zoom button (left/right) to zoom out/zoom in. In Playback mode, press button to zoom in to magnify image or zoom out enter 9-image/calendar thumbnails.
Menu	Press to enter or exit menu/submenu.
Fn/Delete	In Photo mode, press to enter function menu. In Playback mode, press to delete an image or video clip.
Playback	Press to enable Playback mode or return Record mode.
Movie	Press to start/stop recording video.

Navigation Control

The **4-way Navigation Control** and the **OK** button allow you to access the various menus available from the On Screen Display (OSD). You can configure a wide range of settings to ensure maximum results from your images and videos. Further functions of these buttons are as follows:

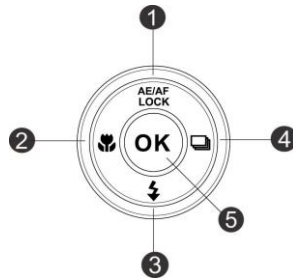

No.	Description
1	AE/AF LOCK
2	Macro Button
3	Flash Button
4	Continuous Shooting Button
5	OK Button

AE/AF LOCK/Up	<ol style="list-style-type: none"> 1. To lock AE/AF, press the AE/AF LOCK/Up button in Program Mode or half press the shutter button and then press the AE/AF LOCK/Up button. 2. To unlock AE/AF by any one of the following ways: <ul style="list-style-type: none"> • Press the AE/AF LOCK/Up button • Press the Zoom button • Press the MENU/Fn/Playback/Movie/Power button to launch another function • Switch to Super Macro/Manual Focus (For unlocking AE only) 3. In Menu, press to navigate through the menu and submenu selections.
---------------	---

Macro/Left	<ol style="list-style-type: none"> 1. In Photo Mode, press to scroll through Macro options. (Auto Focus, Super Macro, Pan Focus, Infinity and Manual Focus) 2. In Playback mode, press to view the previous image, video or audio clip. 3. In Playback movie mode, press to rewind video playback. 4. In Menu, press to exit a submenu or to navigate through the menu selections.
Flash/Down	<ol style="list-style-type: none"> 1. In Photo Mode, press to scroll through the flash mode options. (Auto, Red-eye Reduction, Forced On, Slow Sync and Forced Off) 2. In Menu, press to navigate through the menu and submenu selections.
Continuous Shooting/Right	<ol style="list-style-type: none"> 1. Press to scroll through Continuous Shooting options. (Single shot, Burst, Speedy Burst and GIF Capture) 2. In Playback mode, press to view the next image or video. 3. In playback Movie mode, press to forward video playback. 4. In Menu, press to enter the submenu or to navigate through the menu selections.
OK	<ol style="list-style-type: none"> 1. Confirm a selection when using the OSD menus. 2. In Playback Movie/Audio mode, press to start video or audio playback.

Getting Started

Inserting the Battery

Follow these instructions to insert the rechargeable battery into the battery/memory card compartment.

Please read "Battery Information" on page 5 before inserting/removing batteries.

1. Make sure the power is off before inserting the battery.

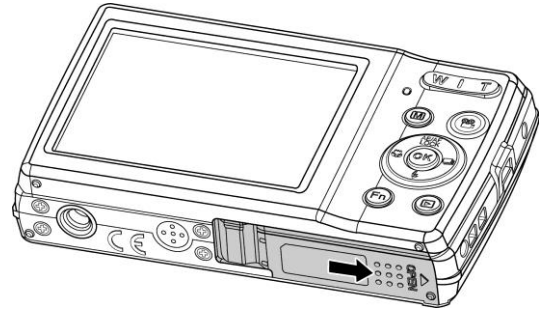

2. Unlock and open the battery/memory card compartment at the bottom of the camera.

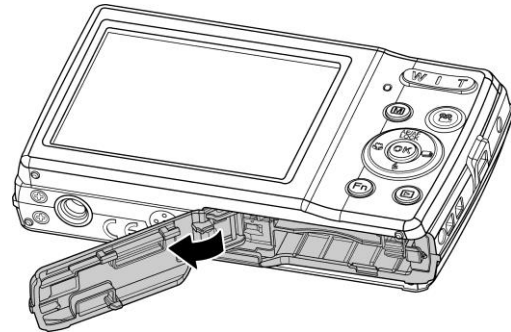

3. Insert the batteries into the compartment with the terminal facing inside the camera with correct orientation as shown.

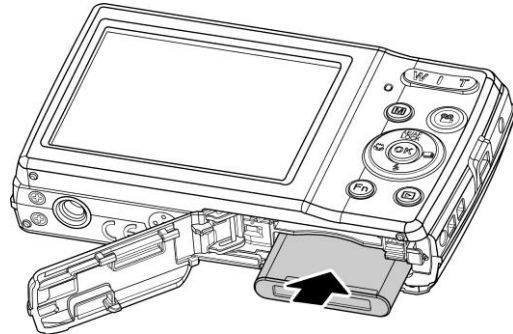

4. Close and lock the battery/memory card compartment. In order to prevent the battery from dropping, please make sure the compartment is locked firmly.

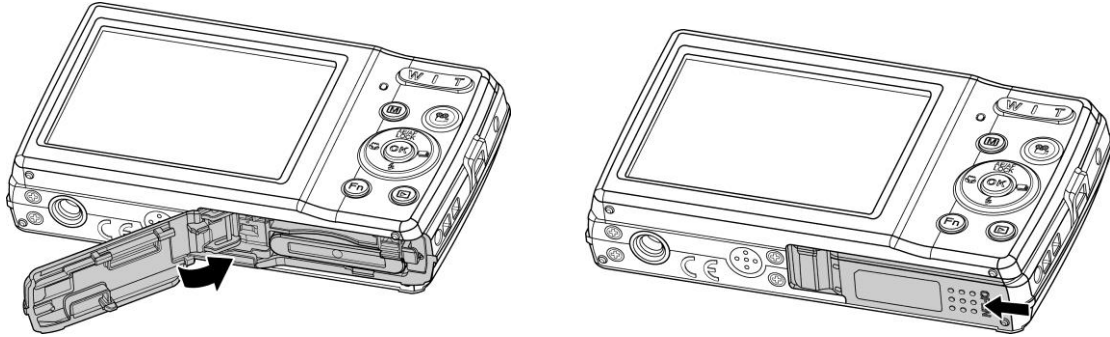

Camera Memory

Internal memory

Your camera is equipped with 64 MB of internal memory. Users can store files up to approximately 25 MB. If there is no memory card inserted in the memory card slot, all images and videos recorded are automatically stored in the internal memory.

External storage

Your camera supports SD cards of up to 4 GB in size. It also supports SDHC cards with a maximum capacity of 32 GB. Then also supports SDXC cards with a maximum capacity of 64 GB. If there is a storage card inserted in the memory slot, the camera automatically saves all images and videos in the external storage card. The icon  indicates the camera is using the SD card.



Not all cards will be compatible with your camera. When purchasing a card, please check the card's specifications and take the camera with you.

Inserting an SD/SDHC/SDXC Memory Card

Expand your camera's storage by using SD, SDHC or SDXC memory cards.

1. Unlock and open the Battery/memory card compartment at the bottom of the camera.
2. Insert the SD/SDHC/SDXC card into the memory card slot with the metallic part facing the back side of the camera.
3. Push the SD/SDHC/SDXC card into the memory slot until it clicks into place.
4. Close and lock the Battery/memory card compartment.

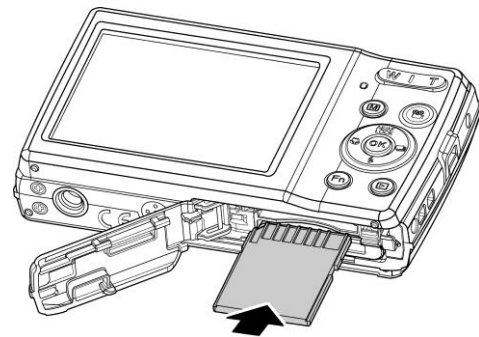
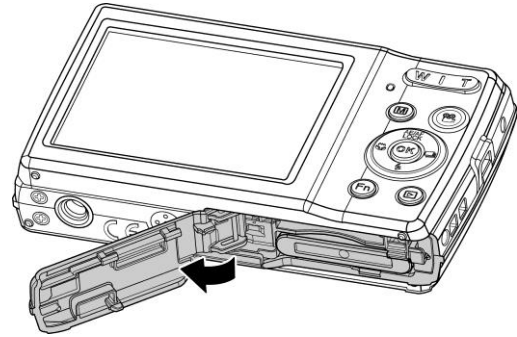

To remove the SD/SDHC/SDXC card

5. Unlock and open the battery/memory card compartment.
6. Gently push the card until it pops out.
7. Pull out the card carefully.

- Windows 2000/XP does not support SDXC card (exFAT format). But in Windows XP (Service Pack 2 or 3), you can download exFAT patch update to support SDXC card.
- To use the SDXC card with Mac OS, the OS version should be 10.5 or higher.
- The memory card that is not inserted correctly may cause damage to the camera. Please be careful when inserting the memory card.
- To prevent children from swallowing the memory card, please keep the memory card out of reach of children.



Charging the Battery by USB

You can also charge the battery by connecting the USB cable to your camera and PC.

1. Connect the camera with the USB cable as shown.
2. Connect the other end with the USB adapter and plug it into a power outlet or into the PC's USB port.

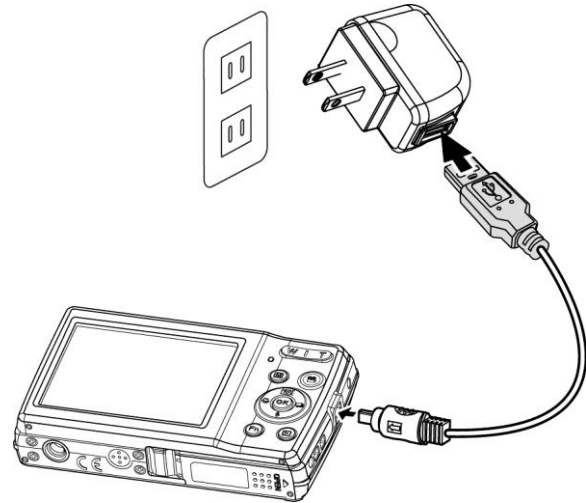

- When the battery is charging, the LED indicator flashes.
 - When the battery is fully charged, the LED indicator goes off.
 - When the battery is unusually charged, the LED indicator flashes rapidly.
 - When the camera charges without the battery inside, the LED indicator goes off.
- It's recommended to not operate the camera when charging. Charging time depends on current battery capacity and charging conditions.
- 
- You can also charge the battery with an Apple adapter. Its power output meets the standard 5V/500mA.
 - If the battery is removed during charging, it will only recover after you unplug or replug the USB cable.

Turning the Power On and Off

There are two ways to turn on the camera:

- The startup image displays briefly and the startup sound plays if enabled. The zoom lens extends and the camera is turned on in Record mode.
- The camera is turned on in Playback mode. The zoom lens is not extended.

To turn off the camera, press the **Power button**.

See "Modes" on page 21 to know more about Record and Playback mode.

Initial Settings

When you turn on your camera for the first time, you will be asked to do the initial settings of your camera. First is the setup of the language menu. Specify which language you would like the menus and messages to be displayed in on the LCD monitor.

Setting the Language

1. Press ▲, ▼, ◀ or ▶ to move through the selection.
2. Select a language, and then press **OK** to apply.

Setting the Date & Time

1. Press ◀ or ▶ to move through the selection.
2. Press ▲ or ▼ keys to change the value for the date and time.
3. Press **OK** to apply.
4. If necessary, press  to Cancel and return to language.

Now, you are ready to start taking images and videos.



Holding down ▲ or ▼ keys to change the values continuously.

Modes

Your camera has three modes:

Record Mode

Default mode when you turn on your camera. You are able to take images in this mode.

Playback mode

Press the **Playback button**  after the camera is turned on to view and edit captured images or playback videos. The recording of voice memos attached to images is available in this mode.

Movie mode

Press the **Movie button**  after the camera is *turned on* to start/stop recording video in this mode.

Using the LCD monitor

The LCD monitor shows all important information regarding camera settings as well as the visual image of your image or video. The display on the LCD monitor is called the On Screen Display or OSD.

LCD Monitor Layout

Photo Mode Screen Layout

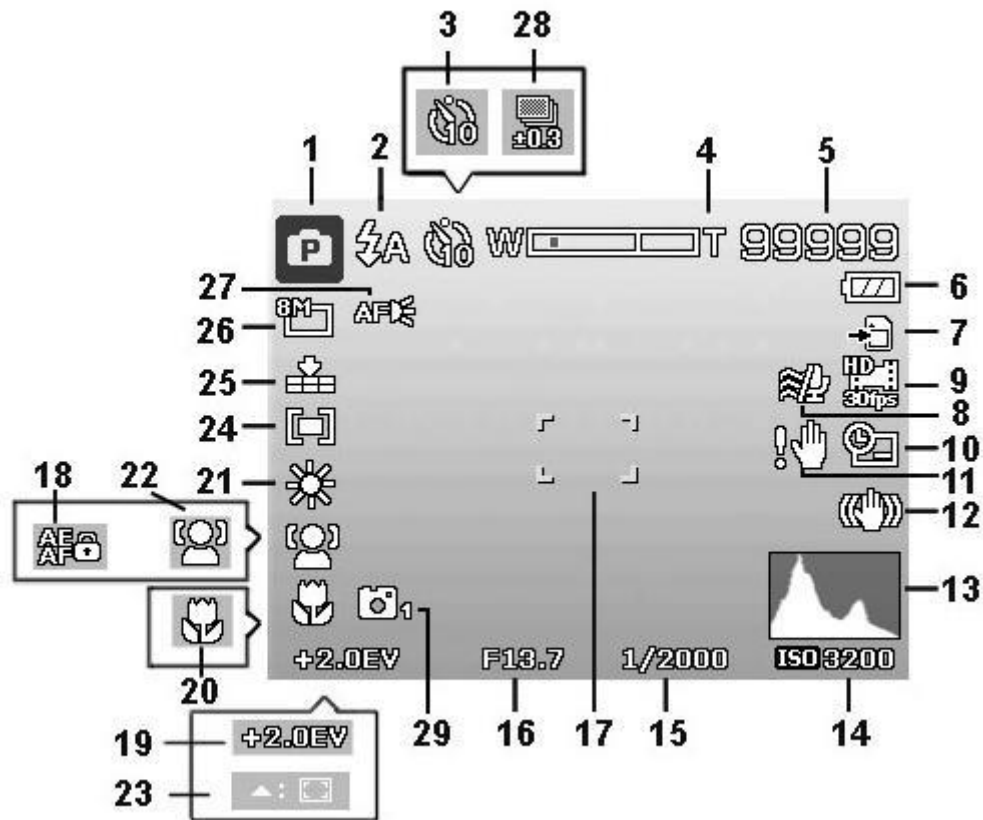

1	Record Mode	Indicates the current mode.
2	Flash	Indicates flash settings.
3	Self-timer	Indicates self-timer settings.
4	Zoom indicator	Displays zoom.
5	Shots remaining	Indicates the remaining shots available.
6	Battery	Indicates battery level.
7	Storage media	Indicates current storage media in use.
8	Wind Cut	Reduces wind noise during movie recording.
9	Movie size	Indicates movie size.
10	Date stamp	Indicates date stamp is enabled.

11	Shake warning	Indicates the light is not enough and the camera is shaking, which may cause the captured image to blur. If the shake warning appears, you can still capture images. However, enable Stabilizer, flashlight or use <i>of a</i> tripod is recommended to stabilize the camera.
12	Stabilizer	Indicates stabilizer function is enabled.
13	Histogram	Graphic display of Brightness.
14	ISO	Displays ISO settings.
15	Shutter speed	Displays shutter speed settings.
16	Aperture value	Displays aperture settings.
17	Focus area	Indicates focus area.
18	AE/AF Lock	Indicates AE/AF Lock is enabled.
19	EV Compensation	Displays exposure compensation settings.
20	Focus mode	Indicates focus is enabled.
21	White balance	Displays white balance settings.
22	Face tracking	Indicates face tracking is enabled.
23	Tracking AF	Indicates tracking AF is enabled.
24	Metering	Displays metering settings.
25	Quality	Displays quality settings.
26	Photo size	Displays photo size settings.
27	AF lamp	Indicates AF lamp is enabled.
28	Exposure bracketing	Displays Exposure bracketing settings.
29	Stylish	Indicates Stylish function is enabled.

Movie Mode Screen Layout



Recording Layout

1	PIV available	Indicates that you can capture a screenshot without stopping movie recording.
2	Recording status	Indicates recording status.
3	Recorded time	Displays recorded time.
4	Key indicator	Displays the commands on 4-way Navigation Control button.

Playback Mode Screen Layout

The Playback mode display varies depending on the type of image being viewed.

Playback mode display of still images:

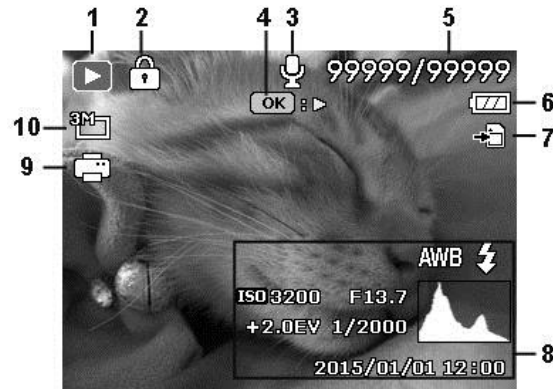

1	Playback mode	Indicates playback mode.
2	Protect	Indicates file is protected.
3	Voice memo	Indicates voice memo is attached.
4	Button intro	Indicates the button to press on the camera to play a video file.
5	File no./Total no.	Indicates the file number over the total number of files in the storage card.
6	Battery	Indicates battery level.
7	Storage media	Indicates used storage memory.
8	Recording information	Displays recording information of the file.
9	DPOF	Indicates the file is marked for printing.
10	Image Size	Displays the image size settings.

Playback mode of videos:

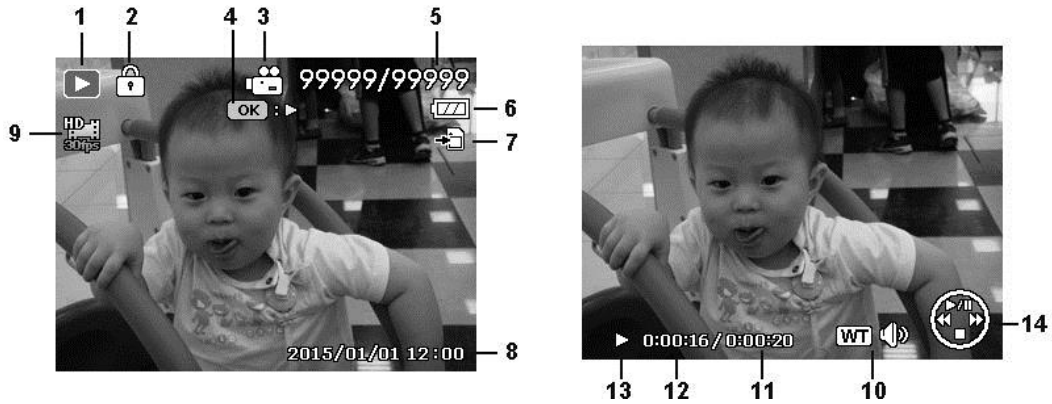

1	Playback mode	Indicates playback mode.
2	Protect	Indicates file is protected.
3	Video clip	Indicates the file is a video.
4	Button indicator	Displays the button info of Playback mode.
5	File no./Total no.	Indicates the file number over the total number of files in the storage card.
6	Battery	Indicates battery level.
7	Storage media	Indicates used storage memory.
8	Recording date & time	Displays the date and time of the video clip.
9	Video size	Indicates the size of the video clip.
10	Button intro	Indicates the button to press on the camera to adjust the volume.
11	Video length	Display the total length of the video clip.
12	Video time	Indicates the video time.
13	Playing status	Displays playing status.
14	Button intro	Indicates the button to press on the camera to play a video file.

Recording Images and Videos

Taking Images

Now that you are familiar with your camera, you are ready to take your images. Taking images with your camera is very simple.

1. Turn on the camera by pressing the **Power button**.
2. Frame the shot using the focus bracket on the LCD monitor. See illustration on the right.
3. Pressing the **Shutter button** down halfway automatically focuses and adjusts the exposure, and pressing the **Shutter button** down fully captures the images.

When the shake warning icon  appears, hold the camera steady, use a tripod to stabilize the camera if needed.

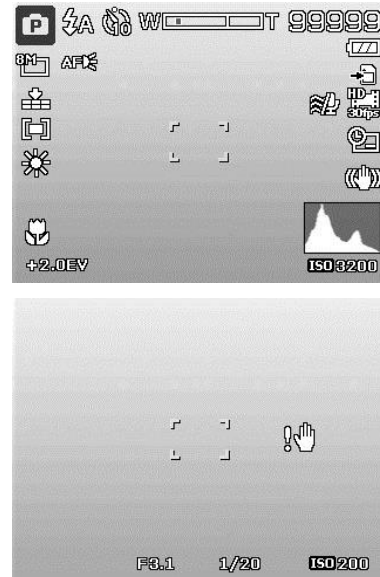



Setting the Zoom Control

Using a combination of 5 times optical zoom and 8 times digital zoom permits zoom photography up to 40 times magnification. While the digital zoom can be a useful feature, the more an image is enlarged (zoomed), the more pixelated (grainier) the image will appear. Please refer to "Setting the Digital Zoom" on page 56 on how to setup digital zoom.

To adjust the optical zoom:

1. Press the Zoom button to zoom in or zoom out of an image.
2. The zoom indicator appears on the LCD monitor. W  T

Zoom button

1. Press the Zoom button (right) to zoom in. 
2. Press the Zoom button (left) to zoom out. 



To adjust the digital zoom:

1. Activate digital zoom. See "Setting the Digital Zoom" on page 56.
2. Press the **Zoom button** (left/right) optically zooms in/out to the maximum until it stops.
3. Release the **Zoom button**.

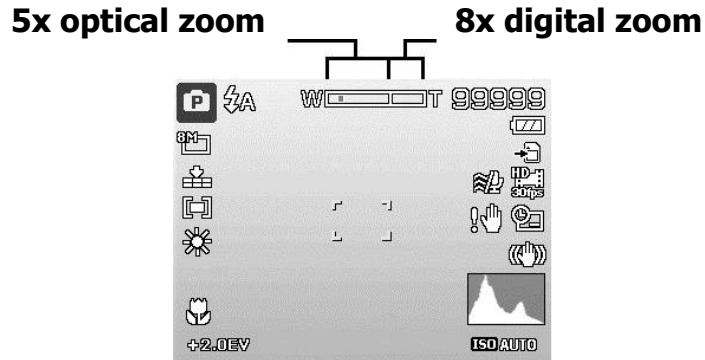

Using the AE/AF LOCK/UP Button

Use the AE/AF LOCK/UP button on your camera to lock focus and exposure.

1. To lock AE/AF, press the AE/AF LOCK/Up button in Program Mode or half press the shutter button and then press the AE/AF LOCK/Up button.
2. To unlock AE/AF by any one of the following ways:
 - Press the AE/AF LOCK/UP button
 - Press the Zoom button
 - Press the MENU/Fn/Playback/Movie/Power button to launch another function
 - Switch to Super Macro/Manual Focus (For unlocking AE only)

AE/AF LOCK/UP Button



Using Flash

When taking pictures in difficult lighting conditions, use the **Flash/Down** button to get correct exposure. This function cannot be activated when recording videos or continuous shooting.

To activate Flash:

- Press the **Flash/Down** button on your camera repeatedly until your desired flash mode is displayed on the LCD monitor.



**Flash/Down
button**

Your camera is equipped with five flash modes:

⚡A Auto Flash. The flash fires automatically whenever extra lighting is needed.

⚡👁 Red-eye reduction. The flash fires twice to reduce the red-eye effect.

⚡ Forced on. The flash fires whenever you press the Shutter button regardless of lighting conditions.

⚡SL Slow sync. The flash fires with a slow shutter speed.

⚡🚫 Forced off. The flash is turned off.



- Flash function is only available when shooting still images but not available in Burst and GIF modes.
- Do not press the flash while pressing the Zoom button. Press the flash after releasing the Zoom button if necessary.

Setting the Focus Mode

This function allows users to define the type of focus when recording a still image.



To set the Focus mode

- Press the **Focus/Left** button on your camera to launch the Focus function.
- To select focus options, press the ◀ or ▶ keys. Press the **OK** button to save and apply changes.



Your camera supports the 4 focus modes:

AF Auto Focus. With auto focus, the camera will focus on the subject automatically.

  **Macro/Super Macro.** This mode is designed for close-up photography. When Super Macro is set, the focus cannot be adjusted until Super Macro is cancelled.

 **Infinity.** When Infinity is set, the camera focuses on distant objects.

MF Manual Focus. With manual focus, you can adjust the focus distance from 5cm to infinity by press Up/Down button. Press OK button to lock the focus and exit the adjusting screen.





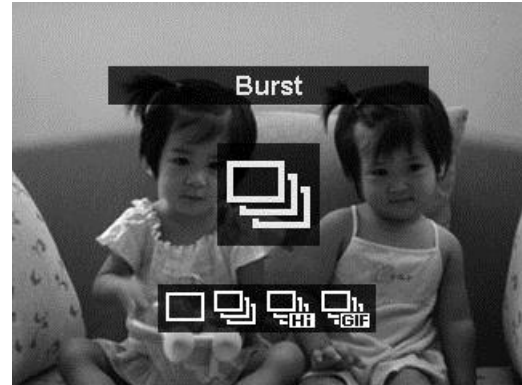

Setting Continuous Shooting

This function allows users to set the continuous shooting mode. It's only available in shooting still images. Press Right button to launch the Continuous Shooting menu options, and then press Left/Right button to select the desired option.



Continuous Shooting/Right button

	Single Shot	Disable the continuous shooting function.
	Burst	Fully press and hold the shutter button for continuous shooting. It will only stop when you release the shutter button or the memory card is full.
	Speedy Burst	Captures 30 images in a shot when the Shutter button is pressed. Auto set Image size to 4:3 VGA only.
	GIF Capture	Use this feature to take a specific number of images in a specific shooting interval. The taken images will be combined into a GIF file and will no longer exist individually.

Using the Function Menu/Delete Button

Function Menu

Press the **Fn/Delete** button in Record mode to bring up the Function Menu with the most common features for photos and movies.



Press the **Fn/Delete** button of your camera to launch the Function Menu.

Press the **Fn/Delete** button again to close the menu.

- The Menu bar displays the current status of your camera settings. Only the available functions for the settings are shown as icons on the menu bar.
- The available options for each item on the menu bar are shown in the Menu options.
- Use the ◀ or ▶ key to move through the menu selections then press the **OK** button to save and apply changes.
- Press **Menu** button or **Fn/Delete** button to cancel selection and close Function Menu.

Menu bar







Menu Options





Photo Size

The Photo Size function is used to set the resolution before you capture the image. Changing the Photo Size affects the number of images that can be stored in your memory card. The higher the resolution, the more memory space is required.



The table below shows the Photo Size values for still images.

	5152 x 3864	A2 Size
	3264 x 2448	A3 Size
	2592 x 1944	A4 Size
	2048 x 1536	4" x 6"
	640 x 480	E-mail

	5152 x 3435	Standard print paper
	5152 x 2898	HDTV
	1920 x 1080	HDTV
	2992 x 2992	Square Composition

EV Compensation

Images can be captured with the overall scene intentionally made brighter or darker. These settings are used when a suitable brightness (exposure) cannot otherwise be obtained in circumstances where the difference in brightness between the subject and the background (the contrast) is large, or when the subject that you wish to capture is very small within the scene. Available for still images only.

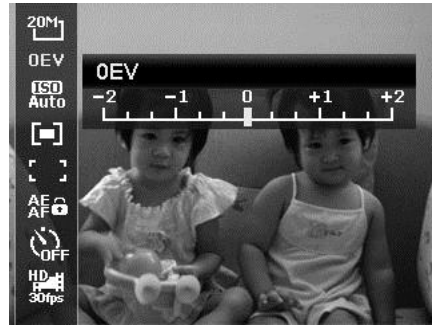

- To adjust EV settings, press the ◀ or ▶ keys to increase/decrease the value. As you adjust the settings, the LCD monitor synchronously displays the image applying the EV settings. Press the **OK** button to save and apply changes.



- The EV compensation is enabled only when using Program mode.
- The EV menu is hidden if the Tracking AF has been turned on.

ISO

This sets the sensitivity for capturing images. When the sensitivity is raised (and the ISO figure is increased), photography will become possible even in dark locations, but the image will appear more pixelated (grainier).

- Use a higher ISO setting in dim conditions and a lower ISO setting in brighter conditions.



Metering

This sets the metering method for calculating the exposure.



	Multi	The entire area of the screen is measured, and the exposure is calculated.
	Center	Averages the light metered from the entire frame, but gives greater weight to the subject matter at the center.
	Spot	A very small portion of the center of the screen is measured, and the exposure is calculated.

AF Area

AF stands for Automatic Focus. This feature determines the area on which the camera focuses.

To set AF Area

1. From the Record menu, select **AF Area**.
2. Use the ▲ or ▼ keys to go through the selection.
3. Press the **OK** button to save and apply changes.



The table below shows the available AF area settings.

	Face Tracking	This feature auto detects faces and tracks continuously.
	Wide	The camera automatically selects focus area within the wide frame.
	Center	The focus area is fixed on the center.

	Tracking AF	The camera will focus the subject as it moves and keep it continually in focus automatically.
---	-------------	---

AE-L/AF-L

This feature allows locking exposure or focus or both of them by pressing AE/AF LOCK/UP button. You can define the AE/AF LOCK/UP button to be one of the following functions:

- AE-L: Lock/Unlock exposure.
- AF-L: Lock/Unlock focus.
- AE-L & AF-L: Lock/Unlock both exposure and focus.



Press the AE/AF LOCK/UP button to unlock it.

Self-timer



Your camera features a Self-timer which can be set in the Self-timer function in the Function Menu. The Self-timer allows you to take images after a pre-defined delay, while burst lets you take consecutive shots. This function is only available when recording still images. The Self-timer setting is automatically set to off when you turn off the camera.





To set the Self-timer

1. From the Function menu, select **Self-timer**.
2. Use the ▲ or ▼ keys to go through the selection.
3. Press the **OK** button to save and apply changes.

The table below shows the available Self-timer settings.

	Off	Captures an image without time delay.
	10 Sec.	Sets a 10-second delay to capture image after pressing the Shutter button.

	2 Sec.	Sets a 2-second delay to capture image after pressing the Shutter button.
	Double	Performs delay and captures twice: <ul style="list-style-type: none"> • Performs a 10-second delay, then captures the image. • Performs another 2-second delay then captures the image again.

Using the Movie Menu

You can access the Movie menu simply by pressing the **MENU button** on your camera.

When the menu is displayed, use the 4-way navigation control and the **OK button** to move through menu selections and apply your desired settings. To close the menu anytime, press the menu button again.

Setting Movie Mode

Use this function to adjust the resolution and quality of movie clips.

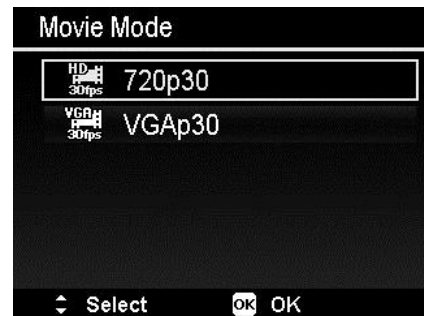

- The options FHD and HD are only available when a SDHC class 4 or class 6 card is inserted.
- Due to limits from the FAT format, VGA recording requires approximately 2 hours.

Setting Prerecord

You can catch the first three seconds of action you would have potentially missed. Once this function is enabled, the camera starts recording video automatically before pressing Movie button. As soon as the Movie button is hit, the most recent three seconds of video is added to the beginning of the clip.

The icon is displayed in red when Prerecord is on.

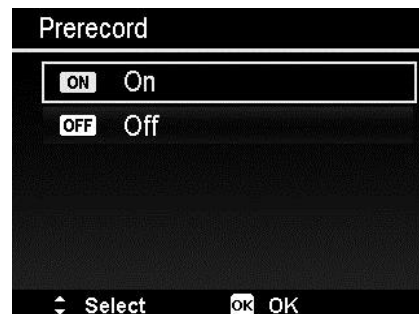



Prerecord will be canceled in the following situation:

- After recording starts.
- Switch to Playback mode.
- Launch the Menu.
- Enter USB mode.
- Power off the camera.



Prerecord function will be disabled in the following situations:

- The prerecord time is less than 2 seconds.
- There is not enough internal memory to enable this function unless an additional memory card is inserted to the camera.

Wind Cut Setting

This feature reduces wind noise during movie recording.



Continuous AF

This function allows you to record video with auto focus method.

1. Enable the Continuous AF under the Movie Menu.
2. Use the ▲ or ▼ keys to go through the selection.
3. Press the OK button to save and apply changes.

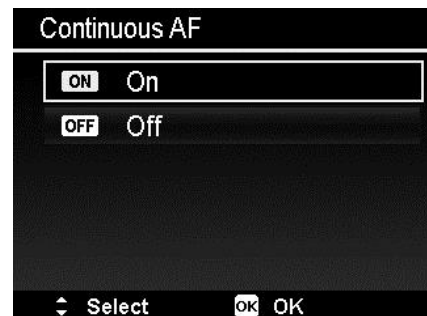

Delete Button

The Delete function allows you to remove unwanted files in the internal memory or on the memory card. Protected files cannot be erased, to delete, unprotect the file first. See "Protect" on page 65.

To delete an image/video clip:

1. Press the **Playback button**  on the camera.
2. View images/videos clips in Single navigation mode.
3. Use the ◀ or ▶ keys to scroll the display.
4. When the desired image/video clip is displayed on the LCD monitor, press the **Delete** button.
5. A confirmation selection appears on screen.
6. To close the Delete function and go back to the single navigation mode, press **Menu** button.

To delete a single file:

1. After a confirmation selection appears on screen. Select **Single**.
2. Press the **OK** button and select **Yes** to delete.
3. The next image is displayed on the LCD monitor. To delete another file, use the ◀ or ▶ keys to scroll through the images/videos clip. Repeat steps 1 to 2.
4. To close the Delete function and go back to the single navigation mode, press **Menu** button.



To delete attached voice memo:

1. After a confirmation selection appears on screen. Select **Single**.
2. A delete voice memo option will be added to the selection.
3. Select and press **OK** to delete voice memo only and back to single navigation.
4. Or select **Yes** to delete both image and its voice memo.



To delete multiple files:

1. After a confirmation selection appears on screen. Select **Multi**.
2. The images are displayed in thumbnail view on the LCD monitor.
3. Use the ◀ or ▶ keys to move through the files.
4. When the desired image/video clip is highlighted, use the ▲ or ▼ keys to mark/unmark image/video clip for deletion.
5. Repeat step 4 until all desired images which you would like to delete are marked.
6. Press the **OK** button. A confirmation selection appears.
7. Select **Yes** to confirm.
8. Press the **OK** button to delete marked files.

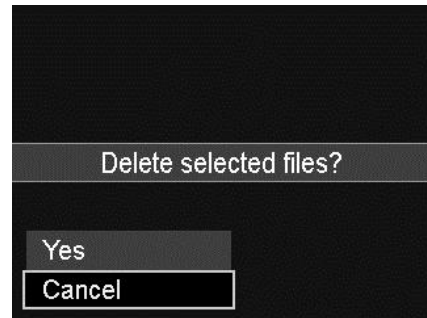
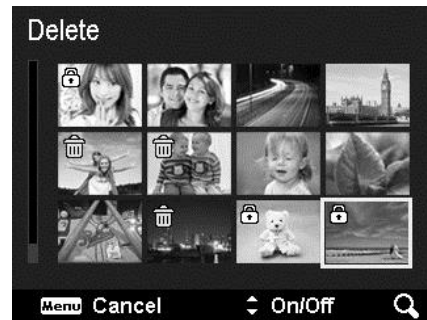

To delete all files:

1. After a confirmation selection appears on screen. Select **All**.
2. Select **Yes**.
3. Press the **OK** button to delete all files.

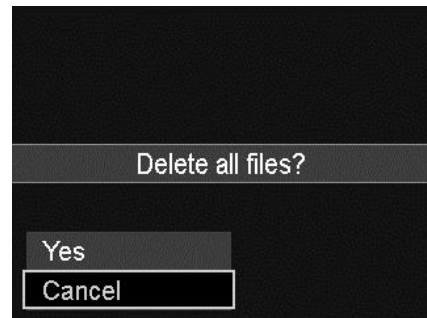

Recording Videos

You can record videos with this camera, the available recording time depends on the capacity of the memory card. Videos can be recorded until the maximum memory capacity has been reached. However the length of a single video may be limited (the limitation depends on the camera model).



1. Press the **Movie button** to start recording. 
2. Focus your camera on the subject that you want to take.
3. Use the **Zoom button** to zoom in and zoom out an image.
4. To stop recording, press the **Movie button**.



- The camera will automatically stop recording when the memory capacity is full.
- It will automatically stop recording when the recording time is over 29 minutes or the file size is over 4 GB.
- When the temperature of CCD Sensor is over 63°C, the camera will display the warning message.
- When the temperature of CCD Sensor is over 65°C, the camera will shutdown automatically.

PIV function

During the movie recording, press shutter button, an icon  displayed on LCD means that the current screen can be stored as a photo without stopping movie recording by pressing the shutter button. The PIV feature is only applicable to movie size: 720p30 and VGAp30.



- When the movie size is 720p (30fps), the captured photos are saved at 1280 x 720 resolution.
- When the movie size is VGA (30fps), the captured photos are saved at 640 x 480 resolution.

Settings of Recording Videos

See "Using the Movie Menu" on page 37 for more details.







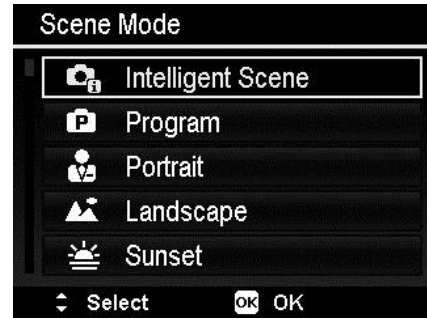



Setting the Scene Mode











By simply selecting one of the following 23 modes, you can capture the image with the most appropriate settings.

1. From the Record Menu, press to select **Scene Mode**.
2. Use the navigation controls to move through the selection.
3. Press the **OK** button to save and activate the selected scene mode.



The table below shows the available scene mode settings.

	Intelligent Scene	The camera detects the shooting conditions and automatically switches to the appropriate scene mode. See "Using Intelligent Scene" on page 44 for more details.
	Program	The camera automatically adjusts suitable shooting settings like shutter speed and aperture values.
	Portrait	The camera blurs the background to focus on the subject.
	Landscape	This feature is used to emphasize wide scenic views.
	Sunset	This feature enhances the red hue for recording sunset images.
	Backlight	This feature is used to capture the image of a backlight object by changing the metering.
	Kids	This feature is used to capture still images of moving kids.
	Night Scene	This feature is used to capture images with night scenery background.
	Fireworks	This feature slows shutter speed to capture fireworks explosions.
	Snow	This feature is used for beach and snow scenes.
	Sports	This feature captures still images in high speed motions.

	Party	This feature is used for wedding or indoor party settings.
	Candlelight	This feature is used to capture warm candle light effects.
	Night Portrait	This feature is used to capture portrait pictures with night or dark backgrounds.
	Soft Skin	This feature enhances skin tone thus facial skin appears smooth.
	Flowing Water	This feature enhances smooth effects like water or silk.
	Food	This feature is used to capture food images. The increased saturation in this mode makes the captured image more enticing.
	Love Portrait	This feature uses face tracking to auto detect faces to capture portraits images without the help of others. When over two faces are detected, AF is automatically activated. The camera starts count down and captures a picture in two seconds.
	Self Portrait	This feature sets zoom to wide. When one face is detected, AF automatically activated and plays the sound (Bi) for notice. Then camera starts count down and captures a picture in two seconds.
	D-Lighting	This feature applies digital processing only to the necessary portion(s) of the image and preserves details in highlights and shadows with natural contrast.
	Time Lapse	Use this feature to take photos automatically at the specified intervals. See "Using Time Lapse" on page 46 for more details.
	Panorama	Use this feature to create a panoramic photo by panning or tilting the camera.
ART	Art Effect	This feature applies different art effect on the still images.

Using Intelligent Scene

This feature is most useful for novice users to capture great images even without basic knowledge of photography. Simply frame the shot with the help of Intelligent Scene Mode, the camera automatically recognizes 7 kinds of scenes - Portrait, Landscape, Macro, Backlight, Backlight Portrait, Night Scene and Night Portrait - and selects the ideal settings.

Intelligent scene icon. After the camera detects the shooting conditions, this icon changes to show the detected scene mode.



The camera changed to Landscape mode automatically.

To activate Intelligent Scene

1. Select **Intelligent Scene**  in **Scene Mode** menu.
2. Focus the camera on the subject to capture.
3. The camera detects the shooting conditions and switches to an appropriate scene mode.
4. Half press the Shutter button to focus the subject. The frame turns green to indicate focus is set.
5. Press the Shutter button to take the shot.



Using Kids Mode

Tactically, kids are the most difficult to photograph. They tend to be highly animated and can be a real challenge to make them pay attention for more than just a second or two. To capture a great moment for your kids, just keep the camera in kid mode. The mode provides higher shutter speed and always focuses on moving subject.

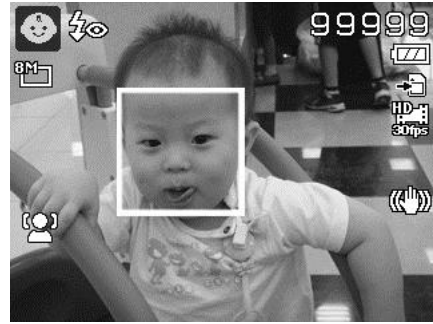

Using Sports Mode

When you need a series of sports motion images, such as a golf swing, or try to capture the images of a flying hummingbird/butterfly, be sure to switch the scene mode to sports mode.

Using Party Mode

Leave Party mode on! It can be difficult to get a photograph of everyone at a party. While you have the whole gang together, take a group or family portrait. Party mode features Red-eye reduction flash and face tracking. You'll miss fewer shots, and have more time to focus on enjoying the party.

Using Food Mode

Share your dining experiences online with Food mode. This mode features on macro focus and auto flash designed for close-up photography.

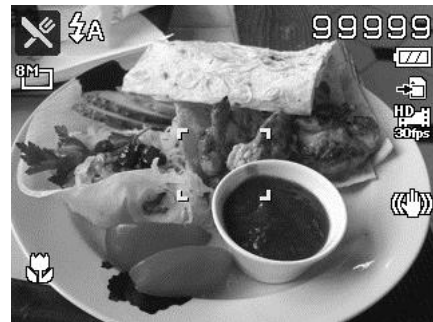

Macro focus and Auto Flash are enabled by using Food mode.

Using Love Portrait

Want to take a good image when there are just two of you? All you have to do is hold the camera and smile.

If two faces have been recognized, the camera performs a 2-second countdown and then takes a photograph without you having to press the **Shutter button**.

Using Self Portrait

When you are taking a photograph of yourself select self portrait mode. First the camera begins face tracking. If a face had been recognized, the camera performs a 2-second countdown and then takes a photograph without you having to press the **Shutter button**.

Using Time Lapse

Use this feature to take photos automatically at the specified intervals. The photo size will be 16:9 (2M). In Time Lapse mode, press **Right** button to launch the Time Lapse menu, and then press **Up/Down** button to select the options.



Available options are 30 sec. (Default), 1 min., 5 min., 10 min., 30 min., 60 min. Press **OK** button to apply the setting and close the menu.

You can fully press the Shutter button to start and stop recording. The Time Lapse photos will be merged into a Time Lapse movie at 10 fps.

And

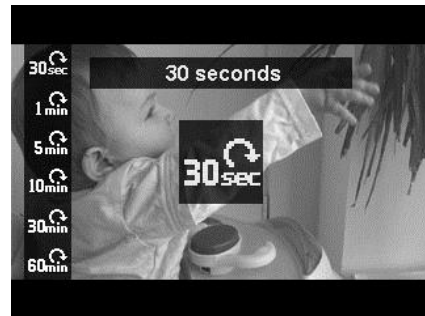

Photos taken from Time Lapse will be combined into a movie and will **NOT** exist individually in photo.

Using Panorama Mode

Use this feature to create a panoramic photo from multiple shots. You can combine several shots into one single image quickly and easily.



- The actual size of the image may differ from time to time.
- It is recommended to use a tripod to stabilize the camera, and then move the camera slowly during capturing.
- A time limit of 30 seconds is given to capture the photograph.
- If you select **From Top to Bottom** or **From Bottom to Top** in **360-degree** panorama, it is recommended to turn the camera over 90 degrees in order to make sure the camera is stable.
- In Panorama mode, uneven brightness may result in the photograph looking slightly different than what you expected.

To stitch the still image

1. Press **▼** key to launch the **Angle Menu**. Use the **▲** or **▼** keys to select options. Press the **OK** button to save and apply changes.
2. Press **▶** key to launch the **Direction Menu**. Use the **◀** or **▶** keys to select options. Press the **OK** button to save and apply changes.



3. Fully **press** the shutter button to start shooting. When shooting starts, a white-cross appears in the center and a yellow line displays horizontally (or vertically) through the screen. In
4. If **you** move the camera without keeping it straight, the yellow line will move with the moving scene.

addition, a shooting bar is displayed to show the shooting position and the white bar indicates which part of the scene has been taken.

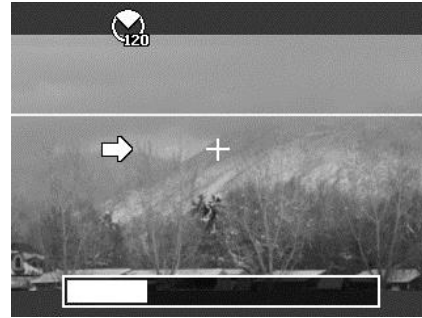
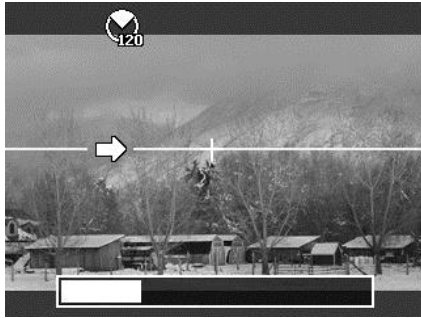

5. When the white bar reaches the end the camera will finish automatically and save the panorama image.

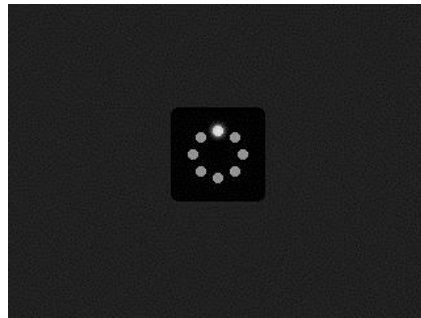





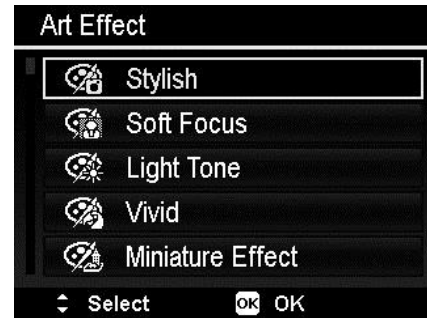











Using Art Effect

Effect that cannot be presented on Preview.
Does not apply to movie recording and continuous shooting.



Press ▲ or ▼ keys to select between the following settings:

	Stylish	This feature is used to capture images with over-saturated colours, off-kilter exposure or blurring.
	Soft Focus	Produces halo around the photographed object to achieve the effect of soft focus.
	Light Tone	Reduces contrast to create a smooth and relaxed atmosphere.
	Vivid	The camera captures the image with more contrast and saturation emphasizing on the bold colours.
	Miniature Effect	Blur parts of the photo to make the scene look like a miniature scale model. It is recommended to capture from a high angle to simulate the miniature effect.
	Fisheye Lens	This feature captures images with fisheye lens effects.
	Astral	Image is applied with starburst.
	Poster	This feature captures images with old poster or illustration effects.
	Impressive Art	This feature captures images with dramatic contrast.

	B&W	Images are captured in black and white.
	Sepia	Images are captured in sepia tones.
	Color Accent (Red)	Retains red tone while the rest of the scene becomes black and white.
	Color Accent (Orange)	Retains orange tone while the rest of the scene becomes black and white.
	Color Accent (Yellow)	Retains yellow tone while the rest of the scene becomes black and white.
	Color Accent (Green)	Retains green tone while the rest of the scene becomes black and white.
	Color Accent (Blue)	Retains blue tone while the rest of the scene becomes black and white.
	Color Accent (Purple)	Retains purple tone while the rest of the scene becomes black and white.

Using the Record Menu

If you are in Photo Mode, you can access the Record menu simply by pressing the **MENU button** on your camera.

When the menu is displayed, use the 4-way navigation control and the **OK** button to move through menu selections and apply your desired settings. To close the menu anytime, press the menu button again.

Record Menu

The Record menu allows you to change modes, and setup other capture settings.

To go to Record Menu:

Turn on the camera by pressing **Power button**.

Press  to launch the Record Menu.

Use the ▲ or ▼ keys to move through the menu





To select an item, press ► or **OK** button.





Change the submenu settings using the 4-way navigation control.

Press the **OK** button to save and apply settings.



The table below shows the Photo Size values for still images.



	5152 x 3864	A2 Size
	3264 x 2448	A3 Size
	2592 x 1944	A4 Size
	2048 x 1536	4" x 6"
	640 x 480	E-mail

	5152 x 3435	Standard print paper
	5152 x 2898	HDTV
	1920 x 1080	HDTV
	2992 x 2992	Square Composition

Quality

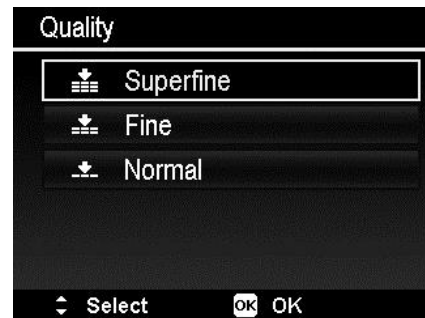
The Quality sets the quality (compression) at which the image is captured. The quality determines the amount of compression applied to your images. Fine quality would give you the best images with sharper details and less compression. However, the higher the quality, the more memory space is required in your memory card.









	Superfine	5x compression rate.
	Fine	8x compression rate.
	Normal	12x compression rate.

White Balance

This sets the white balance for a variety of lighting conditions.

- As you move through the selection, you can see the preview on the LCD monitor synchronously.
- Press ► to enter **WB Shift**. This feature allows you to correct the white balance of **AWB** option.



	Auto White Balance	The camera automatically adjusts the white balance.
	Daylight	Ideally used for bright sunny conditions.
	Cloudy	Ideally used for cloudy conditions.
	Tungsten	Ideally used for indoor images with tungsten or halogen lighting without a flash.
	Fluorescent 1	Ideally used for indoor images with bluish fluorescent lighting conditions.
	Fluorescent 2	Ideally used for indoor images with reddish fluorescent lighting conditions.
	Custom	Used when light source cannot be specified. Press ► for the camera to automatically adjust the appropriate white balance setting according to the environment.

ISO

This sets the sensitivity for capturing images. When the sensitivity is raised (and the ISO figure is increased), photography will become possible even in dark locations, but the more pixelated (grainier) the image will appear.

- Use a higher ISO setting in dim conditions and a lower ISO setting in brighter conditions.

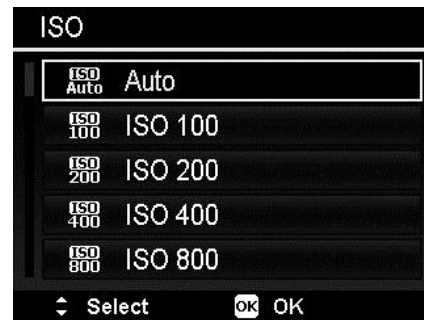

Maximum ISO Auto



This feature allows the camera to adjust the ISO Auto from ISO 100 to the value set in Maximum sensitivity, according to light conditions. Available options are 200, 400, 800 (Default).

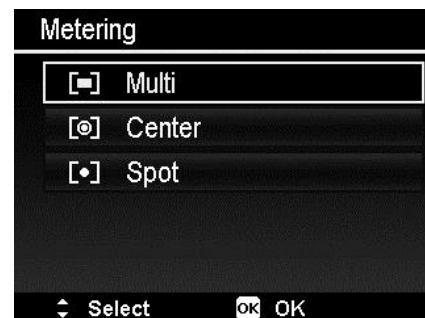

Metering

This sets the metering method for calculating exposure.



	Multi	The entire area of the screen is measured, and the exposure is calculated.
	Center	Averages the light metered from the entire frame, but gives greater weight to the subject matter at the center.
	Spot	A very small portion of the center of the screen is measured, and the exposure is calculated.

Setting the Exposure Bracketing

Use this feature to take photos with different exposure compensation. Bracketing records 3 continuous images in the following order: Standard exposure, Underexposure and Overexposure.

Available settings are: Off, ± 0.3 , ± 0.7 and ± 1.0 .

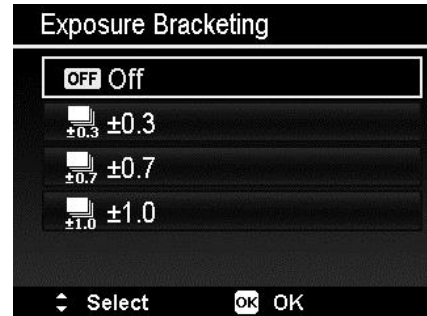

Setting the AE-L/AF-L

This feature allows locking exposure or focus or both by pressing the AE/AF LOCK button. You can define the AE/AF LOCK button to be one of the following functions:

- AE-L: Lock/Unlock exposure.
- AF-L: Lock/Unlock focus.
- AE-L & AF-L: Lock/Unlock exposure and focus.

Press the AE/AF LOCK button to unlock it.

To lock AE/AF, press the AE/AF LOCK button during movie recording or half press the shutter button then press the AE/AF LOCK button in Photo mode.



Show this function only when using Program mode.

Setting the Digital Zoom

This feature controls the digital zoom mode of your camera.



Your camera enlarges an image using the optical zoom first. When the zoom scale exceeds 5x, the camera uses digital zoom.

To set Digital Zoom

1. From the Record menu, select **Digital Zoom**.
2. Use the ▲ or ▼ keys to go through the selection.
3. Press the **OK** button to save and apply changes.

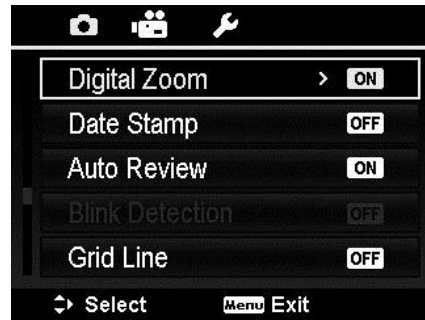
The table below shows the available Digital Zoom settings.



	On	Enlarges all image sizes, but the image quality deteriorates.
	Off	Uses the optical zoom only.



Digital Zoom is not available when Face Tracking is on.

Setting the Date Stamp

The date of recording can be printed directly on the still images. This function must be activated before the image is captured. Once date and time are stamped on an image, they can no longer be edited or deleted.

Limitations of Date Stamp functions are as follows:

- Available for still images only.
- This feature does not apply to continuous shooting mode.
- In vertical or rotated images, the date and time on your images still appear horizontally.

To set Date Stamp

1. From the Record menu, select **Date Stamp**.
2. Use the ▲ or ▼ keys to go through the selection.
3. Press the **OK** button to save and apply changes.

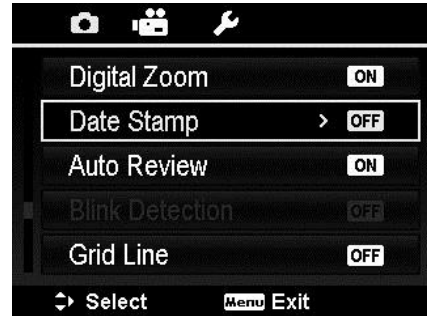

Setting Auto Review

The Auto Review function lets you view the captured image right after shooting it.

If Auto review is On, the camera will display the captured image for **1 second** on the LCD monitor.

To set Auto Review

1. From the Record menu, select **Auto Review**.
2. Use the ▲ or ▼ keys to go through the selection.
3. Press the **OK** button to save and apply changes.



Blink Detection

Nothing ruins a great picture more than having your subjects' eyes closed. Blink Detection provides you with extra assurance when capturing once-in-a-lifetime moments like holding a trophy with teammates after winning a basketball game.

If closed eyes are detected, a saving confirmation menu appears on the screen,

allowing you to re-take the shot before your subject or subjects move on.

To activate Blink Detection

1. Enable Blink Detection from Record menu.
2. Half press the **Shutter button** to focus the subject. The frame turns green to indicate focus is set.
3. Press the **Shutter button** to capture the image and automatically save the Image.
4. If the camera detects subject blinked eye, a "**Save image**" or "**Cancel**" option appears on the screen.
5. Select **Save image** to save or **Cancel** to disregard

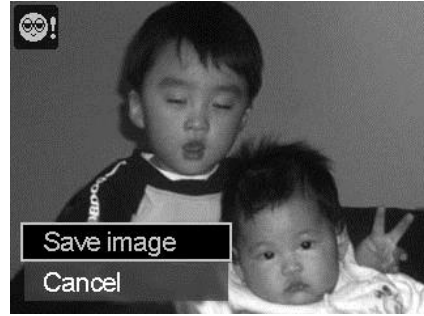

Blink Detection appears in Record menu only when Face Tracking is turned on

Setting Grid Line

The Grid Line function will show a framing grid on the preview of your photographs. Available settings are: **On**, **Off**.

The configuration of Grid Line will be changed with different aspect ratio.

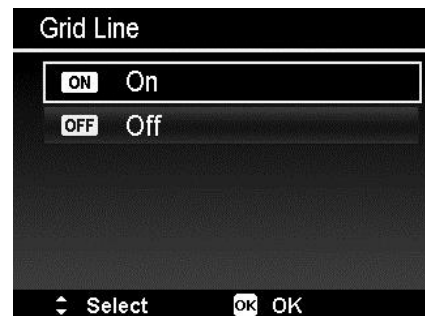

Setting Stabilizer

This function allows you to prevent blurred images caused by shaking.

1. Enable the Stabilizer under the Record Menu.
2. Use the ▲ or ▼ keys to go through the selection.
3. Press the OK button to save and apply changes.

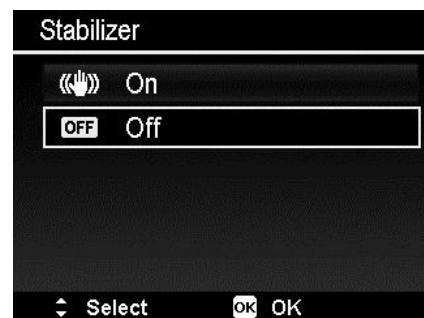

Playback

You can playback still images and video clips on the LCD monitor.

Viewing in Single Navigation

The Single navigation mode displays the image one by one on the LCD monitor. To view images/video clips, follow the steps below.

1. Press the **Playback button**  on the camera.
2. The LCD monitor displays an image. To understand the icons and other information on the screen, please see "Photo Mode Screen Layout" on page 22.

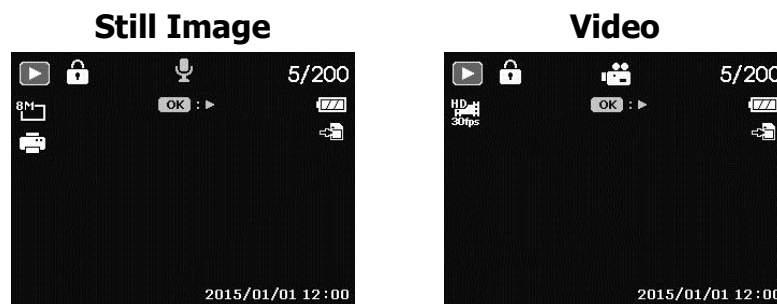

3. Use the ◀ or ▶ keys to view next/previous image/video.
4. To play a video clip, press the **OK** button. See "Playing Videos" on page 62 for more details.



When playing videos under playback mode, lens will retract after 15 seconds, but the video playback will still continue.

Viewing Thumbnails



This function allows you to view 9 or 36 thumbnail images on the LCD monitor at the same time. Searching numerous images is much easier than single view navigation.

To set 9-images or 36-images mode



1. Press the Playback button  on the camera.
2. Press the Zoom button (left) once to enter 9-images mode or twice to enter 36-images mode.
3. Use the navigation controls to move through the items.
4. Press the OK button to select the image and view it normally.

Navigation.

Playing Videos







1. Press the **Playback button**  on the camera.
2. Use the navigation controls to scroll through the saved images. A video clip has a video icon displayed on screen.
3. Press the **OK** button to play the video.
4. During playback, press and hold the ◀ or ▶ keys to fast forward or rewind the video. The camera supports forward and rewind speed of up to 4x.
5. During playback, use the **Zoom buttons** to control volume. Press the right button to increase volume/Press the left button to decrease volume.
6. Press the ▲ key to pause playback. Press the key ▲ again to resume. When paused, the play info will remain on screen except  .
7. To forward or rewind the video frame by frame, press the key ▲ to pause playback, then press the ◀ or ▶ keys.
8. Press the ▼ key to stop the playback. The LCD monitor will display the video frame image in Single navigation mode.



- The playback info, except the icon  , will be displayed when the video is paused, during REW/FF or frame by frame modes
- Volume cannot be adjusted when paused or during REW/FF modes.

Playing Voice Memo

Voice memo is separately recorded and attached to a captured image. See "Voice Memo" on page 67 on how to record voice memo.

1. Press the **Playback button**  on the camera.
2. Use the navigation controls to scroll through the saved images. An image file with voice memo has a voice memo icon located on the top center of the LCD monitor. See picture on the right.
3. Press the OK button to play the voice recording.
4. During playback, use the **Zoom buttons** to control volume. Press the right button to increase volume/Press the left button to decrease volume.
5. Press the key  to pause playback. Press the key  again to resume. When paused, the play info will remain on screen except  .
6. Press the key  to stop the playback. The LCD monitor displays the image in Single navigation mode.



Volume cannot be adjusted when you pause the voice memo.

Playback Menu

The Playback menu allows you to edit images, record voice memos, and setup playback settings.

To go to Playback Menu:

1. Press the **Playback button**  on the camera.
2. Press **Menu button** to launch the Playback Menu.
3. Use the **▲** or **▼** keys to move through the menu selections.
4. To select a menu, press **▶** or the **OK** button.
5. Change the submenu settings using the 4-way navigation control.
6. Press the **OK** button to save and apply settings.



Slideshow

The slideshow function enables you to playback your photos, videos and error files according to naming order.

To view Slideshow:

1. From the Playback menu, select **Slideshow**. The Slideshow menu appears.
2. Set the slideshow settings.
3. Select **Start**, then press the **OK** button to start the slideshow.
4. During Slide Show, press the **UP** button to pause slideshow.
5. Use the **▲** or **▼** keys to move through the options. Select whether to **Continue** or **Exit** the slideshow.
6. Press the **OK** button to apply selected option.

To change slide show settings:

1. From the slideshow menu, use the **▲** or **▼** keys to move through the selections.
2. Select Interval setting. Press the **◀** or **▶** keys to adjust. Choose among the available interval settings: 1 sec., 3 sec., 5 sec., and 10 sec.
3. Select Repeat setting. Press the **◀** or **▶** keys to adjust. Available settings are: Yes, No.

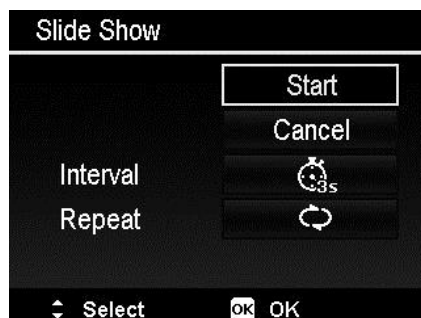

Protect

Set the data to read-only to prevent images from being erased by mistake.

A protected file has a lock icon  when viewed on Playback mode.

To protect files:

1. From the Playback menu, select **Protect**.
2. The Protect submenu is displayed on the LCD monitor.

Available select settings:

- **Single.** Select one file to lock/unlock.
- **Multi.** Select multiple files from the thumbnail view to lock/unlock.
- **Lock all.** Lock all files
- **Unlock all.** Unlock all files.

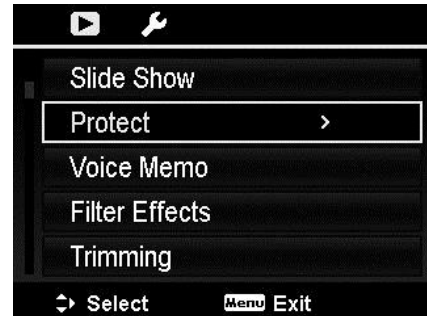

To protect/unprotect a single file:

1. Select **Single** in the Protect submenu, the images are displayed on the LCD monitor in single navigation mode.
2. Use **◀** or **▶** keys to scroll the display.
3. When the desired file is displayed on the LCD monitor, press the **OK** button to select **Lock/Unlock**.
4. To close the protect/unprotect function and go back to the Playback menu, select **Exit**.

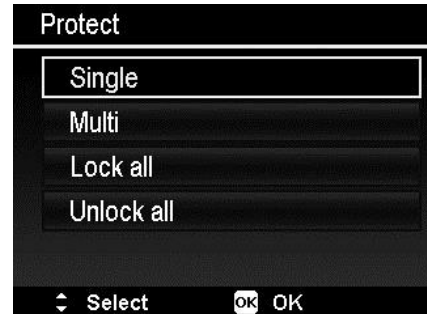

To protect/unprotect multiple files:

1. Select Multi in the Protect submenu, the images are displayed in thumbnail view on the LCD monitor.
2. Use the **◀** or **▶** keys to move through the files.
3. When the desired file is highlighted, use the **▲** or **▼** keys to mark/unmark the file for protection.
4. Repeat step 3 until all desired files to protect are marked.
5. Press the **OK** button to lock files and go back to Playback menu.

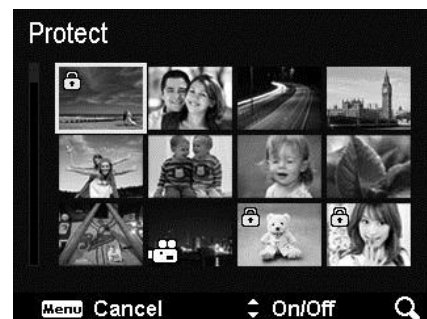

To protect all files:

1. Select **Lock all** in the Protect submenu. A confirmation message appears.
2. Select **Yes**.
3. Press the **OK** button to lock all files.

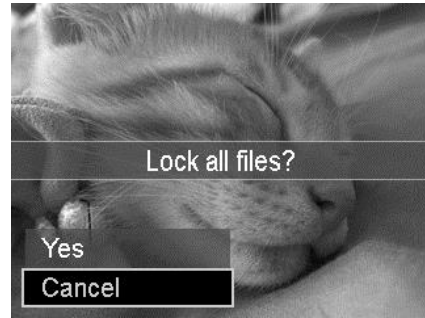

To unlock all files:

1. Select **Unlock all** in the Protect submenu. A confirmation message appears.
2. Select **Yes**.
3. Press the **OK** button to unlock all protected files.

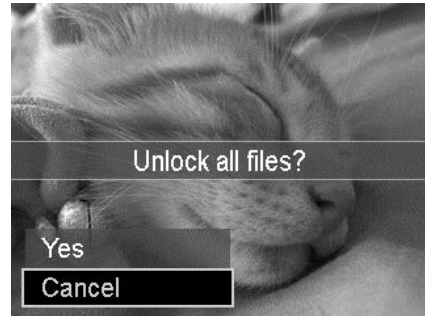

Voice Memo

A maximum of 30 seconds of audio can be recorded as a memo for captured still images.

To record voice memo:

1. Press the **Playback button**  on the camera.
2. Press the ◀ or ▶ keys to scroll and select an image to attach voice memo to.
3. Press the **MENU** button to launch the Playback menu.
4. Select **Voice Memo**.
5. Select **Start**, then press the **OK** button to start recording.
6. Press the **OK** button again to stop recording.

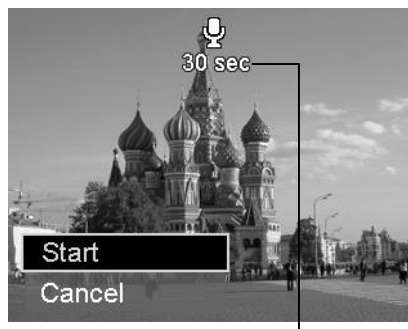
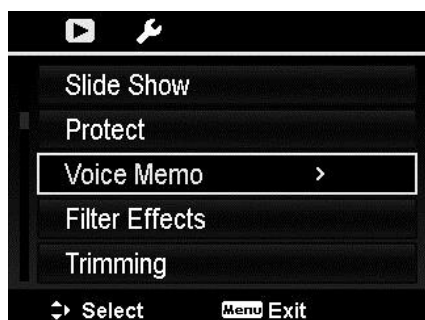

Time left (in seconds) for recording.



When you record a voice memo for an image with an existing voice memo, the old recording file would be replaced by the new one.

Filter Effects

Filter Effects function is only applicable to aspect ratio **4:3** photos with different artistic effect. Edited images in this function are saved as new files.

To activate Filter Effects:

1. Press the Playback button  on the camera.
2. Press the ◀ or ▶ keys to scroll and select an image to edit.
3. Press the **MENU** button to launch the Playback menu.
4. Select **Filter Effects**. The Filter Effects submenu appears.

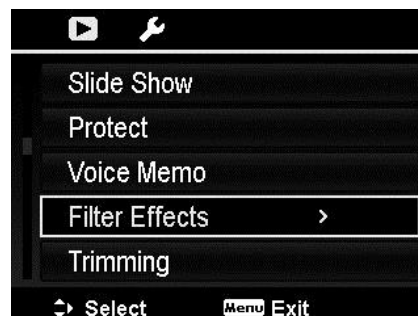

5. Press the ▲ or ▼ keys to scroll and **OK** button to select an option.

The succeeding table shows the available settings.

Soft	Image is applied with soft effect.
Color Emphasis	Retains the color tone you choose while the rest of the scene becomes black and white.
Vivid	Image is applied with more contrast and saturation emphasizing the bold colors.
Miniature Effect	Parts of the image will be blurred making the scene look like a miniature scale model. It is recommended to apply to an image that is captured from a high angle in order to help simulate the miniature effect.
Astral	Image is applied with starburst.
Impressive Art	Image is applied with dramatic contrast.
Painting	Image is applied with watercolor effect. Please note that if one image is applied with Painting function already, it cannot be applied with Astral again.
Negative	Image appears to be the opposite of the original image.
B&W	Image is applied with black and white.
Mosaic	Image is applied with mosaic tiles.
Sepia	Image is applied with sepia tones.

Trimming

The Trim function allows you to trim an image to another image size. This function is only available for still images.



To trim an image:

1. Press the Playback button  on the camera.
2. Press the ◀ or ▶ keys to scroll and select an image to trim.
3. Press the **MENU** button to launch the Playback menu.
4. Select **Trimming**. The Trim screen layout is displayed on the LCD monitor.
5. Use the **Zoom button** to change the trimming frame as zoom in/out.

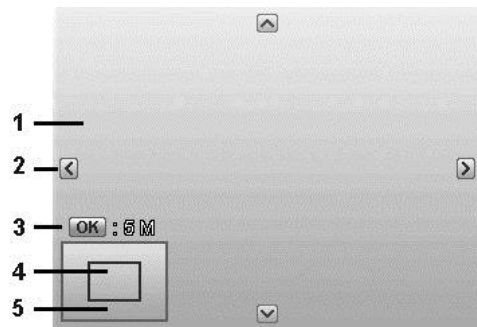

1	Enlarged image
2	4-way indicator
3	Trimmed size
4	The approx. location of the trimmed area
5	Image area



6. Use the navigation controls to move the image.
 7. Press the **OK** button to apply changes. A menu selection appears.
 8. Select whether to:
 - **Yes.** Save the new file as a new one.
 - **Cancel.** Cancel setting and go back to Playback Menu.
 9. Press the **OK** button to save/cancel changes.
-  • Trim function is not available for images with image size set to VGA.
-  • All images will be trimmed in 4:3 ratio regardless of its original image ratio.



Resize

Resizes a previously saved image to create a small copy photo. Only resizing to a smaller size is available.

To resize an image:

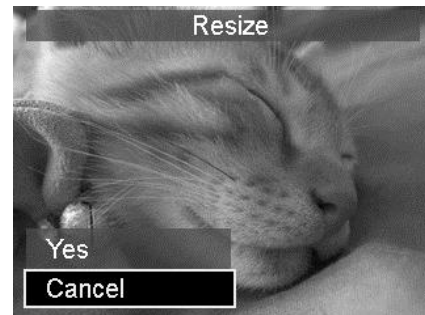
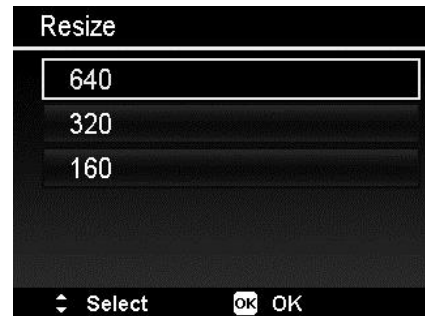
1. Press the **Playback button**  on the camera.
2. Use the ◀ or ▶ keys to scroll and select an image to resize.
3. Press the **MENU** button to launch the Playback menu.
4. Select **Resize**. The Resize submenu is displayed on the LCD monitor.
5. Select size among: 640, 320, and 160.
6. After selecting size, a menu selection appears.
7. Press the **OK** button to save/cancel changes.
8. The resized image is saved as a new photo.





-  • Resize function is only applicable to aspect ratio 4:3 photos.
-  • The original photos can be resized more than once. However, each resized photo cannot be resized again.

Startup Image

You can specify the startup image from the captured images of the camera.

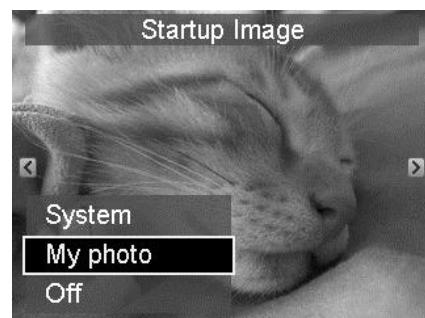
1. Press the **MENU** button to launch the Playback menu.
2. Select **Startup Image**. The menu selection appears.
3. Select options:
 - **System**. Use camera default image.
 - **My Photo**. Use the ◀ or ▶ keys to scroll and select desired image.
 - **Off**. Disable the startup image.
4. Press the **OK** button to apply changes.



-  • The startup image will still be displayed even if the selected image was deleted.

DPOF

DPOF is the abbreviation for Digital Print Order Format, which allows you to embed printing information on your memory card. You can select the images to be printed and how many prints to make with the DPOF menu in the camera and insert the memory card to the card compatible printer. When the printer starts printing, it will read the embedded information on the memory card and print the specified images.

To set DPOF:

1. Press the **Playback button**  on the camera.
2. Press **Menu button** to launch the Playback Menu.
3. Select **DPOF**. The submenu appears. Available settings are as follows:
 - **Select Images.** Mark images in the memory card.
 - **Reset.** Reset all DPOF settings to initial default settings.

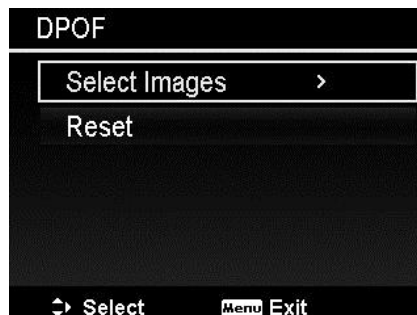

To set DPOF on images:

1. Select **Select Images** on the DPOF submenu.
2. Use the ◀ or ▶ keys to scroll and select images to mark for printing.
3. When the desired image is highlighted, use the ▲ or ▼ to increase/decrease number.
4. Press the **OK** button to define the DPOF settings and select **Done** to save DPOF settings.

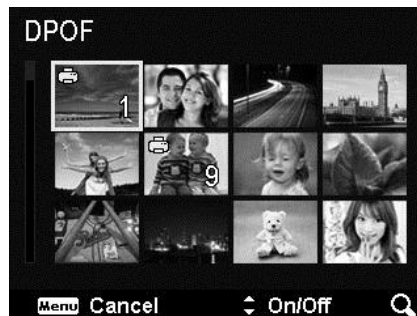

To reset DPOF:

1. Select **Reset** on the DPOF submenu.
2. The camera auto reset all DPOF settings.

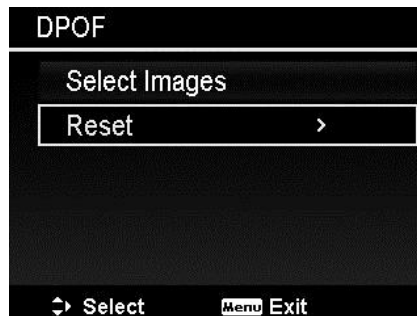

Copy

Use this feature to copy images between internal memory and memory card.

To copy images between internal memory and memory card:

1. Press the **Playback button**  on the camera.
2. Press **Menu button** to launch the Playback Menu.
3. Select **Copy** and choose a method you want to copy images to. After choosing, available settings are as follows:
 - **Selected images.** Select the chosen images on the storage device
 - **All images.** Copy all selected images to the storage device

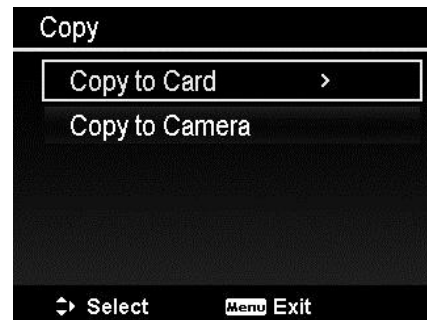

To copy selected images:

1. Select **Selected images** on the Copy submenu.
2. Use the ◀ or ▶ keys to scroll and select images to mark for Copying.
3. When the desired image is highlighted, use the ▲ or ▼ keys to mark/unmark the file for copying.
4. Press the **OK** button and select **Yes** to start copying.

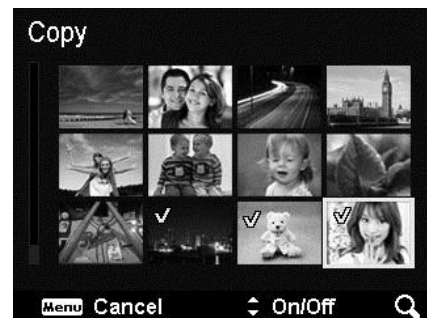

To copy all images:

1. Select **All images** on the Copy submenu.
2. Select **Yes** to start copying.

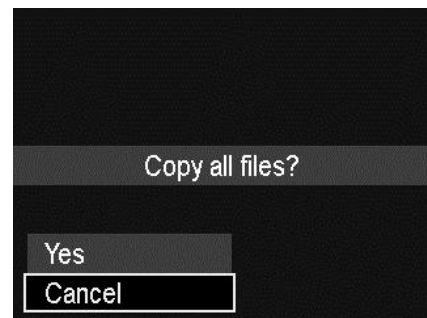

If no memory card or a locked card is inserted, this option would be grey.

Movie Paste

Use this feature to combine two videos with the same specification (movie size and fps) into one video.

To combine two videos:

1. Press the **Playback button**  on the camera.
2. Use the ◀ or ▶ keys to scroll and select the original video.
3. Press the **MENU** button to launch the Playback menu.
4. Select **Movie Paste**. The videos with the same specification as the original video are displayed on the LCD monitor.
5. Use the ◀ or ▶ keys to scroll and the ▲ or ▼ keys to mark/unmark the second video.
6. Press the **OK** button and select **Yes** to merge it to the end of the original video and overwrite it.



- The total length of the combined video cannot be over 30 minutes.
- After combining videos, the second video will no longer exist as a separate file.

Face Retouch

This function is only applicable to still images that were captured with Face Tracking.

When you enter the Face Retouch menu, if the photograph has over two faces locate the cursor on the picture, if the photograph has one face locate the cursor on the function at the right side of the menu.

Only one face can be retouched at a time. All functions will be reset to 0 when you exit from the Face Retouch menu, no matter whether you save the picture or cancel the setting.

Pictures that have been retouched will be saved as a new image and this function can be applied again.

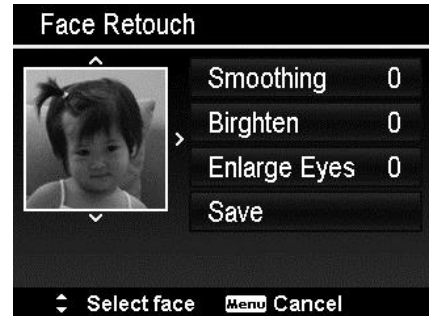

Smoothing	0-3	The Smoothing level is 0-3.
Brighten	0-3	The Brighten level is 0-3.
Enlarge Eyes	0-3	The Enlarge Eyes level is 0-3.
Save	N/A	Save the image.

Using the Setup Menu

You can access the Setup menu in Record or Playback mode.
The Setup menu allows you to configure general camera settings.

To go to Setup Menu:

1. Press **Menu** button to launch the Record/Playback Menu.
2. Use the ◀ or ▶ keys to switch the menu tab to **Setup** menu.
3. Use the ▼ or ▲ keys to move through the menu selections.
4. To select an item, press the **OK** button or ▶ key.
5. Change the submenu settings using the 4-way navigation control.
6. Press the **OK** button to save and apply settings.

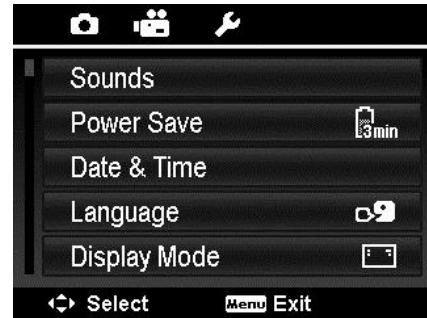

Setting Sounds

Use the Sound menu functions to control the sounds produced by the camera.

1. From the Setup menu, select **Sounds**.
2. Adjust sound settings.
3. Press the **OK** button to apply changes.



Startup	Sound 1, Sound 2, Sound 3, Off	Selects the startup sound when camera is turned on.
Shutter	On, Off	Enables or disables shutter sound when Shutter button is pressed. Shutter sound is not available when recording videos.
Beep volume	0-4	Adjusts volume.

Setting Power Save

The Power Save function allows you to set an idle time after which the camera automatically goes into sleep mode to save power. After a minute of being in sleep mode, the camera eventually turns off power.

This function is not available in the following instances:

- Recording a video file
- Playing a Slideshow/video file
- Using the USB connector
- AE/AF has been locked
- During Movie Paste
- During interval time on Time Lapse

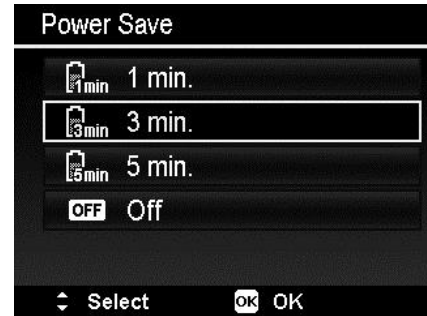

Setting Date & Time

Use the Date & Time function to set the date and time of your camera. This function is useful in attaching date stamps on captured images. Your camera uses a 24-hour time format.

1. Press the navigation controls to adjust date and time value. By holding down the ▼ or ▲ keys, the numeric values changes continuously.
2. Press the **OK** button to apply changes.



Setting Language

Specify in which language menus and messages are to be displayed on the LCD monitor.

1. Use the navigation control to scroll through the list and select the desired language.
2. Press the **OK** button to confirm and apply settings.



Setting Display Mode

This function controls the icon display on the LCD monitor for both Record mode and Playback mode.

Available settings are: On, Detailed Info, Off.

If you set Display Mode to Off, the mode icon and remaining shots will display for 2 seconds in the following situations:

- Power on the camera
- Switch from Playback to Record mode
- After shooting
- Close the menu and back to preview

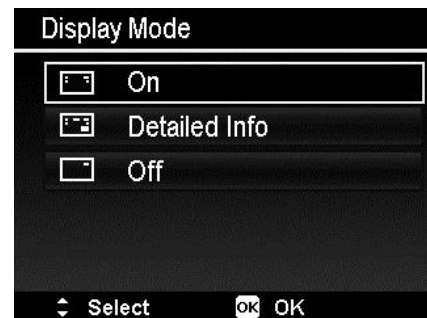

Setting TV Out

Use the TV Out function to adjust video output signal to accommodate different regional settings. If TV out is not set correctly, the image may not display properly on the TV.

Available settings are:

- **NTSC.** Applicable in Japan, USA, Canada, Taiwan and others.
- **PAL.** Applicable in Europe, Asia (excluding Taiwan), Oceania and others.



Setting LCD Brightness

Select a brightness level for the LCD monitor.
Available settings are:

- **Auto.** Auto detects the LCD brightness.
- **Bright.** Enhance the LCD brightness.
- **Normal.** Normal LCD brightness.

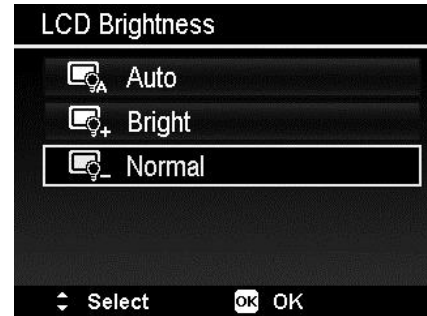

Setting Format

This utility formats current used memory (Internal memory or Memory card) and erases all stored images and data.



If a locked card has been inserted, the option would be grey.

Reset All

Use this function to reset the camera to its factory settings. However, the following settings are exceptions and are not affected by Reset.

- Date & Time
- Language
- TV Settings
- Custom White Balance data

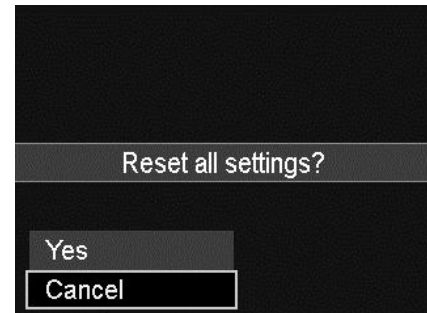

Making Connections

You can connect your camera to a: TV, computer, or a printer.

Connecting the Camera to a TV

You can play back your images on a TV screen. Before connecting to any video devices, make sure you select NTSC/PAL to match the broadcast standard of the video equipment you are going to connect to the camera.

To connect your camera to a TV:

1. Turn on the camera.
2. Set the TV to match the TV's video out format. See "Setting TV Out" on page 77.
3. Connect the USB/AV 2-in-1 cable to the USB port on the bottom of your camera.
4. Connect the other end of the cable to the TV's AV input port.
5. The LCD monitor turns black and all images and video clips are displayed on the TV.

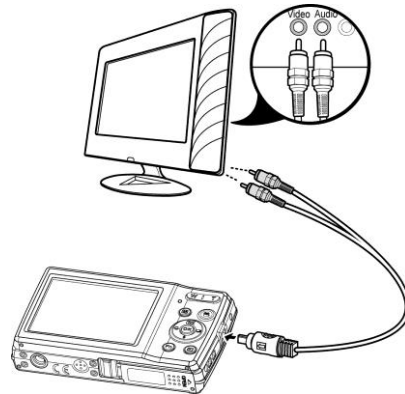

Connecting the Camera to a PC

You can transfer images and video files to your PC.

1. Connect one end of the USB cable to an available USB port on your computer
2. Connect the other end of the USB cable to the USB terminal on the camera.
3. Turn on the camera.
4. The PC starts to detect the connection while the LCD monitor appears **Connecting...**

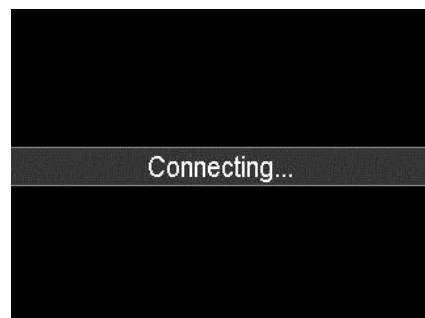
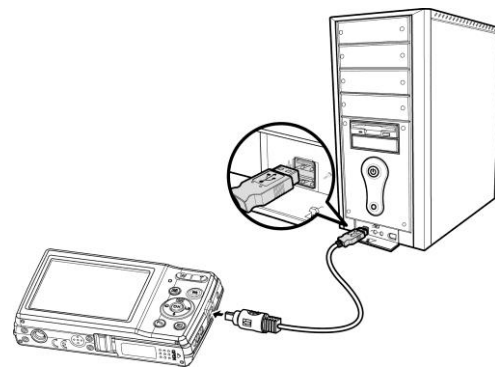

5. Connection established and the LCD monitor will be turned off.
6. Access the files in the camera by your PC.



- The camera's internal memory and memory card would display as removable drives in Vista/Win7/Win8 PC.
- When this camera is connected to your PC, two removable drives will display. Please click AP link (Magix) in the second drive, and then the Setup window will display (an Internet connection is required). After installation, you can import / edit your photos, movies and music. Please note that AP link (Magix) is the trial version and will be used permanently after registration.

Connecting the Camera to a Printer

You can print your images directly using a **PictBridge compatible** printer.

1. Turn on your Printer. Check that the printer is turned on, there is paper in the printer, and there are no printer error messages.
2. Connect one end of the USB cable to the printer and the other end to the USB terminal on the camera.
3. Enter the print mode and print the selected images.

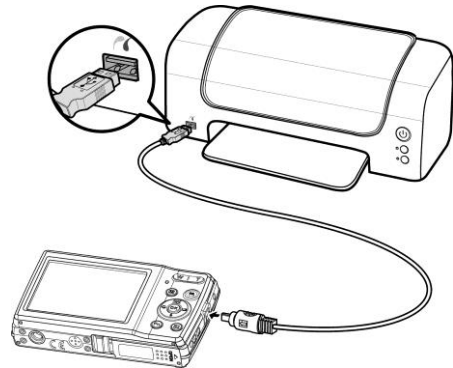

For more details on "Setting the Print Mode Menu" go onto next page.

Setting the Print Mode Menu

Print Mode menu appears on the screen after the connection between a printer and your camera is established.

Print Mode includes three major settings:

- **Print Select.** An image can then be selected to print.
- **Print All.** Prints all images.
- **Print DPOF.** Prints the images which are set DPOF.

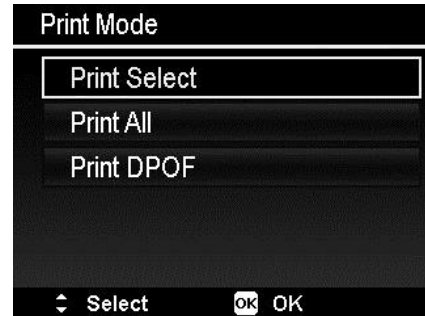

To set Print Select

1. Use the ◀ or ▶ keys to scroll and select an image for printing.
2. Specify the number of copies. Use the ▲ or ▼ key to increase/decrease number.
3. Press the **OK** button to enter printer settings.

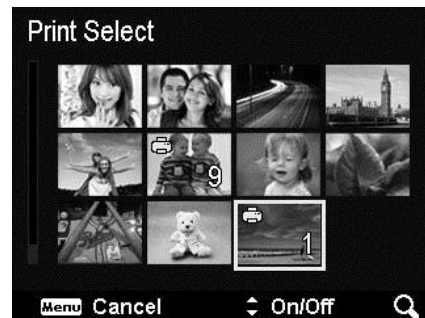

To set Print All and Print DPOF

Repeat the same steps 1 to 2, then enter printer settings.

To set Printer Settings

1. Use the ▲ or ▼ key to specify a print option.
2. Modify paper size, quality, date and info by the ◀ or ▶ keys. Available setting:
 - Paper size: Default / A4 / 4"x6"
 - Quality: Default / Fine / Normal
 - Capture Date: Yes / No
 - Capture Info: Yes / No
3. Select **Print** on the screen for printing.
Or **Cancel** to go back to Print Mode.

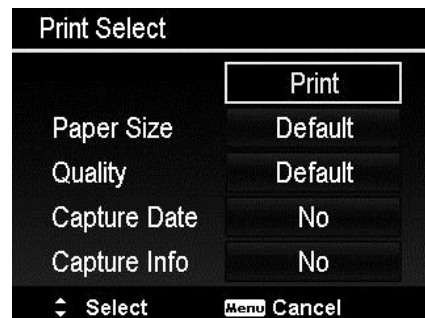

Start Printing

- LCD monitor appears "Now printing...".
- Or press Menu button to stop printing anytime.



Appendix

About Folder and File Names

Your camera automatically creates specific directories of folders in the internal memory cards to organize captured images and video files.

File Naming

File names begin with "DSCI" and followed by a 4-digit number that increases in sequence. File numbering starts from 0001 when a new folder is created.

The highest file number is 9999, if exceeds 9999, the camera will start over the file number from 0001.



Do not change the folder and file names in the memory card using your PC. It may be unable to playback the data using the camera.

Troubleshooting

Camera does not turn on.	The battery may be exhausted, charge or replace.
Camera turns off automatically.	<ul style="list-style-type: none">• Power Saving may have activated. Turn power back on.• The battery may be exhausted. Charge the battery.
Empty battery icon is displayed on the LCD, then the camera turns off.	Battery is exhausted, please replace or recharge.
LCD monitor displays "Not available for this file".	Function is only available for specific file types. File format is not supported.
LCD monitor displays "Memory full".	Memory card is full. Replace the memory card with a new one or delete unnecessary images.
LCD monitor displays "File locked".	This file is locked. Unlock the file. See "Protect" on page 65.

LCD monitor displays "Card locked".	The memory card is protected. Remove the card and slide the write-protect switch to its unlock position.
LCD monitor displays "Card error".	Memory card format is not supported by the camera. Please go to Setup menu to format the card.
LCD monitor displays "Memory card is damaged".	The card may be damaged. You can either change the card or wipe to clean the connected points.
LCD monitor displays "Copy error".	The memory card is protected. Remove the card and slide the write-protect switch to its unlock position. The memory card is full. Replace card or delete unnecessary files.
No image displays on the TV screen.	Incorrect TV-out type was selected. Set the correct TV-out type to match your TV system.
The lens got stuck up.	Do not force the lens to go back. The type of the battery used may be incorrect or the battery power level is too low. Change the battery or charge the battery before using the camera.

Specifications

Sensor	20M Pixels
Lens	Focal Length: 26 mm ~ 130 mm 5x optical zoom, 8x digital zoom
LCD monitor	2.7" Color LCD
Focusing Range	Normal: Wide: 5 cm ~ infinity Tele: 60 cm ~ infinity Macro: Wide: 5 cm ~ 100 cm Tele: 150 cm ~ 200 cm Super Macro: Wide: 3 cm
Aperture	Wide: F3.2; Tele: F6.4
Shutter	Shutter Speed: Auto: 1 - 1/2,000 sec. Manual: 15 - 1/2,000 sec. Night: 1/4 - 1/2,000 sec. Fireworks: 4 sec.
File Format	Still Image: EXIF 2.3 compatible format (JPEG compression) AVI (Video: MJPEG , Audio: mono) Audio: WAV
Resolution (Photo)	Aspect ratio 4:3 20M (5152 x 3864), 8M (3264 x 2448), 5M (2592 x 1944), 3M (2048 x 1536), VGA (640 x 480) Aspect ratio 3:2 5152 X 3435 Aspect ratio 16:9 14M (5152 x 2898), 2M (1920 x 1080) Aspect ratio 1:1 2992 x 2992

Resolution (Movie)	<ul style="list-style-type: none"> • 720p30 • VGAp30
Scene Mode	Intelligent Scene, Program, Portrait, Landscape, Sunset, Backlight, Kids, Night Scene, Fireworks, Snow, Sports, Party, Candlelight, Night Portrait, Soft Skin, Flowing Water, Food, Love Portrait, Self Portrait, D-Lighting, Time Lapse, Panorama, Art Effect
ISO Equivalent	Auto, ISO 100, ISO 200, ISO 400, ISO 800, ISO 1600, ISO 3200, ISO 6400
Maximum ISO Auto	ISO 200, ISO 400, ISO 800
White Balance	Auto White Balance, Daylight, Cloudy, Tungsten, Fluorescent 1, Fluorescent 2, Custom
Exposure Control	+2.0EV / +1.7EV / +1.3EV / +1.0EV / +0.7EV / +0.3EV / 0EV / -0.3EV / -0.7EV / -1.0EV / -1.3EV / -1.7EV / -2.0EV
Metering	Multi, Center, Spot
Self-timer	Off, 10 sec., 2 sec., Double
Flash	Auto Flash, Red-eye Reduction, Forced On, Slow Sync, Forced Off
Storage	Internal memory: 64MB flash memory External memory: SD (up to 4GB), SDHC card (up to 32GB guaranteed), SDXC card (up to 64GB guaranteed)
OSD Language	English, Français, Español, Deutsch, Italiano, Русский, Português, Português BR, Nederlands, Türkçe, Polski, Magyar, Română, Čeština, Български, Hrvatski, Slovensky, Slovenščina, Ελληνικά, Svenska, Norsk, Suomi, Danish, عربي, Indonesia, Malay, ไทย, 日本語, 한국어, 简体中文, 繁體中文
Interface	USB/AV OUT
TV system	NTSC/PAL (selected by Setup MENU)
Battery	Lithium ion battery
Battery Level	Full-Half (65% ± 15%) Half-Low (25% ± 15%) Low-Exhausted (10% ± 10%)
USB adapter	Rated input voltage: AC 100V-240V (160mA, 50/60Hz)

	Rated output voltage: DC 5V/1A Operating temperature: 0°C - 40°C
Operating Temperature	0°C - 40°C
Operating Humidity	0% - 90%
Microphone	Built-in
Speaker	Built-in
Dimensions	100.39 x 59.00 x 21.45 (mm)
Weight	103 g (no battery)