



FatTwin[®]
F629P3-RTB
F629P3-RTBN
F629P3-RC0B
F629P3-RC1B

USER'S MANUAL

Revision 1.0

The information in this User's Manual has been carefully reviewed and is believed to be accurate. The vendor assumes no responsibility for any inaccuracies that may be contained in this document, and makes no commitment to update or to keep current the information in this manual, or to notify any person or organization of the updates. **Please Note: For the most up-to-date version of this manual, please see our website at www.supermicro.com.**

Super Micro Computer, Inc. ("Supermicro") reserves the right to make changes to the product described in this manual at any time and without notice. This product, including software and documentation, is the property of Supermicro and/or its licensors, and is supplied only under a license. Any use or reproduction of this product is not allowed, except as expressly permitted by the terms of said license.

IN NO EVENT WILL Super Micro Computer, Inc. BE LIABLE FOR DIRECT, INDIRECT, SPECIAL, INCIDENTAL, SPECULATIVE OR CONSEQUENTIAL DAMAGES ARISING FROM THE USE OR INABILITY TO USE THIS PRODUCT OR DOCUMENTATION, EVEN IF ADVISED OF THE POSSIBILITY OF SUCH DAMAGES. IN PARTICULAR, SUPER MICRO COMPUTER, INC. SHALL NOT HAVE LIABILITY FOR ANY HARDWARE, SOFTWARE, OR DATA STORED OR USED WITH THE PRODUCT, INCLUDING THE COSTS OF REPAIRING, REPLACING, INTEGRATING, INSTALLING OR RECOVERING SUCH HARDWARE, SOFTWARE, OR DATA.

Any disputes arising between manufacturer and customer shall be governed by the laws of Santa Clara County in the State of California, USA. The State of California, County of Santa Clara shall be the exclusive venue for the resolution of any such disputes. Supermicro's total liability for all claims will not exceed the price paid for the hardware product.

FCC Statement: This equipment has been tested and found to comply with the limits for a Class A digital device pursuant to Part 15 of the FCC Rules. These limits are designed to provide reasonable protection against harmful interference when the equipment is operated in a commercial environment. This equipment generates, uses, and can radiate radio frequency energy and, if not installed and used in accordance with the manufacturer's instruction manual, may cause harmful interference with radio communications. Operation of this equipment in a residential area is likely to cause harmful interference, in which case you will be required to correct the interference at your own expense.

California Best Management Practices Regulations for Perchlorate Materials: This Perchlorate warning applies only to products containing CR (Manganese Dioxide) Lithium coin cells. "Perchlorate Material-special handling may apply. See www.dtsc.ca.gov/hazardouswaste/perchlorate".

WARNING: Handling of lead solder materials used in this product may expose you to lead, a chemical known to the State of California to cause birth defects and other reproductive harm.

The products sold by Supermicro are not intended for and will not be used in life support systems, medical equipment, nuclear facilities or systems, aircraft, aircraft devices, aircraft/emergency communication devices or other critical systems whose failure to perform be reasonably expected to result in significant injury or loss of life or catastrophic property damage. Accordingly, Supermicro disclaims any and all liability, and should buyer use or sell such products for use in such ultra-hazardous applications, it does so entirely at its own risk. Furthermore, buyer agrees to fully indemnify, defend and hold Supermicro harmless for and against any and all claims, demands, actions, litigation, and proceedings of any kind arising out of or related to such ultra-hazardous use or sale.

Manual Revision 1.0

Release Date: February 27, 2018

Unless you request and receive written permission from Super Micro Computer, Inc., you may not copy any part of this document. Information in this document is subject to change without notice. Other products and companies referred to herein are trademarks or registered trademarks of their respective companies or mark holders.

Copyright © 2018 by Super Micro Computer, Inc.
All rights reserved.

Printed in the United States of America

Preface

About this Manual

This manual is written for professional system integrators and PC technicians. It provides information for the installation and use of the FatTwin F629P3-RTB/RTBN/RC0B/RC1B. Installation and maintenance should be performed by experienced technicians only.

Please refer to the F629P3-RTB/RTBN/RC0B/RC1B server specifications page on our website for updates on supported memory, processors and operating systems (<http://www.supermicro.com>).

Notes

For your system to work properly, please follow the links below to download all necessary drivers/utilities and the user's manual for your server.

- Supermicro product manuals: <http://www.supermicro.com/support/manuals/>
- Product drivers and utilities: <ftp://ftp.supermicro.com>
- Product safety info: http://www.supermicro.com/about/policies/safety_information.cfm

If you have any questions, please contact our support team at:
support@supermicro.com

This manual may be periodically updated without notice. Please check the Supermicro website for possible updates to the manual revision level.

Warnings

Special attention should be given to the following symbols used in this manual.



Warning! Indicates important information given to prevent equipment/property damage or personal injury.



Warning! Indicates high voltage may be encountered when performing a procedure.

Contents

Chapter 1 Introduction

1.1 Overview.....	9
1.2 Unpacking the System	10
1.3 FatTwin: System Notes	10
Nodes	10
System Power	10
SAS/SATA/NVMe Backplane/Drives	10
1.4 System Features	11
1.5 Server Chassis Features.....	12
Control Panel	12
Front Features.....	13
Rear Features	14
1.6 Motherboard Layout	15
Quick Reference Table.....	16

Chapter 2 Server Installation

2.1 Overview.....	18
2.2 Preparing for Setup.....	18
Choosing a Setup Location.....	18
Rack Precautions	19
Server Precautions.....	19
Rack Mounting Considerations	19
Ambient Operating Temperature.....	19
Airflow	19
Mechanical Loading.....	20
Circuit Overloading	20
Reliable Ground.....	20
2-5 Rack Mounting Instructions.....	21
Identifying the Sections of the Rack Rails	22
Adjusting the Rails	22
Installing the Rails on a Rack	23
Chassis Installation	24

Chapter 3 Maintenance and Component Installation

3.1 Removing Power	25
3-2 Chassis Components	26
Removing Nodes from the Chassis	26
Removing the Cover from the Node	27
Node Configurations.....	28
Overview of the Node.....	28
F424AS2 Node Layout	28
Associated Hard Drives.....	29
Installing and Removing 3.5" Hard Drives	30
Removing the Rear Hard Drive Cage.....	32
Removing and Installing the Backplane.....	35
Removing the Backplane.....	35
Installing the Backplane	36
Removing the Rear Hard Drive Cage Backplane	37
Installing the Serverboard	38
Compatible Motherboards	38
Permanent and Optional Standoffs	38
Power Adapter Card Replacement	40
Installing Expansion Cards.....	41
F424AS2 PCI-E Slot Configurations.....	41
Installing the PCI-E Slot Bracket Assembly Into the Node	42
Installing a SIOM Module.....	43
Installing Air Shrouds	44
Removing and Installing System Fans	45
Replacing the Power Supplies	47
Power Supply Replacement.....	47
3.3 Motherboard Components.....	49
Processor and Heatsink Installation.....	49
The Processor.....	49
Overview of the Processor Socket Assembly	50
Overview of the Processor Heatsink Module.....	51
Preparing the CPU Socket for Installation	52
Removing the Dust Cover from the CPU Socket	52

Attaching the Processor to the CPU/Heatsink Carrier	53
Attaching the CPU/Carrier Assembly to the Passive Heatsink to Form the Processor Heatsink Module (PHM)	54
Installing the Processor Heatsink Module (PHM)	55
Removing the Processor Heatsink Module (PHM)	56
Memory Support and Installation	57
Memory Support	57
DIMM Population Requirements	57
DIMM Installation	61
DIMM Removal	61
Motherboard Battery	62
Chapter 4 Motherboard Connections	
4.1 Power Connections	63
4.2 Headers and Connectors	63
4.3 Rear I/O Ports	65
Ethernet Ports	66
4.4 Front Control Panel	67
4.5 Jumpers	70
Explanation of Jumpers	70
4.6 LED Indicators	72
4.7 PCI-E 3.0 Slots	73
Chapter 5 Software	
5.1 OS Installation	74
Installing the Windows OS for a RAID System	74
Installing Windows to a Non-RAID System	74
5.2 Driver Installation	75
5.3 SuperDoctor® 5	76
5.4 IPMI	77
Chapter 6 BIOS	
6.1 Introduction	78
Starting the Setup Utility	78
6.2 Main Menu	79
6.3 Advanced Settings Menu	81
6.4 Trusted Computing	110
6.5 Event Logs	113

6.6 IPMI	115
6.7 Security Settings	119
6.8 Boot Settings	122
6.9 Save & Exit.....	124

Appendix A BIOS Error Codes

Appendix B Standardized Warning Statements for AC Systems

Appendix C System Specifications

Appendix D UEFI BIOS Recovery

Contacting Supermicro

Headquarters

Address: Super Micro Computer, Inc.
980 Rock Ave.
San Jose, CA 95131 U.S.A.

Tel: +1 (408) 503-8000

Fax: +1 (408) 503-8008

Email: marketing@supermicro.com (General Information)
support@supermicro.com (Technical Support)

Website: www.supermicro.com

Europe

Address: Super Micro Computer B.V.
Het Sterrenbeeld 28, 5215 ML
's-Hertogenbosch, The Netherlands

Tel: +31 (0) 73-6400390

Fax: +31 (0) 73-6416525

Email: sales@supermicro.nl (General Information)
support@supermicro.nl (Technical Support)
rma@supermicro.nl (Customer Support)

Website: www.supermicro.nl

Asia-Pacific

Address: Super Micro Computer, Inc.
3F, No. 150, Jian 1st Rd.
Zhonghe Dist., New Taipei City 235
Taiwan (R.O.C)

Tel: +886-(2) 8226-3990

Fax: +886-(2) 8226-3992

Email: support@supermicro.com.tw

Website: www.supermicro.com.tw

Chapter 1

Introduction

1.1 Overview

This chapter provides a brief outline of the functions and features of the F629P3-RTB/RTBN/RC0B/RC1B. The F629P3-RTB/RTBN/RC0B/RC1B is based on the X11DPFR-S/SN motherboard and the F424AS2-R1K23BP chassis. This FatTwin system includes four motherboard tray nodes in the chassis.

In addition to the motherboard and chassis, several important parts that are included with the system are listed below.

Main Parts List		
Description	Part Number	Quantity
OCuLink v.1.0, 4x PCI-E, 37-cm cables (F629P3-RTBN only)	CBL-SAST-0974-1	8
2X mini-SAS HD to 2x SATA, 55-cm, AWG28 cables (F629P3-RTBN only)	CBL-SAST-1005-1	4
20 to 20-pin 7.5-cm, 28AWG backplane cables	CBL-OTHR-0022L	4
Internal mini-SAS HD to 4 SATA 50-cm, w/50cm SB cables (F629P3-RTB /F629P3-RTBN only)	CBL-SAST-0616	4
Mini-SAS HD to 4x SATA, 55-cm, AWG28 cables (F629P3-RTB only)	CBL-SAST-1004-1	4
Internal RA reverse Mini-SAS HD to 2x Mini-SAS HD Y-splitter 15/59-cm, 30AWG cables (F629P3-RC0B/F629P3-RC1B only)	CBL-SAST-0691	4
Internal RA reverse Mini-SAS HD to Mini-SAS HD 11-cm, 30AWG, 12Gb/s cables (F629P3-RC0B/F629P3-RC1B only)	CBL-SAST-0706	4
2x 3.5" HDD backplane (F629P3-RTB only)	BPN-SAS-F424-A2	4
6x 3.5" HDD backplane (F629P3-RTB /F629P3-RTBN only)	BPN-SAS-F424-A6	4
2-Port Hybrid Backplane supports 2x SAS3/SATA3/NVMe Storage Devices (F629P3-RTBN/F629P3-RC0B/F629P3-RC1B only)	BPN-SAS3-F424-A2N2A	4
Backplane for 6x 3.5" SAS3/SATA3 HDD/SSD (F629P3-RC0B/F629P3-RC1B only)	BPN-SAS3-F424-A6	4
2U passive CPU heat sink with a side air channel, equipped with a narrow retention mechanism	SNK-P0068PSC	4
1.5U proprietary 50-mm tall passive CPU heat sink with a side air channel	SNK-P0069PSC	4
Black gen 6.5 hot-swap 3.5 inch HDD trays	MCP-220-00094-0B	32
F424AS2 air shroud	MCP-310-42408-0B	4
80x80x38-mm, 13.5K RPM, HCP, LMV, and LPC Cooling Fan	FAN-0162L4	8
Fat twin F418/F424 static rail set support 28-33.5-inch depth rail	MCP-290-41803-0N	1

1.2 Unpacking the System

Inspect the box the SuperServer F629P3-RTB/RTBN/RC0B/RC1B was shipped in and note if it was damaged in any way. If any equipment appears damaged, please file a damage claim with the carrier who delivered it.

Decide on a suitable location for the rack unit that will hold the server. It should be situated in a clean, dust-free area that is well ventilated. Avoid areas where heat, electrical noise and electromagnetic fields are generated. It will also require a grounded AC power outlet nearby. Be sure to read the precautions and considerations noted in Appendix B.

1.3 FatTwin: System Notes

As a FatTwin configuration, the FatTwin F629P3-RTB/RTBN/RC0B/RC1B is a unique server system. With four system boards incorporated into a single chassis acting as four separate nodes, there are several points you should keep in mind.

Nodes

Each of the four serverboards act as a separate node in the system. As independent nodes, each may be powered off and on without affecting the others. In addition, each node is a hot-swappable unit that may be removed from the chassis. The nodes are connected to the server backplane by means of an adapter card.

Note: A guide pin is located between the upper and lower nodes on the inner chassis wall. This guide pin also acts as a “stop” when a node is fully installed. If too much force is used when inserting a node this pin may break off. Take care to slowly slide a node in until you hear the “click” of the locking tab seating itself.

System Power

Four 1200 Watt power supplies are used to provide the power for all serverboards. Each serverboard however, can be shut down independently of the others with the power button on its own control panel.

SAS/SATA/NVMe Backplane/Drives

As a system, the FatTwin F629P3-RTB/RTBN/RC0B/RC1B supports the use of eight (8) SAS/SATA, or six (6) SAS/SATA drives and two (2) NVMe 3.5" drives in front-mounted hot-swap drive trays per node, for a total of thirty-two (32) HDD drives in the system. Each of the eight backplanes works to apply system-based control for power and fan speed functions, yet at the same time logically connects a set of eight (8) SAS/SATA, or six (6) SAS/SATA drives and two (2) 3.5" NVMe drives to each backplane/serverboard. Consequently, RAID setup is limited to an eight-drive scheme (RAID cannot be spread across all drives). See Chapter 6 for the logical hard drive and node configuration.

1.4 System Features

The following table provides you with an overview of the main features of the F629P3-RTB/RTBN/RC0B/RC1B. Please refer to Appendix C for additional specifications.

System Features
Motherboard
X11DPFR-S/SN
Chassis
F424AS2-R1K23BP
CPU
Dual Intel Xeon 81xx/61xx/51xx/41xx/31xx series which offer 2 UPI (UltraPath Interconnect) of up to 10.4GT/s Note: Both CPUs need to be installed for full access to the PCI-E slots, DIMM slots, and onboard controllers. Refer to the block diagram on page 16 to determine which slots or devices may be affected.
Socket Type
Socket P
Memory
Integrated memory controller supports up to 1536 GB of ECC Load Reduced DIMM (LRDIMM), Registered DIMM (RDIMM), and Non-Volatile DIMM (NV-DIMM) DDR4 (288-pin) 2666/2400/2133 Mhz modules in twelve (12) slots
Chipset
Intel C621 chipset
Expansion Slots
One (1) PCI-Express 3.0 (x16) slot One (1) PCI-Express 3.0 x16 (x8 + x8) SMCI storage Slot (JSXB2) One (1) PCI-Express 3.0 x16 SIOM LAN Port
Hard Drives
The amount and type of hard drives in the system depends upon the model number as follows: F629P3-RTB: eight (8) 3.5" SATA3 drives F629P3-RTBN: six (6) 3.5" SATA3 and two (2) 2.5" NVME/SATA3 drives F629P3-RC0B/F629P3-RC1B: eight 3.5" SAS3/SATA3 drives
Power
Four 1200 Watt redundant power supplies
Cooling
Up to two (2) 8-cm cooling fans for each of the system's four serverboard nodes
Form Factor
Proprietary: (LxW): 9.66" x 8.53" (216.66 mm x 499.36 mm)
Dimensions
Chassis dimensions: (WxHxD) 17.63 x 6.96 x 29 in. (448 x 177 x 737 mm)

1.5 Server Chassis Features

Control Panel

The switches and LEDs located on the control panel are described below. See Chapter 4 for details on the control panel connections.

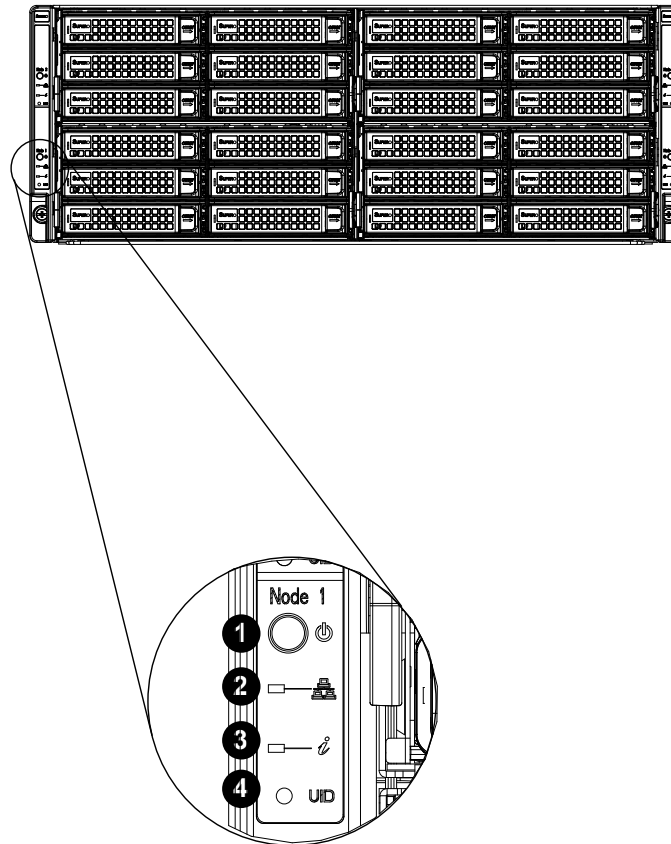

Figure 1-1. Control Panel View

Control Panel Features		
Item	Feature	Description
1	Power Button	The main power button on each of the eight control panels is used to apply or remove power from the power supply to each of the eight systems in the chassis. Turning off system power with this button removes the main power, but keeps standby power supplied to the system. Therefore, you must unplug system before servicing. The power button has a built-in LED which will turn green when the power is on.
2	NIC	Indicates network activity on either LAN1 or LAN2 when flashing.
3	Information LED	See the table below for full details on the Information LED.
4	UID LED	When used with a UID compatible serverboard, the UID indicator is used to turn on or off the blue light function of the LED. This is built into the front side of the UID button and at the rear end of each serverboard node, for those motherboards which support it. Once the blue light is activated, the unit can be easily located in very large racks and server banks.

Information LED	
Status	Description
Continuously on and red	An overheat condition has occurred. (This may be caused by cable congestion.)
Blinking red (1 Hz)	Fan failure: check for an inoperative fan.
Blinking red (0.25 Hz)	Power failure: check for an inoperative power supply.
Solid blue	Local UID has been activated. Use this function to locate the server in a rack environment.
Blinking blue (300 msec)	Remote UID has been activated. Use this function to locate the server from a remote location.

Front Features

The F424AS2-R1K23BP is a 4U chassis with four server nodes. See the illustration below for the features included on the front of the chassis.

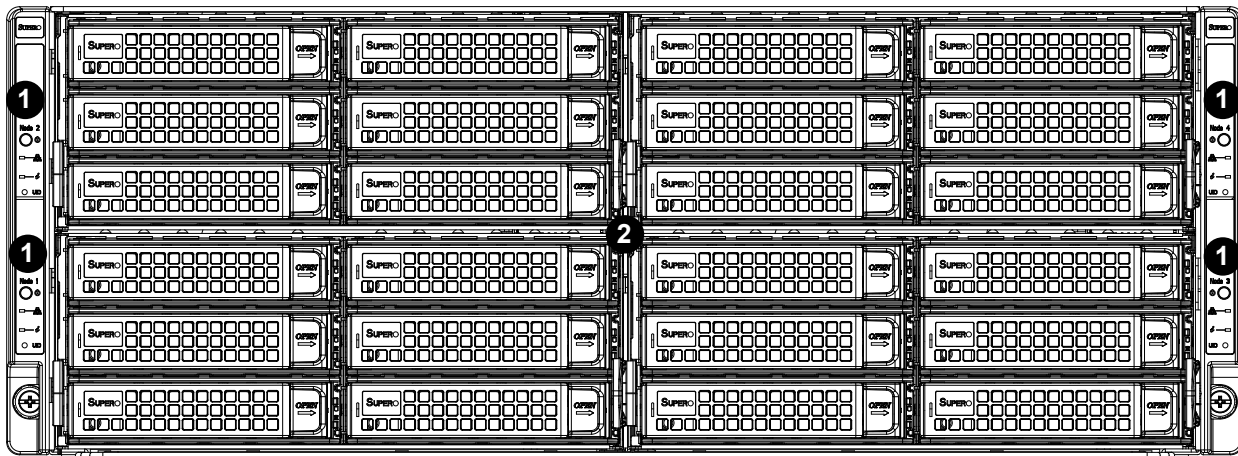

Figure 1-2. Chassis Front View

Front Chassis Features		
Item	Feature	Description
1	Node Control Panels (4)	See the section for Control Panel above for details.
2	Drive Bays	Each node has six (6) bays in the front for 3.5" HDD/SSD/NVMe drives. The configuration of each drive depends upon the server model.

Rear Features

The illustration below shows the features included on the rear of the chassis.

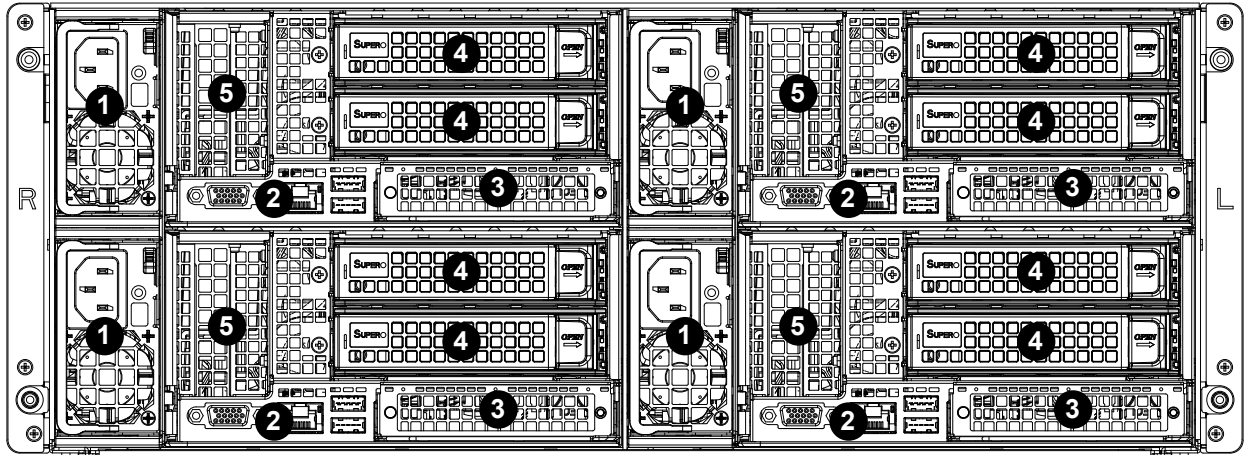

Figure 1-3. Chassis Rear View

Rear Chassis Features		
Item	Feature	Description
1	Power Supply	Four (4) redundant 1200 Watt power supplies are at rear of the chassis
2	Rear I/O Ports	Each node has its own rear I/O ports. See Chapter 3 for I/O port descriptions.
3	SIOM Module Bay	Each node has one rear SIOM module bay available for additional I/O ports.
4	Rear Drive Bays	Each node has two (2) bays in the rear for 3.5" HDD/SSD/NVMe drives. The configuration of each drive depends upon the server model.
5	Expansion Card Slots	Each node has one (1) rear expansion card slots available for access.

1.6 Motherboard Layout

Below is a layout of the X11DPFR-S/SN with jumper, connector and LED locations shown. See the table on the following page for descriptions. For detailed descriptions, pinout information and jumper settings, refer to Chapter 4.

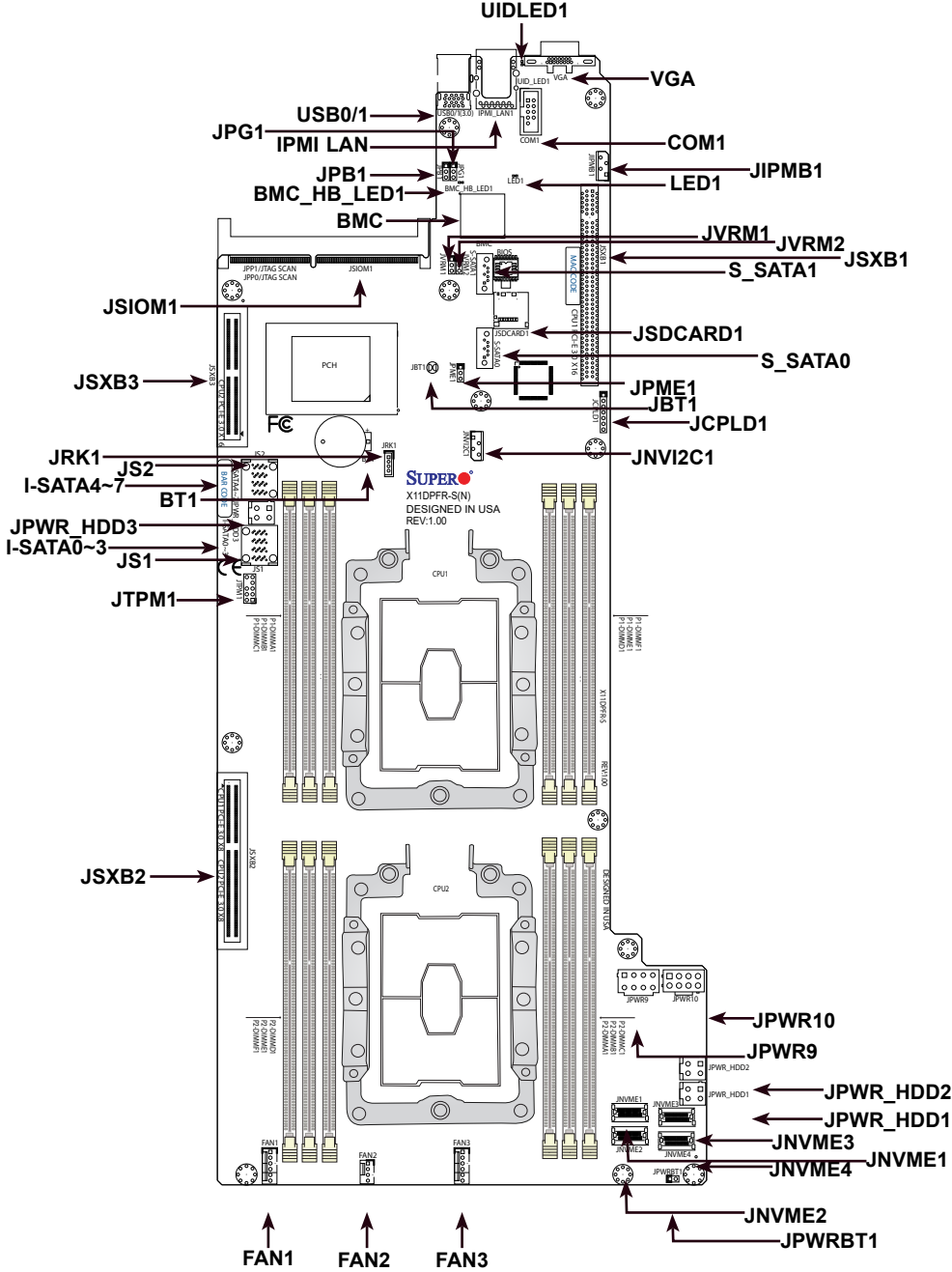

Figure 1-4. Motherboard Layout

Notes:

- See Chapter 4 for detailed information on jumpers, I/O ports, and JF1 front panel connections.
- Jumpers/LED indicators not indicated are used for internal testing only.

Quick Reference Table

Jumper	Description	Default Setting
JBT1	Clear CMOS	Open (Normal)
JPME1	ME Recovery	Pins 1-2 (Normal)
JVRM1	VRM SMB Clock (to BMC or PCH)	Pins 1-2 (BMC, Normal)
JVRM2	VRM SMB Data (to BMC or PCH)	Pins 1-2 (BMC, Normal)

Connector	Description
Battery (BT1)	Onboard CMOS battery
FAN1~3	System cooling fan headers
IPMI_LAN	Dedicated IPMI LAN port
JIPMB1	4-pin external BMC I ² C header (for an IPMI card)
JNVME1~4	NVMe OcuLink Ports
JNVI ² C1	NVMe I ² C header
JPWR9/JPWR10	8-pin Power Connector 9 (12V_in)/Power Connector 10 (Ground)
JPWR_HDD1/2/3	HDD Power headers 1/2/3
JRK1	RAID Key for NVMe devices
JS1/2	MiniSAS HD SATA 3.0 Ports
JSDCARD1	Micro SD Card slot
JTPM1	Trusted Platform Module (TPM) connector
(I-)SATA0~3, 4~7	I- SATA 3.0 connectors supported by the Intel PCH
(S-)SATA0/1	S-SATA 3.0 connectors supported by the Intel PCH
JSXB1	PCI-E 3.0 x16 Right hand riser (CPU1)
JSXB2	PCI-E 3.0 (x8+x8) SMCI Proprietary slot (CPU1 & CPU2)
JSXB3	PCI-E 3.0 x16 Left hand riser (CPU2)
USB0/1	Back panel USB 3.0 ports
VGA	Back panel VGA port

LED	Description	State: Status
UID_LED1	UID (Unit Identifier) LED	Solid Blue: Unit Identified
LED1	Onboard Power LED	On: Onboard Power On
BMC_HB_LED1	BMC Heartbeat LED	Blinking Green: BMC Normal

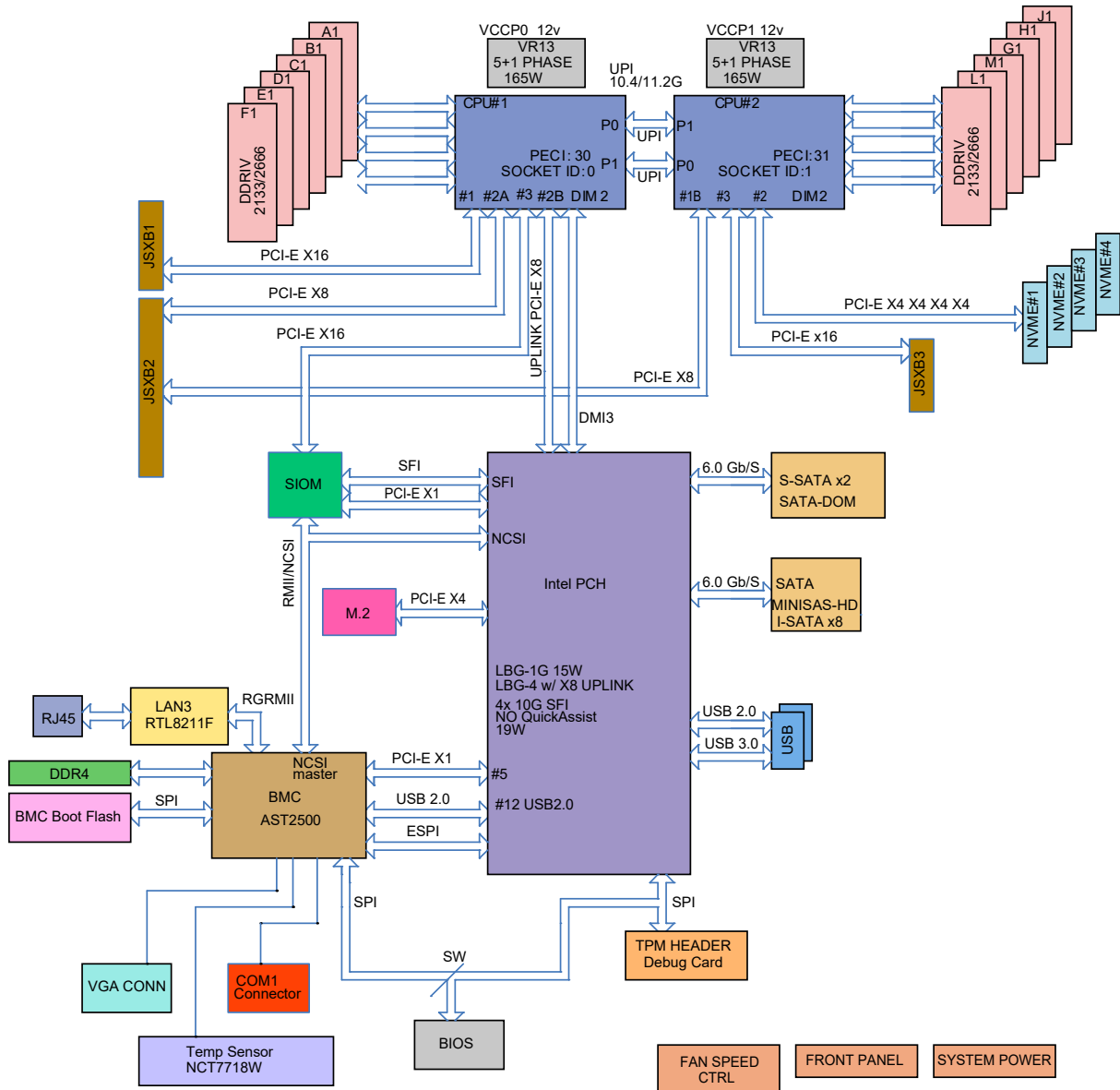

Figure 1-5. Intel C621 Chipset: System Block Diagram

Note: This is a general block diagram and may not exactly represent the features on your motherboard. See the System Specifications appendix for the actual specifications of your motherboard.

Chapter 2

Server Installation

2.1 Overview

This chapter provides advice and instructions for mounting your system in a server rack. If your system is not already fully integrated with processors, system memory etc., refer to Chapter 4 for details on installing those specific components.

Caution: Electrostatic Discharge (ESD) can damage electronic components. To prevent such damage to PCBs (printed circuit boards), it is important to use a grounded wrist strap, handle all PCBs by their edges and keep them in anti-static bags when not in use.

2.2 Preparing for Setup

The box in which the system was shipped should include the rackmount hardware needed to install it into the rack. Please read this section in its entirety before you begin the installation.

Choosing a Setup Location

- The system should be situated in a clean, dust-free area that is well ventilated. Avoid areas where heat, electrical noise and electromagnetic fields are generated.
- Leave enough clearance in front of the rack so that you can open the front door completely (~25 inches) and approximately 30 inches of clearance in the back of the rack to allow sufficient space for airflow and access when servicing.
- This product should be installed only in a Restricted Access Location (dedicated equipment rooms, service closets, etc.).
- This product is not suitable for use with visual display workplace devices according to §2 of the German Ordinance for Work with Visual Display Units.

Rack Precautions

- Ensure that the leveling jacks on the bottom of the rack are extended to the floor so that the full weight of the rack rests on them.
- In single rack installations, stabilizers should be attached to the rack. In multiple rack installations, the racks should be coupled together.
- Always make sure the rack is stable before extending a server or other component from the rack.
- You should extend only one server or component at a time - extending two or more simultaneously may cause the rack to become unstable.

Server Precautions

- Review the electrical and general safety precautions in Appendix B.
- Determine the placement of each component in the rack *before* you install the rails.
- Install the heaviest server components at the bottom of the rack first and then work your way up.
- Use a regulating uninterruptible power supply (UPS) to protect the server from power surges and voltage spikes and to keep your system operating in case of a power failure.
- Allow any drives and power supply modules to cool before touching them.
- When not servicing, always keep the front door of the rack and all covers/panels on the servers closed to maintain proper cooling.

Rack Mounting Considerations

Ambient Operating Temperature

If installed in a closed or multi-unit rack assembly, the ambient operating temperature of the rack environment may be greater than the room's ambient temperature. Therefore, consideration should be given to installing the equipment in an environment compatible with the manufacturer's maximum rated ambient temperature (TMRA).

Airflow

Equipment should be mounted into a rack so that the amount of airflow required for safe operation is not compromised.

Mechanical Loading

Equipment should be mounted into a rack so that a hazardous condition does not arise due to uneven mechanical loading.

Circuit Overloading

Consideration should be given to the connection of the equipment to the power supply circuitry and the effect that any possible overloading of circuits might have on overcurrent protection and power supply wiring. Appropriate consideration of equipment nameplate ratings should be used when addressing this concern.

Reliable Ground

A reliable ground must be maintained at all times. To ensure this, the rack itself should be grounded. Particular attention should be given to power supply connections other than the direct connections to the branch circuit (i.e. the use of power strips, etc.).



To prevent bodily injury when mounting or servicing this unit in a rack, you must take special precautions to ensure that the system remains stable. The following guidelines are provided to ensure your safety:

- This unit should be mounted at the bottom of the rack if it is the only unit in the rack.
- When mounting this unit in a partially filled rack, load the rack from the bottom to the top with the heaviest component at the bottom of the rack.
- If the rack is provided with stabilizing devices, install the stabilizers before mounting or servicing the unit in the rack.

2-5 Rack Mounting Instructions

This section provides information on installing the chassis into a rack unit with the rails provided. There are a variety of rack units on the market, which may mean that the assembly procedure will differ slightly from the instructions provided. You should also refer to the installation instructions that came with the rack unit you are using.

Note: This rail will fit a rack between 26.5" and 36.4" deep. The F424AS2 is not designed for installation into a Telco post-style rack unit. **Warning:** Do not pick up the server with the front handles. They are designed to pull the system from a rack only.



Stability Hazard: The rack stabilizing mechanism must be in place, or the rack must be bolted to the floor before you slide the unit out for servicing. Failure to stabilize the rack can cause the rack to tip over.



Warning: Slide rail mounted equipment is not to be used as a shelf or a work space.

Warning: When initially installing the server to a rack, test that the rail locking tabs engage to prevent the server from being overextended. Have a rack lift in place as a precaution in case the test fails.

Warning: In any instance of pulling the system from the rack, always use a rack lift and follow all associated safety precautions.

Identifying the Sections of the Rack Rails

The chassis package includes two rail assemblies in the rack mounting kit. Each assembly consists of two sections: A front section which secures to the front post of the rack and a rear section which adjusts in length and secures to the rear post of the rack. These assemblies are specifically designed for the left and right side of the chassis (see Figure 2-1).

Adjusting the Rails

Each rail assembly has an adjusting screw. Loosening this screw allows you to adjust the length of the rail to fit a variety of rack sizes.

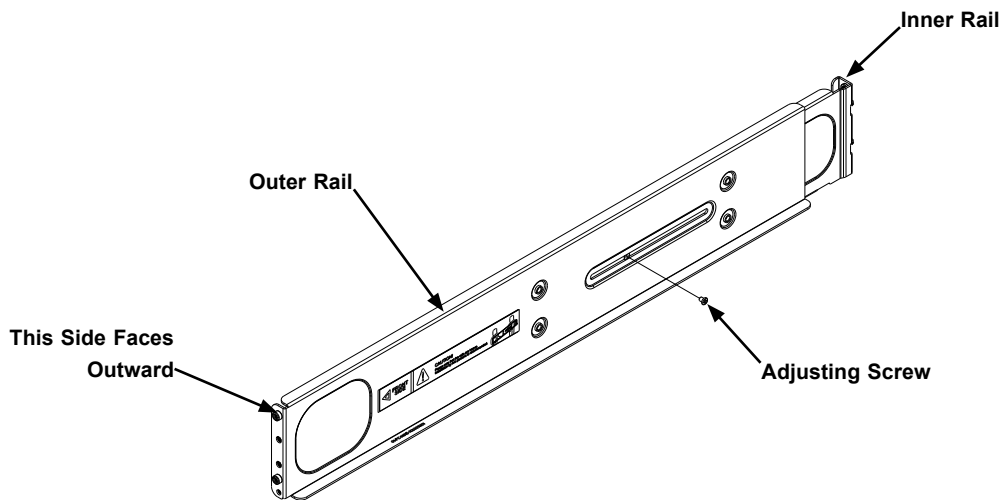

Figure 2-1. Identifying the Rail Sections



Slide rail mounted equipment is not to be used as a shelf or a work space.



Warning: do not pick up the server with the front handles. They are designed to pull the system from a rack only.

Installing the Rails on a Rack

Installing the Rails

1. Adjust the length of both rails as described on the previous page.
2. Align the front section of the outer rail with the slots on the front post of the rack. Secure the front of the outer rail to the rack with two screws.
3. Pull out the rear section of the outer rail, adjusting the length until it fits within the posts of the rack.
4. Align the rear section of the rail with the slots on the rear post of the rack. Secure the rear of the outer rail to the rear of the rack with two screws.
5. Repeat steps 1-4 for the remaining rail.

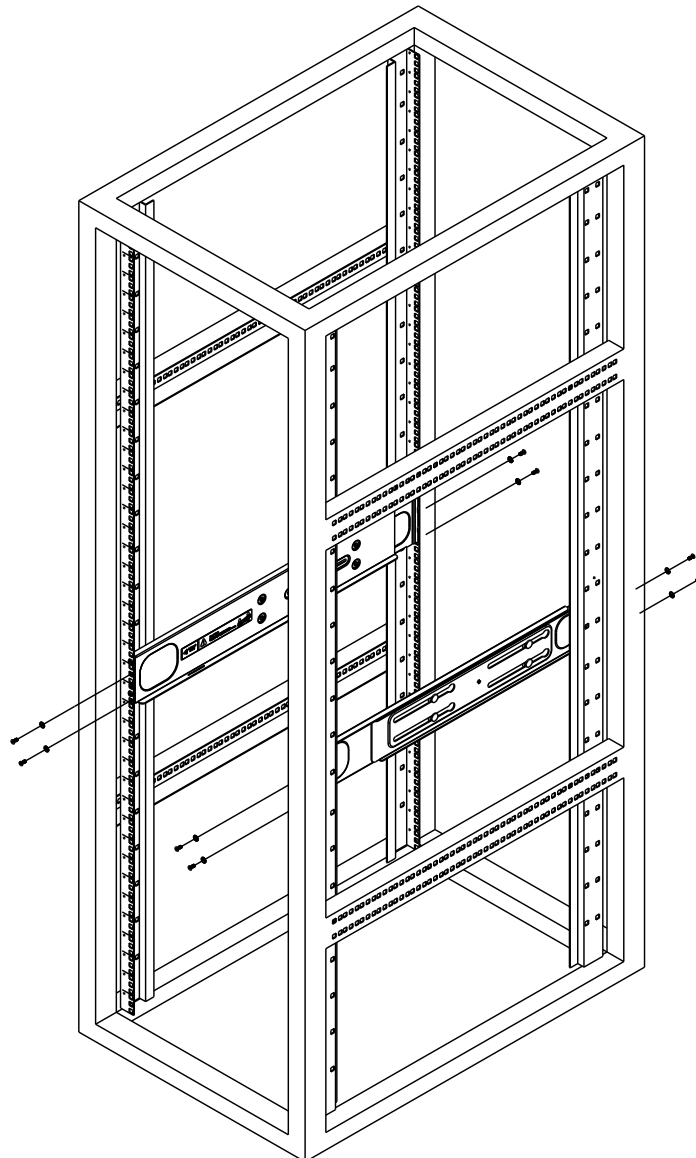

Figure 2-2: Attaching the Rails to a Rack

Chassis Installation

Installing the Chassis into a Rack

1. Confirm that the rails are correctly installed on the rack.
2. Align the bottom of the chassis with the bottom of the rails.
3. Insert the chassis into the rails, keeping the pressure even on both sides, pushing the chassis into the rack.
4. Secure the chassis handles to the front of the rack.

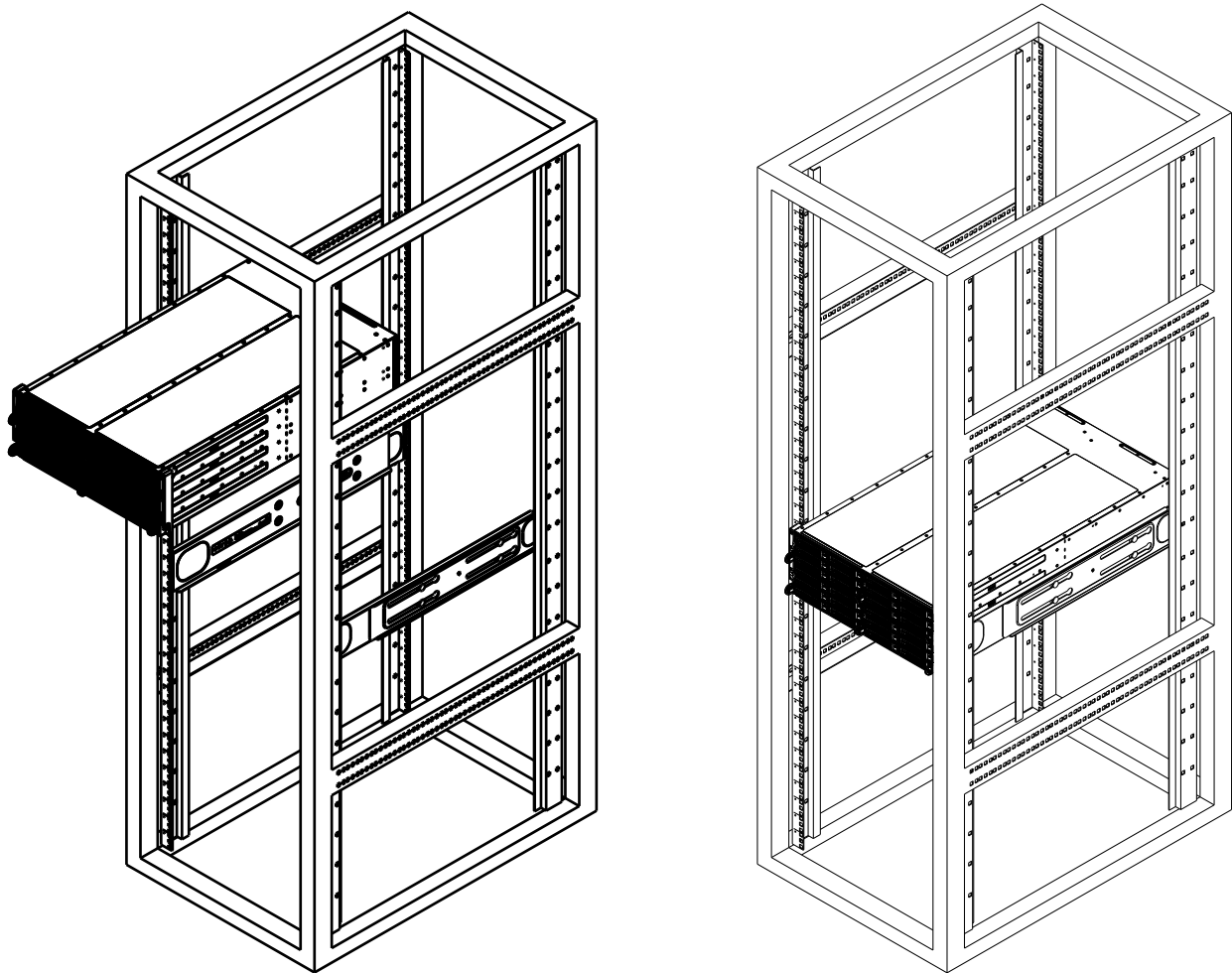

Figure 2-3: Installing into a Rack

Note: The figure above is for illustration purposes only. Always install servers to the bottom of the rack first.

Note: Both front chassis rails and the rack rails have a locking tab, which serves two functions. First, it locks the server into place when installed and pushed fully into the rack (its normal operating position). In addition, these tabs lock the server in place when fully extended from the rack. This prevents the server from coming completely out of the rack when pulled out for servicing.

Chapter 3

Maintenance and Component Installation

This chapter provides instructions on installing and replacing main system components. To prevent compatibility issues, only use components that match the specifications and/or part numbers given.

Installation or replacement of most components require that power first be removed from the system. Please follow the procedures given in each section.

3.1 Removing Power

Use the following procedure to ensure that power has been removed from the system. This step is necessary when removing or installing non hot-swap components or when replacing a non-redundant power supply.

Removing the Power Cord

1. Use the operating system to power down the system, following the on-screen prompts.
2. After the system has completely shut-down, carefully grasp the head of the power cord and gently pull it out of the back of the power supply.
3. If your system has dual redundant power supplies, remove the cords from both power supplies.
4. Disconnect the cord from the power strip or wall outlet.

3-2 Chassis Components

The chassis includes power supplies, rear I/O ports, expansion card slots and four nodes. Each node is a separate system containing a drawer with a serverboard, fans, and other components. Each node may be removed from the chassis separately.

Removing Nodes from the Chassis

Each of the four individual serverboard nodes may be removed from the chassis. Note that any time a node is removed from the chassis, the hard drives located in the node will shut-down.

Removing a Serverboard Node

1. Power down the system and remove the power cords from the rear of the node as described in Section 3-1.
2. Grasp the node by the handles on both sides of the front of the node.
3. Press down on the left handle to disengage the latch.
4. While holding down the left handle, carefully pull the node forward and out of the chassis.

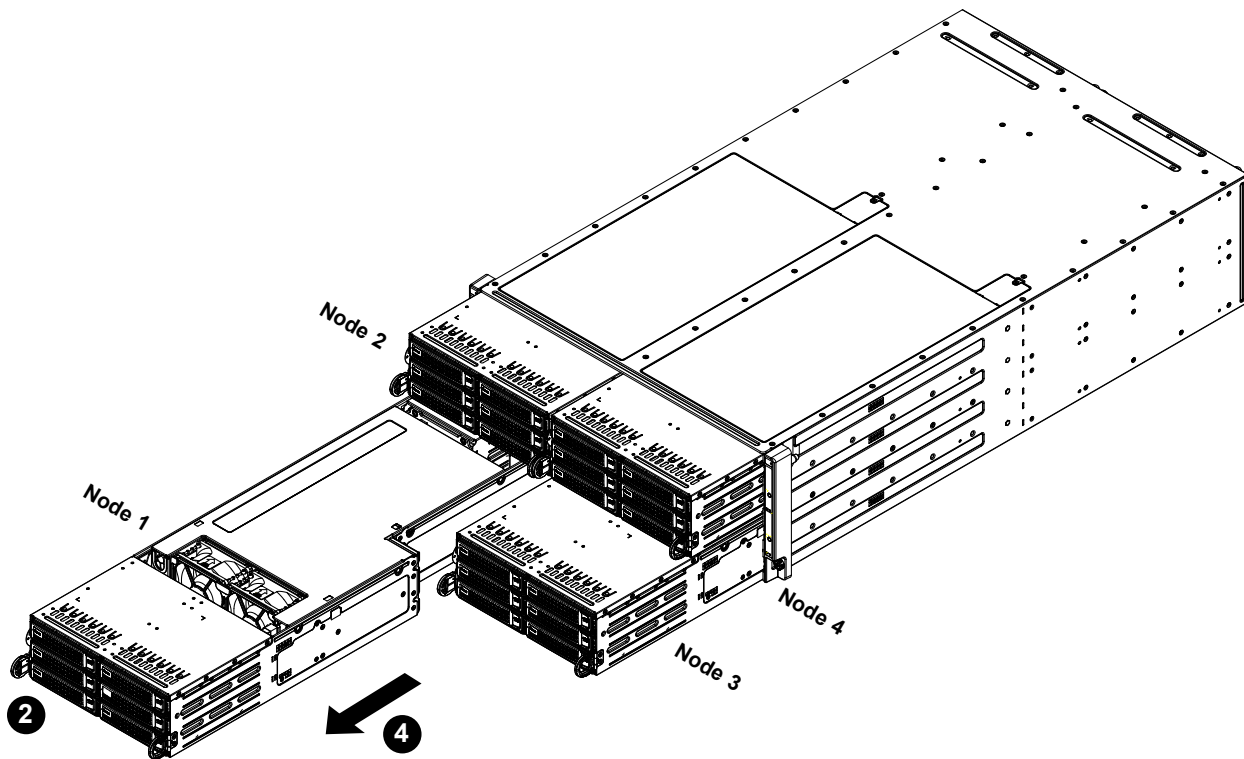

Figure 3-1. Nodes Corresponding to Locations in the Chassis

Warning: Except for short periods of time, do not operate the server without the cover in place. The chassis cover must be in place to allow for proper airflow and to prevent overheating.

Removing the Cover from the Node

Each node has a removable cover which will permit access to the nodes components.

Removing the Node Cover

1. Remove the serverboard node completely from the chassis and place it on a flat, stable surface.
2. Remove the screw securing the cover to the node, as illustrated below.
3. Lift the cover up and off the node.

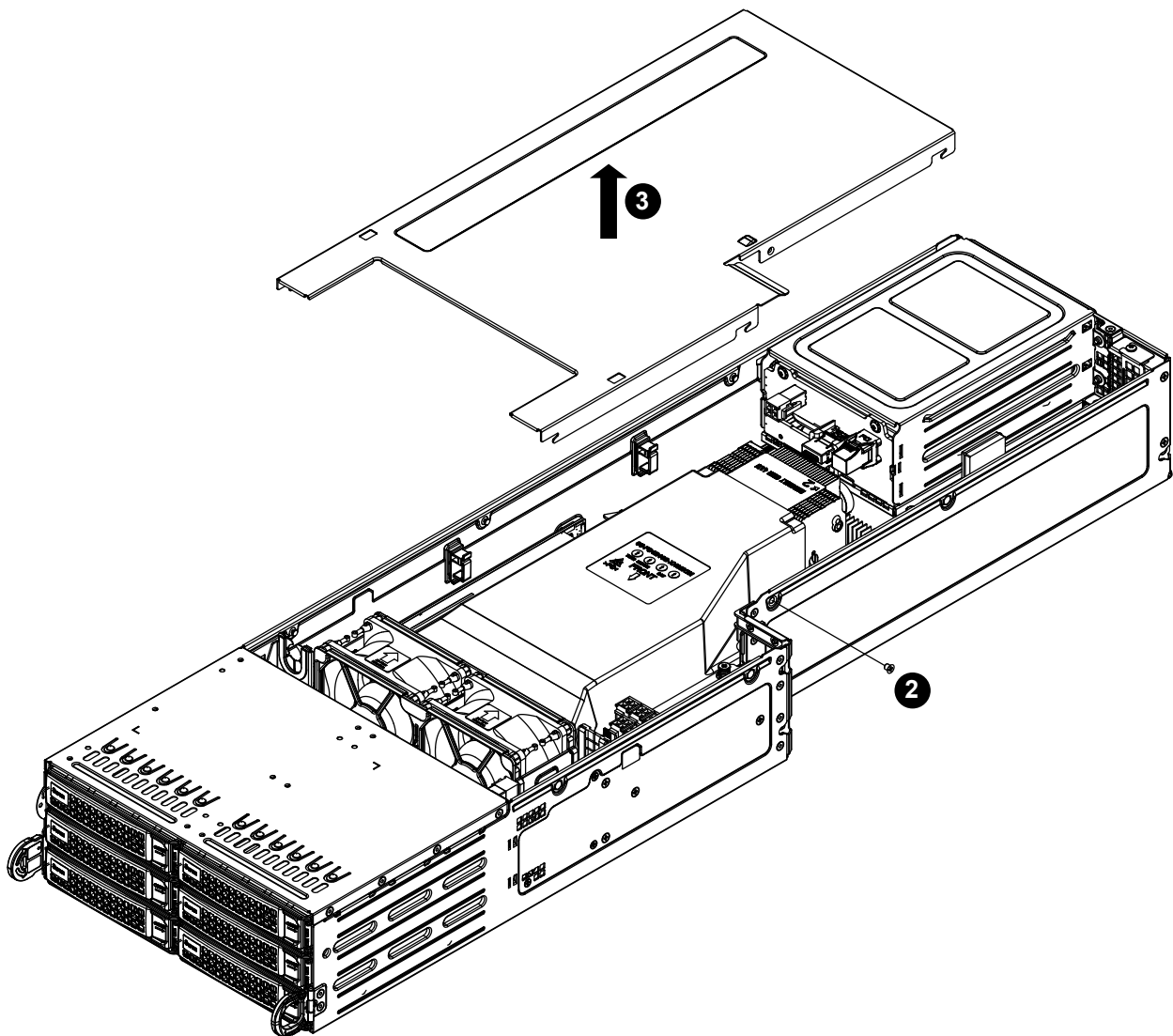

Figure 3-2. Removing the Node Cover

Node Configurations

Overview of the Node

Node configuration for a typical node is shown below in Figure 3-3.

F424AS2 Node Layout

The specifications for the F424AS2 nodes are shown in the table below.

F424AS2 Node Layout Specifications	
Front of Node	Rear of Node
Six (6) 3.5" hot-swappable hard drives	One SIOM Module One low-profile expansion card Two (2) 3.5" hot-swappable hard drives

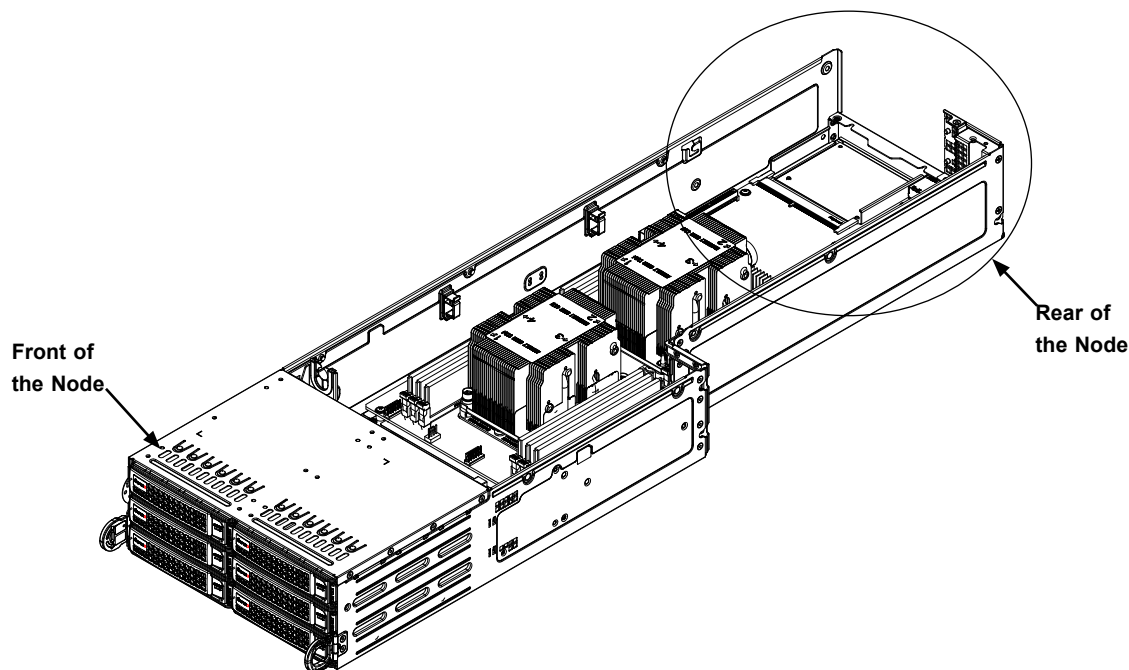

Figure 3-3: Front and Rear of the F424AS2 Serverboard Node
(Your node may differ from the one shown in this illustration)

Associated Hard Drives

The F424AS2 chassis contains four (4) individual motherboards in separate 2U nodes. Each node controls the eight hard drives contained within that node (six in front, two in the rear). Note that if a node is pulled out of the chassis, the hard drives associated with that node will power down as well. Refer to the table below and on the following pages for your specific chassis configuration.

F424AS2	
Node 2 Controls eight 3.5" HDDs, B1-B8	Node 4 Controls eight 3.5" HDDs, D1-D8
Node 1 Controls eight 3.5" HDDs, A1-A8	Node 3 Controls eight 3.5" HDDs, C1-C8

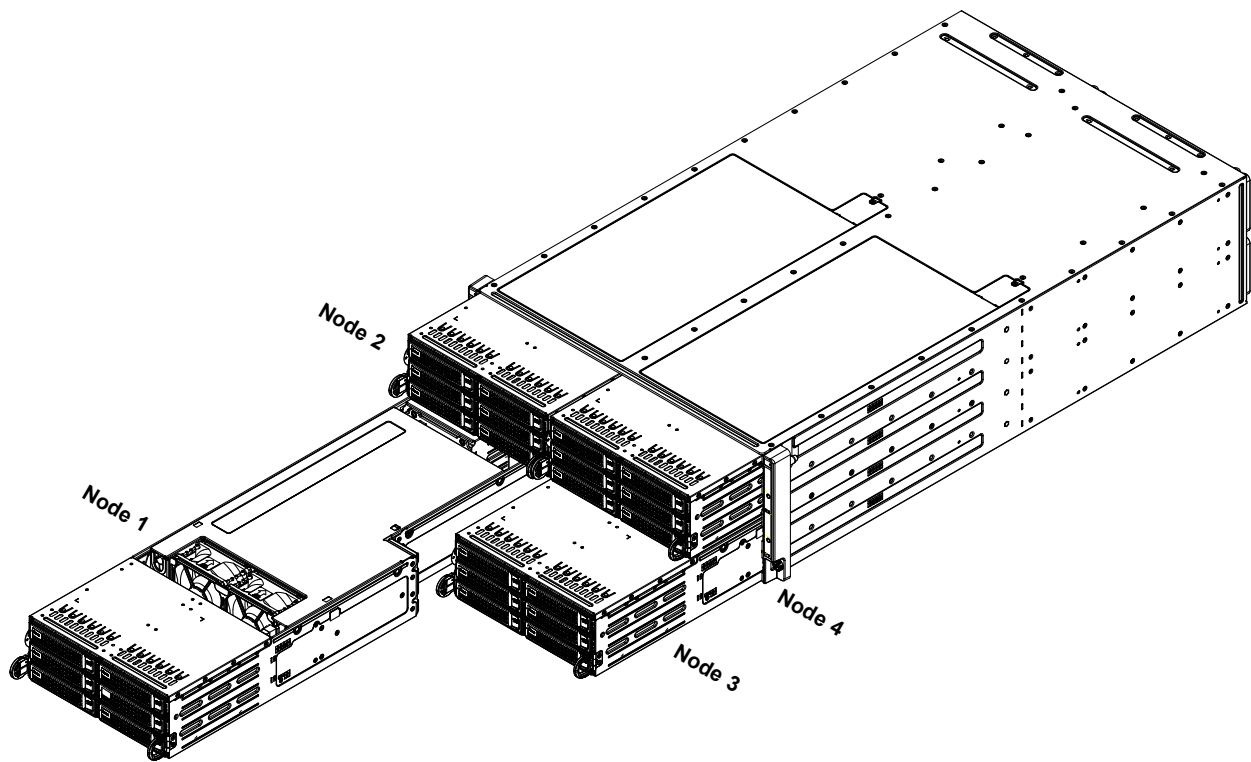

Figure 3-4. Nodes Locations in the Chassis

Installing and Removing 3.5" Hard Drives

These instructions apply to hot-swappable 3.5" hard drives. Hot-swappable hard drives can be removed from the chassis without powering down the server or removing the node from the chassis.

Only enterprise level hard drives are recommended for use in Supermicro chassis.

Removing 3.5" Hard Drive Carriers from the Node

1. Press the release button on the drive carrier. This extends the drive bay handle.
2. Use the handle to pull the drive carrier out of the chassis.

The 3.5" hard drives are mounted in the drive carrier to simplify their installation and removal from the chassis. These carriers also help promote proper airflow for the drive bays.

Warning: Except for short periods of time while swapping hard drives, do not operate the server with the hard drives bays empty.

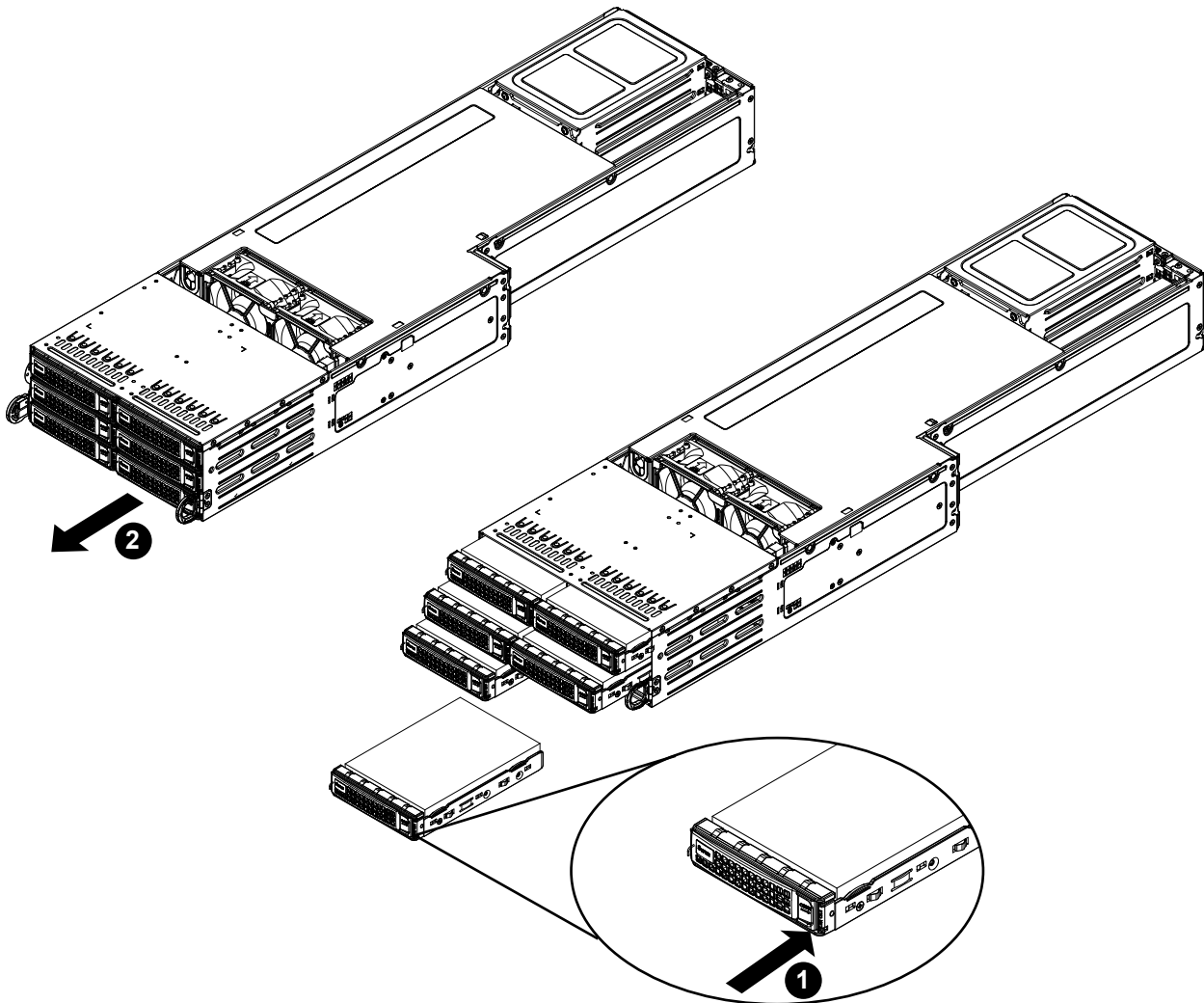

Figure 3-5. Removing a Front Mounted 3.5" Hard Drive Carrier

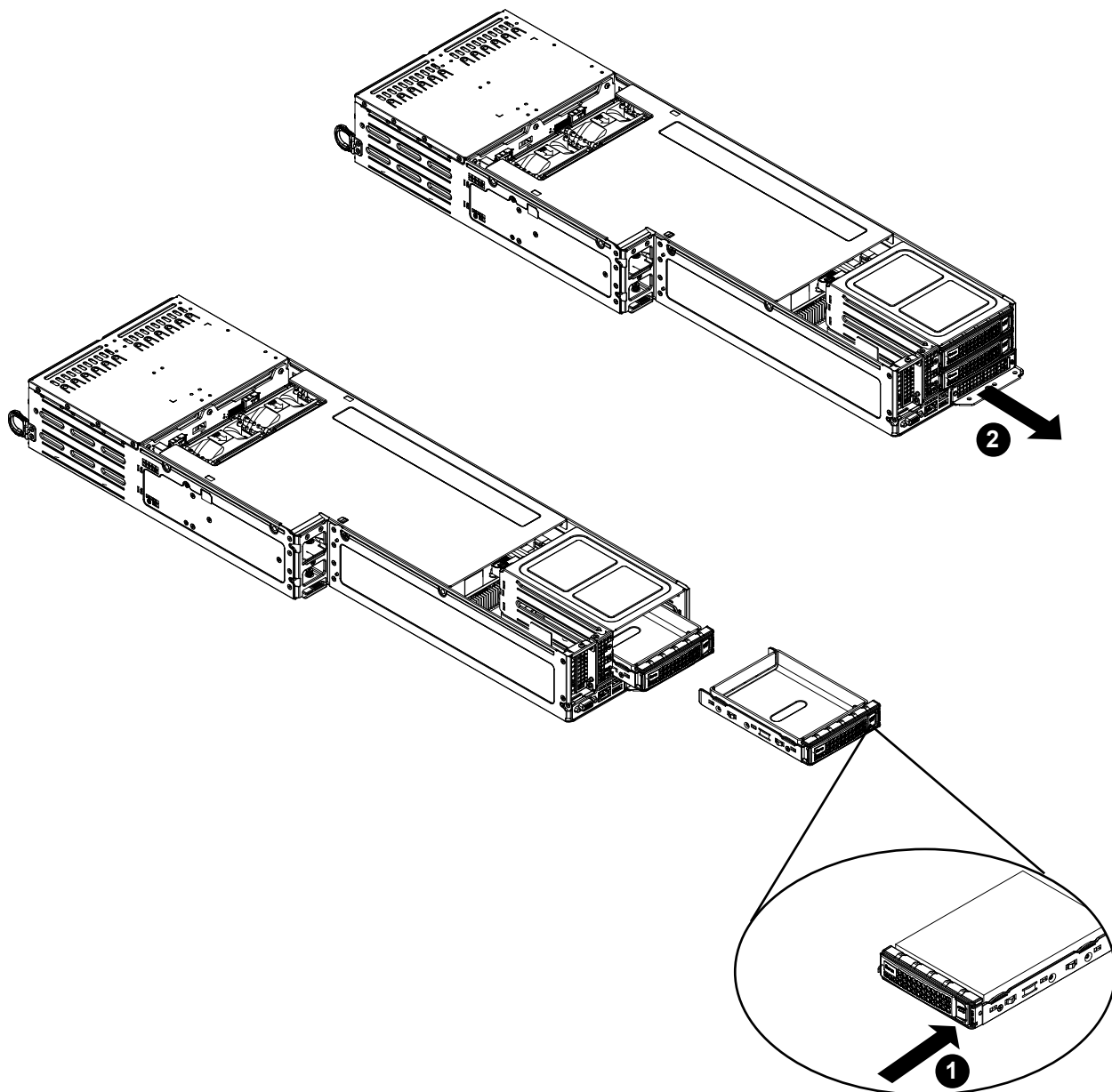

Figure 3-6. Removing a Rear Mounted 3.5" Hard Drive Carrier

Removing the Rear Hard Drive Cage

Removing the Rear Hard Drive Cage

1. Remove the four screws securing the Rear Hard Drive Cage from the Node Chassis.
2. Lift the Rear Hard Drive Cage from the node chassis.

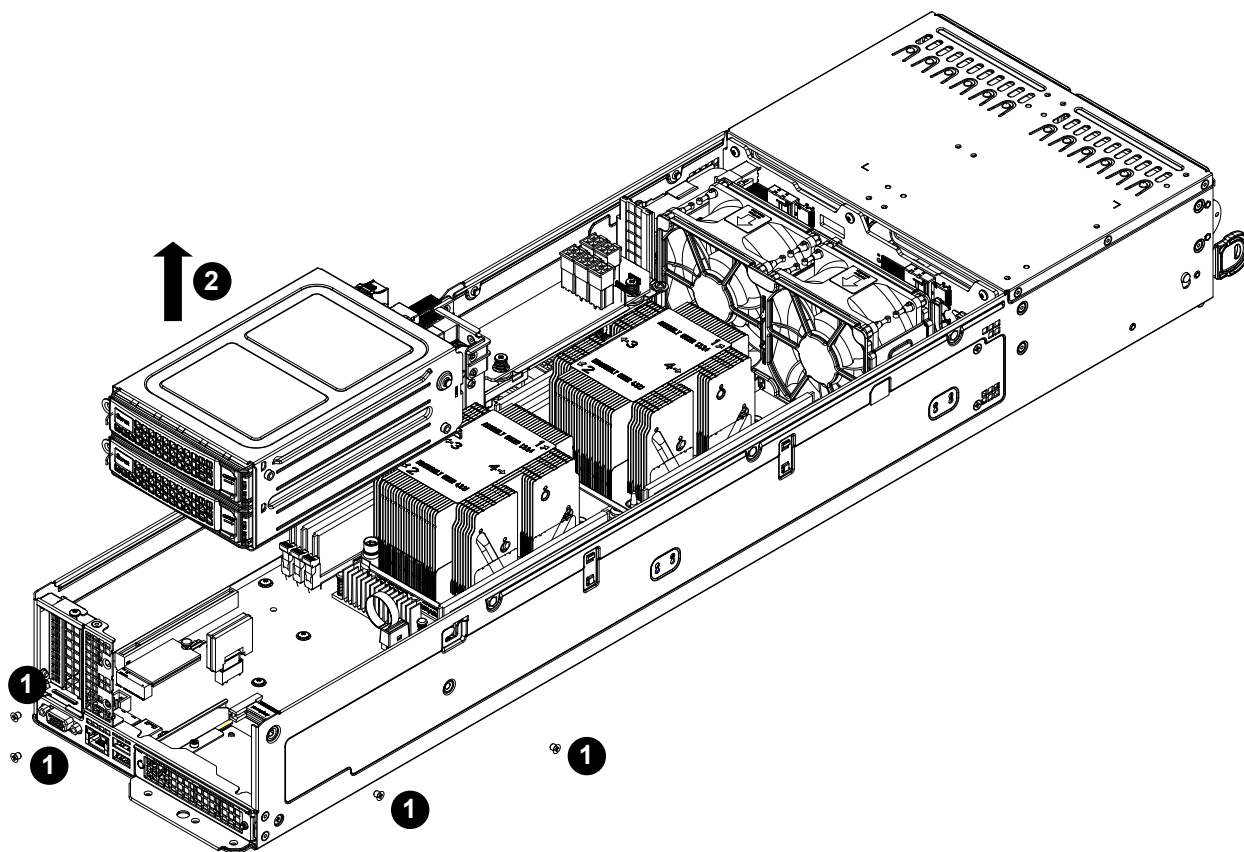
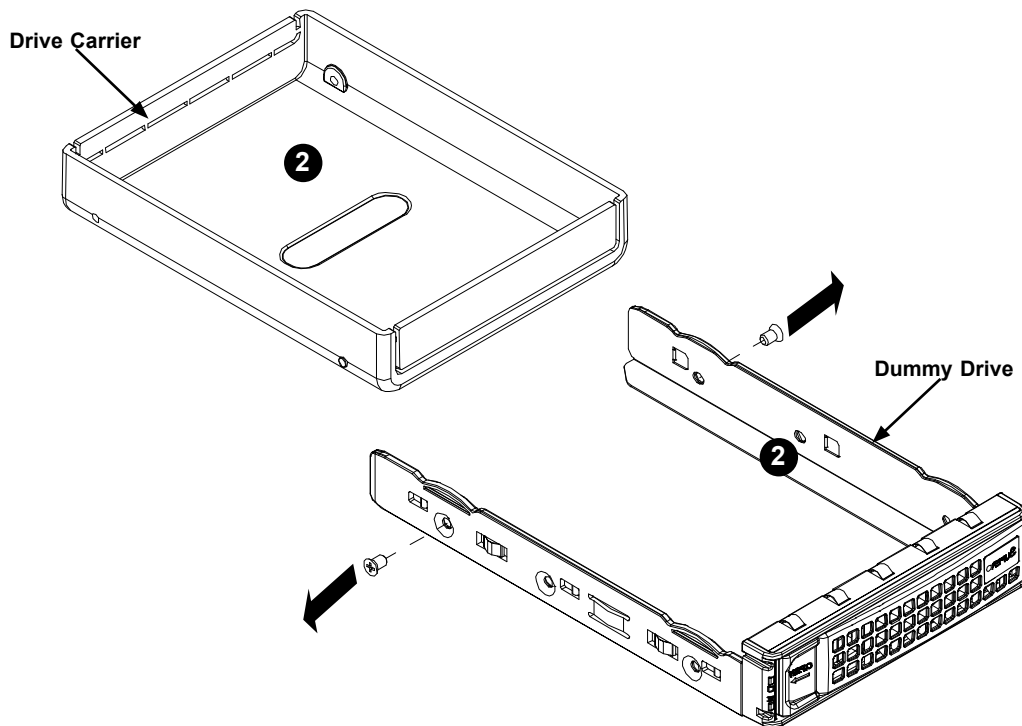

Figure 3-7. Removing the Rear Hard Drive Cage

Removing the Dummy Drive from the 3.5" Drive Carrier

1. Remove the hard drive carrier from the chassis as described in the previous section and lay the drive carrier on a flat surface.
2. Remove the two screws securing the dummy drive to the drive carrier.
3. Lift the dummy drive from the drive carrier.

Caution: Enterprise level hard disk drives are recommended for use in Supermicro chassis and servers. For information on recommended HDDs, visit the Supermicro Web site at <http://www.supermicro.com/products/nfo/files/storage/SAS-CompList.pdf>.

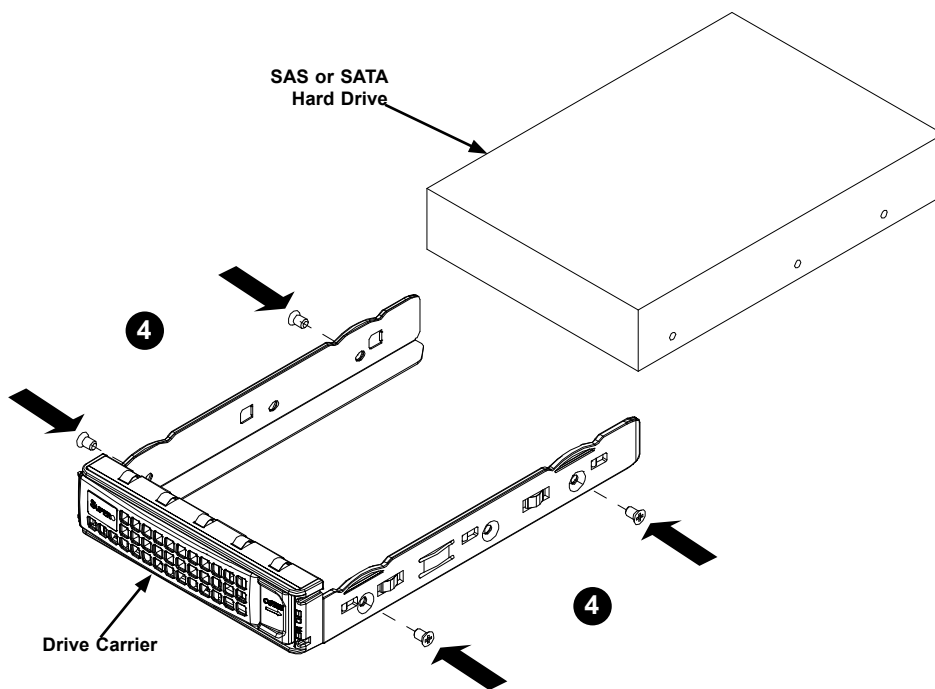

**Figure 3-8: Removing a Dummy Drive from the 3.5" Drive Carrier
(Your drives may differ from the one shown in this illustration)**

Installing a 3.5" Hard Drive into the Drive Carrier

1. Place the hard drive carrier on a flat surface.
2. Insert the hard drive into the carrier with the printed circuit board side facing downward and so that the mounting holes in the drive align with those in the drive carrier.
3. Secure the hard drive to the carrier with the four screws included with the hard drive.
4. Use the open handle of the drive carrier to insert the drive carrier into the open drive bay.
5. Secure the drive carrier into the drive bay by closing the drive carrier handle.

Note that if a node is pulled out of the chassis, the hard drives associated with that node will power down as well. The hard drives are hot-swappable and may be removed from the node without removing the node from the chassis or powering down the system.



**Figure 3-9: Installing a 3.5" Hard Drive into the Drive Carrier
(Your drives may differ from the one shown in this illustration)**

Removing and Installing the Backplane

The F424AS2 chassis backplane is located behind the hard drives and in front of the front system fans in each serverboard node. Although backplane failure rarely occurs, in the event of a backplane failure, follow the instructions below.

Removing the Backplane

Removing the Backplane from the Chassis

1. Using the handles on the front of the serverboard node, pull the node completely out of the chassis and place it on a flat surface.
2. Remove the node cover (see the section Removing the Node Cover for details), and air shroud (see the Installing the Air Shroud section for details).
3. Remove the three screws securing the fan tray to the floor of the node.
4. Remove the three screws securing the backplane to the node (Figure 3-10).
5. Lift the backplane up and out of the chassis.

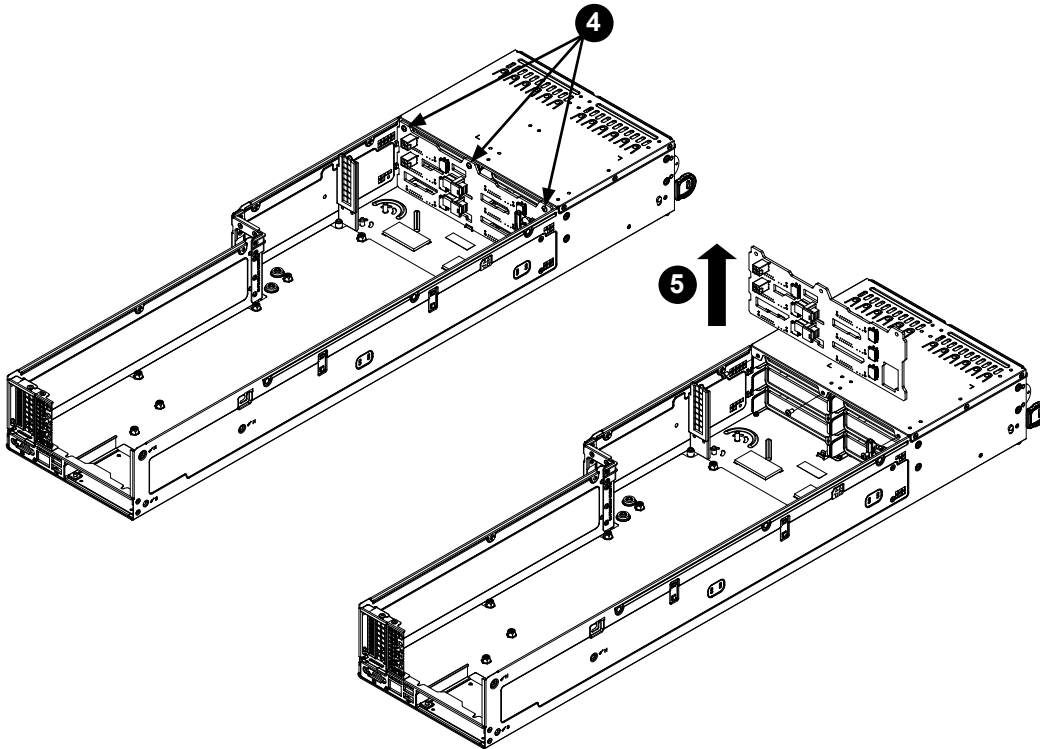

**Figure 3-10: Removing the Backplane from the Node Chassis
(Your node and backplane may differ from the one shown in this illustration)**

Installing the Backplane

Installing the Backplane into the Chassis

1. Ensure that all of the hard drive carriers have been removed from the bays in the front of the node (see the section Installing and Removing Hard Drives for details).
2. Ease the backplane forward, against the front of the chassis.
3. Align the mounting holes in the backplane with the holes in the chassis. Replace the three screws at the top of the backplane
4. Reconnect all cables and return the hard drive trays to their bays in the front of the serverboard node.

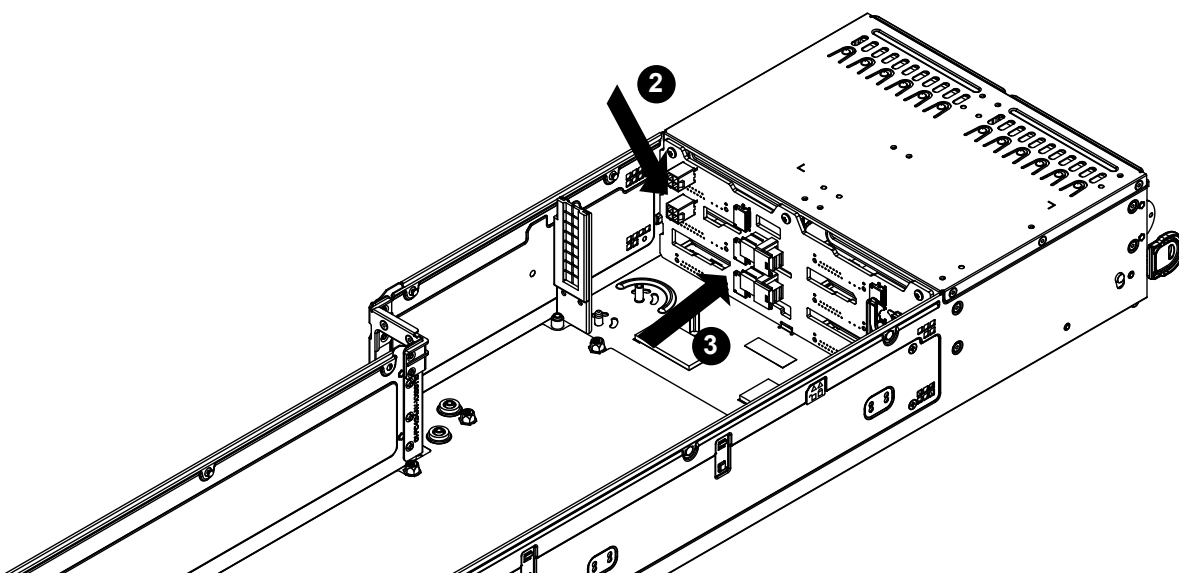

Figure 3-11: Installing the Backplane
(Your node and backplane may differ from the one shown in this illustration)

Removing the Rear Hard Drive Cage Backplane

Removing the Rear Hard Drive Cage Backplane

1. Remove the two screws securing the Rear Hard Drive Cage Backplane to the Rear Hard Drive Cage.
2. Lift the backplane off of the Rear Hard Drive Cage.

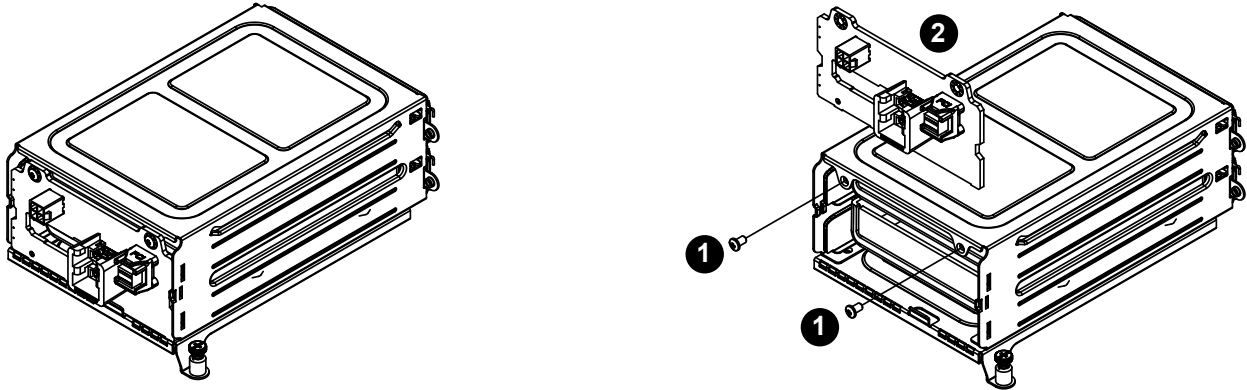

Figure 3-12: Removing the Backplane from the Rear Hard Drive Cage
(Your node and backplane may differ from the one shown in this illustration)

Installing the Serverboard

Compatible Motherboards

For the most up-to-date information on compatible motherboards and other parts, visit the Supermicro Web site at www.supermicro.com.

Permanent and Optional Standoffs

Standoffs prevent short circuits by creating space between the serverboard and the floor of the node. The F424AS2 chassis includes permanent standoffs in locations used by most motherboards. These standoffs use the rounded Phillips head screws included in the chassis accessories packaging.

Some motherboards require additional screws for heatsinks, general components and/or non-standard security. Optional standoffs are used for these motherboards.

To use an optional standoff, compare the mounting holes in the serverboard with those in the floor of the serverboard node. Then place a screw through the bottom the node and secure the screw with a hexagonal nut (rounded side up).

Depending upon the configuration of the serverboard being used, it is also possible that some of the optional standoffs which are pre-installed in the chassis, may need to be removed. Add or remove standoffs as needed.

Installing the Serverboard

1. Review the documentation that came with your serverboard. Become familiar with component placement, requirements, cautions, and cable connections.
2. Power down the system and remove the power cord from the rear of the power supply. Remove the node from the chassis and place the node on a flat, stable surface. Then remove the cover from the node.
3. Compare the holes in the serverboard with those in the floor of the node, then add or remove standoffs as needed.
4. Secure the serverboard to the floor of the node tray using the rounded, Phillips head screws included for this purpose. Do not exceed eight pounds of torque when tightening down the serverboard.
5. Install the expansion card associated with the serverboard if the chassis is a hot-swappable version. Refer to the next section for instructions on installing the expansion card
6. Secure the CPU(s), heatsinks, and other components to the serverboard as described in the serverboard documentation.

7. Connect the cables between the serverboard, backplane, chassis, front panel, and power supply, as needed. The fans may be temporarily removed to allow access to the backplane ports.
8. Replace the expansion card bracket and secure the bracket with a screw.
9. Repeat steps 3 - 5 for the remaining nodes.

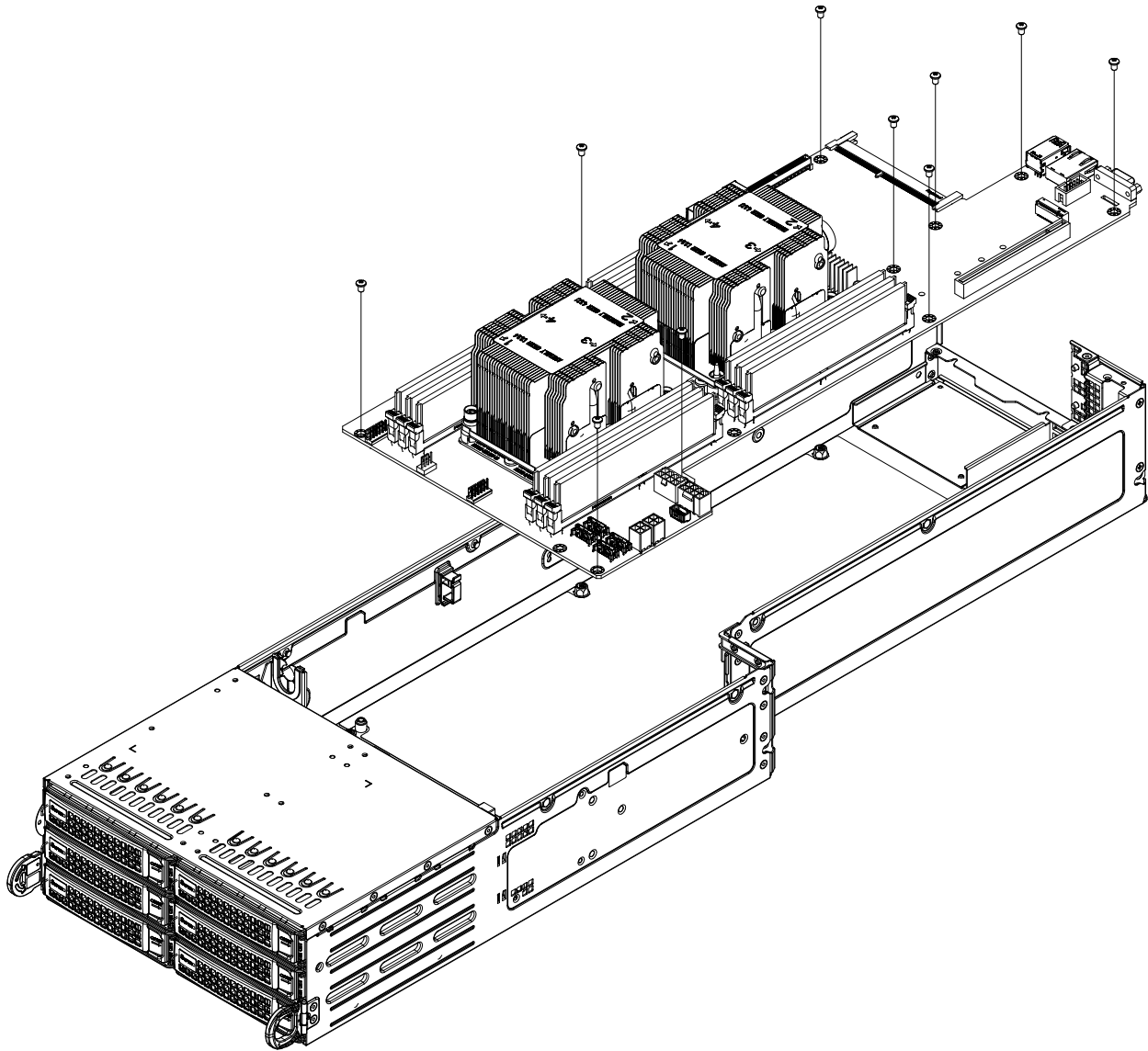

**Figure 3-13: Installing the Serverboard in the Serverboard Node Tray
(Your node and serverboard may differ from the one shown in this illustration)**

Power Adapter Card Replacement

Each of the serverboard nodes for the server includes a power adapter card, which connects it to the chassis. In the unlikely event of a failure of the power adapter card, replacement is simple and requires only a Phillips head screwdriver.

Changing the Power Adapter Card

1. Remove the node from the chassis and place the node on a flat, stable surface. Then remove the cover from the node.
2. Remove the four screws securing the power adapter card to the mounting bracket.
3. Disconnect all cables.
4. Carefully lift the power adapter card up and out of the node. Set the screws aside for later use.
5. Install the replacement power adapter card into the same position on the mounting bracket, aligning the mounting holes of the board with those in the node.
6. Secure the board with the four screws previously set aside. Do not exceed eight pound of torque when tightening the power adapter board.
7. Reconnect all cables.

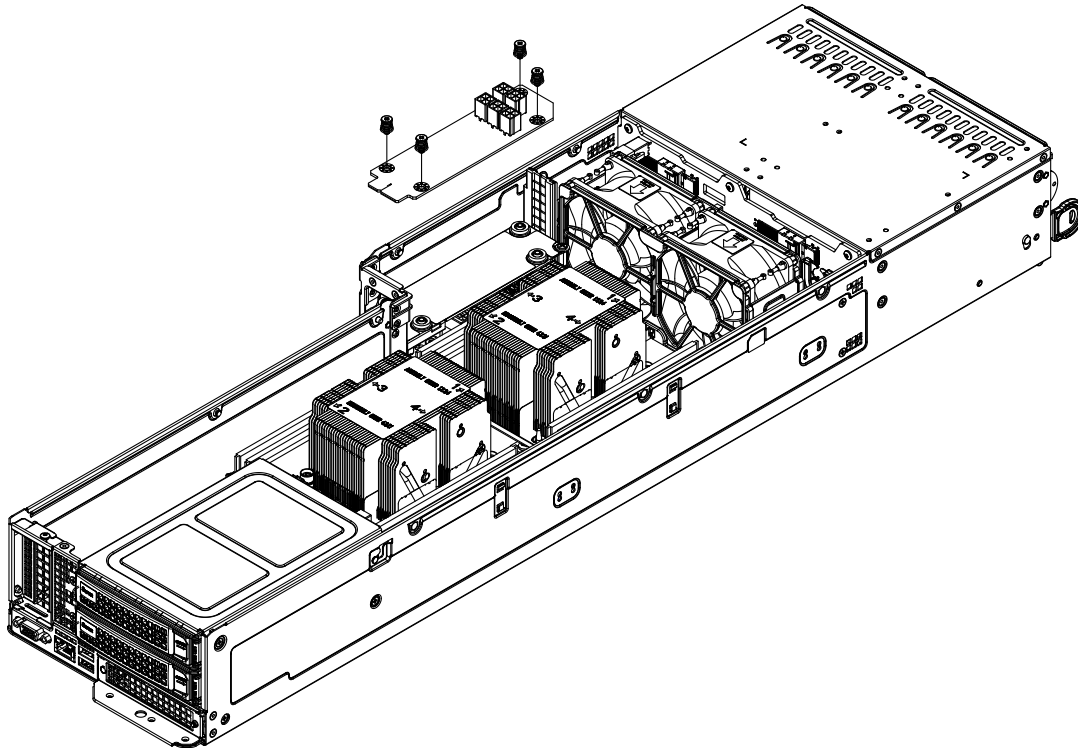

Figure 3-14: Installing the Adapter Card
(Your node and backplane may differ from the one shown in this illustration)

Installing Expansion Cards

F424AS2 PCI-E Slot Configurations

Some F424AS2 chassis models support one or more expansion cards in each node, Refer to the tables below to determine the PCI-E slot configuration for your particular chassis.

F424AS2	
Front of Node	Rear of Node
Six 3.5" hot-swappable hard drives	One SIOM Module Bay One low-profile expansion card Two 3.5" hot-swappable hard drives

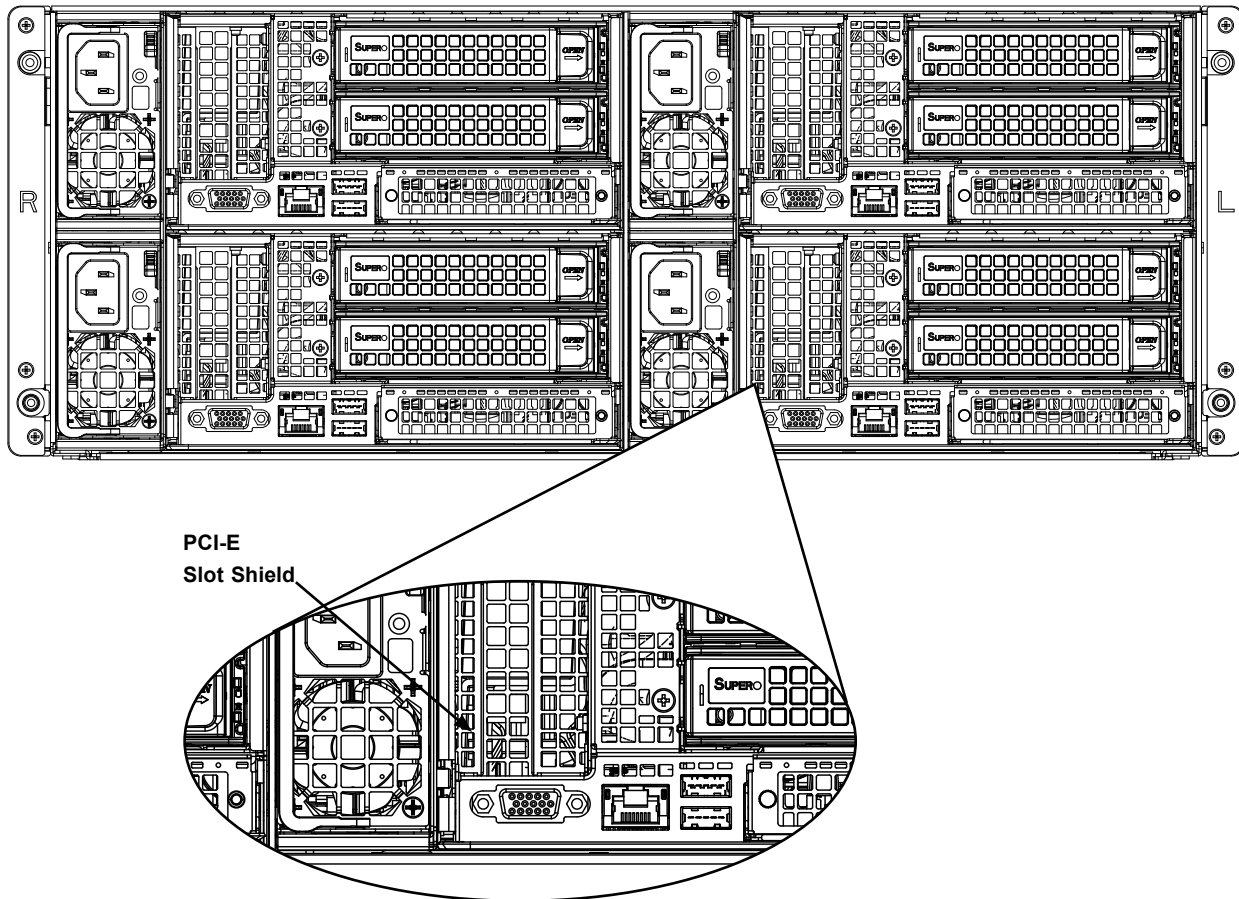

Figure 3-15: Rear I/O Shield Configuration

Installing the PCI-E Slot Bracket Assembly Into the Node

Installing the PCI-E Slot Bracket Assembly

1. Remove the one screw securing the PCI-E Slot Shield.
2. Make sure the expansion card is low profile. Plug the expansion card into the PCI-E slot on the serverboard..
3. Secure the expansion card into the rear window with the same screw securing the PCI-E slot shield.

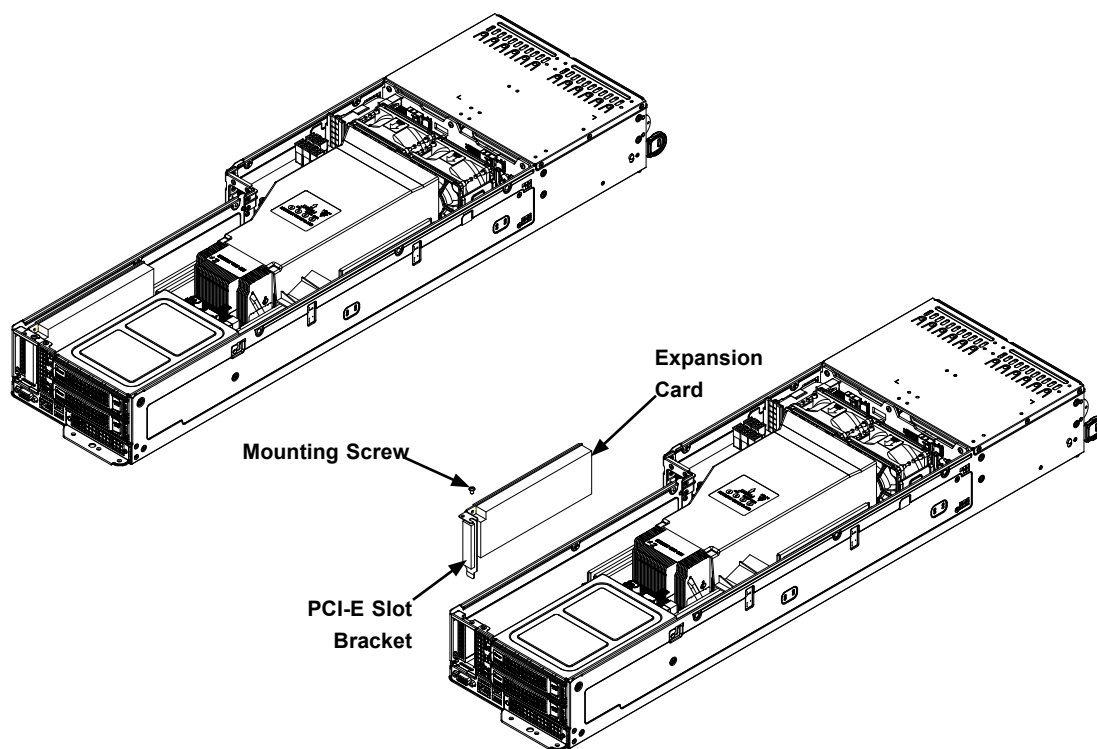

Figure 3-16: Installing the PCI-E Slot Bracket Assembly

Installing a SIOM Module

Each node in the system has one front mounted SIOM module, which adds various I/O ports to the node, depending upon the module selected. To install a module, use the procedure below.

Installing a SIOM module

1. Remove the SIOM bracket by unscrewing two screws, one on the side of the node tray, one underneath.
2. Remove one screw securing the SIOM Slot shield.
3. Install any SIOM into the bracket, and securing the SIOM by tightening the two built-in screws on the SIOM.
4. Install the assembled SIOM bracket into the node tray, and tightening the two screws used in step 1.

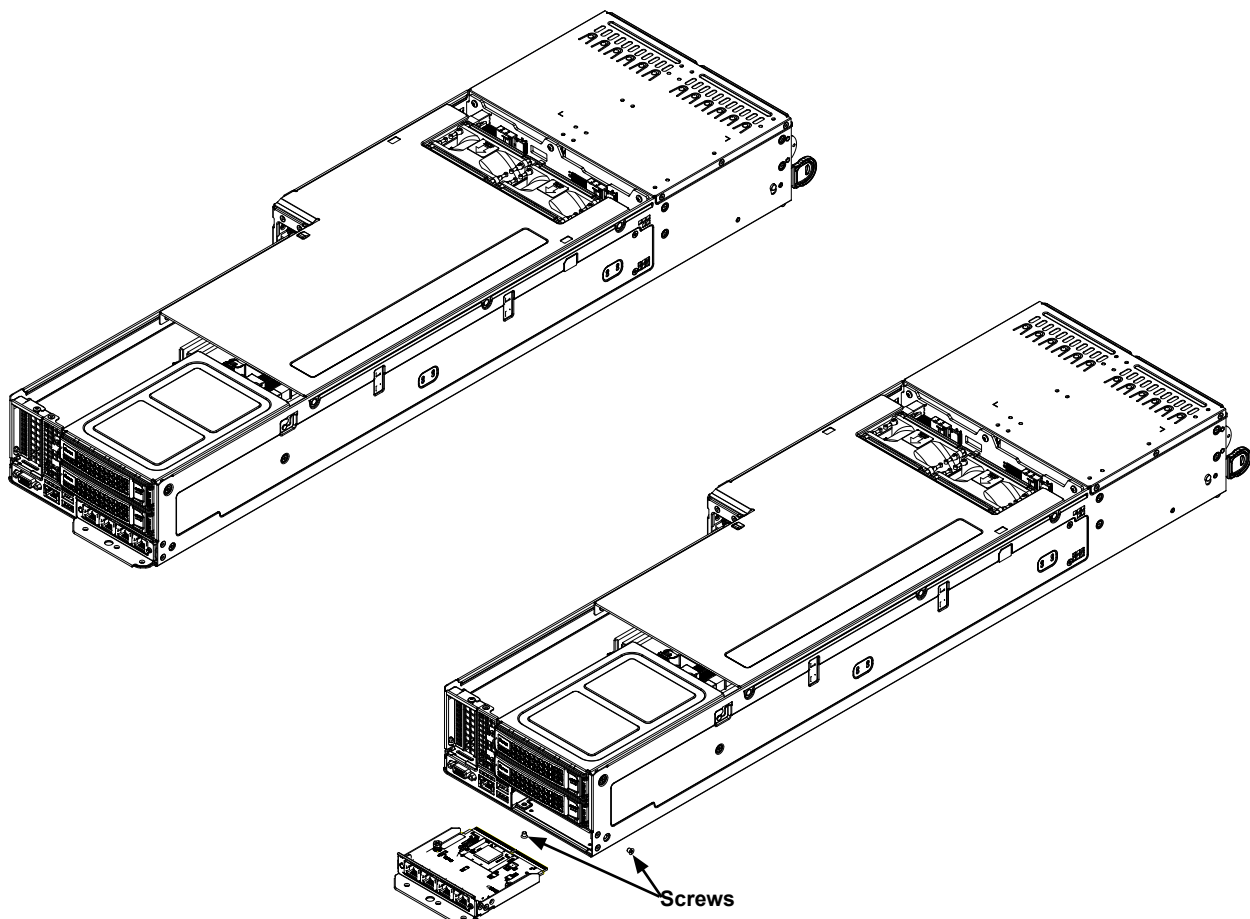

Figure 3-17: Installing the SIOM

Installing Air Shrouds

Air shrouds concentrate airflow to maximize fan efficiency. The F424AS2 chassis requires an air shroud in each node.

Installing an Air Shroud

1. Remove the node from the chassis and remove the cover from the node.
2. Make sure that the serverboard and all components are properly installed in each node.
3. Place the air shroud over the serverboard, as illustrated below. The air shroud sits behind the system fans and goes over the top of the serverboard and its components. It uses one screw to secure it in place.
4. Repeat the procedure for the remaining three nodes.

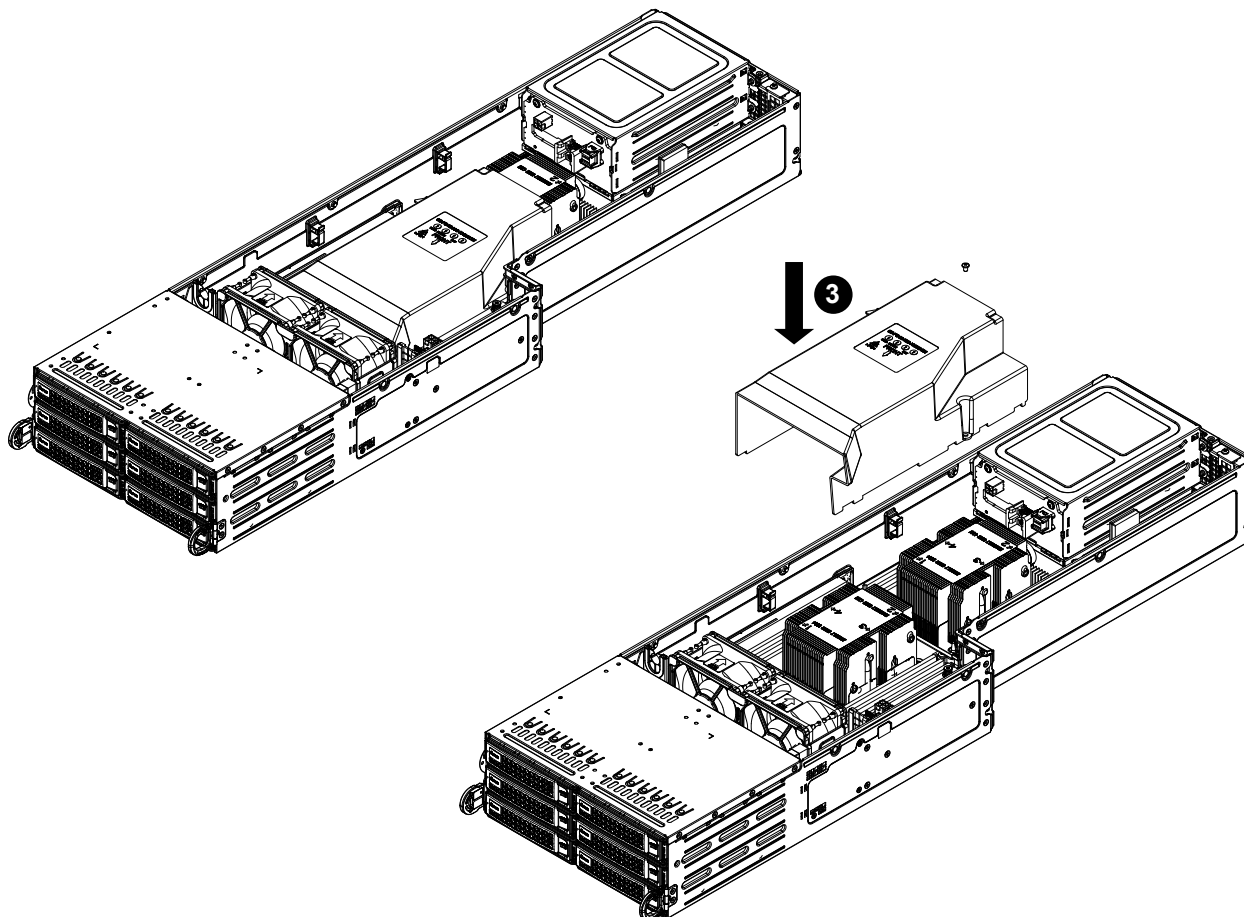

Figure 3-18: Installing the Air Shroud

Removing and Installing System Fans

System fans provide cooling for each node. Front I/O nodes have rear external fans and rear I/O nodes have front internal fans. These fans circulate air through the node as a means of lowering the internal temperature. The F424AS2 system fans are easily removed from the fan tray. There is no need to uninstall any other parts when replacing fans, and only a Phillips screwdriver is required for installation.

Replacing a Front Internal System Fan

1. Determine which serverboard node contains the failed fan,.Remove the node from the chassis as described in Section 3-2 and place the node on a flat, stable surface. Remove the cover from the node as described in Section 3-2.
2. Remove the one screw securing the air shroud and lift the air shroud up and out of the node.
3. Disconnect all fan cables from the motherboard.
4. Remove the screws securing the fan housing to the floor of the node and set them aside for later use.
5. Lift the fan housing up and out of the chassis.
6. Simultaneously squeeze both sets of release tabs on each side of the fan housing. This will release the cover plate of the housing which holds the fans inside the housing. Either the front or rear cover plate may be released.
7. Pull the cover plate off the fan housing.
8. Remove the four rubber spacers from the housing.
9. Pull out the failed fan and replace it with a new one.
10. Reinstall the rubber spacers in the fan housing.
11. Reinstall the face cover of the fan housing, by aligning the release tabs with their slots in the housing and gently pushing the face cover onto the housing until it clicks into the locked position.
12. Reconnect the cabling to both fans.
13. Reinstall the fan housing in the serverboard node and secure it to the floor of the node with the four screws which were previously set aside.

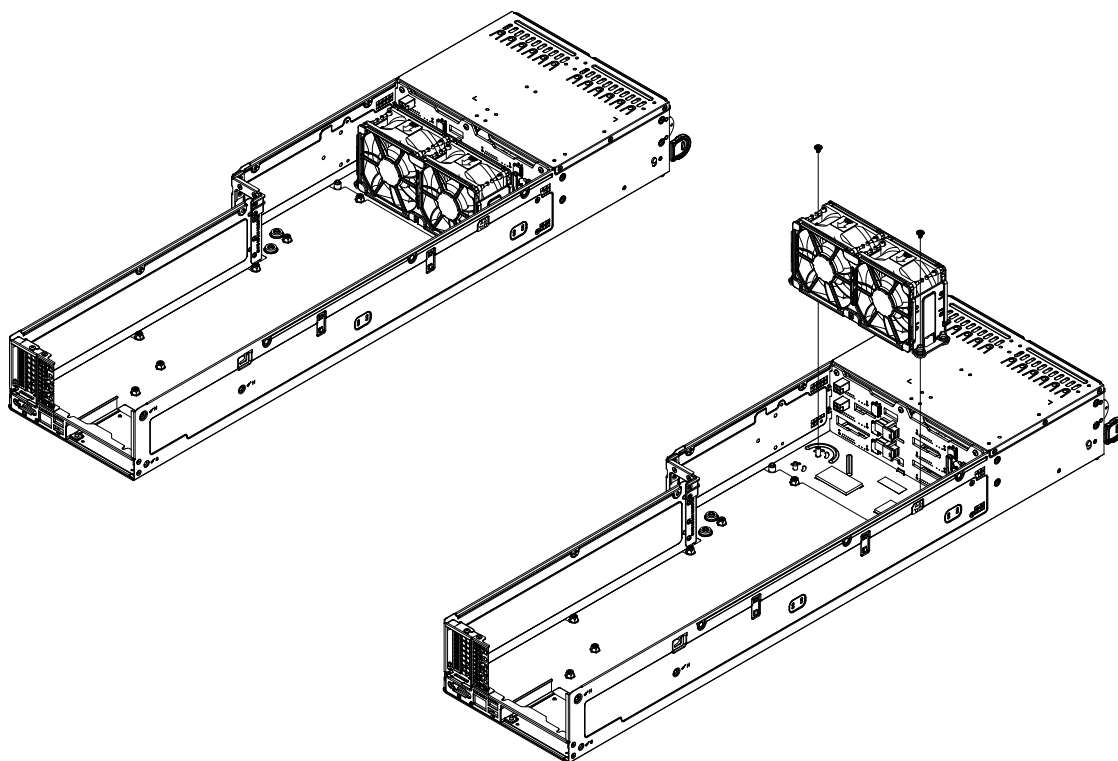

Figure 3-19: Removing the Fan Tray

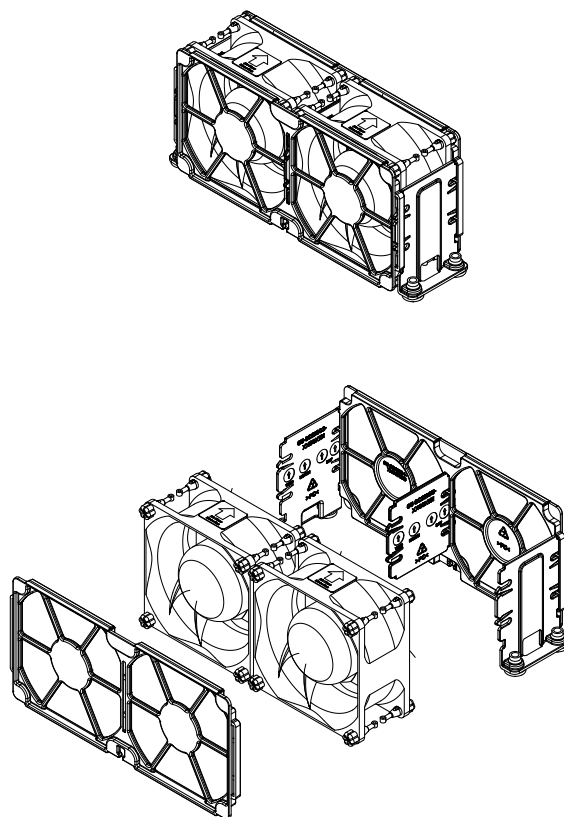

Figure 3-20: Removing the Fan from the Fan Tray

Replacing the Power Supplies

The F424AS2 chassis includes a 1200 Watt power supply. This power supply is auto-switching capable. This enables it to automatically sense and operate at a 100v to 240v input voltage. An amber light will be illuminated on the power supply when the power is off. An illuminated green light indicates that the power supply is operating.

Power Supply Replacement

The F424AS2 chassis utilizes two redundant power supplies (four in total). In the unlikely event that the power supply unit needs to be replaced, one power supply can be removed, without powering down the system. Replacement units can be ordered directly from Supermicro (See the contact information in the Preface of this manual).

Changing the Power Supply

1. Press the release tab on the back of the power supply and pull the power supply out using the handle provided.
2. Push the replacement power supply module into the power bay until it clicks into the locked position.
3. Plug the AC power cord back into the module and return the node to its bay in the chassis.

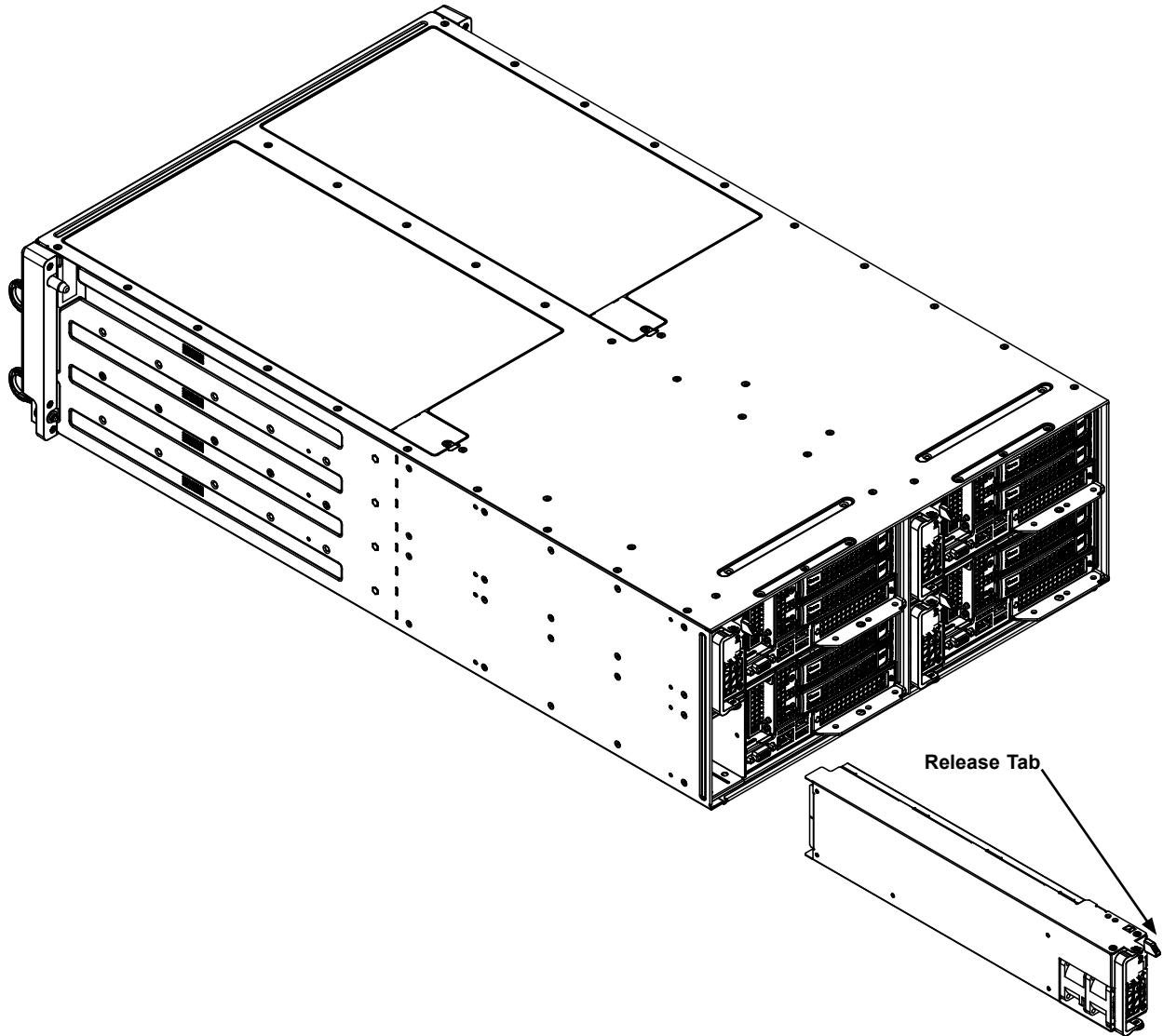

Figure 3-21: Changing the F424AS2 Chassis Power Supplies

3.3 Motherboard Components

Processor and Heatsink Installation

Warning: When handling the processor package, avoid placing direct pressure on the label area of the fan. Also, improper CPU installation or socket misalignment can cause serious damage to the CPU or the motherboard that will require RMA repairs. Please read and follow all instructions thoroughly before installing your CPU and heatsink.

Notes:

- Always connect the power cord last, and always remove it before adding, removing or changing any hardware components. Make sure that you install the processor into the CPU socket before you install the CPU heatsink.
- If you buy a CPU separately, make sure that you use an Intel-certified multi-directional heatsink only.
- Make sure to install the motherboard into the chassis before you install the CPU heatsink.
- When receiving a motherboard without a processor pre-installed, make sure that the plastic CPU socket cap is in place and none of the socket pins are bent; otherwise, contact your retailer immediately.
- Refer to the Supermicro website for updates on CPU support.

The Processor

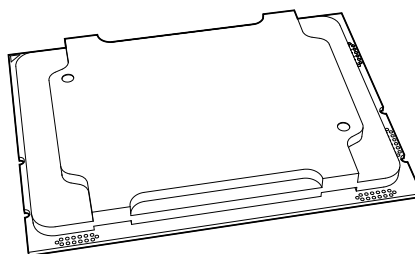

(The Intel Xeon 81xx/61xx/51xx/41xx/31xx series Processor)

Note: All graphics, drawings and pictures shown in this manual are for illustration only. The components that came with your machine may or may not look exactly the same as those shown in this manual.

Overview of the Processor Socket Assembly

The processor socket assembly contains 1) the Intel Xeon 81xx/61xx/51xx/41xx/31xx series processor 2) CPU/heatsink carrier, 3) dust cover, and 4) CPU socket.

1. The Intel Xeon 81xx/61xx/51xx/41xx/31xx series Processor

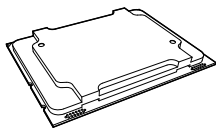

2. CPU/Heatsink Carrier

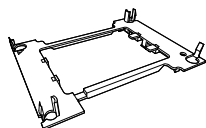

3. Dust Cover

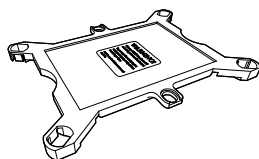

4. CPU Socket

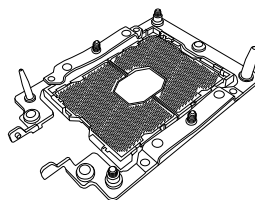

CPU Socket Assembly

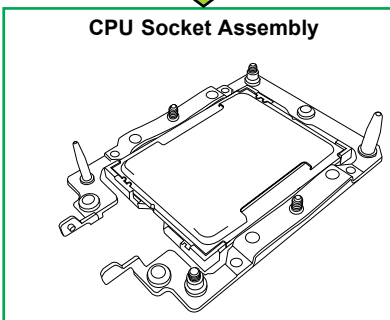

Note: Be sure to cover the CPU socket with the dust cover when the CPU is not installed.

Overview of the Processor Heatsink Module

The processor heatsink module (PHM) contains 1) a passive heatsink, 2) a CPU/heatsink carrier, and 3) The Intel Xeon 81xx/61xx/51xx/41xx/31xx series processor.

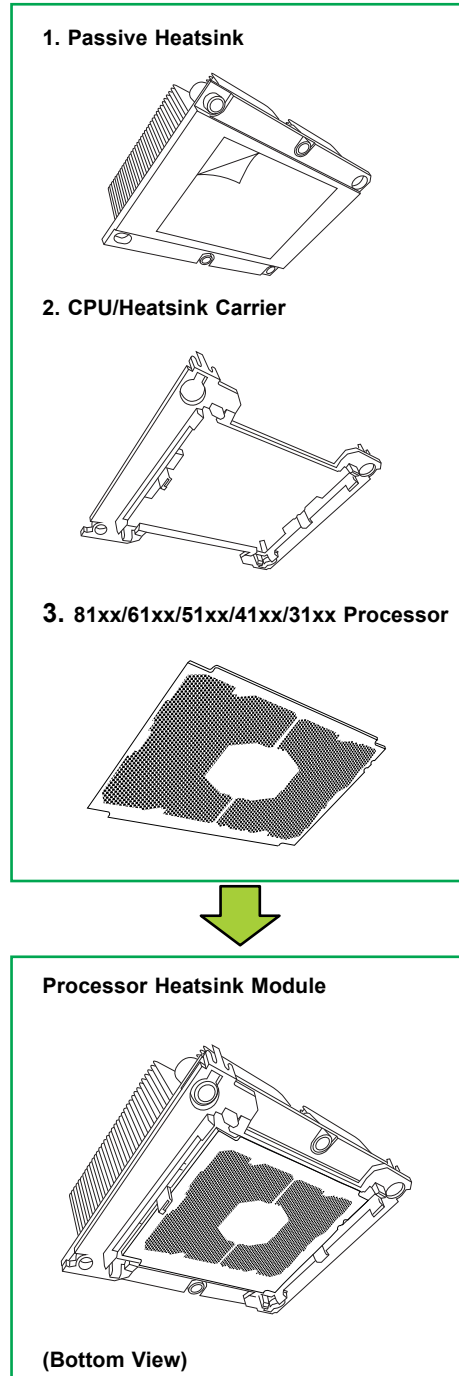

Preparing the CPU Socket for Installation

This motherboard comes with the CPU socket pre-assembled in the factory. The CPU socket contains 1) a dust cover, 2) a socket bracket, 3) the CPU (LGA3647) socket, and 4) a back plate. These components are pre-installed on the motherboard before shipping.

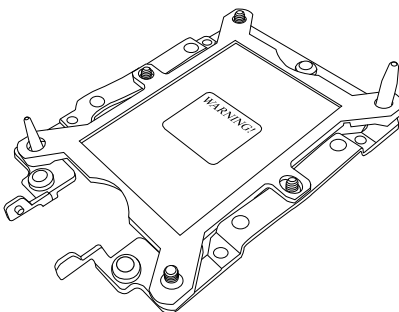

Processor Socket Assembly

Removing the Dust Cover from the CPU Socket

Remove the dust cover from the CPU socket, exposing the LGA3647 socket and socket pins as shown on the illustration below.

Note: Do not touch the socket pins to avoid damaging them, causing the CPU to malfunction.

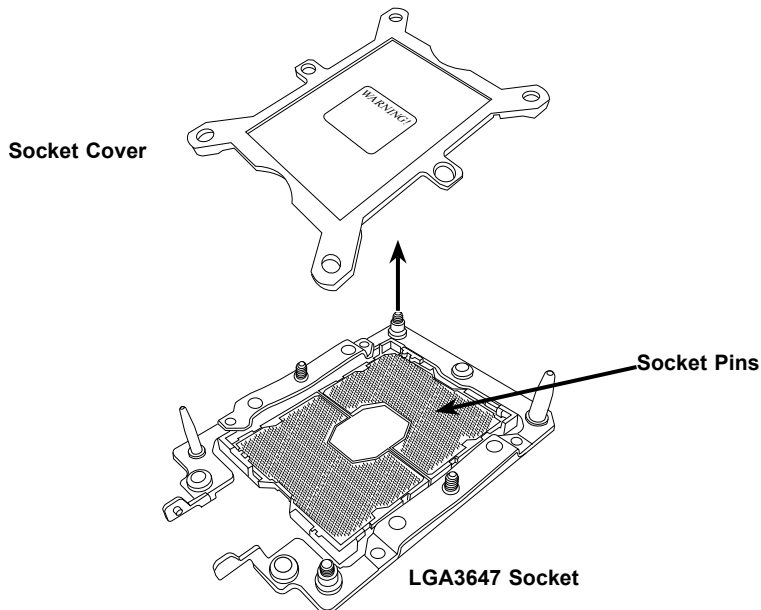

Attaching the Processor to the CPU/Heatsink Carrier

To properly install the CPU onto the CPU/heatsink carrier, please follow the steps below.

Installing the CPU onto the CPU/heatsink

1. Locate Pin 1 (Notch A), Notch B, and Notch C on the CPU and locate Pin 1 (Notch A), Notch B, and Notch C on the CPU/heatsink carrier.
2. Align Pin 1 (Notch A), Notch B, and Notch C on the CPU with the corresponding notches on the carrier. Once they are aligned, carefully insert the CPU into the carrier until you hear a click. Once the CPU is properly mounted onto the carrier, the CPU/carrier assembly is made.

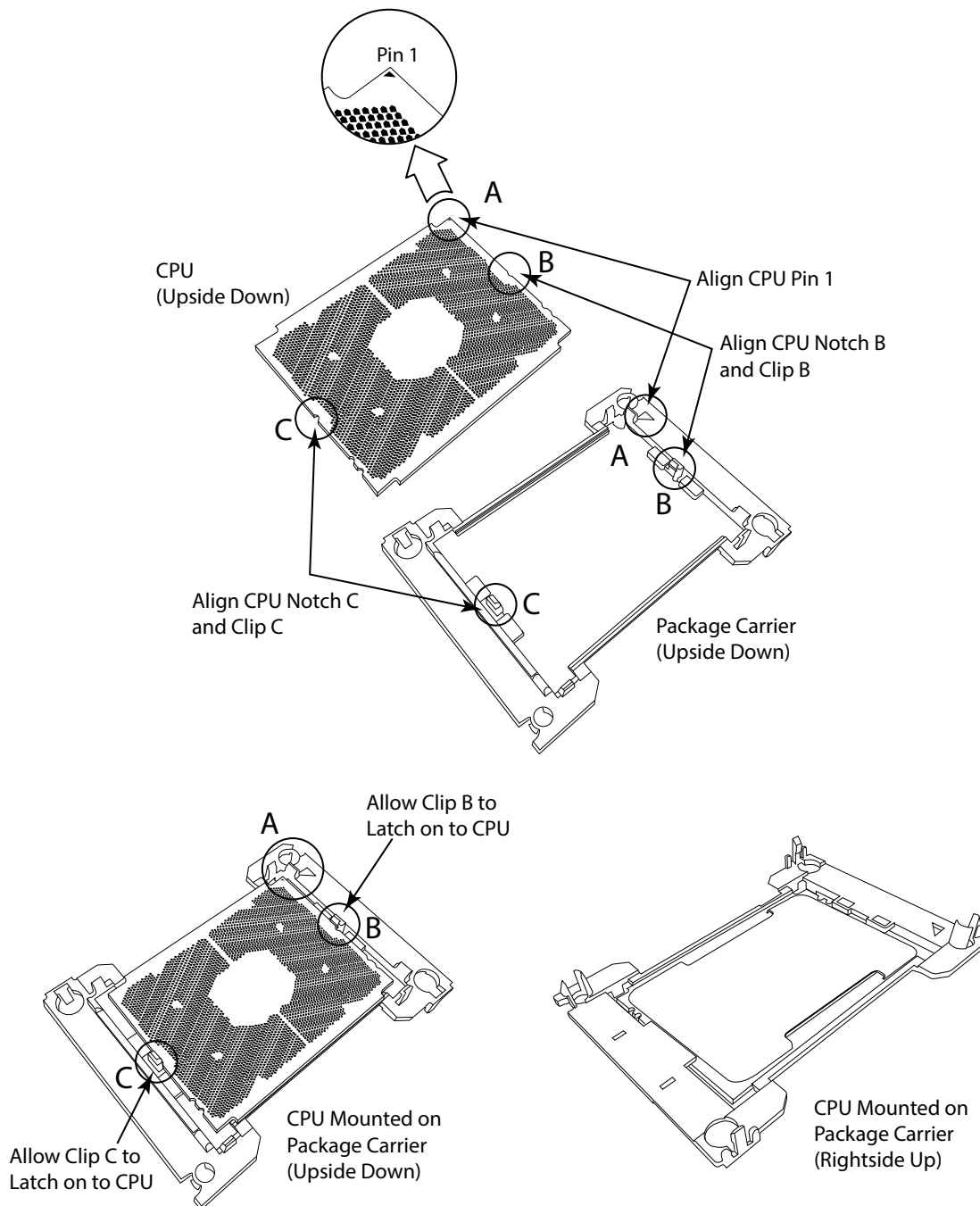

Attaching the CPU/Carrier Assembly to the Passive Heatsink to Form the Processor Heatsink Module (PHM)

After you have made a CPU/carrier assembly, please follow the steps below to mount the assembly onto the heatsink to create the Processor Heatsink Module (PHM).

1. Place the heatsink upside down with the thermal grease facing up. Locate two larger mounting holes (A, B) at the diagonal corners of the heatsink, and two smaller mounting holes (C, D) on the heatsink.
2. Hold the CPU/carrier at the center edge, and turn it upside down with the CPU pins facing up. Locate the two larger holes (1, 2) at the diagonal corners of the carrier and the smaller holes of the same size (3, 4) on the carrier. Please note the mounting clips located next to every mounting hole on the carrier.
3. Align the larger holes (1, 2) on the carrier against the larger mounting holes (A, B) on the heatsink and smaller holes (3, 4) on the carrier against the smaller mounting holes (C, D) on the heatsink. Insert the mounting clips next to the larger hole on the carrier into the larger mounting hole on the heatsink (1 → A, 2 → B) and snap the mounting clips next to the smaller holes on the carrier onto the edges of the heatsink next to the smaller holes (3 → C, 4 → D) making sure that the mounting clips snap into place, and that the CPU/carrier assembly is properly mounted onto the heatsink. By mounting the CPU/carrier assembly to the heatsink, the Processor Heatsink Module (PHM) is assembled.

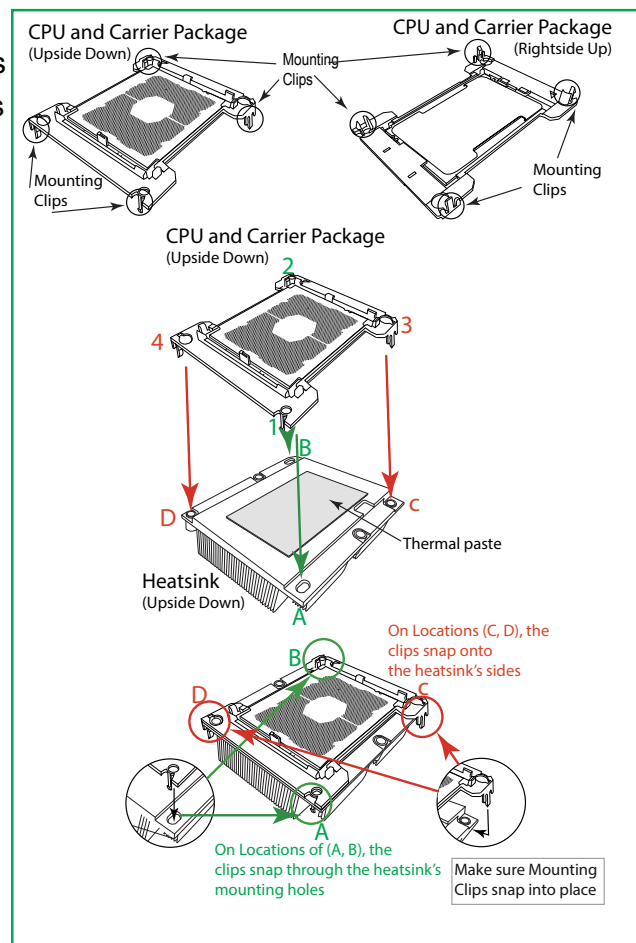

Installing the Processor Heatsink Module (PHM)

1. Once you have assembled the processor heatsink module (PHM) by following the instructions listed on the previous page, align the processor heatsink module with the CPU socket on the motherboard.
2. Align the large hole on the heatsink against the large notch on the CPU socket, the small hole on the heatsink against the small notch on the socket. Carefully insert the PHM into the socket, making sure that the large and small notches fit through the corresponding mounting holes on the socket. The PHM will only fit one way. If it does not fit correctly, remove it and try again.
3. Using a T30-size star driver bit, tighten four screws into the mounting holes on the socket to securely install the PHM into the motherboard, starting with the mounting hole marked #1 (in the sequence of 1, 2, 3, and 4).

Note: Do not use excessive force when tightening the screws to avoid damaging the CPU and the socket.

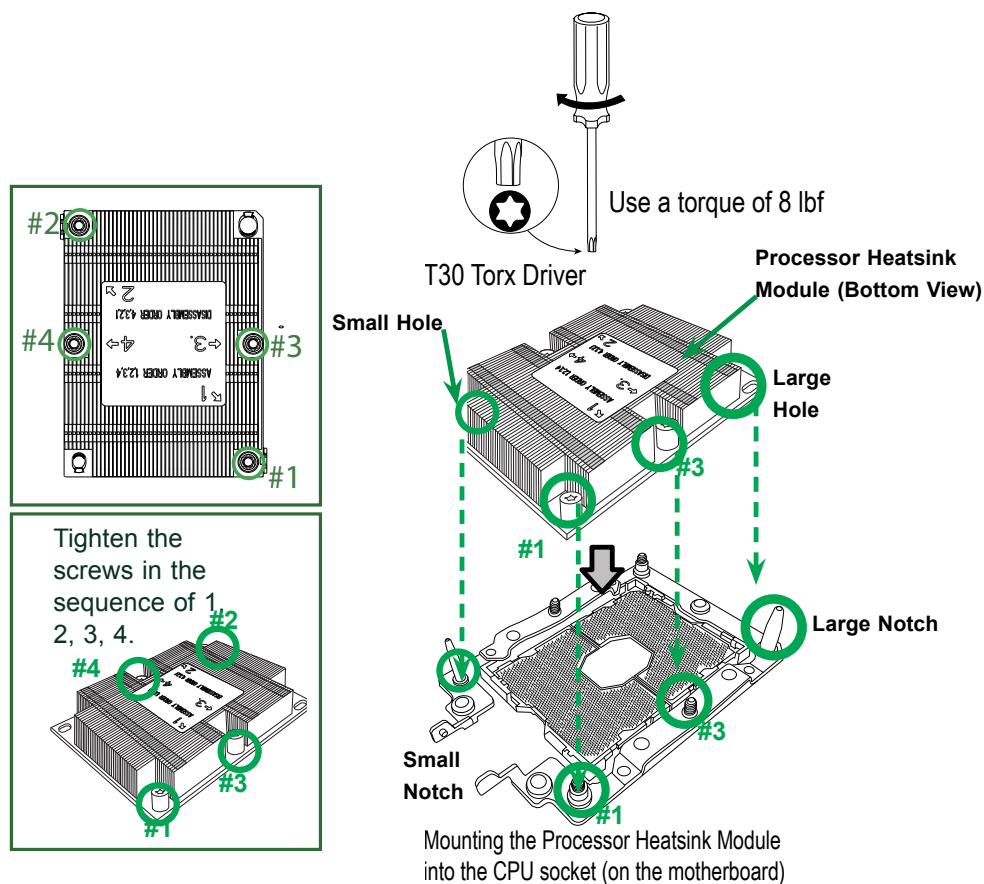

Removing the Processor Heatsink Module (PHM)

Before starting to remove the processor heatsink module (PHM), unplug power cord from the power outlet.

1. Using a T30-size star driver, turn the screws on the PHM counterclockwise to loosen it from the socket, starting with screw marked #4 (in the sequence of 4, 3, 2, 1).
2. After all four screws are removed, wiggle the PHM gently and pull up to remove it from the socket.

Note: To properly remove the processor heatsink module, be sure to loosen and remove the screws on the PHM in the sequence of 4, 3, 2, 1 as shown below.

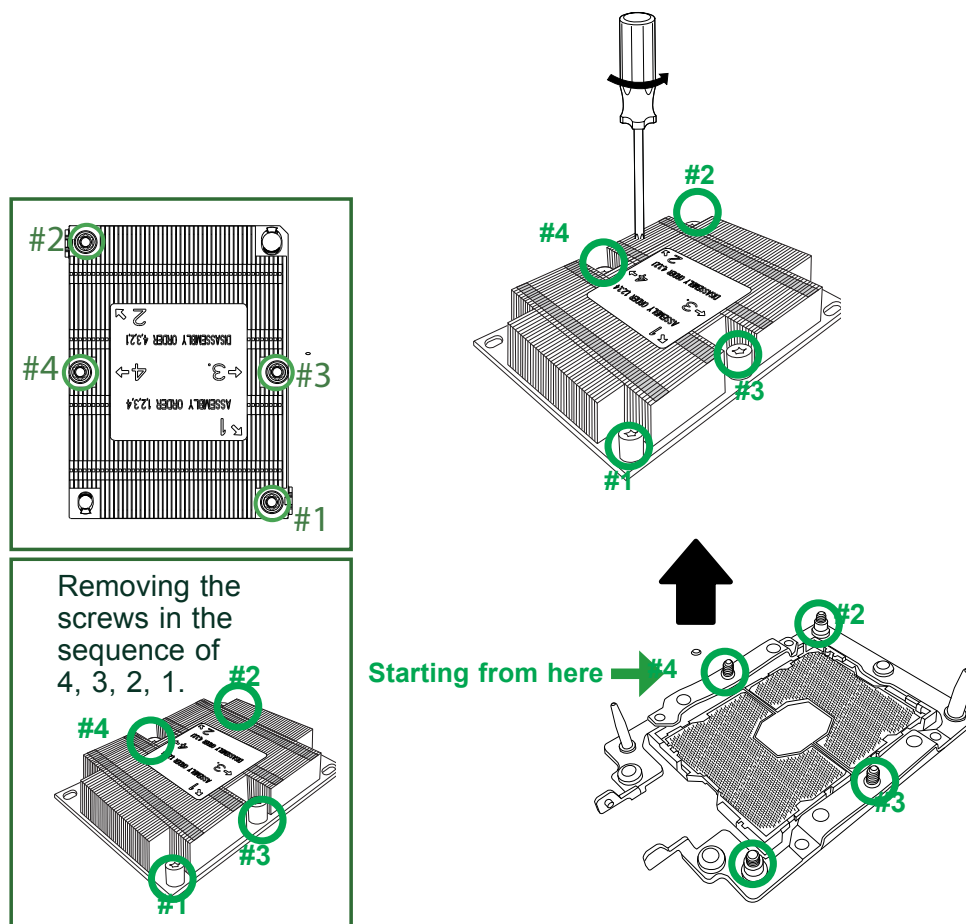

Memory Support and Installation

Note: Check the Supermicro website for recommended memory modules.

Important: Exercise extreme care when installing or removing DIMM modules to prevent any damage.

Memory Support

The X11DPFR-S/SNX11DPFR-S/SN supports up to 1536 GB of LRDIMM, Registered DIMM (RDIMM), and Non-Volatile DIMM (NV-DIMM) DDR4 (288-pin) ECC 2666/2400/2133 Mhz modules in twelve (12) slots. Populating these DIMM modules with a pair of memory modules of the same type and size will result in interleaved memory, which will improve memory performance.

Notes: 1. Be sure to use the memory modules of the same type and speed on the motherboard. Mixing of memory modules of different types and speeds is not allowed.

DDR4 Memory Support for the Intel Xeon 81xx/61xx/51xx/41xx/31xx Series Processors				
Type	Ranks Per DIMM and Data Width	DIMM Capacity (GB)		Speed (MT/s); Voltage (V); Slots per Channel (SPC) and DIMMs per Channel (DPC)
				1 Slot per Channel
		1DPC (1-DIMM per Channel)		
		4 GB	8 GB	1.2 V
RDIMM	SRx4	8 GB	16 GB	2666
RDIMM	SRx8	4 GB	8 GB	2666
RDIMM	DRx8	8 GB	16 GB	2666
RDIMM	DRx4	16 GB	32 GB	2666
RDIMM 3Ds	QRX4	N/A	2H-64GB	2666
	8RX4	N/A	4H-128GB	2666
LRDIMM	QRx4	32 GB	64 GB	2666
LRDIMM 3Ds	QRX4	N/A	2H-64GB	2666
	8Rx4	N/A	4H-128 GB	2666

DIMM Population Requirements

For optimal memory performance, follow the tables below when populating memory modules.

Key Parameters for DIMM Configurations	
Parameters	Possible Values
Number of Channels	1, 2, 3, 4, 5, or 6
Number of DIMMs per Channel	1DPC (1 DIMM Per Channel)
DIMM Type	RDIMM (w/ECC), LRDIMM, 3DS-LRDIMM
DIMM Construction	non-3DS RDIMM Raw Cards: A/B (2RX4), C (1RX4), D (1RX8), E (2RX8) 3DS RDIMM Raw Cards: A/B (4RX4) non-3DS LRDIMM Raw Cards: D/E (4RX4) 3DS LRDIMM Raw Cards: A/B (8RX4)

General Population Requirements

DIMM Mixing Rules

- All DIMMs must be DDR4 DIMMs only.
- X4 and X8 DIMMs can be mixed in the same channel.
- Mixing of LRDIMMs and RDIMMs is not allowed in the same channel, across different channels, and across different sockets.
- Mixing of non-3DS and 3DS LRDIMM is not allowed in the same channel, across different channels, and across different sockets.

Mixing of DIMM Types within a Channel

DIMM Types	RDIMM	LRDIMM	3DS LRDIMM
RDIMM	Allowed	Not Allowed	Not Allowed
LRDIMM	Not Allowed	Allowed	Not Allowed
3DS LRDIMM	Not Allowed	Not Allowed	Allowed

DDR4 Only Socket Level Population Requirements

DDR4 Socket Level Minimum Population Requirements

- There should be at least one DDR4 DIMM per socket.
- If only one DIMM is populated in a channel, then populate it in the slot furthest away from CPU.
- Always populate DIMMs with a higher electrical loading in DIMM0 followed by DIMM1.

DDR4 Only Memory Populations with Possible Mixes

DDR4 RDIMM		DIMM0/DIMM1 Config. Set A	DIMM0/DIMM1 Config. Set B	DIMM0/DIMM1 Config. Set C	Possible Mixes DIMM0/DIMM1
Within IMC DIMM Population	DDR0	x8, None, x8, x8	x4, None, x4, x4	x8, x4, or x4, x8	Single Rank, None
	DDR1	None or same as DDR0	None or same as DDR0	None or same as DDR0	Single Rank, Single Rank Dual Rank, Single Rank, Dual Rank, None
	DDR2	None or same as DDR1 (excludes DIMM 1 in 5DIMM configurations)	None or same as DDR1 (excludes DIMM 1 in 5DIMM configurations)	None or same as DDR1 (excludes DIMM 1 in 5DIMM configurations)	Dual Rank, Dual Rank, Single Rank, Single Rank

DDR4 Only Memory Populations with Possible Mixes

3DS LRDIMM or 3DS RDIMM		DIMM0/DIMM1 Config. Set A	Possible Mixes DIMM0/DIMM1
Within IMC DIMM Population	DDR0	x4, None, x4, x4	Quad Rank, None
	DDR1	None or same as DDR0	Quad Rank, Quad Rank
	DDR2	None or same as DDR1	Cannot mix 3DS LRDIMM and RDIMM

DDR4 Only Memory Populations with Possible Mixes			
LRDIMMs		DIMM0/DIMM1	Possible Mixes DIMM0/DIMM1
Within IMC DIMM Population	DDR0	x4, None, x4, x4	Quad Rank, None
	DDR1	None or same as DDR0	Quad Rank, Quad Rank
	DDR2	None or same as DDR1	Note: Requirements *Match DIMM types installed across DDR channels within an IMC *Always populate iMC0 first

DDR4 Only 2SPC Memory Configuration with x8 DIMMs				
	Total # of DIMMs	DDR Channel	Number of Ranks	Virtual Lock Step
DIMM Population within an IMC (Note: Uniformly populate with x8 DRAMs DIMMs)	1 x8 DIMM	Must be installed on iMC0 DDR Channel 0	1	N/A
	2 x8 DIMMs	DDR0: Populate with 1 DIMM DDR1: Populate identically as DDR0	>1	SVLS
			1	N/A
	3 x8 DIMMs	DDR0: Populate with 1 DIMM DDR1: Populate identically as DDR0 DDR2: Populate identically as DDR1	>1	SVLS
			1	N/A
	4 x8 DIMMs	DDR0: Populate with 2 DIMMs DDR1: Populate identically as DDR0	>1	SVLS
			x	SVLS
5 x8 DIMMs	DDR Channel 0, 1, 2: DIMM0 is populated with identical DIMMs, DDR Channel 0, 1: DIMM1 is populated with identical DIMMs	>1	SVLS	
6 x8 DIMMs	Populate 2 DIMMs per DDR channel	x	SVLS	
DIMM Population within an IMC (Note: Non-equal in rank pair of x8 DIMMs)	1 pair of DIMMs	DDR0: Populate with 1 DIMM DDR1: Populate the second DIMM (for best performance)	1	N/A
			>1	SVLS
	2 pairs of DIMMs	DDR0: Populate with 1 pair of non-equal rank DIMMs DDR1: Populate identically as DDR0	1	N/A
			>1	SVLS
	3 pairs of DIMMs	DDR0: Populate with 1 pair of non-equal rank DIMMs DDR1: Populate identically as DDR0 DDR2: Populate identically as DDR1	x	SVLS
2 pairs+1 (5DIMMs)	DDR0: Populate with 1 pair of non-equal rank DIMMs DDR1: Populate with identical DIMMs as DDR0 DDR2: DIMM0 is populated with identical DIMM as DDR1	>1	SVLS	

DDR4 Only 2SPC Memory Configuration with x4 DIMMs				
	Total # of DIMMs	DDR Channel	Number of Ranks	Adaptive Virtual Lock Step
DIMM Population within an IMC Note: Uniformly populate with x4 DRAMs/DIMMs	1 x4 DIMM	Must be installed on iMC0 DDR Channel 0	1	Y, only Bank VLS
	2 x4 DIMMs	DDR0: Populate with 1 DIMM DDR1: Populate identically as DDR0	>1	Y
			1	Y, only Bank VLS
	3 x4 DIMMs	DDR0: Populate with 1 DIMM DDR1: Populate identically as DDR0 DDR2: Populate identically as DDR1	>1	Y
			1	Y, only Bank VLS
	4 x4 DIMMs	DDR0: Populate with 2 DIMMs DDR1: Populate identically as DDR0	>1	Y
			x	Y
5 x4 DIMMs	DDR Channel 0, 1, 2: DIMM0 is populated with identical DIMMs, DDR Channel 0, 1: DIMM1 is populated with identical DIMMs	>1	Y	
6 x4 DIMMs	Populate 2 DIMMs per DDR channel	x	Y	
DIMM Population within an IMC Note: Non-equal in rank pair of x4 DIMMs)	1 pair of DIMMs	DDR0: Populate with 1 DIMM DDR1: Populate the second DIMM (for best performance)	>1	Y
	2 pairs of DIMMs	DDR0: Populate with 1 pair of non-equal rank DIMMs DDR1: Populate identically as DDR0	>1	Y
	3 pairs of DIMMs	DDR0: Populate with 1 pair of non-equal rank DIMMs DDR1: Populate identically as DDR0 DDR2: Populate identically as DDR1	x	Y
	2 pairs+1 (5DIMMs)	DDR0: Populate with 1 pair of non-equal rank DIMMs DDR1: Populate with identical DIMMs as DDR0 DDR2: DIMM0 is populated with identical DIMM as DDR1	>1	Y

DDR4 Only 2SPC Memory Configuration with x8/x4 DIMMs Mixed			
DDR4 RDIMM	Total # of DIMMs	DDR Channel	ADDC/SDDC Features
DIMM Population within an IMC	1 pair of x8, x4	DDR0: Populate with 1 DIMM DDR1: Populate the second DIMM (for best performance)	No
	2 pairs of x8, x4	Populate with 1 pair of DIMMs on DDR0, and identical pair on DDR1	No
	3 pairs of x8, x4	A pair of DIMMs on DDR0, and identical pair on DDR1, and DDR2	No

DIMM Installation

1. Insert DIMM modules in the following order: For CPU1, begin with P1-DIMMC1, P1-DIMMB1, P1-DIMMA1 then P1-DIMMF1, P1-DIMME1, P1-DIMMD1. For CPU2, begin with P2-DIMMC1, P2-DIMMB1, P2-DIMMA1 then P2-DIMMF1, P2-DIMME1, P2-DIMMD1. For the system to work properly, please use memory modules of the same type and speed on the motherboard.

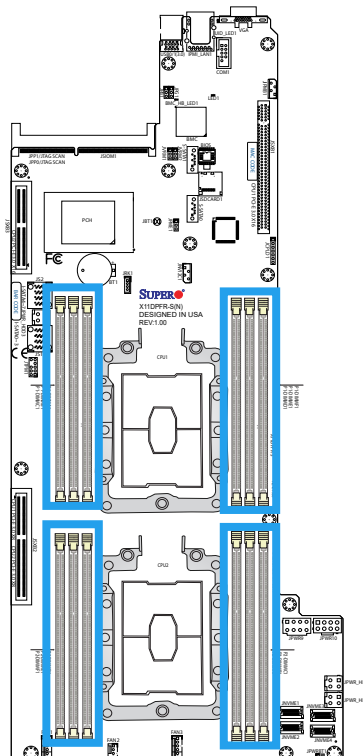

2. Push the release tabs outwards on both ends of the DIMM slot to unlock it.
3. Align the key of the DIMM module with the receptive point on the memory slot.
4. Align the notches on both ends of the module against the receptive points on the ends of the slot.
5. Use two thumbs together to press the notches on both ends of the module straight down into the slot until the module snaps into place.
6. Press the release tabs to the lock positions to secure the DIMM module into the slot.

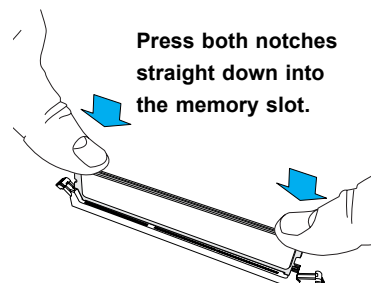
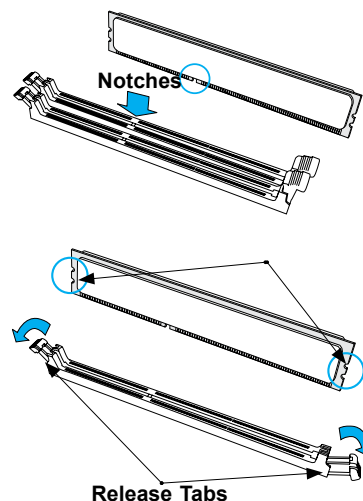

DIMM Removal

Reverse the steps above to remove the DIMM modules from the motherboard.

Motherboard Battery

The motherboard uses non-volatile memory to retain system information when system power is removed. This memory is powered by a lithium battery residing on the motherboard.

Replacing the Battery

Begin by removing power from the system as described in section 3.1.

1. Push aside the small clamp that covers the edge of the battery. When the battery is released, lift it out of the holder.
2. To insert a new battery, slide one edge under the lip of the holder with the positive (+) side facing up. Then push the other side down until the clamp snaps over it.

Note: Handle used batteries carefully. Do not damage the battery in any way; a damaged battery may release hazardous materials into the environment. Do not discard a used battery in the garbage or a public landfill. Please comply with the regulations set up by your local hazardous waste management agency to dispose of your used battery properly.

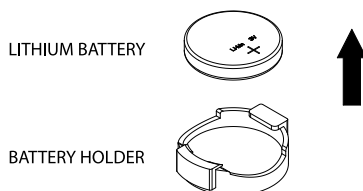

Figure 3-22. Installing the Onboard Battery

Warning: There is a danger of explosion if the onboard battery is installed upside down (which reverses its polarities). This battery must be replaced only with the same or an equivalent type recommended by the manufacturer (CR2032).

Chapter 4

Motherboard Connections

This section describes the connections on the motherboard and provides pinout definitions. Note that depending on how the system is configured, not all connections are required. The LEDs on the motherboard are also described here. A severboard layout indicating component locations may be found in Chapter 1.

Please review the Safety Precautions in Chapter 3 before installing or removing components.

4.1 Power Connections

Two power connections on the X11DPFR-S must be connected to the power supply. The wiring is included with the power supply.

- 8-pin Processor Power Connectors (JPW9/JPW10)

12V 8-pin GPU Power Connectors

JPW9-JPW10 are the 8-pin 12V DC power input from the Power Adapter Board.

12V 8-pin Power Pin Definitions		
Connector	Pin#	Definition
JPWR9	1-8	12V
JPWR10	1-8	GND

Required Connection

4.2 Headers and Connectors

Fan Headers

This motherboard has three fan headers (FAN1~3). This is a 4-pin fan header, which is backward compatible with a traditional 3-pin fan. The onboard fan speed is controlled by Thermal Management (via Hardware Monitoring) in the BIOS. When using Thermal Management setting, please use all 3-pin fans or all 4-pin fans.

Fan Header Pin Definitions	
Pin#	Definition
1	Ground (Black)
2	+12V (Red)
3	Tachometer
4	PWM Control

TPM Header

The JTPM1 header is used to connect a Trusted Platform Module (TPM)/Port 80, which is available from a third-party vendor. A TPM/Port 80 connector is a security device that supports encryption and authentication in hard drives. It allows the motherboard to deny access if the TPM associated with the hard drive is not installed in the system. See the table below for pin definitions.

Trusted Platform Module/Port 80 Header Pin Definitions			
Pin#	Definition	Pin#	Definition
1	+3.3V	2	SPI_CS#
3	RESET#	4	SPI_MISO
5	SPI_CLK	6	GND
7	SPI_MOSI	8	
9	+3.3V Stdby	10	SPI_IRQ#

RAID Key Header

A RAID Key header is located at JRK1 on the motherboard. The RAID key is used to support onboard NVMe connections.

Intel RAID Key Pin Definitions	
Pins	Definition
1	GND
2	PU 3.3V Stdby
3	GND
4	PCH RAID KEY

Micro SD Card

There is one Micro SD memory card slot located at JSDCARD1 on the motherboard.

I-SATA 3.0 and S-SATA 3.0 Ports

The X11DPFR-S(N) has two MiniSAS-HD connectors (I-SATA0~3, I-SATA4~7) and two SATADOM ports (S-SATA0/1). These SATA ports are supported by the Intel C621 chipset.

NVMe I²C Header

JNVI²C1 is a sideband header for NVMe devices connected to CPU1. Please connect the I²C cable to this connector.

NVMe OcuLink Connectors

Use the four NVMe OcuLink Connectors (JNVME1, JNVME2, JNVME3, JNVME4) to attach high-speed PCI-E storage devices.

4.3 Rear I/O Ports

See the figure below for the locations and descriptions of the various I/O ports on the rear of the motherboard.

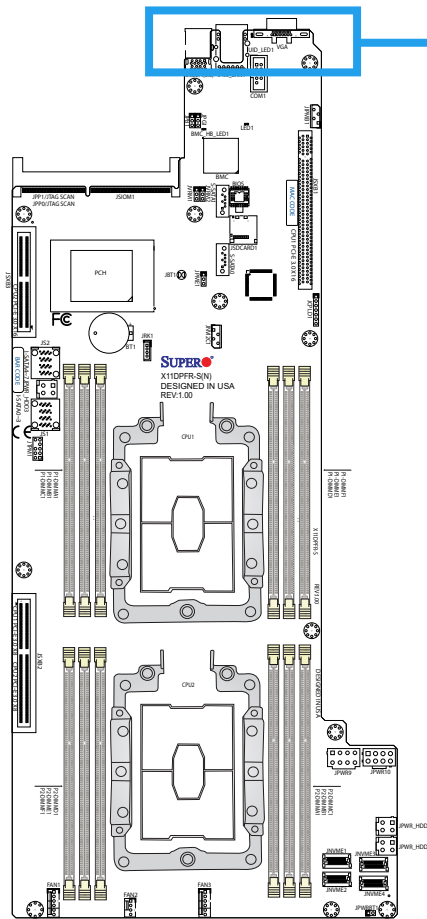

Back panel I/O Port Locations and Definitions

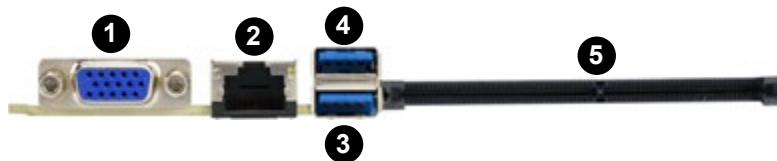

Back Panel I/O Ports			
No.	Description	No.	Description
1.	VGA port	4.	USB0 (3.0)
2.	Dedicated IPMI LAN	5.	SIOM slot
3.	USB1 (3.0)		

VGA Port

The onboard VGA port is located next to IPMI LAN port on the I/O back panel. Use this connection for VGA display.

UID LED Indicator

A UID LED Indicator (LE1) is located on the I/O back panel. The UID Indicator provides easy identification of a system unit that may be in need of service.

Note: UID can also be triggered via IPMI on the motherboard. For more information on IPMI, please refer to the IPMI User's Guide posted on our website at <http://www.supermicro.com>.

UID LED Pin Definitions	
Color	Status
Blue: On	Unit Identified

Universal Serial Bus (USB) Ports

There are two USB 3.0 ports (USB0/1) on the I/O back panel.

Back Panel USB0/1 (3.0) Pin Definitions			
Pin#	Definition	Pin#	Definition
1	VBUS	10	Power
2	D-	11	USB 2.0 Differential Pair
3	D+	12	
4	Ground	13	Ground of PWR Return
5	StdA_SSRX-	14	SuperSpeed Receiver
6	StdA_SSRX+	15	Differential Pair
7	GND_DRAIN	16	Ground for Signal Return
8	StdA_SSTX-	17	SuperSpeed Transmitter
9	StdA_SSTX+	18	Differential Pair

Ethernet Ports

One dedicated IPMI LAN is located on the I/O back panel. This LAN port is supported by the onboard AST 2500 BMC and accepts an RJ45 type cable. Refer to the LED Indicator Section for the IPMI LAN LED information.

4.4 Front Control Panel

JF1 contains header pins for various control panel connections. See the figure below for the pin locations and definitions of the control panel buttons and LED indicators.

All JF1 wires have been bundled into a single cable to simplify this connection. Make sure the red wire plugs into pin 1 as marked on the motherboard. The other end connects to the control panel PCB board.

Note: Since there are no LAN ports, only an IPMI LAN port, for this system, both NIC pinouts are not used.

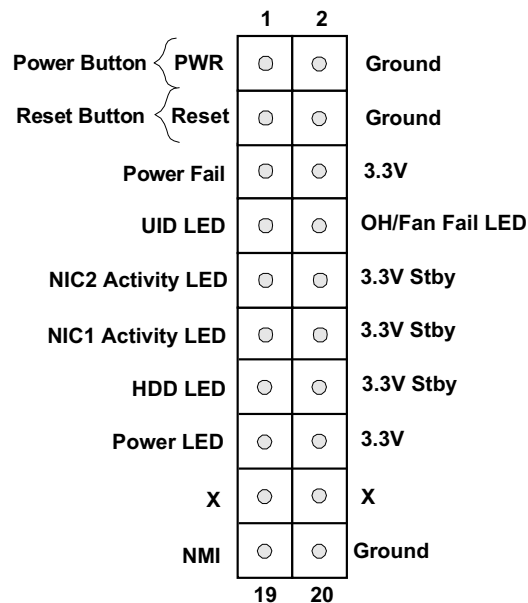

Figure 4-1. JF1: Control Panel Pins

Power Button

The Power Button connection is located on pins 1 and 2 of JF1. Momentarily contacting both pins will power on/off the system. This button can also be configured to function as a suspend button (with a setting in the BIOS - see Chapter 4). To turn off the power when the system is in suspend mode, press the button for 4 seconds or longer. Refer to the table below for pin definitions.

Power Button Pin Definitions (JF1)	
Pins	Definition
1	Signal
2	Ground

Reset Button

The Reset Button connection is located on pins 3 and 4 of JF1. Attach it to a hardware reset switch on the computer case to reset the system. Refer to the table below for pin definitions.

Reset Button Pin Definitions (JF1)	
Pins	Definition
3	Reset
4	Ground

Power Fail LED

The Power Fail LED connection is located on pins 5 and 6 of JF1. Refer to the table below for pin definitions.

Power Fail LED Pin Definitions (JF1)	
Pin#	Definition
5	3.3V
6	PWR Supply Fail

Fan Fail and UID LED

Connect an LED cable to pins 7 and 8 of the front control panel to use the Overheat/Fan Fail LED connections. The LED on pin 8 provides warnings of overheat or fan failure. Refer to the tables below for pin definitions.

OH/Fan Fail Indicator Status	
State	Definition
Off	Normal
On	Overheat
Flashing	Fan Fail

OH/Fan Fail LED Pin Definitions (JF1)	
Pin#	Definition
7	Blue LED
8	OH/Fan Fail LED

HDD LED

The HDD LED connection is located on pins 13 and 14 of JF1. Attach a cable to pin 14 to show hard drive activity status. Refer to the table below for pin definitions.

HDD LED Pin Definitions (JF1)	
Pins	Definition
13	3.3V Stdby
14	HDD Active

Power LED

The Power LED connection is located on pins 15 and 16 of JF1. Refer to the table below for pin definitions.

Power LED Pin Definitions (JF1)	
Pins	Definition
15	3.3V
16	PWR LED

NMI Button

The non-maskable interrupt (NMI) button header is located on pins 19 and 20 of JF1. Refer to the table below for pin definitions.

NMI Button Pin Definitions (JF1)	
Pins	Definition
19	Control
20	Ground

4.5 Jumpers

Explanation of Jumpers

To modify the operation of the motherboard, jumpers are used to choose between optional settings. Jumpers create shorts between two pins to change the function associated with it. Pin 1 is identified with a square solder pad on the printed circuit board. See the motherboard layout page for jumper locations.

Note: On a two-pin jumper, "Closed" means the jumper is on both pins and "Open" indicates the jumper is either on only one pin or has been completely removed.

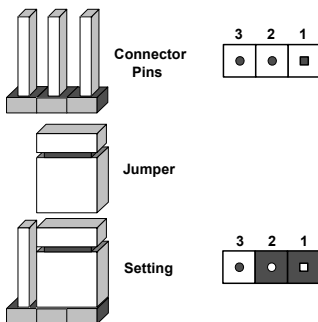

CMOS Clear

JBT1 is used to clear CMOS, which will also clear any passwords. Instead of pins, this jumper consists of contact pads to prevent accidentally clearing the contents of CMOS.

To Clear CMOS

1. First power down the system and unplug the power cord(s).
2. Remove the cover of the chassis to access the motherboard.
3. Remove the onboard battery from the motherboard.
4. Short the CMOS pads with a metal object such as a small screwdriver for at least four seconds.
5. Remove the screwdriver (or shorting device).
6. Replace the cover, reconnect the power cord(s) and power on the system.

Notes: Clearing CMOS will also clear all passwords.

Do not use the PW_ON connector to clear CMOS.



JBT1 contact pads

VGA Enable/Disable

JPG1 allows you to enable or disable the VGA port using the onboard graphics controller. The default setting is Enabled.

VGA Enable/Disable Jumper Settings	
Jumper Setting	Definition
Pins 1-2	Enabled
Pins 2-3	Disabled

Management Engine (ME) Recovery

Use jumper JPME1 to select ME Firmware Recovery mode, which will limit resource allocation for essential system operation only in order to maintain normal power operation and management. In the single operation mode, online upgrade will be available via Recovery mode. See the table below for jumper settings.

ME Recovery Mode Jumper Settings	
Jumper Setting	Definition
Pins 1-2	Normal
Pins 2-3	ME Recovery

I²C Bus for VRM

Jumper JVRM1 allows the BMC or the PCH to access CPU and memory VRM controllers. See the table below for jumper settings.

VRM Jumper Settings	
Jumper Setting	Definition
Pins 1-2	BMC (Normal)
Pins 2-3	PCH

4.6 LED Indicators

IPMI LAN LEDs

A dedicated IPMI LAN, located on the back panel, has two LED indicators. The amber LED on the right of the IPMI LAN port indicates activity, while the LED on the left indicates the speed of the connection. See the table below for more information.

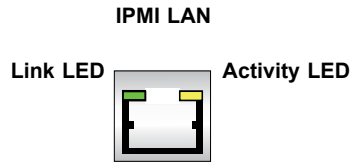

IPMI LAN LEDs		
	Color/State	Definition
Link (left)	Green: Solid	100 Mbps
	Amber: Solid	1Gbps
Activity (Right)	Amber: Blinking	Active

BMC Heartbeat LED

BMC_HB_LED1 is the BMC heartbeat LED. When the LED is blinking green, BMC is functioning normally. See the table below for the LED status.

Onboard Power LED Indicator	
LED Color	Definition
Green: Blinking	BMC Normal

Unit ID LED

A rear UID LED indicator at UID_LED1 is located near the UID switch on the back panel. This UID indicator provides easy identification of a system unit that may need service.

UID LED LED Indicator	
LED Color	Definition
Blue: On	Unit Identified

4.7 PCI-E 3.0 Slots

PCI-E 3.0 Slots

There are several PCI-E slots located on the motherboard. Refer to the layout below for their locations.

1. PCI-E 3.0 x16 Right Riser Card (JSXB1)
2. PCI-E 3.0 x16 (x8+x8) SMC I Proprietary slot (JSXB2)
3. PCI-E3.0 x16 SIOM LAN Port (not shown)

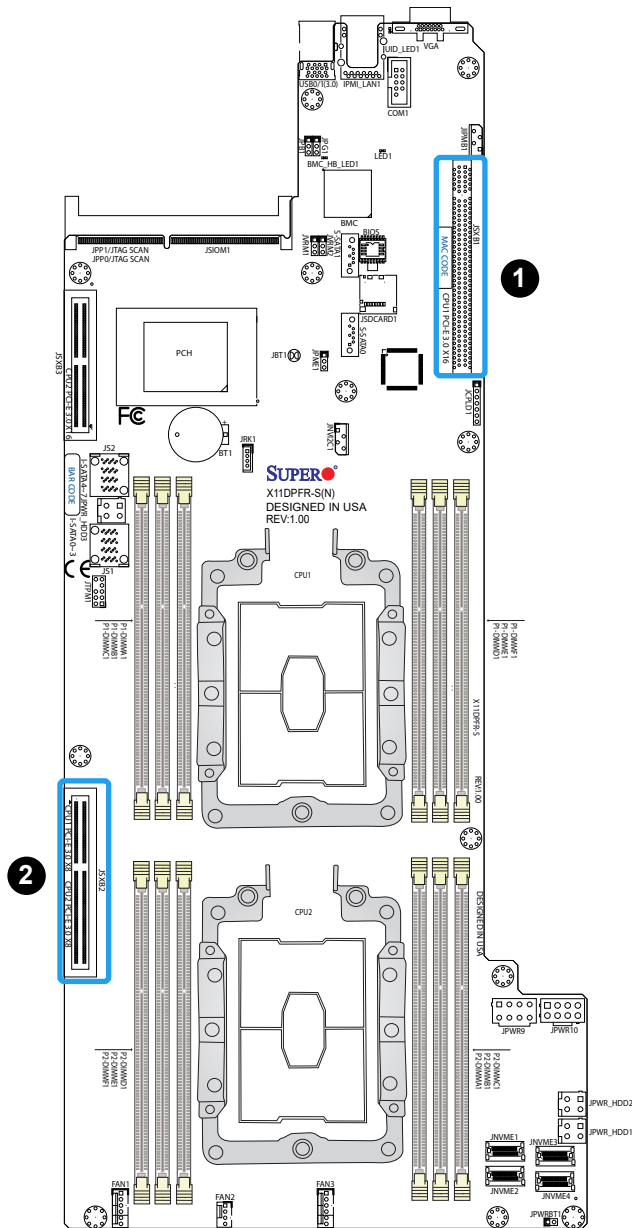

Chapter 5

Software

After the hardware has been installed, you should install the Operating System (OS), configure RAID settings and install the drivers. Necessary drivers and utilities may be found at <ftp://ftp.supermicro.com/driver>.

5.1 OS Installation

You must first configure RAID settings (if using RAID) before you install the Windows OS and the software drivers. To configure RAID settings, please refer to the RAID Configuration User Guides posted on our website at www.supermicro.com/support/manuals.

Installing the Windows OS for a RAID System

1. Insert Microsoft's Windows Setup DVD in the DVD drive and the system will start booting up from the DVD.
2. Insert the USB stick containing Windows drivers to a USB port on the system.
Note: for older legacy OS's, please use a method to slipstream the drivers.
3. Select the partition on the drive in which to install Windows.
4. Browse the USB folder for the proper driver files.
5. Choose the RAID driver indicated in the Windows OS Setup screen, then choose the hard drive in which you want to install it.
6. Once all devices are specified, continue with the installation.
7. After the Windows OS installation is completed, the system will automatically reboot.

Installing Windows to a Non-RAID System

1. Insert Microsoft's Windows OS Setup DVD in the DVD-ROM drive and the system will start booting up from the DVD.
2. Continue with the installation. The Windows OS Setup screen will display.
3. From the Windows OS Setup screen, press the <Enter> key. The OS Setup will automatically load all device files and then continue with the Windows installation.
4. After the installation has completed, the system will automatically reboot.

5.2 Driver Installation

The Supermicro FTP site contains drivers and utilities for your system at <ftp://ftp.supermicro.com>. Some of these must be installed, such as the chipset driver.

After accessing the FTP site, go into the CDR_Images directory and locate the ISO file for your motherboard. Download this file to create a DVD of the drivers and utilities it contains. (You may also use a utility to extract the ISO file if preferred.)

After creating a DVD with the ISO files, insert the disk into the DVD drive on your system and the display shown in Figure 5-1 should appear.

Another option is to go to the Supermicro website at <http://www.supermicro.com/products/>. Find the product page for your motherboard here, where you may download individual drivers and utilities to your hard drive or a USB flash drive and install from there.

Note: To install the Windows OS, please refer to the instructions posted on our website at <http://www.supermicro.com/support/manuals/>.

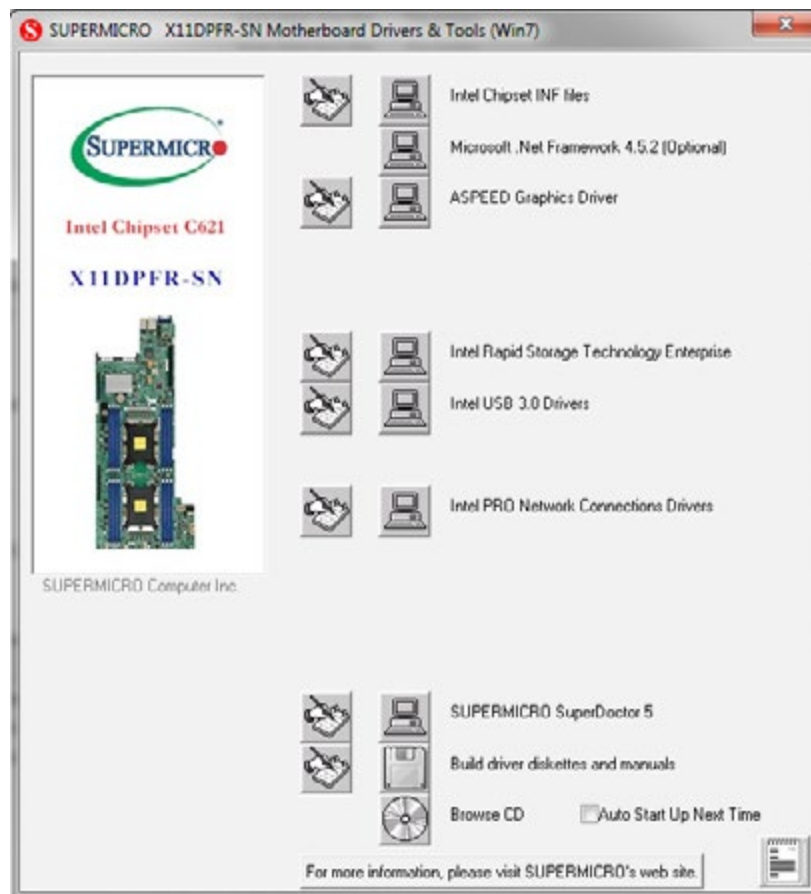

Figure 5-1. Driver & Tool Installation Screen

Note: Click the icons showing a hand writing on paper to view the readme files for each item. Click the computer icons to the right of these items to install each item (from top to the bottom) one at a time. **After installing each item, you must re-boot the system before moving on to the next item on the list.** The bottom icon with a CD on it allows you to view the entire contents.

5.3 SuperDoctor® 5

The Supermicro SuperDoctor 5 is a program that functions in a command-line or web-based interface for Windows and Linux operating systems. The program monitors such system health information as CPU temperature, system voltages, system power consumption, fan speed, and provides alerts via email or Simple Network Management Protocol (SNMP).

SuperDoctor 5 comes in local and remote management versions and can be used with Nagios to maximize your system monitoring needs. With SuperDoctor 5 Management Server (SSM Server), you can remotely control power on/off and reset chassis intrusion for multiple systems with SuperDoctor 5 or IPMI. SuperDoctor 5 Management Server monitors HTTP, FTP, and SMTP services to optimize the efficiency of your operation.

Note: The default User Name and Password for SuperDoctor 5 is admin / admin.



Figure 5-2. SuperDoctor 5 Interface Display Screen (Health Information)

5.4 IPMI

The X11DPFR-S/SN support the Intelligent Platform Management Interface (IPMI). IPMI is used to provide remote access, monitoring and management. There are several BIOS settings that are related to IPMI.

For general documentation and information on IPMI, please visit our website at: <http://www.supermicro.com/products/nfo/IPMI.cfm>.

Chapter 6

BIOS

6.1 Introduction

This chapter describes the AMIBIOS™ Setup utility for the X11DPFR-S/SN motherboard(s). The is stored in a flash chip and can be easily upgraded using a floppy disk-based program.

Note: Due to periodic changes to the BIOS, some settings may have been added or deleted and might not yet be recorded in this manual. Please refer to the Manual Download area of our website for any changes to BIOS that may not be reflected in this manual.

Starting the Setup Utility

To enter the BIOS Setup Utility, hit the <Delete> key while the system is booting-up. (In most cases, the <Delete> key is used to invoke the BIOS setup screen. There are a few cases when other keys are used, such as <F1>, <F2>, etc.) Each main BIOS menu option is described in this manual.

The Main BIOS screen has two main frames. The left frame displays all the options that can be configured. "Grayed-out" options cannot be configured. The right frame displays the key legend. Above the key legend is an area reserved for a text message. When an option is selected in the left frame, it is highlighted in white. Often a text message will accompany it. (Note that BIOS has default text messages built in. We retain the option to include, omit, or change any of these text messages.) Settings printed in Bold are the default values.

A " ►" indicates a submenu. Highlighting such an item and pressing the <Enter> key will open the list of settings within that submenu.

The BIOS setup utility uses a key-based navigation system called hot keys. Most of these hot keys (<F1>, <F10>, <Enter>, <ESC>, <Arrow> keys, etc.) can be used at any time during the setup navigation process.

6.2 Main Menu

When you first enter AMI BIOS Setup Utility, you will see the Main Menu screen. You can always return to the Main Menu by selecting the **Main** tab on the top of the screen with the arrow keys.

The Main Menu screen provides you with a system overview, which includes the version, built date and ID of the AMIBIOS, the type, speed and number of the processors in the system and the amount of memory installed in the system.

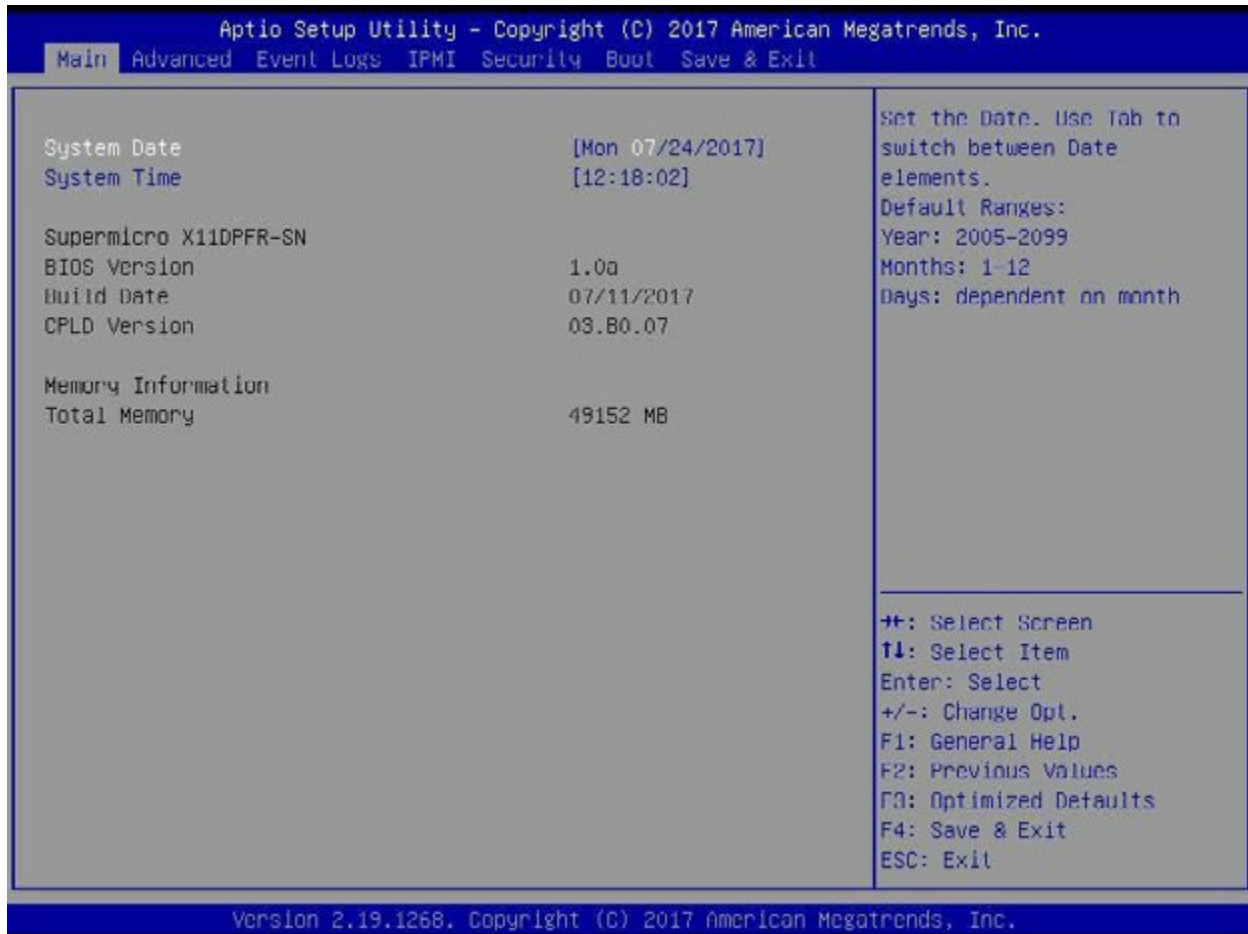

System Time/System Date

You can edit this field to change the system time and date. Highlight System Time or System Date using the <Arrow> keys. Enter new values through the keyboard. Press the <Tab> key or the <Arrow> keys to move between fields. The date must be entered in DAY/MM/DD/YYYY format. The time is entered in HH:MM:SS format. Please note that time is in a 24-hour format. For example, 5:30 A.M. appears as 05:30:00 and 5:30 P.M. as 17:30:00.

System Date/System Time

Use this item to change the system date and time. Highlight System Date or System Time using the arrow keys. Enter new values using the keyboard. Press the <Tab> key or the arrow keys to move between fields. The date must be entered in Day MM/DD/YYYY format. The time is entered in HH:MM:SS format.

Note: The time is in the 24-hour format. For example, 5:30 P.M. appears as 17:30:00. The date's default value is 01/01/2014 after RTC reset.

Supermicro X11DPFR-S(N)

BIOS Version

This item displays the version of the BIOS ROM used in the system.

Build Date

This item displays the date when the version of the BIOS ROM used in the system was built.

CPLD Version

This item displays the version of the CPLD (Complex-Programmable Logical Device) used in the system.

Memory Information

Total Memory

This item displays the total size of memory available in the system.

6.3 Advanced Settings Menu

Use the arrow keys to select the Advanced submenu and press <Enter> to access the submenu items:

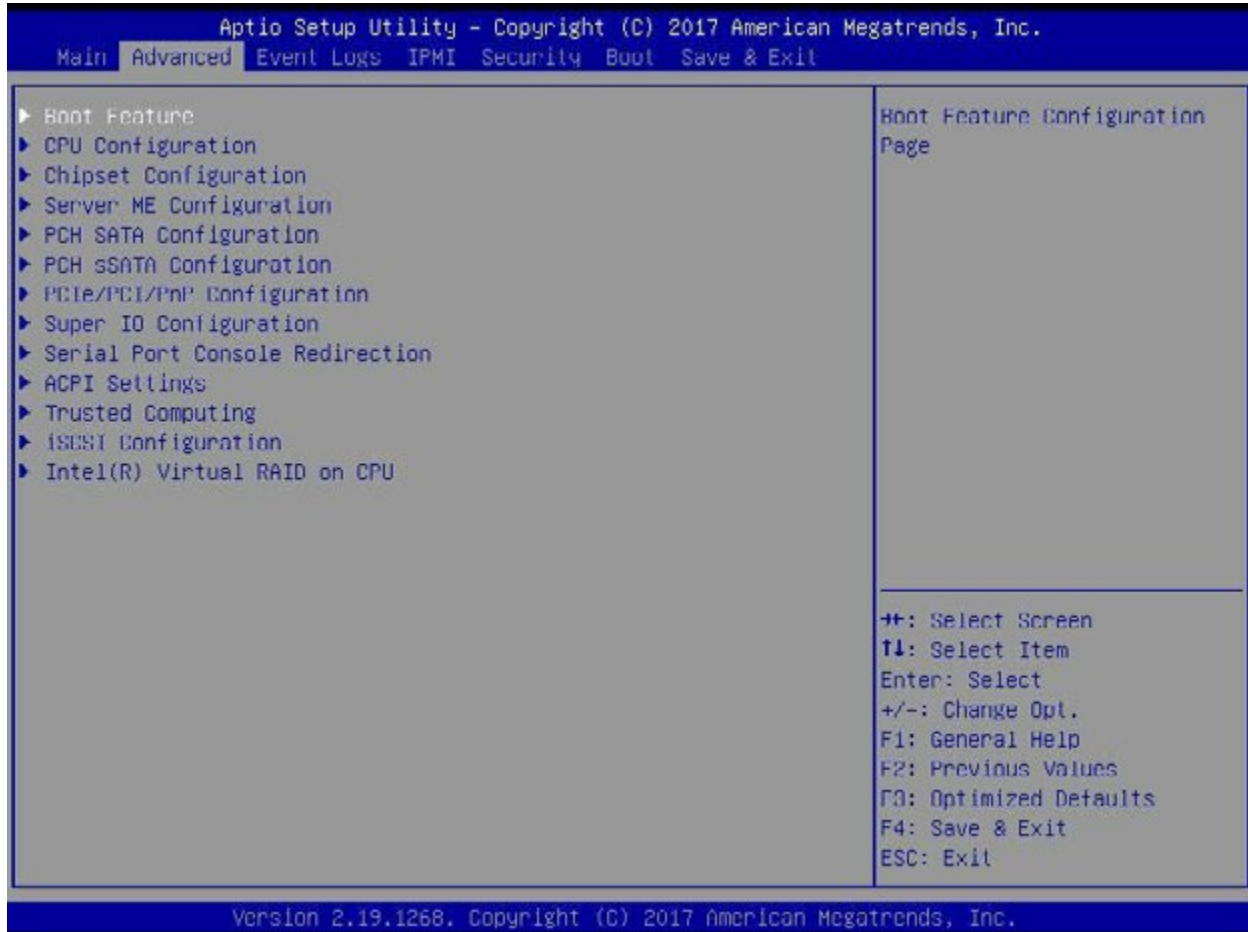

Warning: Take Caution when changing the Advanced settings. An incorrect value, an incorrect DRAM frequency, or an incorrect BIOS timing setting may cause the system to malfunction. When this occurs, restore the setting to the manufacture default setting.

▶ Boot Feature

Quiet Boot

Use this feature to select the screen between displaying POST messages or the OEM logo at bootup. Select Disabled to display the POST messages. Select Enabled to display the OEM logo instead of the normal POST messages. The options are Enabled and Disabled.

Note: POST message is always displayed regardless of the item setting.

Option ROM Messages

Use this feature to set the display mode for the Option ROM. Select Keep Current to use the current AddOn ROM display setting. Select Force BIOS to use the Option ROM display mode set by the system BIOS. The options are Force BIOS and Keep Current.

Bootup NumLock State

Use this feature to set the Power-on state for the Numlock key. The options are Off and **On**.

Wait For 'F1' If Error

Select Enabled to force the system to wait until the 'F1' key is pressed if an error occurs. The options are Disabled and **Enabled**.

Interrupt 19 (INT19) Trap Response

Interrupt 19 is the software interrupt that handles the boot disk function. When this item is set to Immediate, the ROM BIOS of the host adaptors will "capture" Interrupt 19 at bootup immediately and allow the drives that are attached to these host adaptors to function as bootable disks. If this item is set to Postponed, the ROM BIOS of the host adaptors will not capture Interrupt 19 immediately and allow the drives attached to these adaptors to function as bootable devices at bootup. The options are **Immediate** and Postponed.

Re-try Boot

When EFI (Expansible Firmware Interface) Boot is selected, the system BIOS will automatically reboot the system from an EFI boot device after an initial boot failure. Select Legacy Boot to allow the BIOS to automatically reboot the system from a Legacy boot device after an initial boot failure. The options are **Disabled**, Legacy Boot, and EFI Boot.

Install Windows 7 USB Support

Enable this feature to use the USB keyboard and mouse during the Windows 7 installation, since the native XHCI driver support is unavailable. Use a SATA optical drive as a USB drive, and USB CD/DVD drives are not supported. Disable this feature after the XHCI driver has been installed in Windows. The options are **Disabled** and Enabled.

Port 61h Bit-4 Emulation

Select Enabled to enable the emulation of Port 61h bit-4 toggling in SMM (System Management Mode). The options are **Disabled** and Enabled.

Power Configuration

Watch Dog Function

Select Enabled to allow the Watch Dog timer to reboot the system when it is inactive for more than 5 minutes. The options are Enabled and **Disabled**.

Restore on AC Power Loss

Use this feature to set the power state after a power outage. Select Stay Off for the system power to remain off after a power loss. Select Power On for the system power to be turned on after a power loss. Select Last State to allow the system to resume its last power state before a power loss. The options are Stay Off, Power On, and **Last State**.

Power Button Function

This feature controls how the system shuts down when the power button is pressed. Select 4 Seconds Override for the user to power off the system after pressing and holding the power button for 4 seconds or longer. Select Instant Off to instantly power off the system as soon as the user presses the power button. The options are **Instant Off** and 4 Seconds Override.

Throttle on Power FailThis feature allows the system to decrease system power requirements by throttling CPU frequency in the event of one power supply failing. The options are Enabled and **Disabled**.

▶CPU Configuration

Warning: Setting the wrong values in the following sections may cause the system to malfunction.

▶Processor Configuration

The following CPU information will be displayed:

Processor BSP Revision

Processor Socket

Processor ID

Processor Frequency

Processor Max Ratio

Processor Min Ratio

Microcode Revision

L1 Cache RAM

L2 Cache RAM

L3 Cache RAM

Processor 0 Version

Processor 1 Version

Hyper-Threading (ALL)

Select Enable to use Intel Hyper-Threading Technology to enhance CPU performance. The options are **Enable** and Disable.

Execute Disable Bit (Available if supported by the OS & the CPU)

Select Enable to enable Execute Disable Bit support which will allow the processor to designate areas in the system memory where an application code can execute and where it cannot, thus preventing a worm or a virus from flooding illegal codes to overwhelm the processor, damaging the system during a virus attack. The options are **Enable** and Disable. (Refer to Intel and Microsoft websites for more information.)

Intel Virtualization Technology

Select Enable to use Intel Virtualization Technology which will allow the I/O device assignments to be directly reported to the VMM (Virtual Memory Management) through the DMAR ACPI tables. This feature offers fully-protected I/O resource-sharing across the Intel platforms, providing the user with greater reliability, security and availability in networking and data-sharing. The settings are **Enable** and Disable.

PPIN Control

Select Unlock/Enable to use the Protected-Processor Inventory Number (PPIN) in the system. The options are **Unlock/Enable** and Unlock/Disable.

Hardware Prefetcher (Available when supported by the CPU)

If this feature is set to Enable, the hardware prefetcher will prefetch streams of data and instructions from the main memory to the Level 2 (L2) cache to improve CPU performance. The options are Disable and **Enable**.

Adjacent Cache Prefetch (Available when supported by the CPU)

Select Enable for the CPU to prefetch both cache lines for 128 bytes as comprised. Select Disable for the CPU to prefetch both cache lines for 64 bytes. The options are Disable and **Enable**.

Note: Please power off and reboot the system for the changes you've made to take effect. Please refer to Intel's website for detailed information.

DCU Streamer Prefetcher (Available when supported by the CPU)

If this item is set to Enable, the DCU (Data Cache Unit) streamer prefetcher will prefetch data streams from the cache memory to the DCU (Data Cache Unit) to speed up data accessing and processing for CPU performance enhancement. The options are Disable and **Enable**.

DCU IP Prefetcher

If this item is set to Enable, the IP prefetcher in the DCU (Data Cache Unit) will prefetch IP addresses to improve network connectivity and system performance. The options are **Enable** and Disable.

LLC Prefetch

If this feature is set to Enable, LLC (hardware cache) prefetching on all threads will be supported. The options are **Disable** and Enable.

Extended APIC (Extended Advanced Programmable Interrupt Controller)

Based on the Intel Hyper-Threading technology, each logical processor (thread) is assigned 256 APIC IDs (APIDs) in 8-bit bandwidth. When this feature is set to Enable, the APIC ID will be expanded from 8 bits to 16 bits to provide 512 APIDs to each thread to enhance CPU performance. The options are **Disable** and Enable.

AES-NI

Select Enable to use the Intel Advanced Encryption Standard (AES) New Instructions (NI) to ensure data security. The options are **Enable** and Disable.

► Advanced Power Management Configuration**Power Technology**

This feature allows the user to select the desired CPU Power Management profile. The options are Disable, **Energy Efficient**, and Custom.

► CPU P State Control**SpeedStep (PStates)**

EIST (Enhanced Intel SpeedStep Technology) allows the system to automatically adjust processor voltage and core frequency in an effort to reduce power consumption and heat dissipation. Please refer to Intel's website for detailed information. The options are Disable and **Enable**.

EIST PSD Function (Available when SpeedStep is set to Enable)

Use this item to configure the processor's P-State coordination settings. During a P-State, the voltage and frequency of the processor will be reduced when it is in operation. This makes the processor more energy efficient, resulting in further energy gains. The options are **HW_ALL**, **SW_ALL** and **SW-ANY**.

Turbo Mode (Available when SpeedStep is set to Enable)

Select Enable for processor cores to run faster than the frequency specified by the manufacturer. The options are Disable and **Enable**.

► Hardware PM (Power Management) State Control**Hardware P-States**

If this feature is set to Disable, hardware will choose a P-state setting for the system based on an OS request. If this feature is set to Native Mode, hardware will choose a P-state setting based on OS guidance. If this feature is set to Native Mode with No Legacy Support, hardware will choose a P-state setting independently without OS guidance. The options are **Disable**, Native Mode, Out of Band Mode, and Native Mode with No Legacy Support.

► CPU C State Control

Autonomous Core C-State

Select Enable to support Autonomous Core C-State control which will allow the processor core to control its C-State setting automatically and independently. The options are Enable and **Disable**.

CPU C6 Report

Select Enable to allow the BIOS to report the CPU C6 state (ACPI C3) to the operating system. During the CPU C6 state, power to all caches is turned off. The options are **Auto**, Enable, and Disable.

Enhanced Halt State (C1E)

Select Enable to enable "Enhanced Halt State" support, which will significantly reduce the CPU's power consumption by minimizing CPU's clock cycles and reduce voltage during a "Halt State." The options are Disable and **Enable**.

► Package C State Control

Package C State

Use this feature to set the limit on the C-State package register. The options are C0/1 state, C2 state, C6 (non-Retention) state, C6 (Retention) state, No Limit, and **Auto**.

► CPU T State Control

Software Controlled T-States

Enabling this feature allows the OS to choose a T-State. The options are Enable and **Disable**.

► Chipset Configuration

Warning: Setting the wrong values in the following sections may cause the system to malfunction.

► North Bridge

This feature allows the user to configure the settings for the Intel North Bridge.

► UPI (Ultra Path Interconnect) Configuration

This section displays the following UPI General Configuration information:

- Number of CPU
- Number of IIO
- Current UPI Link Speed
- Current UPI Link Frequency
- UPI Global MMIO Low Base/Limit
- UPI Global MMIO High Base/Limit
- UPI PCI-E Configuration Base/Size

Degrade Precedence

Use this feature to select the degrading precedence option for Ultra Path Interconnect connections. Select Topology Precedent to degrade UPI features if system options are in conflict. Select Feature Precedent to degrade UPI topology if system options are in conflict. The options are **Topology Precedence** and Feature Precedence.

Link L0p Enable

Select Enable to enable Link L0p. The options are Disable, Enable, and **Auto**.

Link L1 Enable

Select Enable to enable Link L1 (Level 1 link). The options are Disable, Enable, and **Auto**.

IO Directory Cache

Select Enable for the IODC (I/O Directory Cache) to generate snoops instead of generating memory lockups for remote IIO (InvItoM) and/or WCiLF (Cores). Select Auto for the IODC to generate snoops (instead of memory lockups) for WCiLF (Cores). The options are Disable, **Auto**, Enable for Remote InvItoM Hybrid Push, InvItoM AllocFlow, Enable for Remote InvItoM Hybrid AllocNonAlloc, and Enable for Remote InvItoM and Remote WViLF.

SNC

Sub NUMA Clustering (SNC) is a feature that breaks up the Last Level Cache (LLC) into clusters based on address range. Each cluster is connected to a subset of the memory controller. Enabling SNC improves average latency and reduces memory access congestion to achieve higher performance. Select Auto for 1-cluster or 2-clusters depending on IMC interleave. Select Enable for Full SNC (2-clusters and 1-way IMC interleave). The options are **Disable**, Enable, and Auto.

XPT Prefetch

XPT Prefetch speculatively makes a copy to the memory controller of a read request being sent to the LLC. If the read request maps to the local memory address and the recent memory reads are likely to miss the LLC, a speculative read is sent to the local memory controller. The options are **Disable** and Enable.

KTI Prefetch

KTI Prefetch enables memory read to start early on a DDR bus, where the KTI Rx path will directly create a Memory Speculative Read command to the memory controller. The options are Disable and **Enable**.

Local/Remote Threshold

This feature allows the user to set the threshold for the Interrupt Request (IRQ) signal, which handles hardware interruptions. The features are Disable, Enable, **Auto**, Low, Medium, and High.

Stale AtoS

This feature optimizes A to S directory. When all snoop responses found in directory A are found to be RspI, then all data is moved to directory S and is returned in S-state. The options are **Disable**, Enable, and Auto.

LLC dead line alloc

Select Enable to optimally fill dead lines in LLC. Select Disable to never fill dead lines in LLC. The options are Disable, **Enable**, and Auto.

Isoc Mode

Select Enable to enable Isochronous support to meet QoS (Quality of Service) requirements. This feature is especially important for Virtualization Technology. The options are Disable, Enable, and **Auto**.

► Memory Configuration

Enforce POR

Select POR to enforce POR restrictions for DDR4 memory frequency and voltage programming. The options are **POR** and Disable.

Memory Frequency

Use this feature to set the maximum memory frequency for onboard memory modules. The options are **Auto**, 1866, 2000, 2133, 2200, 2400, 2600, and 2666.

Data Scrambling for NVDIMM

Select Enable to enable data scrambling for onboard NVDIMM memory to enhance system performance and security. The options are **Auto**, Disable, and Enable.

Data Scrambling for DDR4

Select Enable to enable data scrambling for DDR4 memory to enhance system performance and security. The options are **Auto**, Disable, and Enable.

tCCD_L Relaxation

If this feature is set to Enable, SPD (Serial Presence Detect) will override tCCD_L ("Column to Column Delay-Long", or "Command to Command Delay-Long" on the column side.) If this feature is set to Disable, tCCD_L will be enforced based on the memory frequency. The options are Enable and **Disable**.

Enable ADR

Select Enable for ADR (Automatic Diagnostic Repository) support to enhance memory performance. The options are Enable and **Disable**.

2X REFRESH

This option allows the user to select 2X refresh mode. The options are **Auto**, Enabled, and Disabled.

Page Policy

This feature allows the user to determine the desired page mode for IMC. When **Auto** is selected, the memory controller will close or open pages based on the current operation. Closed policy closes that page after reading or writing. Adaptive is similar to open page policy, but can be dynamically modified. The default is **Auto**.

IMC Interleaving

This feature allows the user to configure Integrated Memory Controller (IMC) Interleaving settings. The options are **Auto**, 1-way Interleave, and 2-way Interleave.

► Memory Topology

This item displays the information of onboard memory modules as detected by the BIOS (such as P1 DIMMA1, P1 DIMMB1, and so on).

► Memory RAS (Reliability_Availability_Serviceability) Configuration

Use this submenu to configure the following Memory RAS settings.

Static Virtual Lockstep Mode

Select Enable to support Static Virtual Lockstep mode to enhance memory performance. The options are Enable and **Disable**.

Mirror Mode

Select Enable to set all 1LM/2LM memory installed in the system on the mirror mode, which will create a duplicate copy of data stored in the memory to increase memory security, but it will reduce the memory capacity into half. The options are Enable and **Disable**.

Memory Rank Sparing

Select Enable to support memory-rank sparing to optimize memory performance. The options are Enable and **Disable**.

Note: This item will not be available when memory mirror mode is enabled.

Correctable Error Threshold

Use this item to enter the threshold value for correctable memory errors. The default setting is 10.

SDDC Plus One

Select Enable for SDDC (Single Device Data Correction) support, which will increase the reliability and serviceability of your system memory. The options are Enable and **Disable**.

ADDDC (Adaptive Double Device Data Correction) Sparing

Select Enable for ADDDC sparing support to enhance memory performance. The options are Enable and **Disable**.

Patrol Scrub

Patrol Scrubbing is a process that allows the CPU to correct correctable memory errors detected in a memory module and send the corrections to the requestor (the original source). When this item is set to Enable, the IO hub will read and write back one cache line every 16K cycles if there is no delay caused by internal processing. By using this method, roughly 64 GB of memory behind the IO hub will be scrubbed every day. The options are **Enable** and Disable.

Patrol Scrub Interval

Use this item to specify the number of hours (between 0 to 24) required for the system to complete a full patrol scrubbing. Enter 0 for patrol scrubbing to be performed automatically. The default setting is **24**.

Note: This item is hidden when Patrol Scrub item is set to Disable.

► IIO Configuration

► CPU1 Configuration

IOU0 (IIO PCIe Br1)

This item configures the PCI-E port Bifuraction setting for a PCI-E port specified by the user. The options are x4x4x4x4, x4x4x8, x8x4x4, x8x8, x16, and **Auto**.

IOU1 (IIO PCIe Br2)

This item configures the PCI-E port Bifuraction setting for a PCI-E port specified by the user. The options are x4x4x4x4, x4x4x8, x8x4x4, x8x8, x16, and **Auto**.

IOU2 (IIO PCIe Br3)

This item configures the PCI-E port Bifuraction setting for a PCI-E port specified by the user. The options are x4x4x4x4, x4x4x8, x8x4x4, x8x8, x16, and Auto.

MCP0 (IIO PCIe Br4)

This item configures the PCI-E port Bifuraction setting for a PCI-E port specified by the user. The options are x4x4x4x4, x4x4x8, x8x4x4, x8x8, x16, and Auto.

MCP1 (IIO PCIe Br5)

This item configures the PCI-E port Bifuraction setting for a PCI-E port specified by the user. The options are x4x4x4x4, x4x4x8, x8x4x4, x8x8, x16, and Auto.

► CPU1 PcieBr0D00F0 - Port 0/DMI PcieBr1D00F0 - Port 1A PcieBr2D00F0 - Port 2A PcieBr3D00F0 - Port 3A PcieBr4D00F0 - MCP 0 PcieBr5D00F0 - MCP 1

Link Speed

Use this item to select the link speed for the PCI-E port specified by the user. The options are Auto, Gen 1 (2.5 GT/s), Gen 2 (5 GT/s), and Gen 3 (8 GT/s).

PCI-E Port Max Payload Size

Selecting Auto for this feature will enable the motherboard to automatically detect the maximum Transaction Layer Packet (TLP) size for the connected PCI-E device, allowing for maximum I/O efficiency. Selecting 128B or 256B will designate maximum packet size of 128 or 256. Options are Auto, 128, and 256. Auto is enabled by default.

►CPU2 Configuration

IOU0 (II0 PCIe Br1)

This item configures the PCI-E port Bifurcation setting for a PCI-E port specified by the user. The options are x4x4x4x4, x4x4x8, x8x4x4, x8x8, x16, and **Auto**.

IOU1 (II0 PCIe Br2)

This item configures the PCI-E port Bifurcation setting for a PCI-E port specified by the user. The options are x4x4x4x4, x4x4x8, x8x4x4, x8x8, x16, and **Auto**.

IOU2 (II0 PCIe Br3)

This item configures the PCI-E port Bifurcation setting for a PCI-E port specified by the user. The options are x4x4x4x4, x4x4x8, x8x4x4, x8x8, x16, and **Auto**.

MCP0 (II0 PCIe Br4)

This item configures the PCI-E port Bifurcation setting for a PCI-E port specified by the user. The options are x4x4x4x4, x4x4x8, x8x4x4, x8x8, x16, and **Auto**.

MCP1 (II0 PCIe Br5)

This item configures the PCI-E port Bifurcation setting for a PCI-E port specified by the user. The options are x4x4x4x4, x4x4x8, x8x4x4, x8x8, x16, and **Auto**.

►CPU2 PcieBr1D00F0 - Port 1A/Socket 1 PcieBr2D00F0 - Port 2A/Socket 1 PcieBr3D00F0 - Port 3A/Socket 1 PcieBr4D00F0 - MCP 0/Socket 1 PcieBr5D00F0 - MCP 1

Link Speed

Use this item to select the link speed for the PCI-E port specified by the user. The options are **Auto**, Gen 1 (2.5 GT/s), Gen 2 (5 GT/s), and Gen 3 (8 GT/s).

PCI-E Port Max Payload Size

Selecting **Auto** for this feature will enable the motherboard to automatically detect the maximum Transaction Layer Packet (TLP) size for the connected PCI-E device, allowing for maximum I/O efficiency. Selecting 128B or 256B will designate maximum packet size of 128 or 256. Options are **Auto**, 128, and 256. **Auto** is enabled by default.

► IOAT Configuration

Disable TPH (TLP Processing Hint)

TPH is used for data-tagging with a destination ID and a few important attributes. It can send critical data to a particular cache without writing through to memory. Select No in this item for TLP Processing Hint support, which will allow a "TLP request" to provide "hints" to help optimize the processing of each transaction occurred in the target memory space. The options are Yes and **No**.

Prioritize TPH (TLP Processing Hint)

Select Yes to prioritize the TLP requests that will allow the "hints" to be sent to help facilitate and optimize the processing of certain transactions in the system memory. The options are Enable and **Disable**.

Relaxed Ordering

Select Enable to enable Relaxed Ordering support which will allow certain transactions to violate the strict-ordering rules of PCI and to be completed prior to other transactions that have already been enqueued. The options are **Disable** and Enable.

► Intel VT for Directed I/O (VT-d)

Intel® VT for Directed I/O (VT-d)

Intel® VT for Directed I/O (VT-d)

Select Enable to use Intel Virtualization Technology support for Direct I/O VT-d by reporting the I/O device assignments to the VMM (Virtual Machine Monitor) through the DMAR ACPI tables. This feature offers fully-protected I/O resource sharing across Intel platforms, providing greater reliability, security and availability in networking and data-sharing. The options are **Enable** and Disable.

Interrupt Remapping

Select Enable for Interrupt Remapping support to enhance system performance. The options are **Enable** and Disable.

PassThrough DMA

Select Enable for the Non-IscoH VT-d engine to pass through DMA (Direct Memory Access) to enhance system performance. The options are **Enable** and Disable.

ATS

Select Enable to enable ATS (Address Translation Services) support for the Non-IscoH VT-d engine to enhance system performance. The options are **Enable** and Disable.

Posted Interrupt

Select Enable to support VT_D Posted Interrupt which will allow external interrupts to be sent directly from a direct-assigned device to a client machine in non-root mode to improve virtualization efficiency by simplifying interrupt migration and lessening the need of physical interrupts. The options are **Enable** and Disable.

Coherency Support (Non-IscoH)

Select Enable for the Non-IscoH VT-d engine to pass through DMA (Direct Memory Access) to enhance system performance. The options are **Enable** and Disable.

► Intel® VMD Technology**► Intel® VMD for Volume Management Device on CPU1****VMD Config for PStack0****Intel® VMD for Volume Management Device**

Select Enable to use the Intel Volume Management Device Technology for this stack. The options are **Disable** and Enable.

****If the item "Intel VMD for Volume Management Device" above is set to Enable, the following items will be displayed:***

CPU SLOT6 PCI-E 3.0 X8 VMD (Available when the device is detected by the system)

Select Enable to use the Intel Volume Management Device Technology for this specific root port. The options are **Disable** and Enable.

CPU SLOT4 PCI-E 3.0 X8 VMD (Available when the device is detected by the system)

Select Enable to use the Intel Volume Management Device Technology for this specific root port. The options are **Disable** and Enable.

Hot Plug Capable (Available when the device is detected by the system)

Use this feature to enable hot plug support for PCIe root ports 1A~1D. The options are **Disable** and Enable.

VMD Config for PStack1**Intel® VMD for Volume Management Device**

Select Enable to use the Intel Volume Management Device Technology for this stack. The options are **Disable** and Enable.

**If the item "Intel VMD for Volume Management Device" above is set to Enable, the following items will be displayed:*

CPU SLOT5 PCI-E 3.0 X16 VMD (Available when the device is detected by the system)

Select Enable to use the Intel Volume Management Device Technology for this specific root port. The options are **Disable** and Enable.

Hot Plug Capable (Available when the device is detected by the system)

Select Enable to enable hot plug support for PCIe root ports 2A~2D. The options are **Disable** and Enable.

VMD Config for PStack2**Intel® VMD for Volume Management Device**

Select Enable to use the Intel Volume Management Device Technology for this stack. The options are **Disable** and Enable.

**If the item "Intel VMD for Volume Management Device" above is set to Enable, the following items will be displayed:*

CPU SLOT2 PCI-E 3.0 X8 VMD (Available when the device is detected by the system)

Select Enable to use the Intel Volume Management Device Technology for this specific root port. The options are **Disable** and Enable.

CPU SLOT1 PCI-E 3.0 X4 VMD (Available when the device is detected by the system)

Select Enable to use the Intel Volume Management Device Technology for this specific root port. The options are **Disable** and Enable.

Hot Plug Capable (Available when the device is detected by the system)

Select Enable to enable hot plug support for PCIe root ports 3A~3D. This will allow the user to replace the components without shutting down the system. The options are **Disable** and Enable.

► **Intel® VMD for Volume Management Device on CPU2**

VMD Config for PStack2

Intel® VMD for Volume Management Device

Select Enable to use the Intel Volume Management Device Technology for this stack. The options are **Disable** and Enable.

**If the item "Intel VMD for Volume Management Device" above is set to Enable, the following items will be displayed:*

CPU SLOT3 PCI-E 3.0 X16 VMD (Available when the device is detected by the system)

Select Enable to enable hot plug support for the Intel Volume Management Device Technology for this specific root port. The options are **Disable** and Enable.

Hot Plug Capable (Available when the device is detected by the system)

Use this feature to enable hot plug support for PCIe root ports 3A~3D. The options are **Disable** and Enable.

IIO-PCIE Express Global Options

PCI-E Completion Timeout Disable

Select Enable to enable PCI-E Completion Timeout support for electric tuning. The options are Yes, **No**, and Per-Port.

► **South Bridge**

The following South Bridge information will display:

- USB Module Version
- USB Devices

Legacy USB Support

Select Enabled to support onboard legacy USB devices. Select Auto to disable legacy support if there are no legacy USB devices present. Select Disable to have all USB devices available for EFI applications only. The options are Enabled, Disabled and Auto.

XHCI Hand-Off

This is a work-around solution for operating systems that do not support XHCI (Extensible Host Controller Interface) hand-off. The XHCI ownership change should be claimed by the XHCI driver. The options are Enabled and **Disabled**.

Port 60/64 Emulation

Select Enabled for I/O port 60h/64h emulation support, which in turn, will provide complete legacy USB keyboard support for the operating systems that do not support legacy USB devices. The options are **Enabled** and Disabled.

► Server ME (Management Engine) Configuration

This feature displays the following system ME configuration settings.

Operational Firmware Version

Backup Firmware Version

Recovery Firmware Version

ME Firmware Status #1

ME Firmware Status #2

 Current State

 Error Code

► PCH SATA Configuration

When this submenu is selected, the AMI BIOS automatically detects the presence of the SATA devices that are supported by the Intel PCH chip and displays the following items:

SATA Controller

This item enables or disables the onboard SATA controller supported by the Intel PCH chip. The options are **Enable** and Disable.

Configure SATA as (Available when the item above: SATA Controller is set to enabled)

Select AHCI to configure a SATA drive specified by the user as an AHCI drive. Select RAID to configure a SATA drive specified by the user as a RAID drive. The options are **AHCI** and RAID. (**Note:** This item is hidden when the SATA Controller item is set to Disabled.)

SATA HDD Unlock

Select Enable to unlock SATA HDD password in the OS. The options are **Enable** and Disable.

SATA/sSATA RAID Boot Select (Available when the item "Configure SATA as" is set to "RAID")

This feature allows the user to decide which controller should be used for system boot. The options are None, SATA Controller, **sSATA Controller**, and Both.

Aggressive Link Power Management

When this item is set to Enabled, the SATA AHCI controller manages the power use of the SATA link. The controller will put the link in a low power mode during an extended period of I/O inactivity, and will return the link to an active state when I/O activity resumes. The options are Enable and **Disable**.

SATA RAID Option ROM/UEFI Driver (Available when the item "Configure SATA as" is set to "RAID")

Select EFI to load the EFI driver for system boot. Select Legacy to load a legacy driver for system boot. The options are Disable, EFI, and **Legacy**.

SATA Port 0 - SATA Port 7**Hot Plug**

Select Enable to support Hot-plugging for the device installed on a selected SATA port which will allow the user to replace the device installed in the slot without shutting down the system. The options are Enable and **Disable**.

Spin Up Device

On an edge detect from 0 to 1, set this item to allow the SATA device installed on the SATA port specified by the user to start a COMRESET initialization. The options are Enable and **Disable**.

SATA Device Type

Use this item to specify if the device installed on the SATA port selected by the user should be connected to a Solid State drive or a Hard Disk Drive. The options are **Hard Disk Drive** and Solid State Drive.

► PCH sSATA Configuration

When this submenu is selected, AMI BIOS automatically detects the presence of the sSATA devices that are supported by the sSATA controller and displays the following items:

sSATA Controller

This item enables or disables the onboard sSATA controller supported by the Intel SCU. The options are **Enable** and Disable.

Configure sSATA as

Select AHCI to configure an sSATA drive specified by the user as an AHCI drive. Select RAID to configure an sSATA drive specified by the user as a RAID drive. The options are **AHCI** and RAID. (**Note:** This item is hidden when the sSATA Controller item is set to Disabled.)

SATA HDD Unlock

Select Enable to unlock sSATA HDD password in the OS. The options are **Enable** and Disable.

SATA/sSATA RAID Boot Select (Available when the item "Configure SATA as" is set to "RAID")

This feature allows the user to decide which controller should be used for system boot. The options are None, SATA Controller, **sSATA Controller**, and Both.

Support Aggressive Link Power Management

When this item is set to Enable, the sSATA AHCI controller manages the power use of the SATA link. The controller will put the link in a low power mode during an extended period of I/O inactivity, and will return the link to an active state when I/O activity resumes. The options are **Disable** and Enable.

sSATA RAID Option ROM/UEFI Driver (Available when the item "Configure SATA as" is set to "RAID")

Select EFI to load the EFI driver for system boot. Select Legacy to load a legacy driver for system boot. The options are Disable, EFI, and **Legacy**.

sSATA Port 0 - sSATA Port 5**Hot Plug**

Select Enable to support Hot-plugging for the device installed on an sSATA port selected by the user which will allow the user to replace the device installed in the slot without shutting down the system. The options are **Disable** and Enabled.

Spin Up Device

On an edge detect from 0 to 1, set this item to allow the sSATA device installed on the sSATA port specified by the user to start a COMRESET initialization. The options are Enable and **Disable**.

sSATA Device Type

Use this item to specify if the device installed on the sSATA port specified by the user should be connected to a Solid State drive or a Hard Disk Drive. The options are Hard Disk Drive and Solid State Drive.

► PCIe/PCI/PnP Configuration

The following PCI information will be displayed:

PCI Bus Driver Version

PCI Devices Common Settings:

Above 4G Decoding (Available if the system supports 64-bit PCI decoding)

Select Enabled to decode a PCI device that supports 64-bit in the space above 4G Address. The options are **Enabled** and Disabled.

SR-IOV Support (Available if the system supports Single-Root Virtualization)

Select Enabled for Single-Root IO Virtualization support. The options are Enabled and **Disabled**.

MMIOHBase

Use this item to select the base memory size according to memory-address mapping for the IO hub. The base memory size must be between 4032G to 4078G. The options are **56T**, 48T, 24T, 16T, 4T, and 1T.

MMIO High Granularity Size

Use this item to select the high memory size according to memory-address mapping for the IO hub. The options are 1G, 4G, 16G, 64G, **256G**, and 1024G.

PCI PERR/SERR Support

Use this feature to enable or disable the runtime event for SERR (System Error)/ PERR (PCI/PCI-E Parity Error). The options are Disabled and **Enabled**.

Maximum Read Request

Select Auto for the system BIOS to automatically set the maximum size for a read request for a PCI-E device to enhance system performance. The options are **Auto**, 128 Bytes, 256 Bytes, 512 Bytes, 1024 Bytes, 2048 Bytes, and 4096 Bytes.

MMCFG Base

This feature determines the lowest MMCFG (Memory-Mapped Configuration) base assigned to PCI devices. The options are 1G, 1.5G, 1.75G, **2G**, 2.25G, and 3G.

NVMe Firmware Source

Use this item to select the NVMe firmware to support system boot. The options are **Vendor Defined Firmware** and AMI Native Support. The default option, Vendor Defined Firmware, is pre-installed on the drive and may resolve errata or enable innovative functions for the drive. The other option, AMI Native Support, is offered by the BIOS with a generic method.

VGA Priority

Use this item to select the graphics device to be used as the primary video display for system boot. The options are Auto, **Onboard** and Offboard.

M.2 PCI-E 3.0 x4 OPROM

Select Enabled to enable Option ROM support to boot the computer using a device installed on the slot specified by the user. The options are Disabled, Legacy and EFI. Use this feature to select which firmware type to be loaded for the add-on card in this slot. The options are Disabled, **Legacy**, and EFI.

CPU1 PCI-E 3.0 x16/1U Riser OPROM

Use this feature to select which firmware type to be loaded for the add-on card in this slot. The options are Disabled, **Legacy**, and EFI.

CPU1 JSXB2 PCI-E 3.0 x8 OPROM

Use this feature to select which firmware type to be loaded for the add-on card in this slot. The options are Disabled, **Legacy**, and EFI.

CPU2 JSXB2 PCI-E 3.0 x8 OPROM

Use this feature to select which firmware type to be loaded for the add-on card in this slot. The options are Disabled, **Legacy**, and EFI.

SIOM: CPU1 PCI-E 3.0 x16 OPROM

Use this feature to select which firmware type to be loaded for the add-on card in this slot. The options are Disabled, **Legacy**, and EFI.

SIOM: CPU1 PCI-E 3.0 x8 OPROM

Use this feature to select which firmware type to be loaded for the add-on card in this slot. The options are Disabled, **Legacy**, and EFI.

CPU2 JSXB3 PCI-E 3.0 x16 OPROM

Use this feature to select which firmware type to be loaded for the add-on card in this slot. The options are Disabled, **Legacy**, and EFI.

Onboard SAS Option ROM

Use this feature to select which firmware function to be loaded for LAN Port1 used for system boot. The options are Disabled, **Legacy**, and EFI.

Onboard NVMe1 Option ROM

Use this feature to select which firmware function to be loaded for NVMe1 used for system boot. The options are Disabled, Legacy, and **EFI**.

Onboard NVMe2 Option ROM

Use this feature to select which firmware function to be loaded for NVMe2 used for system boot. The options are Disabled, Legacy, and **EFI**.

Onboard NVMe3 Option ROM

Use this feature to select which firmware function to be loaded for NVMe2 used for system boot. The options are Disabled, Legacy, and **EFI**.

Onboard NVMe4 Option ROM

Use this feature to select which firmware function to be loaded for NVMe2 used for system boot. The options are Disabled, Legacy, and **EFI**.

Onboard Video Option ROM

Use this item to select the Onboard Video Option ROM type. The options are Disabled, Legacy, and EFI.

► Network Stack Configuration**Network Stack**

Select Enabled to enable PXE (Preboot Execution Environment) or UEFI (Unified Extensible Firmware Interface) for network stack support. The options are **Enabled** and Disabled.

**If "Network Stack" is set to Enabled, the following items will display:*

Ipv4 PXE Support

Select Enabled to enable Ipv4 PXE boot support. If this feature is disabled, it will not create the Ipv4 PXE boot option. The options are Disabled and **Enabled**.

Ipv4 HTTP Support

Select Enabled to enable Ipv4 HTTP boot support. If this feature is disabled, it will not create the Ipv4 HTTP boot option. The options are Enabled and **Disabled**.

Ipv6 PXE Support

Select Enabled to enable Ipv6 PXE boot support. If this feature is disabled, it will not create the Ipv6 PXE boot option. The options are Disabled and **Enabled**.

Ipv6 HTTP Support

Select Enabled to enable Ipv6 HTTP boot support. If this feature is disabled, it will not create the Ipv6 HTTP boot option. The options are Enabled and **Disabled**.

PXE Boot Wait Time

Use this feature to select the wait time to press the <ESC> key to abort the PXE boot. The default is **0**.

Media Detect count

Use this feature to select the wait time in seconds for the BIOS ROM to detect the LAN media (Internet connection or LAN port). The default is 1.

► Super IO Configuration

Super IO Chip AST2500

► Serial Port 1 Configuration

Serial Port

Select Enabled to enable the onboard serial port specified by the user. The options are **Enabled** and Disabled.

Device Settings

This item displays the base I/O port address and the Interrupt Request address of a serial port specified by the user.

Note: This item is hidden when Serial Port 1 is set to Disabled.

Change Settings

This feature specifies the base I/O port address and the Interrupt Request address of Serial Port 1. Select **Auto** for the BIOS to automatically assign the base I/O and IRQ address to a serial port specified.

The options for Serial Port 1 are **Auto**, (IO=3F8h; IRQ=4), (IO=3F8h; IRQ=3, 4, 5, 6, 7, 9, 10, 11, 12), (IO=2F8h; IRQ=3, 4, 5, 6, 7, 9, 10, 11, 12); (IO=3E8h; IRQ=3, 4, 5, 6, 7, 9, 10, 11, 12), and (IO=2E8h; IRQ=3, 4, 5, 6, 7, 9, 10, 11, 12).

► Serial Port 2 Configuration

Serial Port

Select Enabled to enable the onboard serial port specified by the user. The options are **Enabled** and Disabled.

Device Settings

This item displays the base I/O port address and the Interrupt Request address of a serial port specified by the user.

Note: This item is hidden when Serial Port 1 is set to Disabled.

Change Settings

This feature specifies the base I/O port address and the Interrupt Request address of Serial Port 2. Select Auto for the BIOS to automatically assign the base I/O and IRQ address to a serial port specified. The options for Serial Port 2 are **Auto**, (IO=2F8h; IRQ=3), (IO=3F8h; IRQ=3, 4, 5, 6, 7, 9, 10, 11, 12), (IO=2F8h; IRQ=3, 4, 5, 6, 7, 9, 10, 11, 12); (IO=3E8h; IRQ=3, 4, 5, 6, 7, 9, 10, 11, 12), and (IO=2E8h; IRQ=3, 4, 5, 6, 7, 9, 10, 11, 12).

Serial Port 2 Attribute

Select SOL to use COM Port 2 as a Serial_Over_LAN (SOL) port for console redirection. The options are COM and **SOL**.

► Serial Port Console Redirection

COM 1 Console Redirection

Select Enabled to enable COM Port 1 for Console Redirection, which will allow a client machine to be connected to a host machine at a remote site for networking. The options are Enabled and **Disabled**.

**If the item above set to Enabled, the following items will become available for configuration:*

► Console Redirection Settings (for COM1)

Terminal Type

Use this feature to select the target terminal emulation type for Console Redirection. Select VT100 to use the ASCII Character set. Select VT100+ to add color and function key support. Select ANSI to use the Extended ASCII Character Set. Select VT-UTF8 to use UTF8 encoding to map Unicode characters into one or more bytes. The options are ANSI, VT100, **VT100+**, and VT-UTF8.

Bits Per second

Use this feature to set the transmission speed for a serial port used in Console Redirection. Make sure that the same speed is used in the host computer and the client computer. A lower transmission speed may be required for long and busy lines. The options are 9600, 19200, 38400, 57600 and **115200** (bits per second).

Data Bits

Use this feature to set the data transmission size for Console Redirection. The options are 7 (Bits) and **8 (Bits)**.

Parity

A parity bit can be sent along with regular data bits to detect data transmission errors. Select Even if the parity bit is set to 0, and the number of 1's in data bits is even. Select Odd if the parity bit is set to 0, and the number of 1's in data bits is odd. Select None if you do not want to send a parity bit with your data bits in transmission. Select Mark to add a mark as a parity bit to be sent along with the data bits. Select Space to add a Space as a parity bit to be sent with your data bits. The options are **None**, Even, Odd, Mark and Space.

Stop Bits

A stop bit indicates the end of a serial data packet. Select 1 Stop Bit for standard serial data communication. Select 2 Stop Bits if slower devices are used. The options are **1** and 2.

Flow Control

Use this feature to set the flow control for Console Redirection to prevent data loss caused by buffer overflow. Send a "Stop" signal to stop sending data when the receiving buffer is full. Send a "Start" signal to start sending data when the receiving buffer is empty. The options are **None** and Hardware RTS/CTS.

VT-UTF8 Combo Key Support

Select Enabled to enable VT-UTF8 Combination Key support for ANSI/VT100 terminals. The options are **Enabled** and Disabled.

Recorder Mode

Select Enabled to capture the data displayed on a terminal and send it as text messages to a remote server. The options are **Disabled** and Enabled.

Resolution 100x31

Select Enabled for extended-terminal resolution support. The options are Disabled and **Enabled**.

Legacy OS Redirection Resolution

Use this feature to select the number of rows and columns used in Console Redirection for legacy OS support. The options are **80x24** and 80x25.

Putty KeyPad

This feature selects Function Keys and KeyPad settings for Putty, which is a terminal emulator designed for the Windows OS. The options are **VT100**, LINUX, XTERMR6, SCO, ESCN, and VT400.

Redirection After BIOS Post

Use this feature to enable or disable legacy Console Redirection after BIOS POST. When the option-Bootloader is selected, legacy Console Redirection is disabled before booting the OS. When the option-Always Enable is selected, legacy Console Redirection remains enabled upon OS bootup. The options are **Always Enable** and Bootloader.

SOL (Serial-Over-LAN)/COM2

Console Redirection (for SOL/COM2)

Select Enabled to use the SOL port for Console Redirection. The options are **Enabled** and Disabled.

**If the item above set to Enabled, the following items will become available for user's configuration:*

► Console Redirection Settings (for SOL/COM2)

Use this feature to specify how the host computer will exchange data with the client computer, which is the remote computer used by the user.

Terminal Type

Use this feature to select the target terminal emulation type for Console Redirection. Select VT100 to use the ASCII Character set. Select VT100+ to add color and function key support. Select ANSI to use the Extended ASCII Character Set. Select VT-UTF8 to use UTF8 encoding to map Unicode characters into one or more bytes. The options are ANSI, VT100, **VT100+**, and VT-UTF8.

Bits Per second

Use this feature to set the transmission speed for a serial port used in Console Redirection. Make sure that the same speed is used in the host computer and the client computer. A lower transmission speed may be required for long and busy lines. The options are 9600, 19200, 38400, 57600 and **115200** (bits per second).

Data Bits

Use this feature to set the data transmission size for Console Redirection. The options are 7 (Bits) and **8 (Bits)**.

Parity

A parity bit can be sent along with regular data bits to detect data transmission errors. Select Even if the parity bit is set to 0, and the number of 1's in data bits is even. Select Odd if the parity bit is set to 0, and the number of 1's in data bits is odd. Select None if you do not want to send a parity bit with your data bits in transmission. Select Mark to add a mark as a parity bit to be sent along with the data bits. Select Space to add a Space as a parity bit to be sent with your data bits. The options are **None**, Even, Odd, Mark and Space.

Stop Bits

A stop bit indicates the end of a serial data packet. Select 1 Stop Bit for standard serial data communication. Select 2 Stop Bits if slower devices are used. The options are **1** and 2.

Flow Control

Use this feature to set the flow control for Console Redirection to prevent data loss caused by buffer overflow. Send a "Stop" signal to stop sending data when the receiving buffer is full. Send a "Start" signal to start data-sending when the receiving buffer is empty. The options are **None** and Hardware RTS/CTS.

VT-UTF8 Combo Key Support

Select Enabled to enable VT-UTF8 Combination Key support for ANSI/VT100 terminals. The options are **Enabled** and Disabled.

Recorder Mode

Select Enabled to capture the data displayed on a terminal and send it as text messages to a remote server. The options are **Disabled** and Enabled.

Resolution 100x31

Select Enabled for extended-terminal resolution support. The options are Disabled and **Enabled**.

Legacy OS Redirection Resolution

Use this feature to select the number of rows and columns used in Console Redirection for legacy OS support. The options are **80x24** and 80x25.

Putty KeyPad

This feature selects Function Keys and KeyPad settings for Putty, which is a terminal emulator designed for the Windows OS. The options are **VT100**, LINUX, XTERMR6, SCO, ESCN, and VT400.

Redirection After BIOS Post

Use this feature to enable or disable legacy Console Redirection after BIOS POST (Power-On Self-Test). When this feature is set to Bootloader, legacy Console Redirection is disabled before booting the OS. When this feature is set to Always Enable, legacy Console Redirection remains enabled upon OS boot. The options are **Always Enable** and Bootloader.

► Legacy Console Redirection Settings

Legacy Console Redirection Settings

Use the feature to select the COM port to display redirection of Legacy OS and Legacy OPROM messages. The default setting is **COM1**.

Serial Port for Out-of-Band Management/Windows Emergency Management Services (EMS)

The submenu allows the user to configure Console Redirection settings to support Out-of-Band Serial Port management.

Console Redirection (for EMS)

Select Enabled to use a COM port selected by the user for EMS Console Redirection. The options are **Disabled** and Enabled.

**If the item above set to Enabled, the following items will become available for user's configuration:*

► EMS Console Redirection Settings

Out-of-Band Management Port

The feature selects a serial port in a client server to be used by the Windows Emergency Management Services (EMS) to communicate with a remote host server. The options are **COM1 (Console Redirection)** and COM2/SOL (Console Redirection).

Terminal Type

Use this feature to select the target terminal emulation type for Console Redirection. Select VT100 to use the ASCII character set. Select VT100+ to add color and function key support. Select ANSI to use the extended ASCII character set. Select VT-UTF8 to use UTF8 encoding to map Unicode characters into one or more bytes. The options are ANSI, VT100, VT100+, and **VT-UTF8**.

Bits Per Second

This feature sets the transmission speed for a serial port used in Console Redirection. Make sure that the same speed is used in both host computer and the client computer. A lower transmission speed may be required for long and busy lines. The options are 9600, 19200, 57600, and **115200** (bits per second).

Flow Control

Use this feature to set the flow control for Console Redirection to prevent data loss caused by buffer overflow. Send a "Stop" signal to stop data-sending when the receiving buffer is full. Send a "Start" signal to start data-sending when the receiving buffer is empty. The options are **None**, Hardware RTS/CTS, and Software Xon/Xoff.

The setting for each these features is displayed:

Data Bits, Parity, Stop Bits

► ACPI Settings

Use this feature to configure Advanced Configuration and Power Interface (ACPI) power management settings for your system.

NUMA Support (Available when the OS supports this feature)

Select Enabled to enable Non-Uniform Memory Access support to enhance system performance. The options are **Enabled** and Disabled.

WHEA Support

Select Enabled to support the Windows Hardware Error Architecture (WHEA) platform and provide a common infrastructure for the system to handle hardware errors within the Windows OS environment to reduce system crashes and to enhance system recovery and health monitoring. The options are **Enabled** and Disabled.

High Precision Timer

Select Enabled to activate the High Precision Event Timer (HPET) that produces periodic interrupts at a much higher frequency than a Real-time Clock (RTC) does in synchronizing multimedia streams, providing smooth playback and reducing the dependency on other timestamp calculation devices, such as an x86 RDTSC Instruction embedded in the CPU. The High Performance Event Timer is used to replace the 8254 Programmable Interval Timer. The options are **Enabled** and Disabled.

6.4 Trusted Computing

When a TPM (Trusted-Platform Module) device is detected in your machine, the following information will be displayed.

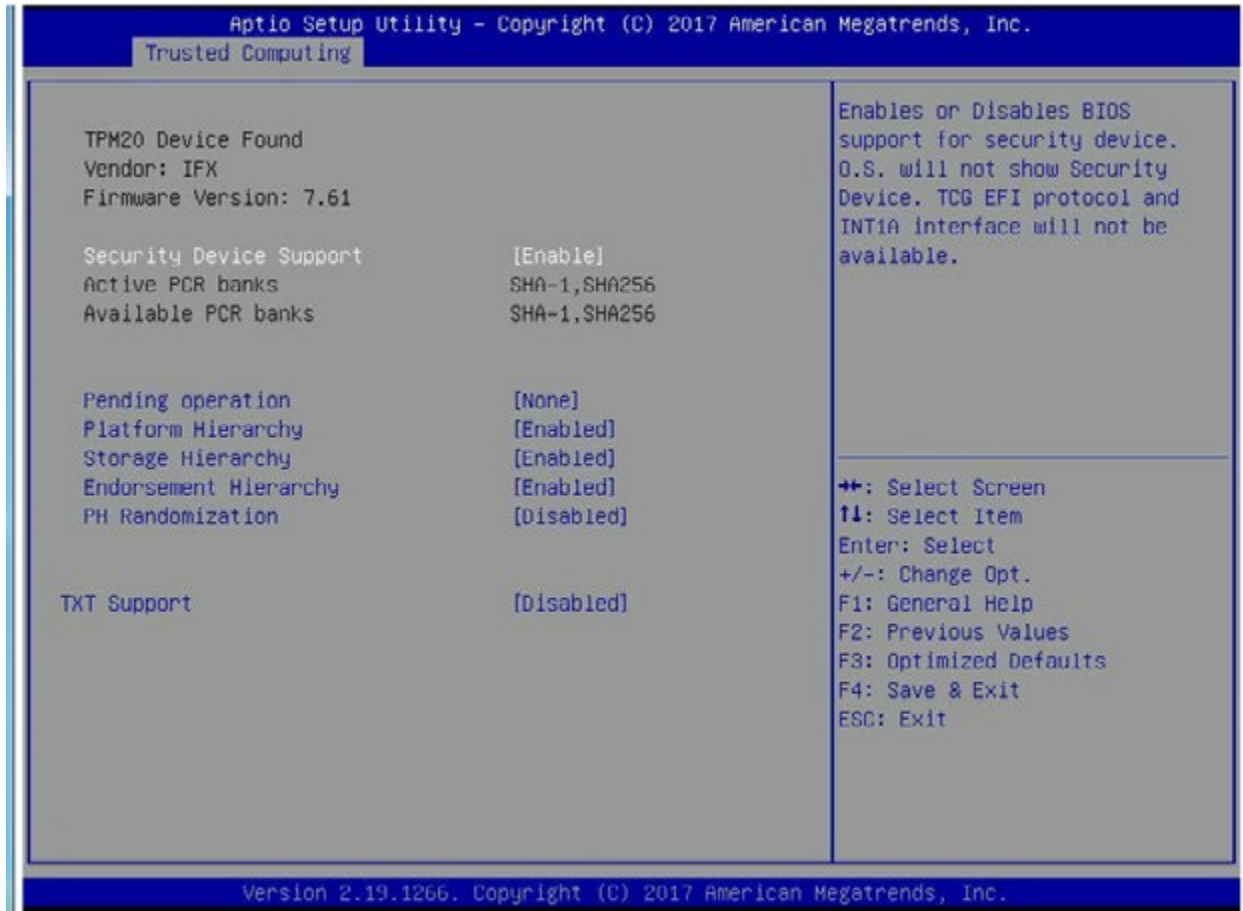

- TPM2.0 Device Found
- Vendor
- Firmware Version

Security Device Support

If this feature and the TPM jumper (JPT1) on the motherboard are both enabled, the onboard security (TPM) device will be enabled in the BIOS to enhance data integrity and system security. Please note that the OS will not show the security device. Neither TCG EFI protocol nor INT1A interaction will be made available for use. If you have made changes on the setting on this item, be sure to reboot the system for the change to take effect. The options are Disable and **Enable**. If this option is set to Enable, the following screen and items will display:

- Active PCR Banks
- Available PCR Banks

Pending Operation

Use this feature to schedule a TPM-related operation to be performed by a security (TPM) device at the next system boot to enhance system data integrity. Your system will reboot to carry out a pending TPM operation. The options are **None** and TPM Clear.

Note: Your system will reboot to carry out a pending TPM operation.

Platform Hierarchy (for TPM Version 2.0 and above)

Select Enabled for TPM Platform Hierarchy support which will allow the manufacturer to utilize the cryptographic algorithm to define a constant key or a fixed set of keys to be used for initial system boot. This early boot code is shipped with the platform and is included in the list of "public keys". During system boot, the platform firmware uses this trusted public key to verify a digital signature in an attempt to manage and control the security of the platform firmware used in a host system via a TPM device. The options are **Enabled** and Disabled.

Storage Hierarchy

Select Enabled for TPM Storage Hierarchy support that is intended to be used for non-privacy-sensitive operations by the platform owner such as an IT professional or the end user. Storage Hierarchy has an owner policy and an authorization value, both of which can be set and are held constant (-rarely changed) through reboots. This hierarchy can be cleared or changed independently of the other hierarchies. The options are **Enabled** and Disabled.

Endorsement Hierarchy

Select Enabled for Endorsement Hierarchy support, which contains separate controls to address the user's privacy concerns because the primary keys in this hierarchy are certified by the TPM or a manufacturer to be constrained to an authentic TPM device that is attached to an authentic platform. A primary key can be an encrypted, and a certificate can be created using TPM2_ActivateCredential. It allows the user to independently enable "flag, policy, and authorization value" without involving other hierarchies. A user with privacy concerns can disable the endorsement hierarchy while still using the storage hierarchy for TPM applications and permitting the platform software to use the TPM. The options are **Enabled** and Disabled.

PH (Platform Hierarchy) Randomization (for TPM Version 2.0 and above)

Select Enabled for Platform Hierarchy Randomization support, which is used only during the platform developmental stage. This feature cannot be enabled in the production platforms. The options are **Disabled** and Enabled.

TXT Support

Select Enabled to enable Intel Trusted Execution Technology (TXT) support to enhance system security and data integrity. The options are **Disabled** and Enabled.

Note 1: If the option for this item (TXT Support) is set to Enabled, be sure to disable EV DFX (Device Function On-Hide) support for the system to work properly. (EV DFX is under "I/O Configuration" in the "Chipset/North Bridge" submenu).

Note 2: For more information on TPM, please refer to the TPM manual at <http://www.supermicro.com/manuals/other>.

▶ **iSCSI Configuration**

iSCSI Initiator Name

This feature allows the user to enter the unique name of the iSCSI Initiator in IQN format. Once the name of the iSCSI Initiator is entered into the system, configure the proper settings for the following items.

- ▶ **Add an Attempt**

- ▶ **Delete Attempts**

- ▶ **Change Attempt Order**

▶ **Intel® Virtual RAID on CPU**

When this submenu is selected and the RAID devices are detected, the BIOS screen displays the following items:

Intel® VROC with VMD Technology 5.0.0.1205

6.5 Event Logs

Use this feature to configure Event Log settings.

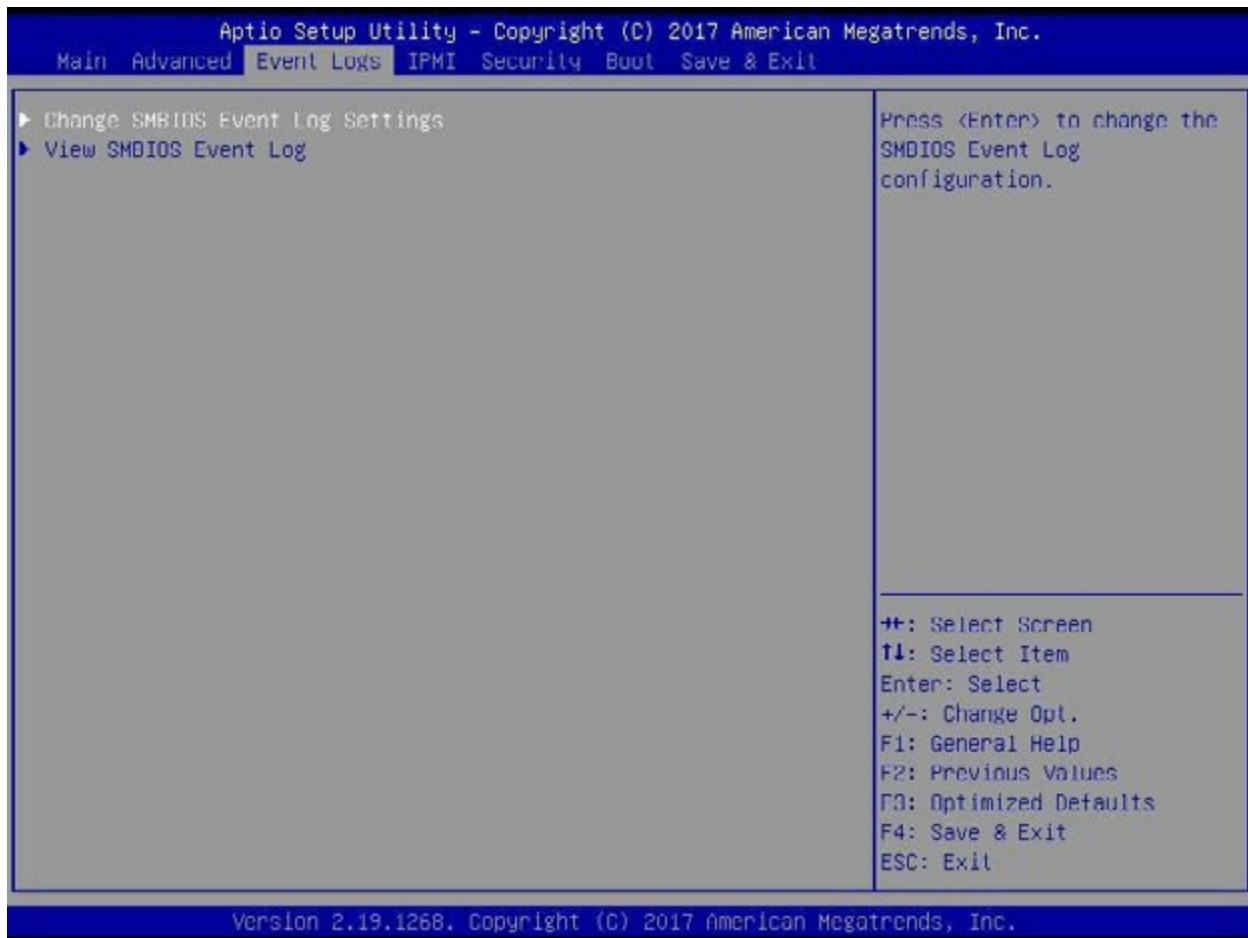

▶ Change SMBIOS Event Log Settings

Enabling/Disabling Options

SMBIOS Event Log

Select Enabled to enable SMBIOS (System Management BIOS) Event Logging during system boot. The options are **Enabled** and Disabled.

Erasing Settings

Erase Event Log

Select Enabled to erase all error events in the SMBIOS (System Management BIOS) log before an event logging is initialized at bootup. The options are **No**, Yes, Next Reset, and Yes, Next Reset.

When Log is Full

Select Erase Immediately to immediately erase all errors in the SMBIOS event log when the event log is full. Select Do Nothing for the system to do nothing when the SMBIOS event log is full. The options are **Do Nothing** and Erase Immediately.

SMBIOS Event Log Standard Settings

Log System Boot Event

Select Enabled to log system boot events. The options are Enabled and **Disabled**.

MECI (Multiple Event Count Increment)

Enter the increment value for the multiple event counter. Enter a number between 1 to 255. The default setting is 1.

METW (Multiple Event Count Time Window)

This item is used to determine how long (in minutes) should the multiple event counter wait before generating a new event log. Enter a number between 0 to 99. The default setting is **60**.

Note: Please reboot the system for the changes to take effect.

►View System Event Log

This item allows the user to view the event in the system event log. Select this item and press <Enter> to view the status of an event in the log. The following categories are displayed:

Date/Time/Error Code/Severity

6.6 IPMI

Use this feature to configure Intelligent Platform Management Interface (IPMI) settings.

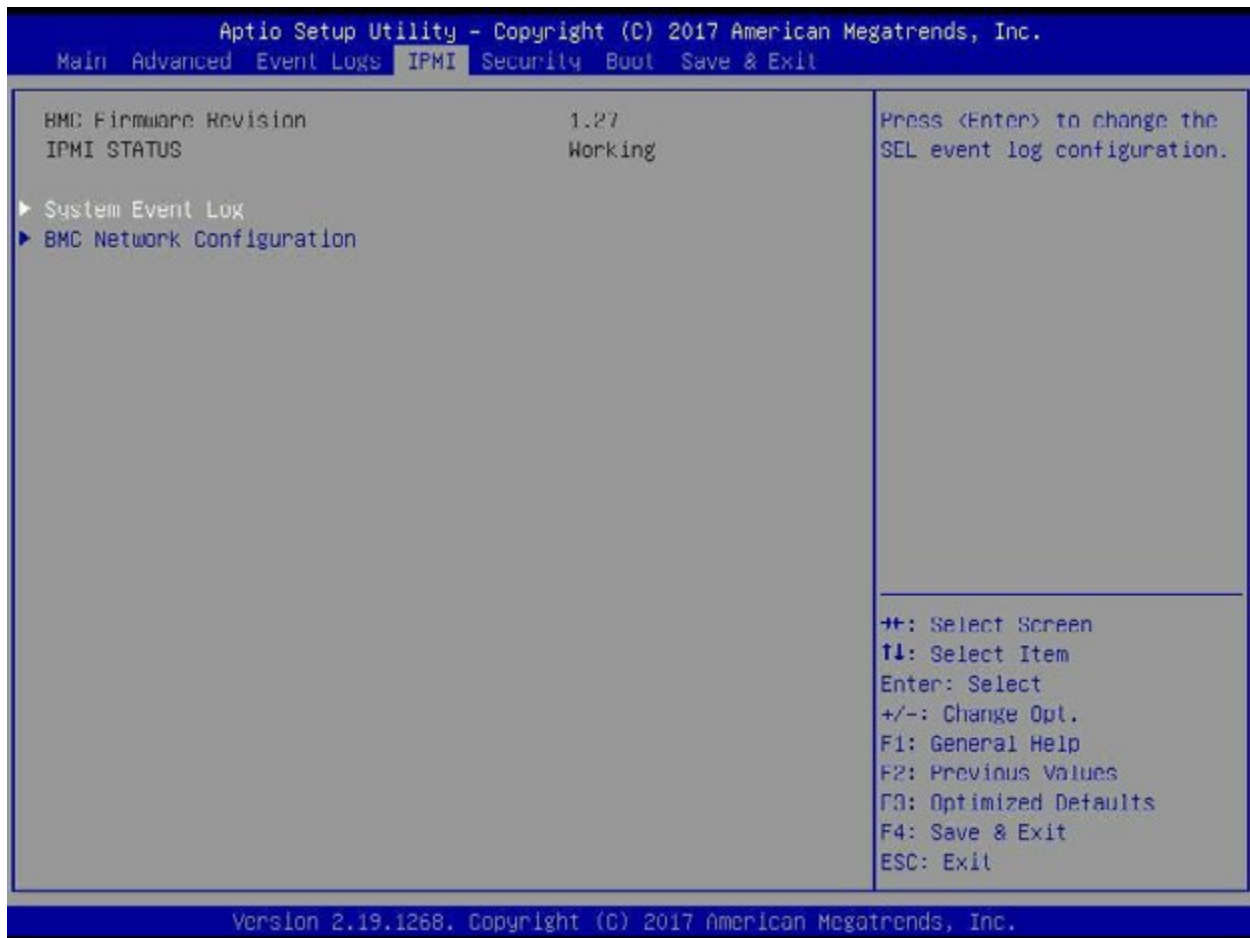

When you select this submenu and press the <Enter> key, the following information will display:

- IPMI Firmware Revision: This item indicates the IPMI firmware revision used in your system.
- Status of BMC: This item indicates the status of the BMC (Baseboard Management Controller) installed in your system.

► System Event Log

Enabling/Disabling Options

SEL Components

Select Enabled for all system event logging at bootup. The options are **Enabled** and Disabled.

Erasing Settings

Erase SEL

Select Yes, On next reset to erase all system event logs upon next system reboot. Select Yes, On every reset to erase all system event logs upon each system reboot. Select No to keep all system event logs after each system reboot. The options are **No**, Yes, On next reset, and Yes, On every reset.

When SEL is Full

This feature allows the user to determine what the BIOS should do when the system event log is full. Select Erase Immediately to erase all events in the log when the system event log is full. The options are **Do Nothing** and Erase Immediately.

Custom EFI Logging Options

Log EFI Status Codes

Select EFI (Extensible Firmware Interface) Status Codes to log EFI status codes. Select Error Codes to log EFI error codes. Select Progress Code to log the EFI progress code. Select both to log both EFI error codes and progress codes. The options are Disabled, Both, **Error code** and Progress code.

Note: After making changes on a setting, be sure to reboot the system for the changes to take effect.

► BMC Network Configuration

BMC Network Configuration

Configure IPV4 Support

This section displays configuration features for IPV4 support.

IPMI LAN Selection

This item displays the IPMI LAN setting. The default setting is **Failover**.

IPMI Network Link Status

This item displays the IPMI Network Link status. The default setting is **Shared LAN**.

Update IPMI LAN Configuration

Select Yes for the BIOS to implement all IP/MAC address changes at the next system boot. The options are **No** and Yes.

****If the item above is set to Yes, the following item will become available for configuration:***

Configuration Address Source

This feature allows the user to select the source of the IP address for this computer. If Static is selected, you will need to know the IP address of this computer and enter it to the system manually in the field. If DHCP is selected, the BIOS will search for a DHCP (Dynamic Host Configuration Protocol) server in the network that is attached to and request the next available IP address for this computer. The options are **DHCP** and Static.

****If the item above is set to Static, the following items will become available for configuration:***

Station IP Address

This item displays the Station IP address for this computer. This should be in decimal and in dotted quad form (i.e., 192.168.10.253).

Subnet Mask

This item displays the sub-network that this computer belongs to. The value of each three-digit number separated by dots should not exceed 255.

Station MAC Address

This item displays the Station MAC address for this computer. Mac addresses are 6 two-digit hexadecimal numbers.

Gateway IP Address

This item displays the Gateway IP address for this computer. This should be in decimal and in dotted quad form (i.e., 172.31.0.1).

VLAN

This item displays the virtual LAN settings. The options are Disable and Enable.

Configure IPV6 Support

This section displays configuration features for IPV6 support.

LAN Channel 1

IPV6 Support

Use this feature to enable IPV6 support. The options are **Enabled** and Disabled.

Configuration Address Source

This feature allows the user to select the source of the IP address for this computer. If Static is selected, you will need to know the IP address of this computer and enter it to the system manually in the field. If DHCP is selected, the BIOS will search for a DHCP (Dynamic Host Configuration Protocol) server in the network that is attached to and request the next available IP address for this computer. The options are **Unspecified**, Static, and DHCP.

****If the item above is set to Static, the following items will become available for configuration:***

- Station IPV6 Address
- Prefix Length
- IPV6 Router1 IP Address

6.7 Security Settings

This menu allows the user to configure the following security settings for the system.

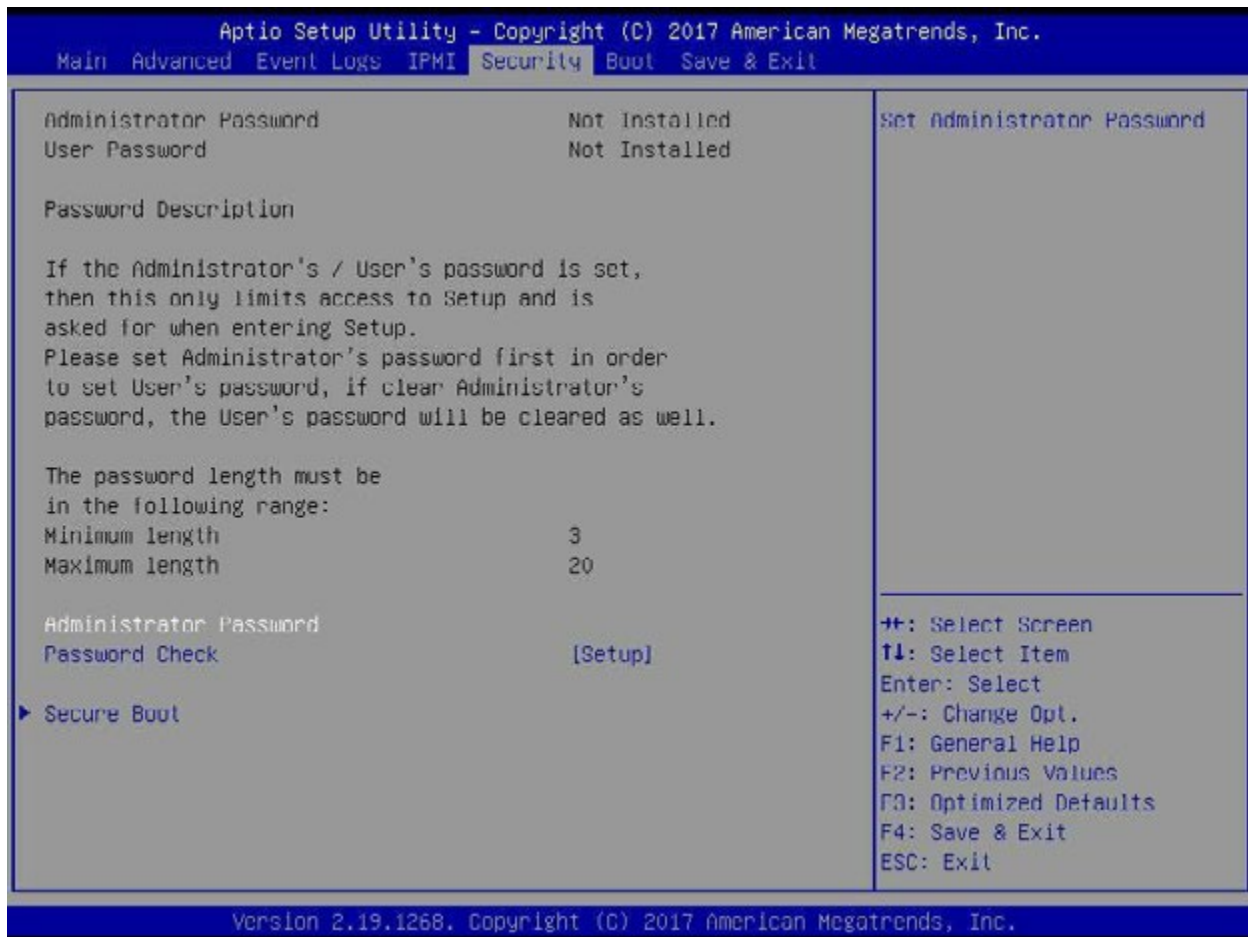

Administrator Password

Use this feature to set the administrator password which is required to enter the BIOS setup utility. The length of the password should be from 3 characters to 20 characters long.

User Password

Use this feature to set the user password which is required to enter the BIOS setup utility. The length of the password should be from 3 characters to 20 characters long.

Password Check

Select Setup for the system to check for a password at Setup. Select Always for the system to check for a password at bootup or upon entering the BIOS Setup utility. The options are **Setup** and **Always**.

▶ Secure Boot

When you select this submenu and press the <Enter> key, the following items will display:

- System Mode
- Secure Boot
- Vendor Keys

Attempt Secure Boot

If this item is set to Enabled, Secure Boot will be activated when a Platform Key (PK) is entered. A Platform Key is a security key used to manage the security settings of the platform firmware used in your system. The options are Enabled and **Disabled**.

Secure Boot Mode

Use this feature to select the desired secure boot mode for the system. The options are Standard and **Custom**.

▶ Key Management

Provision Factory Default Keys

Select Enabled to install all manufacturer default keys for the following system security settings. The options are Enabled and **Disabled**.

▶ Install Factor Default Keys

Select Yes to install all manufacturer defaults for the following system security settings. The options are **Yes** and No.

▶ Enroll EFI Image

Select this item and press <Enter> to select an EFI (Extensible Firmware Interface) image for the system to operate in Secure Boot mode.

▶ Save All Secure Boot Variables

This feature allows the user to set and save the secure boot key variables specified by the user.

Secure Boot Variables

Secure Boot Variable/Size/Key#/Key Sources

▶ Platform Key (PK)

This feature allows the user to enter and configure a set of values to be used as a platform firmware key for the system. This set of values also indicate the size, the keys numbers, and the key source of the Platform Key. The options are **Save to File**, Set New, and Erase.

▶ Key Exchange Keys

This feature allows the user to enter and configure a set of values to be used as a Key-Exchange-Keys for the system. This set of values also indicate the size, the keys numbers, and the key source of the Key-Exchange-Keys. The options are **Save to File**, Set New, and Erase.

▶ Authorized Signatures

This feature allows the user to enter and configure a set of values to be used as Authorized Signatures for the system. This set of values also indicate the size, the keys numbers, and the key source of the Authorized Signatures. The options are **Set New** and Append.

Secure Boot Variable/Size/Key#/Key Sources The options are **Save to File**, Set New, and Erase.

▶ Forbidden Signatures

This feature allows the user to enter and configure a set of values to be used as Forbidden Signatures for the system. This set of values also indicate the size, the keys numbers, and the key source of the Forbidden Signatures. The options are **Save to File**, Set New, and Erase.

▶ Authorized TimeStamps

This feature allows the user to set and save the timestamps for Authorized Signatures to indicate when these signatures were entered into the system. The options are **Save to File**, Set New, and Erase.

▶ OsRecovery Signatures

This feature allows the user to set and save the Authorized Signatures used for OS recovery. The options are **Save to File**, Set New, and Erase.

6.8 Boot Settings

Use this feature to configure Boot Settings:

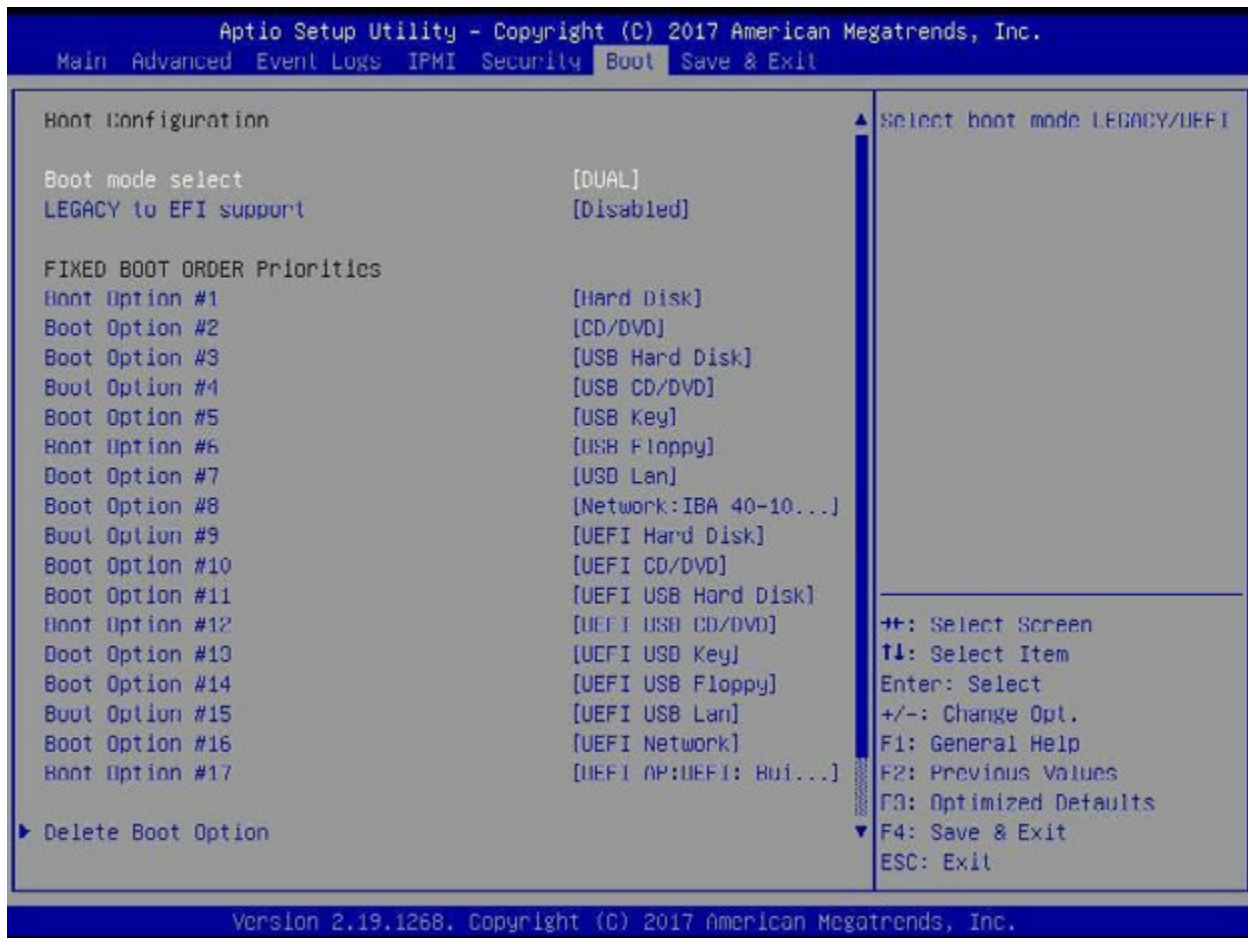

Boot Mode Select

Use this feature to select the type of devices that the system is going to boot from. The options are Legacy, UEFI (Unified Extensible Firmware Interface), and **Dual**.

Legacy to EFI Support

Select Enabled to boot EFI OS support after Legacy boot order has failed. The options are **Disabled** and Enabled.

Fixed Boot Order Priorities

This feature prioritizes the order of a bootable device from which the system will boot. Press <Enter> on each entry from top to bottom to select devices.

When the item above -"Boot Mode Select" is set to **Dual** (default), the following items will be displayed for configuration:

- Boot Option #1 - Boot Option #17

When the item above -"Boot Mode Select" is set to Legacy, the following items will be display for configuration:

- Boot Option #1 - Boot Option #8

When the item above -"Boot Mode Select" is set to UEFI, the following items will be display for configuration:

- Boot Option #1 - Boot Option #9

▶ **Delete Boot Option**

Use this feature to select a boot device to delete from the boot priority list.

Delete Boot Option

Use this feature to remove an EFI boot option from the boot priority list.

▶ **UEFI Application Boot Priorities**

This feature sets the system boot order of detected devices.

- Boot Option #1

▶ **NETWORK Drive BBS Priorities**

This feature sets the system boot order of detected devices.

- Boot Option #1

6.9 Save & Exit

Select the Save & Exit tab from the BIOS setup screen to configure the settings below.

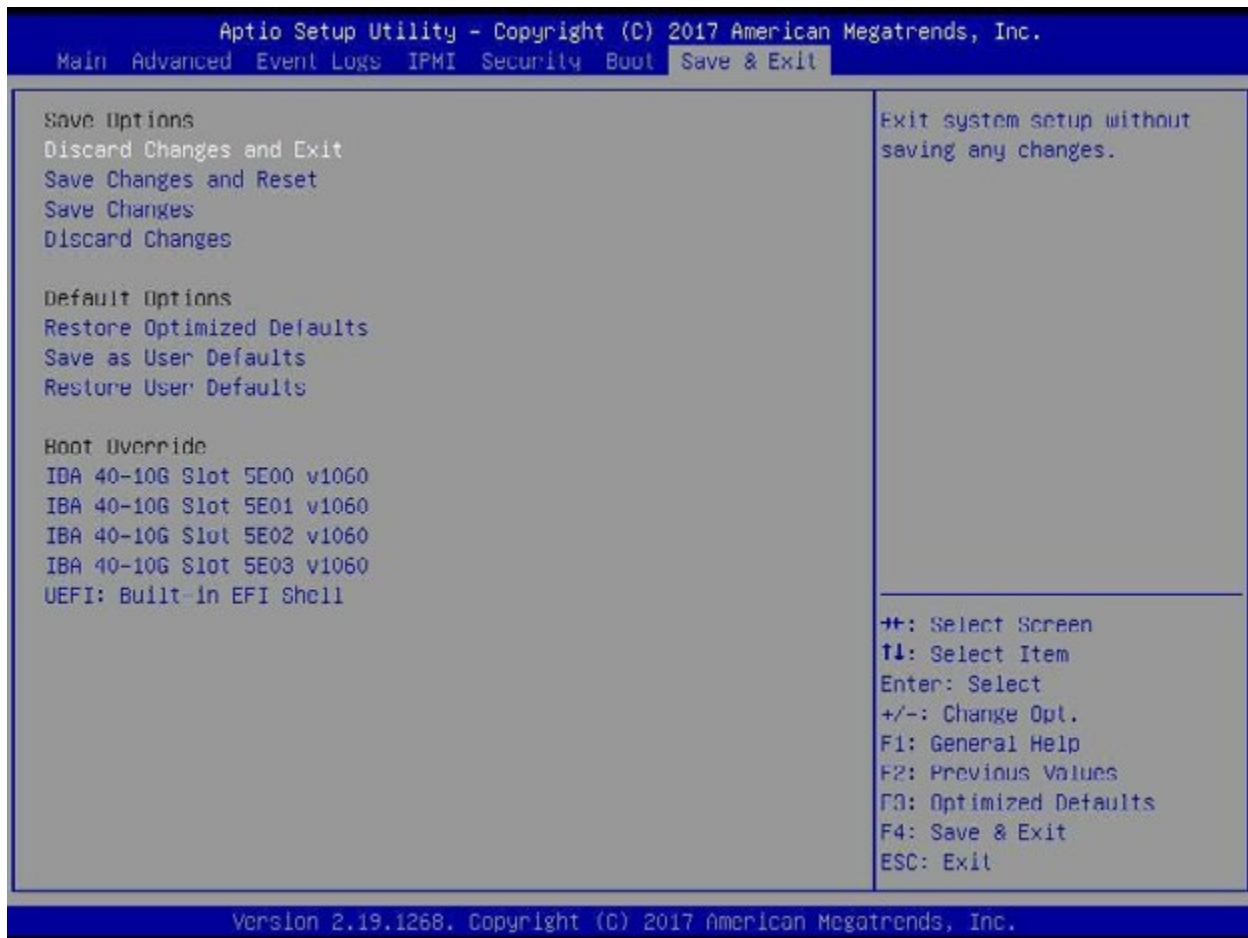

Save Options

Discard Changes and Exit

Select this option to quit the BIOS setup without making any permanent changes to the system configuration and reboot the computer. Select Discard Changes and Exit from the Exit menu and press <Enter>.

Save Changes and Reset

When you have completed the system configuration changes, select this option to leave the BIOS setup utility and reboot the computer for the new system configuration parameters to take effect. Select Save Changes and Exit from the Exit menu and press <Enter>.

Save Changes

When you have completed the system configuration changes, select this option to save all changes made. This will not reset (reboot) the system.

Discard Changes

Select this option and press <Enter> to discard all the changes and return to the AMI BIOS setup utility.

Default Options**Restore Optimized Defaults**

To set this feature, select Restore Defaults from the Exit menu and press <Enter> to load manufacturer default settings which are intended for maximum system performance but not for maximum stability.

Save As User Defaults

To set this feature, select Save as User Defaults from the Exit menu and press <Enter>. This enables the user to save any changes to the BIOS setup for future use.

Restore User Defaults

To set this feature, select Restore User Defaults from the Exit menu and press <Enter>. Use this feature to retrieve user-defined settings that were saved previously.

Boot Override

This feature allows the user to override the Boot priorities sequence in the Boot menu, and immediately boot the system with a device specified by the user instead of the one specified in the boot list. This is a one-time override.

Appendix A

BIOS Error Codes

A-1 BIOS Error Beep (POST) Codes

During the POST (Power-On Self-Test) routines, which are performed each time the system is powered on, errors may occur.

Non-fatal errors are those which, in most cases, allow the system to continue the boot-up process. The error messages normally appear on the screen.

Fatal errors are those which will not allow the system to continue the boot-up procedure. If a fatal error occurs, you should consult with your system manufacturer for possible repairs.

These fatal errors are usually communicated through a series of audible beeps. The numbers on the fatal error list (on the following page) correspond to the number of beeps for the corresponding error. All errors listed, with the exception of Beep Code 8, are fatal errors.

BIOS Error Beep (POST) Codes		
Beep Code	Error Message	Description
1 short	Refresh	Circuits have been reset (Ready to power up)
5 short, 1 long	Memory error	No memory detected in system
5 long, 2 short	Display memory read/write error	Video adapter missing or with faulty memory
1 long continuous	System OH	System overheat condition

A-2 Additional BIOS POST Codes

The AMI BIOS supplies additional checkpoint codes, which are documented online at <http://www.supermicro.com/support/manuals/> ("AMI BIOS POST Codes User's Guide").

When BIOS performs the Power On Self Test, it writes checkpoint codes to I/O port 0080h. If the computer cannot complete the boot process, a diagnostic card can be attached to the computer to read I/O port 0080h (Supermicro p/n AOC-LPC80-20).

For information on AMI updates, please refer to <http://www.ami.com/products/>.

Appendix B

Standardized Warning Statements for AC Systems

B.1 About Standardized Warning Statements

The following statements are industry standard warnings, provided to warn the user of situations which have the potential for bodily injury. Should you have questions or experience difficulty, contact Supermicro's Technical Support department for assistance. Only certified technicians should attempt to install or configure components.

Read this appendix in its entirety before installing or configuring components in the Supermicro chassis.

These warnings may also be found on our website at http://www.supermicro.com/about/policies/safety_information.cfm.

Warning Definition



Warning! This warning symbol means danger. You are in a situation that could cause bodily injury. Before you work on any equipment, be aware of the hazards involved with electrical circuitry and be familiar with standard practices for preventing accidents.

警告の定義

この警告サインは危険を意味します。

人身事故につながる可能性がありますので、いずれの機器でも動作させる前に、電気回路に含まれる危険性に注意して、標準的な事故防止策に精通して下さい。

此警告符号代表危險。

您正处于可能受到严重伤害的工作环境中。在您使用设备开始工作之前，必须充分意识到触电的危险，并熟练掌握防止事故发生的标准工作程序。请根据每项警告结尾的声明号码找到此设备的安全性警告说明的翻译文本。

此警告符號代表危險。

您正處於可能身體可能會受損傷的工作環境中。在您使用任何設備之前，請注意觸電的危險，並且要熟悉預防事故發生的標準工作程序。請依照每一注意事項後的號碼找到相關的翻譯說明內容。

Warnung

WICHTIGE SICHERHEITSHINWEISE

Dieses Warnsymbol bedeutet Gefahr. Sie befinden sich in einer Situation, die zu Verletzungen führen kann. Machen Sie sich vor der Arbeit mit Geräten mit den Gefahren elektrischer Schaltungen und den üblichen Verfahren zur Vorbeugung vor Unfällen vertraut. Suchen Sie mit der am Ende jeder Warnung angegebenen Anweisungsnummer nach der jeweiligen Übersetzung in den übersetzten Sicherheitshinweisen, die zusammen mit diesem Gerät ausgeliefert wurden.

BEWAHREN SIE DIESE HINWEISE GUT AUF.

INSTRUCCIONES IMPORTANTES DE SEGURIDAD

Este símbolo de aviso indica peligro. Existe riesgo para su integridad física. Antes de manipular cualquier equipo, considere los riesgos de la corriente eléctrica y familiarícese con los procedimientos estándar de prevención de accidentes. Al final de cada advertencia encontrará el número que le ayudará a encontrar el texto traducido en el apartado de traducciones que acompaña a este dispositivo.

GUARDE ESTAS INSTRUCCIONES.

IMPORTANTES INFORMATIONS DE SÉCURITÉ

Ce symbole d'avertissement indique un danger. Vous vous trouvez dans une situation pouvant entraîner des blessures ou des dommages corporels. Avant de travailler sur un équipement, soyez conscient des dangers liés aux circuits électriques et familiarisez-vous avec les procédures couramment utilisées pour éviter les accidents. Pour prendre connaissance des traductions des avertissements figurant dans les consignes de sécurité traduites qui accompagnent cet appareil, référez-vous au numéro de l'instruction situé à la fin de chaque avertissement.

CONSERVEZ CES INFORMATIONS.

תקנון הזהרות אזהרה

הזהרות הבאות הן אזהרות על פי תקני התעשייה, על מנת להזהיר את המשתמש מפני חבלה פיזית אפשרית. במידה ויש שאלות או היתקלות בבעיה כלשהי, יש ליצור קשר עם מחלקת תמיכה טכנית של סופרמיקרו. טכנאים מוסמכים בלבד רשאים להתקין או להגדיר את הרכיבים. יש לקרוא את הנספח במלואו לפני התקנת או הגדרת הרכיבים במארזי סופרמיקרו.

اَكْ ف حالة وُكِي اَي تتسبب ف اصابة جسدهُ هذا الزهز عُ خطر! تحذُرُ .
قبل اَي تعول على اَي هعدات، كي على علن بالوخاطز ال اُجوة عي الذوائر
الكهزبائِة
وكي على دراةُ بالووارسات النقاائِة لو عُ وقع اَي حادث
استخدم رِقن الب اِي الو صُص ف هَّاةُ كل تحذُرُ للعشر تزجوتها

안전을 위한 주의사항

경고!

이 경고 기호는 위험이 있음을 알려 줍니다. 작업자의 신체에 부상을 야기 할 수 있는 상태에 있게 됩니다. 모든 장비에 대한 작업을 수행하기 전에 전기회로와 관련된 위험요소들을 확인하시고 사전에 사고를 방지할 수 있도록 표준 작업절차를 준수해 주시기 바랍니다.

해당 번역문을 찾기 위해 각 경고의 마지막 부분에 제공된 경고문 번호를 참조하십시오

BELANGRIJKE VEILIGHEIDSINSTRUCTIES

Dit waarschuwings symbool betekent gevaar. U verkeert in een situatie die lichamelijk letsel kan veroorzaken. Voordat u aan enige apparatuur gaat werken, dient u zich bewust te zijn van de bij een elektrische installatie betrokken risico's en dient u op de hoogte te zijn van de standaard procedures om ongelukken te voorkomen. Gebruik de nummers aan het eind van elke waarschuwing om deze te herleiden naar de desbetreffende locatie.

BEWAAR DEZE INSTRUCTIES

Installation Instructions



Warning! Read the installation instructions before connecting the system to the power source.

設置手順書

システムを電源に接続する前に、設置手順書をお読み下さい。

警告

将此系统连接电源前,请先阅读安装说明。

警告

將系統與電源連接前，請先閱讀安裝說明。

Warnung

Vor dem Anschließen des Systems an die Stromquelle die Installationsanweisungen lesen.

¡Advertencia!

Lea las instrucciones de instalación antes de conectar el sistema a la red de alimentación.

Attention

Avant de brancher le système sur la source d'alimentation, consulter les directives d'installation.

יש לקרוא את הוראות התקנה לפני חיבור המערכת למקור מתח.

اقر إرشادات التركيب قبل توصيل النظام إلى مصدر للطاقة

시스템을 전원에 연결하기 전에 설치 안내를 읽어주십시오.

Waarschuwing

Raadpleeg de installatie-instructies voordat u het systeem op de voedingsbron aansluit.

Circuit Breaker



Warning! This product relies on the building's installation for short-circuit (overcurrent) protection. Ensure that the protective device is rated not greater than: 250 V, 20 A.

サーキット・ブレーカー

この製品は、短絡(過電流)保護装置がある建物での設置を前提としています。

保護装置の定格が250 V、20 Aを超えないことを確認下さい。

警告

此产品的短路(过载电流)保护由建筑物的供电系统提供,确保短路保护设备的额定电流不大于250V,20A。

警告

此產品的短路(過載電流)保護由建築物的供電系統提供,確保短路保護設備的額定電流不大於250V,20A。

Warnung

Dieses Produkt ist darauf angewiesen, dass im Gebäude ein Kurzschluss- bzw. Überstromschutz installiert ist. Stellen Sie sicher, dass der Nennwert der Schutzvorrichtung nicht mehr als: 250 V, 20 A beträgt.

¡Advertencia!

Este equipo utiliza el sistema de protección contra cortocircuitos (o sobrecorrientes) del edificio. Asegúrese de que el dispositivo de protección no sea superior a: 250 V, 20 A.

Attention

Pour ce qui est de la protection contre les courts-circuits (surtension), ce produit dépend de l'installation électrique du local. Vérifiez que le courant nominal du dispositif de protection n'est pas supérieur à :250 V, 20 A.

מוצר זה מסתמך על הגנה המותקנת במבנים למניעת קצר חשמלי. יש לוודא כי המכשיר המגן מפני הקצר החשמלי הוא לא יותר מ-250VDC, 20A

هذا المنتج يعتمد على معدات الحماية مه الدوائر القصيرة التي تم تثبيتها في المبنى
تأكد من أن تقييم الجهاز الوقائي ليس أكثر من : 20A, 250V

경고!

이 제품은 전원의 단락(과전류)방지에 대해서 전적으로 건물의 관련 설비에 의존합니다. 보호장치의 정격이 반드시 250V(볼트), 20A(암페어)를 초과하지 않도록 해야 합니다.

Waarschuwing

Dit product is afhankelijk van de kortsluitbeveiliging (overspanning) van uw elektrische installatie. Controleer of het beveiligde apparaat niet groter gedimensioneerd is dan 250V, 20A.

Power Disconnection Warning



Warning! The system must be disconnected from all sources of power and the power cord removed from the power supply module(s) before accessing the chassis interior to install or remove system components.

電源切斷の警告

システムコンポーネントの取り付けまたは取り外しのために、シャーシ内部にアクセスするには、システムの電源はすべてのソースから切斷され、電源コードは電源モジュールから取り外す必要があります。

警告

在你打开机箱并安装或移除内部器件前,必须将系统完全断电,并移除电源线。

警告

在您打開機殼安裝或移除內部元件前，必須將系統完全斷電，並移除電源線。

Warnung

Das System muss von allen Quellen der Energie und vom Netzanschlusskabel getrennt sein, das von den Spg.Versorgungsteilmodulen entfernt wird, bevor es auf den Chassisinnenraum zurückgreift, um Systemsbestandteile anzubringen oder zu entfernen.

¡Advertencia!

El sistema debe ser disconnected de todas las fuentes de energía y del cable eléctrico quitado de los módulos de fuente de alimentación antes de tener acceso el interior del chasis para instalar o para quitar componentes de sistema.

Attention

Le système doit être débranché de toutes les sources de puissance ainsi que de son cordon d'alimentation secteur avant d'accéder à l'intérieur du chasis pour installer ou enlever des composants de système.

אזהרה מפני ניתוק חשמלי

אזהרה!

יש לנתק את המערכת מכל מקורות החשמל ויש להסיר את כבל החשמלי מהספק לפני גישה לחלק הפנימי של המארז לצורך התקנת או הסרת רכיבים.

يجب فصل انظاؤ من جميع مصادر انطاقت وإزانت سهك انكهرباء من وحدة امداد
انطاقت قيم
انصل إني امنطاق انداخهيت نههيكم نتشيج أو إزانت مكناث الجهاز

경고!

시스템에 부품들을 장착하거나 제거하기 위해서는 새시 내부에 접근하기 전에 반드시 전원 공급장치로부터 연결되어있는 모든 전원과 전기코드를 분리해주어야 합니다.

Waarschuwing

Voordat u toegang neemt tot het binnenwerk van de behuizing voor het installeren of verwijderen van systeem onderdelen, dient u alle spanningsbronnen en alle stroomkabels aangesloten op de voeding(en) van de behuizing te verwijderen

Equipment Installation



Warning! Only trained and qualified personnel should be allowed to install, replace, or service this equipment.

機器の設置

トレーニングを受け認定された人だけがこの装置の設置、交換、またはサービスを許可されてい
ます。

警告

只有经过培训且具有资格的人员才能进行此设备的安装、更换和维修。

警告

只有經過受訓且具資格人員才可安裝、更換與維修此設備。

Warnung

Das Installieren, Ersetzen oder Bedienen dieser Ausrüstung sollte nur geschultem, qualifiziertem Personal gestattet werden.

¡Advertencia!

Solamente el personal calificado debe instalar, reemplazar o utilizar este equipo.

Attention

Il est vivement recommandé de confier l'installation, le remplacement et la maintenance de ces équipements à des personnels qualifiés et expérimentés.

אזהרה!

צוות מוסמך בלבד רשאי להתקין, להחליף את הציוד או לתת שירות עבור הציוד.

والمدربيه لتزكيب واستبدال أو خدمة هذا الجهاز يجب أن يسمح فقط للمظفيه المؤهليه

경고!

훈련을 받고 공인된 기술자만이 이 장비의 설치, 교체 또는 서비스를 수행할 수 있습니다.

Waarschuwing

Deze apparatuur mag alleen worden geïnstalleerd, vervangen of hersteld door geschoold en gekwalificeerd personeel.

Restricted Area

Warning! This unit is intended for installation in restricted access areas. A restricted access area can be accessed only through the use of a special tool, lock and key, or other means of security. (This warning does not apply to workstations).

アクセス制限区域

このユニットは、アクセス制限区域に設置されることを想定しています。

アクセス制限区域は、特別なツール、鍵と錠前、その他のセキュリティの手段を用いてのみ出入りが可能です。

警告

此部件应安装在限制进出的场所，限制进出的场所指只能通过使用特殊工具、锁和钥匙或其它安全手段进出的场所。

警告

此装置仅限安装於進出管制區域，進出管制區域係指僅能以特殊工具、鎖頭及鑰匙或其他安全方式才能進入的區域。

Warnung

Diese Einheit ist zur Installation in Bereichen mit beschränktem Zutritt vorgesehen. Der Zutritt zu derartigen Bereichen ist nur mit einem Spezialwerkzeug, Schloss und Schlüssel oder einer sonstigen Sicherheitsvorkehrung möglich.

¡Advertencia!

Esta unidad ha sido diseñada para instalación en áreas de acceso restringido. Sólo puede obtenerse acceso a una de estas áreas mediante la utilización de una herramienta especial, cerradura con llave u otro medio de seguridad.

Attention

Cet appareil doit être installée dans des zones d'accès réservés. L'accès à une zone d'accès réservé n'est possible qu'en utilisant un outil spécial, un mécanisme de verrouillage et une clé, ou tout autre moyen de sécurité.

אזור עם גישה מוגבלת

אזהרה!

יש להתקין את היחידה באזורים שיש בהם הגבלת גישה. הגישה ניתנת בעזרת 'כלי אבטחה בלבד' (מפתח, מנעול וכד.).

تخصيص هذه انحدة نترك بها ف مناطق محظورة تم .
ممكن اننصل إن منطقت محظورة فقط من خلال استخذاو أداة خاصت
أو أ وس هت أكري نلالأمما ققم ومفتاح

경고!

이 장치는 접근이 제한된 구역에 설치하도록 되어있습니다. 특수도구, 잠금 장치 및 키, 또는 기타 보안 수단을 통해서만 접근 제한 구역에 들어갈 수 있습니다.

Waarschuwing

Dit apparaat is bedoeld voor installatie in gebieden met een beperkte toegang. Toegang tot dergelijke gebieden kunnen alleen verkregen worden door gebruik te maken van speciaal gereedschap, slot en sleutel of andere veiligheidsmaatregelen.

Battery Handling



Warning! There is the danger of explosion if the battery is replaced incorrectly. Replace the battery only with the same or equivalent type recommended by the manufacturer. Dispose of used batteries according to the manufacturer's instructions

電池の取り扱い

電池交換が正しく行われなかった場合、破裂の危険性があります。交換する電池はメーカーが推奨する型、または同等のものを使用下さい。使用済電池は製造元の指示に従って処分して下さい。

警告

電池更換不當會有爆炸危險。請只使用同類電池或制造商推荐的功能相当的電池更換原有電池。請按制造商的說明處理廢舊電池。

警告

電池更換不當會有爆炸危險。請使用製造商建議之相同或功能相當的電池更換原有電池。請按照製造商的說明指示處理廢棄舊電池。

Warnung

Bei Einsetzen einer falschen Batterie besteht Explosionsgefahr. Ersetzen Sie die Batterie nur durch den gleichen oder vom Hersteller empfohlenen Batterietyp. Entsorgen Sie die benutzten Batterien nach den Anweisungen des Herstellers.

Attention

Danger d'explosion si la pile n'est pas remplacée correctement. Ne la remplacer que par une pile de type semblable ou équivalent, recommandée par le fabricant. Jeter les piles usagées conformément aux instructions du fabricant.

¡Advertencia!

Existe peligro de explosión si la batería se reemplaza de manera incorrecta. Reemplazar la batería exclusivamente con el mismo tipo o el equivalente recomendado por el fabricante. Desechar las baterías gastadas según las instrucciones del fabricante.

אזהרה!

קיימת סכנת פיצוץ של הסוללה במידה והוחלפה בדרך לא תקינה. יש להחליף את הסוללה בסוג התואם מחברת יצרן מומלצת. סילוק הסוללות המשומשות יש לבצע לפי הוראות היצרן.

هناك خطر من انفجار في حالة اسبدال البطارية بطريقة غير صحيحة فعلى
اسبدال البطارية
فقط بنفس النوع أو ما يعادلها مما أوصت به الشركة المصنعة
جخلص من البطاريات المسحومة وفقا لعمليات الشركة الصانعة

경고!

배터리가 올바르게 교체되지 않으면 폭발의 위험이 있습니다. 기존 배터리와 동일하거나 제조사에서 권장하는 동등한 종류의 배터리로만 교체해야 합니다. 제조사의 안내에 따라 사용된 배터리를 처리하여 주십시오.

Waarschuwing

Er is ontploffingsgevaar indien de batterij verkeerd vervangen wordt. Vervang de batterij slechts met hetzelfde of een equivalent type die door de fabrikant aanbevolen wordt. Gebruikte batterijen dienen overeenkomstig fabrieksvoorschriften afgevoerd te worden.

Redundant Power Supplies



Warning! This unit might have more than one power supply connection. All connections must be removed to de-energize the unit.

冗長電源装置

このユニットは複数の電源装置が接続されている場合があります。

ユニットの電源を切るためには、すべての接続を取り外さなければなりません。

警告

此部件连接的电源可能不止一个，必须将所有电源断开才能停止给该部件供电。

警告

此装置连接的电源可能不只一个，必须切断所有电源才能停止对该装置的供电。

Warnung

Dieses Gerät kann mehr als eine Stromzufuhr haben. Um sicherzustellen, dass der Einheit kein Strom zugeführt wird, müssen alle Verbindungen entfernt werden.

¡Advertencia!

Puede que esta unidad tenga más de una conexión para fuentes de alimentación. Para cortar por completo el suministro de energía, deben desconectarse todas las conexiones.

Attention

Cette unité peut avoir plus d'une connexion d'alimentation. Pour supprimer toute tension et tout courant électrique de l'unité, toutes les connexions d'alimentation doivent être débranchées.

אם קיים יותר מספק אחד

אזהרה!

ליחידה יש יותר מחיבור אחד של ספק. יש להסיר את כל החיבורים על מנת לרוקן את היחידה.

قد يكون لهذا الجهاز عدة اتصالات بوحدات امداد الطاقة .

يجب إزالة كافة الاتصالات لعسل الوحدة عن الكهرباء

경고!

이 장치에는 한 개 이상의 전원 공급 단자가 연결되어 있을 수 있습니다. 이 장치에 전원을 차단하기 위해서는 모든 연결 단자를 제거해야만 합니다.

Waarschuwing

Deze eenheid kan meer dan één stroomtoevoeraansluiting bevatten. Alle aansluitingen dienen verwijderd te worden om het apparaat stroomloos te maken.

Backplane Voltage



Warning! Hazardous voltage or energy is present on the backplane when the system is operating. Use caution when servicing.

バックプレーンの電圧

システムの稼働中は危険な電圧または電力が、バックプレーン上にかかっています。

修理する際には注意ください。

警告

当システム正在进行时，背板上有很危险的电压或能量，进行维修时务必小心。

警告

當系統正在進行時，背板上危險的電壓或能量，進行維修時務必小心。

Warnung

Wenn das System in Betrieb ist, treten auf der Rückwandplatine gefährliche Spannungen oder Energien auf. Vorsicht bei der Wartung.

¡Advertencia!

Cuando el sistema está en funcionamiento, el voltaje del plano trasero es peligroso. Tenga cuidado cuando lo revise.

Attention

Lorsque le système est en fonctionnement, des tensions électriques circulent sur le fond de panier. Prendre des précautions lors de la maintenance.

מתח בפנל האחורי

אזהרה!

קיימת סכנת מתח בפנל האחורי בזמן תפעול המערכת. יש להיזהר במהלך העבודה.

هناك خطر من التيار الكهربائي أو الطاقة المتجددة على اللوحة
عندما يكون النظام يعمل كه حذرا عند خدمة هذا الجهاز

경고!

시스템이 동작 중일 때 후면판 (Backplane)에는 위험한 전압이나 에너지가 발생 합니다.
서비스 작업 시 주의하십시오.

Waarschuwing

Een gevaarlijke spanning of energie is aanwezig op de backplane wanneer het systeem in gebruik is. Voorzichtigheid is geboden tijdens het onderhoud.

Comply with Local and National Electrical Codes



Warning! Installation of the equipment must comply with local and national electrical codes.

地方および国の電気規格に準拠

機器の取り付けはその地方および国の電気規格に準拠する必要があります。

警告

设备安装必须符合本地与本国电气法规。

警告

設備安裝必須符合本地與本國電氣法規。

Warnung

Die Installation der Geräte muss den Sicherheitsstandards entsprechen.

¡Advertencia!

La instalación del equipo debe cumplir con las normas de electricidad locales y nacionales.

Attention

L'équipement doit être installé conformément aux normes électriques nationales et locales.

תיאום חוקי החשמל הארצי

אזהרה!

התקנת הציוד חייבת להיות תואמת לחוקי החשמל המקומיים והארציים.

تركيب المعدات الكهربائية يجب أن يمتثل للقوايه المحلية والبطية المتعلقة
بالكهرباء

경고!

현 지역 및 국가의 전기 규정에 따라 장비를 설치해야 합니다.

Waarschuwing

Bij installatie van de apparatuur moet worden voldaan aan de lokale en nationale elektriciteitsvoorschriften.

Product Disposal



Warning! Ultimate disposal of this product should be handled according to all national laws and regulations.

製品の廃棄

この製品を廃棄処分する場合、国の関係する全ての法律・条例に従い処理する必要があります。

警告

本产品的废弃处理应根据所有国家的法律和规章进行。

警告

本產品的廢棄處理應根據所有國家的法律和規章進行。

Warnung

Die Entsorgung dieses Produkts sollte gemäß allen Bestimmungen und Gesetzen des Landes erfolgen.

¡Advertencia!

Al deshacerse por completo de este producto debe seguir todas las leyes y reglamentos nacionales.

Attention

La mise au rebut ou le recyclage de ce produit sont généralement soumis à des lois et/ou directives de respect de l'environnement. Renseignez-vous auprès de l'organisme compétent.

סילוק המוצר

אזהרה!

סילוק סופי של מוצר זה חייב להיות בהתאם להנחיות וחוקי המדינה.

التخلص النهائي من هذا المنتج ينبغي التعامل معه وفقا لجميع القوانين واللوائح الوطنية عند

경고!

이 제품은 해당 국가의 관련 법규 및 규정에 따라 폐기되어야 합니다.

Waarschuwing

De uiteindelijke verwijdering van dit product dient te geschieden in overeenstemming met alle nationale wetten en reglementen.

Hot Swap Fan Warning



Warning! Hazardous moving parts. Keep away from moving fan blades. The fans might still be turning when you remove the fan assembly from the chassis. Keep fingers, screwdrivers, and other objects away from the openings in the fan assembly's housing.

ファン・ホットスワップの警告

警告!回転部品に注意。運転中は回転部(羽根)に触れないでください。シャーシから冷却ファン装置を取り外した際、ファンがまだ回転している可能性があります。ファンの開口部に、指、ドライバー、およびその他のものを近づけないで下さい。

警告!

警告! 危險的可移動性零件。請務必與轉動的風扇葉片保持距離。當您從機架移除風扇裝置，風扇可能仍在轉動。小心不要將手指、螺絲起子和其他物品太靠近風扇

警告

危險的可移動性零件。請務必與轉動的風扇葉片保持距離。當您從機架移除風扇裝置，風扇可能仍在轉動。小心不要將手指、螺絲起子和其他物品太靠近風扇。

Warnung

Gefährlich Bewegende Teile. Von den bewegenden Lüfterblätter fern halten. Die Lüfter drehen sich u. U. noch, wenn die Lüfterbaugruppe aus dem Chassis genommen wird. Halten Sie Finger, Schraubendreher und andere Gegenstände von den Öffnungen des Lüftergehäuses entfernt.

¡Advertencia!

Riesgo de piezas móviles. Mantener alejado de las aspas del ventilador. Los ventiladores podran dar vuelta cuando usted quite el montaje del ventilador del chasis. Mantenga los dedos, los destornilladores y todos los objetos lejos de las aberturas del ventilador

Attention

Pieces mobiles dangereuses. Se tenir a l'écart des lames du ventilateur Il est possible que les ventilateurs soient toujours en rotation lorsque vous retirerez le bloc ventilateur du châssis. Prenez garde à ce que doigts, tournevis et autres objets soient éloignés du logement du bloc ventilateur.

אזהרה!

חלקים נעים מסוכנים. התרחק מלהבי המאוורר בפעולה כאשר מסירים את חלקי המאוורר מהמארז, יתכן והמאווררים עדיין עובדים. יש להרחיק למרחק בטוח את האצבעות וכלי עבודה שונים מהפתחים בתוך המאוורר

تحذير! أجزاء متحركة خطيرة. ابتعد عن شفرات المروحة المتحركة. من الممكن أن المراوح لا تزال تدور عند إزالة كتلة المروحة من الهيكل يجب إبقاء الأصابع ومفكات البراغي وغيرها من الأشياء بعيدا عن الفتحات في كتلة المروحة

경고!

움직이는 위험한 부품. 회전하는 송풍 날개에 접근하지 마세요. 새시로부터 팬 조립품을 제거할 때 팬은 여전히 회전하고 있을 수 있습니다. 팬 조립품 외관의 열려있는 부분들로부터 손가락 및 스크류드라이버, 다른 물체들이 가까이 하지 않도록 배치해 주십시오.

Waarschuwing

Gevaarlijk bewegende onderdelen. Houd voldoende afstand tot de bewegende ventilatorbladen. Het is mogelijk dat de ventilator nog draait tijdens het verwijderen van het ventilatorsamenstel uit het chassis. Houd uw vingers, schroevendraaiers en eventuele andere voorwerpen uit de buurt van de openingen in de ventilatorbehuizing.

Power Cable and AC Adapter



Warning! When installing the product, use the provided or designated connection cables, power cables and AC adaptors. Using any other cables and adaptors could cause a malfunction or a fire. Electrical Appliance and Material Safety Law prohibits the use of UL or CSA-certified cables (that have UL/CSA shown on the cord) for any other electrical devices than products designated by Supermicro only.

電源コードとACアダプター

製品を設置する場合、提供または指定および購入された接続ケーブル、電源コードとACアダプターを、該当する地域の条例や安全基準に適合するコードサイズやプラグと共に使用下さい。他のケーブルやアダプタを使用すると故障や火災の原因になることがあります。

電気用品安全法は、ULまたはCSA認定のケーブル(UL/CSEマークがコードに表記)を Supermicro が指定する製品以外に使用することを禁止しています。

警告

安装此产品时,请使用本身提供的或指定的或采购的连接线,电源线和电源适配器。包含遵照当地法规和安全要求的合规的电源线尺寸和插头。使用其它线材或适配器可能会引起故障或火灾。除了Supermicro所指定的产品,电气用品和材料安全法律规定禁止使用未经UL或CSA认证的线材。(线材上会显示UL/CSA符号)。

警告

安裝此產品時,請使用本身提供的或指定的或採購的連接線,電源線和電源適配器。包含遵照當地法規和安全要求的合規的電源線尺寸和插頭。使用其它線材或適配器可能會引起故障或火災。除了Supermicro所指定的產品,電氣用品和材料安全法律規定禁止使用未經UL或CSA認證的線材。(線材上會顯示UL/CSA符號)。

Warnung

Nutzen Sie beim Installieren des Produkts ausschließlich die von uns zur Verfügung gestellten Verbindungskabeln, Stromkabeln und/oder Adapter, die Ihre örtlichen Sicherheitsstandards einhalten. Der Gebrauch von anderen Kabeln und Adapter können Fehlfunktionen oder Feuer verursachen. Die Richtlinien untersagen das Nutzen von UL oder CAS zertifizierten Kabeln (mit UL/CSA gekennzeichnet), an Geräten oder Produkten die nicht mit Supermicro gekennzeichnet sind.

¡Advertencia!

Cuando instale el producto, utilice la conexión provista o designada o procure cables, Cables de alimentación y adaptadores de CA que cumplan con los códigos locales y los requisitos de seguridad, incluyendo el tamaño adecuado del cable y el enchufe. El uso de otros cables y adaptadores podría causar un mal funcionamiento o un incendio. La Ley de Seguridad de Aparatos Eléctricos y de Materiales prohíbe El uso de cables certificados por UL o CSA (que tienen el certificado UL / CSA en el código) para cualquier otros dispositivos eléctricos que los productos designados únicamente por Supermicro.

Attention

Lors de l'installation du produit, utilisez les cables de connection fournis ou désigné ou achetez des cables, cables de puissance et adaptateurs respectant les normes locales et les conditions de securite y compris les tailles de cables et les prises electriques appropries. L'utilisation d'autres cables et adaptateurs peut provoquer un dysfonctionnement ou un incendie. Appareils électroménagers et la Loi sur la Sécurité Matériel interdit l'utilisation de câbles certifiés- UL ou CSA (qui ont UL ou CSA indiqué sur le code) pour tous les autres appareils électriques sauf les produits désignés par Supermicro seulement.

AC כבלים חשמליים ומתאמי

אזהרה!

אשר נרכשו או הותאמו לצורך ההתקנה, ואשר הותאמו לדרישות AC כאשר מתקינים את המוצר, יש להשתמש בכבלים, ספקים ומתאמים הבטיחות המקומיות, כולל מידה נכונה של הכבל והתקע. שימוש בכל כבל או מתאם מסוג אחר, עלול לגרום לתקלה או קצר חשמלי. בהתאם כאשר מופיע עליהם קוד) UL-CSA או ב UL - לחוקי השימוש במכשירי החשמל וחוקי הבטיחות, קיים איסור להשתמש בכבלים המוסמכים ב Supermicro עבור כל מוצר חשמלי אחר, אלא רק במוצר אשר הותאם ע"י UL/CSA של

עند تركيب المنتج، قم باستخدام التوصيلات المتوفرة أو المحددة أو قم بشراء الكابلات الكهربائية ومحوطات التيار المتردد مع الالتزام بقوانين ومتطلبات السلامة المحلية بما في ذلك حجم الموصل والقابس السليم. استخدام أي كابلات ومحوطات أخرى قد يتسبب في عطل أو حريق. يحظر قانون السلامة للأجهزة الكهربائية والمعدات استخدام الكابلات المعتمدة Supermicro مع أي معدات أخرى غير المنتجات المعينة والمحددة من قبل (UL/CSA) والتي تحمل علامة CSA أو UL من قبل

전원 케이블 및 AC 어댑터

경고! 제품을 설치할 때 현지 코드 및 적절한 굵기의 코드와 플러그를 포함한 안전 요구 사항을 준수하여 제공되거나 지정된 연결 혹은 구매 케이블, 전원 케이블 및 AC 어댑터를 사용하십시오.

다른 케이블이나 어댑터를 사용하면 오작동이나 화재가 발생할 수 있습니다. 전기 용품 안전법은 UL 또는 CSA 인증 케이블 (코드에 UL / CSA가 표시된 케이블)을 Supermicro가 지정한 제품 이외의 전기 장치에 사용하는 것을 금지합니다.

Stroomkabel en AC-Adapter

Waarschuwing! Bij het aansluiten van het Product uitsluitend gebruik maken van de geleverde Kabels of een andere geschikte aan te schaffen Aansluitmethode, deze moet altijd voldoen aan de lokale voorschriften en veiligheidsnormen, inclusief de juiste kabeldikte en stekker. Het gebruik van niet geschikte Kabels en/of Adapters kan een storing of brand veroorzaken. Wetgeving voor Elektrische apparatuur en Materiaalveiligheid verbied het gebruik van UL of CSA -gecertificeerde Kabels (met UL/CSA in de code) voor elke andere toepassing dan de door Supermicro hiervoor beoogde Producten.

Appendix C

System Specifications

Processors

Dual Intel Xeon 81xx/61xx/51xx/41xx/31xx series in an Socket P type sockets for each node.

Note: Please refer to the motherboard specifications pages on our website for updates to supported processors.

Chipset

Intel Intel C621 chipset

BIOS

128 Mb AMI® Flash ROM

Memory

Twelve (12) 240-pin DIMM slots that can support up to 1536 GB of 72-bit DDR4 unbuffered ECC 2666/2400/2133 Mhz speed SDRAM

Note: See the memory section in Chapter 3 for details and our website for updates to supported memory.

SATA Controller

On-chip (Intel C621) controller

Drive Bays

Thirty-two (32) 3.5" hot-swap drive bays in four nodes

PCI Expansion Slots

One (1) PCI-Express 3.0 (x16) slot

One (1) PCI-Express 3.0 x16 (x8 + x8) SMCI storage Slot (JSXB2)

One (1) PCI-Express 3.0 x16 SIOM LAN Port

Motherboard

X11DPFR-S/SN Proprietary form factor ((LxW): 9.66" x 8.53" (216.66 mm x 499.36 mm))

Chassis

F424AS2-R1K23BP; 4U Rackmount, 17.2 x 1.7 x 20 in. / 437 x 43 x 508 mm. (W x H x D)

System Cooling

Eight 8-cm PWM fans

Power Supply

Model: PWS-1K23A-1R

AC Input Voltages: 100-240 VAC

Rated Input Current: 15-12A (100-127V) to 8.5-7A (200-240V)

Rated Input Frequency: 50-60 Hz

Rated Output Power: 1000W/1200W

Rated Output Voltages: 83A (+12V 100-127Vac), 100A (+12V 200-240Vac), 0-4A (+5Vsb)

Operating Environment

Operating Temperature: 10° to 35° C (50° to 95° F)

Non-operating Temperature: -40° to 60° C (-40° to 140° F)

Operating Relative Humidity: 8% to 90% (non-condensing)

Non-operating Relative Humidity: 5% to 95% (non-condensing)

Regulatory Compliance

Electromagnetic Emissions: FCC Class A, EN 55022 Class A, EN 61000-3-2/3-3, CISPR 22 Class A

Electromagnetic Immunity: EN 55024/CISPR 24, (EN 61000-4-2, EN 61000-4-3, EN 61000-4-4, EN 61000-4-5, EN 61000-4-6, EN 61000-4-8, EN 61000-4-11)

Safety: CSA/EN/IEC/UL 60950-1 Compliant, UL or CSA Listed (USA and Canada), CE Marking (Europe)

Perchlorate Warning

California Best Management Practices Regulations for Perchlorate Materials: This Perchlorate warning applies only to products containing CR (Manganese Dioxide) Lithium coin cells. "Perchlorate Material-special handling may apply. See www.dtsc.ca.gov/hazardouswaste/perchlorate"

Appendix D

UEFI BIOS Recovery

Warning: Do not upgrade the BIOS unless your system has a BIOS-related issue. Flashing the wrong BIOS can cause irreparable damage to the system. In no event shall Supermicro be liable for direct, indirect, special, incidental, or consequential damages arising from a BIOS update. If you need to update the BIOS, do not shut down or reset the system while the BIOS is updating to avoid possible boot failure.

D.1 Overview

The Unified Extensible Firmware Interface (UEFI) provides a software-based interface between the operating system and the platform firmware in the pre-boot environment. The UEFI specification supports an architecture-independent mechanism that will allow the UEFI OS loader stored in an add-on card to boot the system. The UEFI offers clean, hands-off management to a computer during system boot.

D.2 Recovering the UEFI BIOS Image

A UEFI BIOS flash chip consists of a recovery BIOS block and a main BIOS block (a main BIOS image). The recovery block contains critical BIOS codes, including memory detection and recovery codes for the user to flash a healthy BIOS image if the original main BIOS image is corrupted. When the system power is turned on, the recovery block codes execute first. Once this process is complete, the main BIOS code will continue with system initialization and the remaining POST (Power-On Self-Test) routines.

Note 1: Follow the BIOS recovery instructions below for BIOS recovery when the main BIOS block crashes.

Note 2: When the BIOS recovery block crashes, you will need to follow the procedures to make a Returned Merchandise Authorization (RMA) request. (For a RMA request, please see section 3.5 for more information). Also, you may use the Supermicro Update Manager (SUM) Out-of-Band (OOB) (https://www.supermicro.com.tw/products/nfo/SMS_SUM.cfm) to reflash the BIOS.

D.3 Recovering the Main BIOS Block with a USB Device

This feature allows the user to recover the main BIOS image using a USB-attached device without additional utilities used. A USB flash device such as a USB Flash Drive, or a USB CD/DVD ROM/RW device can be used for this purpose. However, a USB Hard Disk drive cannot be used for BIOS recovery at this time.

The file system supported by the recovery block is FAT (including FAT12, FAT16, and FAT32) which is installed on a bootable or non-bootable USB-attached device. However, the BIOS might need several minutes to locate the SUPER.ROM file if the media size becomes too large due to the huge volumes of folders and files stored in the device.

To perform UEFI BIOS recovery using a USB-attached device, follow the instructions below.

1. Using a different machine, copy the "Super.ROM" binary image file into the Root "\\" directory of a USB device or a writable CD/DVD.

Note: If you cannot locate the "Super.ROM" file in your drive disk, visit our website at www.supermicro.com to download the BIOS package. Extract the BIOS binary image into a USB flash device and rename it "Super.ROM" for the BIOS recovery use.

2. Insert the USB device that contains the new BIOS image ("Super.ROM") into your USB drive and reset the system when the following screen appears.



3. After locating the healthy BIOS binary image, the system will enter the BIOS Recovery menu as shown below.

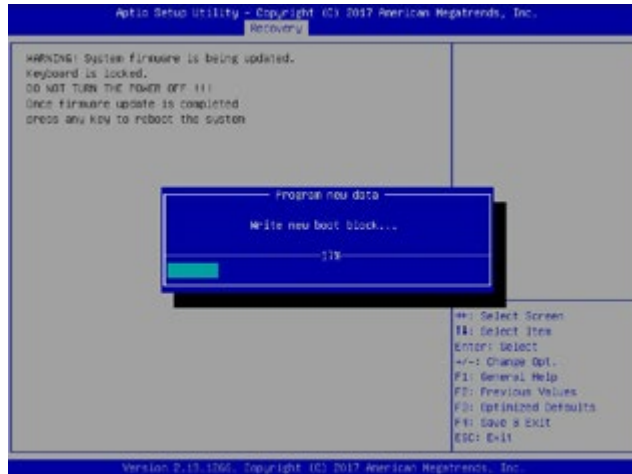

Note: At this point, you may decide if you want to start the BIOS recovery. If you decide to proceed with BIOS recovery, follow the procedures below.

4. When the screen as shown above displays, use the arrow keys to select the item "Proceed with flash update" and press the <Enter> key. You will see the BIOS recovery progress as shown in the screen below.

Note: *Do not interrupt the BIOS flashing process until it has completed.*

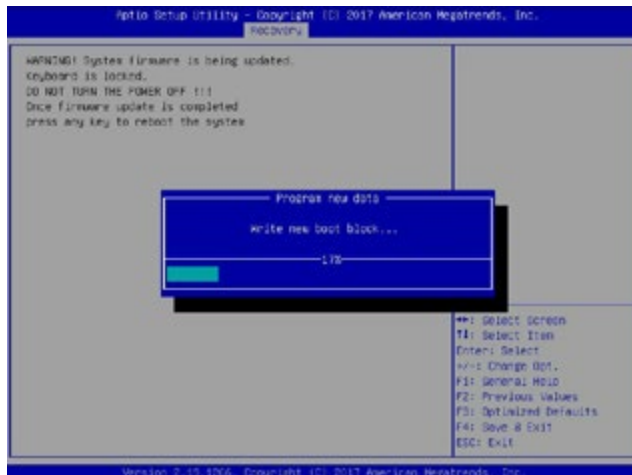

5. After the BIOS recovery process is complete, press any key to reboot the system.

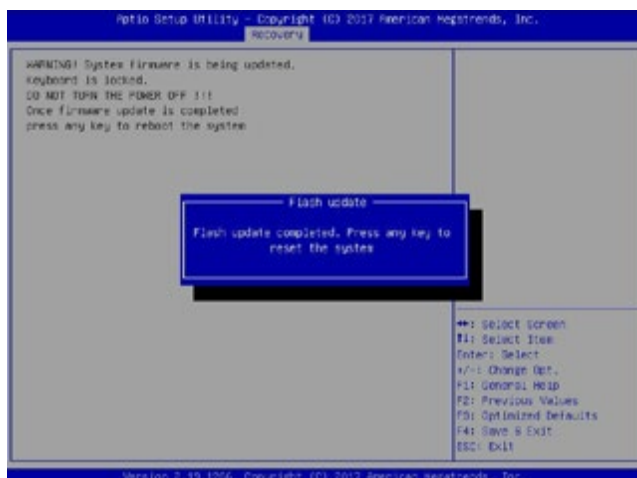

6. Using a different system, extract the BIOS package into a USB flash drive.

7. Press continuously during system boot to enter the BIOS Setup utility. From the top of the tool bar, select Boot to enter the submenu. From the submenu list, select Boot Option #1 as shown below. Then, set Boot Option #1 to [UEFI AP:UEFI: Built-in EFI Shell]. Press <F4> to save the settings and exit the BIOS Setup utility.

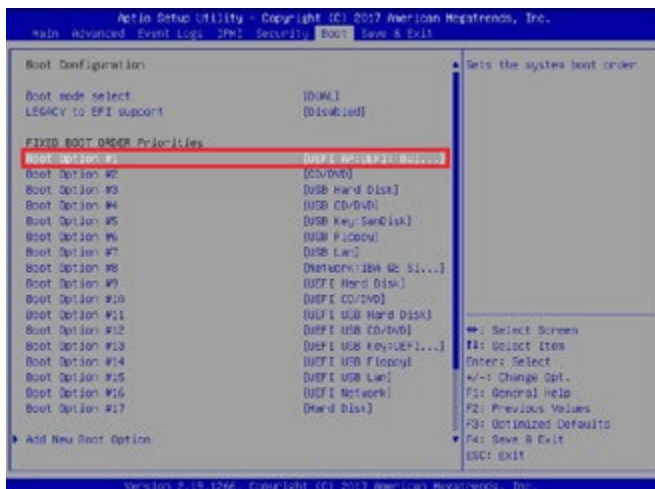

- When the UEFI Shell prompt appears, type `fs#` to change the device directory path. Go to the directory that contains the BIOS package you extracted earlier from Step 6. Enter `flash.nsh BIOSName.###` at the prompt to start the BIOS update process.

```

UEFI Interactive Shell v1.1
UEFI: FS#
UEFI: FS# (American Megatrends, sub0000000)
Reading file:
File: F:\BIOS\AMIBIOS\BIOS.###
Path: F:\BIOS\AMIBIOS\BIOS.###\AMIBIOS.###\AMIBIOS.###\BIOS.###
(AMIBIOS)
Block: AMIBIOS()
Path: F:\BIOS\AMIBIOS\BIOS.###\AMIBIOS.###\AMIBIOS.###
Press ESC to 3 seconds to skip startup.nsh or any other key to continue.
Shell: FS#
FS#> cd /BIOS
FS#> cd AMIBIOS
FS#> flash.nsh BIOSName.###

```

Note: *Do not interrupt this process* until the BIOS flashing is complete.

```

Done.
[ Access BIOS Port Ex ]
Done
Index Out: In:0

Done.
-----
+ Program BIOS and ME (Including FDT Package)...
-----
AMT Firmware Update Utility v5.07.01.0117
Copyright (C)2017 American Megatrends Inc. All Rights Reserved.
-----
SPUD = 30902

Reading Flash ..... done
- MC Data Size Checking - ok
- FPD (Prologue) ..... ok
- Check Non-volatile ..... ok
- Creating Boot Block ..... done
- Updating Boot Block ..... done
- Verifying Boot Block ..... done
- Creating Main Block ..... (0x00000000-000)

```

- The screen above indicates that the BIOS update process is complete. When you see the screen above, unplug the AC power cable from the power supply, clear CMOS, and plug the AC power cable in the power supply again to power on the system.

```

Verifying MTD Block ..... done
- Update success for FDB
- Update success for IL
- Successful update Recovery Loader to 09x01
- Successful update MFB
- Successful update FPH
- Successful update M2, ZBI and ZBI01
- Successful update PLO and U7001
+ ME Update Done Update success !!
WARNING: System not down-off to have the changes take effect!
moving F:\NF\LOAD\SMART_01102021\F0164_01 -> F:\NF\LOAD\SMART_01102021\F0164_01
(0_000)
- OK
moving F:\NF\LOAD\SMART_01102021\F0164_01 -> F:\NF\LOAD\SMART_01102021\F0164_01
- OK
-----
+ Please ignore this "Shell: Cannot read from file - Device Error"
+ warning message due to it does not affect flashing process.
-----
Deleting .....
Deleting .....
DELETE successful.
FS#>

```

- Press `` continuously to enter the BIOS Setup utility.
- Press `<F3>` to load the default settings.
- After loading the default settings, press `<F4>` to save the settings and exit the BIOS Setup utility.