

Installation and Quick Configuration

NetBotz® Rack Monitor 750

NBRK0750

990-91106E-001

Publication Date: 5/2020

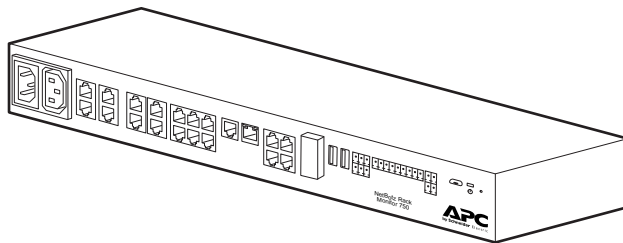

APC by Schneider Electric Legal Disclaimer

The information presented in this manual is not warranted by APC by Schneider Electric to be authoritative, error free, or complete. This publication is not meant to be a substitute for a detailed operational and site specific development plan. Therefore, APC by Schneider Electric assumes no liability for damages, violations of codes, improper installation, system failures, or any other problems that could arise based on the use of this Publication.

The information contained in this Publication is provided as is and has been prepared solely for the purpose of evaluating data center design and construction. This Publication has been compiled in good faith by APC by Schneider Electric. However, no representation is made or warranty given, either express or implied, as to the completeness or accuracy of the information this Publication contains.

IN NO EVENT SHALL APC BY SCHNEIDER ELECTRIC, OR ANY PARENT, AFFILIATE OR SUBSIDIARY COMPANY OF APC BY SCHNEIDER ELECTRIC OR THEIR RESPECTIVE OFFICERS, DIRECTORS, OR EMPLOYEES BE LIABLE FOR ANY DIRECT, INDIRECT, CONSEQUENTIAL, PUNITIVE, SPECIAL, OR INCIDENTAL DAMAGES (INCLUDING, WITHOUT LIMITATION, DAMAGES FOR LOSS OF BUSINESS, CONTRACT, REVENUE, DATA, INFORMATION, OR BUSINESS INTERRUPTION) RESULTING FROM, ARISING OUT, OR IN CONNECTION WITH THE USE OF, OR INABILITY TO USE THIS PUBLICATION OR THE CONTENT, EVEN IF APC BY SCHNEIDER ELECTRIC HAS BEEN EXPRESSLY ADVISED OF THE POSSIBILITY OF SUCH DAMAGES. APC BY SCHNEIDER ELECTRIC RESERVES THE RIGHT TO MAKE CHANGES OR UPDATES WITH RESPECT TO OR IN THE CONTENT OF THE PUBLICATION OR THE FORMAT THEREOF AT ANY TIME WITHOUT NOTICE.

Copyright, intellectual, and all other proprietary rights in the content (including but not limited to software, audio, video, text, and photographs) rests with APC by Schneider Electric or its licensors. All rights in the content not expressly granted herein are reserved. No rights of any kind are licensed or assigned or shall otherwise pass to persons accessing this information.

This Publication shall not be for resale in whole or in part.

Contents

Important Safety Information.....	1
Please Note	1
Safety Information for the NetBotz Rack Monitor 750	2
General Information	3
Product Description	3
Additional Options	3
Updates and Related Documents.	3
Inventory.	4
Physical Description	5
Status LED	6
Link LED (Public LAN)	6
Link LED (Private LAN)	6
Care and Disposal	6
Installation.....	7
Cage Nuts.	7
Installation	7
Removal	7
Install the Rack Monitor 750	8
Connect the Power Cord and Network Cable.	9
Engage and disengage the C-14 locking connector	9
Engage and disengage the C-13 locking connector	9
Connect Sensors and Devices	10
Cascade sensors and sensor pods on A-Link ports	11
Connect a wireless sensor network	12
Initial Configuration	13
Use DHCP to Establish Network Settings	13
Use Your Computer to Establish Network Settings	14
Use a Terminal Emulator to Establish Network Settings	15
Access the Appliance	15
Types of user accounts	16
Reset a lost Super User password	16
Reset a lost Root account password	16
Reset to defaults	17
Discover Downstream Devices.	17
Configure a Wireless Sensor Network	18
Configure Outlet-controlled Devices.	18
Update the Firmware	18
Specifications.....	19
Sensor Specifications	20
Two-Year Factory Warranty	21
Terms of warranty	21
Non-transferable warranty	21
Exclusions	21
Warranty claims	22

Important Safety Information

Read the instructions carefully to become familiar with the equipment before trying to install, operate, service or maintain it. The following messages may appear throughout this manual or on the equipment to warn of potential hazards or to call attention to information that clarifies or simplifies a procedure.



The addition of this symbol to a Danger or Warning safety label indicates that an electrical hazard exists which will result in personal injury if the instructions are not followed.



This is the safety alert symbol. It is used to alert you to potential personal injury hazards. Obey all safety messages that follow this symbol to avoid possible injury or death.

DANGER

DANGER indicates an imminently hazardous situation which, if not avoided, **will result in** death or serious injury.

WARNING

WARNING indicates a potentially hazardous situation which, if not avoided, **can result in** death or serious injury.

CAUTION

CAUTION indicates a potentially hazardous situation which, if not avoided, **can result in** minor or moderate injury.

NOTICE

NOTICE addresses practices not related to physical injury including certain environmental hazards, potential damage or loss of data.

Please Note

Electrical equipment should be installed, operated, serviced, and maintained only by qualified personnel. No responsibility is assumed by APC by Schneider Electric for any consequences arising out of the use of this material.

A qualified person is one who has skills and knowledge related to the construction, installation, and operation of electrical equipment and has received safety training to recognize and avoid the hazards involved.

Safety Information for the NetBotz Rack Monitor 750

⚠ ⚠ DANGER

HAZARD OF ELECTRIC SHOCK, EXPLOSION, OR ARC FLASH

- No user-serviceable parts inside. Refer servicing to qualified personnel.
- Use indoors only in a dry location.
- Ensure the power input for the Rack Monitor 750 has a reliable ground (earth) connection.
- The Rack Monitor 750 is intended to be installed and operated by a skilled person in a controlled location with restricted access.
- The switched outlet may have voltage potential when the outlet is set to "off." Always use a properly rated voltage sensing device to confirm there is no voltage in the outlet.
- Disconnect the load power cord from this product before servicing the load equipment or the power cord.

Failure to follow these instructions will result in death or serious injury.

⚠ WARNING

UNEXPECTED EQUIPMENT OPERATION

Use only properly rated and certified power cords with this appliance.

Failure to follow these instructions can result in death or serious injury.

⚠ CAUTION

FALLING EQUIPMENT HAZARD

- Do not create a hazardous condition due to uneven mechanical loading. For example, do not use the appliance as a shelf.
- Ensure the Rack Monitor 750 is mounted securely and evenly.

Failure to follow these instructions can result in injury or equipment damage.

NOTICE

EQUIPMENT DAMAGE HAZARD

The ambient operating temperature of a closed or multi-unit rack environment may be greater than the ambient temperature of the room. Ensure the ambient operating temperature of your rack environment does not exceed the rated ambient operating temperature for the Rack Monitor 750.

Failure to follow these instructions can result in equipment damage.

The Rack Monitor 750 is suitable for installation in Information Technology Rooms in accordance with Article 645 of the National Electric Code and NFPA 75.

General Information

The *NetBotz® Rack Monitor 750 Installation and Quick Configuration Manual* describes how to install a NetBotz Rack Monitor 750, connect devices to the appliance, and configure network settings. After performing the configuration procedures in this manual, you can access your system through a Web User Interface (UI), perform additional configuration tasks, and begin monitoring the environment.

Product Description

The APC by Schneider Electric™ NetBotz Rack Monitor 750 functions as the central hardware appliance for a NetBotz security and environmental monitoring system. The rack-mountable appliance includes the following features:

- Multiple ports for connecting APC by Schneider Electric and third party sensors and devices
- Ports that provide power to or allow control over other devices
- The ability to add sensor pods to increase monitored space

Additional Options

The following sensors and devices are compatible with the Rack Monitor 750. For more information about any of these options, contact your APC by Schneider Electric representative or the distributor from whom you purchased your APC by Schneider Electric product.

- NetBotz Rack Sensor Pod 150 (NBPD0150)
- NetBotz Room Sensor Pod 155 (NBPD0155)
- NetBotz Camera Pod 165 (NBPD0165)
- NetBotz Rack Access Pod 170 (NBPD0171, NBPD0172)
- NetBotz Rack Access Handle Kit (NBHN125, NBHN1356)
- Temperature Sensor (AP9335T)
- Temperature/Humidity Sensor (AP9335TH)
- Temperature/Humidity Sensor with Digital Display (AP9520TH)
- Alarm Beacon (AP9324)
- NetBotz Spot Fluid Sensor (NBES0301)
- NetBotz Door Switch Sensor for Rooms or Third Party Racks (NBES0302)
- NetBotz Door Switch Sensor for APC by Schneider Electric Racks (NBES0303)
- NetBotz Dry Contact Cable (NBES0304)
- NetBotz 0-5 V Sensor Cable (NBES0305)
- NetBotz Vibration Sensor (NBES0306)
- NetBotz Smoke Sensor (NBES0307)
- NetBotz Leak Rope Sensor (NBES0308)
- NetBotz Leak Rope Extension (NBES0309)
- NetBotz USB Coordinator & Router (NBWC100U)
- NetBotz Wireless Temperature Sensor (NBWS100T and NBWS100H)

Updates and Related Documents

You can find updates to this document, the *User Guide*, *Release Notes*, and *Security Handbook* on the applicable product page of the APC by Schneider Electric website, www.apc.com.

Inventory

Inspect the package and contents for shipping damage. Make sure all parts were sent. Immediately report any shipping damage to the shipping agent. Report missing contents, product damage, or other problems with the product to APC by Schneider Electric or your Schneider Electric reseller.

The shipping and packaging materials are recyclable. Please save them for later use or dispose of them appropriately.

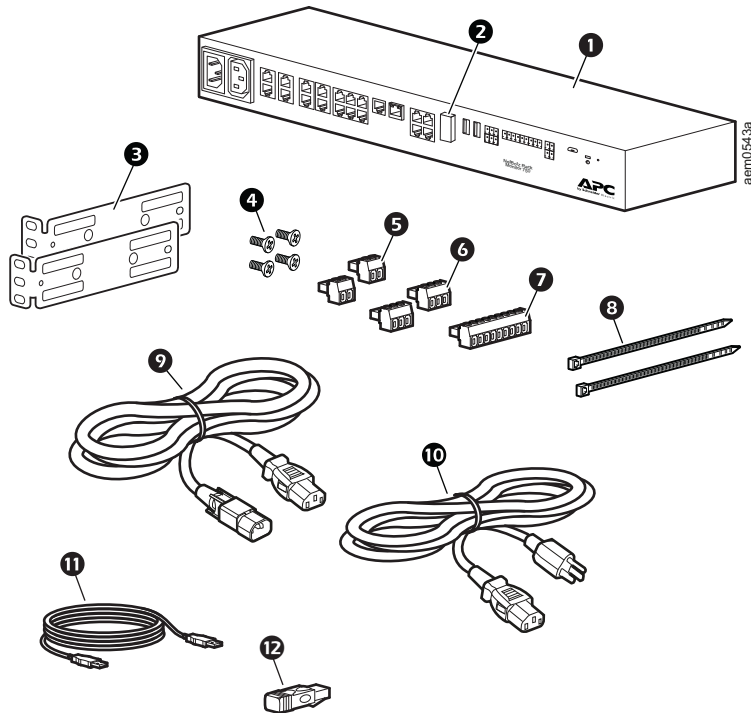

Item	Description	Quantity
1	NetBotz Rack Monitor 750	1
2	Wireless Coordinator & Router (NBWC100U)	1
3	Brackets for a standard 19-in rack	2
4	Phillips flat head screws, M4 x 8	4
5	2-position terminal block plug	2
6	3-position terminal block plug	2
7	9-position terminal block plug	1
8	Tie wraps, 203 mm (8 in)	2
9	IEC-320-C13 to IEC-320-C14 power cord, 1.8 m (6 ft)	1
10	NEMA 5-15P to IEC-320-C13 power cord. 1.8 m (6 ft)	1
11	USB-A to Micro USB-B cable, 2 m (6 ft)	1
12	A-Link Terminator	1

Not Shown:

- Temperature/Humidity Sensor (AP9335TH)
- Wireless temperature sensor (NBWS100T)
- Base mount hardware kit (0M-814726)

Physical Description

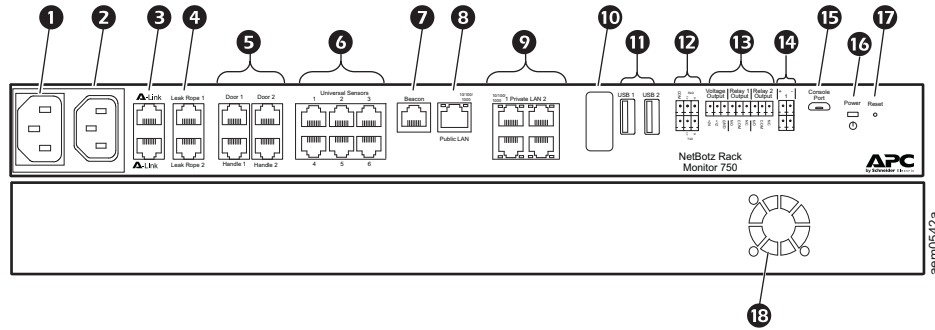

Item	Description
1	AC line inlet Input power connection. See “Specifications” on page 19 for voltage information.
2	Switched Outlet Provides power to a device at a maximum of 10 A. Activates a connected device when configured events occur. (For example, a fan may be connected to this outlet, and the outlet may be configured to turn on when certain alarms are generated.)
3	A-Link ports Used to cascade NetBotz sensor pods, rack access pods, and temperature and humidity sensors with digital displays. Provide communications and power to the connected devices over standard CAT-5 cabling with straight-through wiring. For details, see “Cascade sensors and sensor pods on A-Link ports” on page 11.
4	Leak Rope port Used for connecting a NetBotz Leak Rope Sensor (NBES0308)
5	Rack Access ports Ports for the door switch sensors and handle sensors (NBHN125 or NBHN1356). See the <i>User Guide</i> on www.apc.com for instructions to set up rack access.
6	Universal Sensor ports Used to connect APC by Schneider Electric sensors, third-party dry-contact sensors, and standard third-party 0–5 V sensors. (See “Connect Sensors and Devices” on page 10 for details.) Third-party dry-contact state sensors require the NetBotz Dry Contact Cable (NBES0304), and third-party 0–5 V sensors require the NetBotz 0–5 V sensor cable (NBES0305).
7	Beacon port Used for connecting an Alarm Beacon (AP9324).
8	10/100/1000 Network port Provides a connection to the network. Status and link LEDs indicate network traffic. See “Status LED” on page 6 and “Link LED (Public LAN)” on page 6.
9	Private LAN* PoE+ type 2 port (IEEE802.3at). Provides a 10/100/1000 connection to a private Local Area Network (LAN). Each port can provide up to 25.5 W to attached devices.
10	Wireless Sensor Coordinator USB port with Wireless NetBotz USB Coordinator (NBWC100U) installed. Used with wireless sensors.
11	USB Type A ports Reserved for future use.
12	Modbus RS485 port Reserved for future use.
13	Voltage Output Provides 12 VDC or 24 VDC (75 mA) to one connected device.
	Relay Output ports Used for connecting relay-controlled external devices. NOTE: Only connect Relay Outputs to Class 2 circuits.
14	4-20 mA Inputs Inputs for industry standard 4–20 mA sensors.
15	Console port Provides a serial connection to the appliance.
16	Power LED Illuminates when the unit is receiving power.
17	Reset switch Reboots the appliance.
18	Exhaust fan Exhausts hot air from the appliance.

*If you use a Network hub or switch to connect more than one device to a single Private LAN port, consider providing a power source for each connected device.

Status LED

The LED (light-emitting diode) on the left side of any network port indicates the status of the Rack Monitor 750.

Condition	Description
Off	One of the following situations exists: <ul style="list-style-type: none">•The Rack Monitor is not receiving input power.•The Rack Monitor is not operating properly. It may need to be repaired or replaced. Contact Customer Support at www.apc.com/support.
Alternately flashing green and amber	The Rack Monitor 750 is waiting for a DHCP server to assign a valid IP address.
Solid green	The Rack Monitor 750 is on and has a valid IP address.

Link LED (Public LAN)

The LED on the right of the 10/100/1000 network port indicates the network status of the Rack Monitor 750.

Condition	Description
Off	One or more of the following situations exist: <ul style="list-style-type: none">•The Rack Monitor is not receiving input power.•The cable that connects the Rack Monitor to the network is disconnected or not functioning properly.•The Rack Monitor is turned off or not operating correctly. It may need to be repaired or replaced. Contact Customer Support at www.apc.com/support.
Solid green	The Rack Monitor is connected to a network operating at 100 Megabits (Mb) per second or 1000 Mb/1Gigabits (Gb) per second.
Solid orange	The Rack Monitor is connected to a network operating at 10 Mb per second.
Flashing green	The Rack Monitor is receiving or transmitting data packets at 1 Gb per second.
Flashing orange	The Rack Monitor is receiving or transmitting data packets at 10 Mb or 100 Mb per second.

Link LED (Private LAN)

The LEDs on the right of the Private LAN ports indicate the network status of devices connected to the Rack Monitor 750.

Condition	Description
Off	One or more of the following situations exist: <ul style="list-style-type: none">•The Rack Monitor is not receiving input power.•The cable that connects the Rack Monitor to the network is disconnected or not functioning properly.•The Rack Monitor is turned off or not operating correctly. It may need to be repaired or replaced. Contact Customer Support at www.apc.com/support.
Solid green	The device is connected to a network.
Flashing green	The device is receiving or transmitting data packets.

Care and Disposal

To clean the Rack Monitor 750, gently wipe its surfaces with a clean, dry cloth.

NetBotz Rack Monitor appliances contain non-replaceable, lithium coin-cell batteries. Do not attempt to replace the battery. Please take the battery into consideration when disposing of the appliance.

Installation

NOTICE

Appliances installed in a closed or multi-unit rack assembly can experience a greater ambient operating temperature than the ambient room temperature. Install the appliance in a way that allows sufficient airflow for safe operation.

Install the appliance in an environment compatible with the maximum ambient temperature (see “Specifications” on page 19).

Cage Nuts

If needed, APC by Schneider Electric offers a cage nut hardware kit (AR8100) for use with square holes.

⚠ CAUTION

FALLING EQUIPMENT HAZARD

Do NOT install cage nuts vertically with the ears engaging the top and bottom of the square hole.

Failure to follow these instructions can result in minor or moderate injury.

- Install cage nuts horizontally, with the ears engaging the sides of the square hole.
- Install the cage nuts on the interior of the vertical mounting rail.

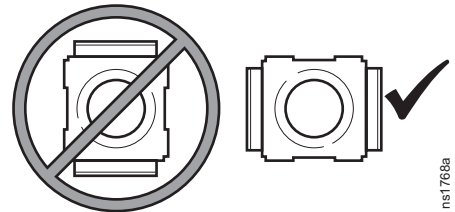

Installation

1. From inside of the cabinet, insert the cage nut into the square hole. Hook one ear of the cage nut assembly through the far side of the hole.
2. Place the cage nut tool on the other side of the cage nut and pull to snap into position.

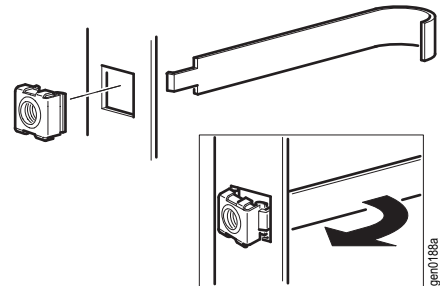

Removal

1. Remove any attached screw.
2. Grasp the cage nut and squeeze the sides to release it from the square hole.

Install the Rack Monitor 750

NOTICE

Use only the provided hardware to install the brackets.

The appliance requires 1 U of rack space.

1. Choose a location for the appliance in the front or rear of the rack. The appliance occupies one U-space. A notched hole or a number on the vertical mounting rail denotes the middle of a U-space.

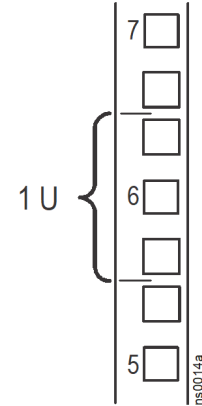

2. Use the provided M4 x 8 Phillips flat head screws (1) to install the brackets (2) on the appliance.

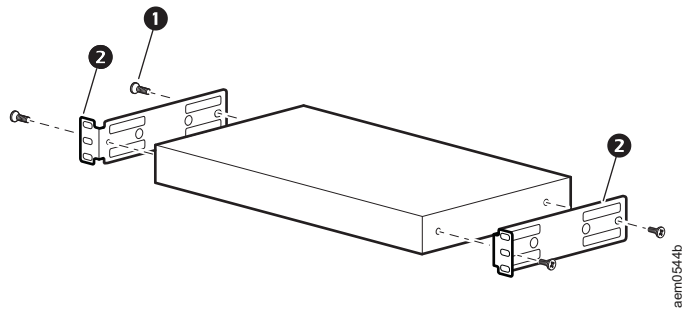

3. Secure the appliance to the rack, using cage nuts and screws (not provided).

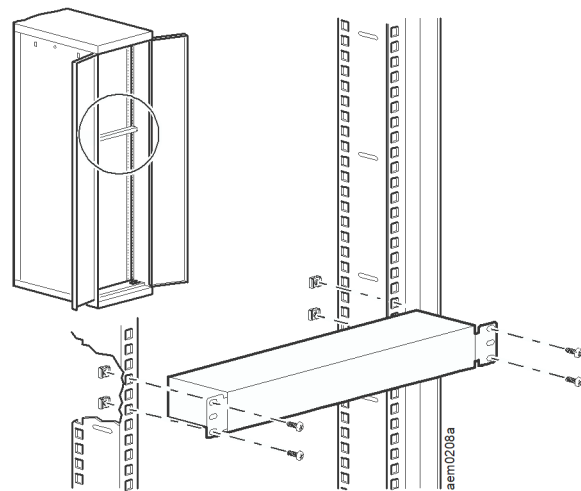

Connect the Power Cord and Network Cable

NOTICE

Before you apply power to the appliance, see “Specifications” on page 19 to avoid overloading the circuit. Make sure you properly ground the appliance: either plug the power cord directly into a wall outlet, or verify the ground path if using a power strip.

Use only the provided power cords with APC by Schneider Electric NetBotz products.

1. Connect the appropriate power cord to the AC Line Inlet of the appliance.
2. Connect a network cable to the 10/100/1000 Network port on the appliance.
3. Plug the power cord into a power source.

Engage and disengage the C-14 locking connector

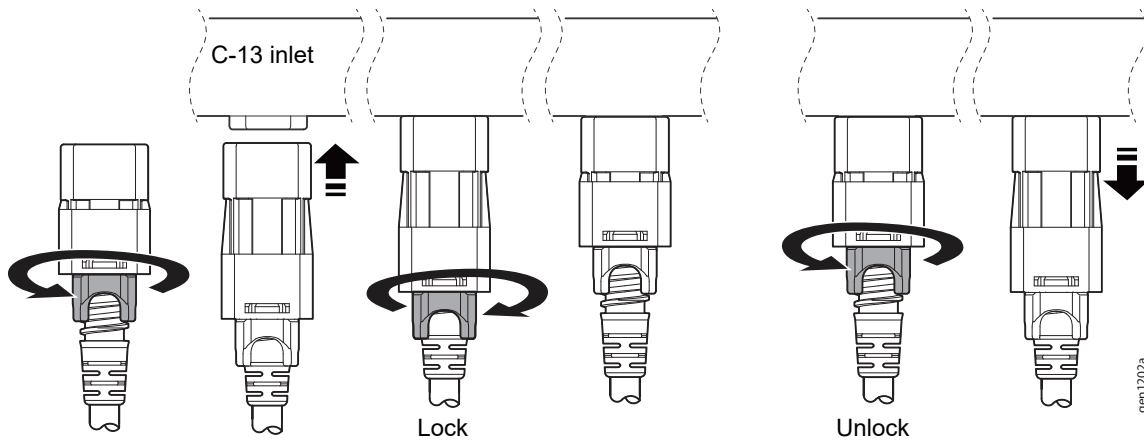

Engage and disengage the C-13 locking connector

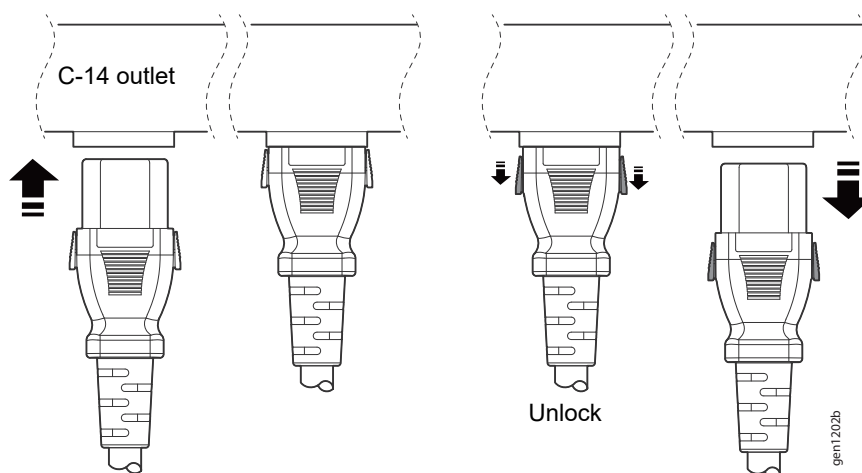

Connect Sensors and Devices

NOTICE

- Only connect approved devices to the correct ports on the appliance as directed in this manual. Plugging in other devices may result in equipment damage.
- Do not connect handles from NBHN125 or NBHN1356 to a Rack Access Pod.
- Do not connect handles that come with a Rack Access Pod to the Rack access ports on your appliance.

Sensor/Device	Port/connection requirements
Alarm beacon AP9324	Beacon port*
Door switch sensors •NBES0302 •NBES0303	Universal sensor ports or Rack Access ports (Door #1 and Door #2). NOTE: When using both a handle kit and a door switch sensor, connect the door switch sensor to a Rack Access port.
Downstream devices •Camera Pod 165 (NBPD0165) •Rack PDUs with Network Management Card 2 (NMC2) •UPS units with NMC2	Private LAN port. NOTE: The discovery settings must match the downstream device settings, or the devices will not be discovered. See "Discover Downstream Devices" on page 17. NOTE: You can use a network switch or hub to connect up to ten downstream devices, including up to four Camera Pod 165 units.
Handle kits •NBHN125 •NBHN1356	Rack Access ports: Handle #1 and Handle #2
Rack Access Pods** •NBPD0171 •NBPD0172	A-Link ports†
Sensor Pods •Sensor Pod150 (NBPD0150) •Sensor Pod 155 (NBPD0155)	A-Link ports†
Temperature sensors •Temperature/Humidity Sensor with Display (AP9520TH) •Temperature Sensor (AP9335T) •Temperature/Humidity Sensor (AP9335TH)	A-Link ports† Universal sensor ports
Other NetBotz Sensors •Vibration Sensor (NBES0306) •Smoke Sensor (NBES0307) •Spot Fluid Sensor (NBES0301) •0–5 V Sensor Cable (NBES0305) •Dry Contact Cable (NBES0304)	Universal sensor ports
Third-party 0–5 V sensors	Standard third-party 0-5 V sensors require the NetBotz 0–5 V Sensor Cable (NBES0305). To connect a sensor to the cable, follow the instructions provided with the sensor and the instructions provided with the cable.
Third-party dry contact sensors	Third-party dry contact sensors require the NetBotz Dry Contact Cable (NBES0304). To connect a sensor to the cable, follow the instructions provided with the sensor and the instructions provided with the cable.

*See "Configure Outlet-controlled Devices" on page 18 for basic configuration.

**See the *User Guide* on www.apc.com for instructions to configure rack access.

†See "Cascade sensors and sensor pods on A-Link ports" on page 11 to cascade sensors and sensor pods.

NOTE: 1. You can also connect sensors to the universal sensor ports on a Sensor Pod 150 or 155.

2. If a sensor cable is not long enough, use an RJ-45 coupling (provided with some sensors) and standard CAT-5 cabling to extend the cable up to 15 m (50 ft) for a Temperature/Humidity Sensor (AP9335TH) or a Temperature Sensor (AP9335T), and up to 30.5 m (100 ft) for all other supported sensors.

Cascade sensors and sensor pods on A-Link ports

NOTICE

- Do not use crossover cables.
- Do not cascade appliances. Use one appliance per system.
- Do not connect A-Link devices to an Ethernet bus.

Before performing this procedure, follow the installation instructions provided with the devices you plan to cascade. You can cascade any or all of the following:

- A combined total of twelve NetBotz Rack Sensor Pod 150s (NBPD0150) and NetBotz Room Sensor Pod 155s (NBPD0155),
- A combined total of eight Temperature Sensors with Digital Display (AP9520T) and Temperature/Humidity Sensors with Digital Display (AP9520TH).
- Up to thirteen Rack Access Pods (NBPD0171, NBPD0172). If you cascade more than four Rack Access Pods, you will need one supplemental power supply (AP9505i) for every four pods.

A-Link is an APC by Schneider Electric proprietary Controller Area Network (CAN) bus. Devices compatible with A-Link are not Ethernet devices and cannot coexist on an Ethernet bus with other networking devices, such as hubs and switches.

To connect sensors and sensor pods to A-Link ports,

1. Connect sensors and sensor pods to the appliance as shown.
 - Use CAT-5 (or equivalent) Ethernet patch cables (2)
 - Connect to **in** and **out** ports as shown.
 - The combined length of all A-Link cables (1) must not exceed 1000 m (3,280 ft).
2. Plug an A-Link terminator into the unused A-Link port (3).
3. If you cascade four or more Rack Access Pods, connect one supplemental power supply (AP9505i) to the 24 VDC Input jack on every fourth Rack Access Pod.
NOTE: The first time a sensor pod receives power, it obtains a unique identification address for communication over the A-Link bus. To avoid communication problems, complete steps 1 and 2 before you connect a supplemental power supply.

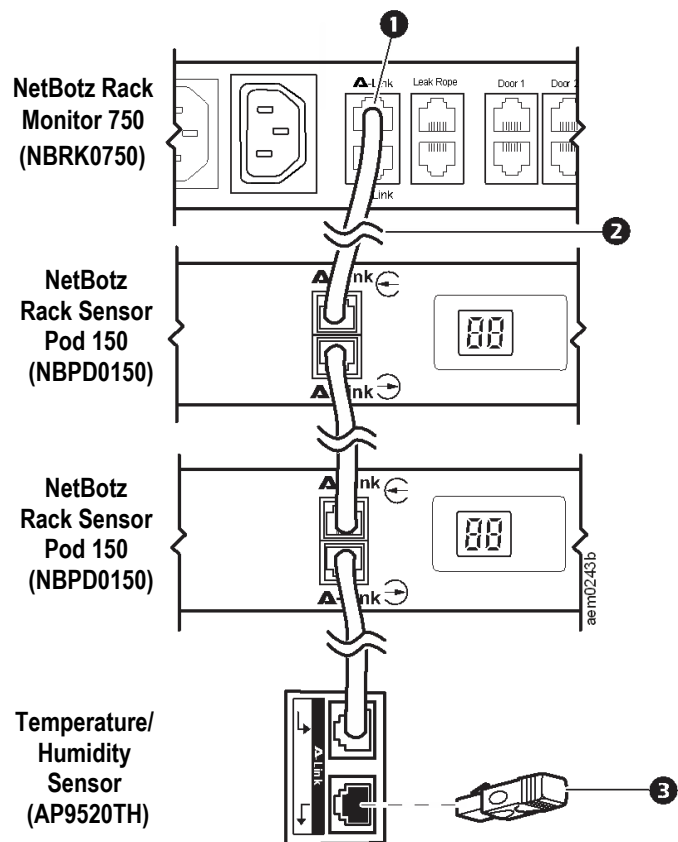

Connect a wireless sensor network

NOTICE

Only the devices listed here are compatible with the NetBotz wireless sensor network. Other devices may not function and may damage the appliance and other wireless devices.

The wireless sensor network is made of a host appliance, a coordinator, routers, and end devices.

- The **host appliance** (the Rack Monitor 750) collects data from the wireless sensor network and generates alerts based on sensor readings.
- The **coordinator** is connected directly to the host appliance via USB. It reports data from the sensors on the network and provides available firmware updates to the wireless network. Each wireless sensor network must have only one coordinator, which is connected to a USB Type A port on the NetBotz appliance.
- **Routers** extend the range of the wireless sensor network. Routers pass information between themselves and the coordinator, and between the coordinator and end devices. Routers are optional. In a data center environment where obstructions are common, routers are recommended if sensors are more than 50 feet from the coordinator. Each router is powered by an AC-USB adapter, not directly connected to the NetBotz appliance.
- **End devices** monitor attached and internal sensors and send data back to the host appliance through the network. End devices are powered by batteries.

The following devices can be configured on your wireless network:

Wireless device	Network role
USB Coordinator & Router (NBWC100U)	coordinator when connected to the appliance router when powered by an AC-USB adapter
Wireless Temperature Sensor (NBWS100T)	end device
Wireless Temperature/Humidity Sensor (NBWS100H)	end device

NOTE: Wireless sensors have a maximum, line-of-sight range of 30.5 m (100 ft). In a data center environment where obstructions are common, a range of 15 m (50 ft) is typical.

The order in which you configure your wireless sensor network and apply power to your wireless devices is important:

1. **Select the coordinator and routers:** Choose the USB Coordinator & Router that will become the coordinator. Note the extended address of the coordinator. Choose one or more USB Coordinator & Routers to become routers.
2. **Mount the sensors.** Choose the locations for the routers and end devices. Do not power the routers or end devices at this time.
3. **Power the coordinator first:** Connect one USB Coordinator & Router to a USB Type A port on the NetBotz appliance.
4. **Power the routers:** Connect each router to an AC-USB adapter, not the NetBotz appliance.
5. **Power the end devices:** To preserve battery life, do not power the end devices until after the coordinator and the routers are powered.
6. **Configure your appliance.** See “Initial Configuration” on page 13, then complete the configuration of the wireless network on the Web UI of your appliance (see “Configure a Wireless Sensor Network” on page 18).

For detailed information about installing and configuring your wireless devices, see the installation manual for each device.

Initial Configuration

You must configure the following TCP/IP settings before the appliance can operate on a network:

- IP address of the appliance
- Subnet mask
- Default gateway
- At least one IP address for a Domain Name System (DNS) server

You can use DHCP to configure network settings automatically, or use your computer to configure network settings manually (Windows systems only). If needed, you can also view or configure network settings with a terminal emulator.

NOTE: It is recommended that you update to the latest firmware version after initial configuration.

Use DHCP to Establish Network Settings

By default, your appliance looks for a properly configured DHCP server to configure the network settings. When you apply power to the appliance, it automatically attempts to contact a DHCP server.

If the DHCP server is configured to provide a host name, the appliance requests its configured host name as a host name associated with the IP address granted by the DHCP server. The appliance also requests DNS server addresses, a DNS domain, and NTP server addresses from the DHCP server.

Use Your Computer to Establish Network Settings

NOTE: This procedure is only for Windows operating systems.

1. Ensure your computer is set to obtain network settings via DHCP. Connect a network cable from your computer to one Private LAN ports on the appliance.
2. Use the Public LAN port to connect your appliance to the network.
3. Open a command prompt and enter the following two commands:

```
ipconfig /release  
ipconfig /renew
```

4. The command prompt should provide an IP, subnet mask, and default gateway. Open a Web browser and enter the default gateway in the URL address bar.
5. Use the default user name and password (both are **superuser**) to log on to the appliance, and change the password when prompted. Use a strong password that complies with your company's password requirements.
6. Go to **Settings > System > Network** to view or configure the network settings for your appliance.

Setting	Description
Static	Select Static to manually configure your Network settings. This setting assigns a static IP address to the appliance.
DHCP	Use a DHCP server to configure network settings automatically. This setting assigns a dynamic IP address to the appliance.
Hostname	The host name of the appliance.
TCP/IP	
IP Address	The IP address of the appliance. Use the format xxx.xxx.xxx.xxx.
Subnet Mask	The subnet mask of the appliance.
Gateway	The IP address of the default gateway.
DNS	
Primary	The IP address of the primary DNS server.
Secondary	The IP address of the secondary DNS server.
Tertiary	The IP address of the tertiary DNS server.

NOTE: You may receive a message that the Web page is not secure. This is normal, and you can continue to the Web UI. See "Access the Appliance" on page 15 for more information.

Use a Terminal Emulator to Establish Network Settings

1. Connect a USB-A to Micro USB-B cable to the Console port on the NetBotz appliance and a USB port on your computer.
2. Plug the power cord provided with your NetBotz appliance into a wall outlet, and then connect it to the AC line inlet.
The green Power LED illuminates. The appliance can take up to two minutes to initialize, depending on configuration settings.
3. Open a serial connection on your terminal emulator and configure the port settings with 115,200 baud, 8 data bits, no parity, 1 stop bit, and no flow control.
4. Press ENTER, repeatedly if necessary, to display the **User Name** prompt. If you are unable to display the **User Name** prompt, verify the following:
 - The serial port is not in use by another application.
 - The terminal settings are correct as specified in step 3.
 - The correct cable is being used as specified in step 2.
 - The Silicon Labs CP210x USB to UART Bridge VCP Driver is installed on your computer. (You can find the driver on www.silabs.com.)
5. Log on with the Root account user name (**root**) and password (you set the password on first use).
6. Configure your appliance to use network settings assigned by a DHCP server, or provide an IP address, subnet mask, and gateway address, and at least one IP address for a DNS server. See the *User Guide* on www.apc.com for details.
7. Save your configuration settings, and close the terminal emulator.
8. Test the IP connection of the NetBotz appliance: start your Web browser and type the appliance's IP address into the address field. Press ENTER. If the appliance is online and properly configured, the Web UI displays in the browser window.

NOTE: You may receive a message that the Web page is not secure. This is normal, and you can continue to the Web UI. See “Access the Appliance” on this page for more information.

Access the Appliance

After the network settings are configured, you can access the appliance through the Web UI. The Web UI provides a real-time overview of alerts and device details, including sensor readings and images captured by cameras.

You can connect to the Web UI using Google Chrome, Mozilla Firefox, and Microsoft Internet Explorer. To log on to the Web UI, enter `https://appliance_hostname_or_IP_address` in the Web browser's URL address field.

You may receive a message that the Web page is not secure. This is normal, and you can continue to the Web UI. The warning is generated because your Web browser does not automatically trust the default certificate used for encryption over HTTPS. However, information transmitted over HTTPS is still encrypted. See the *User Guide* and *Security Handbook* on www.apc.com for more details on HTTPS certificates and instructions to resolve the warning.

NOTE: If you use DHCP to automatically obtain the IP address of the appliance, use your computer or a terminal emulator to view your current IP address. See the procedure to “Use Your Computer to Establish Network Settings” on page 14 or steps 1–5 of “Use a Terminal Emulator to Establish Network Settings” on page 15.

NOTE: For detailed instructions on using the Web UI, see the *User Guide* on www.apc.com.

Types of user accounts

The appliance has three types of user accounts:

- Use the **Super User** account to log on to the Web UI after initial configuration. The Super User can create, edit, or delete Administrator account.

The default user name and password for this account are both **superuser**. You are required to change the Super User password the first time you log on to the appliance.

- **Administrators (Admins)** are also used to access the Web UI. Admins are required to change their passwords when they first log on to the appliance. Admins can not create or edit other accounts.
- The **Root** account is used for procedures that require the USB Console port
 - “Use a Terminal Emulator to Establish Network Settings” on page 15
 - “Reset a lost Super User password” on page 16
 - “Reset a lost Root account password” on page 16

NOTE: Except for these procedures, only access the Root account when directed by customer support.

You set the password for the Root account when you first log on to the Root account. You can not change the default user name (**root**).

Reset a lost Super User password

1. Connect to the appliance through SSH or the console port. Log on with the Root account user name (**root**) and password. Within five seconds of logging in, press Shift + X ENTER.
2. Navigate to `/netbotz_app` and enter the following command:

```
./restart.sh stop startApp startClubber resetsupwd
```

The appliance restarts.
3. Log on to the appliance as the Super User (both the user name and password are **superuser**.)
4. Change the default password.

Reset a lost Root account password

1. Connect to the appliance through SSH or the console port.
2. Disconnect and reconnect power to the appliance. Immediately press any key on your computer.
NOTE: If you do not press a key within 5 seconds after you connect power to the appliance, the appliance will restart normally.
3. Enter the following three commands:

```
env set resetpwd true  
env save  
boot
```

Wait for the system to restart.
4. Log in to the Root account. When prompted, reset the Root account password. If you are not prompted to reset the password, wait 10 seconds, then press ENTER to log in again.
5. Disconnect and reconnect power to the appliance. Immediately press any key on your computer.
NOTE: If you do not press a key within 5 seconds after you connect power to the appliance, the appliance will restart normally.
6. Enter the following three commands:

```
env delete resetpwd  
env save  
boot
```

Wait for the system to restart.

NOTE: If you do not complete steps 5 and 6, the root password will be reset every time the appliance restarts.

Reset to defaults

This procedure reboots the appliance and resets all system settings (including passwords and network settings) to factory defaults. If you are unable to access the appliance through its default network settings (DHCP), follow the instructions to “Use a Terminal Emulator to Establish Network Settings” on page 15 after completing this procedure.

1. Log into the Web UI as the Super User.
2. In the browser window, type `<your appliance's IP address>/rest/appliance/resetconfig` in the URL address bar. Press ENTER.

Example: `10.218.117.147/rest/appliance/resetconfig`

The appliance may take up to five minutes to restart completely. Until the restart is complete, the Web UI is not available. The next time you log on to the appliance, you must reset the Super User password.

Discover Downstream Devices

For the appliance to discover a downstream device, you must go to **Settings > System > Device Credentials** and configure the following settings to match the settings on your device.

Setting	Description
Camera (ONVIF)	If you have not already set a password on a Camera Pod 165, you do not have to set the ONVIF credentials for that unit. The appliance will assign it a password.
Username	The user name to access the camera.
Password/Confirm Password	The password to access the camera.
SNMPv1: Read only community name	The name used to access the Read-only community.
SNMPv3	
Username	The identifier of the user profile.
Authentication/Encryption	Select whether to use No security, Authentication only , or both Authentication and Encryption .
Authentication	Verifies that the device communicating through SNMPv3 is the device claims to be, that the message has not been changed during transmission, and that the message was communicated in a timely manner, indicating that it was not delayed and that it was not copied and sent again later at an inappropriate time.
Protocol	SHA1: Slower, but more secure than MD5. MD5: Faster, but less secure than SHA1
Password/Confirm Password	The password or passphrase used for authentication.
Encryption	Encrypts the data sent over SNMPv3.
Protocol	AES-128: More secure than DES. Uses a 128-bit key to encrypt data. DES: Less secure than AES. Uses a 56-bit key.
Password/Confirm Password	The password or passphrase used for authentication.

NOTE: You can use a network switch or hub to connect up to ten downstream devices, including up to four Camera Pod 165 units. The four Camera Pod 165 units can be local (connected to a Private LAN port) or remote (connected through your network).

Configure a Wireless Sensor Network

You can add a total of 47 wireless end devices to your network.

1. Connect the wireless network (See “Connect a wireless sensor network” on page 12).
2. In the Web UI, go to the **Wireless** tab, and click **ADD**.
3. Select one of the following options:

Add Detected Sensors

- a. Select any automatically detected device, or use the **Search** field to find the MAC address for a specific end device. You can enter a name for any selected device in the **Name** field.
- b. Click **ADD** to add all selected devices to the **Wireless** page, or click **CANCEL** to close the window.

Add Sensors Manually

- a. Click **Choose File** to navigate to a CSV file saved on your computer, or type the MAC address of the device in the **MAC Address** field. You can enter a name for any selected device in the **Name** field.
NOTE: The CSV format for each device should be *MAC address, optional name*.
- b. Select **Add another** to add more than one device, or click **Delete** to remove a device. You can enter the name or MAC address of a specific device in the **Search** field to highlight it.
- c. Click **ADD** to add all listed devices to the **Wireless** page, or click **CANCEL** to close the window.

Configure Outlet-controlled Devices

DANGER

SHOCK HAZARD

The switched outlet may have voltage potential when the outlet is set to "off." Always use a properly rated voltage sensing device to confirm there is no voltage in the outlet.

Failure to follow these instructions will result in death or serious injury.

This procedure applies to devices connected to the beacon port, switched outlet, or relay output ports. See the *User Guide* on www.apc.com for details.

1. Connect all sensors and devices.
2. Configure alarms. See the *User Guide* on www.apc.com for details.
3. Set connected devices to activate when specific alarms are generated. See the *User Guide* on www.apc.com for details.

Update the Firmware

1. Download the latest firmware version from the applicable product page on www.apc.com.
2. In the Web UI, select **Settings**, then select **Firmware Update**.
3. Click **Choose File** and navigate to the firmware file on your computer. Do not navigate away from the page while the file is uploading, or the upload will be aborted.
4. Click **INSTALL** to install the firmware, or **START AGAIN** to select a different firmware version.
NOTE: While the firmware is updating, the Web UI is unavailable.

After updating, the appliance automatically restarts.

Specifications

Electrical

Input voltage, nominal	100–240 VAC, 10 A, 50/60 Hz
Maximum total current draw	12 A w/10 A Max. on Aux. Outlet

Physical

Dimensions (H x W x D)	43.5 x 432.0 x 178.0 mm (1.7 x 17.0 x 7.0 in)
Weight	2.4 kg (5.4 lb)

Environmental

Elevation (above MSL)	
Operating	0 to 3000 m (0 to 10,000 ft)
Storage	0 to 15 000 m (0 to 50,000 ft)

Temperature	
Operating	0 to 40°C (32 to 104°F)
Storage	-15 to 65°C (5 to 149°F)

Humidity	
Operating	0 to 95%, non-condensing
Storage	0 to 95%, non-condensing

Terminal Block Output

Voltages	12 VDC and 24 VDC
Current	75 mA total for 12 V and 24 V load

Compliance

EMC	<ul style="list-style-type: none">•EMC directive 2014/30/EU•EN55024:2010, EN55022:2010+AC:2011, Class A•FCC 47 CFR Part 15 Radiated and Conducted Emissions•ICES-003:2012•ASNZS CISPR:22•VCCI V-3:2015
-----	---

Safety	<ul style="list-style-type: none">•cULus / UL-EU / CE - UL/EN/IEC 62368-1•LVD 2014/35/EU
--------	---

Wireless	<ul style="list-style-type: none">•CE - EMC Directive 2004/108/EC/•RED Directive 2014/53/EU•FCC 47 CFR Part 15 Radiated and Conducted
----------	---

Emissions	<ul style="list-style-type: none">• ICES-003:2012•IC: 3351C-NBWC100U•FCC ID: SNSNBWC100U
-----------	--

Sensor Specifications

Beacon

Maximum cable length	100 m (330 ft)
----------------------	----------------

3.65-m (12-ft) Door Switch Sensor for APC Racks (NBES0303), 15.24-m (50-ft) Door Switch Sensor for Rooms or Third Party Racks (NBES0302)

User input response times	200 mS
---------------------------	--------

Maximum cable length	30.48 m (100 ft)
----------------------	------------------

Gap distance	Less than 2.54 cm (1 in.) in air
--------------	----------------------------------

Dry Contact Cable (NBES0304),

User input response times	200 mS
---------------------------	--------

Maximum cable length	30.48 m (100 ft)
----------------------	------------------

Temperature Sensor (AP9335T)

Temperature accuracy	± 1 °C (± 2 °F), from 0 to 40°C (32 to 104°F)
----------------------	--

Sensor operating temperature	-10 to 70°C (14 to 159°F)
------------------------------	---------------------------

Maximum length of cable	15.2 m (50 ft)
-------------------------	----------------

Temperature/Humidity Sensor (AP9335TH)

Temperature accuracy	± 1 °C (± 2 °F), from 32 to 0 to 40°C (104°F)
----------------------	--

Humidity accuracy	± 4 % RH, 20 to 90% RH, at 25°C (77°F) ± 8 % RH, 30 to 80% RH, from 15 to 30°C (59 to 95°F)
-------------------	--

Sensor operating temperature	-10 to 70°C (14 to 159°F)
------------------------------	---------------------------

Two-Year Factory Warranty

This warranty applies only to the products you purchase for your use in accordance with this manual.

Terms of warranty

APC by Schneider Electric warrants its products to be free from defects in materials and workmanship for a period of two years from the date of purchase. APC by Schneider Electric will repair or replace defective products covered by this warranty. This warranty does not apply to equipment that has been damaged by accident, negligence or misapplication or has been altered or modified in any way. Repair or replacement of a defective product or part thereof does not extend the original warranty period. Any parts furnished under this warranty may be new or factory-remanufactured.

Non-transferable warranty

This warranty extends only to the original purchaser who must have properly registered the product. The product may be registered at the APC by Schneider Electric website, www.apc.com.

Exclusions

APC by Schneider Electric shall not be liable under the warranty if its testing and examination disclose that the alleged defect in the product does not exist or was caused by end user's or any third person's misuse, negligence, improper installation or testing. Further, APC by Schneider Electric shall not be liable under the warranty for unauthorized attempts to repair or modify wrong or inadequate electrical voltage or connection, inappropriate on-site operation conditions, corrosive atmosphere, repair, installation, exposure to the elements, Acts of God, fire, theft, or installation contrary to APC by Schneider Electric recommendations or specifications or in any event if the APC by Schneider Electric serial number has been altered, defaced, or removed, or any other cause beyond the range of the intended use.

THERE ARE NO WARRANTIES, EXPRESS OR IMPLIED, BY OPERATION OF LAW OR OTHERWISE, OF PRODUCTS SOLD, SERVICED OR FURNISHED UNDER THIS AGREEMENT OR IN CONNECTION HEREWITH. APC BY SCHNEIDER ELECTRIC DISCLAIMS ALL IMPLIED WARRANTIES OF MERCHANTABILITY, SATISFACTION AND FITNESS FOR A PARTICULAR PURPOSE. APC BY SCHNEIDER ELECTRIC EXPRESS WARRANTIES WILL NOT BE ENLARGED, DIMINISHED, OR AFFECTED BY AND NO OBLIGATION OR LIABILITY WILL ARISE OUT OF, APC BY SCHNEIDER ELECTRIC RENDERING OF TECHNICAL OR OTHER ADVICE OR SERVICE IN CONNECTION WITH THE PRODUCTS. THE FOREGOING WARRANTIES AND REMEDIES ARE EXCLUSIVE AND IN LIEU OF ALL OTHER WARRANTIES AND REMEDIES. THE WARRANTIES SET FORTH ABOVE CONSTITUTE APC BY SCHNEIDER ELECTRIC'S SOLE LIABILITY AND PURCHASER'S EXCLUSIVE REMEDY FOR ANY BREACH OF SUCH WARRANTIES. APC BY SCHNEIDER ELECTRIC WARRANTIES EXTEND ONLY TO PURCHASER AND ARE NOT EXTENDED TO ANY THIRD PARTIES.

IN NO EVENT SHALL APC BY SCHNEIDER ELECTRIC, ITS OFFICERS, DIRECTORS, AFFILIATES OR EMPLOYEES BE LIABLE FOR ANY FORM OF INDIRECT, SPECIAL, CONSEQUENTIAL OR PUNITIVE DAMAGES, ARISING OUT OF THE USE, SERVICE OR INSTALLATION, OF THE PRODUCTS, WHETHER SUCH DAMAGES ARISE IN CONTRACT OR TORT, IRRESPECTIVE OF FAULT, NEGLIGENCE OR STRICT LIABILITY OR WHETHER APC BY SCHNEIDER ELECTRIC HAS BEEN ADVISED IN ADVANCE OF THE POSSIBILITY OF SUCH DAMAGES. SPECIFICALLY, APC BY SCHNEIDER ELECTRIC IS NOT LIABLE FOR ANY COSTS, SUCH AS LOST PROFITS OR REVENUE, LOSS OF EQUIPMENT, LOSS OF USE OF EQUIPMENT, LOSS OF SOFTWARE, LOSS OF DATA, COSTS OF SUBSTITUENTS, CLAIMS BY THIRD PARTIES, OR OTHERWISE.

NO SALESMAN, EMPLOYEE OR AGENT OF APC BY SCHNEIDER ELECTRIC IS AUTHORIZED TO ADD TO OR VARY THE TERMS OF THIS WARRANTY. WARRANTY TERMS MAY BE MODIFIED, IF AT ALL, ONLY IN WRITING SIGNED BY AN APC BY SCHNEIDER ELECTRIC OFFICER AND LEGAL DEPARTMENT.

Warranty claims

Customers with warranty claims issues may access the APC by Schneider Electric customer support network through the Support page of the APC by Schneider Electric website, **www.apc.com/support**. Select your country from the country selection pull-down menu at the top of the Web page to obtain contact information for customer support in your region.

Radio Frequency Interference

Changes or modifications to this unit not expressly approved by the party responsible for compliance could void the user's authority to operate this equipment.

USA—FCC

This equipment has been tested and found to comply with the limits for a Class A digital device, pursuant to part 15 of the FCC Rules. These limits are designed to provide reasonable protection against harmful interference when the equipment is operated in a commercial environment. This equipment generates, uses, and can radiate radio frequency energy and, if not installed and used in accordance with this user manual, may cause harmful interference to radio communications. Operation of this equipment in a residential area is likely to cause harmful interference. The user will bear sole responsibility for correcting such interference.

After an electrostatic discharge (ESD) event, the appliance may require up to 2 minutes to restart services that are necessary for normal operation. During this time, the Web UI of the appliance will be unavailable. If any necessary services or devices external to the appliance, such as a DHCP server, were affected by the ESD event, these devices also need to restart properly.

Canada—ICES

This Class A digital apparatus complies with Canadian ICES-003.

Cet appareil numérique de la classe A est conforme à la norme NMB-003 du Canada.

Japan—VCCI

This is a Class A product based on the standard of the Voluntary Control Council for Interference by Information Technology Equipment (VCCI). If this equipment is used in a domestic environment, radio disturbance may occur, in which case, the user may be required to take corrective actions.

この装置は、情報処理装置等電波障害自主規制協議会（VCCI）の基準に基づくクラス A 情報技術装置です。この装置を家庭環境で使用すると、電波妨害を引き起こすことがあります。この場合には、使用者が適切な対策を講ずるよう要求されることがあります。

Taiwan—BSMI

警告使用者：
這是甲類的資訊產品，在居住的環境中使用時，可能會造成射頻干擾，在這種情況下，使用者會被要求採取某些適當的對策。

Australia and New Zealand

Attention: This is a Class A product. In a domestic environment this product may cause radio interference in which case the user may be required to take adequate measures.

European Union

This product is in conformity with the protection requirements of EU Council Directive 2004/108/EC on the approximation of the laws of the Member States relating to electromagnetic compatibility. APC by Schneider Electric cannot accept responsibility for any failure to satisfy the protection requirements resulting from an unapproved modification of the product.

This product has been tested and found to comply with the limits for Class A Information Technology Equipment according to CISPR 22/European Standard EN 55022. The limits for Class A equipment were derived for commercial and industrial environments to provide a reasonable protection against interference with licensed communication equipment.

Attention: This is a Class A product. In a domestic environment this product may cause radio interference in which case the user may be required to take adequate measures.

Worldwide Customer Support

Customer support for this product is available at www.apc.com.

© 2020 APC by Schneider Electric. APC, the APC logo, NetBotz, NetShelter, and A-Link are trademarks owned by Schneider Electric SE. All other brands may be trademarks of their respective owners.