

TM-H6000V

Technical Reference Guide

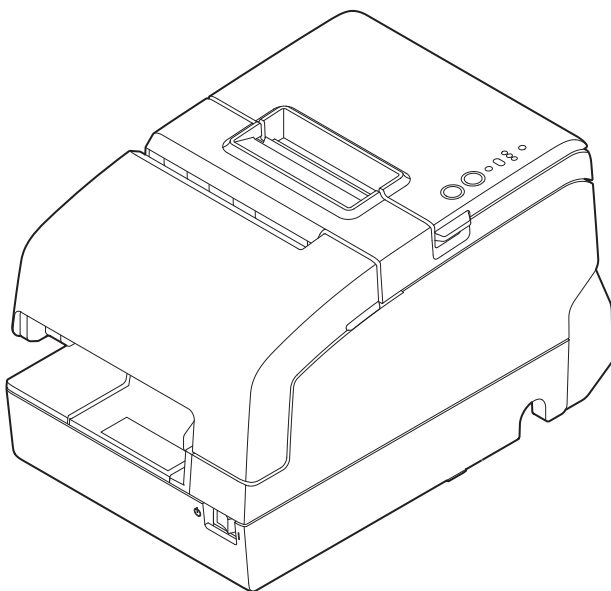

Product Overview

Describes features of the product.

Setup

Describes setup and installation of the product and peripherals.

Advanced Usage

Describes advanced usage methods for the product.

Application Development Information

Describes how to control the printer and necessary information when you develop applications.

Handling

Describes how to handle the product.

Troubleshooting

Describes actions to take when a trouble occurs.

Replacement of the TM-H6000IV

Describes precautions for replacement.

Appendix

Describes general specifications and character code tables.

Cautions

- No part of this document may be reproduced, stored in a retrieval system, or transmitted in any form or by any means, electronic, mechanical, photocopying, recording, or otherwise, without the prior written permission of Seiko Epson Corporation.
- The contents of this document are subject to change without notice. Please contact us for the latest information.
- While every precaution has been taken in the preparation of this document, Seiko Epson Corporation assumes no responsibility for errors or omissions.
- Neither is any liability assumed for damages resulting from the use of the information contained herein.
- Neither Seiko Epson Corporation nor its affiliates shall be liable to the purchaser of this product or third parties for damages, losses, costs, or expenses incurred by the purchaser or third parties as a result of: accident, misuse, or abuse of this product or unauthorized modifications, repairs, or alterations to this product, or (excluding the U.S.) failure to strictly comply with Seiko Epson Corporation's operating and maintenance instructions.
- Seiko Epson Corporation shall not be liable against any damages or problems arising from the use of any options or any consumable products other than those designated as Original Epson Products or Epson Approved Products by Seiko Epson Corporation.

Trademarks

EPSON is a registered trademark of Seiko Epson Corporation.

Exceed Your Vision and ESC/POS are registered trademarks or trademarks of Seiko Epson Corporation.

Microsoft, Windows, and Windows Vista are registered trademarks of Microsoft Corporation in the United States and/or other countries.

Wi-Fi[®], WPA[™], and WPA2[™] are either registered trademarks or trademarks of Wi-Fi Alliance[®].

The Bluetooth[®] word mark and logos are registered trademarks owned by Bluetooth SIG, Inc. and any use of such marks by Seiko Epson Corporation is under license.

IOS is a trademark or registered trademark of Cisco in the U.S. and other countries and is used under license.

AirPlay, iPad, iPhone, iPod, iPod classic, iPod nano, iPod touch, and Retina are trademarks of Apple Inc., registered in the U.S. and other countries. iPad Air, iPad mini, and Lightning are trademarks of Apple Inc.

iBeacon is a trademark of Apple Inc.

Android and Google Play are trademarks of Google, Inc.

All other trademarks are the property of their respective owners and used for identification purpose only.

ESC/POS[®] Command System

Epson ESC/POS is a proprietary POS printer command system that includes patented or patent-pending commands. ESC/POS is compatible with most Epson POS printers and displays.



ESC/POS is designed to reduce the processing load on the host computer in POS environments. It comprises a set of highly functional and efficient commands and also offers the flexibility to easily make future upgrades.

©Seiko Epson Corporation 2018. All rights reserved.

For Safety

Key to Symbols

The symbols in this manual are identified by their level of importance, as defined below. Read the following carefully before handling the product.

 WARNING	You must follow warnings carefully to avoid serious bodily injury.
 CAUTION	Provides information that must be observed to prevent damage to the equipment or loss of data. <ul style="list-style-type: none">• Possibility of sustaining physical injuries.• Possibility of causing physical damage.• Possibility of causing information loss.
CAUTION	Provides information that must be observed to avoid damage to your equipment or a malfunction.
NOTE	Provides important information and useful tips.

Warnings

 WARNING	<ul style="list-style-type: none">• Shut down your equipment immediately if it produces smoke, a strange odor, or unusual noise. Continued use may lead to fire. Immediately unplug the equipment and contact qualified service personnel for advice.• Never attempt to repair this product yourself. Improper repair work can be dangerous.• Never disassemble or modify this product. Tampering with this product may result in injury or fire.• Do not use this product with any voltage other than the specified one. Doing so may lead to fire or electric shock.• For the power cable, use either the included one or a designated one that meets the relevant safety standards of the area where you plan to use it.• Do not allow foreign matter to fall into the equipment. Penetration by foreign objects may lead to fire.• If water or other liquid spills into this equipment, unplug the AC cable immediately, and contact qualified service personnel for advice. Continued usage may lead to fire.• Do not use aerosol sprayers containing flammable gas inside or around this product. Doing so may cause fire.
---	---

Cautions



- Do not connect cables in ways other than those mentioned in this manual. Different connections may cause equipment damage and burning.
- Be sure to set this equipment on a firm, stable, horizontal surface. Product may break or cause injury if it falls.
- Do not use in locations subject to high humidity or dust levels. Excessive humidity and dust may cause equipment damage or fire.
- Do not place heavy objects on top of this product. Never stand or lean on this product. Equipment may fall or collapse, causing breakage and possible injury.
- Take care not to injure your fingers on the manual cutter
 - When you remove printed paper
 - When you perform other operations, such as loading/replacing roll paper
- To ensure safety, unplug this product before leaving it unused for an extended period.
- Do not connect a telephone line to the drawer kick connector or the display module connector; otherwise the printer and the telephone line may be damaged.
- Do not put your hand inside this product or touch the white flat cable during printing.
- Make sure cords and foreign objects are not caught in the printer.
- Do not open the covers during printing or autocutting.
- To prevent a paper jam, do not prevent paper from being ejected from the paper exit, and do not pull the paper being ejected.

Caution Labels

The caution labels on the product indicate the following precautions.



Do not touch the thermal head because it can be very hot after printing.



Do not touch the cables in the product. Doing so can cause product malfunctions.

Restriction of Use

When this product is used for applications requiring high reliability/safety, such as transportation devices related to aviation, rail, marine, automotive, etc.; disaster prevention devices; various safety devices, etc.; or functional/precision devices, etc., you should use this product only after giving consideration to including fail-safes and redundancies into your design to maintain safety and total system reliability. Because this product was not intended for use in applications requiring extremely high reliability/safety, such as aerospace equipment, main communication equipment, nuclear power control equipment, or medical equipment related to direct medical care, etc., please make your own judgment on this product's suitability after a full evaluation.

Note about interference

- This product generates, uses, and can radiate radio frequency energy and, if not installed and used in accordance with the instruction manual, may cause harmful interference to radio communications.
- If this equipment does cause harmful interference to radio or television reception, which can be determined by turning the equipment off and on, the user is encouraged to try to correct the interference by one or more of the following measures:
 - Reorient or relocate the receiving antenna for the radio/TV.
 - Increase the separation between the equipment and the radio/TV.
 - Connect the equipment into an outlet on a circuit different from that to which the receiver is connected.
 - Consult your dealer or an experienced radio/TV technician for help.
- Never disassemble or modify this product.
- Seiko Epson Corporation shall not be liable for interference to radio/TV resulting from changes or modifications to this product not expressly approved by Seiko Epson Corporation.

Open Source Software License

This product uses open source software in addition to Epson proprietary software.

For information of the open source software used in this product, see the following URL.

<https://xxx.xxx.xxx.xxx/licenses.html>

For “xxx.xxx.xxx.xxx” in the above URL, input your printer’s IP address.

About this Manual

Aim of the Manual

This manual provides developers/engineers with all the necessary information for design, development and installation of a POS system, and also design and development of a printer application.

Manual Content

The manual is made up of the following sections:

Chapter 1	Product Overview
Chapter 2	Setup
Chapter 3	Advanced Usage
Chapter 4	Application Development Information
Chapter 5	Handling
Chapter 6	Troubleshooting
Chapter 7	Replacement of the TM-H6000IV
Appendix	Product Specifications Character Code Tables

Contents

■ For Safety	3
Key to Symbols.....	3
Warnings	3
Cautions.....	4
■ Caution Labels	4
■ Restriction of Use	5
■ Note about interference	5
■ Open Source Software License.....	5
■ About this Manual	6
Aim of the Manual	6
Manual Content.....	6
■ Contents.....	7

Product Overview 13

■ Features	13
■ Product Configurations	15
Models.....	15
Case color.....	15
Accessories	15
■ Part Names and Functions	16
Control Panel	17
Connectors	18
Online and Offline.....	19
LED on/flashing patterns.....	20
■ NV Memory	22
NV Graphics Memory	22
User NV Memory	22
Memory Switches.....	22
R/E (Receipt Enhancement).....	22
Maintenance Counter.....	23
■ Simple Setup for Wireless LAN	24
■ Useful Functions for Smart Devices.....	25
Setup Wizard	25
Change Printer Settings.....	25
Demonstration	25
■ Printing Using Multiple Interfaces	26

Setup	27
■ Flow of Setup	27
■ Removing the Protective Materials and Tape	29
■ Connecting the AC adapter	30
Connecting the AC adapter	30
■ Connecting the Printer to the Host	32
USB Interface	32
Ethernet Interface	32
Wireless LAN Interface	33
Serial Interface	36
USB Plus Power Interface	36
■ Connecting the Cash Drawer	37
Required specifications of cash drawer	37
Connecting the drawer kick cable	38
■ Installing the Customer Display	39
■ Attaching the Connector Cover	40
■ Installing and Replacing the Ribbon Cartridge	41
■ Installing and Replacing the Ribbon Cartridge for Endorsement Printing	43
■ Installing the Roll Paper	46
■ Test Printing	48
Test Printing on Roll Paper	48
Test Printing on Slip Paper	48
■ Attaching the Power Switch Cover	49
■ Applying the LED Information Label	50
■ RTC Settings	52
■ Adjusting the Paper Roll Near-End Sensor	53
■ Changing the Paper Width	54

Advanced Usage55

■ Setting the DIP Switches.....	55
Setting Procedure	55
When a Serial Interface is Connected	56
When Another Interface is Connected.....	58
Selecting the Print Density (DIP Switches 2-3/2-4)	59
Selecting the BUSY Status.....	59
■ Software Settings.....	60
Functions.....	62
Setting and reference items shared by Ethernet/Wi-Fi	67
Setting and reference items for Ethernet	68
Setting and reference items for Wi-Fi.....	69
■ Setting/Checking Modes	70
Self-test Mode	72
NV Graphics Information Print Mode.....	73
Receipt Enhancement Information Print Mode	74
Software Setting Mode	75
Restore Default Values Mode.....	77
Interface Setup Mode.....	78
TM-Intelligent Settings Information Print Mode	79
Peripheral Device Information Print Mode	79
Hexadecimal Dumping Mode	80
■ Printing a Status Sheet.....	81
■ Resetting the Interface Settings	84
■ TM-Intelligent Function	85
Server direct print	85

Application Development Information.....86

■ Controlling the Printer	86
ePOS-Print XML.....	86
ePOS-Device XML.....	86
ESC/POS.....	86

■ Controlling the Cash Drawer.....	87
■ Software.....	88
Development Kits	88
Drivers	89
Utilities	89
Others.....	90
Download	90

Handling 91

■ Installing and Replacing Roll Paper.....	91
■ Installing Slip Paper	93
■ Inserting Validation Paper.....	94
■ Cleaning the Product.....	95
Cleaning the Printer Case.....	95
Cleaning the Thermal Head and the Platen Roller	95
Cleaning the MICR Head.....	96
■ Preparing for Transport.....	97

Troubleshooting..... 98

■ LED on/flashing patterns.....	99
LED on/flashing patterns.....	99
Printer operating status	100
Errors that recover automatically	101
Recoverable errors	101
Unrecoverable errors	102
■ Print Quality Problem.....	103
Print Quality Problem (Receipt printer).....	103
Print Quality Problem (Slip/ Validation/ Endorsement printer).....	103
■ Setting slip paper does not start printing.....	105
Slip LED is flashing continuously.....	105
Slip LED is flashing 3 times	105
Slip LED is off.....	105
Slip LED does not change from flashing to lit up	105
■ Even when slip paper is set, paper is fed and an error occurs.....	106
■ Slip LED does not turn off even though slip paper is removed.....	106
■ MICR cannot be read	106
■ The customer display does not appear.....	107
Does not appear on the customer display.....	107
Text is garbled	107

■ The cash drawer does not open	107
■ Printing from the computer is disabled/Printing was suddenly.....	108
USB Connections.....	108
LAN Connections.....	108
Wi-Fi Connections.....	108
■ Power does not turn on	109
■ Auto cutter error	110
■ Paper jam.....	113
Roll paper is jammed	113
Slip paper is jammed	114
■ Roll paper cover will not open.....	117
Printing stop by cover open.....	118
■ Printing from the computer is disabled/Printing was suddenly.....	119
Printer is offline	119
Reconnect the printer and the computer	119
LAN setting.....	119
Check installation of printer driver	119
■ Power does not turn on	120

Replacement of the TM-H6000IV 121

■ Compatibility	122
Printing	122
Print Density.....	122
Printable Area	122
Cutting Method	122
Receive Buffer.....	122
Memory Capacity.....	123
Electrical Characteristics	123
DIP Switches.....	123
Printer Status	123
Logo Registration.....	123
Driver Compatibility.....	123
USB Low Power Consumption Mode	123
Maintenance Counter.....	123
Overall Dimensions	124
■ Additional Functions and Functional Improvements	125
Print Speed	125
Interface.....	125
SimpleAP Function	125
NFC.....	125
Epson TM Utility for iOS/Android	125
Software Settings.....	126
TM-Intelligent function.....	126

Appendix.....	127
■ Product Specifications	127
Printing Specifications.....	129
Character Specifications	131
Paper Specifications	132
Printable Area	135
Printing and Cutting Positions	137
Ribbon Cassette.....	137
Notes on using the endorsement printer.....	138
MICR Reader (Factory-Installed Option)	138
Barcode/ Two-dimensional symbol/composite symbol	141
Electrical Characteristics	142
Reliability.....	143
Environmental Conditions.....	144
External Dimensions and Mass	145
■ Bluetooth Low Energy Technology Advertising.....	146
Introduction	146
Dongle specifications	146
Procedure.....	146
Changing the Bluetooth Low Energy Technology Advertising Packet.....	147
■ Character Code Tables.....	158

Product Overview

This chapter describes features and specifications of the product.

Features

Slip printing

- High throughput using bidirectional minimum distance printing.
- MICR reading function (option)
- Eight-line validation printing function (option)
- Check endorsement printing function (option)
- Check MICR reading, endorsement printing, and slip printing are performed continuously in that order.

Receipt printing

- High speed printing (350 mm/s maximum).
- Multi-tone graphic printing.
- Bar code and two-dimensional symbol printing.
- Shifting from 80 mm width paper printing to 58 mm width paper printing is available.
- An autocutter is equipped.
- Paper saving function.

Handling

- Easy drop-in paper loading

Software

- TM-Intelligent function is equipped.
 - Supports Server Direct Print that sends a request for print data from the product to the Web server at regular intervals.
- ESC/POS Command System.
- OPOS ADK, OPOS ADK for .NET, JavaPOS ADK, and Windows printer drivers.
- Printing from a tablet (Epson ePOS SDK)
- Bar code and two-dimensional symbol printing.

Environment

- Compliant with International ENERGY STAR Program.

Functions

- Various interface models are available.
- Optional Wireless LAN cable set and customer display are available.
- NFC tag built into the printer unit for printing to a touched printer.
- Supports printing using multiple interfaces.
- Enables HTTPS communication.
- A maintenance counter function is equipped.

Others

- Small footprint and simple design.
- Direct connection of Epson customer display series (DM-D) is possible.

Product Configurations

Models

Model name	MICR	Endorsement printer	Validation
Basic model	-	-	-
MICR model	✓	-	-
Endorsement/MICR model	✓	✓	-
Validation model	-	-	✓
Validation/MICR model	✓	-	✓

Case color

- Black (EBCK)
- White (ENN8.5)

Accessories

Included

- AC adapter *
- AC cable *
- Roll paper
- Power switch cover
- Connector cover
- Manuals
- LED information label *
- Ink ribbon cartridge ERC-32(B)
- Ink ribbon cartridge ERC-43(B) *

* May not be included depending on the model.

Options

- PG-58II: 58 mm width paper guide.
- TA-6000II: Printer attachment.
- OT-FT6000: Front tray for aiding insertion of slip paper.
- OT-DC6000: Cover for protecting the wireless LAN unit.
- OT-WL02, OT-WL05: Wireless LAN cable set.
- DM-D110, DM-D210: Customer display.
- DP-502: Dedicated stand for customer display.



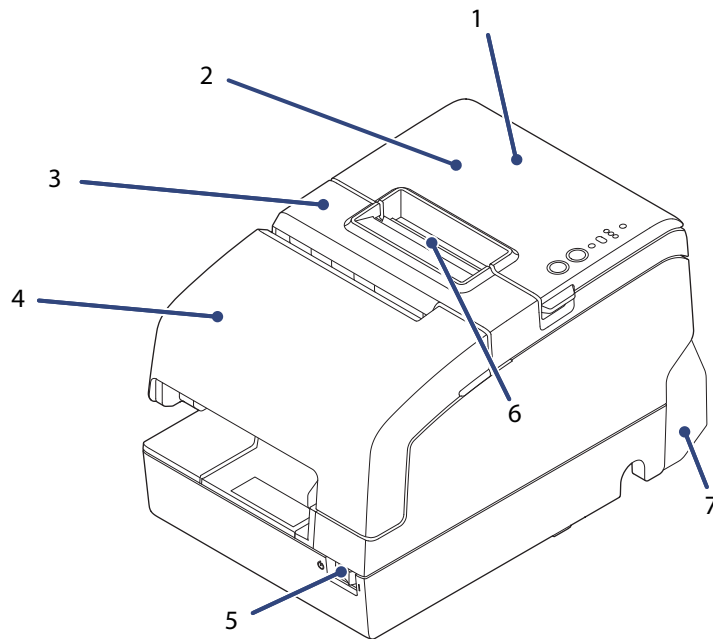



Part Names and Functions

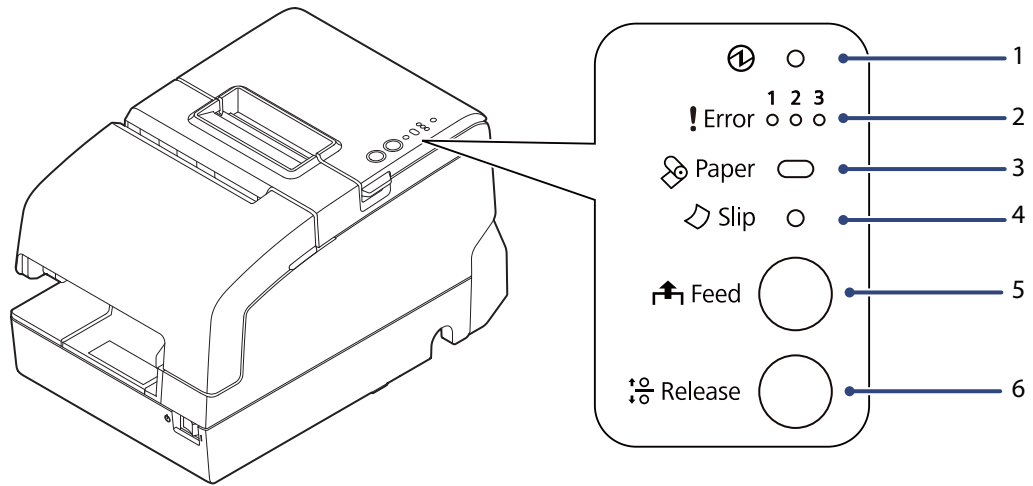

1	NFC Tag	A mark is printed here to indicate the position of the NFC tag. To establish communication with an NFC device, bring the device close to this mark.
2	Roll paper cover	Open this cover to install/replace the roll paper.
3	Receipt unit	Open this cover to install/replace the ribbon cartridge for endorsement printing.
4	Front cover	Open this cover to install/replace the ribbon cartridge for slip/validation printing.
5	Power switch	Use this switch to turn on or off the printer.
6	Manual cutter	Use this cutter when you cut the roll paper manually.
7	Connector cover	Use this cover to hide and protect rear connectors and cables.

Control Panel



1	 (Power) LED	On when the printer is on.
2	 Error LED	The 3 LEDs indicate an error status. (See " LED on/flashing patterns " on page 20.)
3	 Paper LED	Flashes when waiting for test printing on the roll paper. Flashes to instruct you to press the Feed button and when there is a paper near-end. On when there is no paper.
4	 Slip LED	On when the printer is in slip paper mode. Off when the printer is in roll paper mode. Flashes when the printer is waiting for slip paper to be inserted/removed.
5	 Feed button	This button feeds paper.
6	 Release button	This button releases the retained paper.

Connectors

All connectors are located on the lower rear of the printer.

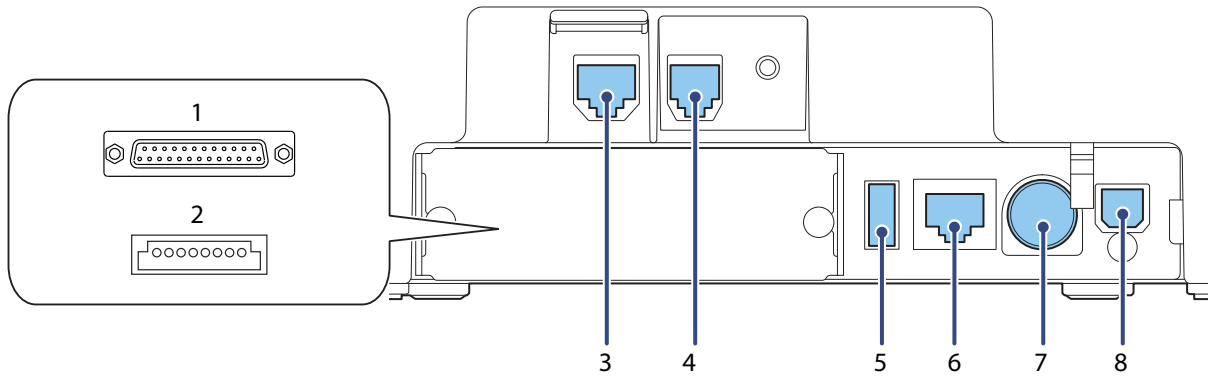

1	Serial Interface connector	For connecting a serial cable for connecting to a computer.
2	USB Plus Power connector	For connecting a USB Plus Power cable for connecting to a computer.
3	DM-D connector	For connecting the customer display.
4	Drawer kick connector	For connecting a modular cable for the cash drawer.
5	USB connector	For connecting the Epson certified unit.
6	Ethernet connector	For connecting a LAN cable.
7	Power supply connector	For connecting the AC adapter.
8	USB connector (type-B)	For connecting a USB cable for connecting to a computer.

Online and Offline

Online

When the product is ready for normal printing, it is "online".

Offline

The printer automatically goes offline under the following conditions:

- While the printer power is turning on/off
- While a self-test is running
- While the roll paper cover, the front cover or the receipt unit is open
- While roll paper is fed using the Feed button
- When the printer stops printing due to a paper-end
(if an empty paper supply is detected by the roll paper end sensor or if the driver has been set to stop printing when a roll paper near end is detected)
- During a macro execution standby state
- When an error has occurred

LED on/flashing patterns

The status of the printer is indicated by lit and flashing LEDs.

CAUTION

- You cannot print when an error has occurred.
- Or, you can scan the QR code using your smart device to check detailed information about the error and the solution.





































































- Refer to troubleshooting for the patterns displayed when an error occurs. (See "LED on/flashing patterns" on page 99.)

1

Mark	Status of LED
	On
	Off
	Flashing
	Flashing
	Flashing
	Flashing
-	LED either on, off or flashing

Power LED	Error LED			Paper LED	Slip LED	Printer Status
	1	2	3			
						Online (Normal status)
						Roll paper near end
				-	-	Roll paper cover or front cover open when not printing

Power LED 	Error LED 			Paper LED 	Slip LED 	Printer Status
	1	2	3			
					-	No paper
						Slip paper selection/printing conditions
						Slip paper insertion standby
					 (2)	Slip paper removal standby
					 (2)	Check insertion standby (Only MICR model)
				-	-	TM-Intelligent function warning
	-	-	-		-	<ul style="list-style-type: none"> Continued self-test standby Macro execution standby Standby for closing roll paper cover when printing status sheet
						Updating firmware
						Powering off
						Power OFF standby
				-	-	Errors that recover automatically
						The power is off or is not being supplied

NV Memory

The printer's NV memory (Non-Volatile Memory) stores data even after the printer power is turned off. NV memory contains the following memory areas for the user:

- NV graphics memory
- User NV memory
- Memory switches
- R/E (Receipt Enhancement)
- Maintenance counter



NV memory can be rewritten about 100,000 times. As a guide, NV memory rewriting should be 10 times or less a day when you program applications.

NV Graphics Memory

Graphics, such as shop logos to be printed on receipts, can be stored. Even with a serial interface model whose communication speed is low, high speed graphics printing is possible.

Use the Setup Utilities to register graphics.

You can confirm the registered graphics in the NV graphics information print mode.



- For detailed information about the Epson TM-H6000V Utility for Windows, see the TM-H6000V Utility User's Manual.
- For information about how to use the NV graphics information print mode, see "[NV Graphics Information Print Mode](#)" on page 73.

User NV Memory

You can store and read text data for multiple purposes, such as for storing a note including customizing or maintenance information of the printer.

Memory Switches

With the memory switches, which are software switches for the printer, you can configure various settings of the printer. For information about the memory switch, see "[Software Settings](#)" on page 60.

R/E (Receipt Enhancement)

Graphics, such as shop logos to be printed on top or bottom of receipts can be registered.

Use the Setup Utilities to register graphics.

Maintenance Counter

With this function, printer information, such as the number of lines printed, the number of autocuts, and printer operation time after the printer starts working, is automatically stored in NV memory.

NOTE

You can also check the head running length and number of times of autocutting with the self-test (see ["Self-test Mode" on page 72](#)).

Simple Setup for Wireless LAN

This printer comes with a mode (SimpleAP) that allows printers to connect with a smart device or a computer without requiring a wireless access point. This allows you to easily setup a wireless LAN for the printer by using a printer settings tool (Epson TM Utility for iOS/Android or EpsonNet Config) even without a network environment such as access points.

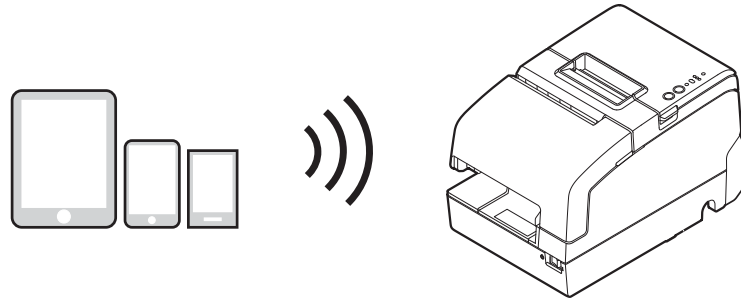

SimpleAP mode is enabled by default when shipping from the factory. When SimpleAP mode is enabled and the printer is turned on, the following information is printed automatically.

```

SimpleAP Start
SSID           : EPSON_Printer
Encryption Type : WPA-2-PSK
Passphrase     : 12345678

IP Address      : 192.168.192.168
MAC Address     : xx-xx-xx-xx-xx-xx
  
```

Although operations are performed in SimpleAP mode during the initial startup, operations switch to standard mode (infrastructure mode) when changing settings in Epson TM-H6000V Utility for Windows. After switching, operations continue in standard mode. If you want to make settings in SimpleAP mode again, initialize the communication settings (see "[Resetting the Interface Settings](#)" on page 84).

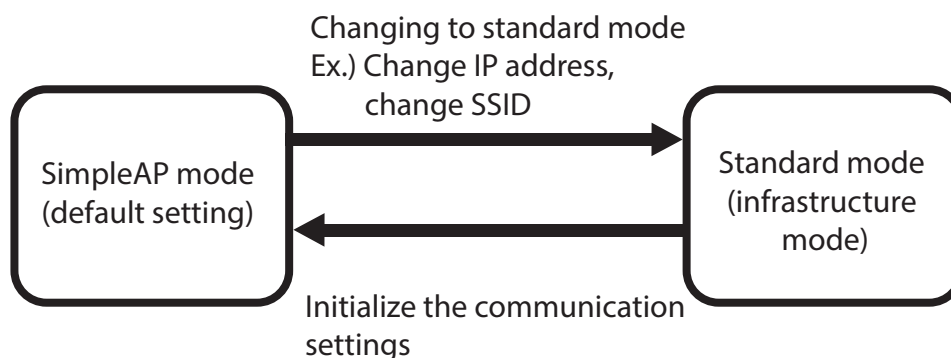

* You can also set as standard mode (Ad-Hoc mode)

Useful Functions for Smart Devices

The Epson TM Utility for iOS/Android app provides the following useful functions for iOS and Android smart devices.

- View Printer Status
- Change Printer Settings
- Check Printer Operations
- Demonstration
- Wi-Fi® Setup Wizard
- Update the Firmware

NOTE

You can download the Epson TM Utility for iOS/Android from the App Store or Google Play™.

Setup Wizard

The wizard provided allows you to easily connect to smart devices.

For how to set the wireless LAN interface, see ["Setting up from a Smart Device" on page 36](#).

Change Printer Settings

You can change the software settings of the connected printer.

For an outline of the function, see ["Software Settings" on page 60](#).

Demonstration

Touch your device to the NFC tag built-in to the printer, or capture the QR code with the camera on your smart device to select the printer and begin printing. You can try a demo of this function in Epson TM Utility for iOS/Android.

Specify the printer selection method from "Demonstration" in the menu, then follow the on-screen instructions.

NOTE

Use Epson ePOS SDK to build this function into your application. This function is created by combining NFC touch and QR code capturing operations, the target printer specifications using Printer Easy Select API, and the print processing.

See the "Epson ePOS SDK for Android/iOS User's Manual" and the Epson ePOS SDK sample program for more details. The sample program also contains a sample implementation method for reading an NFC tag and capturing a QR code.

Printing Using Multiple Interfaces

In printers with multiple interfaces, you can use all interfaces without any limitations on which interface is to be used. You can use this function to temporarily connect a smart device to a nearby printer and print.

The printer provides each interface with an independent receive buffer and switches the active interface depending on the priority, while handling data in each receive buffer.

You can set one interface for the main connection. Data received from the main connection interface is handled with the highest priority.

By default, the interface that receives the first data transfer is set as the main connection interface; however, you can select the main connection interface in advance.

In the status where all receive buffers are empty for more than the set time (1 second by default), interface switching is enabled. The interface that receives the data in this status becomes active.

CAUTION

You cannot use wired and wireless LANs at the same time. When a LAN cable is connected, wireless LAN is disabled.

NOTE

You can select the main connection interface and set the time to enable interface switching from the software settings. For details on software settings, see "[Software Settings](#)" on page 60. When the MICR/Slip/Endorse station is selected, interrupts from other interfaces cannot be performed.

Setup

This chapter describes setup and installation of the product and peripherals.

Flow of Setup

This chapter consists of the following sections along with the setup flow of the product and peripherals.

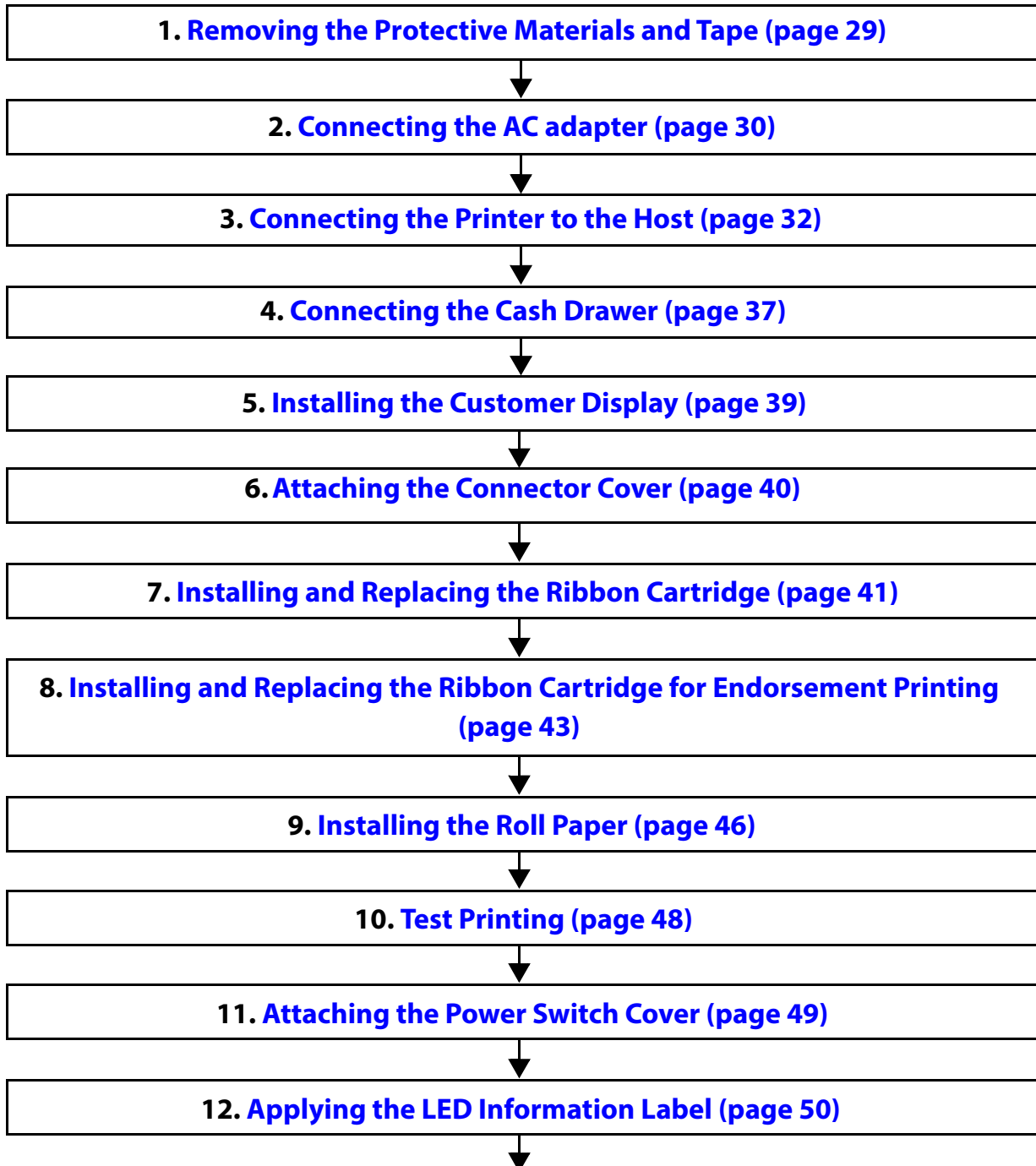

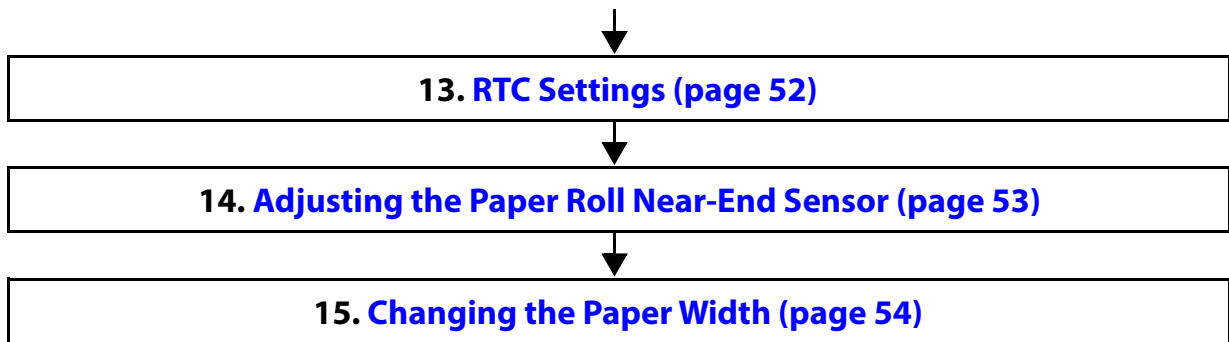

Removing the Protective Materials and Tape

Protective materials and tape are applied for protection against impacts during transportation. Remove all of them, from A to L.

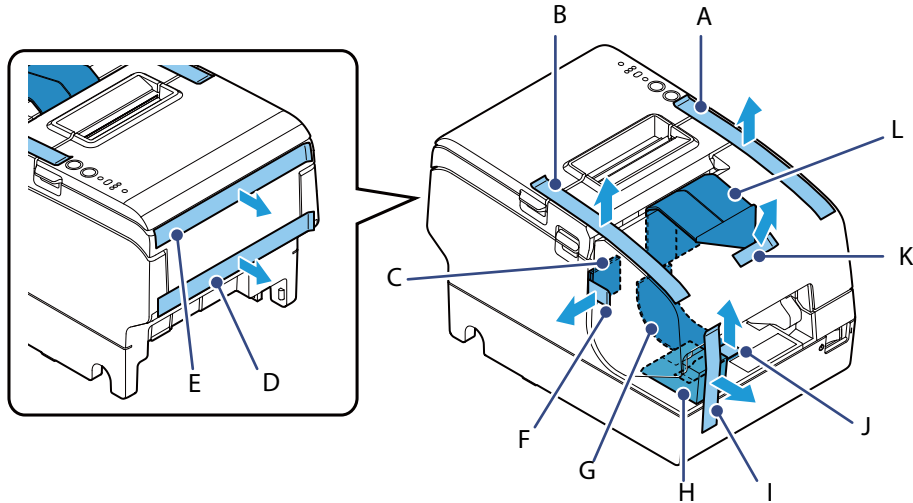

To remove protective material L, you must open the receipt unit.

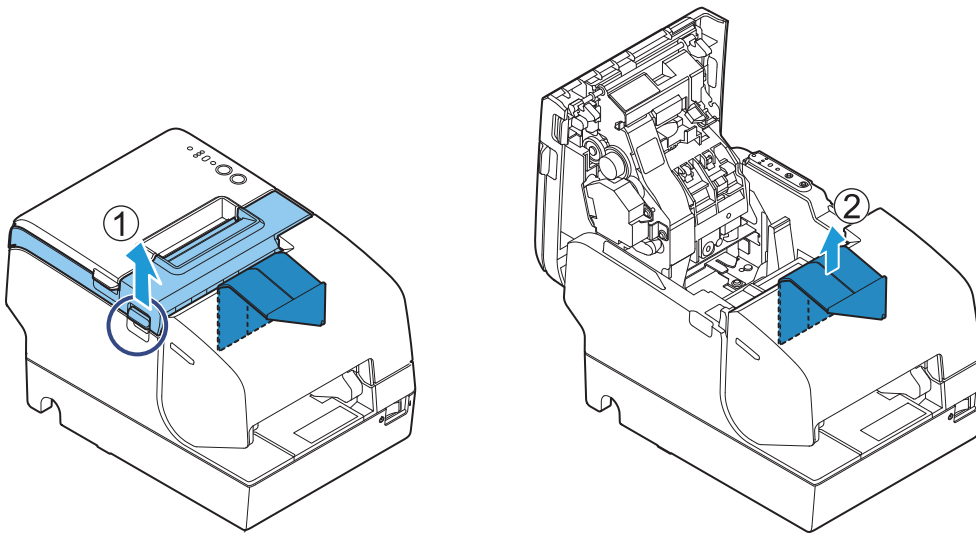

Connecting the AC adapter

Use the Epson PS-180 or an equivalent product as the AC adapter.



- Never insert the AC cable plug into a socket that does not meet the input voltage of the AC adapter. Doing so may result in damage to the printer.
- Should a fault ever occur, immediately turn off the power to the printer and unplug the AC cable from the socket.

Connecting the AC adapter

- 1 Make sure the printer is turned off.
- 2 Connect the AC cable to the AC port of the AC adapter.

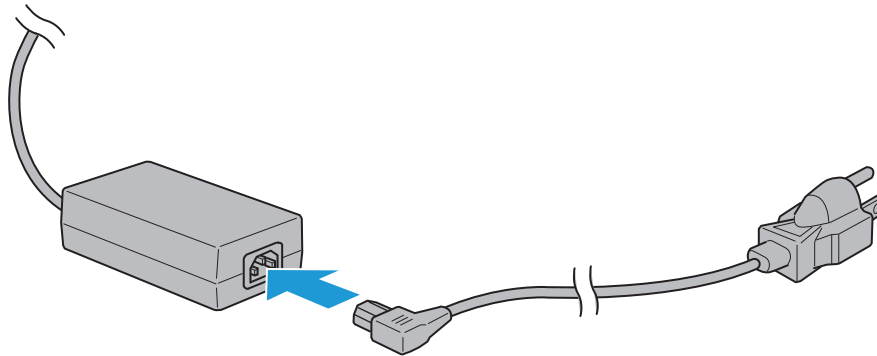

- 3 Connect the DC cable to the printer.

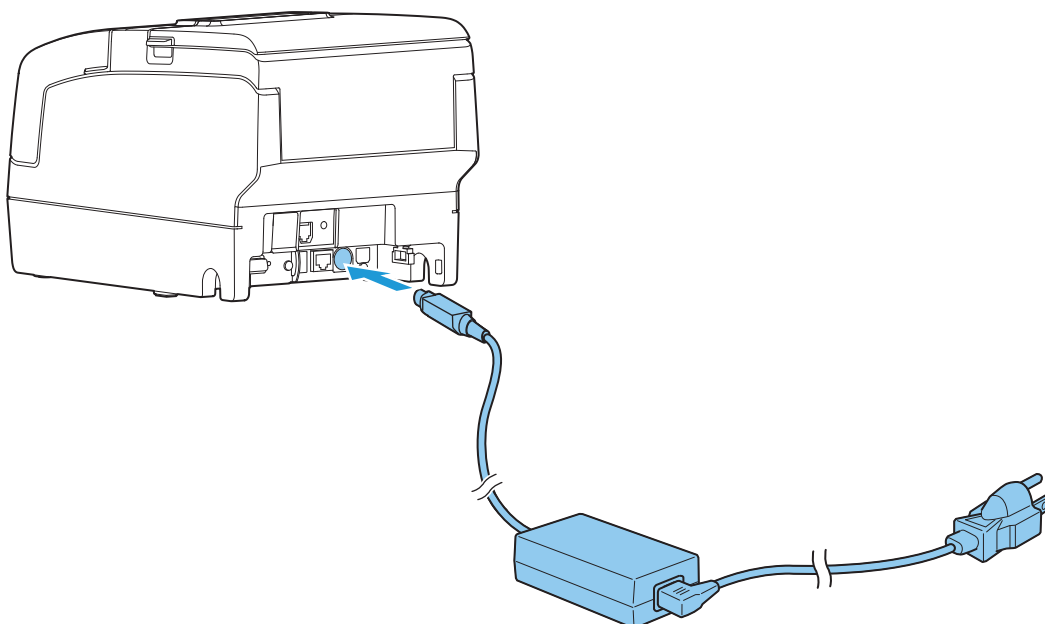

- 4 Insert the AC cable plug into a power outlet.

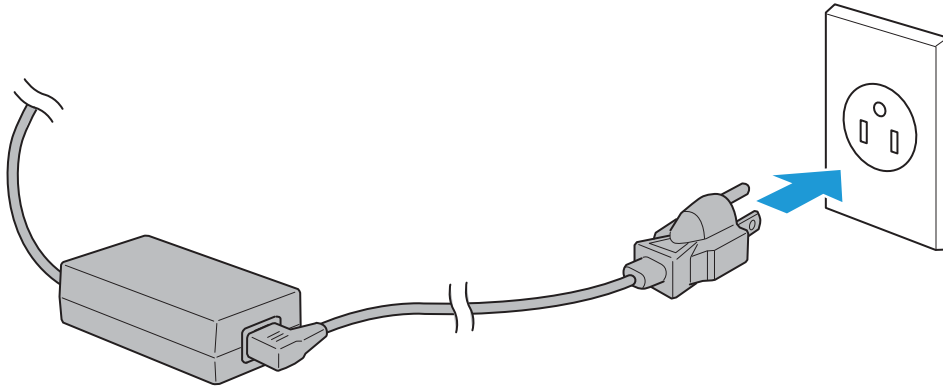

- 5 Set the AC adapter so that its label side is facing down.

Connecting the Printer to the Host

CAUTION

- Be sure to install the driver before connecting the printer to the host computer.
- The printer uses modular connectors specifically designed for the cash drawer. Do not connect these connectors to an ordinary telephone line.

USB Interface

When using the USB interface, fix the USB cable with the locking wire saddle to prevent the USB cable from coming off.

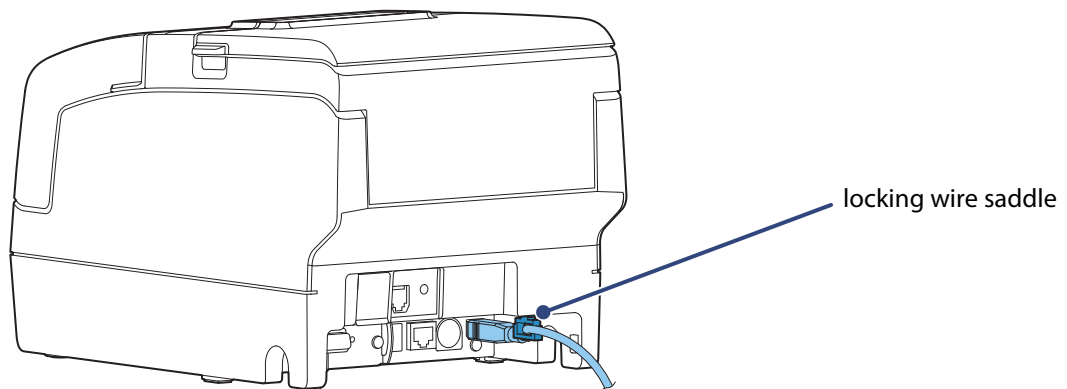

CAUTION

Do not place any weight or stress on the cable when using. Doing so could damage the cable and connectors.

Ethernet Interface

Use ethernet cable to connect the printer to network via a hub.

Use Epson TM-H6000V Utility for Windows or EpsonNet Config to set network.

For details on Epson TM-H6000V Utility for Windows, refer to TM-H6000V Utility User's Manual.

CAUTION

- When LAN cables are installed outdoors, make sure they are connected through devices that have surge protection. Otherwise, the devices can be damaged by lightning.
- Never attempt to connect the drawer kick cable or a standard telephone line cable to the LAN connector.
- Do not insert the Ethernet cable into the DM-D connector.

NOTE

As same with Conventional models, you can use EpsonNet Config (Web version) in the same way.
User name/password: Epson

Wireless LAN Interface

You can connect using a wired cable (LAN/USB), or connect using SimpleAP mode, and setup a wireless LAN using a TM-H6000V Utility. When setting up multiple printers, you can connect using a wired cable (LAN/USB) and setup a wireless LAN using the Epson Deployment Tool.

Using Epson TM Utility for iOS/Android, you can easily connect the printer to the network from an iOS or Android devices.

CAUTION

- When using wireless LAN, make sure you disconnect the LAN cable. If a LAN cable is connected, wireless LAN is disabled.
- When you set up the access point at the same time, set the access point in advance and check that it operates correctly.
- Examine the radio wave situation in the surrounding area before use.
- Avoid using the same channel that is used in the neighboring shops where Wireless LAN is used.
- Wireless LANs with a frequency band of 2.4 GHz interfere with *Bluetooth*® communication. When using *Bluetooth* and Wi-Fi at the same time, we recommend using 5 GHz.
- When using the printer in environments where kitchen microwaves and other devices that may interfere radio waves are installed, observe the following points.
- Keep the printer away from the devices, such as kitchen microwaves, that may cause radio wave interference.
- Use channels that are away from the frequency bands that may cause radio wave interference.
- Place shields between the printer and the devices that may cause radio wave interference.
- Select either 2.4 GHz or 5 GHz, whichever is free from radio wave interference.
- In auto channel setting for the access point, do not select a channel in which the devices may cause radio wave interference.
- In the infrastructure mode, W53 and W56 channels are not available to connect to a stealth SSID access point.

NOTE

For SimpleAP mode, see "[Simple Setup for Wireless LAN](#)" on page 24.

Connecting the Optional Wireless LAN Unit

The optional Wireless LAN cable set (OT-WL02/OT-WL05) enables you to use the product with a Wi-Fi connection.

For more information, refer to Technical Reference Guide of the Wireless LAN cable set.

CAUTION

- Be sure to turn off the printer when connecting the Wireless LAN unit.
- Depending on the installation conditions of the printer and the routing for cables connected to it, the status of the radio waves for the Wireless LAN unit may decline. If this does happen, use an extension cable.

NOTE

- This option may be included with this product, depends on the models.
- The shape of the Wireless LAN unit varies depending on the model.

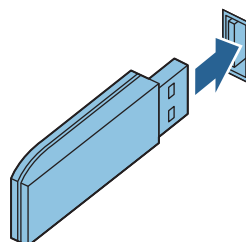

Setting up Using a SimpleAP Connection from a Windows Computer

Necessary Items

Prepare the following items.

- Computer for setting: Windows 10/8/7/Vista
Computer equipped with a wireless LAN function
- Utility for setting: Epson TM-H6000V Utility for Windows

Follow the steps below to connect the printer.

1 Turn on the printer.

After starting the printer, check that the "SimpleAP Start" is printed. If it is not printed, you need to enable SimpleAP mode in interface settings mode.

2 Activate Windows Wireless Network Connection and select [EPSON_Printer] as the connection device on the screen that appears.

If the window to enter a pass phrase appears, enter "12345678".

Default settings on printer are the following values.

Network mode	SimpleAP mode
SSID	EPSON_Printer
Pass phrase	12345678
IP Address	192.168.192.168

3 When connecting to the printer is complete, setup the Wireless LAN using the network setup tool, Epson TM-H6000V Utility for Windows.

For details about Epson TM-H6000V Utility for Windows, see TM-H6000V Utility User's Manual.

4 When setting the wireless LAN is complete, remove the wired cable (LAN/USB) and restart the printer.

Setting up Using a USB Connection from a Windows Computer

Necessary Items

Prepare the following items.

- Computer for setting: Windows 10/8/7/Vista
- Utility for setting: Epson TM-H6000V Utility for Windows
- USB cable

Follow the steps below to connect the printer.

- 1 Connect the printer to a PC via the USB cable.**
- 2 Turn on the host computer.**
- 3 Turn on the printer.**
- 4 Start up the TM-H6000V Utility for Windows.**
- 5 Select the printer, and then press the [OK] button.**
If the printer is not displayed, press the "Add Port" button, and then add the printer connected by USB.
- 6 Perform network I/F as well as TCP/IP settings.**
For details on the settings, see the TM-H6000V Utility User's Manual.
- 7 When you have finished making settings, disconnect the USB cable, turn off the printer, and then turn it back on.**

CAUTION

To start wireless LAN communication, be sure to disconnect the USB cable, turn off the printer, and then turn it back on.

Setting up from a Smart Device

Necessary Items

Prepare the following items.

- Device for setting: iOS or Android device
- Utility for setting: Epson TM Utility for iOS/Android

Running Epson TM Utility for iOS/Android

1 Run the Epson TM Utility for iOS/Android.



2 Set from “Wi-Fi Setup Wizard” in the menu.

Setup and Operation Workflow

1. Select the network you want to connect to.
2. Enter the passkey.
3. Perform a test print.

Serial Interface

When connecting to the host computer through a serial interface (RS-232), connect a serial cable to the printer, start the host computer, and then turn on the printer.

NOTE

- When using connectors equipped with screws, tighten the screws on both sides to secure the connectors firmly.
- When using interface cables equipped with a ground line, attach the ground line to the screw hole marked "FG" on the printer.

USB Plus Power Interface

When using a USB Plus Power cable to connect with the host device, connect the flat connector of the USB Plus Power cable to the printer, and the square connector to the device. After starting the host device, turn the printer on.

CAUTION

When using USB Plus Power Interface, be careful of the following points.

- Do not connect an AC adapter and USB (Type-B) simultaneously.
- Do not remove or insert the USB Plus Power cable while the printer is still on.

Connecting the Cash Drawer

CAUTION

- Two driver transistors cannot be energized simultaneously.
- Leave intervals longer than 4 times the drawer driving pulse when sending it continuously.

Required specifications of cash drawer

Specifications of drawers differ depending on manufacturer and/or model. When you use a drawer other than specified, make sure its specification meets the following conditions.

Otherwise, devices may be damaged.

- The load, such as a drawer kick solenoid, must be connected between pins 4 and 2 or pins 4 and 5 of the drawer kick connector.
- When the drawer open/close signal is used, a switch must be provided between drawer kick connector pins 3 and 6.
- The resistance of the load, such as a drawer kick solenoid, must be $24\ \Omega$ or more or the input current must be 1A or less.
- Be sure to use the 24V power output on drawer kick connector pin 4 for driving the equipment.

Drawer Connection Diagram

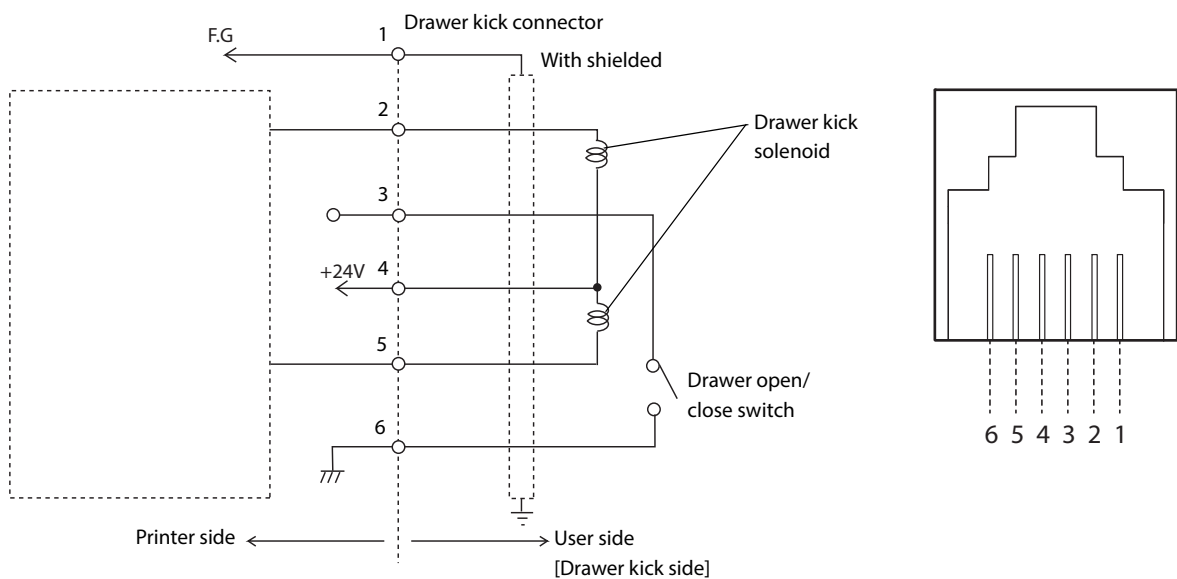

Connecting the drawer kick cable



- Use a shield cable for the drawer kick cable.
- When using cash drawer, make sure to use the power supply for printer (connector pins 4).
- Do not insert a telephone line into the drawer kick connector.
Doing so may damage the telephone line or printer.

Connect the drawer kick cable to the drawer kick connector by pressing firmly until the connector clicks into place.

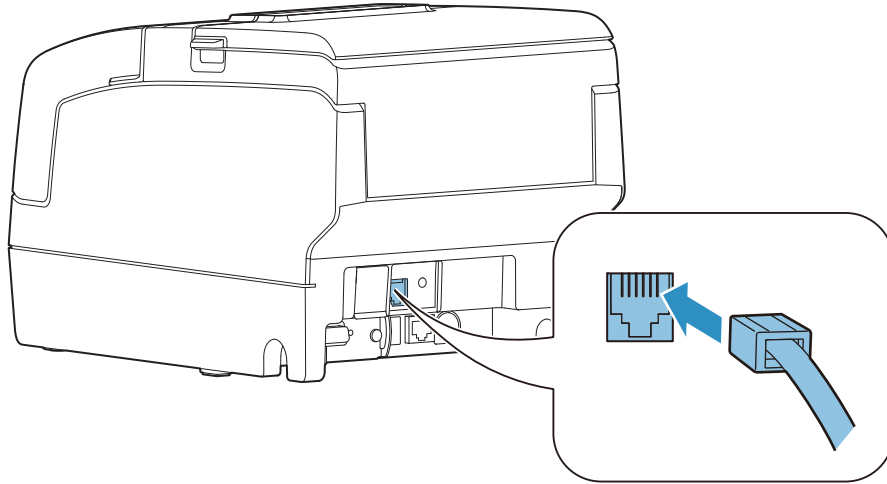

Installing the Customer Display

A customer display and DP-502 (customer display fixing plate) can be installed.

When connecting a customer display, set DIP switch 2-2 on the printer to ON.

See ["Setting the DIP Switches" on page 55](#).

For details, refer to DM-D110/DM-D210 Technical Reference Guide.

NOTE

The printer uses modular connectors specifically designed for the cash drawer. Do not connect these connectors to an ordinary telephone line.

Attaching the Connector Cover

Follow the steps below to attach the connector cover to protect cables.

- 1** Align 2 projections on the top of the connector cover with holes in the back of the printer.
- 2** Push the connector cover forward so that the projections at the bottom of the printer fit properly in the holes in both sides of the connector cover.

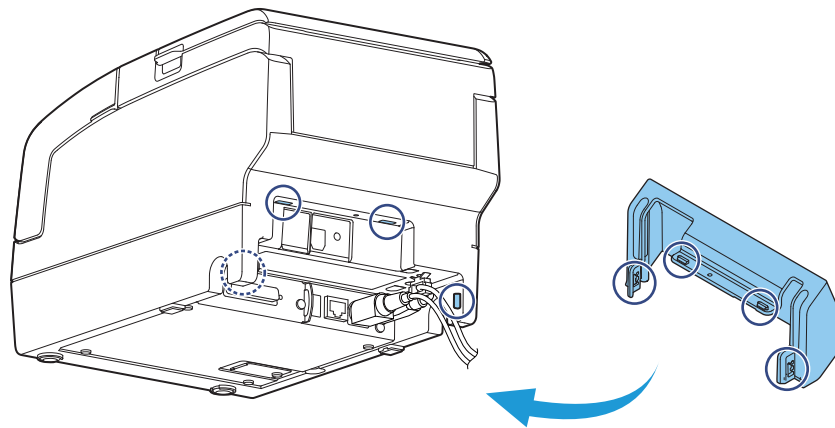

To remove the connector cover, push both sides of the cover inward to remove the holes in both sides of the cover from the projections at the bottom of the printer.

Installing and Replacing the Ribbon Cartridge

NOTE

Be sure to use the specified ribbon cassette.

- 1 Turn the knob on the ribbon cartridge a little in the direction of the arrow marked on the cartridge to remove any slack in the ribbon.

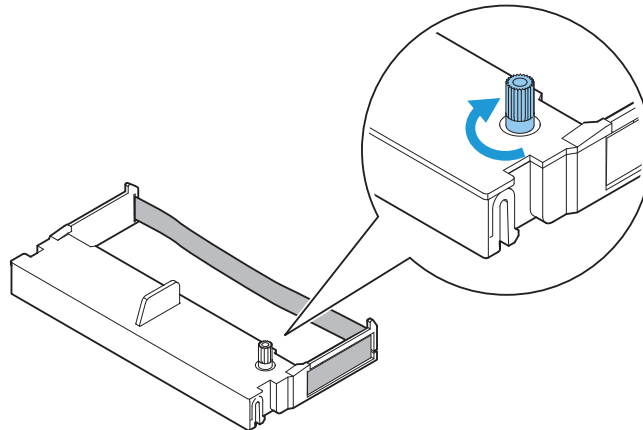

Make sure to note the direction of the arrow marked on the ribbon cartridge when turning the knob. If it is turned in the reverse direction, the cartridge may be damaged.

- 2 Turn on the printer.

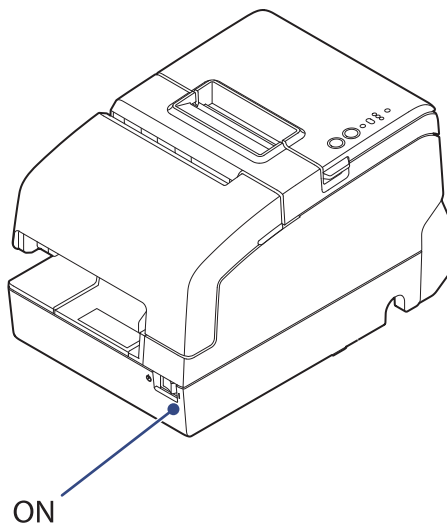

- 3** Open the front cover.

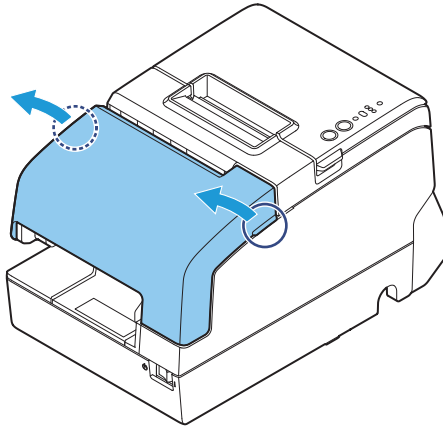

- 4** Remove the used ribbon cartridge, if there is one.

- 5** Insert a new ribbon cartridge until it clicks into place.

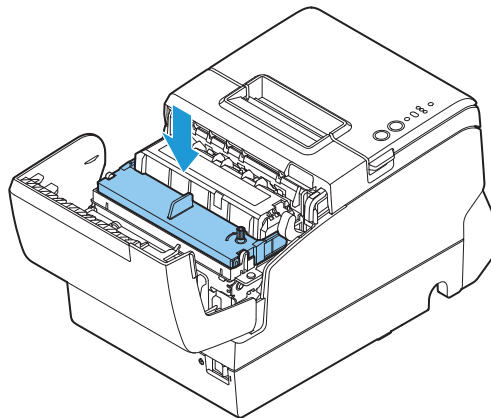

- 6** Turn the knob on the cartridge in the marked direction again to remove any slack in the ribbon.

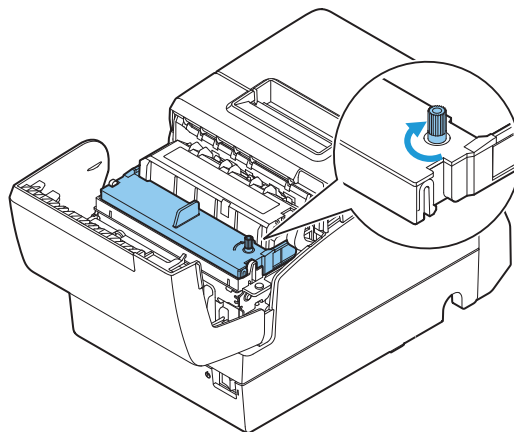

Installing and Replacing the Ribbon Cartridge for Endorsement Printing

If your printer is equipped with an endorsement printer, endorsement printing on slip paper is available. Follow the steps below to install/replace the ribbon cartridge for the endorsement printer.

NOTE

Be sure to use the specified ribbon cassette.

- 1 Turn the knob on the ribbon cartridge a little in the direction of the arrow marked on the cartridge to remove any slack in the ribbon.

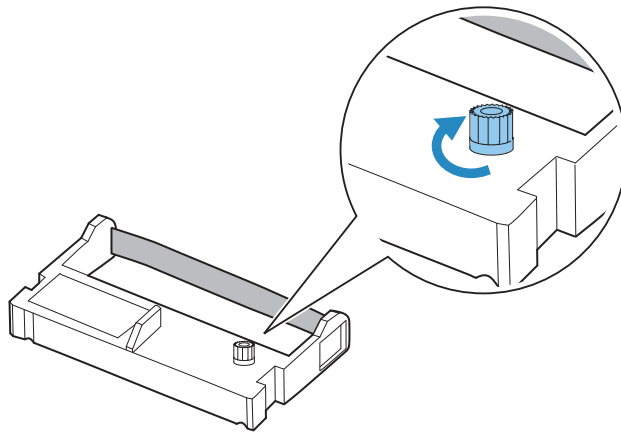

CAUTION

Make sure to note the direction of the arrow marked on the ribbon cartridge when turning the knob. If it is turned in the reverse direction, the cartridge may be damaged.

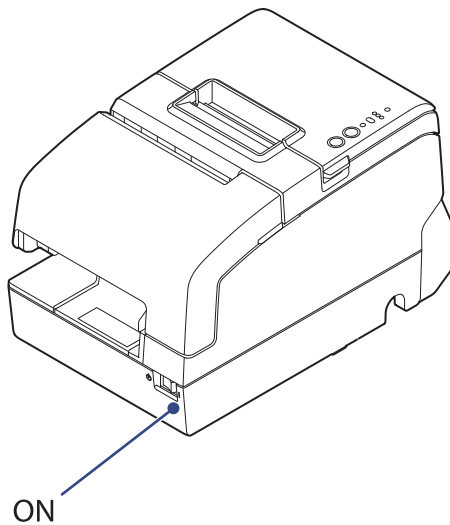
- 2 Turn on the printer.

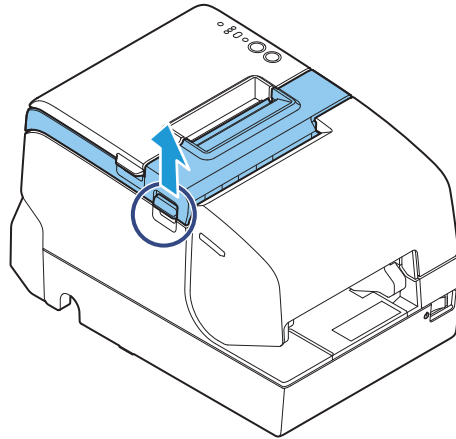

3 Open the receipt unit.



4 Remove the used ribbon cartridge, if there is one.

5 Insert a new ribbon cartridge until it clicks into place.

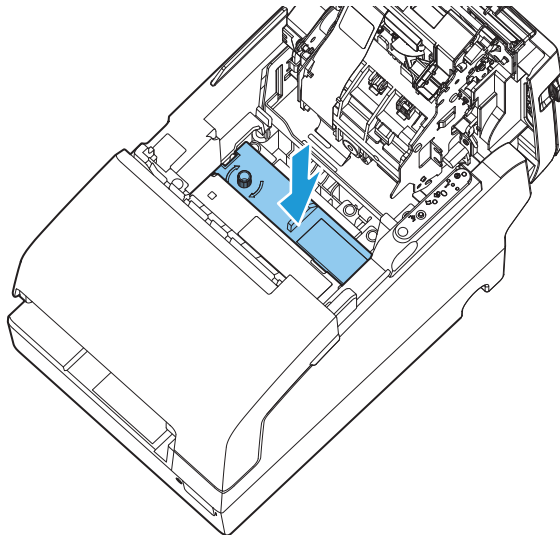

- 6** Turn the knob on the cartridge in the marked direction again to remove any slack in the ribbon.

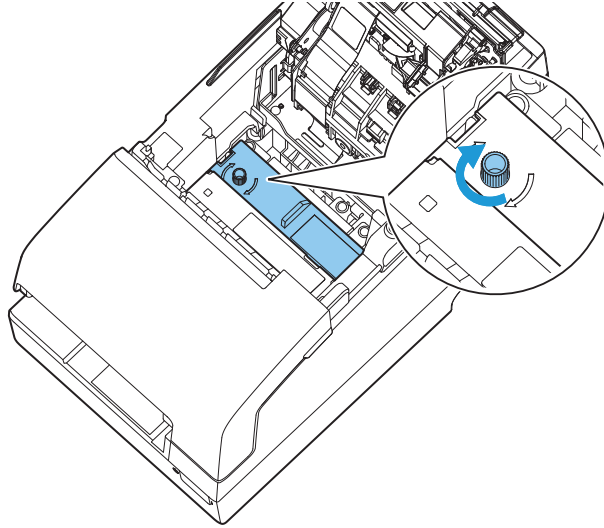

- 7** Close the receipt unit.

Installing the Roll Paper

NOTE

Be sure to use the specified paper.

Follow the steps below to install the roll paper.

- 1** Make sure the printer is turned on.
- 2** Open the roll paper cover.

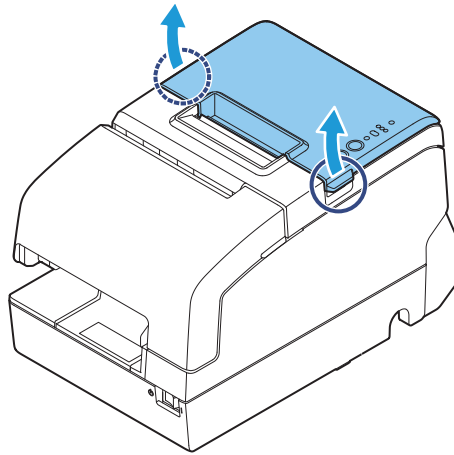

- 3** Insert the roll paper in the correct direction.

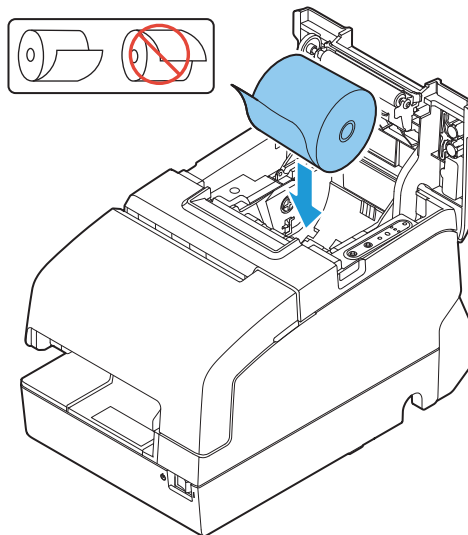

- 4** Pull out some paper, and close the roll paper cover.

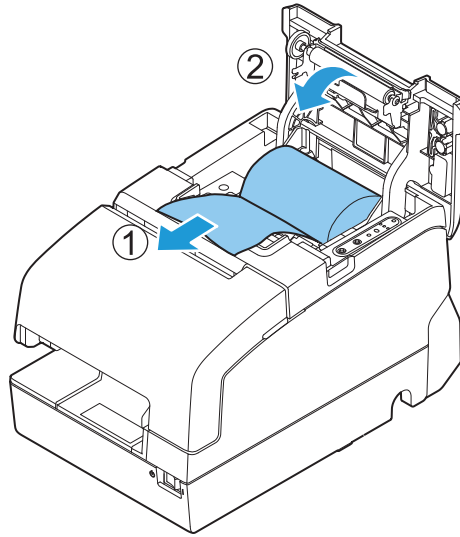

- 5** Tear off the paper with the manual cutter.

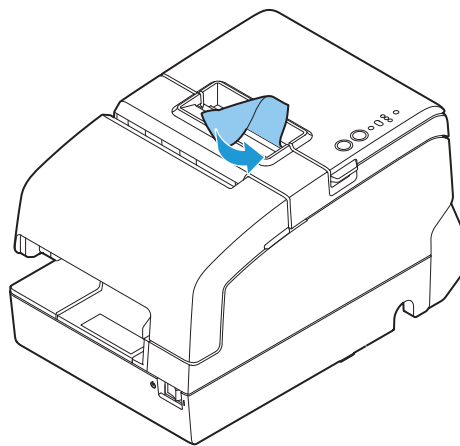

Test Printing

After the printer setup or when the printer is not operating correctly, you can check the printer operation with test printing. If the printer performs pattern printing following the steps below, the printer is operating normally.

Test Printing on Roll Paper

Make sure all the covers are closed, and while pressing the Feed button, turn on the printer. After the printer prints its status and the Paper LED flashes, press the Feed button again to restart the test printing.

Test Printing on Slip Paper

Make sure all the covers are closed, and while pressing the Release button, turn on the printer. After the Slip LED flashes, insert the slip paper. If your printer is equipped with the endorsement printer, the printer prints both sides of the paper.

Both types of test printing are completed when "*** completed ***" is printed.

Attaching the Power Switch Cover

By attaching the power switch cover, you can prevent accidental operations of the power switch.

You can turn on and off the power switch by inserting a sharp-pointed object in the holes on the power switch cover. To detach the cover, use a sharp-pointed object.

To use this cover, install it as shown in the illustration below.

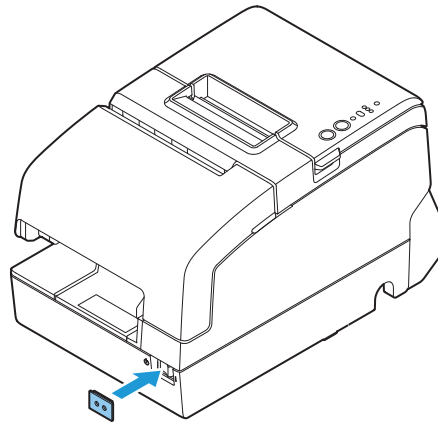

WARNING

If an accident occurs with the power switch cover attached, unplug the power cord immediately. Continued use may cause fire or shock.

Applying the LED Information Label

You can use the LED information label to swiftly learn the status of the printer when an error occurs.

Check the printer's LED on/flashing pattern and identify the error type from the LED information label.

Or, you can scan the QR code using your smart device to check detailed information about the error and the solution.

We recommend applying the LED information label on the reverse side of the front cover following the steps below.

NOTE

- Depending on your printer model, the LED information label may already be applied.

Error Legend	Power	Error			Paper	Slip	Status
		1	2	3			
 https://www.epson-biz.com/manuals/trmh65-led/	●	●	○	○	—	—	Cover is open / Roll paper out
	●	○	○	○	—	●	Insert or remove slip*
	●	●	●	○	—	—	Auto cutter error
	●	●	○	●	—	—	Paper jam
	●	●	●	●	—	—	Printing stop by cover open
	●	—	—	—	—	●	Call for service

○:off ●:on ●:flashing —:LED either on, off or flashing
*All of the covers are closed

- There are 2 types of the LED information label; a label written in English and a label written in French. Some models do not include the label written in French.

1 Open the front cover.

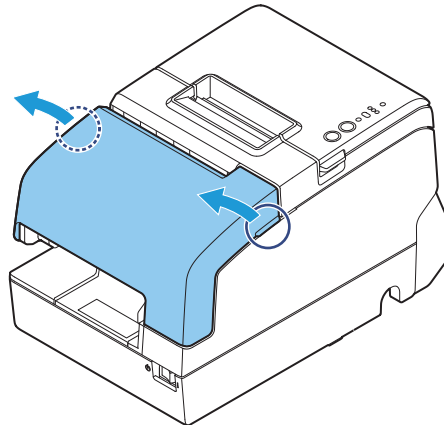

- 2** Apply the LED Information Label in the position in the figure below.

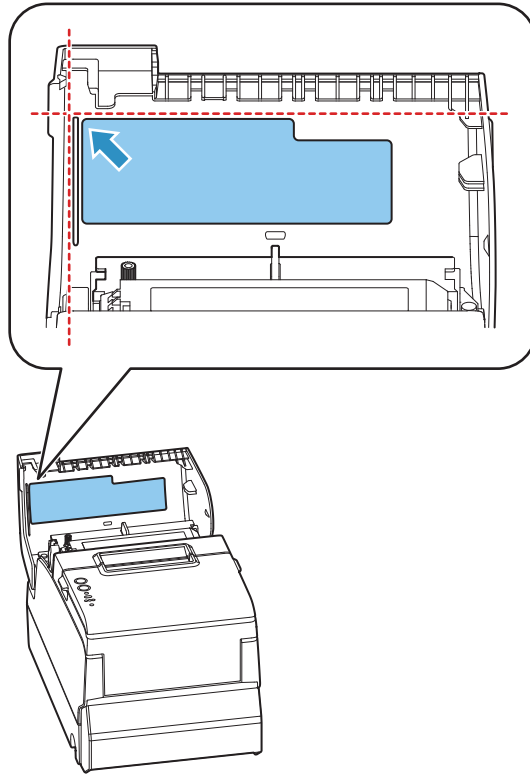

RTC Settings

The time for the RTC (Real Time Clock) may be initialized when starting up for the first time. If the time is initialized, make settings using the Setup Utilities.

For details on making settings using the Setup Utilities, see the TM-H6000V Utility User's Manual.

Adjusting the Paper Roll Near-End Sensor

Below are two situations where a roll paper NE sensor adjustment is required.

- To adjust the detection position to suit the diameter of the roll paper core used.
- To adjust the detection position of remaining amount of paper.

CAUTION

- Since roll paper cores vary slightly in shape, depending on paper roll design and manufacturing tolerances, it is impossible to detect the remaining paper exactly.
- Use roll paper with a core inner diameter of 12 mm {0.47"} and outer diameter of 18 mm {0.71"} so that the NE sensor can detect the remaining paper as accurately as possible.

Follow the steps below to adjust the roll paper near-end detector.

- 1 Open the roll paper cover, and remove the roll paper.
- 2 Loosen the adjustment screw fastening the sensor, and align the upper edge of the positioning plate with the adjustment position.

Adjustment position	Remaining amount of paper (Outer diameter: mm)
Upper	Approximately. 27 {1.06"}
Lower (Default setting)	Approximately. 23 {0.97"}

- 3 Tighten the adjustment screw.
- 4 After adjustment, make sure that the detection lever operates smoothly.

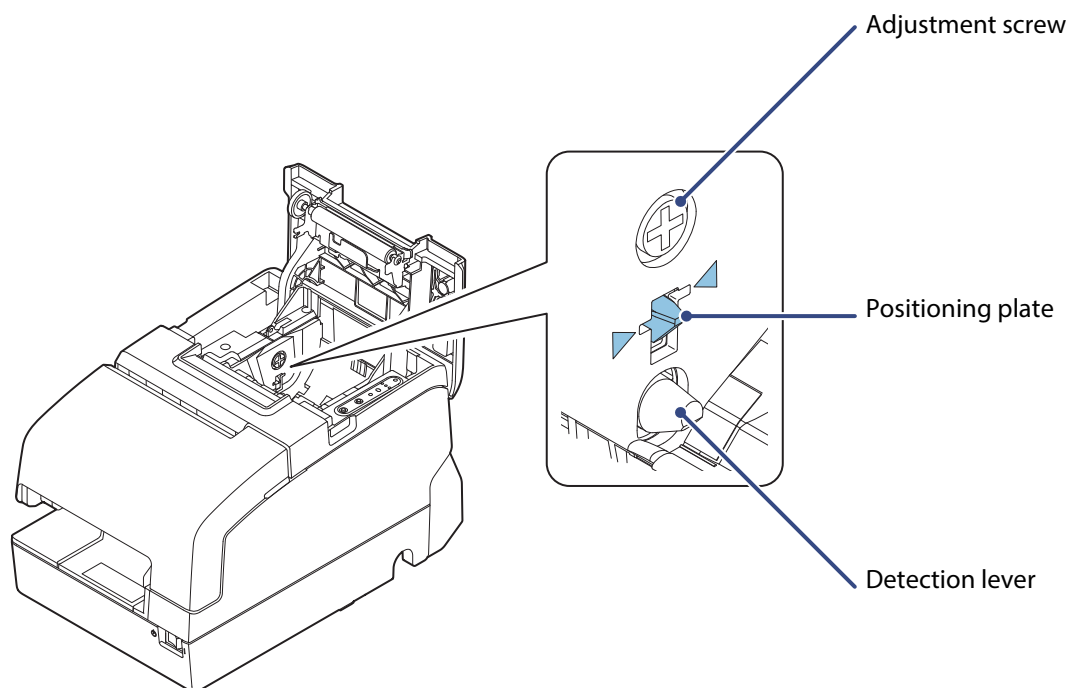

Changing the Paper Width

The printer is initially set to print on 80 mm {3.15"} width paper, but you can change the printer to print on 58 mm {2.28"} width paper by installing the optional roll paper guide.

Follow the steps below to install the roll paper guide.

CAUTION

- Because some parts of the print head and the autocutter contact the platen and they may become worn out in 58 mm printing, once you change the paper width from 80 mm to 58 mm, you cannot change it back to 80 mm.
- When changing the paper width, be sure to change the setting for the paper width with the customized value. To set the customized value, see "[Software Settings](#)" on page 60.

- 1 Open the roll paper cover.
- 2 Align 3 projections on the paper guide with the holes in the roll paper holder, and push it until it clicks into place.

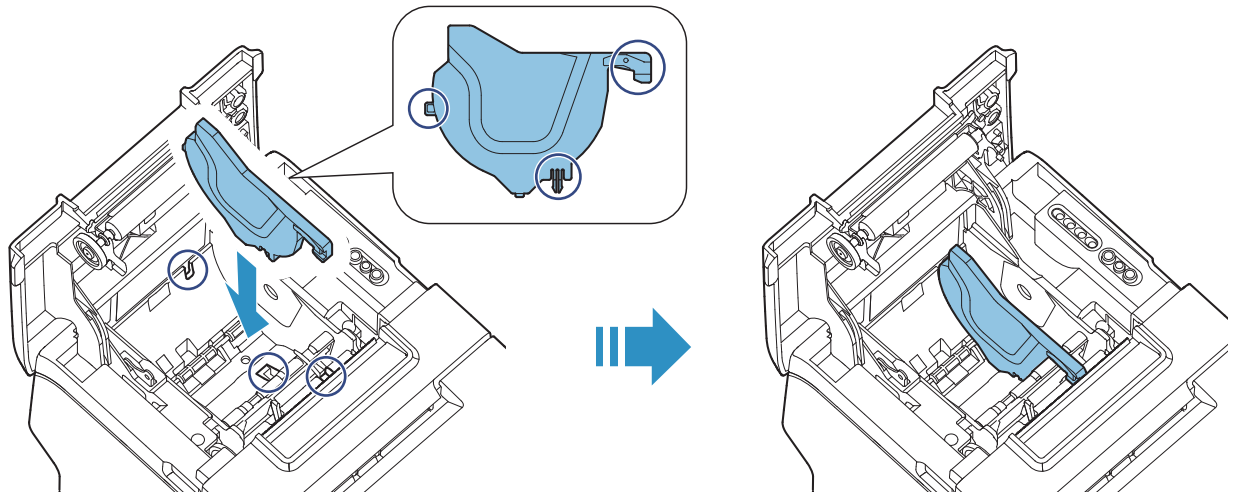

2

Advanced Usage

Setting the DIP Switches

On this printer, you can make various settings with DIP switches. The DIP switches are already set for the current interfaces. Change the setting if necessary. Functions of the DIP switches differ depending on the interface.

Setting Procedure

Follow the steps below to change the DIP switch settings.



- **Before you remove the DIP switch cover, turn off the printer and disconnect all cables.** Otherwise, a short-circuit may cause the printer to malfunction.
- **If you open the DIP switch cover, be sure to close the cover and tighten the screw after adjusting the DIP switch.** Using this product with the cover open may cause fire or electric shock.

CAUTION

- DIP switch settings are enabled only when the power is turned on or the printer is reset via the interface. If the settings are changed after that, the functions will not change.
- Do not change switches that are fixed to ON or OFF. Otherwise, the printer may not operate normally.

- 1** Make sure the printer is turned off.
- 2** Unscrew the screw to remove the DIP switch cover from the base of the printer.

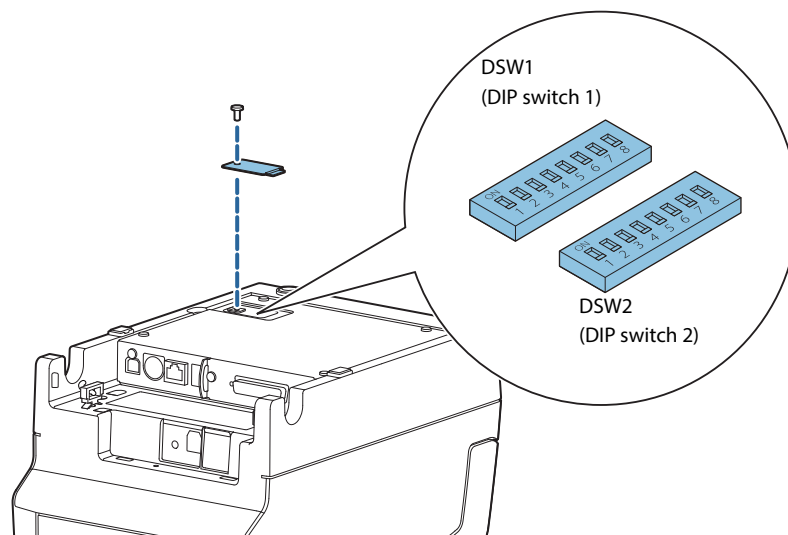

- 3** Set the DIP switches, using the tip of a tool, such as a small screwdriver.
- 4** Replace the DIP switch cover, and screw it in place.

When a Serial Interface is Connected

DIP Switch Bank 1

SW	Function	ON	OFF	Default setting
1-1	Data reception error	Ignored	Prints "?"	OFF
1-2	Receive buffer capacity	45 bytes	4 KB	OFF
1-3	Handshaking	XON/XOFF	DTR/DSR	OFF
1-4	Word length	7 bits	8 bits	OFF
1-5	Parity check	Yes	No	OFF
1-6	Parity selection	Even	Odd	OFF
1-7	Baud rate selections	See the " Transmission Speed (DIP Switches 1-7/1-8) " table below.		ON
1-8				OFF

Transmission Speed (DIP Switches 1-7/1-8)

Transmission speed (bps: bits per second)	SW 1-7	SW 1-8
4800	ON	ON
9600	OFF	ON
19200 (default setting)	ON	OFF
38400 *	OFF	OFF

bps: bits per second

* The setting value of the communication conditions of the serial interface set in the software settings is reflected. The setting value can be specified as 2400, 4800, 9600, 19200, 38400, 57600, and 115200.

DIP Switch Bank 2

SW	Function	ON	OFF	Default setting
2-1	Handshaking (BUSY condition)	Receive buffer full	<ul style="list-style-type: none"> • Offline • Receive buffer full 	OFF
2-2	Customer display (DM-D) connection	Connected	Not connected	OFF
2-3 ~ 2-4	Selects print density	See "Selecting the Print Density (DIP Switches 2-3/2-4)" on page 59.		OFF OFF
2-5	Reserved (Do not change setting)	Fixed to OFF		OFF
2-6	Reserved (Do not change setting)	Fixed to OFF		OFF
2-7	I/F pin 6 reset signal	Enabled	Disabled	OFF
2-8	IF pin 25 reset signal	Enabled	Disabled	OFF

CAUTION

For DIP Switch 2-1 (BUSY condition), see also ["Selecting the BUSY Status"](#) on page 59.

When Another Interface is Connected

DIP Switch Bank 1

SW	Function	ON	OFF	Default setting
1-1	Auto line feed	Always enabled	Always disabled	OFF
1-2	Receive buffer capacity	45 bytes	4 KB	OFF
1-3	Reserved	-	-	OFF
1-4 ~ 1-7	Reserved (Do not change settings)	-	-	OFF
1-8	Reserved	-	-	OFF

DIP Switch Bank 2

SW	Function	ON	OFF	Default setting
2-1	Handshaking (BUSY condition)	Receive buffer full	<ul style="list-style-type: none"> • Offline • Receive buffer full 	OFF
2-2	Customer display (DM-D) connection	Connected	Not connected	OFF
2-3 ~ 2-4	Selects print density	See " Selecting the Print Density (DIP Switches 2-3/2-4) " on page 59.		OFF
2-5	Reserved	-	-	OFF
2-6	Reserved (Do not change settings)	Fixed to OFF		OFF
2-7	Reserved (Do not change settings)	Fixed to OFF		OFF
2-8	Reserved (Do not change settings)	Fixed to ON		ON
		Fixed to OFF *		OFF

* If the interface is a powered-USB

Selecting the Print Density (DIP Switches 2-3/2-4)

Function	SW 2-3	SW 2-4
Do not set	ON	ON
Print density (standard)	OFF	OFF
Print density (medium)	ON	OFF
Print density (dark)	OFF	ON

CAUTION

- If the print density is set to "Medium" or "Dark" level, print speed may be reduced.
- The print density can be set with DIP switches (2-3/2-4) or the software settings. (See "[Software Settings](#)" on page 60.)

Selecting the BUSY Status

With DIP switch 2-1, you can select conditions for invoking a BUSY state as either of the following:

- When the receive buffer is full
- When the receive buffer is full or the printer is offline

CAUTION

In either case above, the printer enters the BUSY state after power is turned on (including resetting with the interface) and when a self-test is being run.

Printer BUSY Condition and Status of DIP Switch 2-1

Printer status		DIP SW 2-1	
		ON	OFF
Offline	During the period after power is turned on (including resetting with the interface) to when the printer is ready to receive data.	BUSY	BUSY
	During the self-test.	BUSY	BUSY
	When the cover is open.	-	BUSY
	During paper feed with the Feed button.	-	BUSY
	When the printer stops printing due to a paper-end (when printer has run out of roll paper).	-	BUSY
	When waiting for the paper Feed button to be pressed before macro execution.	-	BUSY
	When an error has occurred.	-	BUSY
When the receive buffer becomes full.		BUSY	BUSY

Software Settings

With the memory switches and customized values, which are software settings for this printer, you can set the various functions.

For an outline of the functions, see the following section. Use the Epson TM-H6000V Utility for Windows, Epson TM Utility for iOS/Android, or Software Setting Mode to set the memory switches.

NOTE

The software setting mode is the mode set using the printer's panel. For details on panel operations, see "[Software Setting Mode](#)" on page 75.

Item\Method		Software Setting Mode	TM-H6000V Utility for Window	Epson TM Utility for iOS/Android
Memory Switches	Auto line feed	✓	✓	✓
	Power saving function for USB	✓	✓	✓
	Paper sensors to output paper end signal	✓	✓	✓
	Error signal output	✓	✓	✓
	Select paper sensor(s) to stop printing	✓	✓	✓
	Selection of interface using the customer display	✓	✓	✓
	Power ON information	✓	✓	✓
Customized Values	User NV memory capacity	✓	-	-
	NV graphics memory capacity	✓	-	-
	Roll paper width	✓	✓	✓
	Receipt print density	✓	✓	✓
	Receipt print speed	✓	✓	✓
	Character code table defaults	✓	✓	-
	International character defaults	✓	✓	-
	Command execution during offline	✓	✓	✓
	Interface selection	✓	-	-
	Interface switch wait time	✓	✓	✓
	Main interface selection	✓	✓	✓
	Startup Display	✓	✓	✓
	Power supply unit capacity	✓	✓	✓
Column emulation mode	✓	✓	✓	

Item\Method		Software Setting Mode	TM-H6000V Utility for Window	Epson TM Utility for iOS/Android
Customized Values	Autocutting at roll paper cover close	✓	✓	✓
	Automatic paper reduction	✓	✓	✓
	Auto replacement of font	✓	-	-
	Print density during multi-tone printing	✓	✓	✓
	Method for canceling recoverable error	✓	✓	✓
	Transmission speed for serial interface	✓	✓	-
Cut Error Release Method		-	✓	✓
Logo		-	✓	✓
ePOS-Print		-	✓	✓
ProxyInfo		-	✓	✓
Server Direct Print		-	✓	✓
Status Notification		-	✓	✓
Print Forwarding		-	✓	✓
Network CS Authentication		-	✓	✓
Network Dev Info		-	✓	✓
Ethernet Config		-	✓	✓
Wi-Fi Config		-	✓	✓
SSL/TLS Config		-	✓	-
Certificate Config		-	✓	-
TCP/IP Config		-	✓	✓
SNMP Config		-	✓	✓
Time Config		-	✓	✓
LPR Config		-	✓	✓
Port9100 Config		-	✓	✓
IP/Port Filter Config		-	✓	✓

Functions

Automatic line feed

- Normally disabled (default setting)
- Normally enabled

USB power saving function

- Enabled (default setting)
- Disabled

Paper sensors to output paper end signal

- Roll paper out detector (default setting)
- Disabled

Error signal output

- Enabled (default setting)
- Disabled

Select paper sensor(s) to stop printing

- Enabled (default setting)
- Disabled

Selection of interface using the customer display

Specify the printer interface for when using the customer display.

- Serial interface only.
- All interfaces that can be used. (default setting)

Power ON information

- Enabled
- Disabled (default setting)

User NV memory capacity

Select one of the following.

1KB (default setting)/ 64KB/ 128KB/ 192KB

NV graphics memory capacity

Select one of the following.

None (0KB)/ 64KB/ 128KB/ 192KB/ 256KB/ 320KB/ 384KB (default setting)

Roll paper width

- 80mm (default setting)
- 58mm

CAUTION

- Be sure to install the roll paper guide (model: PG-58II) when you select the 58 mm paper width. (See "[Changing the Paper Width](#)" on page 54.)
- Because some parts of the print head and the autocutter contact the platen and they may become worn out in 58 mm printing, once you change the paper width from 80 mm to 58 mm, you cannot change it back to 80 mm.

Receipt print density

Selectable from 70% to 130% (5% increment)

Default setting: Depends on the DIP switch settings

The specified original paper types and recommended print densities are as indicated below.

Depending on the paper type, it is recommended to set the print density as shown in the table below for the best print quality.

Original Paper type	Density	Print speed
AF50KS-E	4 (85%)	13 (300 mm/sec)
P220AGB-1	5 (90%)	13 (300 mm/sec)
TF50KS-EY	5 (90%)	14 (350 mm/sec)
P35524	6 (95%)	13 (300 mm/sec)
P160R, KT55FA	7 (100%)	14 (350 mm/sec)
TF60KS-EY, PD190R, KT48FA, F5041(55), F5041(48)	7 (100%)	13 (300 mm/sec)
P30521, P30523, P31523	8 (100%)	13 (300 mm/sec)

NOTE

- When the print density level is increased, print speed may be reduced. When printing at a density of 115% or more and below a room temperature of 15°C, the speed drops to less than 200 mm/sec.
- When setting the print speed to level 14, use customized values to set the print density.

Receipt print speed

Selectable from levels 1 to 14 (Slow ~ Fast)

Default setting*: level 13 or 14

* Varies depending on the model.

NOTE

Depending on print conditions, such as print duty, print head temperature, and data transmission speed, print speed is automatically adjusted, which may cause white lines due to intermittent print (the motor sometimes stops). To avoid this, keep the print speed constant by setting it lower.

Character code table defaults

Selectable from 43 pages including user defined page

Default setting: PC437: USA, Standard Europe

International character defaults

Selectable from 18 sets

Default setting: USA

Command execution during offline

- Enabled
- Disabled (default settings)

Interface selection

- Fixed to UIB
- Fixed to built-in USB
- Fixed to Ethernet /Wi-Fi (When installing an interface)
- Auto: Built-in USB automatic switching
- Multiple: All interfaces enabled (default setting)

Interface switch wait time

Select from 1 to 10 seconds (in intervals of 1 second)

1 second (default setting)

Main interface selection

- Auto: interface that receives data first (default setting)
- USB
- Wi-Fi or Ethernet
- No main connection I/F

Startup Display

- Enabled
- Disabled (default setting)

Power supply output

Selectable from levels 1 to 3 low power load

Default setting: level 3

Column emulation mode

- Standard mode (default setting)
- 48 column mode

Autocutting at roll paper cover close

- Cuts
- Does not cut (default setting)

Automatic paper reduction

Extra upper space reduction

- Disabled (default setting)
- Enabled

Extra lower space reduction

- Disabled (default setting)
- Enabled

Line space reduction rate

- Not reduced (default setting)
- Reduce 25%
- Reduce 50%
- Reduce 75%

Line feed reduction rate

- Not reduced (default setting)
- Reduce 25%
- Reduce 50%
- Reduce 75%

Amount of reduction in character height

- Not reduced (default setting)
- Reduce 25%
- Reduce 50%
- Reduce 75%

Amount of reduction in barcode height

- Not reduced (default setting)
- Reduce 25%
- Reduce 50%
- Reduce 75%

Auto replacement of font

- Does not replace (default setting)
- Font A
- Font B
- Font C

Print density during multi-tone printing

Selectable from 70% to 130% (5% increment)

100% (default setting)

Method for canceling recoverable error

- Command only (default setting)
- Command + Close cover

Setting and reference items shared by Ethernet/Wi-Fi

Item	Parameter	Default setting	TM-H6000V Utility		Web Browser		Status Sheet
			Reference	Setting	Reference	Setting	Reference
IP Address		192.168.192.168 *	✓	✓	✓	✓	✓
Subnet Mask		255.255.255.0 *	✓	✓	✓	✓	✓
Default Gateway Address		0.0.0.0 *	✓	✓	✓	✓	✓
Acquiring the IP Address	Manual / Auto (DHCP)	Auto (DHCP)	✓	✓	✓	✓	✓
APIPA	Enable/Disable	Disable	✓	✓	✓	✓	-
ARP+Ping	Enable/Disable	Disable	✓	✓	✓	✓	-
Administrator Name	(Up to 255 characters)	" " (no value)	✓	✓	✓	✓	-
Location/Person	(Up to 255 characters)	" " (no value)	✓	✓	✓	✓	-
Password	(Up to 20 characters)	"epson"	✓	✓	✓	✓	-
Standard Community Name	read only	"public"	-	-	✓	-	-
Community Name (read only)	(Up to 31 characters)	" " (no value)	✓	✓	✓	✓	-
Community Name (read/write)	(Up to 31 characters)	" " (no value)	✓	✓	✓	✓	-
Wellknown Community Name	Enable/Disable	Enable	✓	✓	✓	✓	-
IP Trap1	Enable/Disable	Disable	✓	✓	✓	✓	-
IP Trap2	Enable/Disable	Disable	✓	✓	✓	✓	-
Community Name (IP Trap #1)	(Up to 31 characters)	" " (no value)	✓	✓	✓	✓	-
Community Name (IP Trap #2)	(Up to 31 characters)	" " (no value)	✓	✓	✓	✓	-

Item	Parameter	Default setting	TM-H6000V Utility		Web Browser		Status Sheet
			Reference	Setting	Reference	Setting	Reference
IP Trap #1 Address	-	0.0.0.0	✓	✓	✓	✓	-
IP Trap #2 Address	-	0.0.0.0	✓	✓	✓	✓	-
Socket Timeout	1-300 sec / 0 (no timeout)	90 sec	✓	✓	✓	✓	-
Time Server Status	Success / Failure / Invalid	Invalid	✓	✓	✓	✓	✓
Time Server Address	-	0.0.0.0	✓	✓	✓	✓	-
IP Filter	Enable/Disable	Disable	✓	✓	-	-	-

* Initial value when "Acquiring the IP Address" is set to "Manual".

Setting and reference items for Ethernet

Item	Parameter	Default setting	TM-H6000V Utility		Web Browser		Status Sheet
			Reference	Setting	Reference	Setting	Reference
Communication mode setting	Auto Negotiation / 10BASE-T Half / 10BASE-T Full / 100BASE-TX Half / 100BASE-TX Full	Auto Negotiation	✓	✓	✓	✓	✓
MAC Address	-	(refer to MAC Label)	✓	-	✓	-	✓

Setting and reference items for Wi-Fi

Item	Parameter	Default setting	TM-H6000V Utility		Web Browser		Status Sheet
			Reference	Setting	Reference	Setting	Reference
SSID	(Up to 31 characters)	EPSON_Printer	✓	✓	✓	✓	✓
WPA/WPA2 Pre-Shared Key (Pass Phrase)	8-63 ASCII characters or max 64 Hexadecimal characters	EpsonNet	-	✓	-	✓	-
MAC Address	-	(refer to WLAN option's Label)	✓	-	✓	-	✓
Network mode	Infrastructure Ad-Hoc	Infrastructure	✓	✓	✓	✓	✓
WLAN Communication Standard	When using OT-WL02 (Infrastructure) 802.11b/g/n Auto (Ad-Hoc) 802.11b/g Auto	(Infrastructure) 802.11b/g/n	✓	✓	✓	✓	✓
	When using OT-WL05 (Infrastructure) 802.11b/g/n 802.11a/n Auto (Ad-Hoc) 802.11b/g 802.11a Auto	(Infrastructure) 802.11b/g/n	✓	✓	✓	✓	✓
Channel *	1 - 13	1	✓	✓	✓	✓	✓
Security Type	None/ WEP (64) WEP (128)/ WPA-PSK (AES)/ WPA2-PSK/ WPA2-Enterprise	WPA2-PSK	✓	✓	✓	✓	✓
Authentication Algorithm	Open System/ Shared Key/ Auto	Open System	✓	✓	✓	✓	-
Default WEP Key	key1 - key4	key1	✓	✓	✓	✓	-
WLAN Power Save	Enable/Disable	Disable	✓	✓	✓	✓	-

* Channel setting is only available for Ad-Hoc mode. Channels available for use vary depending on the country.

Setting/Checking Modes

As well as print mode, the following modes are also provided for making various printer settings and checking items.

- Self-test mode
- NV graphics information print mode
- Receipt Enhancement information print mode
- Software settings mode
- Restore default values mode
- Interface setup mode
- TM-Intelligent settings information print mode
- Peripheral Device Information Print Mode
- Hexadecimal dumping mode

The self-test mode or hexadecimal dumping mode is selected depending on the operation performed when the power is turned on.

NV graphic information print mode, Receipt Enhancement information print mode, Software settings mode, and Restore default settings mode are selected depending on the Feed button operation performed during a self-test.

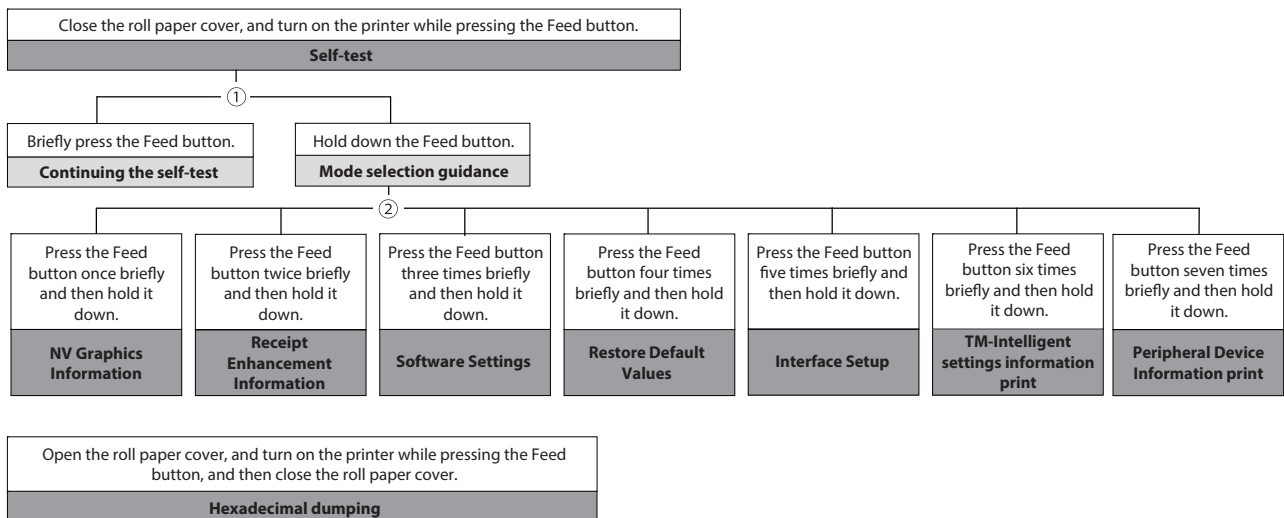

In 1 and 2, the following guidances are printed, the Paper LED flashes, and instructs the user's operations.

1. Continuing self-test guidance

Select Modes by pressing Feed Button.
Continue SELF-TEST: Less than 1 second
Mode Selection : 1 second or more

2. Mode selection guidance

Mode Selection

Modes

- 0: Exit and Reboot Printer
- 1: NV Graphics Information
- 2: Receipt Enhancement Information
- 3: Customize Value Settings
- 4: Restore Default Values
- 5: Interface Setup
- 6: TM-Intelligent Information
- 7: Peripheral Device Information
- 8 or more: None

Select Modes by executing following procedure.

- step 1. Press the Feed button less than 1 second as many times as the selected mode number.
- step 2. Press Feed button for 1 second or more.

Self-test Mode

You can check the following items using the self-test.

- Product name
- Control firmware version
- Product serial number
- Interface information
- Customer display setting
- Built-in character fonts
- Automatic line feed setting
- Print density setting
- Usable device
- Recovery point information
- Maintenance information
- DIP switch settings

Follow the steps below.

- 1 Close the roll paper cover.**
- 2 While pressing the Feed button, turn on the printer. (Hold down the Feed button until printing starts.)**
After printing the current print status, a Continuing self-test guidance is printed, and the Power LED flashes.
- 3 Briefly press the Feed button (less than one second) to continue the self-test.**
The printer prints a rolling pattern on the roll paper, using the built-in character set.
After “*** completed ***” is printed, the printer initializes and switches to standard mode.

NV Graphics Information Print Mode

Prints the following NV graphic information registered to the printer.

- Capacity of the NV graphics
- Used capacity of the NV graphics
- Unused capacity of the NV graphics
- Number of NV graphics that are registered
- Key code, number of dots in X direction, number of dots in Y direction to be defined.
- NV graphics data

NOTE

For details on NV graphics, see "[NV Graphics Memory](#)" on page 22.

Follow the steps below.

- 1 After running a self-test, hold down the Feed button for at least one second, and then select the Mode selection.**
The Mode selection guidance is printed, and the Paper LED flashes.
- 2 After briefly (less than one second) pressing the Feed button once, hold it down for at least one second, to print the NV graphics information.**
After information printing, the Mode selection guidance is printed again.
- 3 To finish, turn off the power, or select "Exit and Reboot Printer".**

Receipt Enhancement Information Print Mode

You can check the following items using the R/E information mode:

- Automatic top logo setting
- Automatic bottom logo setting
- Extended settings for automatic top/bottom logo

Follow the steps below.

- 1 After running a self-test, hold down the Feed button for at least one second, and then select the Mode selection.**
The Mode selection guidance is printed, and the Power LED flashes.
- 2 After briefly (less than one second) pressing the Feed button twice, hold it down for at least one second, to print the R/E information.**
After information printing, the Mode selection guidance is printed again.
- 3 To finish, turn off the power, or select "Exit and Reboot Printer".**

Software Setting Mode

Set the printer's memory switches and customized values.

- Print density
- Print speed
- Auto reduction of amount of paper to use
- Enabling/disabling paper autocutting at cover close
- Paper width setting
- Character Code/Auto replacement of font
 - Default Character CodePage
 - Default International Character Set
 - Auto replacement of font
- Interface Selection
- Interface setting
 - Communication conditions using a serial interface
 - Communication conditions using a USB interface
 - Interface switch wait time
 - Main interface selection
 - Automatic line feed
 - Enabling/disabling Display when interface is activating
- Command execution (offline)
- Power supply capacity
- Other settings
 - Printer model name
 - LED indicator when I/F starting
 - Column Emulation
 - Error Control
 - Power on notice
 - NV Capacity

NOTE

For details on the memory switches and customized values, see ["Software Settings" on page 60](#).

Follow the steps below.

1 After running a self-test, hold down the Feed button for at least one second to enter the Mode selection.

The Mode selection guidance is printed, and the Paper LED flashes.

2 Briefly press the Feed button three times (less than one second), hold it down for at least one second to enter the Software settings mode (Customized value setting).

The Software setting mode guidance is printed, and the Paper LED flashes.

3 After briefly pressing the Feed button (less than one second) for the number of times shown in the print result, hold down the button for more than one second to select the setting items.

The setting selected as the setting item, the current settings and default settings are printed.

Depending on the setting item, you may need to continue selecting the setting item before the settings are printed.

CAUTION

When set to a value other than those in the software setting mode, the current settings are not printed.

4 Select a setting by briefly pressing the Feed button (less than one second) for the number of times applicable to the setting, and then hold down the button for more than one second to confirm your selection.

After saving the settings, the Software setting mode guidance is printed, and the Paper LED flashes.

5 To close Software setting mode, turn off the printer, or select “Exit” to return to Mode selection guidance, and then select “Exit and Reboot Printer”.

NOTE

- To select 0 as the item number, hold down the Feed button until printing starts.
- If the button is pressed a number of times that is not displayed by the Setup guidance, the operation is invalid and the same guidance is printed.

Restore Default Values Mode

In Restore default values mode, following values saved on NV Memory will be set back to default settings. When any error occurs, you can use to specify the reason.

Setting Contents	Setting Items	Restore Default Values and Delete Defined Data
Customized value	✓	✓
Memory switch	✓	✓
R/E (Receipt Enhancement) settings	✓	✓
Communication condition of USB interface	✓	✓
Communication condition of network interface	✓	✓
TM-Intelligent function settings	✓	✓
NV graphics	-	✓
NV bit image	-	✓
User-defined page	-	✓
User NV Memory	-	✓
<i>Bluetooth</i> low energy technology settings	-	✓

Follow the steps below.

- 1 After running a self-test, hold down the Feed button for at least one second to enter the Mode selection.**
The Mode selection guidance is printed, and the Paper LED flashes.
- 2 Briefly press the Feed button four times (less than one second), hold it down for at least one second to enter the Restore Default Values.**
The guidance is printed.
- 3 When only restoring the default settings:**
Briefly press the Feed button once (less than one second), hold it down for at least one second. (Hold down the Feed button until the message of restore completion is printed.)

When restoring default settings and deleting user defined data:
Briefly press the Feed button twice (less than one second), and then hold it down for at least one second. (Hold down the Feed button until the restoration complete message is printed.)
- 4 To finish, turn off the power.**

Interface Setup Mode

Use this mode to setup the interface and other settings.

Follow the steps below.

- 1 After running a self-test, hold down the Feed button for at least one second to enter the Mode selection.**
The Mode selection guidance is printed, and the Paper LED flashes.
- 2 Briefly press the Feed button five times (less than one second), hold it down for at least one second to enter the Interface Setup mode.**
The guidance is printed.
- 3 After briefly pressing the Feed button (less than one second) for the number of times shown in the print result, hold down the button for more than one second to select the setting items.**

Initialize

Select [Wi-Fi & Ethernet Setup] and select [Initialize] to initialize the network setting parameter. The printer is reset and restarted.

SimpleAP mode (Wi-Fi model)

In Wi-Fi model, select [Wi-Fi & Ethernet Setup] and select [SimpleAP] to start in SimpleAP mode (the same as the factory default setting). The printer is reset and restarted, and it begins printing the "SimpleAP Start" information.

Select this to use Quick connection for Wi-Fi model.

NOTE

For information on the Quick connection function, see "[Simple Setup for Wireless LAN](#)" on page 24.

TM-Intelligent Settings Information Print Mode

This function allows you to print TM-Intelligent setting information currently registered in the printer.

Follow the steps below.

- 1 After running a self-test, hold down the Feed button for at least one second to enter the Mode selection.**
The Mode selection guidance is printed, and the Paper LED flashes.
- 2 Briefly press the Feed button six times (less than one second), hold it down for at least one second to print the TM-Intelligent setting information.**
After information printing, the Mode selection guidance is printed again.
- 3 To finish, turn off the power, or select "Exit and Reboot Printer".**

Peripheral Device Information Print Mode

This function allows you to print information for the device currently connected to the printer.

Wi-Fi adapter information

Follow the steps below.

- 1 After running a self-test, hold down the Feed button for at least one second to enter the Mode selection.**
The Mode selection guidance is printed, and the Paper LED flashes.
- 2 Briefly press the Feed button seven times (less than one second), hold it down for at least one second to print the Peripheral Device Information.**
After information printing, the Mode selection guidance is printed again.
- 3 To finish, turn off the power, or select "Exit and Reboot Printer".**

Hexadecimal Dumping Mode

In hexadecimal dumping mode, data from the host device is printed in hexadecimal numbers and characters. By comparing the print outs and the program, you can check whether or not data is being sent to the printer correctly.

NOTE

- When there are no characters that correspond to the print data, " ." is printed.
- If you press the Feed button when there is less than one line of print data, one line is printed.
- During hexadecimal dumping mode, applications that check the printer status may not operate correctly. The printer only returns the status for the "Real-time transmission status" command.

Follow the steps below.

- 1 Open the roll paper cover.**
- 2 While pressing the Feed button, turn on the printer. (Hold down the Feed button until the Error1 LED turns on.)**
- 3 Close the roll paper cover.**
From this point, all data received by the printer is printed in the corresponding hexadecimal numbers and ASCII characters.

Example of printing in hexadecimal dumping mode:

```
Hexadecimal Dump
To terminate hexadecimal dump,
press FEED button three times.

1B 21 00 1B 26 02 40 40 1B 69 . ! . . & . @ . . i
1B 25 01 1B 63 34 00 1B 30 31 . % . . c 4 . . 0 1
41 42 43 44 45 46 47 48 49 4A A B C D E F G H I J

*** completed ***
```

- 4 To close hexadecimal dumping mode, turn off the printer after printing is complete, or press the Feed button for three times.**

Printing a Status Sheet

Follow the steps below to check the interface settings.

NOTE

When the power LED is flashing, wait until it remains lit to start printing.

Using the Status Sheet Button

NOTE

Only the content for the Ethernet and Wi-Fi interface are printed.

- 1 Check that the printer is turned on.**
Make sure the roll paper cover is closed.
- 2 If there is a connector cover, remove the cover.**
See "[Attaching the Connector Cover](#)" on page 40 for details on removing the connector cover.
- 3 Hold down the status sheet button for at least three seconds.**
The status sheet is printed. After printing, the printer returns to the standard mode.

Using the Feed button

NOTE

Content for the Ethernet, Wi-Fi interface are printed.

- 1 Check that the printer is on.**
- 2 Open the roll paper cover.**
- 3 Hold down the Feed button for at least a one second.**
- 4 Close the roll paper cover.**
The status sheet is printed. After printing, the printer returns to the standard mode.

```

*** Wi-Fi & Ethernet Interface ***

Wi-Fi Status
MAC Address      : Unmounted
SSID : EPSON_Printer
Network Mode     : Infrastructure
Comm Standard    : 802.11b/g/n
Encryption Type  : WPA2-PSK
Link Status      : Unknown
Channel          : Unknown
Transmission     : Unknown
Access Point     : Unknown
Signal Level     : Unknown

Wi-Fi
WF : XXXXXXXXXXXX
DN : TM-H6000V

Ethernet Status
MAC Address      : XX-XX-XX-XX-XX-XX
Physical Layer   : Auto-negotiation
Link Status      : Connect

Ethernet
WF : XXXXXXXXXXXX
DN : TM-H6000V

Network
Soft Version     : XX.XX

TCP/IP Status
Acquiring        : Auto
IP Address       : XXX.XXX.XXX.XX
Subnet Mask      : XXX.XXX.XXX.X
Default Gateway  : X.X.X.X

Service Status
Time Server      : (off)
Server Direct Print : (off)
Status Notification : (off)

Other Status
Date/Time        : 20XX/XX/XX XX:XX:XX
Wi-Fi Device ID  : Unknown
Wi-Fi Region ID  : 0

---Server access testing started---
Please wait for up to 1 minute...

```

```

---Server access test result---

Printer
local_printer
Model            :TM-H6000V
Connection       :Success

Server Direct Print
Server 1
Access Test     :Success
Server 2
Access Test     :Success
Server 3
Access Test     :Success

Status Notification
Access Test     :Success

```

If Power is Turned on During Paper Removal Standby

A status sheet for Slip printer is printed if the power is turned on during paper removal standby.

If this occurs, remove the slip paper. If paper is not set, refer to "[Slip paper is jammed](#)" on page 114 and remove any small pieces of paper and any other foreign material.

Example of printing

Recoverable errors

```

-----
*** Error ***

Cause : (*****)[Error Code]
Position : (*****)

Recovery method :
Open the front cover and pull the blue
lever, then remove the paper.
After that, close the front cover and
recover from the error according to
your system.
If the error can't be resolved please
contact technical support.
-----

```

Waiting for paper removal

```

-----
*** Waiting for slip to be removed ***

Recovery method :
Open the front cover and pull the blue
lever, then remove the paper.
-----

```

NOTE

Depending on the product model, this function may not be supported.

Resetting the Interface Settings

Follow the steps below to reset the interface settings.

NOTE

- You can return the interface settings to their defaults from the Interface Setup mode. See ["Interface Setup Mode" on page 78](#) for details on the Interface Setup mode.
- Only network settings are returned to their defaults.

- 1 Turn off the printer and close the roll paper cover.**
- 2 If the connector cover is attached, remove the cover.**
See ["Attaching the Connector Cover" on page 40](#) for details on removing the connector cover.
- 3 Hold down the status sheet button while turning on the printer.**
A message is printed indicating that resetting is being performed, and the printer restarts.

CAUTION

Hold down the status sheet button until the initialization execution message is printed.

TM-Intelligent Function

This product supports the TM-Intelligent function and has a server direct printing function.

This function can be specified by using the TM-H6000V Utility for Windows. See the TM-H6000V Utility User's Manual for details.

You can also download a dedicated manual and sample programs from our homepage.

Server direct print

The server direct function allows this product to acquire print data from a Web server and then print.

By including print data in a response to request from this product, the Web server application can print to this product or a TM printer on the network.

The features are as follows.

- You can acquire print data from three different URLs.
- Print data is available in ePOS-Print XML format.
- You can use this product to print to TM printers on a network.
- Only the receipt printing function can be used for server direct printing.
Cannot print the slip printing function, validation printing function and endorsement printing function.

Regarding details on server direct printing, see the Server Direct Printing User's Manual.

Application Development Information

This chapter describes how to control the printer and gives information useful for printer application development.

Controlling the Printer

The printer supports the following command systems:

- ESC/POS
- ePOS-Print XML
- ePOS-Device XML

Users can control the printer by using the followings.

- EPSON Advanced Printer Driver
- EPSON OPOS ADK
- EPSON OPOS ADK for .NET
- EPSON JavaPOS ADK
- Epson ePOS SDK
- Server Direct Print

ePOS-Print XML

ePOS-Print XML is the Epson original control command system for POS printers defined in XML. With ePOS-Print XML commands, you can print in environments where http communication is available and from OS applications. For detailed information about ePOS-Print XML, see the ePOS-Print XML User's Manual.

ePOS-Device XML

ePOS-Device XML is an Epson original control command system for POS printers and customer displays. It is defined in XML. Control the customer display that is connected to this printer, and control receipt printing, slip printing, or MICR reading. An application creates a request message in XML format and sends it to this product using socket communications. For detailed information about ePOS-Device XML, see the ePOS-Device XML User's Manual.

ESC/POS

ESC/POS is the Epson original printer command system for POS printers and customer display. With ESC/POS commands, you can directly control all the printer functions, but detailed knowledge of printer specifications or combination of commands is required, compared to using drivers and applications.

For detailed information about ESC/POS commands, see the Product Specifications. Product Specifications is available after contracting the non-disclosure agreement with Epson. For details, please contact the selling agency.

Controlling the Cash Drawer

A pulse output is sent to drawer kick connector pin 2 or pin 5, and you can open the drawer.

You can also check the open/close status of the drawer by checking the signal level of the drawer kick connector pin 3. These controls are executed by a driver or by commands.

ESC/POS Commands

Prepare the output command for the specified pulse and the status transmission command.

For detailed information about ESC/POS commands, see the Product Specifications. Product Specifications is available after contracting the non-disclosure agreement with Epson. For details, please contact the selling agency.

Windows Printer Drivers

You can set so that the drawer opens at the start/end of printing or start/end of a page. For details, see the manual for drivers.

For details on control, see the manual for Status API of the driver.

OPOS (OCX Driver)

Register a cash drawer using the SetupPOS Utility, and control using the OpenDrawer method or the DirectIO function.

For details, see the "EPSON OPOS ADK MANUAL APPLICATION DEVELOPMENT GUIDE Cash Drawer" and the "UnifiedPOS Specification".

OPOS for .NET

Register a cash drawer using the SetupPOS Utility, and control using the OpenDrawer method or the DirectIO function.

For details, see the "EPSON OPOS ADK for .NET MANUAL Application Development Guide Cash Drawer (EPSON Standard)" and the "UnifiedPOS Specification".

JavaPOS

Register a cash drawer using the SetupPOS Utility, and control using the OpenDrawer method or the DirectIO function.

For details, see the "EPSON JavaPOS ADK MANUAL Application Development Guide Cash Drawer (EPSON Standard)" and the "UnifiedPOS Specification".

Epson ePOS SDK

The output command for the drawer kick pulse and the status transmission command are provided in each SDK library. For details, see the user's manuals provided with each SDK.

NOTE

- Whether or not pin 2 or pin 5 operates the drawer kick connector depends on the connected cash drawer.
- You can acquire documents regarding the UnifiedPOS from the following link.
<https://nrf.com/resources/retail-technology-standards/unifiedpos>

Server Direct Print

Prepare the output command for the specified pulse and the status transmission command.

For details, see the "Server Direct Print User's Manual".

Software

The following software is provided for application development.

Development Kits

Software	Description
EPSON OPOS ADK	This OCX driver can control POS peripherals using OLE technology. * Because controlling POS peripherals with original commands is not required on the application side, efficient system development is possible.
EPSON OPOS ADK for .NET	The OPOS ADK for .NET is a POS industry standard printer driver compatible with Microsoft POS for .NET. It allows you to develop applications that are compatible with the UPOS (Unified POS) specification. When developing applications, use a separate development environment such as Microsoft Visual Studio .NET.
EPSON JavaPOS ADK (Windows/Linux)	JavaPOS is the standard specification which defines an architecture and device interface (API) to access various POS devices from a Java based system. Using JavaPOS standard API allows control with Java based applications of functions inherent to each device. A flexible design with Java language and JavaPOS enables many different types of computer systems, such as stand alone or network configuration, to use a same application. You can use JavaPOS to build applications and drivers independently of platforms. This allows flexible configurations using thin clients to meet the system requirements.
Epson ePOS SDK	This is a developer kit to control applications, native applications for smart devices, and printers. This includes libraries, manuals, and sample programs.
for Android	
for iOS	
for Universal Windows apps	
for JavaScript	
Server Direct Print	Server Direct Print function enables the TM printers with SDP (Server Direct Print) support to obtain the print data from the Web server and print the data. The Web server application performs printing by including print data in the response to a print request from the TM printers with SDP support.

*: OLE technology developed by Microsoft divides software into part blocks. The OPOS driver is presupposed to be used with a development environment, such as Visual Basic, unlike ordinary Windows printer drivers. It is not a driver to be used for printing from commercial applications.

You can acquire documents regarding the UnifiedPOS from the following link.

<https://nrf.com/resources/retail-technology-standards/unifiedpos>

Drivers

Software	Description	Operating environment
EPSON Advanced Printer Driver	In addition to ordinary Windows printer driver functions, this driver has controls specific to POS. The Status API (Epson original DLL) that monitors printer status and sends ESC/POS commands is also attached to this driver.	Windows
EPSON TM Virtual Port Driver	This is a serial/parallel-USB/LAN conversion driver to make an Epson TM/BA/EU printer connected via USB or LAN accessible from a POS application through a virtual serial or parallel port. It allows you to directly control devices connected via USB or LAN with ESC/POS commands without making changes in the POS application that controls devices connected via a serial or parallel interface.	Windows

Utilities

Software	Description	Operating environment
TM-H6000V Utility	A utility for checking and changing various printer settings. Use this utility to: <ul style="list-style-type: none"> • Check the current settings • Test operation • Store logos • Set paper saving • Set printing control • Set communication interfaces • Set the network • Set the intelligent function • Save/restore settings 	Windows
Epson TM-H6000V Slip Paper Sensor Adjustment Tool	This tool is for adjusting the slip paper sensor of the TM-H6000V. Use this tool if the Slip LED blinks even though slip paper has been removed from the printer.	Windows
Epson TM Utility	A utility that can be downloaded from the App Store or Google Play. For details about the functions, see "Useful Functions for Smart Devices" on page 25 .	iOS, Android
Epson Deployment Tool	Use to make network and printer settings simultaneously. Allows you to make settings efficiently at the time of introducing TM printers for the first time, or when configuring multiple TM printers at the same time.	Windows
Epson Monitoring Tool	Use to check a list of status for the Epson printers connected to the network. You can also update certificates for multiple printers used for WPA2-Enterprise in a batch.	Windows
TM-H6000V Printer Model Setting Utility	This tool allows you to change the model name for the TM-H6000V to TM-H6000IV or TM-H6000V.	Windows

Software	Description	Operating environment
BmpToRaster	You can convert BMP image files to multi tone or black and white print command data.	Windows
EPSON TMUSB Identifier Utility	This tool allows you to change the USB identification code (USB Serial No.). Setting an identification code before replacement makes it easy to perform replacement if a malfunction occurs.	Windows
TM-H6000V Firmware Updater	This tool allows you to update the firmware for the TM-H6000V.	Windows

Others

Manual	Description
ePOS-Print XML User's Manual	Describes ePOS-Print XML statements. This manual comes with sample programs.
ePOS-Device XML User's Manual	Describes ePOS-Device XML statements. This manual comes with sample programs.
TM-H6000V WebConfig API User's Manual	Describes the API for setting this product's TM-Intelligent function. Refer to this manual when using the API from your application to acquire or change settings.

Download

You can obtain software and manuals from one of the following URLs.

For customers in North America, go to the following web site and follow the on-screen instructions.

<http://www.epson.com/support/>

For customers in other countries, go to the following web site:

<http://download.epson-biz.com/?service=pos>

Handling

This chapter describes basic handling of the printer.



- Be sure to use the specified paper. ("Receipt printing" on page 130)
- Do not insert any paper that has clips or staples. This may cause paper jams and damage.
- Make sure the slip/validation paper is flat, without curls, folds, or wrinkles.

Installing and Replacing Roll Paper

Follow the steps below to install/replace the roll paper.

- 1 Make sure the printer is turned on.
- 2 Open the roll paper cover.

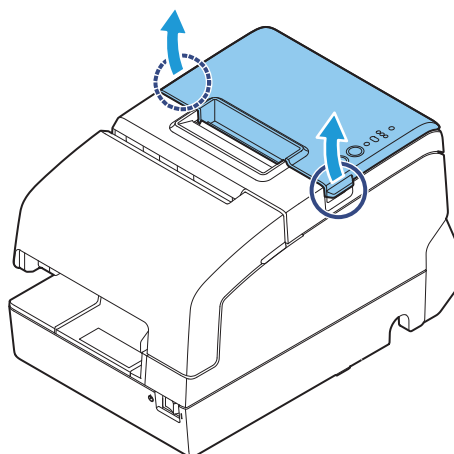

- 3 Remove the used roll paper core, if there is one, and insert the roll paper in the correct direction.

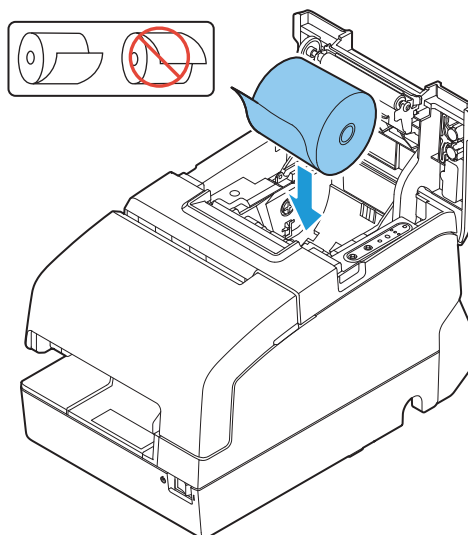

- 4** Pull out some paper, and close the roll paper cover.

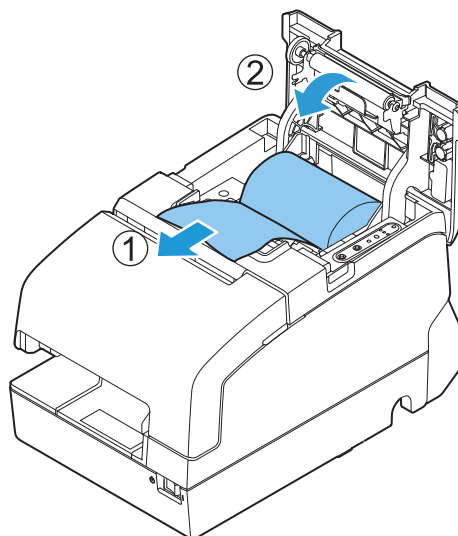

- 5** Tear off the paper with the manual cutter.

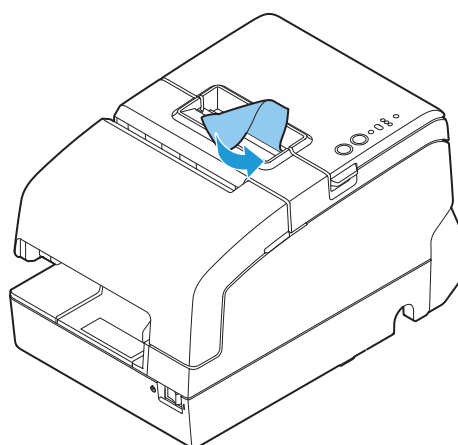

Installing Slip Paper



Do not allow a magnetic card or similar item near the printer if it is an MICR reader model because the MICR model uses a permanent magnet.

When printing on slip paper, follow the steps below to insert the paper.

If your printer is equipped with a MICR reader, MICR reading is available by inserting the check paper so that the MICR characters on the paper are on the right side.

- 1** Make sure the printer is turned on.
- 2** Set the paper so that the right edge of the paper contacts the paper guide on the right and insert the slip paper. Refer to the label affixed to the printer.

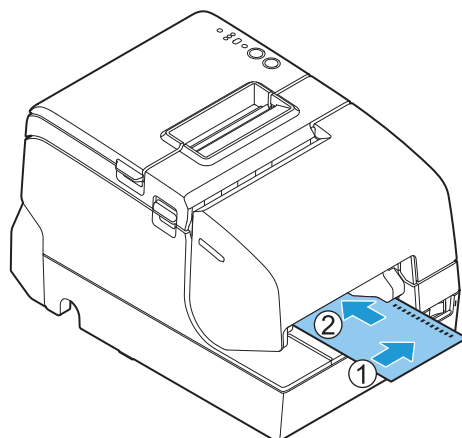

Inserting Validation Paper

If your printer is a validation model, insert the paper in the same way as normal slip paper (See "[Installing Slip Paper](#)" on page 93) or follow the steps below.

- 1** Make sure the printer is turned on.
- 2** Insert the paper with the right paper edge against the right side of the paper guide at the printer top, and insert it as far as it will go.
- 3** Insert the paper straight down until the bottom edge of the paper touches the stopper.

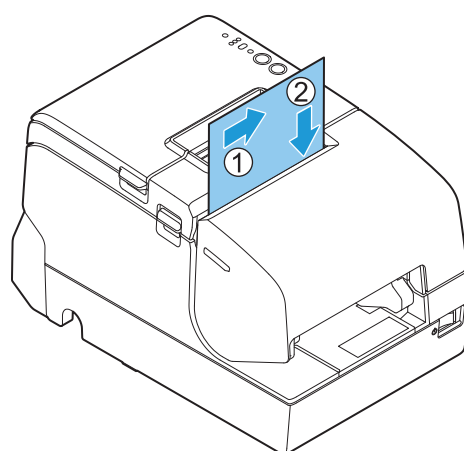

Cleaning the Product

Cleaning the Printer Case

Be sure to turn off the printer, and wipe the dirt off the printer case with a dry cloth or a damp loth.

CAUTION

Never clean the product with alcohol, benzine, thinner, or other such solvents. Doing so may damage or break the parts made of plastic and rubber.

Cleaning the Thermal Head and the Platen Roller

Epson recommends cleaning the thermal head periodically (generally every 3 months) to maintain receipt print quality.

Depending on the roll paper used, paper dust may stick to the platen roller and the paper may not be fed correctly. To remove the paper dust, clean the platen roller with a cotton swab moistened with water. Turn on the product power only after the water has completely dried.



- The thermal head can be very hot after printing. Be careful not to touch it, and let it cool before you clean it.
- Do not damage the thermal head by touching it with your fingers or any hard object.

- 1 Turn off the printer.
- 2 Open the roll paper cover.
- 3 Clean the thermal elements of the thermal head and platen roller with a cotton swab moistened with an alcohol solvent (ethanol or IPA).

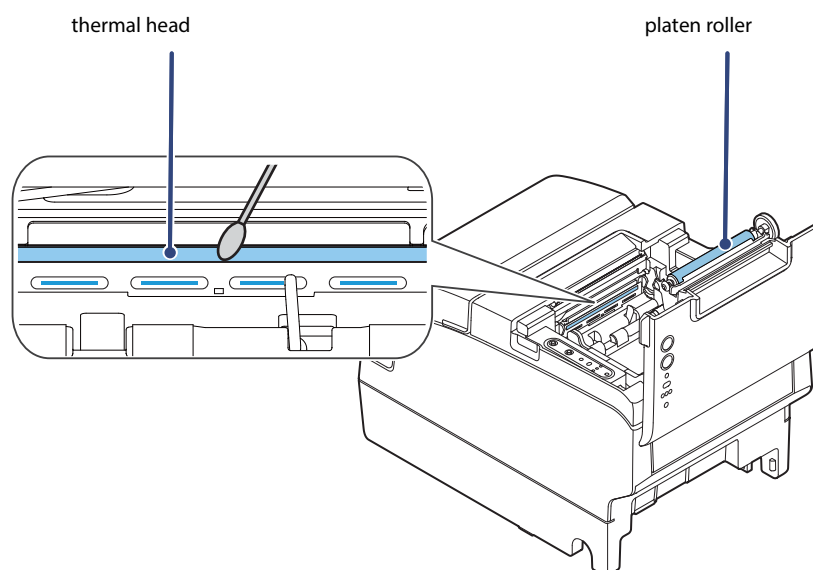

Cleaning the MICR Head

If your printer is equipped with a MICR reader, when the MICR head becomes dirty, the printer cannot read MICR characters normally.

Approximately every year, clean the MICR head with the following or an equivalent commercially available cleaning sheet: KIC Products "Waffletechnology® MICR cleaning card".



- Be sure not to use an adhesive cleaning sheet.
- Be sure that the cleaning sheet is inserted with the correct side up and in the correct direction.
- Use a cleaning sheet only one time; then discard it.

- 1** Make sure the roll paper is installed correctly and the printer is turned off.
- 2** Open the roll paper cover.
- 3** While holding down the Release button, turn the power back on.
- 4** Press the Release button 7 times; then close the roll paper cover.
- 5** After the printer prints "*** RECOGNITION MODE *** Please set check." on the roll paper and the Slip LED flashes, insert the cleaning sheet like standard slip paper.
- 6** Pull the ejected paper straight up out of the printer.
- 7** Turn off the printer to exit the cleaning mode.

Preparing for Transport

Follow the steps below to transport the printer.

- 1** Turn off the printer.
- 2** Remove the power supply connector.
- 3** Remove the roll paper.
- 4** Pack the printer upright.

Troubleshooting

This chapter describes the actions to take when a trouble occurs.

If the trouble cannot be resolved, the product will need to be repaired.

- Identify trouble, and take the necessary actions, according to the LED pattern that is displayed.

See "[LED on/flashing patterns](#)" on page 99.

You can check the actions to be taken on the following pages.





<https://www.epson-biz.com/manuals/tmh6k5-led/>

- Identify trouble based on the symptoms, and take the appropriate actions.





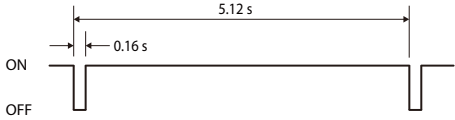

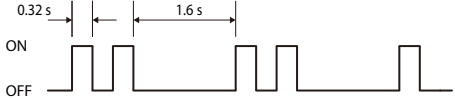































Trouble	Reference
Print Quality Problem (Receipt printer)	See page 103 .
Paper jam (Roll Paper)	See page 113 .
Roll paper cover will not open	See page 117 .
Setting slip paper does not start printing	See page 105 .
Even when slip paper is set, paper is fed and an error occurs	See page 106 .
Slip LED does not turn off even though slip paper is removed	See page 106 .
Paper jam (Slip printer)	See page 114 .
MICR cannot be read	See page 106 .
The customer display does not appear	See page 107 .
The cash drawer does not open	See page 107 .
Printing from the computer is disabled/Printing was suddenly	See page 108 .
Power does not turn on	See page 109 .

LED on/flashing patterns









LED on/flashing patterns

Mark	Status of LED
●	On
○	Off
	Flashing 
	Flashing 
 (2)	Flashing 
-	LED either on, off or flashing

















Printer operating status

Power LED 	Error LED 			Paper LED 	Slip LED 	Status	Solution and Reference
	1	2	3				
						Roll paper near end	The roll paper will run out soon. Prepare a new roll paper.
	-	-	-		-	<ul style="list-style-type: none"> Continued self-test standby Macro execution standby Standby for closing roll paper cover when printing status sheet 	The printer is waiting for user operation. Press the Feed button or close the roll paper cover to continue the process.
				-	-	TM-Intelligent function warning	A connection cannot be established with the server. Check the network-related issues such as cable connections or server operation status.
						Powering off	The printer is shutting down. Wait until the Power LED turns off.
						Power OFF standby	The printer is ready for the power to be turned off with your system. Use the power switch to turn off the power.
				-		Bluetooth searchable (1 minute)	The printer can be found by other Bluetooth-enabled devices for 1 minute after the status sheet has been printed. Search for the printer from the Bluetooth-enabled device and pair the devices during the time that the Power LED flashes.
						Overwriting firmware	The printer firmware overwrite process is in progress. Wait until the printer restarts. CAUTION: Do not turn off the power while the firmware overwrite process is in progress.















































Errors that recover automatically

Power LED 	Error LED 			Paper LED 	Slip LED 	Status	Solution and Reference
	1	2	3				
				-	-	<ul style="list-style-type: none"> Head temperature error Motor driver IC temperature error 	The printer temporarily stops operating because the print head or motor driver has overheated. Wait until the printer resumes operation.

Recoverable errors

Power LED 	Error LED 			Paper LED 	Slip LED 	Status	Solution and Reference
	1	2	3				
				-	-	Autocutter error	Open the roll paper cover and check for any foreign objects. Then clear the error from your system. See "Auto cutter error" on page 110.
				-	-	Roll paper cover open error (during printing)	Properly set the roll paper and then close the roll paper cover. Then clear the error from your system. See "Installing and Replacing Roll Paper" on page 91.
				-	-	Paper jam	Open the front cover and front carriage unit and then check for paper and any foreign objects. See "Paper jam" on page 113.

Unrecoverable errors

Power LED 	Error LED 			Paper LED 	Slip LED 	Status	Solution and Reference
	1	2	3				
						R/W error in memory	Detected an error during memory R/W.
						High voltage error	Detected abnormal voltage (high) in the power source.
						Low voltage error	Detected abnormal voltage (low) in the power source.
						CPU execution error	The CPU executes an incorrect address.
						Internal circuit connection error	Detected an error in the internal circuit connection.
						Communication unit error	Detected an error in wireless communication or the wireless unit, or detected that a non-specified device was connected to the USB connector (Type-A) when the power was turned on.
						Mechanical operation error	Could not detect the position of the platen roller opening/closing mechanism.

Print Quality Problem

Print Quality Problem (Receipt printer)

Vertical white streaks

Cause	Solution and reference
The head is dirty.	Perform head cleaning. See " Cleaning the Thermal Head and the Platen Roller " on page 95.

Noticeable print shading/White lines are present

Cause	Solution and reference
The print speed fluctuates or intermittent printing occurs due to the conditions of data transmission from the host.	Decrease the print speed so that printing does not stop in the middle of a job and the print speed does not fluctuate. See " Software Settings " on page 60.

The print color is too light

Cause	Solution and reference
The print density is not set correctly.	Decrease the print density setting. See " Software Settings " on page 60.
You are using paper other than the specified original paper.	Use the specified original paper.

Print Quality Problem (Slip/Validation/ Endorsement printer)

The paper is dirty

Cause	Solution and reference
The paper is bent or curled.	Use flat paper that is not curled, folded, curved, or wrinkled. Otherwise, the paper could come into contact with the ink ribbon and become dirty.

The print color is too light

Cause	Solution and reference
The ink ribbon color is too light.	Replace the ink ribbon. See "Installing and Replacing the Ribbon Cartridge" on page 41, "Installing and Replacing the Ribbon Cartridge for Endorsement Printing" on page 43.
The paper is too thick, or there are too many sheets of copy paper.	Check the paper specifications. See "Paper Specifications" on page 132.

Setting slip paper does not start printing

Check the Slip LED.

Slip LED is flashing continuously

Cause	Solution and reference
The slip paper is set in a incorrect position.	Check whether the slip paper is inserted straight along the paper guide.

Slip LED is flashing 3 times

Cause	Solution and reference
In check insertion standby if the printer is an MICR model.	Insert the check paper

Slip LED is off

Cause	Solution and reference
A Slip printer has not been selected as the print destination.	Check the application and change the paper source to slip paper.

Slip LED does not change from flashing to lit up

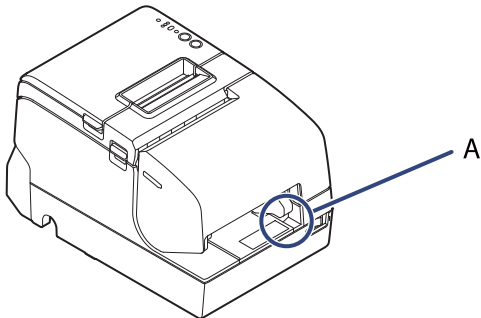
Cause	Solution and reference
The sensor does not detect any paper.	<p>Download the Slip Paper Sensor Adjustment Tool (Windows only), and adjust the sensitivity of the Slip paper sensor (A in the illustration). Refer to the Slip Paper Sensor Adjustment Tool Manual for adjustment procedures.</p> 

Even when slip paper is set, paper is fed and an error occurs

Cause	Solution and reference
The paper being used does not match the printer driver settings.	Check the printer driver settings.

Slip LED does not turn off even though slip paper is removed

Cause	Solution and reference
There are small pieces of paper in the paper path.	Remove any small pieces of paper that are in the paper path (B in the illustration). There is a sensor that detects paper in the paper path (circled in the illustration). The sensor enclosed by the dotted line is not available on some models.
	Confirm that there are no small pieces of paper remaining in the paper path, and then close all of the covers. If the Slip LED still does not stop flashing, download the Slip Paper Sensor Adjustment Tool (Windows only), and adjust the sensitivity of the Slip paper sensor (A in the illustration).

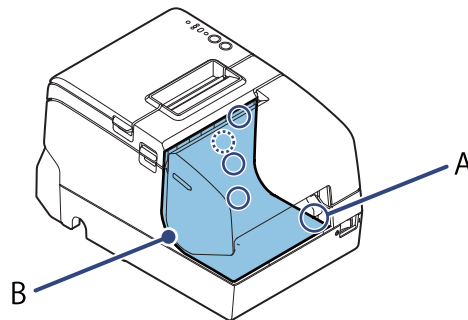

MICR cannot be read

Cause	Solution and reference
The paper insertion position is not correct.	Push the paper fully against the right side.
The paper insertion direction is not correct.	Check the paper direction.
The paper is bent.	Use paper that is not curled, folded, curved, or wrinkled along the edges.
There is a device that emits magnetic fields, such as a display, nearby.	Do not use this product near devices that emit magnetic fields.
The MICR head is dirty.	Perform MICR cleaning. See " Cleaning the MICR Head " on page 96.

The customer display does not appear

Does not appear on the customer display

Cause	Solution and reference
The customer display is not connected.	Check the connection between the customer display and the cable.
DIP switch 2-2 on the printer is OFF.	Set DIP switch 2-2 on the printer to ON. See " Setting the DIP Switches " on page 55.
"Selection of interface using the customer display" in the software settings is not correct.	Configure the setting to "All interfaces that can be used". See " Software Settings " on page 60.
The printer driver and application settings are not correct.	Check the printer driver and application settings.

Text is garbled

Cause	Solution and reference
The transmission speed is not correct.	Set the display's transmission speed to 19200bps.

The cash drawer does not open

Cause	Solution and reference
The cash drawer is not connected.	Check the connection between the cash drawer and the cable.
The cash drawer specifications and drawer port specifications are not correct.	Use the TM-H6000V Utility to check operation. At this time, check the pin number of the signal.
	Set the pin number for opening the printer as indicated in the drawer specifications. See " Required specifications of cash drawer " on page 37.
The printer driver and application settings are not correct.	Check the printer driver and application settings.

Printing from the computer is disabled/Printing was suddenly

USB Connections

Cause	Solution and reference
Poor cable connection.	Check the cables connected to the printer and computer, as well as the power supply cables.
	Unplug the cables, and then plug them back in.
	Change the cables.
Using a USB Hub	Try connecting the printer directly to the computer.
Change the connection port on the computer.	Try changing the connection port on the computer.

LAN Connections

Cause	Solution and reference
Poor cable connection.	Check the cables connected to the printer and computer, as well as the power supply cables.
The printer's network settings have changed.	Print a status sheet to check the settings. See "Printing a Status Sheet" on page 81.
	Initialize the network settings, and then configure the settings again. See "Resetting the Interface Settings" on page 84.
Network Problems	Check with the network administrator.

Wi-Fi Connections

Cause	Solution and reference
Poor wireless LAN cable set connection	Check the connection between the wireless LAN cable set.
The printer's network settings have changed.	Print a status sheet to check the settings. See "Printing a Status Sheet" on page 81.
	Initialize the network settings, and then configure the settings again. See "Resetting the Interface Settings" on page 84.
Network Problems	Check with the network administrator.

Power does not turn on

Cause	Solution and reference
The power is not being supplied.	Check whether the power cable and AC adapter are properly connected to the printer and outlet.

Auto cutter error

Open the roll paper cover, and check for foreign material. Then, perform error recovery from the system you are using.

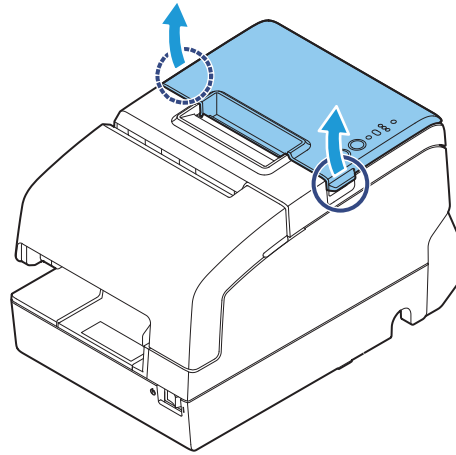

If the roll paper cover will not open, or if the same error occurs even after performing error recovery from the system, use the following procedure to return the cutter blade to its original position, and then perform error recovery.

1 Open the receipt unit.

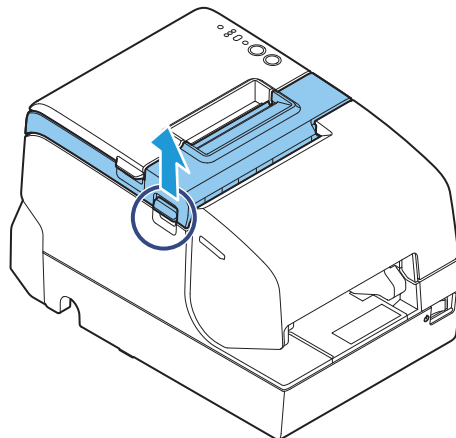

- 2 Use an object with a pointed tip such as a ballpoint pen or tweezers to turn the knob of the autocutter blade in the direction of the arrow until you see a pin in the opening of the frame.

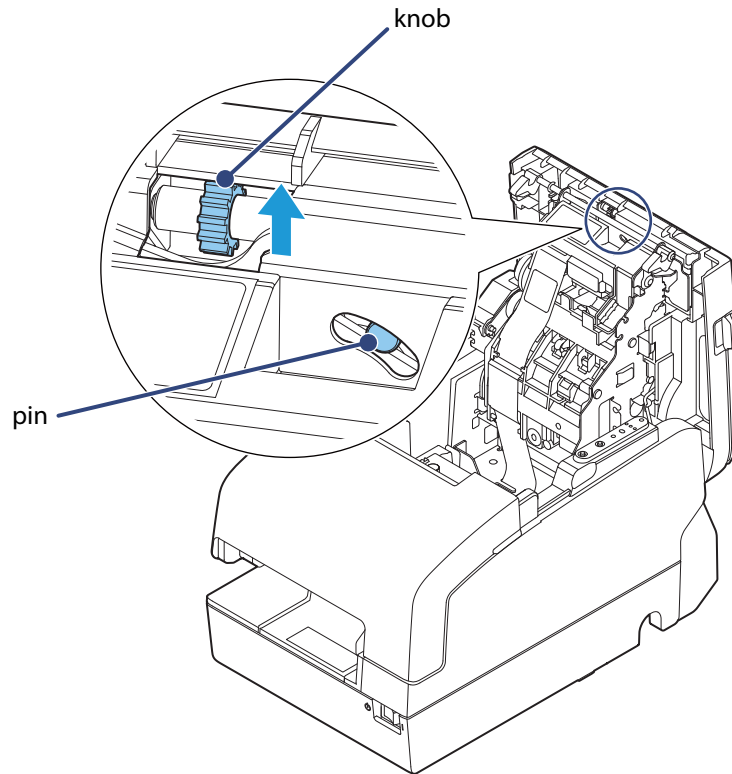

- 3 Open the roll paper cover.

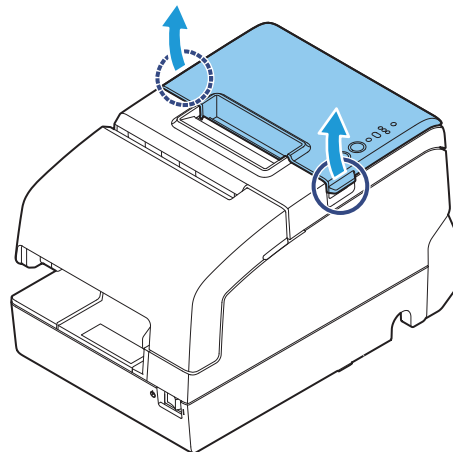

4 Pull out some paper, and close the roll paper cover.

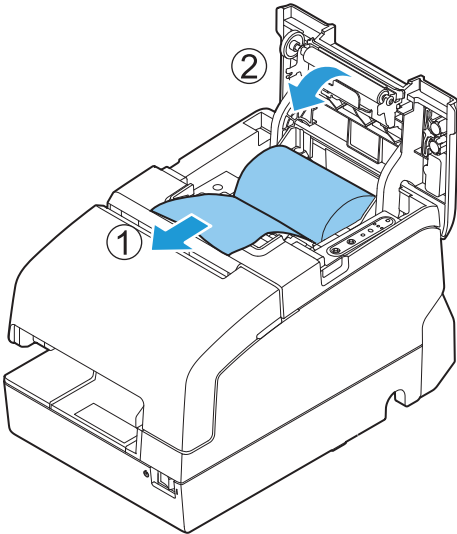

5 Tear off the paper with the manual cutter.

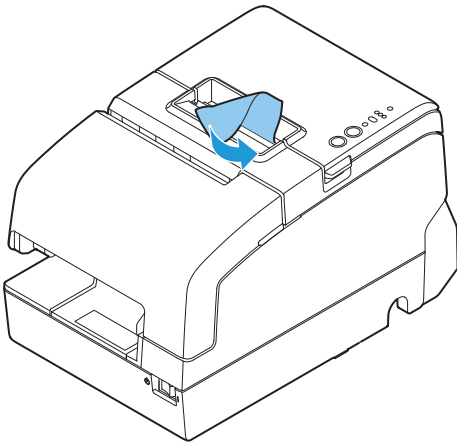

Paper jam

Roll paper is jammed



CAUTION

Do not touch the thermal head, because it can be very hot after printing. Let it cool before you remove the jammed paper.

- 1 Open the roll paper cover.

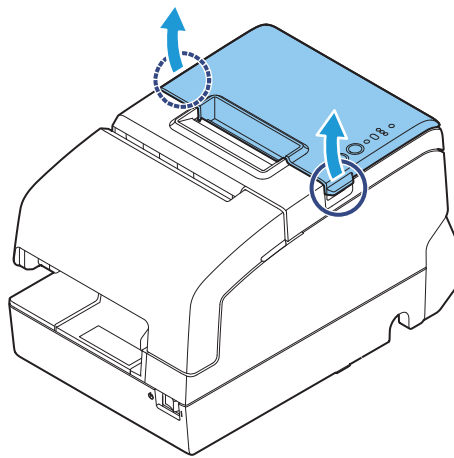

- 2 Remove the jammed paper.

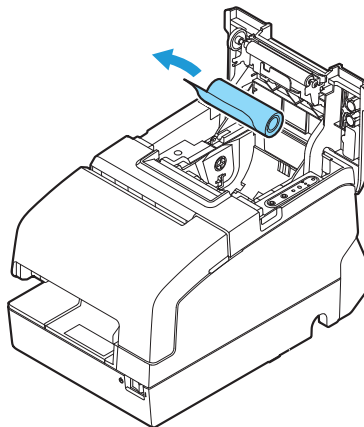

Slip paper is jammed

1 Open the front cover.

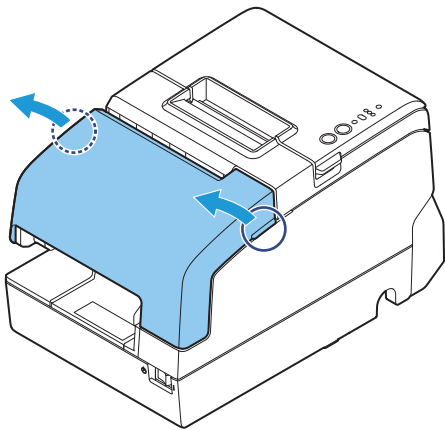

2 Open the front carriage unit using the lever at the right side.

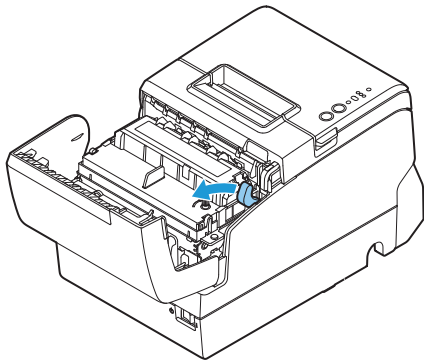

NOTE

When using an endorsement printer, also open the receipt unit.

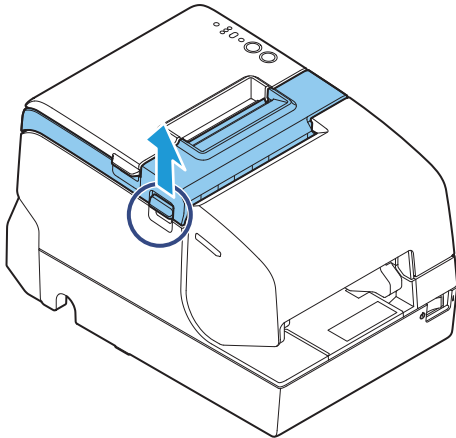

3 Remove the jammed paper.

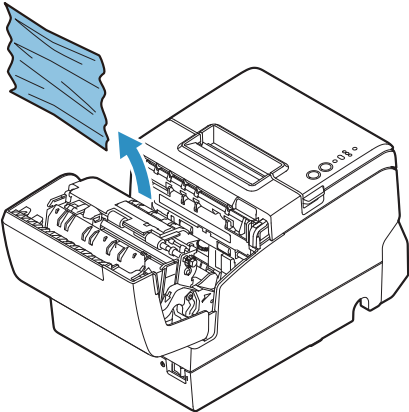

4 Close the front carriage unit using the lever.

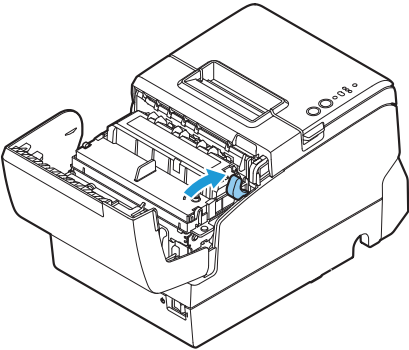

NOTE When using an endorsement printer, also open the receipt unit.

A line drawing of the printer's receipt unit. A blue arrow points to a lever on the top of the unit, indicating it should be pushed down to open the receipt compartment. The printer has 'OO-103' printed on the top right.

- 5 Close the front carriage unit using the lever.

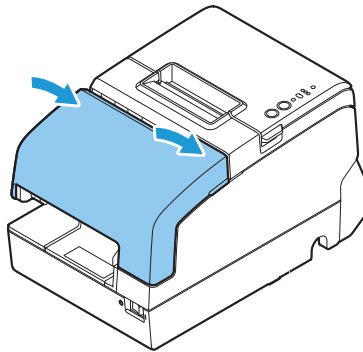

- 6 Then, perform error recovery from the system you are using.

Roll paper cover will not open

When the roll paper cover is locked and will not open, follow the steps below to return the autocutter blade to the normal position to unlock the roll paper cover.

- 1 Open the receipt unit.

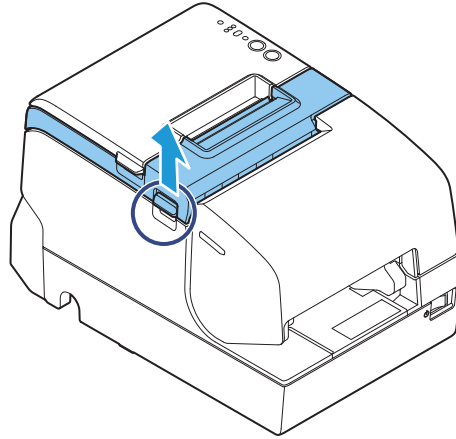

- 2 Use an object with a pointed tip such as a ballpoint pen or tweezers to turn the knob of the autocutter blade in the direction of the arrow until you see a pin in the opening of the frame, as shown in illustration below.

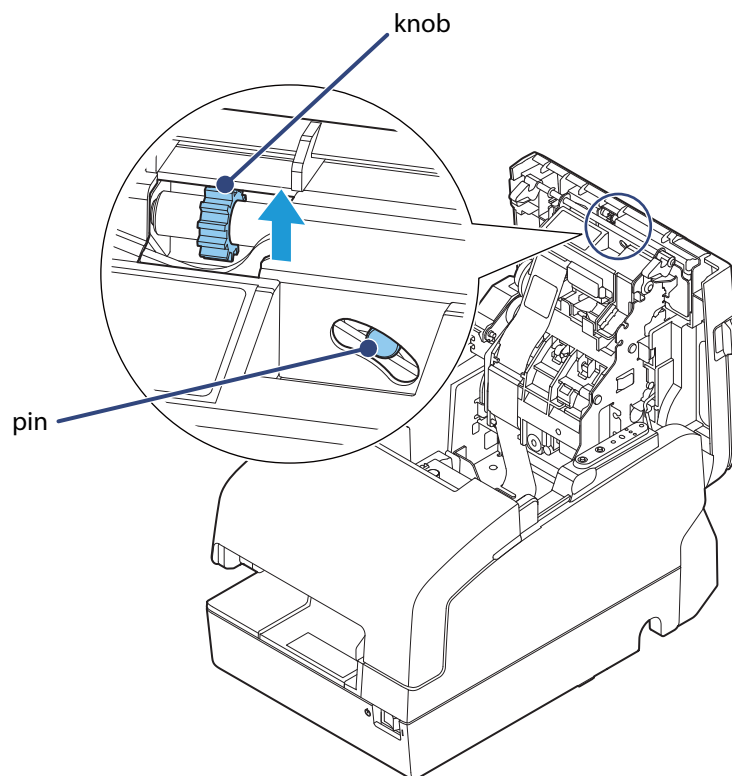

Printing stop by cover open

1 Pull out some paper, and close the roll paper cover.

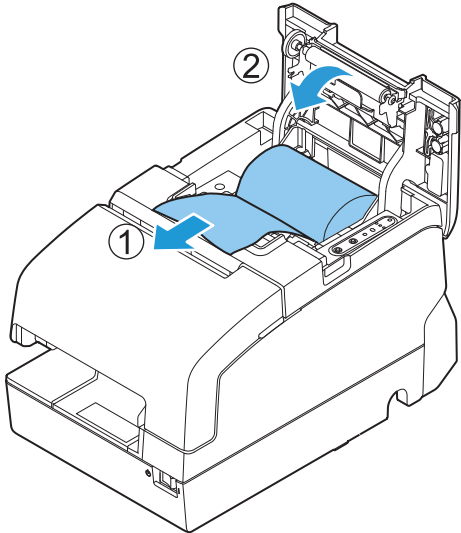

2 Tear off the paper with the manual cutter.

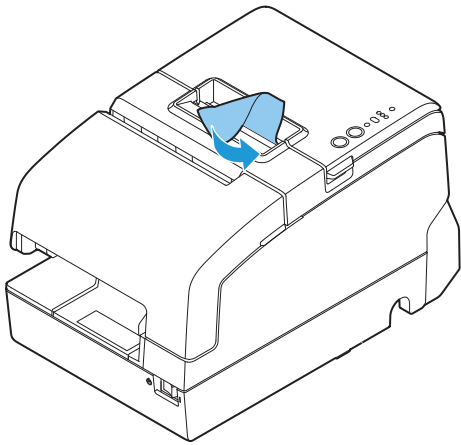

3 Perform error recovery from the system you are using.

CAUTION Do not open the covers during printing or autcutting.

Printing from the computer is disabled/Printing was suddenly

Printer is offline

Remove the cause of going offline.

See ["Online and Offline" on page 19](#).

Reconnect the printer and the computer

1 Check the cable connection.

Check whether the power cable and/or interface cables are properly connected.

2 Reconnect all devices.

- For USB connection
Disconnect the USB cable and then connect it again.
When the computer has multiple USB connectors, reconnect the cable to another connector.
- For serial connection
Disconnect the serial cable and then connect it again.
- For wired LAN
As operation of a device connected with a wired LAN may be unstable, restart the network.
- For wireless LAN
Check the connection status of the wireless LAN unit.

LAN setting

Print a status sheet and check that the settings are correct.

- Correct the settings if not correct.
- Initialize the network settings and specify the settings again.

Check installation of printer driver

Check whether the required software and applications are installed on the computer.

For details about how to check installation of printer driver, refer to the manual for each printer driver.

Power does not turn on

Check whether the power cable and AC adapter are properly connected to the printer and outlet.

Replacement of the TM-H6000IV

The TM-H6000V is designed so that it can smoothly replace the TM-H6000IV. This chapter describes precautions for the replacement.

	TM-H6000V	TM-H6000IV
Receipt print speed	350 mm/s*	300 mm/s
Autocutter	High speed type	-
Reliability	<Receipt printing> Print head 200 km Autocutter 3,000,000 cuts Original Paper type TF50KS-EY, PD160R, KT55FA	<Receipt printing> Print head 150 km Autocutter 2,000,000 cuts Original Paper type PD150R, PD160R
Ethernet interface	Included	Supported by UIB (UB-Exx)
Wi-Fi interface	Supported by option (OT-WL02, OT-WL05)	Supported by UIB (UB-Exx)
NFC	Included	Not included
RTC	Included	Not included
Status sheet	Corresponded	Not corresponded (Some devices implement this function on the interface side.)
Multiple interface	Corresponded	Not corresponded
TM-Intelligent	Corresponded	Not corresponded
Case color	2 colors White and Black	2 colors ECW or EDG
Option	PG-58II: 58 mm width paper guide. TA-6000II: Printer attachment. OT-FT6000: Front tray for aiding insertion of slip paper. OT-DC6000: Cover for protecting the wireless LAN unit. OT-WL02, OT-WL05: Wireless LAN cable set. DM-D110, DM-D210: Customer display. DP-502: Dedicated stand for customer display.	PG-58II: 58 mm width paper guide. TA-6000II: Printer attachment. OT-FT6000: Front tray for aiding insertion of slip paper. DM-D110, DM-D210: Customer display. DP-502: Dedicated stand for customer display.

Compatibility

Printing

The printing and character specifications are the same as those of the TM-H6000IV. Without special configurations, the TM-H6000V prints the same results as the TM-H6000IV prints.

Print Density

Print density of the TM-H6000V is set in the same way as for the TM-H6000IV by using the software setting mode or by using DIP switches 2-3 and 2-4. You can set the same print density by specifying the same settings as the TM-H6000IV.

Printable Area

The printable area (left/right margins, print start position from the autocutting position, print start position from the manual cutting position) of the TM-H6000V is the same as that of the TM-H6000IV.

Cutting Method

The TM-H6000V uses the partial cutting method (cutting with one point in left edge left uncut) as does the TM-H6000IV.

Receive Buffer

You can specify 4 KB or 45 bytes for the receive buffer of the TM-H6000V in the same manner as the TM-H6000IV by setting DIP switch 1-2. Specify the buffer-full conditions and conditions for clearing the buffer in the same manner as the TM-H6000IV.

Memory Capacity

The sizes of the download buffer and NV graphics data of the TM-H6000V are the same as those of the TM-H6000IV.

Electrical Characteristics

The operating voltage of the TM-H6000V is $DC24 \pm 7\%$, the same as the TM-H6000IV. The current consumption differs, depending on the print duty. When you set the print speed to 350 mm/s, the amount of electricity consumed increases.

DIP Switches

The functional assignments of DIP switches for the TM-H6000V differ from the TM-H6000IV. See "[Setting the DIP Switches](#)" on page 55 for more details.

Printer Status

The TM-H6000V goes to the same status under the same conditions as the TM-H6000IV. You can replace the TM-H6000IV with the TM-H6000V without modifying applications.

Logo Registration

Register logos in the NV memory (NVRAM) of the TM-H6000V by using the setting utility. If logo data registered for the TM-H6000IV has been saved in a computer, you can register the same data in the TM-H6000V.

Driver Compatibility

You can operate the TM-H6000V with a driver for the TM-H6000IV.

USB Low Power Consumption Mode

With the TM-H6000V, you can enable the USB low power consumption mode in the software setting mode.

Maintenance Counter

The TM-H6000V has a maintenance counter just as the TM-H6000IV has.

Overall Dimensions

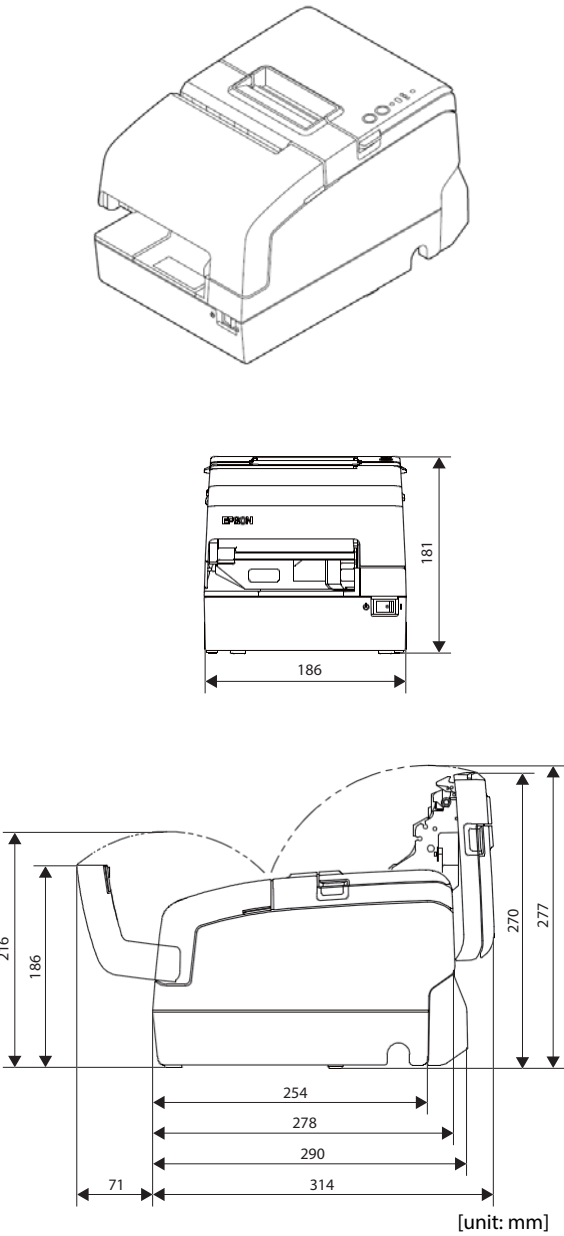
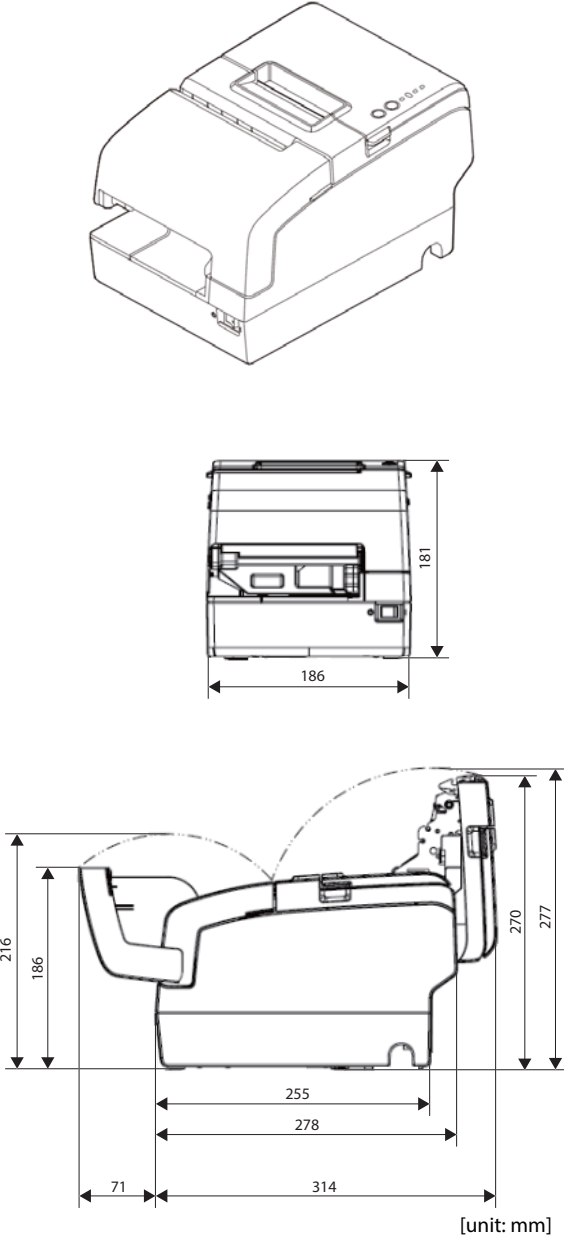
<p>TM-H6000V W:186 × D:278 × H:181 mm Approximately. 4.4kg {W:7.32" × D:10.94" × H:7.13" Approximately. 9.70 lb}</p>	<p>TM-H6000IV W:186 × D:278 × H:181 mm Approximately. 4.4kg {W:7.32" × D:10.94" × H:7.13" Approximately. 9.70 lb}</p>
 <p>Technical drawings of the TM-H6000V device. The top view shows a width of 186 mm. The front view shows a height of 181 mm. The side view shows a total height of 277 mm, with the main body height being 270 mm. Horizontal dimensions from the left edge include 71 mm to the start of the main body, 254 mm to the start of the handle, 278 mm to the end of the handle, 290 mm to the end of the main body, and 314 mm to the end of the device.</p> <p>[unit: mm]</p>	 <p>Technical drawings of the TM-H6000IV device. The top view shows a width of 186 mm. The front view shows a height of 181 mm. The side view shows a total height of 277 mm, with the main body height being 270 mm. Horizontal dimensions from the left edge include 71 mm to the start of the main body, 255 mm to the start of the handle, 278 mm to the end of the handle, 290 mm to the end of the main body, and 314 mm to the end of the device.</p> <p>[unit: mm]</p>

Additional Functions and Functional Improvements

Print Speed

	TM-H6000V	TM-H6000IV
Default	up to 300 or 350 mm/s	up to 300 mm/s
Maximum print speed	up to 350 mm/s *	up to 300 mm/s
Print speed setting (Customized value)	levels 1 to 14	levels 1 to 13

* The values are those when the paper width is set to 80 mm. When it is set to 58 mm, the maximum is 300 mm/s {11.8"/s}.

CAUTION

Depending on print conditions such as print duty, print head temperature, and data transmission speed, print speed is automatically adjusted.

Interface

In addition to a UIB, it is equipped with a standard USB interface and wired LAN interface.

You can also equip with the optional wireless LAN (2.4 and 5 GHz).

You can print from multiple interfaces.

SimpleAP Function

The TM-H6000V comes with a mode (SimpleAP) that allows the printer to connect directly when using an optional wireless LAN unit without having to use a wireless LAN access point.

CAUTION

The SimpleAP function is for making settings only.

NFC

The TM-H6000V is equipped with a built-in NFC tag.

Epson TM Utility for iOS/Android

The TM-H6000V allows you to make a variety of settings using the Epson TM Utility for iOS/Android for smart devices running iOS/Android.

Software Settings

For the TM-H6000V, the following software setting functions are added.

- Default character code table
- Default international character
- Switchover time for a valid interface
- Selection of primary connection interface
- Display when interface is activating
- Column emulation mode
- Auto replacement of receipt font A/ font B/ font C
- Selection of cancellation method for autocutter errors

TM-Intelligent function

The TM-H6000V supports the following TM-Intelligent function.

- Supports Server Direct Print that sends a request for print data from the product to the Web server at regular intervals.

Appendix

Product Specifications

Printing method	Receipt	Thermal line
	Slip/Endorsement ^{*1}	9-pin serial impact dot matrix
Cutting method for receipt		Partial cut (cutting with one point in left edge left uncut)
MICR reader ^{*1}		Permanent magnet
Paper dimensions	Receipt	79.5 ± 0.5 × 83 mm {3.1 ± 0.02 × 3.3"}
	Slip	68 to 230 × 68 to 297 mm {2.7 to 9.1 × 2.7 to 11.7"} (W × L) Minimum size: 68 × 152 mm {2.68 × 5.98"}
Interfaces	USB	× 1 USB 2.0, Full-speed (12 Mbps)
	Ethernet	× 1 10BASE-T/100BASE-TX
	Wireless LAN	IEEE802.11a/b/g/n (2.4 GHz or 5 GHz) Connects an optional Wireless LAN unit to the USB connector.
	Serial ^{*2}	× 1 RS-232
	USB Plus Power ^{*2}	× 1 Full-speed (12 Mbps)
	DM-D	x1 Connect the customer display
	Drawer kick	x1 Connect the cash drawer
Buffers	Receive buffer	4 KB/ 45 bytes Selectable by using the DIP switches.
	Downloaded buffer	12 KB For receipt: 12 KB For slip: 3 KB
	NV graphics data	384 KB
	Downloaded graphics area	208 KB
	User NV memory	1 KB
Barcode ^{*3}		UPC-A, UPC-E, JAN8 / EAN 8, JAN13 / EAN13, Code39, Code93, Code128, ITF, CODABAR (NW-7), GS1-128, GS1 DataBar Omnidirectional, GS1 DataBar Truncated, GS1 DataBar Limited, GS1 DataBar Expanded

Two-dimensional symbol/ Composite symbol printing ^{*4}		PDF417, QR code, MaxiCode, Data Matrix, Aztec Code, GS1 DataBar, Composite Symbology
Inked ribbon	Slip	ERC-32
	Endorsement ^{*1}	ERC-43
Supplied voltage		DC 24 V \pm 7%
Current consumption		Mean: Approximately. 1.8 A
AC power consumption ^{*5} (100 V to 230 V, 50 to 60 Hz)		Operating: Approximately. 33.8 W Standby: Approximately. 0.82 W
Life	Mechanism	20 million lines
	Thermal head	200 km (when using the specified original paper types (PD160R, TF50KS-EY, or KT55FA))
	Autocutter	3 million cuts (when using the specified original paper types (PD160R, TF50KS-EY, or KT55FA), at normal temperature and normal humidity)
	MTBF	360,000 hours
	MCBF	70 million lines
Temperature/humidity		Operating: 5 to 45°C {41 to 113°F} Storage: -10 to 50°C {14 to 122°F}
Humidity		Operating: 10 to 90% RH Storage: 10 to 90% RH, except for paper
Air pressure (Altitude)		726 hPa (Approximately. 3000 m {3280.84 yards} above sea level) or less
Overall dimensions		181 × 186 × 278 mm {7.13 × 7.32 × 10.94"} (H × W × D)
Mass		Approximately. 4.4 kg {9.7 lb} (paper excluded)

* 1: Factory installed options.

* 2: The available interfaces vary by the printer model.

* 3: Only picket fence bar codes are supported if using a slip printer.

* 4: Cannot be printed by using the slip printer.

* 5: This is the average power under our operation conditions. It varies depending on the conditions of use and the model.

Printing Specifications

Slip printing

Printing method		Serial impact dot matrix
Head wire configuration		9-pin vertical line, wire pitch approximately 0.353 mm {1/72"}
Printing direction		Bidirectional, minimum distance printing
Printing speed *	Front	Approximately. 5.7 lps (printing 40 columns per line with 17.8 cpi)
	Endorsement	Approximately. 4.0 lps (printing 40 columns per line with 21.2 cpi)
Characters per line	Front	Font A (initial setting): 45 Font B: 60
	Endorsement	Font A: 25 Font B: 33 Endorsement font (initial setting): 40
Character dot spacing	Front	Font A (initial setting): 1 dot Font B: 2 half dots
	Endorsement	Font A: 1 dot Font B: 2 half dots

lps: lines per second

cpi: characters per inch

* when the head energizing time is set to normal mode.

NOTE

Printing speed may be slower, depending on such items as the data transmission speed.

Receipt printing

Printing method	Thermal line printing
Dot density	180 × 180 dpi
Printing direction	Unidirectional with friction feed
Maximum print speed *	Paper width setting 80 mm: 350 mm/s {13.78"/s} (at DC 24 V, 25 °C, Print density 100%)
Printing width	72.0 mm {2.83"}, 512 dots
Characters per line	Font A (initial setting): 42 Font B: 56 Font C: 51
Feeding pitch	0.1411 mm
Paper feed speed	Approximately, 200 mm/s {7.87"/s} (during continuous printing)
Line spacing	Approximately, 4.23 mm {1/6"}

NOTE

* Text printing (built-in fonts), page mode, and monochrome graphics printing.

- The print speed changes automatically depending on the voltage applied to the printer and the condition of the head temperature.
- Maximum print speed may not be achieved depending on the type of interface, data transmission conditions and combination of commands.
- If the print speed fluctuates or intermittent printing occurs due to the data transmission conditions, printing may be shaded or white lines may occur.
- Low transmission speed may cause intermittent printing, especially when using a serial interface. It is recommended to transmit data to the printer as quickly as possible.
- The following conditions specify the maximum print speed regardless of the print density and paper width settings.
 - * The maximum is 100 mm/s {3.94"/s} when printing ladder barcodes or two-dimensional symbols.
 - * The maximum is 150 mm/s {5.91"/s} when printing multi-tone graphics (NV download graphics).
 - * The maximum is 70 mm/s {2.76"/s} when printing multi-tone graphics (raster graphics).

CAUTION

- When changing the paper width, you need to install the optional 58 mm paper guide (PG-58II) and to change the setting for the paper width with the customized value. To change the paper width, see "[Software Settings](#)" on page 60.
- Because some parts of the print head and the autocutter contact the platen and they may become worn out in 58 mm printing, once you change the paper width from 80 mm to 58 mm, you cannot change it back to 80 mm.

Character Specifications

Slip printing

Number of characters		Alphanumeric characters: 95 Extended graphics: 128 × 12 pages (including user-defined page) International characters: 18 character types
Character structure (W × H dots)	Font A	5 × 9 dots
	Font B	7 × 9 dots
	Endorsement font	5 × 7 dots
Character size (W × H)	Font A	1.56 × 3.11 mm
	Font B	1.24 × 3.11 mm
	Endorsement font	1.09 × 2.41 mm

Receipt printing

Number of characters		Alphanumeric characters: 95 Extended graphics: 128 × 12 pages (including user-defined page) International characters: 18 character types
Character structure (W × H dots)	Font A	12 × 24 dots (including 2-dot horizontal spacing)
	Font B	9 × 17 dots (including 2-dot horizontal spacing)
	Font C	10 × 20 dots (including 1-dot horizontal spacing)
Character size (W × H)	Font A	Standard: 1.41 × 3.39 mm Double-height: 1.41 × 6.77 mm Double-width: 2.82 × 3.39 mm Double-width, double-height: 2.82 × 6.77 mm
	Font B	Standard: 0.99 × 2.40 mm Double-height: 0.99 × 4.80 mm Double-width: 1.98 × 2.40 mm Double-width, double-height: 1.98 × 4.80 mm
	Font C	1.27 × 2.82 mm

NOTE

- Space between characters is not included.
- Characters can be scaled up to 64 times as large as the standard size.

Paper Specifications

Slip printing

Types		Normal paper, pressure sensitive paper, carbon copy paper
Form		Slip paper
Size (W × L)		68 to 230 mm × 68 to 297 mm {2.68 to 9.06" × 2.68 to 11.69"} The minimum size is 68 × 152 mm {2.68 × 5.98"}.
Thickness	Normal paper (singleply)	0.09 to 0.22 mm {0.0035 to 0.0087"}
	Copy paper (front)	Backing paper: 0.07 to 0.12 mm {0.0028 to 0.0047"} Copy paper, original paper: 0.04 to 0.07 mm {0.0016 to 0.0028"} Carbon copy paper: Approximately. 0.035 mm {0.0014"} Total thickness: 0.09 to 0.47 mm {0.0035 to 0.0185"}
	Copy paper (endorsement)	Backing paper: 0.07 to 0.12 mm {0.0028 to 0.0047"} Copy paper, original paper: 0.04 to 0.07 mm {0.0016 to 0.0028"} Copy carbon paper: Approximately. 0.035 mm {0.0014"} Total thickness: 0.09 to 0.31 mm {0.0035 to 0.0122"}

CAUTION

- Copy capability is greatly influenced by the ambient temperature, so printing must be performed under the conditions described below.

	Number of copies	Total thickness	Ambient temperature
Copy paper (front)	original + 3 copies	0.31 mm or less	10 to 40°C {50 to 104°F}
	original + 2 copies	0.31 mm or less	5 to 45°C {41 to 113°F}
	original + 2 copies	0.47 mm or less	10 to 40°C {50 to 104°F}
Copy paper (endorsement)	original + 3 copies	0.31 mm or less	10 to 40°C {50 to 104°F}

- The slip paper must be flat and without curls, folds (especially curls or folds at the top edges), curves, or wrinkles. Otherwise, it may rub against the ink ribbon and become dirty.
- The slip holding roller may make marks on the copy paper.
- Print position may shift for the top and bottom sheets of multi-ply paper; therefore, when formatting slip paper, take this into account.
- Use thinner paper (N30 or equivalent) between the top and bottom sheets of multi-ply paper. If thick paper is used, the copy capability is lowered.
- The slip paper must be flat, without curls or wrinkles, especially at the top edges.

CAUTION

- Choose slip paper carefully when using slip paper with glued area, since printing, paper feeding, and insertion are affected by gluing conditions (e.g. quality, method, and length of glue) and glue location. Be especially careful when slip paper is wide and has the glue on the left edge, since drifting may occur.

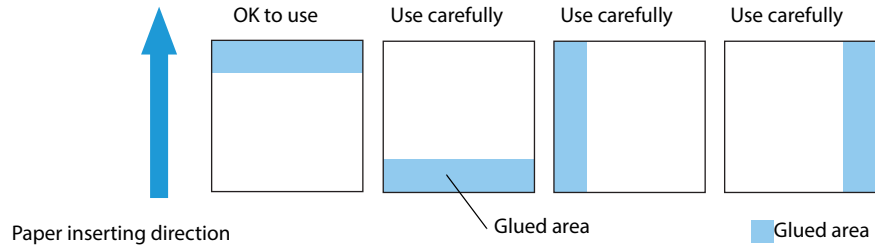

- Use thinner paper (N30 or equivalent) between the top and bottom sheets of multi-ply paper. If thick paper is used, the copy capability is lowered.
- Do not use paper that has holes, or is translucent at the BOF sensor position.
- Do not use paper that has holes or dark positions with low reflection (less than 40% reflection) on the front at the TOF sensor position.

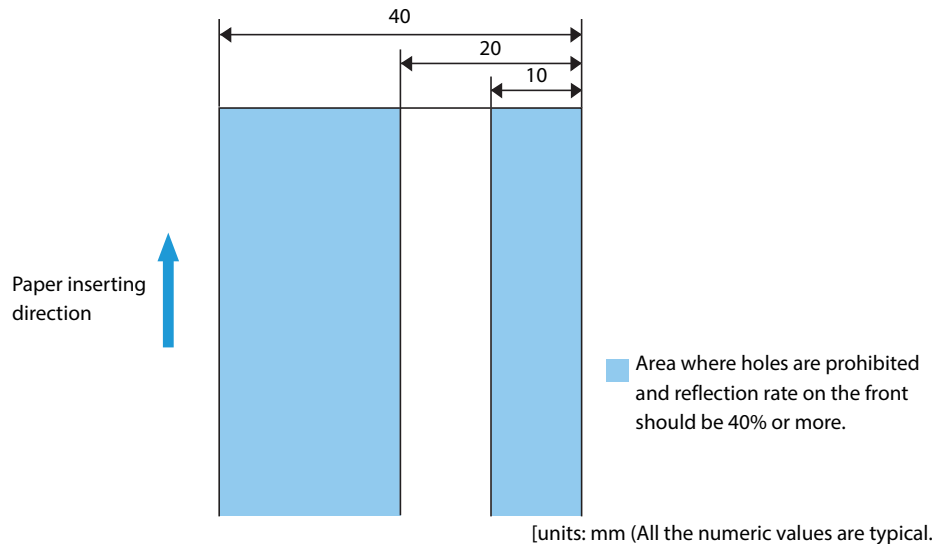

Do not use paper that has holes or dark positions with low reflection (less than 40% reflection) on the back at the validation sensor (only for the validation models).

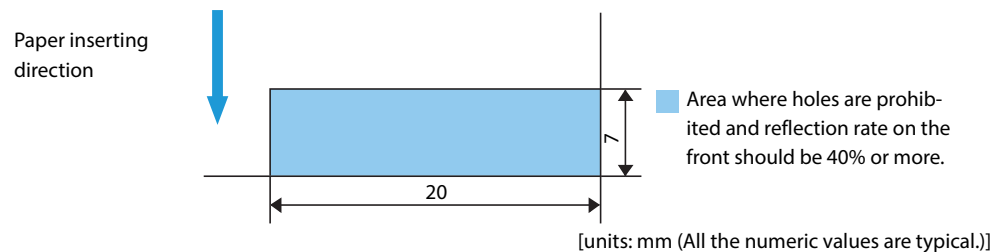

Receipt printing

Type	Thermal paper	
Form	Roll paper	
Size	Roll paper diameter	83 mm {3.27"} maximum
	Roll paper spool	Inside: 12 mm {0.47"}, Outside: 18 mm {0.71"}
	Roll paper core width	Same as the roll paper width, or smaller than the paper width by 1 mm {0.04"} or less.
	Roll width when taken up	80+0.5/-1.0 mm
	Paper width	79.5 ± 0.5 mm
Specified roll paper type	TF50KS-EY, TF60KS-EY, PD160R, PD190R, P220AGB-1, AF50KS-E, F5041(55), F5041(48), KT55FA?KT48FA, P30521, P30523, P31523, P35524	
Paper thickness	Maximum of 80 µm, minimum of 48 µm	

CAUTION

- Paper must not be pasted to the roll paper spool.
For the best print quality for each paper type, it is recommended to test the print density.
(See ["Software Settings" on page 60.](#))

Print density adjustment depending on the specified original paper

- In order to ensure optimal print quality and reliability, we recommend using the print density settings in the table below. The print density can be changed by using the DIP switches and customized values.

Specified original paper and recommended print density setting (DIP switches)

Specified original paper	Print density
TF50KS-EY, TF60KS-EY, PD160R, PD190R, P220AGB-1 AF50KS-E, KT55FA, KT48FA	Standard
F5041(55), F5041(48), P30521, P30523, P31523, P35524	Medium

Specified original paper and recommended print density setting (customized values)

Specified original paper	Print density	Print speed
AF50KS-E	4 (85%)	13 (300 mm/sec)
P220AGB-1	5 (90%)	13 (300 mm/sec)
TF50KS-EY	5 (90%)	14 (350 mm/sec)
P35524	6 (95%)	13 (300 mm/sec)
PD160R, KT55FA	7 (100%)	14 (350 mm/sec)
TF60KS-EY, PD190R, KT48FA, F5041(55), F5041(48)	7 (100%)	13 (300 mm/sec)
P30521, P30523, P31523	8 (105%)	13 (300 mm/sec)

- The initial setting is 100% print density.
- If setting the speed to 350 mm/sec, use a customized value to set the print density to the recommended setting.
- When the print density setting is too dark, the print speed tends to drop. If the print density is 115% or higher, and the room temperature is 15°C {59°F} or lower, the speed will be 200 mm/sec or slower.
- When the print density setting is too dark, paper dust sticks to the print head surface, often resulting in faded print.

Notes on preprinting

- Preprinted thermal paper may cause faulty printing and decreased print density due to the thermal head sticking to the recording surface. Therefore, it is preferable to avoid using preprinted thermal paper.
- If using preprinted thermal paper, make sure in advance that the conditions recommended by the original paper manufacturing company (type of ink, print conditions, etc.) are met, and that there is no faulty printing or decreased print density in the actual usage environment.

Printable Area

Slip (front) printing

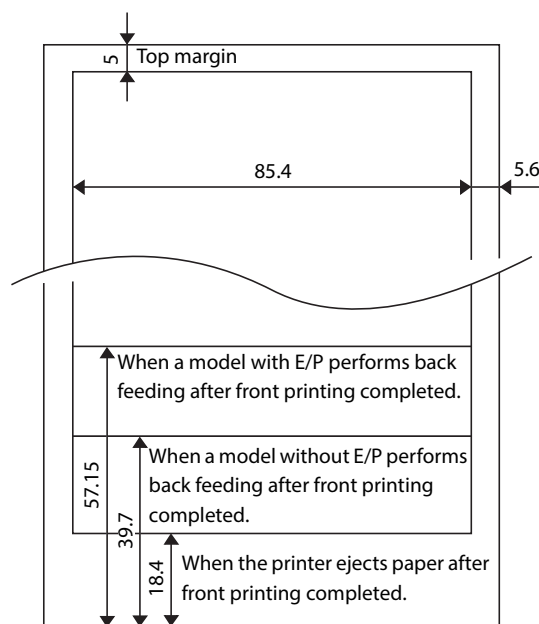

[units: mm (All the numeric values are typical.)]

Slip (endorsement) printing

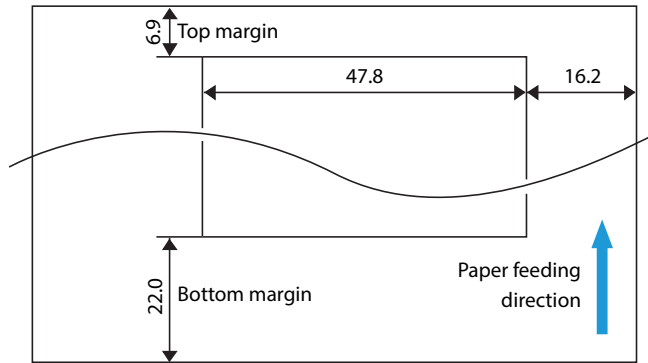

[units: mm (All the numeric values are typical.)]

Slip (validation) printing

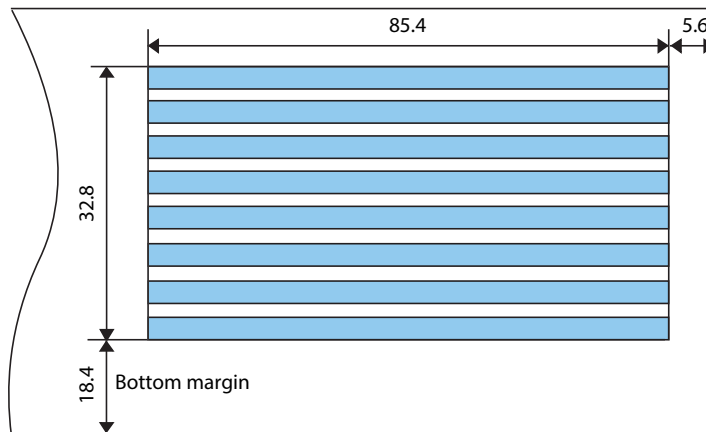

[units: mm (All the numeric values are typical.)]

Receipt printing

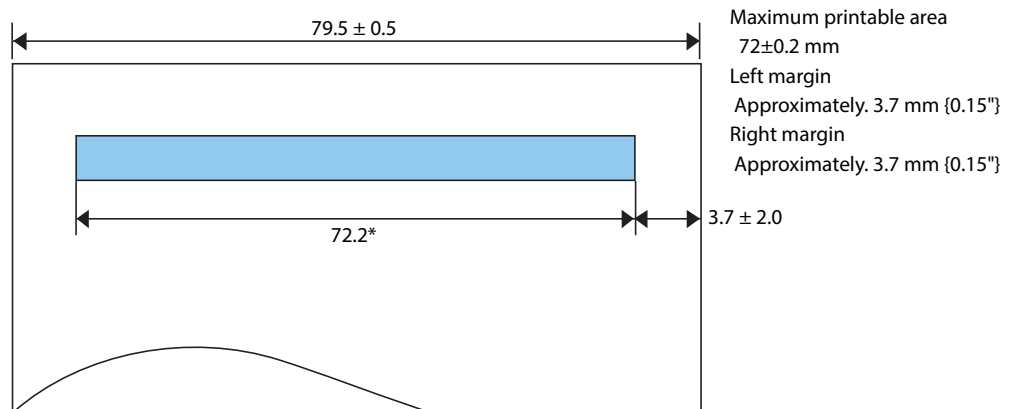

[units: mm (All the numeric values are typical.)]

Printing and Cutting Positions

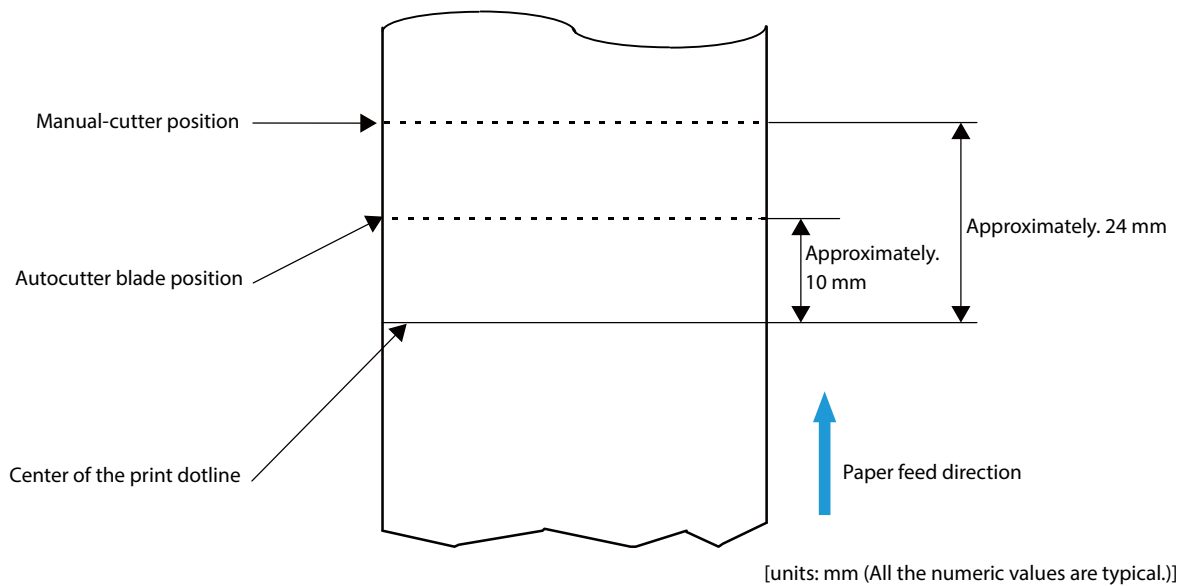

CAUTION

- The values above may vary slightly as a result of paper slack or variations in the paper.
- Take this into account when setting the cutting position of the autocutter.

NOTE

- The cut paper may be pulled at the cut edge when it is removed, causing reduced printing pitch for the first line of the next receipt. To prevent dot displacement, after cutting, feed the paper approximately 1 mm {14/360"} or more before the first line of printing.
- A paper jam may occur inside the autocutter if the printer is left unused for a long time with paper left loaded in the printer. When operating the autocutter after leaving the printer unused for a long time, feed paper of 40 mm {1.57"} or longer before operating the autocutter to prevent paper jams.

Ribbon Cassette

Model		Slip printing (front): ERC-32 Endorsement printing: ERC-43
Color		Black
Life *	ERC-32	4,000,000 characters
	ERC-43	3,000,000 characters

* at 25°C {77°F} with continuous printing

Notes on using the endorsement printer

You can use an endorsement printer to perform MICR reading and endorsement printing without turning over the check. For this reason, be careful of the following points regarding the endorsement printer when developing an application.

- When endorsement printing is executed after MICR reading, the printer automatically feeds the paper forward after receiving a command to print the endorsement. Next, the printer starts printing from the print starting position (approximately 6.9 mm {0.27"} from the end of the check) by using reverse paper feeding.
- Since the endorsement printing format assumes a sequence appropriate for printing of an endorsement on a US personal check, printing begins at the far end from the inserted side of the check with the print turned upright. (The endorsement characters are printed upside-down as viewed from the front of the printer.)
- In some cases paper feeding may not be accurate when endorsement printing is performed on a check depending on the width of the check. We recommended that you check in advance whether printing is performed correctly on the check you want to use.

MICR Reader (Factory-Installed Option)

Reading method	Magnetic bias
Supported fonts	E13B, CMC7 (Alphabets are not supported.)
Recognition rate*	Recognition rate: 99% or more Recognition error rate: 0.1% or less

* When using ANSI/ISO specified paper at 25°C {77°F}

Recognition rate (%) =

{Total number of checks-(number of checks misread or not recognized)}/Total number of checks × 100

Inserting direction and endorsement/face printing

Securely insert the check with the surface printed with magnetic ink facing upward along the slip side guide.

- The printer can perform check reading followed by endorsement/face printing.

Area of MICR Recognition

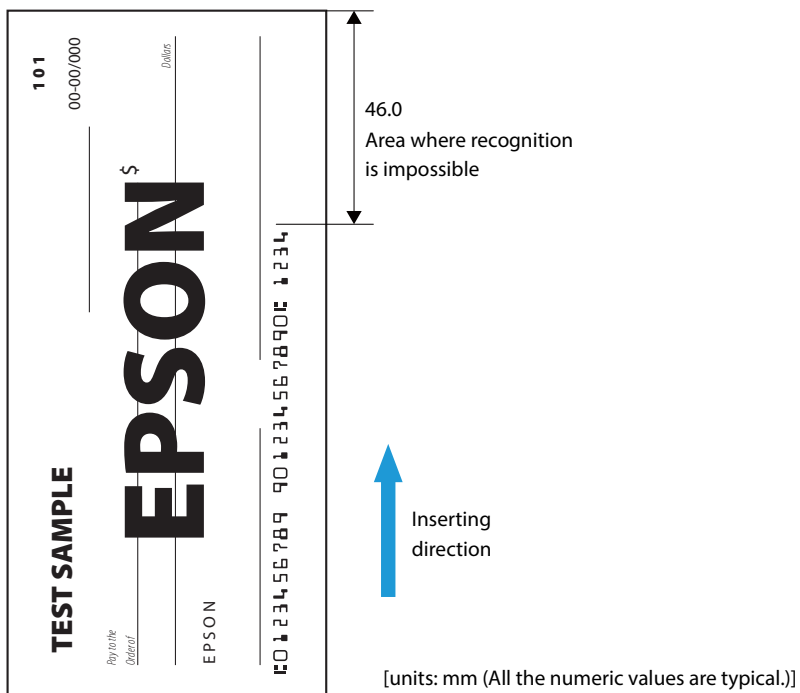

Area Specified for Endorsement

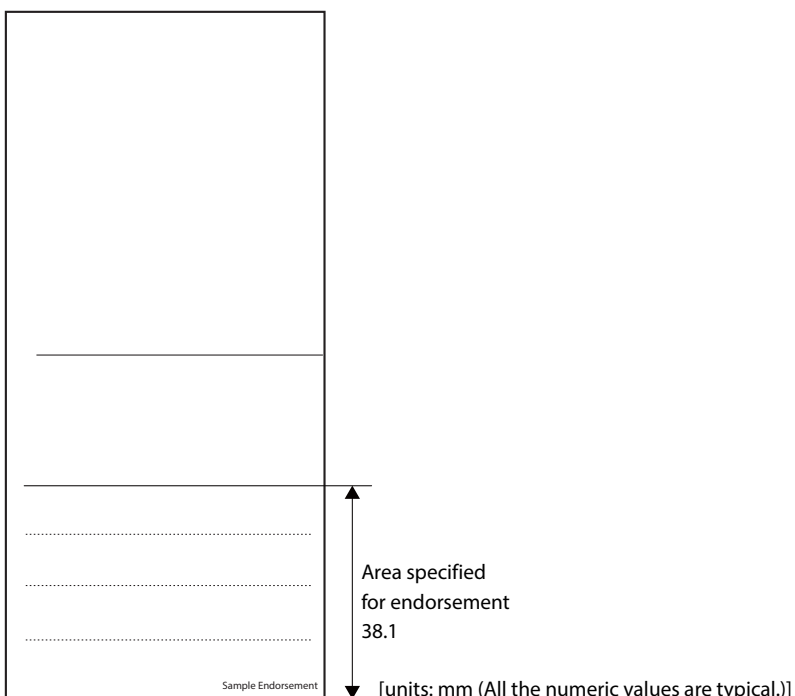

Notes on using the MICR reader

- For MICR reading, the minimum length of paper is 120 mm {4.72"}.
- The check paper must be flat and without curls, folds (especially curls or folds at the top edges), curves, or wrinkles. Otherwise, it may rub against the ink ribbon and become dirty.
- Do not insert checks that have clips, staples, or similar foreign material attached. This may cause paper jams, MICR reading errors, or damage to the MICR head.
- Let go of the check immediately as soon as the printer starts feeding it. Not letting go of the check can cause it to be fed at an angle, resulting in meandering, paper jams or MICR reading errors.
- The MICR characters may not be recognized if the printer is subject to impact or vibration.
- If the printer is installed near any magnetic fields, to prevent false recognition of the MICR caused by the magnetic fields, MICR reading operation may stop and MICR reading errors may occur. In such cases, install the printer away from the devices, or install materials that can prevent electromagnetic waves, such as a steel plate or shielding material, between the printer and electric equipment in order to decrease the negative effects of electromagnetic waves from electronic devices and so that the MICR can operate normally. (Be especially sure to check the MICR recognition rate when the printer is used near a display device.)

Barcode/ Two-dimensional symbol/composite symbol

Barcode/two-dimensional symbol Print Direction

Barcode/two-dimensional symbol print direction and name are as follows.

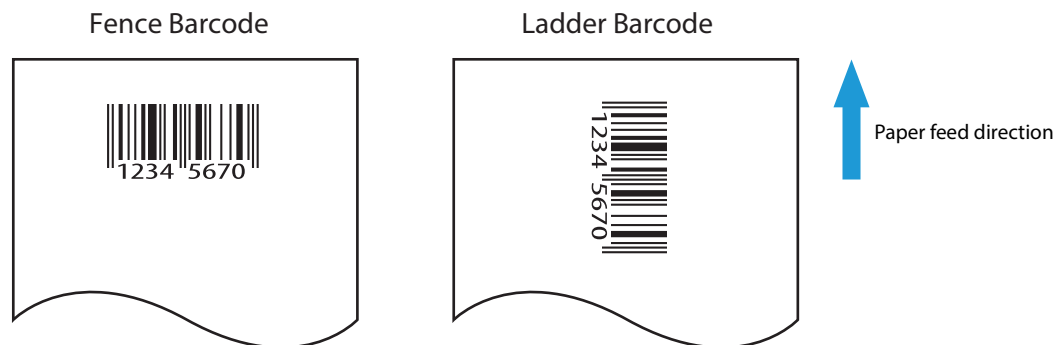

Notes on printing barcodes and 2-dimensional symbols

- Set the quiet zone according to the bar code standards.
- When printing PDF417 (2-dimensional symbols), it is recommended to set the height of one step of the symbol to three to five times the width of one module, and the total height of code should be approximately 5 mm {0.20"} or more.
- The recognition rate of ladder barcodes and 2-dimensional symbols may vary depending on widths of the modules, print density, environmental temperature, type of roll paper (thermal paper), and characteristics of the reader. Therefore, you must check the recognition rate before setting the use conditions so that the restrictions of the reader are satisfied.
- Reading quality of barcodes/2-dimensional symbols in multi-tone graphics printing is not guaranteed.
- When printing ladder barcodes/2-dimensional symbols with graphics printing, set the print speed to speed level 4 instead of using the barcodes/2-dimensional symbols print commands.
See "[Software Settings](#)" on page 60.
- Note the following when printing barcodes on the face of a slip:
 - Ladder barcodes and 2-dimensional symbols are not supported.
 - Be sure to add HRI characters because the recognized rate of barcode reading may vary depending on density, gradation, or performance capabilities of barcode reader used.

Electrical Characteristics

Supply voltage		DC 24V ± 7%	
Current consumption (when using the PS-180 at 24V)	Standby	Mean: Approximately. 0.1 A	
	Operating	Slip printing	Mean: Approximately. 1.7 A
		Receipt printing	Mean: Approximately. 1.8 A Note: When print ratio is approximately 18% <ul style="list-style-type: none"> • Continuous printing for 30 lines (repeating 20H-7FH) * Font A, 42 columns, ASCII character • 5 line feeding • Autocutting

If printing is continuously performed with a high ratio, the overcurrent protection may be activated and result in uneven print density or a low voltage error. Therefore, the printing length must not exceed the following values when printing with high print ratio.
 Print ratio: Number of dots being energized per one dot line/Total number of dots per one dot line (512 dots)

Print ratio	80%	100%
Print example		
Print length	30 mm	20 mm

Reliability

Life	Slip printer section/ Endorsement printer section	Number of carriage driving times	12,000,000 times for each section
		Number of paper feeds	Total for the sections: 27,000,000 lines
		Print head	200 million characters (when printing with Font B only)
	Receipt printer section	Printer mechanism	20,000,000 lines (when repeatedly printing 10 lines with 4.23 mm line spacing and feeding 5 lines)
		Print head	200 km
		Autocutter	3,000,000 cuts (when using the specified original paper types, TF50KS-EY, PD160R, KT55FA)
	MICR reader mechanism (factory-installed option)		240,000 passes (for US personal checks)
MTBF	Slip printer section/ Endorsement printer section		180,000 hours
	Receipt printer section		360,000 hours
MCBF	Slip printer section/ Endorsement printer section	Number of carriage driving times	29,000,000 times for each section
		Number of paper feeds	Total for the sections: 65,000,000 lines
	Receipt printer section		96,000,000 lines

Environmental Conditions

Temperature/ Humidity	Operating	5 to 45°C {41 to 113°F}, 10 to 90% RH
	Storage	-10 to 50°C {14 to 122°F}, 10 to 90% RH (except for paper and ink ribbon cartridges)
		<p>Operating environment range</p> <p>Specified original paper: P30023, P31023, P35023</p> <p>Specified original paper other than above</p>
Acoustic noise (operating, receipt printer section)		<p>Approximately. 55 dB (bystander position) (including autocutting operation)</p> <p>Note:</p> <p>The values above are measured in the Epson evaluation condition.</p> <p>Acoustic noise differs depending on the paper used, printing contents, and the setting values, such as print speed or print density.</p>

External Dimensions and Mass

The external dimensions and mass of the standard model (with MICR reader and endorsement printer)

- Height: Approximately 181 mm {7.13"}
- Width: Approximately 186 mm {7.32"}
- Depth: Approximately 278 mm {10.94"} (excluding the connector cover)
- Mass: Approximately 4.4 kg

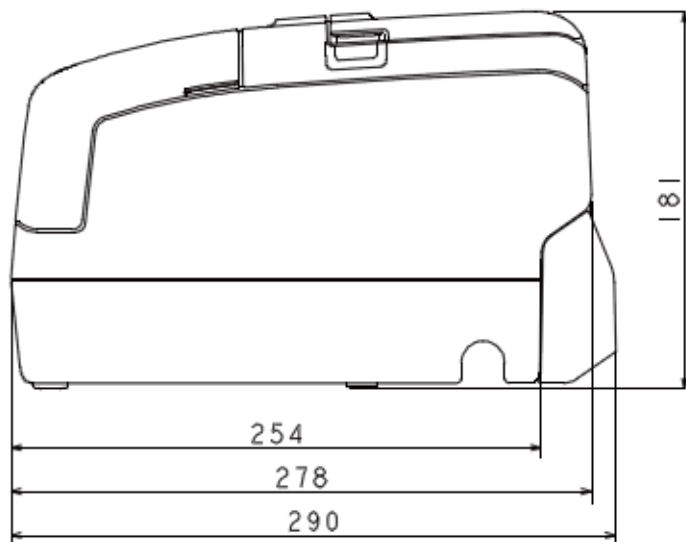
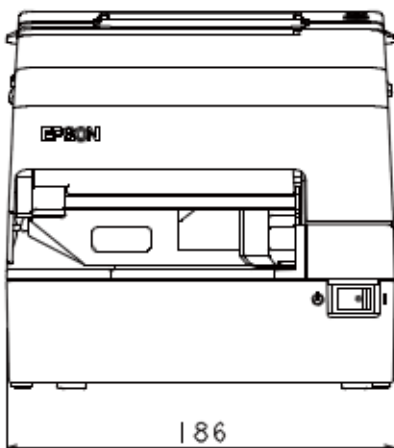
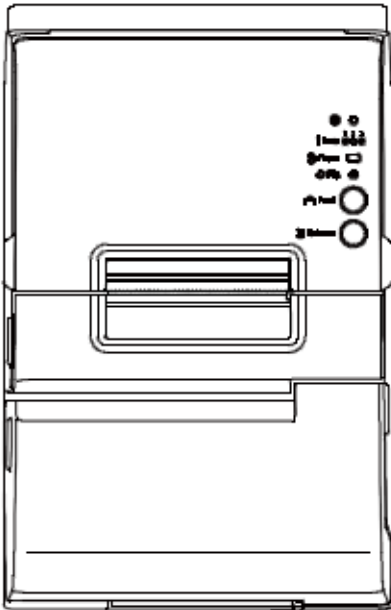

[units: mm (All the numeric values are typical.)]

Bluetooth Low Energy Technology Advertising

Introduction

When you connect the BT820 from Laird Tech to the USB A connector on the TM-H6000V and turn it on, the *Bluetooth* low energy technology Advertising Packet is transmitted. By default, the TM-H6000V transmits the packet according to the iBeacon Format from Apple. You can also change the data that is transmitted by following the steps in "[Changing the Bluetooth Low Energy Technology Advertising Packet](#)" on page 147.

Glossary:

Term	Description
<i>Bluetooth</i> Low Energy Technology Advertising	The name of this function.
<i>Bluetooth</i> Low Energy Technology Advertising Packet	The data sent by this function from the printer.
<i>Bluetooth</i> adapter	The BT820 from Laird Tech A USB dongle to connect to the USB Type A connector.
iBeacon	The format stipulated by Apple for <i>Bluetooth</i> low energy technology Advertising Packets When using the default settings for the TM-H6000V (<i>Bluetooth</i> adapter installed in the printer and the printer is on), the <i>Bluetooth</i> low energy technology Advertising Packet is transmitted in iBeacon format.

Dongle specifications

Manufacturer: Laird Tech

Model name: BT-820

For setting, use the Epson TM Utility for iOS.

Procedure

When turning on the TM-H6000V, the *Bluetooth* adapter connected to the USB Type A connector is enabled. If you install the *Bluetooth* adapter after turning on the printer, this is not enabled.

Bluetooth Low Energy Technology Advertising Packet Format

In the TM-H6000V, the iBeacon format is used by default for the *Bluetooth* low energy technology Advertising Packet.

The UUID for the TM-H6000V is "fac1ba2f-61a2-4d83-9a8c-60087c232569".

The user can edit the following specifications in the iBeacon format: UUID, Major number, Minor number, and Measured Power.

Table 1 iBeacon Packet Format

Content	Data Length	Value	Description
Length of this data	1 byte	02h	
AD type	1 byte	01h	Adtype: flags
Flags	1 byte	06h	Fixed value (06h)
Length of this data	1 byte	1Ah	Fixed value (1Ah)
AD type	1 byte	FFh	Adtype: Company identifier
Company Identifier code	2 bytes	004Ch	Apple's manufacture ID
iBeacon type	1 byte	02h	Incomplete List of 16-bit service UUIDs
iBeacon length	1 byte	15h	15h=21=16+2+2+1
UUID	16 bytes	-	Default UUID = fac1ba2f-61a2-4d83-9a8c-60087c232569
Major Number	2 bytes	-	
Minor Number	2 bytes	-	
Measured Power	1 byte	C7h	C7h (-57 dB)

Changing the *Bluetooth* Low Energy Technology Advertising Packet

The TM-H6000V can acquire a configuration script from the printer.

You can also change settings by transmitting the configuration script to the printer.

The configuration script only supports UTF-8 encoding.

The iBeacon Format is defined in the configuration script by default for the TM-H6000V.

You can change this Packet Format to support Eddystone-UID or Eddystone-URL.

However, the TM-H6000V only supports single Advertising Data Packets.

You can change the settings using either of the following two methods.

- Changing settings using the Epson TM Utility for iOS
- Changing settings using an HTTP Request

The method of changing settings via an HTTP Request is explained below.

Digest authentication

You need Digest authentication to communicate with the printer.

The default ID and Password are ID: epson, Pass: epson and are the same as the administrator for Network settings.

Escape processing for configuration scripts

When reading/writing a configuration script for a printer, the strings (content of the configuration script) being transmitted and received uses the following escape processing. However, escape is not performed for uXXXX (hexadecimal strings) such as Japanese.

Table 2 Escape Processing

Escape	Description
\"	quotation mark
\\	reverse solidus
\b	backspace
\f	form feed
\n	line feed
\r	carriage return
\t	tab
\u002F	solidus
\u003C	<
\u003E	>
\u002B	+

Acquiring the configuration script from the printer using an HTTP request

A response for the json format is acquired using the GET method for the HTTP request.

Request

Table 3 Request Header

Request header: Content-Type: text/plain; charset=utf-8 http://(printer IP address)/webconfig/beacon.cgi?Type=(one of the following Table 4 Types)

Table 4 Types

Type	Description
(none)	If a Type is left out, the same operation is performed as when current is specified.
current	Specifies the currently enabled configuration script.
volatile	Specifies the configuration script stored in RAM.
static	Specifies the configuration script stored in ROM.
default	Specifies the default configuration script.
status	Acquires information for the <i>Bluetooth</i> adapter.

Response

Table 5 Response Header

Content-Type: application/json; charset=utf-8 Access-Control-Allow-Origin: * Access-Control-Allow-Methods: POST, GET, OPTIONS, HEADER Access-Control-Allow-Headers: Content-Type, Content-Length, Authorization X-Content-Type-Options: nosniff X-XSS-protection: 1; mode=block X-Frame-Options: deny Content-Security-Policy: default-src 'none' WWW-Authenticate: Digest realm="<IPaddr>", nonce="xx", qop="auth"

Table 6 Response

Function	GET Parameter	Results	Response
Acquires the configuration script currently enabled	Type=current Or no Type is set	Acquisition successful	200 OK
Acquires the configuration script on the RAM	Type=volatile	Acquisition successful	200 OK
		Acquisition failed (No file)	404 Not Found
Acquires the configuration script on the ROM	Type=static	Acquisition successful	200 OK
		Acquisition failed (No file)	404 Not Found
Acquires the Default configuration script	Type=default	Acquisition successful	200 OK
Acquires information from the <i>Bluetooth</i> adapter	Type=status	Acquisition successful	200 OK
		Acquisition failed (No adapter connected)	404 Not Found
Others	Type = Other than the above or A parameter except for Type exists	Type is invalid	400 Bad Request

Table 7 GET Response Body

Response Status	Response Body
200 OK	{ "message": "Success" "detail": null "description": <Encoded string for the configuration script> }
404 Not Found	"message": "Requested file not found" "detail": null "description": null }
400 Bad Request	{ "message": "Invalid Parameter" "detail": null "description": null }

Table 8 GET Response Body (Type=status)

Response Status	Response Body
200 OK The HCI Version for the <i>Bluetooth</i> adapter is 6 or higher Link	{ "message": "Success", "detail": null, "description": { "VendorID": "0a12", "ProductID": "0001", "ProductName": "CSR8510 A10", "Bluetooth LE": "Support" } }
200 OK The HCI Version for the <i>Bluetooth</i> adapter is 5 or lower	{ "message": "Success", "detail": null, "description": { "VendorID": "0a12", "ProductID": "0001", "ProductName": "(no name)", "Bluetooth LE": "Not support" } }
404 Not Found Adapter not connected	"message": "Beacon dongle not connected", "detail": null, "description": null }

Writing the configuration script to the printer

You can save a configuration script to the printer using the HTTP POST method.

You can save the configuration script to volatile or non-volatile memory.

When changing using a low frequency less than once an hour, you can save to non-volatile memory; however, when changing at a higher frequency, you need to save to volatile memory.

When the change is successful, the advertising data is changed.

Request

```
Content-Type: text/json; charset=utf-8
http://(printer IP address)/webconfig/beacon.cgi
```

See the POST parameters in Table 10 Response for the parameters.

Response

Table 9 Response Header

```
Content-Type: application/json; charset=utf-8
Access-Control-Allow-Origin: *
Access-Control-Allow-Methods: POST, GET, OPTIONS, HEADER
Access-Control-Allow-Headers: Content-Type, Content-Length, Authorization
X-Content-Type-Options: nosniff
X-XSS-protection: 1; mode=block
X-Frame-Options: deny
Content-Security-Policy: default-src 'none'
X-RateLimit-Limit: 1 (when type=static only)
X-RateLimit-Remaining: 1 or 0 (when type=static only)
X-RateLimit-Reset: 1390941626 (when type=static only)
WWW-Authenticate: Digest realm="<IPAddr>", nonce="xxxxxxxxxxxxxxxxxxxxxxxxxxxxxxxxxxxxxxxx", qop="auth"
```

Table 10 Response

Function	POST Parameters	Results	Response
Updating the configuration script in volatile memory	<pre>{ "type": "volatile", "description": "<The string for the configuration script that performed escape processing>" }</pre>	Update successful	200 OK
		Update failed	413 Request Entity Too Large
		When the parameter is too long	
Deletes the configuration script from volatile memory	<pre>{ "type": "volatile", "description": "delete" }</pre>	Update failed	500 Internal Server Error
		When an error occurs when applying a new configuration script	
Deletes the configuration script from volatile memory	<pre>{ "type": "volatile", "description": "delete" }</pre>	Deleting successful	200 OK
		Deleting failed	500 Internal Server Error

Function	POST Parameters	Results	Response
Updates the configuration script in non-volatile memory	<pre>{ "type": "static", "description": "<The string for the configuration script that performed escape processing>" }</pre>	Update successful	200 OK It has following header: X-RateLimit-Limit: 1 X-RateLimit-Remaining: 0 X-RateLimit-Reset: xx
		Update failed When the parameter is too long	413 Request Entity Too Large It has following header: X-RateLimit-Limit: 1 X-RateLimit-Remaining: 1 X-RateLimit-Reset: xx
		Update failed When an error occurs when applying a new configuration script	500 Internal Server Error It has following header: X-RateLimit-Limit: 1 X-RateLimit-Remaining: 0 X-RateLimit-Reset: xx
		Update failed When the gap between updating is more than once an hour	429 Too Many Requests It has following header: X-RateLimit-Limit: 1 X-RateLimit-Remaining: 0 X-RateLimit-Reset: xx
Deletes the configuration script from non-volatile memory	<pre>{ "type": "static", "description": "delete" }</pre>	Deleting successful	200 OK
		Deleting failed	500 Internal Server Error
Others	<ul style="list-style-type: none"> • No parameters • Invalid parameters • Error in escape processing 	Update failed	400 Bad Request

Table 11 POST Response Body

Response Status	Body
200 OK	{ "message": "Success", "detail": null, "description": < The string for the configuration script that performed escape processing > }
400 Bad Request	{ "message": "Invalid Parameter", "detail": "****", (see Table 12) "description": null }
413 Request Entity Too Large	{ "message": "Request Entity Too Large", "detail": null, "description": null }
429 Too Many Requests	{ "message": "You sent too many requests in a given amount of time.", "detail": null, "description": null }
500 Internal Server Error	{ "message": "Failed to update settings", "detail": "****", (see Table 13) "description": null }

Table 12 400 Bad Request Details

Case	Body
The correct escape processing is not performed at the point escape processing is needed	{ "message": "Invalid Parameter", "detail": "Special characters must be escaped", "description": null }
An undefined Type parameter has been specified	{ "message": "Invalid Parameter", "detail": "A parameter 'type' is invalid", "description": null }

Case	Body
No Type specified Or an invalid parameter has been specified	{ "message": " Invalid Parameter ", "detail": "A parameter 'type' or 'description' is not specified", "description": null }
When detecting a string with invalid escape processing	{ "message": " Invalid Parameter ", "detail": "Invalid parameter is found", "description": null }

Table 13 500 Internal Server Error Details

Case	Body
Update failed	{ "message": "Failed to update settings", "detail": null, "description": null }
Deleting failed	{ "message": "Failed to delete settings", "detail": null, "description": null }
An error occurs when applying a new configuration script	{ "message": " Failed to set the settings to the beacon.", "detail": <Error code from BeaconCtrl> "description": null }

Editing the Configuration Script

In the configuration script, the settings for the module for *Bluetooth* in Linux can be written in the same way as for the Bluez hcitool, and you can customize the settings.

Make sure you include the following descriptors in the configuration script.

- Advertising stop
- Device address specifications
- Advertising parameter specifications
- Advertising start
- Advertising data specifications

Starting and stopping *Bluetooth* low energy technology Advertising

Format: cmd 0x08 0x000A n

Function: Starting and stopping transmission of the Advertising packet.

Parameter n	Length	Function
00	2 characters	Advertising stop
01	2 characters	Advertising start

NOTE

When specifying a start point, make sure you start Advertising using this command before "[Bluetooth low energy technology Advertising Packet specifications](#)" on page 156.

Device address specifications

Format: cmd 0x08 0x0005 n6 n5 n4 n3 n2 n1

Function: Specify a BD Address. Specify a value in Little Endian.

NOTE

As a Random Static Address is used in TM-H6000V, bit7 and bit6 for n1 need to be set to 1.

Bluetooth low energy technology Advertising parameter specifications

Format: cmd 0x08 0x0006 aL aH bL bH c d e f1 f2 f3 f4 f5 f6 g h

Function: Sets a variety of parameters for the Advertising packet.

Definition	Length	Default	Description
Min advertising Interval	2 bytes	aL: 00a0h aH: 0000h	00a0h * 0.625 = 100ms Period 00a0h is the minimum that can be specified.
Max advertising Interval	2 bytes	bL: 00a0h bH: 0000h	00a0h * 0.625 = 100ms Period 00a0h is the minimum that can be specified.
Advertising type	1 bytes	c: 03h	03h: ADD_NONCONN_IND
Own address type	1 bytes	d: 01h	01h: random device address
Peer address type	1 bytes	e: 00h	00h: public device address
Peer address	6 bytes	f1-f6: 00h	No use
Advertising channel map	1 bytes	g: 07h	07h: All channel enabled
Advertising filter policy	1 bytes	h: 02h	02h: Process scan requests from all devices and only connection requests from devices that are in the White List.

See the *Bluetooth* specifications for details.

Bluetooth low energy technology Advertising Packet specifications

Format: cmd 0x08 0x0008 d1 d2 ... d32

Function: Sets the Data for the *Bluetooth* low energy technology Advertising packet.

Specify all from d1 to d32. If these are not necessary, specify 00 for each one.

Definition	Length	Default (iBeacon)	Description
Advertising data length	1 byte	d1: 1eh	1eh: 30bytes
Advertising Data	31 bytes	d2: 02h d3: 01h d4: 06h d5: 1ah d6: FFh d7: 4ch d8: 00h d9: 02h d10: 15h	02h: Length
		d11-d26: fah c1h bah 2fh 61h a2h 4dh 83h 9ah 8ch 60h 08h 7ch 23h 25h 69h	TM UUID fac1ba2fh-61a2h-4d83h-9a8ch- 60087c232569h
		d27: 00h d28: Model No.	Major number The Default specifies the ID that indicates the model type using keywords shown in "Keywords" on page 157 . You can also specify a direct value.
		d29: 00h d30: IP address 4th byte	Minor number The Default specifies the 4th sector of the IP address using keywords shown in "Keywords" on page 157 . You can also specify a direct value.
		d31: c7h	C7h: -57dB
		d32: 00h	00h: Fixed value

Keywords

You can specify the following keywords when describing the script.

Reserve String	Length	Content	Example
\$SERIAL_ADDR	6 bytes	Address that uses 1 for the MSB2bit in the last 6 digits of the printer's serial number.	When the Serial No. is ABCD123456, the Address uses 1 for the MSB2bits for the leading 1 byte in the last 6 digits. F1h:32h:33h:34h:35h:36h is generated and replaced with a string using 36h 35h 34h 33h 32h F1h sorted in Little endian.
\$RANDOM_ADDR	6 bytes	Address in which the printer generates a random 6 byte number, and 1 is for the MSB2bit of the leading 1 byte.	Generates a random 6 byte number in the printer and replaces it with a string that sorts the Address using 1 for the MSB2bits for the leading 1byte in Little endian.
\$IPn	1 byte	Value for #n in the printer's IP address.	When the IP address is 192.168.192.168, it is replaced with the following string. IP1: c0h IP2: A8h IP3: 64h IP4: c8h
\$MODEL_NO	2 bytes	Can be used for differentiating printers	0010h is used for the TM-H6000V. 0000h: No use 0001h: Reserved 0010h: TM-H6000V
\$MACn	1 byte	Value for #n in the MAC address.	Available range: \$MAC1,\$MAC2, \$MAC3, \$MAC4, \$MAC5, \$MAC6
\$BD_ADDRn	1 byte	Value for #n in the <i>Bluetooth</i> address.	Available range: \$BD_ADDR1, \$BD_ADDR2, \$BD_ADDR3, \$BD_ADDR4, \$BD_ADDR5, \$BD_ADDR6

Character Code Tables

Refer to the following URL regarding the character code table.

<http://www.epson-biz.com/pos/reference/charcode/>