

FUJITSU Server PRIMERGY RX2540 M2

Operating manual

Comments... Suggestions... Corrections...

The User Documentation Department would like to know your opinion of this manual. Your feedback helps us optimize our documentation to suit your individual needs.

Feel free to send us your comments by e-mail to manuals@ts.fujitsu.com.

Certified documentation according to DIN EN ISO 9001:2008

To ensure a consistently high quality standard and user-friendliness, this documentation was created to meet the regulations of a quality management system which complies with the requirements of the standard DIN EN ISO 9001:2008.

cognitas. Gesellschaft für Technik-Dokumentation mbH
www.cognitas.de

Copyright and Trademarks

Copyright © 2016 Fujitsu Technology Solutions GmbH.

All rights reserved.

Delivery subject to availability; right of technical modifications reserved.

All hardware and software names used are trademarks of their respective manufacturers.

- The contents of this manual may be revised without prior notice.
- Fujitsu assumes no liability for damages to third party copyrights or other rights arising from the use of any information in this manual.
- No part of this manual may be reproduced in any without the prior written permission of Fujitsu.

Microsoft, Windows, Windows Server, and Hyper-V are trademarks or registered trademarks of Microsoft Corporation in the USA and other countries.

Intel and Xeon are trademarks or registered trademarks of Intel Corporation or its subsidiaries in the USA and other countries.

Before reading this manual

For your safety

This manual contains important information for safely and correctly using this product.

Carefully read the manual before using this product. Pay particular attention to the accompanying manual "Safety Notes and Regulations" and ensure these safety notes are understood before using the product. Keep this manual and the manual "Safety Notes and Regulations" in a safe place for easy reference while using this product.

Radio interference

This product is a "Class A" ITE (Information Technology Equipment). In a domestic environment this product may cause radio interference, in which case the user may be required to take appropriate measures. VCCI-A

Aluminum electrolytic capacitors

The aluminum electrolytic capacitors used in the product's printed circuit board assemblies and in the mouse and keyboard are limited-life components. Use of these components beyond their operating life may result in electrolyte leakage or depletion, potentially causing emission of foul odor or smoke.

As a guideline, in a normal office environment (25°C) operating life is not expected to be reached within the maintenance support period (5 years). However, operating life may be reached more quickly if, for example, the product is used in a hot environment. The customer shall bear the cost of replacing replaceable components which have exceeded their operating life. Note that these are only guidelines, and do not constitute a guarantee of trouble-free operation during the maintenance support period.

High safety use

This product has been designed and manufactured to be used in commercial and/or industrial areas as a server.

When used as visual display workplace, it must not be placed in the direct field of view to avoid incommoding reflections (applies only to TX server systems).

The device has not been designed or manufactured for uses which demand an extremely high level of safety and carry a direct and serious risk of life or body if such safety cannot be assured.

These uses include control of nuclear reactions in nuclear power plants, automatic airplane flight control, air traffic control, traffic control in mass transport systems, medical devices for life support, and missile guidance control in weapons systems (hereafter, "high safety use"). Customers should not use this product for high safety use unless measures are in place for ensuring the level of safety demanded of such use. Please consult the sales staff of Fujitsu if intending to use this product for high safety use.

Measures against momentary voltage drop

This product may be affected by a momentary voltage drop in the power supply caused by lightning. To prevent a momentary voltage drop, use of an AC uninterruptible power supply is recommended.

(This notice follows the guidelines of Voltage Dip Immunity of Personal Computer issued by JEITA, the Japan Electronics and Information Technology Industries Association.)

Technology controlled by the Foreign Exchange and Foreign Trade Control Law of Japan

Documents produced by Fujitsu may contain technology controlled by the Foreign Exchange and Foreign Trade Control Law of Japan. Documents which contain such technology should not be exported from Japan or transferred to non-residents of Japan without first obtaining authorization in accordance with the above law.

Harmonic Current Standards

This product conforms to harmonic current standard JIS C 61000-3-2.

Only for the Japanese market: About SATA hard disk drives

The SATA version of this server supports hard disk drives with SATA / BC-SATA storage interfaces. Please note that the usage and operation conditions differ depending on the type of hard disk drive used.

Please refer to the following internet address for further information on the usage and operation conditions of each available type of hard disk drive:

<http://jp.fujitsu.com/platform/server/primergy/harddisk/>

Contents

1	Introduction	9
1.1	Concept and target groups for this manual	10
1.2	Documentation overview	10
1.3	Notational conventions	11
2	Functional overview	13
2.1	Features	13
2.2	Server specification	23
3	Installation steps, overview	31
4	Important information	33
4.1	Safety instructions	33
4.2	CE conformity	41
4.3	FCC Class A Compliance Statement	42
4.4	Transporting the server	43
4.5	Notes on installing the server in the rack	43
4.6	Environmental protection	44
5	Hardware installation	47
5.1	Unpacking the server	48
5.2	Installing/removing the server in/from the rack	49
5.3	Connecting devices to the server	51
5.4	Connecting the server to the power source	56
5.4.1	Connecting the server to the mains	56
5.4.2	Using the cable clamp	57

Contents

5.5	Notes on connecting/disconnecting cables	58
6	Starting up and operation	61
6.1	Controls and indicators	61
6.1.1	Front of server	61
6.1.1.1	Control elements	63
6.1.1.2	Indicators on the control panel	64
6.1.1.3	ID card	66
6.1.2	Indicators on the drives	67
6.1.3	Rear of server	68
6.2	Switching the server on and off	72
6.3	Configuring the server	75
6.3.1	Configuring the onboard SATA controller	75
6.3.2	Configuring the SAS/SATA RAID controller (PCIe expansion card)	76
6.3.3	Configuring the server and installing the operating system with the ServerView Installation Manager	77
6.3.4	Configuring the server and installing the operating system without the ServerView Installation Manager	78
6.4	Cleaning the server	79
7	Property and data protection	81
7.1	BIOS Setup security functions	81
8	Troubleshooting and tips	83
8.1	Power-on indicator remains unlit	83
8.2	Server switches itself off	84
8.3	Screen remains blank	84
8.4	Flickering stripes on monitor screen	85
8.5	No screen display or display drifts	85
8.6	Incorrect date and time	86
8.7	System will not boot	86

8.8	Hard disk drive error messages at system boot	86
8.9	Added drive reported as defective	87
8.10	Error message on screen	87
8.11	Expansion cards or onboard devices not recognized	87
8.12	Temperature warning	88
8.13	No effect of keyboard or mouse	88
8.14	Optical drive cannot read data	88

Contents

1 Introduction

The FUJITSU Server PRIMERGY RX2540 M2 sets the standard for next-generation 2U dual-socket rack servers. With best-in-class energy efficiency, serviceability, customer-inspired design and unmatched performance, the RX2540 M2 is ideal for today's demanding data centers. The modular design of the server offers excellent expandability with 24 memory slots, 8 PCIe Gen 3 expansion cards, and two hot-plug power supplies with up to 96% efficiency.

The modular power supplies are common units for the PRIMERGY mono- and dual-socket servers allowing to "right-size" the energy demands for specific requirements. In line with the Fujitsu Advanced Thermal Design (ATD) they provide highest level of power efficiency in the IT industry. Additionally the new generation of server provides DynamicLoM technology so that users can now choose the type of network adapter they want. This new DynamicLoM provides the ability to customize server's networking of today and the ability to change to meet future needs without overhauling server infrastructure. With the possible usage of up to 24 disk drives the system is ideally suited for serverized storage topics in order to build distributed storage architectures across multiple servers.

The use of the latest Intel® Xeon® E5-2600 v4 product family along with new DDR4 memory technology offers increased application performance, improved security and efficiency to be able to cope with data growth. User-inspired design features such as quick release levers for tool less fixing in a rack as well as cable management solutions for tool less mounting to rails improve serviceability.

The combination of increased processing power and memory capacity as well as enhanced management options turns the PRIMERGY RX2540 M2 into the ideal platform for running traditional databases, enterprise applications as well as collaboration and messaging workloads. Plus, it substantially simplifies carrying out infrastructure-related tasks like server virtualization and consolidation.

1.1 Concept and target groups for this manual

This operating manual describes how to install, set up and operate your server.

This operating manual is intended for those responsible for installing the hardware and ensuring that the system runs smoothly. It contains all the information you need to put your PRIMERGY RX2540 M2 into operation.

To understand the various expansion options, you will need to be familiar with the fields of hardware and data transmission and you will require a basic knowledge of the underlying operating system.

1.2 Documentation overview

More information on your PRIMERGY RX2540 M2 can be found in the following documents:

- "Quick Start Hardware - FUJITSU Server PRIMERGY RX2540 M2"
- "ServerView Quick Start Guide"
- "Safety Notes and Regulations" manual
"安全上のご注意" for the Japanese market
- "Warranty" manual
"保証書" for the Japanese market
- "ServerView Suite Local Service Concept - LSC" manual
- "Returning used devices" manual and "Service Desk" leaflet
"サポート&サービス" for the Japanese market
- "FUJITSU Server PRIMERGY RX2540 M2 Upgrade and Maintenance Manual"
- "D3289 BIOS Setup Utility for FUJITSU Server PRIMERGY RX2540 M2 Reference Manual"
- "Integrated RAID for SAS User Guide"
- "LSI MegaRAID - SAS Software User Guide"
- "Modular RAID Controller / Modular SAS HBA Installation Guide"



All documentation on PRIMERGY hardware and ServerView software is available online from the Fujitsu manuals server at:

- For the global market <http://manuals.ts.fujitsu.com>
- For the Japanese market:
<http://jp.fujitsu.com/platform/server/primergy/manual>

The complete PRIMERGY documentation set can also be downloaded as a DVD ISO image at:



- For the global market: <ftp://ftp.ts.fujitsu.com/images/serverview/manuals>
- For the Japanese market:
<http://jp.fujitsu.com/platform/server/primergy/downloads>

Further sources of information:

- ServerView Suite Glossary
- Manual for the monitor
- Documentation for the boards and drives
- Operating system documentation
- Information files in your operating system

1.3 Notational conventions

The following notational conventions are used in this manual:

<i>Text in italics</i>	indicates commands or menu items.
"Quotation marks"	indicate names of chapters and terms that are being emphasized.
▶	describes activities that must be performed in the order shown.
 CAUTION!	pay particular attention to texts marked with this symbol. Failure to observe this warning may endanger your life, destroy the system or lead to the loss of data.
	indicates additional information, notes and tips.

2 Functional overview

This section provides information on the features and technical data of the PRIMERGY RX2540 M2 server. For information on key characteristics and layout of the system board, see the "FUJITSU Server PRIMERGY RX2540 M2 Server Upgrade and Maintenance Manual".

2.1 Features

Customer Self Service (CSS)

The PRIMERGY Customer Self Service (CSS) concept enables you to identify and replace the affected component yourself in the case of certain error scenarios.

In the CSS concept, you can replace the following components yourself in the event of an error:

- Hot-plug HDD modules
- Hot-plug power supply units
- Memory modules
- Hot-plug system fans
- Expansion cards

For information on replacing these components, see the "FUJITSU Server PRIMERGY RX2540 M2 Server Upgrade and Maintenance Manual".

CSS indicators on the operation panel and on the back of the PRIMERGY server provide you with information if a CSS event arises.

In addition, CSS errors are displayed in the ServerView Operations Manager, the server management software from Fujitsu.

In the event of errors, the ServerView Operations Manager refers you directly to the affected component and its order information in the Illustrated Spares catalog of the server in question. (This feature is not available for the Japanese market.)



Further information on the CSS concept is provided in the "PRIMERGY ServerView Suite Local Service Concept - LSC" manual on the Fujitsu manuals server.

For the latest information on optional products provided for the RX2540 M2 see the configurator of the server:

http://ts.fujitsu.com/products/standard_servers/index.html
(for the global market)

<http://jp.fujitsu.com/platform/server/primergy/system/>
(for the Japanese market)

System board

The features of the system board are described in the "FUJITSU Server PRIMERGY RX2540 M2 Upgrade and Maintenance Manual", the setup possibilities are described in the "D3289 BIOS Setup Utility for FUJITSU Server PRIMERGY RX2540 M2 Reference Manual".

USB Flash Module (UFM) (option)

The system board is equipped with a UFM slot by the manufacturer.

Trusted Platform Module (TPM)

A Trusted Platform Module (TPM) for safer storage of keys can be implemented as an option. This module enables programs from third party manufacturers to store key information (e.g. drive encryption using Windows Bitlocker Drive Encryption).

The TPM is activated via the BIOS system (for more information, refer to the "D3289 BIOS Setup Utility for FUJITSU Server PRIMERGY RX2540 M2 Reference Manual").



CAUTION!

- When using the TPM, note the program descriptions provided by the third party manufacturers.
- You must also create a backup of the TPM content. To do this, follow the third party manufacturer's instructions. Without this backup, if the TPM or the system board is faulty you will not be able to access your data.

- If a failure occurs, please inform your service about the TPM activation before it takes any action, and be prepared to provide them with your backup copies of the TPM content.

Slots for expansion cards

The server can be flexibly expanded via six low profile PCIe Gen3 low profile adapters (4 PCIe x8, 2 PCIe x16).

One horizontal chassis slot is occupied by the dynamic LOM card.

Hard disk drives - 3.5-inch

The server is available in the following drive configurations:

- 4x 3.5-inch version:
 - Up to four SATA hard disk drives connected to SATA 1-4 onboard. One slot for an optional 3.5-inch ODD drive.
 - Up to four SAS hard disk drives connected to SAS RAID controller. One slot for an optional 3.5-inch ODD drive.
- 8x 3.5-inch version:
 - Up to eight SATA hard disk drives connected to SATA 1-4 and SATA 7-10 onboard. One slot for an optional 3.5-inch ODD drive.
 - Up to eight SAS hard disk drives connected to SAS RAID controller. One slot for an optional 3.5-inch ODD drive.
- 12x 3.5-inch SAS/SATA hard disk drives connected to SAS RAID controller: up to twelve HDD modules, each with a 3.5-inch SAS/SATA hard disk drive with a maximum height of 1 inch.

The HDD modules are connected to the SAS/SATA backplane without cables. This allows HDD modules to be simply plugged in or pulled out (for further details see the "FUJITSU Server PRIMERGY RX2540 M2 Server Upgrade and Maintenance Manual").

If the server has a RAID configuration, the HDD modules can be exchanged during operation (hot-swap).

Hard disk drives - 2.5-inch

The server is available in the following drive configurations:

- 8x 2.5-inch version:
 - Up to eight SATA hard disk drives connected to SATA 1-4 and SATA 7-10 onboard. One 5.25-inch bay for an optional ODD and/or LTO or RDX drive.
 - Up to eight SAS hard disk drives connected to SAS RAID controller. One 5.25-inch bay for an optional ODD and/or LTO or RDX drive.

For LTO drive an additional SAS controller must be installed because onboard SAS is no more supported.

- 16x 2.5-inch SAS/SATA hard disk drives connected to SAS RAID controller: up to sixteen HDD modules, each with a 2.5-inch SAS/SATA hard disk drive with a maximum height of 1 inch. One 5.25-inch bay for an optional LTO or RDX drive.

To support 16 HDDs you need either the new SAS expander board or a second RAID controller.

- 24x 2.5-inch SAS/SATA hard disk drives connected to SAS RAID controller: up to twenty-four HDD modules, each with a 2.5-inch SAS/SATA hard disk drive with a maximum height of 1 inch. The option of ODD, LTO or RDX drive is not available.

To support 24 HDDs you need the new SAS expander board.

The HDD modules are connected to the SAS/SATA backplane without cables. This allows HDD modules to be simply plugged in or pulled out (for further details see the "FUJITSU Server PRIMERGY RX2540 M2 Server Upgrade and Maintenance Manual").

If the server has a RAID configuration, the HDD modules can be exchanged during operation (hot-swap).

Onboard SATA controller

One SATA controller is integrated on the system board; up to eight SATA hard disk drives can be connected to the controller. The LSI Embedded MegaRAID software (Software RAID) supports RAID levels 0, 1 and 10.

For more information on configuring the controller, see section ["Configuring the onboard SATA controller" on page 75](#).

SAS/SATA RAID controller (pluggable PCI-e expansion card)

The server is available with the following SAS/SATA RAID controllers for operating the internal SAS/SATA hard disk drives:

- Modular RAID 0/1 controller with "MegaRAID functionality" (SAS MegaRAID) for SAS1.0 and SAS2.0

RAID levels 0, 1 and 10 are supported for internal hard disk drive configurations.

- Modular RAID 5/6 controller with "MegaRAID functionality" (SAS MegaRAID) for SAS1.0 and SAS2.0

RAID levels 0, 1, 10, 5, 50, 6 and 60 are supported for internal hard disk drive configurations. As an option, a flash backup unit (FBU) can save the memory content even if the power fails. Cache memory size of 1 Gbyte or 2 Gbyte is available.



For more information on configuring the controller, see section ["Configuring the SAS/SATA RAID controller \(PCIe expansion card\)" on page 76](#).

Further information on SAS/SATA RAID controllers is provided in the "Modular RAID Controller Installation Guide" (on the Fujitsu manuals server under *x86 Servers - Expansion Cards - Storage Adapters - LSI SAS / SCSI RAID Controllers*).

Further information on other SAS/SATA RAID controllers (e.g. for operating external SAS/SATA hard disk drives or tape drives) is available on the Fujitsu manuals server under *x86 Servers - Expansion Cards - Storage Adapters - LSI SAS / SCSI RAID Controllers*.

Accessible drives / components

For configurations with 4 *3.5-inch and 8*3.5-inch HDD modules, a 3.5-inch slimline bay for an optional optical drive is configurable.

For configurations with 8*2.5-inch and 16*2.5-inch HDD modules, a 5.25-inch bay for an ODD, LTO or RDX drive is configurable.

Functional overview

USB connectors

Up to 8x 3.5-inch and up to 16x 2.5-inch: Two USB 3.0 connectors on the front of the device support activities carried out by the service technician. The maximum length of the external cable is two meters for the USB connectors on the front. At the rear there are 2x USB 3.0 and 2x USB 2.0.

12x 3.5-inch and 24x 2.5-inch: On the front there is one USB 2.0 connector. At the rear there are 2x USB 3.0 and 2x USB 2.0.

Power supply

In its basic configuration, the server has a hot-pluggable power supply unit that adjusts automatically to any power voltage in the range from 100 V to 240 V (Platinum) or 200 V to 240 V (Titanium). As an option, the power supply can be expanded with an extra power supply unit to create a redundant power supply. If a power supply unit fails, the redundant configuration assures continued operation. The defective power supply unit can be replaced during operation (for further details see the "FUJITSU Server PRIMERGY RX2540 M2 Server Upgrade and Maintenance Manual").

Fujitsu Advanced Thermal Design

The Fujitsu Advanced Thermal Design option allows you to operate the system with a wider temperature range either of 5 °C to 40 °C or 5 °C to 45 °C, depending on your system and configuration.



This option can only be ordered from the manufacturer and is indicated by the respective logo on the identification rating plate.



CAUTION

In a system that is configured with Fujitsu Advanced Thermal Design, only certain components which support the respectively increased higher operating temperature range may be installed and used. For applicable restrictions, please refer to the official configurator tool.

High level of availability and data security

When memory data is accessed, 1-bit errors are identified in the main memory and automatically corrected with the error correcting code (ECC) method. The patented memory scrubbing function regularly starts up the EDC mechanism, ensuring continuous data integrity.

The memory modules used support SDDC technology (Chipkill™), which further increases the effectiveness of memory error monitoring and correction.

Rank sparing memory technology is also supported, whereby one memory module is used as a replacement for two other memory modules. If a memory module fails, the module with the defective memory is deactivated automatically and the replacement module is activated (provided that it has been configured accordingly in BIOS; see *BIOS Setup*). The deactivated memory module is no longer used and the faulty memory module can be replaced at the next opportunity. The spare rank module must have identical or larger memory capacity than all the other ranks on the same channel.

Memory modules can be protected against failure by mirroring (Memory Mirroring). Memory Mirroring is roughly comparable to RAID level 1 for hard disk arrays.



For further information according to memory module population please refer to the technical manual of the system board D3289.

ASR&R (Automatic Server Reconfiguration and Restart) restarts the system in the event of an error and automatically "hides" the defective system components.

The PDA (Prefailure Detection and Analyzing) technology from Fujitsu analyzes and monitors all components that are critical for system reliability.

The RAID functionality of the SAS RAID controller increases the availability of the system.

The hot-plug HDD modules provide additional availability.

iRMC S4 with integrated management LAN connector

The iRMC S4 (integrated **R**emote **M**anagement **C**ontroller) is a Baseboard Management Controller (BMC) with integrated management LAN connector and expanded functionality that was previously only available with additional plug-in cards. In this way, the iRMC S4 enables complete control of PRIMERGY servers, regardless of system status, and thus particularly the control of PRIMERGY servers that are in the "out-of-band" system status.

Functional overview

Major functions supported by the iRMC S4 include the following:

- Browser access via iRMC S4's own Web server
- Secure communication (SSH, SSL)
- Power Management for the managed server (depending on its system status)
- Power Consumption Management
- Connecting virtual drives as remote storage
- Text-based and graphic console bypass (Advanced Video Redirection)
- Remote Storage
- Command Line Interface (CLI)
- Simple, interactive or script-based iRMC S4 configuration
- Customer Self Service (CSS)
- iRMC S4's own user management
- Multi-computer, global iRMC S4 user administration using an LDAP Directory Service
- Automatic network configuration via DNS / DHCP
- Power supply of the iRMC S4 via the system standby supply
- Full-coverage alarm management
- System Event Log (SEL) reading and processing
- IPMI support
- CIM / WS-MAN support
- Internal Event Log for user login / logout auditing

More information about the iRMC S4 can be found in the "iRMC S4 - integrated Remote Management Controller" user guide (on the Fujitsu manuals server under *x86 Servers - Software - ServerView Suite - Out-Of-Band Management*).

Server management

Server management is implemented using the ServerView Operations Manager supplied and the PDA (Prefailure Detection and Analysis) technology from Fujitsu. PDA reports the threat of a system error or overload at an early stage, allowing preventive measures to be taken.

The ServerView Operations Manager enables the management of all PRIMERGY servers in the network via a central console. The ServerView Operations Manager supports the following functions:

- Round-the-clock monitoring, regardless of server status
- High-performance, graphical console bypass (AVR) protected by HTTPS/SSL (128 bit)
- Remote storage via USB
- Remote power on
- Temperature monitoring of the CPU and the surrounding area
- Detailed status and error reports for processors and main memory
- Watchdog timer for Automatic Server Reconfiguration and Restart (ASR&R) in the event that memory modules or processors fail
- Power monitoring
- End-of-life monitoring of fans with prompt notification before failure
- Watchdog timer for monitoring the operating system with ASR&R

Further information on the ServerView Operations Manager is provided in the associated documentation.

ServerView Installation Manager

You can configure the PRIMERGY server quickly and precisely with the ServerView Installation Manager software provided. User-guided menus are available for installing the server operating system (for further details see section ["Configuring the server" on page 75](#)).

Service and support

PRIMERGY servers are easy to maintain and modular, thus enabling quick and simple maintenance.

The handles and locks (touch points) used to exchange components are colored green to ensure simple and immediate recognition.

In order to prevent the components from being damaged by incorrect handling when they are being installed and removed, the areas of all components that can be touched without damaging them are also marked green.

Functional overview

PRIMERGY diagnostic LEDs fitted on the system board indicate which component (memory module, processor, fan or expansion card) is not functioning properly.

The Flash EPROM program supplied with the Fujitsu utilities supports a fast BIOS update.

With the iRMC (integrated Remote Management Controller) on the system board, the PRIMERGY RX2540 M2 server can also be maintained and serviced remotely. This enables remote diagnosis for system analysis, remote configuration and remote restart should the operating system or hardware fail.

ServerView Remote Management

ServerView Remote Management is the remote management solution from Fujitsu for PRIMERGY servers. ServerView Remote Management and the relevant hardware components integrated on the system board allow remote monitoring and maintenance as well as fast restoration of operation in the event of errors.

Remote monitoring and maintenance avoids time-consuming and costly on-site repairs and reduces service costs. This leads to a reduction in the total cost of ownership and an excellent return on investment for the remote management solution.

The administrator can access all system information and information from the sensors such as fan speeds or voltages via the iRMC S4's Web interface (see section ["iRMC S4 with integrated management LAN connector" on page 19](#)). You can also start the text-based or graphic console bypass (Advanced Video Redirection, AVR) and connect virtual drives as remote storage.



More information about the iRMC S4 can be found in the "iRMC S4 - integrated Remote Management Controller" user guide (on the Fujitsu manuals server under *x86 Servers - Software - ServerView Suite - Out-Of-Band Management*).

2.2 Server specification

This section explains the specifications for the server. The specifications for this server are liable to be updated without any notice. Please be forewarned.

System Board

System board type	D3289
Chipset	Intel® C610 series

Processor

Processor quantity and type	1 or 2 Intel® Xeon® E5-2600 v4 family processors
-----------------------------	--

Memory Modules Configuration

Memory slots	24
Memory slot type	DDR4
Memory capacity (min. - max.)	8 GB - 1536 GB
Memory protection	Memory Scrubbing; SDDC (Chipkill™)
Memory notes	max. 12 memory modules/CPU with single or dual-rank LRDIMM.

Functional overview

Interfaces

USB	3.5"x4 and 2.5"x8 variants: 5 x USB 3.0 (2 x front, 2 x rear, 1 x internal); 2 x USB 2.0 (rear) 3.5"x12 and 2.5"x24 variants: 3x USB 3.0 (2x rear, 1x internal) 3x USB 2.0 (1x front, 2x rear)
Graphics (15-pin)	2 x VGA (thereof 1x front optional)
Serial	1 x serial RS-232C (optional), usable for iRMC or system or shared
LAN / Ethernet	Dynamic LoM (LAN on Motherboard) option: <ul style="list-style-type: none">– 2 x 1 GBit/s (RJ45)– 4 x 1 GBit/s (RJ45)– 2 x 10 GBit/s (RJ45)– 2 x 10 GBit/s (SFP+)
Management LAN (RJ45)	1 x dedicated management LAN port for iRMC S4 (10/100/1000 Mbit/s) Management LAN traffic can be switched to shared onboard converged network adapter

Onboard or integrated controllers

RAID controller	Two 4 port internal 6G SATA for HDDs with RAID level 0/1/10. For additional RAID controller options are described under " RAID controllers (expansion cards) " on page 25
SATA controller	Intel® C612, 1 x SATA channel for ODD
LAN Controller	Emulex converged network adapter, 4x 10 Gbit/s PXE-Boot via LAN from PXE server, iSCSI boot (also diskless).

Remote Management Controller	Integrated Remote Management Controller (iRMC S4), 256 MB DDR3-800 SRAM for video, IPMI 2.0 compatible
Trusted Platform Module (TPM)	Infineon / separate module; TCG V1.2 compliant (option)

RAID controllers (expansion cards)

RAID controllers	<p>RAID 5/6 Ctrl., HDD SAS up to 12 Gbit/s, LSI, 8 ports ext. RAID level: 0, 1, 10, 5, 50, 6, 60, 1 GB Cache, Optional FBU (based on LSI SAS3108).</p> <p>RAID 5/6 Ctrl., HDD SAS up to 12 Gbit/s, 8 ports int. RAID level: 0, 1, 10, 5, 50, 6, 60, 2 GB Cache, Optional FBU (based on LSI SAS3108).</p> <p>RAID 0/1 Ctrl., SAS/SATA 6 Gb, 8 ports int. RAID level: 0, 1, 10, No FBU support.</p>
------------------	---

Slots

PCI-Express - Gen3 x16	3 x low profile
PCI-Express - Gen3 x8	3 x low profile
Slot notes	<p>CPU1 supports two slots PCIe x8 and one slot PCIe x16. Slot 2 can be equipped also with an X16 card.</p> <p>Thereof one PCIe x8 slot may be occupied with a Modular RAID controller.</p> <p>CPU2 supports one slot PCIe x8 and two slots PCIe x16.</p>

Functional overview

Drive bays

Hard disk bay configuration	4x 3.5-inch, 8x3.5-inch, 12x 3.5-inch for SAS/SATA 8x 2.5-inch, 16x2.5-inch, 24x 2.5-inch for SAS/SATA
Accessible drive bays	1 x 5.25/0.5-inch for ODD drive
Notes accessible drives	all possible options described in relevant system configurator

Operating Panel

Operating buttons	On/off button
	Reset button
	NMI button
	ID button
Status LEDs	Global error indicator (orange)
	ID indicator (blue)
	HDD activity indicator (green)
	Power-on indicator (green)
	AC connected indicator (green)
	CSS indicator (orange)
Status LEDs at system rear side:	Global error / CSS / ID indicator (orange / orange / blue)
	LAN connection indicator (green)
	LAN speed indicator (green / yellow)

Dimensions / Weight

Rack (W x D x H)	482.6 mm (bezel) / 445 mm (chassis outer dimension) / 430.8 mm (chassis) x 764 mm (outer dimension) x 86.6 mm
Mounting depth rack	745 mm
Height unit rack	2 U
19" rackmount	Yes

Mounting cable depth rack	100 mm (1000 mm rack recommended)
Weight	25 kg
Weight notes	actual weight may vary depending on configuration
Rack mounting kit	rack mounting kit as option

Ambient conditions

Environment class 3K2 Environment class 2K2	EN 60721 / IEC 721 Part 3-3 EN 60721 / IEC 721 Part 3-2
Temperature: Operation (3K2) Transport (2K2)	5°C ... 40°C (with Fujitsu ATD 40°C) 5°C ... 45°C (with Fujitsu ATD 45°C) 10°C ... 35°C (without Fujitsu ATD) - 25°C ... 60°C
Humidity	10% ... 85% (non condensing)

Condensation during operation must be avoided!

Functional overview

Noise level (depending on the configuration)

The acoustic noise values are depending on the system configuration.

Standard configuration	
Sound power level L_{WA_d} (ISO 9296)	< 6.2 B (standby) < 6.2 B (operation) < 8.1 B (full fan speed)
Sound pressure level at adjacent workstation L_{pAm} (ISO 9296)	< 44 db(A) (standby) < 44 db(A) (operation) < 63 db(A) (full fan speed)

Electrical data: 450 W Platinum

Rated voltage range	100 V - 240 V
Frequency	50 Hz / 60 Hz
Max. rated current	4.5 A - 2.0 A

Electrical data: 800 W Platinum

Rated voltage range	100 V - 240 V
Frequency	50 Hz / 60 Hz
Max. rated current	8.0 A - 3.5 A

Electrical data: 800 W Titanium

Rated voltage range	200 V - 240 V
Frequency	50 Hz / 60 Hz
Max. rated current	4.5 A

Electrical data: 1200 W Platinum

Rated voltage range	100 V - 240 V
Frequency	50 Hz / 60 Hz
Max. rated current	10.0 A - 4.5 A

Screen resolution

The screen resolutions in the following table refer to the graphics controller on the system board. The graphics controller is integrated in the iRMC (integrated Remote Management Controller).

Screen resolution (pixel)	Maximum refresh rate (Hz)	Max. number of colours
640x480	85	32 bit
800x600	85	32 bit
1024x768	85	32 bit
1152x864	75	32 bit
1280x1024	60	32 bit
1600x1200	60	16 bit
1920x1080	60	16 bit
1920x1200	60	16 bit

If you are using an external graphics controller, you will find details of supported screen resolutions in the Operating Manual or Technical Manual supplied with the graphics controller.

Functional overview

Compliance with regulations and standards

Product safety and ergonomics	
International	IEC 60950-1 2ed; am1
Europe	
Safety	EN 60950-1 2ed.; am1 EN 62479 EN 62311
Ergonomics	ISO 9241-3 EN 2941-3 EK1-ITB2000:2013
USA / Canada	CSA-C22.2 No. 60950-1-07 2ed. UL 60950-1 2ed.
Taiwan	CNS 14336
China	GB 4943
Electromagnetic compatibility	
International	CISPR 22
Europe	EN 55022 Class A EN 55024 EN 61000-3-2 EN 61000-3-3 ETSI 300386
USA / Canada	47CFR part 15 Class A / ICES-003
Taiwan	CNS 13438 Class A
China	GB 9245 / GB 17625
Japan	VCCI Class A / JEITA
Korea	KN 22 / KN 24
CE marking to EU directives	Low Voltage Directive 2006/95/EC Electromagnetic compatibility 2004/108/EC Restriction of hazardous substances 2011/65/EU

3 Installation steps, overview

This chapter contains an overview of the steps necessary to install your server. Links take you to sections where you can find more detailed information about the respective steps:

- ▶ First of all, carefully read the safety instructions in ["Important information" on page 33](#) and following.
- ▶ Transport the server to the place where you want to set it up.
- ▶ Unpack the system, check the contents of the package for visible transport damage and check whether the items delivered correspond to the details on the delivery note (see ["Unpacking the server" on page 48](#)).
- ▶ Make sure that you have all necessary manuals (see ["Documentation overview" on page 10](#)); print out the PDF files if required.
- ▶ Components that have been ordered additionally may be delivered loose with the server. For mounting refer to the original component documentation.
- ▶ Mount the server into the rack (see ["Installing/removing the server in/from the rack" on page 49](#)).
- ▶ Wire the server. To do this, refer to sections ["Connecting devices to the server" on page 51](#) and ["Notes on connecting/disconnecting cables" on page 58](#).
- ▶ Connect the server to the mains (see ["Connecting the server to the power source" on page 56](#)).
- ▶ Familiarize yourself with the controls and indicators on the front and rear of the server (see section ["Controls and indicators" on page 61](#)).

- ▶ Configure the server and install the desired operating system and applications. The following options are available:
 - Remote installation with the ServerView Installation Manager:

With the ServerView Suite DVD provided, you can configure the server and install the operating system in a convenient manner.

Details on how to operate the ServerView Installation Manager, as well as some additional information, are included in the "ServerView Suite Installation Manager" user's guide (on the Fujitsu manuals server under *x86 Servers - Software - ServerView Suite - Server Installation and Deployment*).

Configuration information can also be found in section "[Configuring the server and installing the operating system with the ServerView Installation Manager](#)" on page 77.
 - Local configuration and installation with or without the ServerView Installation Manager (see section "[Configuring the server and installing the operating system with the ServerView Installation Manager](#)" on page 77 or section "[Configuring the server and installing the operating system without the ServerView Installation Manager](#)" on page 78).
- i** You will find more information on installing the server remotely or locally in the "ServerView Suite Installation Manager" user's guide (on the Fujitsu manuals server under *x86 Servers - Software - ServerView Suite - Server Installation and Deployment*).

4 Important information

In this chapter you will find essential information regarding safety when working on your server.

4.1 Safety instructions



The following safety instructions are also provided in the manual "Safety Notes and Regulations" or "安全上のご注意".

This device meets the relevant safety regulations for IT equipment. If you have any questions about whether you can install the server in the intended environment, please contact your sales outlet or our customer service team.



CAUTION!

- The actions described in this manual shall be performed by technical specialists. A technical specialist is a person who is trained to install the server including hardware and software.
- Repairs to the device that do not relate to CSS failures shall be performed by service personnel. Please note that unauthorized interference with the system will void the warranty and exempt the manufacturer from all liability.
- Any failure to observe the guidelines in this manual, and any improper repairs could expose the user to risks (electric shock, energy hazards, fire hazards) or damage the equipment.
- Before installing/removing internal options to/from the server, turn off the server, all peripheral devices, and any other connected devices. Also unplug all power cords from the power outlet. Failure to do so can cause electric shock.

Before starting up



CAUTION!

- During installation and before operating the device, observe the instructions on environmental conditions for your device (see ["Ambient conditions" on page 27](#)).
- If the server has been moved from a cold environment, condensation may form both inside and on the outside of the machine.

Wait until the server has acclimatized to room temperature and is absolutely dry before starting it up. Material damage may be caused to the server if this requirement is not met.

- Only transport the server in the original packaging or in packaging that protects it from impacts and jolts.

Installation and operation



CAUTION!

- This unit should not be operated in ambient temperatures above 35 °C. For servers with Fujitsu Advanced Thermal Design the ambient temperature can increase to 40 °C or 45 °C.
- If the unit is integrated into an installation that draws power from an industrial power supply network with an IEC309 connector, the power supply's fuse protection must comply with the requirements for non-industrial power supply networks for type A connectors.
- The unit automatically adjusts itself to a mains voltage in a range of 100 V to 240 V (Platinum) or 200 V to 240 V (Titanium). Ensure that the local mains voltage lies within these limits.
- This device must only be connected to properly grounded power outlets or insulated sockets of the rack's internal power supply with tested and approved power cords.
- Ensure that the device is connected to a properly grounded power outlet close to the device.



CAUTION!

- Ensure that the power sockets on the device and the properly grounded power outlets are freely accessible.
- The On/Off button or the main power switch (if present) does not isolate the device from the mains power supply. To disconnect it completely from the mains power supply, unplug all network power plugs from the properly grounded power outlets.
- Always connect the server and the attached peripherals to the same power circuit. Otherwise you run the risk of losing data if, for example, the server is still running but a peripheral device (e.g. memory subsystem) fails during a power outage.
- Data cables must be adequately shielded.
- Ethernet cabling has to comply with EN 50173 and EN 50174-1/2 standards or ISO/IEC 11801 standard respectively. The minimum requirement is a Category 5 shielded cable for 10/100 Ethernet, or a Category 5e cable for Gigabit Ethernet.
- Route the cables in such a way that they do not create a potential hazard (make sure no-one can trip over them) and that they cannot be damaged. When connecting the server, refer to the relevant instructions in this manual.
- Never connect or disconnect data transmission lines during a storm (risk of lightning hazard).
- Make sure that no objects (e.g. jewelry, paperclips etc.) or liquids can get inside the server (risk of electric shock, short circuit).
- In emergencies (e.g. damaged casing, controls or cables, penetration of liquids or foreign bodies), switch off the server immediately, remove all power plugs and contact your sales outlet or customer service team.
- Before removing the airduct unplug all network power plugs from the properly grounded power outlets (rotating fans).



CAUTION!

- Proper operation of the system (in accordance with IEC 60950-1/2 resp. EN 60950-1/2) is only ensured if the casing is completely assembled and the rear covers for the installation slots have been fitted (electric shock, cooling, fire protection, interference suppression).
- Only install system expansions that satisfy the requirements and rules governing safety and electromagnetic compatibility and those relating to telecommunication terminals. If you install other expansions, they may damage the system or violate the safety regulations. Information on which system expansions are approved for installation can be obtained from our customer service center or your sales outlet.
- The components marked with a warning notice (e.g. lightning symbol) may only be opened, removed or exchanged by authorized, qualified personnel. Exception: CSS components can be replaced.
- The warranty is void if the server is damaged during installation or replacement of system expansions.
- Only set screen resolutions and refresh rates that are specified in the operating manual for the monitor. Otherwise, you may damage your monitor. If you are in any doubt, contact your sales outlet or customer service center.
- Before installing/removing internal options to/from the server, turn off the server, all peripheral devices, and any other connected devices. Also unplug all power cords from the outlet. Failure to do so can cause electric shock.
- Do not damage or modify internal cables or devices. Doing so may cause a device failure, fire, or electric shock.
- Devices inside the server remain hot after shutdown. Wait for a while after shutdown before installing or removing internal options.
- The circuit boards and soldered parts of internal options are exposed and can be damaged by static electricity. Before handling them, first touch a metal part of the server to discharge static electricity from your body.
- Do not touch the circuitry on boards or soldered parts. Hold the metallic areas or the edges of the circuit boards.



CAUTION!

- Install the screw removed during installation/detaching Internal Options in former device/position. To use a screw of the different kind causes a breakdown of equipment.
- The installation indicated on this note is sometimes changed to the kind of possible options without notice.

Batteries



CAUTION!

- Incorrect replacement of batteries may lead to a risk of explosion. The batteries may only be replaced with identical batteries or with a type recommended by the manufacturer (refer to the "FUJITSU Server PRIMERGY RX2540 M2 Upgrade and Maintenance Manual").
- Do not throw batteries into the trash can.
- Batteries must be disposed of in accordance with local regulations concerning special waste.
- Replace the lithium battery on the system board in accordance with the instructions in the "FUJITSU Server PRIMERGY RX2540 M2 Upgrade and Maintenance Manual".
- All batteries containing pollutants are marked with a symbol (a crossed-out garbage can). In addition, the marking is provided with the chemical symbol of the heavy metal decisive for the classification as a pollutant:

Cd Cadmium

Hg Mercury

Pb Lead

Working with CDs/DVDs/BDs and optical drives

When working with devices with optical drives, these instructions must be followed.



CAUTION!

- Only use CDs/DVDs/BDs that are in perfect condition, in order to prevent data loss, equipment damage and injury.
- Check each CD/DVD/BD for damage, cracks, breakages etc. before inserting it in the drive.

Note that any additional labels applied may change the mechanical properties of a CD/DVD/BD and cause imbalance.

Damaged and imbalanced CDs/DVDs/BDs can break at high drive speeds (data loss).

Under certain circumstances, sharp CD/DVD/BD fragments can pierce the cover of the optical drive (equipment damage) and can fly out of the device (danger of injury, particularly to uncovered body parts such as the face or neck).

- High humidity and airborne dust levels are to be avoided. Electric shocks and/or server failures may be caused by liquids such as water, or metallic items, such as paper clips, entering a drive.
- Shocks and vibrations are also to be avoided.
- Do not insert any objects other than the specified CDs/DVDs/BDs.
- Do not pull on, press hard, or otherwise handle the CD/DVD/BD tray roughly.
- Do not disassemble the optical drive.
- Before use, clean the optical disk tray using a soft, dry cloth.
- As a precaution, remove disks from the optical drive when the drive is not to be used for a long time. Keep the optical disk tray closed to prevent foreign matter, such as dust, from entering the optical drive.
- Hold CDs/DVDs/BDs by their edges to avoid contact with the disk surface.

- Do not contaminate the CD/DVD/BD surface with fingerprints, oil, dust, etc. If dirty, clean with a soft, dry cloth, wiping from the center to the edge. Do not use benzene, thinners, water, record sprays, antistatic agents, or silicone-impregnated cloth.
- Be careful not to damage the CD/DVD/BD surface.
- Keep the CDs/DVDs/BDs away from heat sources.
- Do not bend or place heavy objects on CDs/DVDs/BDs.
- Do not write with ballpoint pen or pencil on the label (printed) side.
- Do not attach stickers or similar to the label side. Doing so may cause rotational eccentricity and abnormal vibrations.
- When a CD/DVD/BD is moved from a cold place to a warm place, moisture condensation on the CD/DVD/BD surface can cause data read errors. In this case, wipe the CD/DVD/BD with a soft, dry cloth in a radial way then let it air dry. Do not dry the CD/DVD/BD using devices such as a hair dryer.
- To avoid dust, damage, and deformation, keep the CD/DVD/BD in its case whenever it is not in use.
- Do not store CDs/DVDs/BDs at high temperatures. Areas exposed to prolonged direct sunlight or near heating appliances are to be avoided.



You can prevent damage from the optical drive and the CDs/DVDs/BDs, as well as premature wear of the disks, by observing the following suggestions:

- Only insert disks in the drive when needed and remove them after use.
- Store the disks in suitable sleeves.
- Protect the disks from exposure to heat and direct sunlight.

Laser information

The optical drive complies with IEC 60825-1 laser class 1.



CAUTION!

The optical drive contains a light-emitting diode (LED), which under certain circumstances produces a laser beam stronger than laser class 1. Looking directly at this beam is dangerous.

Never remove parts of the optical drive casing!

Modules with Electrostatic-Sensitive Devices

Modules with electrostatic-sensitive devices are identified by the following sticker:

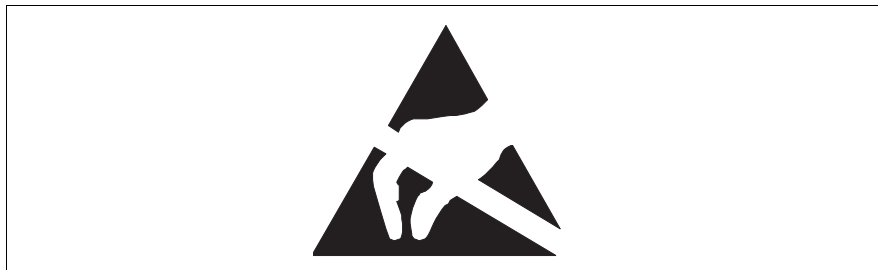

Figure 1: ESD label

When you handle components fitted with ESDs, you must always observe the following points:

- Switch off the system and remove the power plugs from the power outlets before installing or removing components with ESDs.
- You must always discharge static build-up (e.g. by touching a grounded object) before working with such components.
- Any devices or tools that are used must be free of electrostatic charge.
- Wear a suitable grounding cable that connects you to the external chassis of the system unit.
- Always hold components with ESDs at the edges or at the points marked green (touch points).
- Do not touch any connectors or conduction paths on an ESD.
- Place all the components on a pad which is free of electrostatic charge.



For a detailed description of how to handle ESD components, see the relevant European or international standards (EN 61340-5-1, ANSI/ESD S20.20).

Other important information:

- During cleaning, observe the instructions in section "[Cleaning the server](#)" on [page 79](#).
- Keep this operating manual and the other documentation close to the device. All documentation must be included if the equipment is passed on to a third party.

4.2 CE conformity



The system complies with the requirements of the EC directives 2004/108/EC regarding "Electromagnetic Compatibility" and 2006/95/EC "Low Voltage Directive" and the directive of the European Parliament and Council 2011/65/EU. This is indicated by the CE marking (CE = Communauté Européenne).

4.3 FCC Class A Compliance Statement

If there is an FCC statement on the device, it applies to the products covered in this manual, unless otherwise specified herein. The statement for other products will appear in the accompanying documentation.

NOTE:

This equipment has been tested and found to comply with the limits for a "Class A" digital device, pursuant to Part 15 of the FCC rules and meets all requirements of the Canadian Interference-Causing Equipment Standard ICES-003 for digital apparatus. These limits are designed to provide reasonable protection against harmful interference in a residential installation. This equipment generates, uses and can radiate radio frequency energy and, if not installed and used in strict accordance with the instructions, may cause harmful interference to radio communications. However, there is no warranty that interference will not occur in a particular installation. If this equipment does cause harmful interference to radio or television reception, which can be determined by turning the equipment off and on, the user is encouraged to try to correct the interference by one or more of the following measures:

- Reorient or relocate the receiving antenna.
- Increase the separation between equipment and the receiver.
- Connect the equipment into an outlet on a circuit different from that to which the receiver is connected.
- Consult the dealer or an experienced radio/TV technician for help.

Fujitsu is not responsible for any radio or television interference caused by unauthorized modifications of this equipment or the substitution or attachment of connecting cables and equipment other than those specified by Fujitsu. The correction of interferences caused by such unauthorized modification, substitution or attachment will be the responsibility of the user.

The use of shielded I/O cables is required when connecting this equipment to any and all optional peripheral or host devices. Failure to do so may violate FCC and ICES rules.

WARNING:

This is a class A product. In a domestic environment this product may cause radio interference in which case the user may be required to take adequate measures.

4.4 Transporting the server



CAUTION!

Only transport the server in its original packaging or in packaging that protects it from impacts and jolts. Do not unpack the server until it is at its installation location.

If you need to lift or transport the server, ask other people to help you.

Never lift or carry the device by the Quick Release Levers (QRLs) on the front panel.

4.5 Notes on installing the server in the rack



CAUTION!

- For safety reasons, at least two people are required to install the server in the rack because of its weight and size.
(For the Japanese market, please refer to "安全上のご注意".)
- Never lift the server into the rack using the QRLs (Quick Release Levers) on the front panel.
- When connecting and disconnecting cables, observe the relevant instructions in the "Important Information" chapter of the technical manual for the corresponding rack. The technical manual is supplied with the corresponding rack.
- When installing the rack, make sure that the anti-tilt mechanism is correctly fitted.
- Do not extend more than one unit out of the rack simultaneously even if the tilt protection is in place. If several units are simultaneously extended from the rack, there is a risk that the rack could tip over. See the safety information of the rack and the warning label.
- Only for the EMEA market:
The rack must be connected to the power supply by an authorized specialist (electrician).
- If the server is integrated into an installation that draws power from an industrial power supply network with an IEC309 type connector, the power supply's fuse protection must comply with the requirements for non-industrial power supply networks for the type A connector.

4.6 Environmental protection

Environmentally-friendly product design and development

This product has been designed in accordance with the Fujitsu standard for "environmentally friendly product design and development". This means that key factors such as durability, selection and labeling of materials, emissions, packaging, ease of dismantling and recycling have been taken into account.

This saves resources and thus reduces the harm done to the environment. Further information can be found at:

- http://ts.fujitsu.com/products/standard_servers/index.html (for the global market)
- <http://jp.fujitsu.com/platform/server/primergy/concept/> (for the Japanese market)

Energy-saving information

Devices that do not need to be constantly switched on should be switched off until they are needed as well as during long breaks and after completion of work.

Packaging information

This packaging information doesn't apply to the Japanese market.

Do not throw away the packaging. You may need it later for transporting the system. If possible, the equipment should only be transported in its original packaging.

Information on handling consumables

Please dispose of printer consumables and batteries in accordance with the applicable national regulations.

In accordance with EU directives, batteries must not be disposed of with unsorted domestic waste. They can be returned free of charge to the manufacturer, dealer or an authorized agent for recycling or disposal.

All batteries containing pollutants are marked with a symbol (a crossed-out garbage can). They are also marked with the chemical symbol for the heavy metal that causes them to be categorized as containing pollutants:

Cd Cadmium
Hg Mercury
Pb Lead

Labels on plastic casing parts

Please avoid sticking your own labels on plastic parts wherever possible, since this makes it difficult to recycle them.

Returns, recycling and disposal

Please handle returns, recycling and disposal in accordance with local regulations.



The device must not be disposed of with domestic waste. This device is labeled in compliance with European directive 2002/96/EC on waste electrical and electronic equipment (WEEE).

This directive sets the framework for returning and recycling used equipment and is valid across the EU. When returning your used device, please use the return and collection systems available to you. Further information can be found at

<http://ts.fujitsu.com/recycling>.

Details regarding the return and recycling of devices and consumables within Europe can also be found in the "Returning used devices" manual, via your local Fujitsu branch or from our recycling center in Paderborn:

Fujitsu Technology Solutions
Recycling Center
D-33106 Paderborn

Tel. +49 5251 525 1410
Fax +49 5251 525 32 1410

5 Hardware installation



CAUTION!

- Follow the safety instructions in the chapter "[Important information](#)" on page 33.
- Do not expose the server to extreme environmental conditions (see "[Ambient conditions](#)" on page 27). Protect the server from dust, humidity and heat.
- Make sure that the server is acclimatized for the time indicated in this table before putting it into operation.

Temperature difference (°C)	Minimum acclimatization time (hours)
5	3
10	5
15	7
20	8
25	9
30	10

Table 1: Acclimatization time

In the [table "Acclimatization time"](#), the temperature difference refers to the difference between the operating environment temperature and the temperature to which the server was exposed previously (outside, transport or storage temperature).

5.1 Unpacking the server



CAUTION!

Follow the safety instructions in ["Introduction" on page 9](#).

The server must always be lifted or carried by at least two people.
(For the Japanese market, please refer to "安全上のご注意".)

Do not unpack the server until it is at its installation location.

- ▶ Transport the server to the place where you want to set it up.
- ▶ Unpack all individual parts.

Keep the original packaging in case you want to transport the server again
(applies only to global market).

- ▶ Check the delivery for any damage during transport.
- ▶ Check whether the items delivered match the details on the delivery note.

The product name and serial number of the product can be found on the ID card
(see section ["Front of server" on page 61](#)).

- ▶ Notify your supplier immediately should you discover that the items delivered do not correspond to the delivery note.

5.2 Installing/removing the server in/from the rack



CAUTION!

- Please observe the safety information and notes on rack mounting in chapter "Important information" on page 33 and section "Notes on installing the server in the rack" on page 43.
- At least two people are needed to install / remove the server in the rack. (For the Japanese market, please refer to "安全上のご注意".)
- Do not extend more than one unit out of the rack simultaneously even if the tilt protection is in place. If several units are simultaneously extended out of the rack, there is a risk that the rack could tip over.

Fujitsu rack systems

The rack systems from Fujitsu support the installation of PRIMERGY servers:

- PRIMECENTER rack
- PRIMECENTER M1 rack
- DataCenter rack
- 19-inch standard rack (for the Japanese market)
- 19-inch slimline rack (for the Japanese market)



For information on mounting the server in the rack please refer to the Mounting Instructions provided with the Rack Mounting Kit. Further information you find in the manual of your rack system.

For the Japanese market, please refer also to the "Rack system structure guide."



Online documentation for rack installation can be found on:

<http://manuals.ts.fujitsu.com/index.php?id=5406-5605-5606>
(for the global market)

http://jp.fujitsu.com/platform/server/primergy/manual/peri_rack.html
(for the Japanese market).

To accommodate the ventilation concept and ensure proper ventilation, any unused areas in the rack must be sealed using dummy covers.

The power is supplied via the multiple socket outlets fitted in the rack (for the global market).

Hardware installation

The main features of Fujitsu rack systems are as follows:

- rail systems that can be mounted without tools
- support systems having a linear alignment feature to ensure that they can be adjusted to different rack depths

Asymmetrical PRIMECENTER Rack and DataCenter Rack provide an enhanced cable management in the lateral rack area.

3rd party racks



Installation in most current rack systems from other manufacturers (3rd party racks) is also supported. For details please contact your sales representative.

5.3 Connecting devices to the server

The connectors for external devices are on the front and rear of the server. The additional connectors available on your server depend on the expansion cards installed. For further information refer to the "FUJITSU Server PRIMERGY RX2540 M2 Server Upgrade and Maintenance Manual".

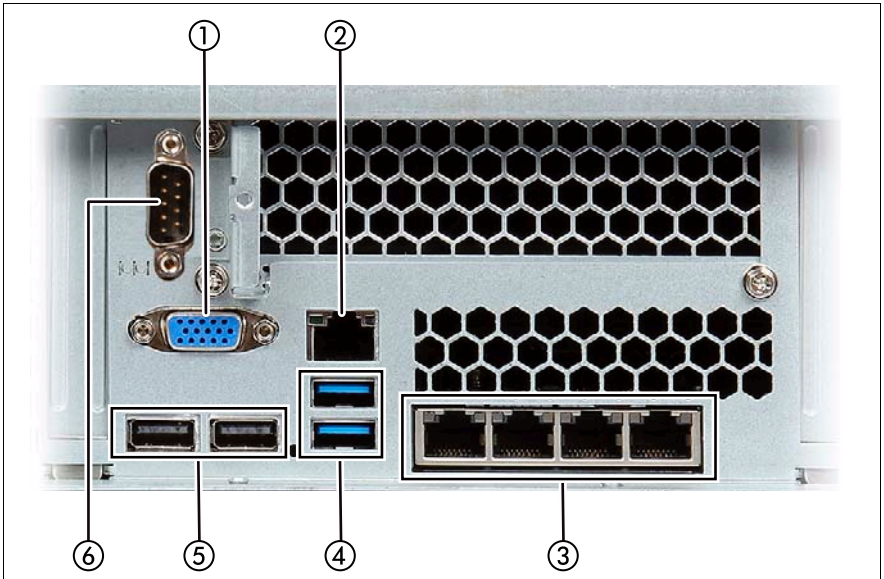

Figure 2: Connection panel on the rear

1	Video connector (blue)	4	2 USB connectors (USB 3.0)
2	Management LAN connector	5	2 USB connectors (USB 2.0)
3	Dynamic LoM (optional, different variants)*.	6	COM1 connector (optional)**

* The LAN connectors on the dynamic LoM modules are numbered in ascending order from right to left beginning with "0". The rightmost connector (LAN 0) is the shared LAN connector respectively.

** The serial interface COM1 can be used as the standard interface or for communication with iRMC.

Hardware installation



Some of the devices that can be connected may require the installation and setting up of special software (e.g. drivers) (see the documentation for the connected device).

- ▶ Connect the desired devices to the server.

Front side 3.5-inch HDD versions

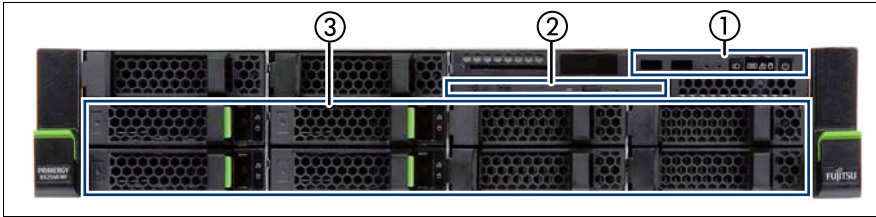

Figure 3: Front side 3.5-inch HDDs (up to 8 HDDs)

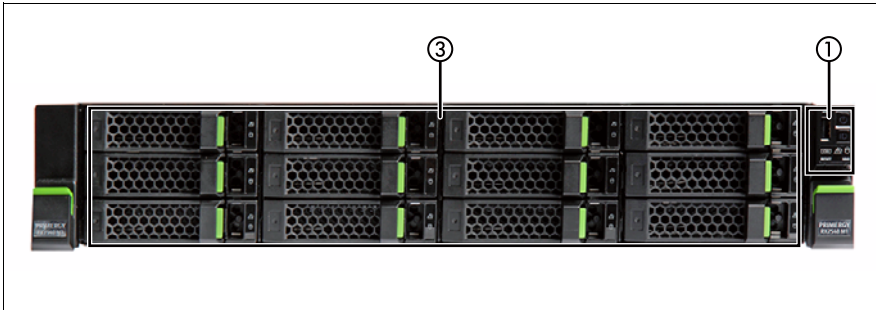

Figure 4: Front side 3.5-inch HDDs (up to 12 HDDs)

Pos.	Component
1	Front panel module
2	Optical disk drive
3	Space for hard disc drives (depending on the configuration)

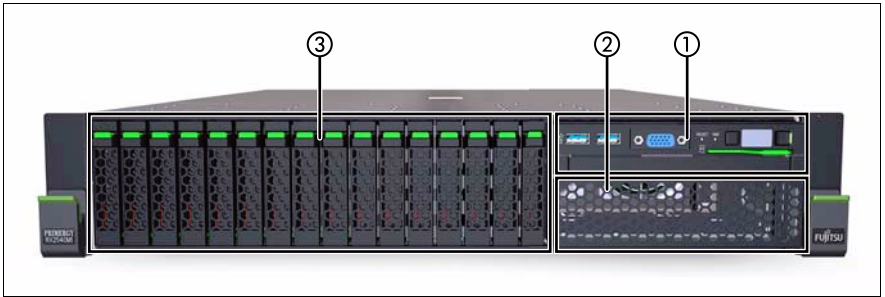

Figure 5: Front side 2.5-inch HDDs (up to 16 HDDs)

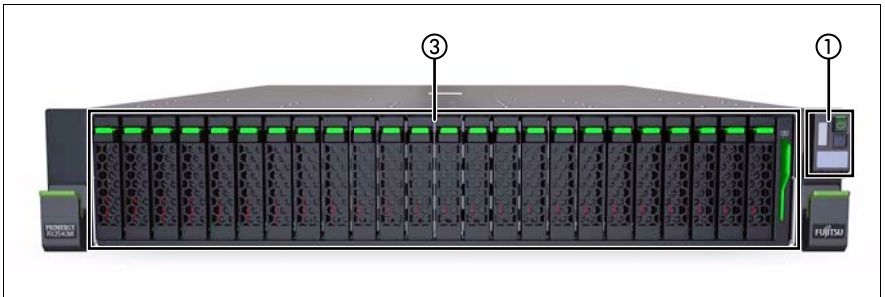

Figure 6: Front side 2.5-inch HDDs (up to 24 HDDs)

Pos.	Component
1	Front panel module
2	Space for LTO drive
3	Space for hard disc drives (depending on the configuration)

Hardware installation

Front side connectors 2.5-inch HDD versions

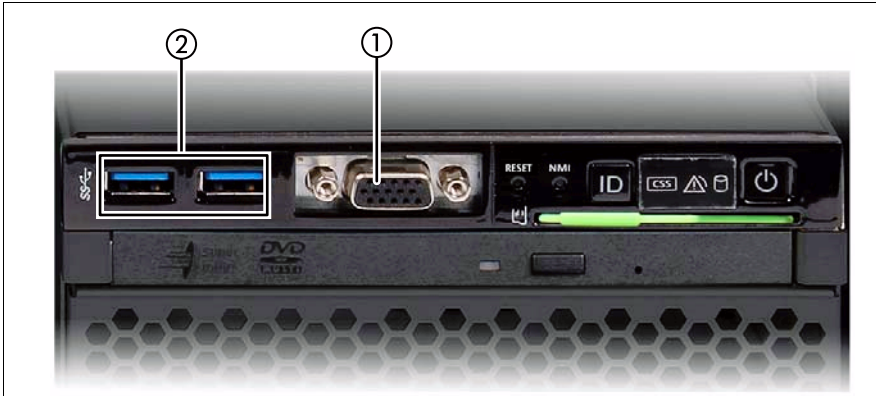

Figure 7: Front side connector 2.5-inch version

Front side connectors 3.5-inch HDD versions

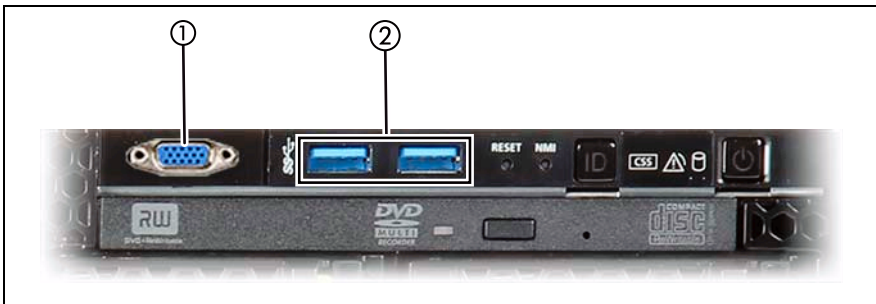

Figure 8: Front side connector 3.5-inch version

1	Front VGA	2	USB 3.0
---	-----------	---	---------



If components with large power requirements (e.g. external USB hard disk drives) are connected simultaneously, these USB connectors may be switched off.

Connecting the keyboard, mouse and monitor

- ▶ Connect the monitor, keyboard and mouse to the standard connectors of the server (see table and [figure 2 on page 51](#)).



If a separate graphics card is installed in a slot, the graphic controller on the system board is automatically deactivated. The corresponding video connector (VGA) can not be used. Plug the data cable of the monitor into the video connector of the graphics card.

- ▶ Connect the power cable of the monitor to the mains socket strip of the rack.



CAUTION!

The rated current for the monitor is indicated on the technical data label on the monitor or in the operating manual for the monitor.

5.4 Connecting the server to the power source

In its basic configuration level the server has a hot-plug power supply unit.

A second hot-plug power supply unit can be added to ensure a redundant power supply. If one power supply unit is defective, the other then guarantees unimpaired operation. Each hot-plug power supply unit can be replaced during operation (see the "FUJITSU Server PRIMERGY RX2540 M2 Server Upgrade and Maintenance Manual").



CAUTION!

The server is automatically set to a mains voltage in the range from 100 V - 240 V (Platinum) or 200 V - 240 V (Titanium). You may only operate the server if its rated voltage range corresponds to the local mains voltage.

5.4.1 Connecting the server to the mains

- ▶ Connect the power cord with the insulated connector to the power supply unit of the server, and plug the power plug into a grounded outlet on the mains socket strip on the rack (see Technical Manual of the rack).



A phase redundancy in the power supply of the server can be set up if two hot-plug power supply units are installed.

In this case, each of the power supply units is either connected to two different phases or to two separate circuits of the internal power supply network.

5.4.2 Using the cable clamp

You can secure the power cords in a cable clamp to ensure that the insulated connectors cannot be disconnected from the server accidentally.

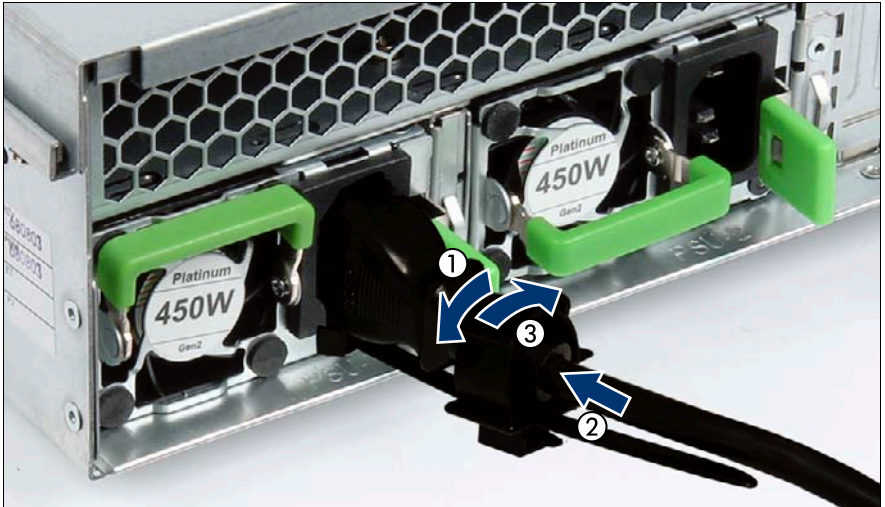

Figure 9: Cable clamp (example AC power supply unit)

- ▶ Pull the cable clamp up (1).
- ▶ Thread the power cord through the cable clamp (2).
- ▶ Press the cable clamp down until it engages to secure the cable (3).

5.5 Notes on connecting/disconnecting cables



CAUTION!

Always read the documentation supplied with the device you wish to connect.

Never connect, or disconnect cables during a thunderstorm.

Never pull on a cable when disconnecting it. Always take hold of the cable by the plug.

Follow the sequence described below to connect or disconnect external devices to or from the server:

Be sure to wait for 10 seconds or more after shutdown before turning the server on.

Connecting cables

- ▶ Turn off all power and equipment switches.
- ▶ Disconnect all power plugs from the properly grounded power outlets.
- ▶ Connect all cables to the server and peripherals.
- ▶ Plug all data communication cables into the utility sockets.
- ▶ Plug all power cords into the properly grounded power outlets.

Disconnecting cables

- ▶ Turn off all power and equipment switches.
- ▶ Disconnect all power plugs from the properly grounded power outlets.
- ▶ Unplug all data communication cables from the utility sockets.
- ▶ Disconnect the relevant cables from the server and all the peripherals.



For connecting or disconnecting LAN cables, the server does not need to be powered off. To avoid loss of data teaming function has to be enabled.

Information for ensuring electromagnetic compatibility

All data and signal cables must have sufficient shielding. The use of cable type S/FTP Cat5 or higher is recommended.

Use of unshielded or badly shielded cables may lead to increased emission of interference and/or reduced fault-tolerance of the device.

6 Starting up and operation



CAUTION!

Please note the safety instructions in chapter ["Important information" on page 33](#)

6.1 Controls and indicators

6.1.1 Front of server

3.5-inch HDD versions

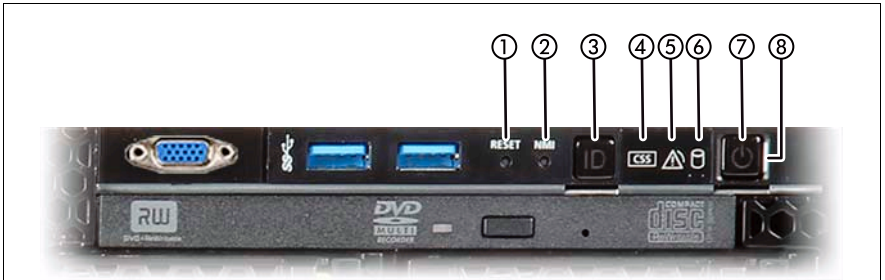

Figure 10: Indicators on the front panel module 3.5-inch HDD

2.5-inch HDD versions

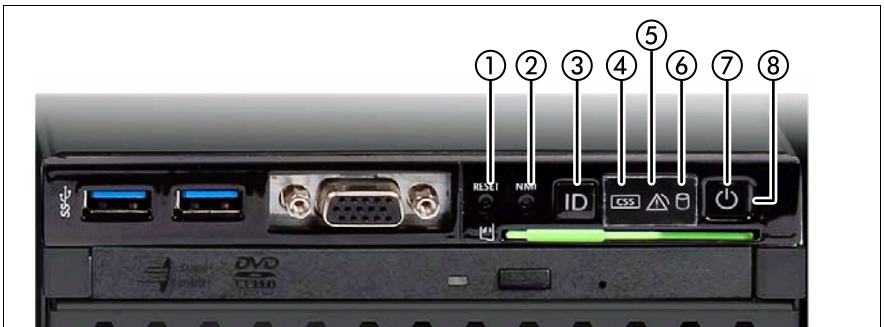

Figure 11: Indicators on the front panel module 2.5-inch HDD

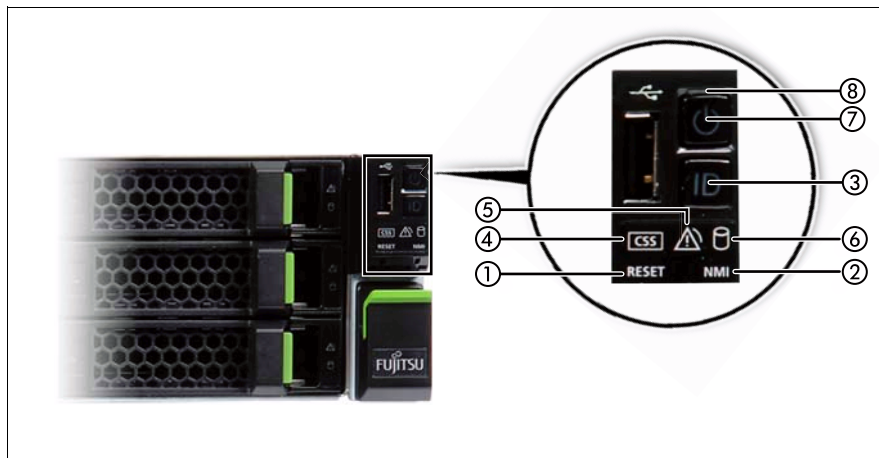





Figure 12: Indicators on the front panel on QRL

1	Reset button	5	Global Error indicator
2	NMI button	6	HDD activity indicator
3	ID button / ID indicator	7	On/Off button / Power-on indicator
4	CSS indicator	8	AC connected indicator

6.1.1.1 Control elements

Pos.	Button	Function
1	Reset button	<p>This button is used to reboot the system. It can be pressed using the end of a paper clip.</p> <p> CAUTION! Risk of data loss!</p>
2	NMI button	<p>This button is used to troubleshoot software and device driver errors. It can be pressed using the end of a paper clip.</p> <p> CAUTION! Use this button only if directed to do so by qualified certified maintenance personnel!</p>
3	ID button	<p>This button highlights the ID indicator on the front and I/O panels for easy server identification.</p>
7	On / Off button	<p> If the system is running an ACPI-compliant operating system, the pressing the On / Off button will performs a graceful shutdown.</p>

6.1.1.2 Indicators on the control panel

Pos.	Indicator	Status	Description
3	ID indicator	blue on	server has been highlighted using ServerView Operations Manager, iRMC web frontend or the ID button on the front panel for easy identification
		blue flashing	server has been highlighted using iRMC (AVR) when local VGA off for easy identification
4	CSS indicator	off	no critical event (CSS component)
		orange on	prefailure detected (CSS component)
		orange flashing	CSS component failure
5	Global error indicator	off	no critical event (non CSS component)
		orange on	prefailure detected (non CSS component)
		orange flashing	non CSS component failure
6	HDD / SSD activity indicator	green flashing	data access in progress
7	Power-on indicator	off	is off in the following case: <ul style="list-style-type: none"> – the system is in power-off mode but connected to the mains (AC connected)
		green on	is on in the following cases: <ul style="list-style-type: none"> – the system has been switched on and is in power-on delay – the system is powered on and in normal operation (S0)
		flashes slowly (1/2 Hz)	iRMC S4 is not ready

Pos.	Indicator	Status	Description
8	AC connected indicator	green on	<p>is on in the following cases:</p> <ul style="list-style-type: none"> – the system is in power-off mode but connected to the mains (AC connected) – the system has been switched on and is in power-on delay <p> After connecting the server to the mains it takes about 60 seconds until the server enters the standby mode.</p>
		off	<p>is off in the following cases:</p> <ul style="list-style-type: none"> – the system is not connected to the mains – the system is powered on and in normal operation (S0)

iRMC-related status signals

ID indicator	Global error indicator	Description
blue flashing	off	A remote connection has been established. Local VGA output has been disabled during the remote session.
blue flashing	orange flashing	An emergency flash of the iRMC firmware is in progress.

Starting up and operation

6.1.1.3 ID card

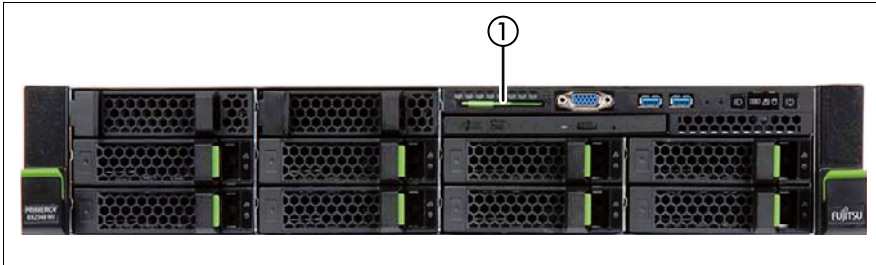

Figure 13: ID card - 3.5-inch variant



12x3.5-inch version: There is an identification sticker placed on the server top. (For the Japanese market, there is an identification sticker placed above the quick release lever.)

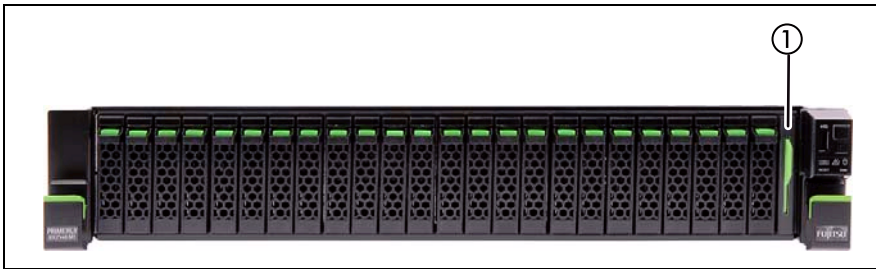

Figure 14: ID card - 2.5-inch variant



Figure 15: ID card - 2.5-inch variant

You can pull out the ID card (1) as far as it will go and push it back again.

The ID card contains various system information, such as the product name, serial number, order number, MAC addresses and DNS name (in the Japanese market, only the product name and the serial number).

6.1.2 Indicators on the drives

Optical drive activity indicator

Lights up green when the storage medium is being accessed.

Hard disk drive indicators



Figure 16: Indicators on the 3.5 inch HDD modules



Figure 17: Indicators on the 2.5 inch HDD modules

1	LED orange	<p>HDD FAULT (orange) (in conjunction with a RAID controller)</p> <ul style="list-style-type: none"> – Does not light: no HDD error – Lights up: HDD Faulty or Rebuild Stopped (drive defective/needs replacing, a rebuild process was stopped or the HDD module is not correctly inserted) – Slow flashing: HDD Rebuild (the data is being restored after changing a drive) – Fast flashing: HDD Identify
2	LED green	<p>HDD BUSY</p> <ul style="list-style-type: none"> – Lights up: HDD in active phase – Does not light: HDD inactive (drive inactive)

6.1.3 Rear of server

Global Error, ID and CSS indicators

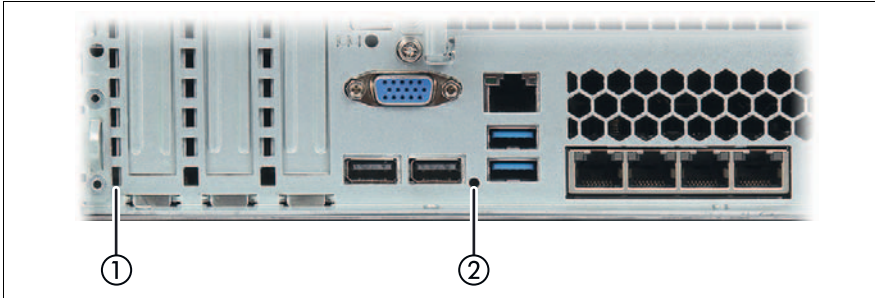

Figure 18: Global Error and CSS indicators

1	<p>Global Error indicator (orange) on the system board, visible through the chassis perforation.</p> <ul style="list-style-type: none">– Lights up orange if a prefailure event has been detected that requires (precautionary) service intervention.– Flashes orange if an error was detected that requires service intervention.– Does not light up if there is no critical event. <p>If the event is still acute after a power cycle, the indicator is activated after the restart.</p> <p>The indicator also lights up in standby mode.</p> <p>You can find more details on the indicated errors in the System Event Log (SEL), in the ServerView Operations Manager or via the iRMC S4's Web interface.</p> <p>ID indicator (blue) on the system board, visible through the chassis perforation.</p> <p>Lights up blue when the system has been selected by pressing the ID button. To deactivate, press the button again.</p> <p>The ID indicator can also be activated via the ServerView Operations Manager and the iRMC S4 Web interface and its status reported to the ServerView Operations Manager and to the iRMC S4.</p>
---	---

2	<p>CSS indicator (orange)</p> <ul style="list-style-type: none">– Lights up orange if a prefailure event was detected for a CSS component that you can fix yourself (for reasons of precaution) with the CSS concept.– Flashes orange if an error was detected that you can fix yourself with the CSS concept.– Does not light up when the system is OK. <p>If the event is still acute after a power cycle, the indicator is activated after the restart.</p> <p>The indicator also lights up in standby mode.</p> <p>For more information on the CSS concept, see "Customer Self Service (CSS)" on page 13.</p>
---	--

LAN indicators

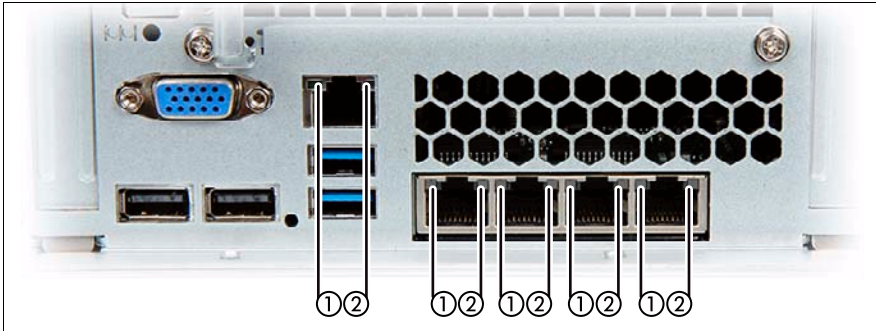

Figure 19: Indicators on the connection panel: LAN indicators (example LoM: PLAN EM 4x1GB T)

1	LAN link/transfer	Steady green signal when a LAN connection exists. Remains dark when no LAN connection exists. Flashes green when LAN transfer takes place.
2	LAN speed	Steady yellow signal in the event of a LAN transfer rate of 1 Gbit/s Steady green signal in the event of a LAN transfer rate of 100 Mbit/s. Remains dark in the event of a LAN transfer rate of 10 Mbit/s.

Indicators on the hot-plug power supply unit

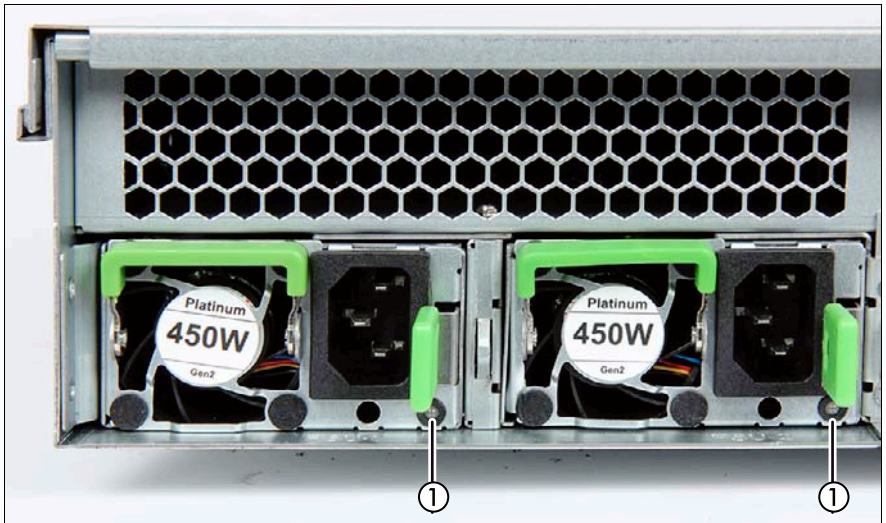

Figure 20: Indicator on hot-plug power supply unit

1	<p>Indicator on hot-plug power supply unit (two colors)</p> <p>Flashes green when the server is switched off, but AC voltage is present (standby mode).</p> <p>Lights up green when the server is switched on and functioning properly.</p> <p>Flashes orange in case of overload, but the power supply unit is still running.</p> <p>Lights up orange in case of PSU failure, overvoltage / undervoltage, overtemperature, fan fail.</p>
---	---

6.2 Switching the server on and off



CAUTION!

- If nothing appears on the screen but flickering stripes after switching on the server, switch the server off immediately (see chapter "[Troubleshooting and tips](#)" on page 83).
- The On/Off button does not disconnect the server from the mains voltage. To completely disconnect it from the mains voltage, remove the power plug(s) from all PSU inlet connectors.
- Do not move, strike, or shake the server when it is turned on. This can damage the hard disk in the server and cause data loss.
- Turn the server on when the temperature is within its operating environment range (10–35°C). For details on the operating environment, refer to "Safety Precautions". When operating the device outside of this operating environment, the server may operate improperly and data loss may occur. Furthermore, Fujitsu cannot be held responsible for any related damage, malfunction, or loss of data, etc.
- Be sure to wait for 10 seconds or more after shutdown before turning on the server again (power-on delay time).
- After connecting all power cords, wait at least 10 seconds before pressing the On/Off button.

Switching the server on

The AC connected indicator lights up green when the server is off but connected to the mains.

The controls and indicators are shown in [figure 10 on page 61](#), [figure 11 on page 61](#) and [figure 12 on page 62](#).



After connecting the server to the mains, it takes about 60 seconds until power-on becomes possible.

– Starting up for the first time:

For the Japanese market, please refer to "はじめにお読みください".

- ▶ Press the On/Off button.

- ▶ Insert ServerView Suite DVD in the DVD drive.
 - ▶ Follow the on-screen instructions (see also section ["Configuring the server and installing the operating system with the ServerView Installation Manager" on page 77](#) or section ["Configuring the server and installing the operating system without the ServerView Installation Manager" on page 78](#)).
- **Operating system already installed:**
- ▶ Press the On/Off button.
- The server is switched on, performs a self test and starts loading the operating system.



In the case of configurations with a large memory size, the boot process may be prolonged and the screen may remain dark for several minutes.

Switching the server off

The Power-on indicator (see [figure 10 on page 61](#), [figure 11 on page 61](#) and [figure 12 on page 62](#)) lights up green.

- ▶ Shut down the operating system properly.

The server is switched off automatically. The AC connected indicator lights up green.



If the operating system does not switch off the server automatically, press the On/Off button for at least four seconds and/or send a corresponding control signal for power button override.

Other On/Off options

Besides the On/Off button, the server can be switched ON and OFF in the following ways:

– **Timer-controlled switch-on/off**

Using the ServerView Operations Manager or iRMC S4, you can configure that the server is switched on/off controlled by an internal timer.

– **Ring indicator**

The server is switched on by an internal or external modem.

– Wake up On LAN (WOL)

The server is switched on by a command via the LAN (Magic Packet™).

– After power failure

The server automatically reboots following a power failure (depending on the settings in the BIOS or in iRMC S4).

– Power button override

The system can be switched off (hard power off) by keeping the On/Off button (approximately 4 - 5 seconds).



CAUTION!

There is a risk that data may be lost.

– iRMC S4

iRMC S4 offers various options for switching the server on and off, e.g. via the *Power On Off* page of the iRMC S4 Web interface.



CAUTION when turning the power off (Windows Server 2012 or Windows Server 2008)!

The operation of the power switch can be specified as "Do Nothing", "Stand by", "Hibernate", and "Shutdown" depending on the OS settings. The default is "Shutdown".

On this server, functions corresponding to "Stand by" and "Hibernate" are supported as BIOS and hardware functions. However, some drivers and software installed in the server do not support these functions. For this reason, functions corresponding to "Stand by" and "Hibernate" are unavailable on this server. When the operating mode is set to "Stand by" or "Hibernate", the system may operate improperly or hard disk data may be corrupted.

For details about operating mode settings, refer to the manual supplied with the OS.



6.3 Configuring the server

This section contains information about configuring the server and installing the operating system.

-  Make sure that the power saving functions are disabled in the *Power* menu of the BIOS Setup during operation.

6.3.1 Configuring the onboard SATA controller

A SATA controller is integrated on the system board. You can configure the onboard controller either before or during installation with the ServerView Installation Manager. Using the ServerView Installation Manager is recommended.

-  The controller has its own configuration utility. For further information, refer to the “Embedded MegaRAID Software User’s Guide” (on the Fujitsu manuals server under *x86 Servers - Expansion Cards - Storage Adapters - LSI SAS / SCSI RAID Controllers*).
-  Descriptions of operating systems not covered in the controller manual are provided in the corresponding readme under:
<http://www.fujitsu.com/global/services/computing/server/ia/driver/index.html>
(for the global market).
<http://www.fmworld.net/cgi-bin/drviasearch/drviaindex.cgi>
(for the Japanese market).
-  In the system BIOS the onboard SATA controller can be configured as "IDE", "AHCI" or "non-RAID".

6.3.2 Configuring the SAS/SATA RAID controller (PCIe expansion card)

The server has a SAS/SATA RAID controller with "MegaRAID functionality". You can configure the SAS/SATA RAID controller either before or during installation with the ServerView Installation Manager. Using the ServerView Installation Manager is recommended.

i A separate utility is available to the controller for MegaRAID configuration. For further information, refer to the "SAS Software User's Guide" (on the Fujitsu manuals server under *x86 Servers - Expansion Cards - Storage Adapters - LSI Configuration Software*).

Further information on modular RAID controllers is provided in the "Modular RAID Controller Installation Guide" (on the Fujitsu manuals server under *x86 Servers - Expansion Cards - Storage Adapters - LSI SAS / SCSI RAID Controllers*).

i Descriptions of operating systems not covered in the controller manual are provided in the corresponding readme under:

<http://www.fujitsu.com/global/services/computing/server/ia/driver/index.html>
(for the global market).

<http://jp.fujitsu.com/platform/server/primergy/downloads/>
(for the Japanese market).

6.3.3 Configuring the server and installing the operating system with the ServerView Installation Manager

Using the ServerView Installation Manager on the ServerView Suite DVD provided, you can conveniently configure the server and install the operating system. This includes configuring the server-specific settings using the ServerView Configuration Manager and configuring the RAID controller using the **ServerView RAID Manager**.

Advantages of the ServerView Installation Manager

- Wizard assisted configuration of your server hardware and disk arrays
- Wizard assisted installation of all leading server operating systems
- Wizard-assisted creation of configuration files for unattended installation of several PRIMERGY servers with identical hardware configurations.
- Installation of drivers and additional software.



The software that can be installed depends on your server's hardware configuration. This configuration is detected automatically.



Descriptions of operating systems not covered in the RAID controller manual are provided in the corresponding readme files under:

<http://www.fujitsu.com/global/services/computing/server/ia/driver/index.html>
(for the global market).

<http://jp.fujitsu.com/platform/server/primergy/downloads/>
(for the Japanese market).

To find out how to operate the ServerView Installation Manager and for further information, refer to the associated manual.

If you are using the ServerView Installation Manager, you can skip the following section on how to configure the server and install the operating system. Continue from section "[Cleaning the server](#)" on page 79.

6.3.4 Configuring the server and installing the operating system without the ServerView Installation Manager

Configuring the onboard SATA RAID controller with "Integrated Mirroring Enhanced"

Configure the controller as described in section "[Configuring the onboard SATA controller](#)" on page 75.

Configuring the SAS/SATA RAID controller (PCIe expansion card)

Configure the controller as described in section "[Configuring the SAS/SATA RAID controller \(PCIe expansion card\)](#)" on page 76.

Installing the operating system

- ▶ Insert the CD/DVD for the operating system you want to install.
- ▶ Reboot the server.
- ▶ Follow the instructions on screen and in the manual for the operating system.

6.4 Cleaning the server



CAUTION!

Switch off the server and disconnect the power plugs from the properly grounded power outlets.

Do not clean any interior parts yourself; leave this job to a service technician.

Do not use any cleaning agents that contain abrasives or may corrode plastic.

Ensure that no liquid enters the system. Ensure that the ventilation areas of the server and the monitor are clear.

Do not use any cleaning sprays (including flammable types). It may cause a device failure or a fire.

Clean the keyboard and the mouse with a disinfecting cloth.

Wipe the server and monitor casing with a dry cloth. If particularly dirty, use a cloth that has been moistened in a mild domestic detergent and then carefully wrung out.

7 Property and data protection

The rack model is protected against unauthorized access by a lockable rack door.

To protect your system and data internally against unauthorized access, you can use the BIOS Setup security functions.

7.1 BIOS Setup security functions

The *Security* menu in BIOS Setup offers various options for protecting your data from unauthorized access. By combining these options, you can also achieve optimum protection for your system.



A detailed description of the *Security* menu and how to assign passwords can be found in the "D3289 BIOS Setup Utility for FUJITSU Server PRIMERGY RX2540 M2 Reference Manual".

8 Troubleshooting and tips



CAUTION!

Follow the safety instructions in the "Safety notes and regulations" manual or "安全上のご注意" and in chapter ["Important information" on page 33](#).

If a fault occurs, attempt to resolve it using the measures described:

- in this chapter,
- in the documentation for the connected devices,
- in the help systems of the software used.

If you fail to correct the problem, proceed as follows:

- ▶ Make a list of the steps performed and the circumstances that led to the fault. Also make a list of any error messages that were displayed.
- ▶ Switch off the server.
- ▶ Contact our customer service team.

8.1 Power-on indicator remains unlit

The power-on indicator remains dark after you switch on your device.

Power cable incorrectly connected

- ▶ Make sure that the power cable(s) is/are correctly connected to the server and the grounded power outlet(s).

Power supply overloaded

- ▶ Disconnect the server power plug(s) from the grounded power outlet(s).
- ▶ Wait a few minutes before you plug it/them into the grounded power outlet(s) again.
- ▶ Switch on your server.

8.2 Server switches itself off

Server Management has detected an error

- ▶ Check the error list of System Event Log in ServerView Operations Manager or in the iRMC web interface, and attempt to eliminate the error.

8.3 Screen remains blank

Monitor is switched off

- ▶ Switch on your monitor.

Screen has gone blank

- ▶ Press any key on the keyboard.
or
- ▶ Deactivate screen saver. Enter the appropriate password.

Brightness control is set to dark

- ▶ Set the brightness control on the monitor to light. For detailed information, refer to the operating manual supplied with your monitor.

Power cable or monitor cable not connected

- ▶ Switch off the monitor and the server.
- ▶ Check whether the power cable is properly connected to the monitor and to the grounded power outlet.
- ▶ Check whether the monitor cable is properly connected to the server and monitor (if it is plugged in with a connector). If a separate graphics card is installed in the server, then the monitor cable must be connected to the graphics card.
- ▶ Switch on the monitor and the server.

8.4 Flickering stripes on monitor screen



CAUTION!

Switch off the server immediately. Risk of damaging the server.

Monitor does not support the set horizontal frequency

- ▶ Find out which horizontal frequency your monitor screen supports. You will find the horizontal frequency (also known as line frequency or horizontal deflection frequency) in the documentation for your monitor.
- ▶ Refer to the documentation for your operating system or the software for the screen controller for details of how to set the correct horizontal frequency for your monitor, and follow the procedure accordingly.

8.5 No screen display or display drifts

The wrong horizontal frequency or resolution has been selected for the monitor or for the application program.

- ▶ Find out which horizontal frequency your monitor screen supports. You will find the horizontal frequency (also known as line frequency or horizontal deflection frequency) in the documentation for your monitor.
- ▶ Refer to the documentation for your operating system or the software for the screen controller for details of how to set the correct horizontal frequency for your monitor, and follow the procedure accordingly.

8.6 Incorrect date and time

- ▶ Set the date and time in the operating system or in the BIOS Setup under the Main menu, using System Date and System Time respectively.



Note that the operating system may affect the system time. For example, the operating system time may deviate from the system time under Linux, and would overwrite the system time in the default setting on shutdown.

If the date and time are still wrong after the server has been switched off and back on again, replace the lithium battery (for a description refer to the "FUJITSU Server PRIMERGY RX2540 M2 Upgrade and Maintenance Manual") or contact our customer service team.

8.7 System will not boot

The system will not boot after installing a new hard disk drive.

SAS configuration incorrect

- ▶ Check the settings for the hard disk drives (SAS Device Configuration) and the additional settings in the SAS configuration menu.

8.8 Hard disk drive error messages at system boot

Various hard disk drive error messages may occur when the system is rebooted. These error messages are caused by modifications in the selected RAID configuration.

RAID controller configuration incorrect

- ▶ Check and correct the settings for the drives using the RAID controller configuration program.



Further information is provided in the "Integrated RAID for SAS User's Guide" (on the Fujitsu manuals server under *x86 Servers - Expansion Cards - Storage Adapters - LSI RAID / SCSI Controllers*) or in the "Modular RAID Controller Installation Guide" (on the Fujitsu manuals server under *x86 Servers - Expansion Cards - Storage Adapters - LSI RAID / SCSI Controllers*).

For more information on configuring the controller, see section "[Configuring the server](#)" on page 75.

8.9 Added drive reported as defective

RAID controller is not configured for this drive

The drive was probably installed when the system was switched off.

- ▶ Reconfigure the RAID controller for the drive using the corresponding utility. Information is provided in the documentation for the RAID controller.

or

- ▶ Remove and reinstall the drive while the system is switched ON.

If the drive continues to be shown as defective, then replace it.

8.10 Error message on screen

The meaning of the error message is explained in the documentation for the relevant components and programs on the Fujitsu manuals server.

8.11 Expansion cards or onboard devices not recognized

When an expansion card is added, other expansion cards or onboard devices might not be recognized.

- ▶ Reinstall the drivers for the expansion cards or onboard devices that are not recognized.

8.12 Temperature warning

A temperature warning is output to the hardware event log and OS event log, or ServerView issues a notification of a temperature warning such as by a popup message

The above log is output or the above notification is issued by ServerView when the ambient temperature exceeds the upper limit of the temperature boundaries. The upper limit is 35°C for standard server and 40°C or 45°C with Fujitsu Advanced Thermal Design.

- ▶ Although continued use within the temperature boundaries poses no problems within itself, reconsider the surrounding environment conditions if this log is output or if ServerView issues this notification.

8.13 No effect of keyboard or mouse

Typing the keyboard does not display any characters, or the mouse cursor does not move.

- ▶ Check to see whether the keyboard and mouse are connected properly. If they are not connected or you replaced them yourself, then connect the cables to the server.

8.14 Optical drive cannot read data

- ▶ Check to see whether the CD/DVD/BD is inserted properly. If the CD/DVD/BD is not inserted, correctly insert the disk so that the label is facing up.
- ▶ Check to see whether the CD/DVD/BD is not dirty. If the CD/DVD/BD is dirty, wipe it in a radial way with a soft, dry cloth.
- ▶ Check to see whether the CD/DVD/BD is not scratched or bent. If scratched or damaged, replace the CD/DVD/BD.